

# Integrated Display Industrial Computers

Catalog Numbers 6181P, 6189V-6181TRAY, 6189V-6181HDD100GB, 6189V-6181SSD32GB, 6189V-6181SSD64GB, 6189V-BOOKBRKT, 6189V-DPDVI, 6189V-DPVGA, 6189V-PCIR, 6189V-EXTPCI2, 6189V-PSU6181AC, 6189V-PSU6181DC, 6189V-8GSODDR3, 6189V-16GSODDR3, 6189V-ODD, 6189V-ACCESSBOX6181



## Important User Information

Read this document and the documents listed in the additional resources section about installation, configuration, and operation of this equipment before you install, configure, operate, or maintain this product. Users are required to familiarize themselves with installation and wiring instructions in addition to requirements of all applicable codes, laws, and standards.

Activities including installation, adjustments, putting into service, use, assembly, disassembly, and maintenance are required to be carried out by suitably trained personnel in accordance with applicable code of practice.

If this equipment is used in a manner not specified by the manufacturer, the protection provided by the equipment may be impaired.

In no event will Rockwell Automation, Inc. be responsible or liable for indirect or consequential damages resulting from the use or application of this equipment.

The examples and diagrams in this manual are included solely for illustrative purposes. Because of the many variables and requirements associated with any particular installation, Rockwell Automation, Inc. cannot assume responsibility or liability for actual use based on the examples and diagrams.

No patent liability is assumed by Rockwell Automation, Inc. with respect to use of information, circuits, equipment, or software described in this manual.

Reproduction of the contents of this manual, in whole or in part, without written permission of Rockwell Automation, Inc., is prohibited

Throughout this manual, when necessary, we use notes to make you aware of safety considerations.



**WARNING:** Identifies information about practices or circumstances that can cause an explosion in a hazardous environment, which may lead to personal injury or death, property damage, or economic loss.



**ATTENTION:** Identifies information about practices or circumstances that can lead to personal injury or death, property damage, or economic loss. Attentions help you identify a hazard, avoid a hazard, and recognize the consequence.

---

**IMPORTANT**

Identifies information that is critical for successful application and understanding of the product.

---

Labels may also be on or inside the equipment to provide specific precautions.



**SHOCK HAZARD:** Labels may be on or inside the equipment, for example, a drive or motor, to alert people that dangerous voltage may be present.



**BURN HAZARD:** Labels may be on or inside the equipment, for example, a drive or motor, to alert people that surfaces may reach dangerous temperatures.



**ARC FLASH HAZARD:** Labels may be on or inside the equipment, for example, a motor control center, to alert people to potential Arc Flash. Arc Flash will cause severe injury or death. Wear proper Personal Protective Equipment (PPE). Follow ALL Regulatory requirements for safe work practices and for Personal Protective Equipment (PPE).

---

|                             |  |    |
|-----------------------------|--|----|
|                             | <b>Preface</b>                                     |    |
|                             | Summary of Changes.....                            | 7  |
|                             | Abbreviations.....                                 | 8  |
|                             | Additional Resources.....                          | 8  |
|                             | <b>Chapter 1</b>                                   |    |
| <b>Features</b>             | Operating Systems .....                            | 9  |
|                             | Computer Options.....                              | 10 |
|                             | Hardware Features .....                            | 12 |
|                             | External Components and I/O .....                  | 12 |
|                             | Internal Components.....                           | 14 |
|                             | System Features.....                               | 15 |
|                             | Multi-touch Touchscreens .....                     | 15 |
|                             | Status Indicators and UIB.....                     | 16 |
|                             | Hardware Monitor and Watchdog Timer Utilities..... | 17 |
|                             | Intel Active Management Technology (AMT) 9.0 ..... | 17 |
|                             | Intel Rapid Start Technology.....                  | 18 |
|                             | <b>Chapter 2</b>                                   |    |
| <b>Install the Computer</b> | Before You Begin .....                             | 19 |
|                             | Parts List .....                                   | 19 |
|                             | Installation Precautions.....                      | 20 |
|                             | Environment and Enclosure Information.....         | 20 |
|                             | European Union Directive .....                     | 20 |
|                             | Installation Guidelines .....                      | 21 |
|                             | Mounting Clearance Requirements.....               | 22 |
|                             | Computer Dimensions .....                          | 23 |
|                             | Tools for Computer Installation.....               | 27 |
|                             | Install the Computer .....                         | 27 |
|                             | Panel Mounting Guidelines .....                    | 27 |
|                             | Panel Cutout Dimensions .....                      | 28 |
|                             | Mount the Display Computer in a Panel .....        | 29 |
|                             | Mount the Non-display Computer .....               | 31 |
|                             | Connect Peripherals .....                          | 32 |
|                             | Connect Power .....                                | 33 |
|                             | Connect AC Power.....                              | 33 |
|                             | Connect DC Power .....                             | 34 |
|                             | Functional Ground Screw .....                      | 35 |
|                             | AC Power Models.....                               | 35 |
|                             | DC Power Models.....                               | 35 |
|                             | Connect to a Network .....                         | 36 |

|                                |  |    |
|--------------------------------|--|----|
| <b>Operate the Computer</b>    | <b>Chapter 3</b>                             |    |
|                                | Operating Guidelines.....                    | 37 |
|                                | Touchscreen Precautions.....                 | 38 |
|                                | Start the Computer.....                      | 38 |
|                                | Restart the Computer.....                    | 39 |
|                                | Shut Down the Computer.....                  | 39 |
|                                | Adjust the Display Brightness.....           | 40 |
| <b>Replace Components</b>      | <b>Chapter 4</b>                             |    |
|                                | Accessories and Replacement Parts.....       | 41 |
|                                | Voltage Precautions.....                     | 41 |
|                                | Electrostatic Discharge Precautions.....     | 42 |
|                                | Pre-configuration.....                       | 42 |
|                                | Post-configuration.....                      | 43 |
|                                | Required Tools.....                          | 43 |
|                                | Remove the Cover.....                        | 43 |
|                                | Reinstall the Cover.....                     | 44 |
|                                | CompactFlash Card.....                       | 44 |
|                                | Drive Precautions.....                       | 45 |
|                                | Replace a Drive.....                         | 46 |
|                                | Replace or Add Memory Modules.....           | 47 |
|                                | Memory Configuration Guidelines.....         | 47 |
|                                | Replace or Add a Memory Module.....          | 48 |
|                                | Replace the RTC Battery.....                 | 49 |
|                                | Replace the Power Supply Unit.....           | 51 |
| <b>Set Up the UEFI Utility</b> | <b>Chapter 5</b>                             |    |
|                                | Set-up Utility Overview.....                 | 55 |
|                                | Access the Set-up Utility.....               | 56 |
|                                | Set-up Screen Overview.....                  | 56 |
|                                | Firmware Update.....                         | 57 |
|                                | Firmware Configuration.....                  | 58 |
|                                | Common Buttons at the Bottom of Screens..... | 58 |
|                                | Main.....                                    | 59 |
|                                | Advanced.....                                | 60 |
|                                | Chipset.....                                 | 72 |
|                                | Boot.....                                    | 75 |
|                                | Security.....                                | 76 |
|                                | Save & Exit.....                             | 77 |
|                                | Diagnostics.....                             | 78 |
|                                | AMI Rescue.....                              | 80 |
|                                | Make a Backup.....                           | 82 |
|                                | Restore from an Image.....                   | 83 |
|                                | Hardware History.....                        | 84 |
|                                | Exit.....                                    | 85 |

|                                |   |     |
|--------------------------------|---|-----|
|                                | <b>Chapter 6</b>                          |     |
| <b>Troubleshoot the System</b> | Hardware Monitoring .....                 | 87  |
|                                | Troubleshooting .....                     | 88  |
|                                | Diagnostics .....                         | 89  |
|                                | Load the System Defaults .....            | 90  |
|                                | Clear the UEFI .....                      | 91  |
|                                | Ship or Transport the Computer .....      | 91  |
|                                | Dispose of the Computer .....             | 92  |
|                                | <b>Chapter 7</b>                          |     |
| <b>Use a Touch Screen</b>      | .....                                     | 93  |
|                                | Touch Screen Technology .....             | 93  |
|                                | Driver Software .....                     | 93  |
|                                | PCAP Touch Screen Technology.....         | 94  |
|                                | Resistive Technology .....                | 94  |
|                                | Calibrate the Resistive Touchscreen ..... | 95  |
|                                | <b>Chapter 8</b>                          |     |
| <b>Clean the Computer</b>      | Clean the Computer .....                  | 97  |
|                                | Clean the Integrated Display .....        | 97  |
|                                | Clean the Fan (Intel Core i7 models)..... | 98  |
|                                | Clean the Heat Sink and Vent Holes.....   | 98  |
|                                | Remove Paint and Grease from Bezel .....  | 98  |
|                                | <b>Appendix A</b>                         |     |
| <b>Install Accessories</b>     | Available Accessories .....               | 99  |
|                                | Pre-installation Checklist .....          | 99  |
|                                | Install an Add-in Card.....               | 100 |
|                                | PCI/PCIe Riser Board Options .....        | 102 |
|                                | Install Additional Memory.....            | 104 |
|                                | <b>Index</b>                              |     |
|                                | .....                                     | 105 |

**Notes:**

This manual is a user guide for 6181P integrated display and non-display industrial computer models. It provides procedures to the following:

- Install the computer.
- Make computer connections.
- Operate the computer.
- Troubleshoot the computer.

## Summary of Changes

This manual contains new and updated information as indicated in the following table.

| <b>Topic</b>   | <b>Page</b> |
|--|-------------|
| Added UIB to Abbreviations table.  | 8           |
| Added publication IC-TD001 to the Additional Resources table.                                | 8           |
| Replaced all Chapter Objectives sections with topic tables.                                  | Throughout  |
| Revised introductory paragraph to Computer Options section.                                  | 10          |
| Moved Before You Begin and Parts Lists sections from Chapter 1 to Chapter 2.                 | 19          |
| Updated EN 55022 to EN 55032 in European Union Directive section.                            | 21          |
| Added ambient temperature ranges for all computer models in Installation Guidelines section. | 21          |
| Added ambient air humidity range in Installation Guidelines section.                         | 22          |
| Updated ground wire recommendations in step 7 of the Connect DC Power section.               | 34          |
| Updated ground wire recommendations in step 7 of the Connect DC Power section.               | 35          |
| Change abbreviation from Gigabyte (GB) to Gigabit (Gb) for Ethernet LAN cable speed.         | 36          |
| Updated hypertext link in Accessories and Replacement Parts section.                         | 41          |
| Added step 3 in the Replace or Add a Memory Module section.                                  | 48          |
| Added the first paragraph to the Set-up Utility Overview section.                            | 55          |
| Consolidated RAID mode information into AHCI Mode table rows 1 and 2.                        | 64          |
| Modified screen shot for AMT Configuration so it shows only default settings.                | 71          |
| Added Important sentence to Unconfigure AMT/ME table row.                                    | 71          |
| Replaced screen shot with text for boot priority list in Boot Priorities table row.          | 75          |
| Added text and links to both table rows in Security section.                                 | 76          |
| Updated the text in the first Important table of the Make a Backup section.                  | 82          |
| Added first Important table and revised access methods in Diagnostics section.               | 89          |
| Updated Available Accessories section.   | 99          |

## Abbreviations

The following abbreviations are used in this publication.

| Abbr | Meaning                                       | Abbr | Meaning                                   |
|------|---|------|---|
| ACPI | Advanced configuration (and) power interface  | PCDC | Product Compatibility and Download Center |
| AHCI | Advanced host controller interface            | PCH  | Platform control hub                      |
| AMI  | American Megatrends, Inc.                     | PCI  | Peripheral component interconnect         |
| AMT  | Active management technology                  | PCIe | Peripheral component interconnect express |
| BIOS | Basic input/output system                     | PELV | Protective extra-low voltage              |
| CF   | CompactFlash                                  | PERR | PCI parity error                          |
| CPU  | Central processing unit                       | POST | Power on self test                        |
| COM  | Communication (serial port interface)         | PSU  | Power supply unit                         |
| DDR  | Double data rate (RAM)                        | PXE  | Pre-boot execution environment            |
| DIMM | Dual in-line memory module                    | RAID | Redundant array (of) independent disks    |
| DP   | DisplayPort (digital display interface)       | RAM  | Random access memory                      |
| eDP  | Embedded DisplayPort                          | RTC  | Real-time clock                           |
| EEA  | European Environment Agency                   | SATA | Serial advanced technology attachment     |
| EMC  | Electromagnetic compatibility                 | SCSI | Small computer system interface           |
| ESD  | Electrostatic discharge                       | SELV | Safety extra-low voltage                  |
| FAT  | File allocation table                         | SERR | PCI signal error                          |
| HDD  | Hard disk drive                               | SPD  | Serial presence detect                    |
| IDE  | Integrated device electronics                 | SSD  | Solid state drive                         |
| IEC  | International Engineering Consortium          | UEFI | Universal extensible firmware interface   |
| LAN  | Local area network                            | UIB  | User interface button                     |
| NEMA | National Electrical Manufacturers Association | USB  | Universal serial bus                      |
| ODD  | Optical disk drive                            | UPS  | Uninterruptible power source              |
| OSK  | On screen keyboard                            | VBAT | Voltage (battery)                         |
| PCAP | Protective capacitive (touchscreen)           | VDDR | Voltage (DDR RAM)                         |
| PCB  | Printed circuit board                         | VGA  | Video graphics array                      |

## Additional Resources

These documents contain additional information to related products from Rockwell Automation.

| Resource   | Description   |
|--|---|
| Industrial Computer and Monitor Specifications Technical Data, publication <a href="#">IC-TD001</a>  | Provides technical specifications for the 6181P integrated display and non-display computers. |
| Industrial Integrated Display Computers Product Information, publication <a href="#">6181P-PC001</a> | Provides basic product information on the integrated display computers.                       |
| Industrial Automation Wiring and Grounding Guidelines, publication <a href="#">1770-4.1</a>          | Provides general guidelines for installing a Rockwell Automation® industrial system.          |

You can view or download publications at <http://www.rockwellautomation.com/literature>. To order paper copies of technical documentation, contact your local Allen-Bradley distributor or Rockwell Automation sales representative.



## Features

| Topic             | Page |
|-------------------|------|
| Operating Systems | 9    |
| Computer Options  | 10   |
| Hardware Features | 12   |
| System Features   | 15   |

## Operating Systems

The following Microsoft-licensed operating systems are available:

- Windows 7 Professional (64 bit), Service Pack 1
- Windows XP Professional, Service Pack 3
- Windows Server 2008 R2 Standard (64 bit), Service Pack 1
- Windows Embedded Standard (WES) 7 (64 bit), Service Pack 1

No operating system updates have been applied to the factory image beyond the above listed service packs.

---

**IMPORTANT** 6181P computers do not ship with the Windows XP Professional operating system. Windows XP system images are available from the Rockwell Automation Product Compatibility and Download Center: <http://www.rockwellautomation.com/support/pcdc.page>.

---

To obtain a copy of a factory system image, contact your local technical support center or access the Rockwell Automation Product Compatibility and Download Center (PCDC): <http://www.rockwellautomation.com/support/pcdc.page>.

## Computer Options

This table summarizes options available for 6181P industrial computers. A comparative summary of features for the computers is in Industrial Computers and Monitors Specifications Technical Data, publication [IC-TD001](#).

**Table 1 - Computer Options**

| Cat. No. (6181P-) | Model | Tier <sup>(1)</sup> | Series           | Power            | Display Size (in.) | Aspect Ratio               | Touchscreen | Bezel              | Storage          | Windows OS                |     |
|-------------------|-------|---------------------|------------------|------------------|--------------------|----------------------------|-------------|--------------------|------------------|---------------------------|-----|
| 00N2HW71AC        | NDM   | 2                   | F                | AC               | N/A                | N/A                        | N/A         | None (non-display) | HDD              | 7 Professional 64 bit SP1 |     |
| 00N2HW71DC        |       |                     |                  | DC               |                    |                            |             |                    |                  |                           |     |
| 00N2SW71AC        |       |                     |                  | AC               |                    |                            |             |                    | SSD              |                           |     |
| 00N2SW71DC        |       |                     |                  | DC               |                    |                            |             |                    |                  |                           |     |
| 00N2SE71AC        |       |                     |                  | AC               |                    |                            |             |                    | WES 7 64 bit SP1 |                           |     |
| 00N2SE71DC        |       |                     |                  | DC               |                    |                            |             |                    |                  |                           |     |
| 00N3HW71AC        |       |                     |                  | 3                |                    |                            |             |                    | AC               |                           | HDD |
| 00N3HW71DC        |       | DC                  |                  |                  |                    |                            |             |                    |                  |                           |     |
| 00N3SW71AC        |       | AC                  |                  |                  | SSD                |                            |             |                    |                  |                           |     |
| 00N3SW71DC        |       | DC                  |                  |                  |                    |                            |             |                    |                  |                           |     |
| 00N3RS81AC        |       | AC                  |                  |                  | HDD (2)            | Server 2008 R2 64 bit SP 1 |             |                    |                  |                           |     |
| 00N3RS81DC        |       | DC                  |                  |                  |                    |                            |             |                    |                  |                           |     |
| 12A2HW71AC        |       | 1200P               |                  |                  | 2                  | AC                         | 12          | 4:3                | Resistive        | Aluminum                  | HDD |
| 12A2HW71DC        |       |                     |                  | DC               |                    |                            |             |                    |                  |                           |     |
| 12A2SW71AC        | AC    |                     | SSD              |                  |                    |                            |             |                    |                  |                           |     |
| 12A2SW71DC        | DC    |                     |                  |                  |                    |                            |             |                    |                  |                           |     |
| 12A2SE71AC        | AC    |                     | WES 7 64 bit SP1 |                  |                    |                            |             |                    |                  |                           |     |
| 12A2SE71DC        | DC    |                     |                  |                  |                    |                            |             |                    |                  |                           |     |
| 15A2HW71AC        | 1500P |                     | 2                | AC               |                    | 15                         |             |                    |                  |                           | 4:3 |
| 15A2HW71DC        |       | DC                  |                  |                  |                    |                            |             |                    |                  |                           |     |
| 15A2SW71AC        |       | AC                  |                  | SSD              |                    |                            |             |                    |                  |                           |     |
| 15A2SW71DC        |       | DC                  |                  |                  |                    |                            |             |                    |                  |                           |     |
| 15A2SE71AC        |       | AC                  |                  | WES 7 64 bit SP1 |                    |                            |             |                    |                  |                           |     |
| 15A2SE71DC        |       | DC                  |                  |                  |                    |                            |             |                    |                  |                           |     |
| 15C2HW71AC        |       | 3                   |                  | AC               | 15 <sup>(2)</sup>  |                            | 16:9        | PCAP               | Aluminum         | HDD                       |     |
| 15C2HW71DC        |       |                     | DC               |                  |                    |                            |             |                    |                  |                           |     |
| 15C2SW71AC        |       |                     | AC               | SSD              |                    |                            |             |                    |                  |                           |     |
| 15C2SW71DC        |       |                     | DC               |                  |                    |                            |             |                    |                  |                           |     |
| 15A3HW71AC        |       |                     | AC               | HDD              |                    |                            |             |                    |                  |                           |     |
| 15A3HW71DC        |       |                     | DC               |                  |                    |                            |             |                    |                  |                           |     |
| 15A3SW71AC        |       |                     | AC               | SSD              |                    |                            |             |                    |                  |                           |     |
| 15A3SW71DC        |       | DC                  |                  |                  |                    |                            |             |                    |                  |                           |     |
| 15B3HW71AC        | AC    | HDD                 |                  |                  |                    |                            |             |                    |                  |                           |     |
| 15B3HW71DC        | DC    |                     |                  |                  |                    |                            |             |                    |                  |                           |     |
| 15B3SW71AC        | AC    |                     | SSD              |                  |                    |                            |             |                    |                  |                           |     |
| 15B3SW71DC        | DC    |                     |                  |                  |                    |                            |             |                    |                  |                           |     |

**Table 1 - Computer Options (continued)**

| Cat. No. (6181P-) | Model | Tier <sup>(1)</sup> | Series | Power | Display Size (in.) | Aspect Ratio | Touchscreen | Bezel    | Storage          | Windows OS                |     |                           |  |      |          |     |  |
|-------------------|-------|---------------------|--------|-------|--------------------|--------------|-------------|----------|------------------|---------------------------|-----|---------------------------|--|------|----------|-----|--|
| 17A2HW71AC        | 1700P | 2                   | F      | AC    | 17                 | 5:4          | Resistive   | Aluminum | HDD              | 7 Professional 64 bit SP1 |     |                           |  |      |          |     |  |
| 17A2HW71DC        |       |                     |        | DC    |                    |              |             |          |                  |                           |     |                           |  |      |          |     |  |
| 17A2SW71AC        |       |                     |        | AC    |                    |              |             |          |                  |                           | SSD |                           |  |      |          |     |  |
| 17A2SW71DC        |       |                     |        | DC    |                    |              |             |          |                  |                           |     |                           |  |      |          |     |  |
| 17A2SE71AC        |       |                     |        | AC    |                    |              |             |          | WES 7 64 bit SP1 |                           |     |                           |  |      |          |     |  |
| 17A2SE71DC        |       |                     |        | DC    |                    |              |             |          |                  |                           |     |                           |  |      |          |     |  |
| 17C2HW71AC        |       |                     |        | AC    |                    |              |             |          | Stainless steel  |                           | HDD | 7 Professional 64 bit SP1 |  |      |          |     |  |
| 17C2HW71DC        |       |                     |        | DC    |                    |              |             |          |                  |                           |     |                           |  |      |          |     |  |
| 17C2SW71AC        |       |                     |        | AC    |                    |              |             |          | SSD              |                           |     |                           |  |      |          |     |  |
| 17C2SW71DC        |       |                     |        | DC    |                    |              |             |          |                  |                           |     |                           |  |      |          |     |  |
| 17A3HW71AC        |       |                     |        | 3     |                    |              |             |          |                  |                           | AC  |                           |  | PCAP | Aluminum | HDD |  |
| 17A3HW71DC        |       |                     |        |       |                    |              |             |          |                  |                           | DC  |                           |  |      |          |     |  |
| 17A3SW71AC        |       |                     |        |       |                    |              |             |          |                  |                           | AC  |                           |  |      |          | SSD |  |
| 17A3SW71DC        |       |                     |        |       |                    |              |             |          |                  |                           | DC  |                           |  |      |          |     |  |
| 19A2HW71AC        | 1900P | 2                   |        | AC    | 19                 | 5:4          | Resistive   | Aluminum | HDD              | 7 Professional 64 bit SP1 |     |                           |  |      |          |     |  |
| 19A2HW71DC        |       |                     |        | DC    |                    |              |             |          |                  |                           |     |                           |  |      |          |     |  |
| 19A2SW71AC        |       |                     |        | AC    |                    |              |             |          |                  |                           | SSD |                           |  |      |          |     |  |
| 19A2SW71DC        |       |                     |        | DC    |                    |              |             |          |                  |                           |     |                           |  |      |          |     |  |
| 19A2SE71AC        |       |                     |        | AC    |                    |              |             |          | WES 7 64 bit SP1 |                           |     |                           |  |      |          |     |  |
| 19A2SE71DC        |       |                     |        | DC    |                    |              |             |          |                  |                           |     |                           |  |      |          |     |  |
| 19C2HW71AC        |       |                     |        | AC    |                    |              |             |          | Stainless steel  |                           | HDD | 7 Professional 64 bit SP1 |  |      |          |     |  |
| 19C2HW71DC        |       |                     |        | DC    |                    |              |             |          |                  |                           |     |                           |  |      |          |     |  |
| 19C2SW71AC        |       |                     |        | AC    |                    |              |             |          | SSD              |                           |     |                           |  |      |          |     |  |
| 19C2SW71DC        |       |                     |        | DC    |                    |              |             |          |                  |                           |     |                           |  |      |          |     |  |
| 19A3HW71AC        |       |                     |        | 3     |                    |              |             |          |                  |                           | AC  |                           |  | PCAP | Aluminum | HDD |  |
| 19A3HW71DC        |       |                     |        |       |                    |              |             |          |                  |                           | DC  |                           |  |      |          |     |  |
| 19A3SW71AC        |       |                     |        |       |                    |              |             |          |                  |                           | AC  |                           |  |      |          | SSD |  |
| 19A3SW71DC        |       |                     |        |       |                    |              |             |          |                  |                           | DC  |                           |  |      |          |     |  |
| 19B3HW71AC        |       |                     |        | AC    | 19 <sup>(1)</sup>  | 16:9         |             |          | HDD              |                           |     |                           |  |      |          |     |  |
| 19B3HW71DC        |       |                     |        | DC    |                    |              |             |          |                  |                           |     |                           |  |      |          |     |  |
| 19B3SW71AC        |       |                     |        | AC    |                    |              |             |          | SSD              |                           |     |                           |  |      |          |     |  |
| 19B3SW71DC        |       |                     |        | DC    |                    |              |             |          |                  |                           |     |                           |  |      |          |     |  |

(1) Tier 2 computer models have Intel Core i3 processors and Tier 3 computer models have Intel Core i7 processors.

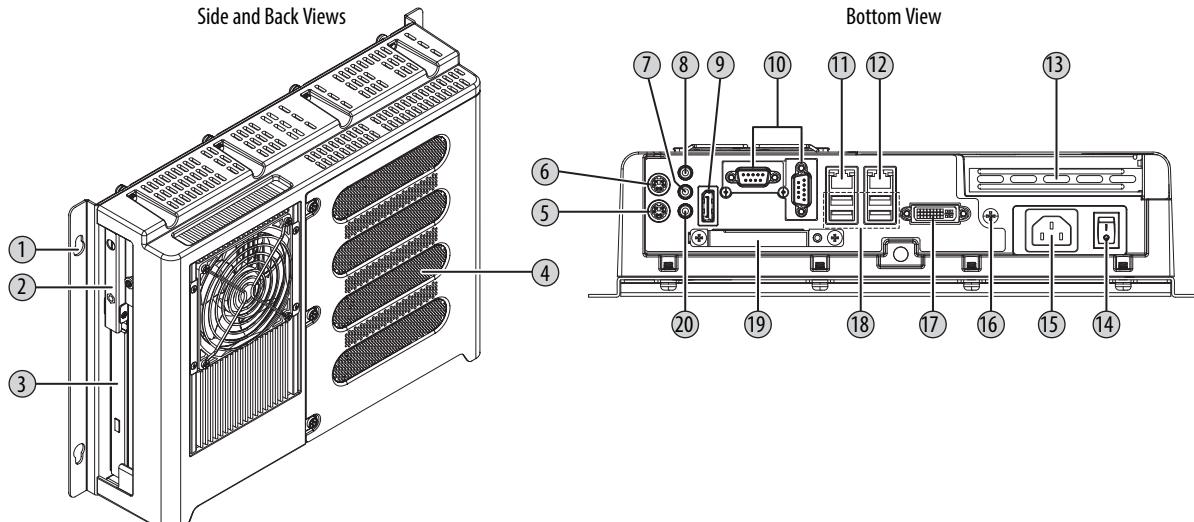
(2) 15.6 inches and 18.5 inches for diagonal sizes of 15 and 19 inch widescreen displays, respectively.

# Hardware Features

The illustrations in this section show the hardware features of each computer.

## External Components and I/O

Figure 1 - Non-display Computers



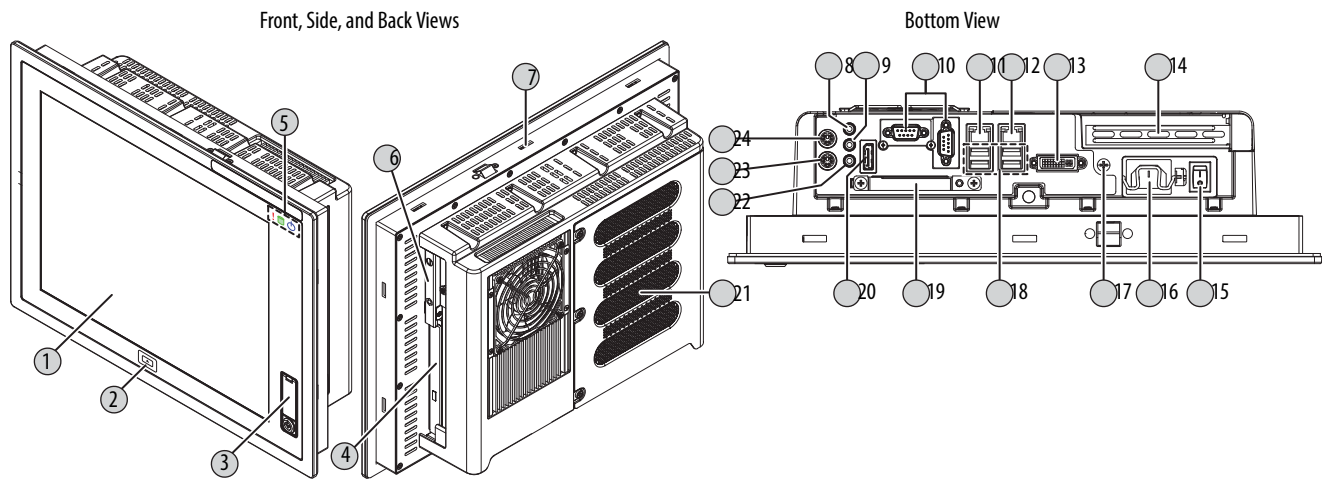
| Item | Component                |
|------|--------------------------|
| 1    | Mounting hole, 4         |
| 2    | HDD or SSD               |
| 3    | Drive bay <sup>(1)</sup> |
| 4    | Rear cover               |
| 5    | PS/2 keyboard port       |
| 6    | PS/2 mouse port          |
| 7    | Audio line-out jack      |

| Item | Component                       |
|------|---------------------------------|
| 8    | Audio line-in jack              |
| 9    | DisplayPort connector           |
| 10   | Serial COM ports, 2             |
| 11   | LAN 2 Ethernet port (8P8C/RJ45) |
| 12   | LAN 1 Ethernet port (8P8C/RJ45) |
| 13   | PCIe x8 riser slot cover        |
| 14   | Power switch                    |

| Item | Component                                |
|------|--|
| 15   | Power input, AC or DC <sup>(2)</sup>     |
| 16   | Functional ground screw                  |
| 17   | DVI-I port                               |
| 18   | External USB 3.0 ports, 4 <sup>(3)</sup> |
| 19   | CompactFlash Type II card slot           |
| 20   | Microphone-in jack                       |

- (1) Bay for ODD, second HDD (for RAID configuration), or no drive.
- (2) Model dependent.
- (3) All non-display models have four external USB 3.0 ports and one internal USB 3.0 port.

Figure 2 - Integrated Display Computers



| Item | Component                                  |
|------|--|
| 1    | Touchscreen and display panel              |
| 2    | User interface button (UIB) <sup>(1)</sup> |
| 3    | Front access cover <sup>(2)</sup>          |
| 4    | ODD <sup>(2)</sup>                         |
| 5    | Status indicator icons, 3 <sup>(2)</sup>   |
| 6    | HDD or SSD                                 |
| 7    | Mounting slots                             |
| 8    | Audio line-in jack                         |

| Item | Component                            |
|------|--------------------------------------|
| 9    | Audio line-out jack                  |
| 10   | Serial COM ports, 2                  |
| 11   | LAN 2 Ethernet port (8P8C/RJ45)      |
| 12   | LAN 1 Ethernet port (8P8C/RJ45)      |
| 13   | DVI-I port                           |
| 14   | PCIe x8 riser slot cover             |
| 15   | Power switch                         |
| 16   | Power input, AC or DC <sup>(3)</sup> |

| Item | Component                                |
|------|--|
| 17   | Functional ground screw                  |
| 18   | External USB 3.0 ports, 4 <sup>(4)</sup> |
| 19   | CompactFlash Type II card slot           |
| 20   | DisplayPort connector                    |
| 21   | Rear cover                               |
| 22   | Microphone-in jack                       |
| 23   | PS/2 keyboard port                       |
| 24   | PS/2 mouse port                          |

(1) Available only on display models with aluminum bezel.

(2) An ODD is not available on all display models.

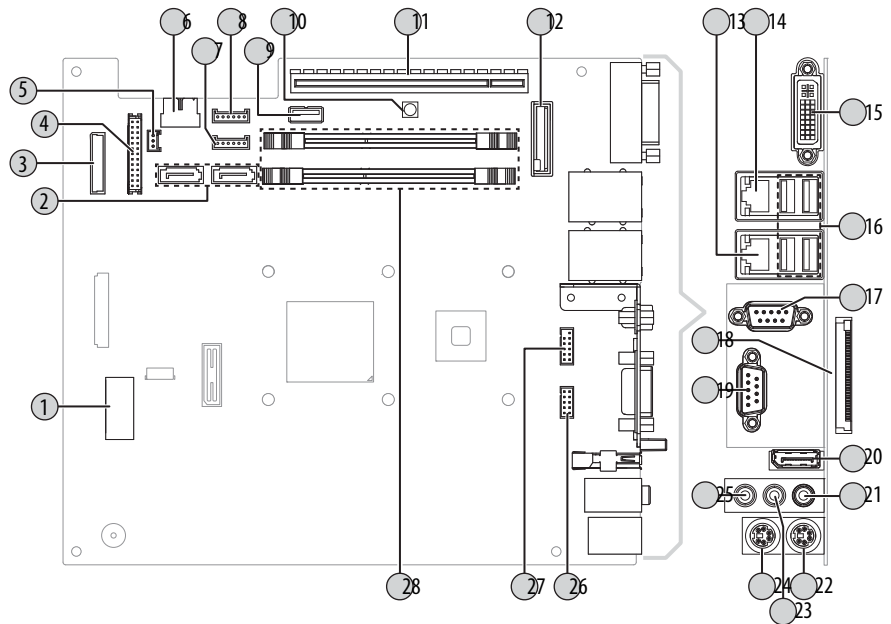
(3) Model dependent.

(4) All display models have four external USB 3.0 ports and one internal USB 3.0 port. Display models with an aluminum bezel have an additional external USB 3.0 port on the bezel (behind the front access cover).

## Internal Components

The illustrations in this section show the system board layouts for all non-display and display computers.

**Figure 3 - Motherboard**

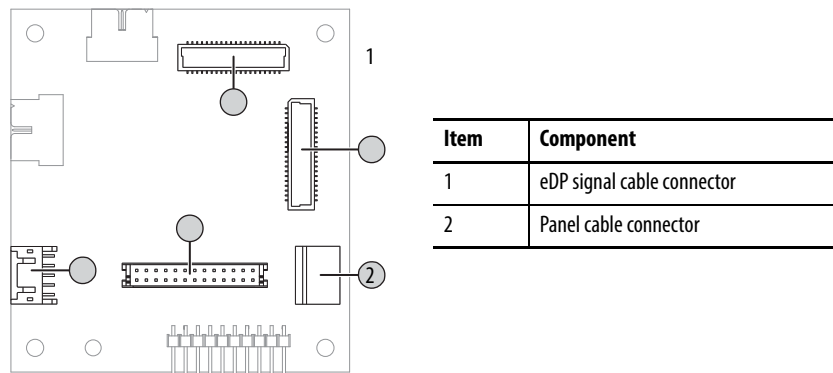


| Item | Component                         |
|------|-----------------------------------|
| 1    | Power connector                   |
| 2    | Mini-SATA cable connector, 2      |
| 3    | eDP signal cable connector        |
| 4    | Panel cable connector             |
| 5    | Power switch cable connector      |
| 6    | USB cable connector               |
| 7    | ODD and HDD power cable connector |
| 8    | System fan 1 connector            |
| 9    | Internal USB 3.0 connector        |

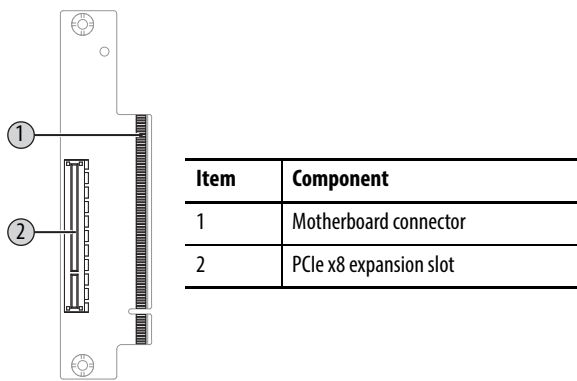
| Item | Component                  |
|------|----------------------------|
| 10   | Clear UEFI button          |
| 11   | Riser-card board connector |
| 12   | Battery socket             |
| 13   | 1 Gb LAN 2 port            |
| 14   | 1 Gb LAN 1 port            |
| 15   | DVI-I port                 |
| 16   | Rear USB 3.0 ports, 4      |
| 17   | RS-232 serial port, (COM2) |
| 18   | CompactFlash Type II slot  |
| 19   | RS-232 serial port (COM1)  |

| Item | Component             |
|------|-----------------------|
| 20   | DisplayPort connector |
| 21   | Microphone-in jack    |
| 22   | PS/2 keyboard port    |
| 23   | Audio line-out jack   |
| 24   | PS/2 mouse port       |
| 25   | Audio line-in jack    |
| 26   | COM1 cable connector  |
| 27   | COM2 cable connector  |
| 28   | DDR3 DIMM slot, 2     |

**Figure 4 - Panel Adapter Board (only in display models)**



**Figure 5 - Riser-card Board, Single-slot**



## System Features

The following system features are found on this line of integrated display computers.

### Multi-touch Touchscreens

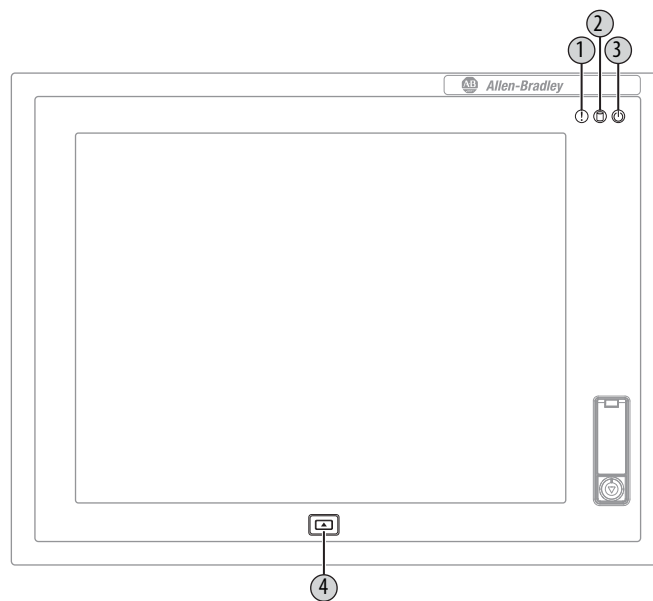
The 6181P integrated display industrial computers offer models with glass-front, multi-touch PCAP touchscreens. The multi-touch technology provides up to two simultaneous touches and common gesturing (such as flicking, rotating and pinch-to-zoom) when operating the touchscreen. These touchscreens can also be operated with gloves.

PCAP touchscreens are pre-calibrated at the factory so re-calibration by the user is not necessary. The touchscreen glass has an anti-reflective coating, which results in a visually appealing and durable touchscreen ideal for industrial applications.

## Status Indicators and UIB

Display computers with aluminum bezels have three status indicators and a UIB on the front panel. The status indicators provide a quick, at-a-glance view of the computer's status for system temperature, drive activity, and power. Complete descriptions of the indicators are shown in the table below.

The UIB provides users with an easy, one-click access to either the BIOS/UEFI upon startup or applications in the operating system (OS). The functionality can be configured to be any keystroke (up to three keystrokes) in the OS or can be disabled all-together. Configuration of this button is done in the BIOS/UEFI. See [User Interface Button \(UIB\) on page 73](#) for more information on configuring the UIB.



| Item | Icon          | Indicator                   | Status | Description  |
|------|---------------|-----------------------------|--------|--|
| 1    | !             | System health status        | Red    | The computer's temperature threshold has been exceeded.  |
|      |               |                             | Off    | System health is normal.   |
| 2    | Cylinder icon | Drive access status         | Green  | HDD, SSD, or ODD activity.   |
|      |               |                             | Off    | No HDD, SSD, or ODD activity.  |
| 3    | Power icon    | Power status                | Blue   | The computer is operating.   |
|      |               |                             | Amber  | The computer is in Standby mode.   |
|      |               |                             | Off    | The computer is off.   |
| 4    | UIB icon      | User Interface Button (UIB) | N/A    | The UIB can be used as a programmable navigation button. Press during computer startup to access the UEFI. See <a href="#">User Interface Button (UIB) on page 73</a> for configuring the UIB. |



## Hardware Monitor and Watchdog Timer Utilities

The 6181P computer system images are provided with an integrated Hardware Monitor utility and a Watchdog Timer service. The utilities are available in the images but must be installed and enabled by the user.

### *Hardware Monitor*

The Hardware Monitor is an integrated utility that runs on the OS. It monitors the computer temperature and views the system fan speed (if a fan is present). This utility is similar to what a user sees when running a third party program, such as SpeedFan.

Hardware Monitor has a default temperature threshold that can be adjusted by the user. Once the temperature threshold is selected and the service is running, the utility displays a pop-up message on the display, indicating that the computer has reached the selected temperature threshold. There is no action taken as a result of the pop-up and there are no event logs created.

### *Watchdog Timer*

Watchdog timer is a utility that runs on the OS and ‘watches’ the system. If there is a program error or hardware malfunction that causes the OS to ‘hang,’ the watchdog timer times out and causes the system to automatically reboot. An event log is created after the system restarts because the computer experienced an incorrect shutdown sequence.

This utility is beneficial for situations where constant user interface is not possible, and it is desired to keep the computer up and running for visual and display purposes.

See [Watchdog Timer on page 74](#) for more information on configuring the watchdog timer.

## Intel Active Management Technology (AMT) 9.0

Intel Active Management Technology (AMT) 9.0 is supported on 6181P computers with the Intel Core i7 Quad-core processor. AMT provides remote access and manages products through either the BIOS/UEFI or OS. By default, the 6181P computers are shipped with the AMT disabled. The user must enable it to take advantage of the remote management capabilities. For additional information on Intel AMT, visit <http://www.intel.com>.

See [AMT Configuration on page 71](#) for more information on configuring the AMT.

## Intel Rapid Start Technology

Rapid Start can set up the computer for a quick resume into the OS from a deep sleep state in a matter of seconds. For additional information on Intel Rapid Start, visit <http://www.intel.com>.

---

**IMPORTANT** The SSD must first have a private partition allocated that is equal in size to the computer RAM.

---

See [Intel Rapid Start Technology on page 68](#) for more information on configuring Rapid Start.

## Install the Computer

| Topic                           | Page |
|---------------------------------|------|
| Before You Begin                | 19   |
| Parts List                      | 19   |
| Installation Precautions        | 20   |
| Installation Guidelines         | 21   |
| Mounting Clearance Requirements | 22   |
| Computer Dimensions             | 23   |
| Tools for Computer Installation | 27   |
| Install the Computer            | 27   |
| Connect Peripherals             | 32   |
| Connect Power                   | 33   |
| Functional Ground Screw         | 35   |
| Connect to a Network            | 36   |

### Before You Begin

Before unpacking the computer, inspect the shipping carton for damage. If damage is visible, immediately contact the shipper and request assistance. Otherwise, proceed with unpacking.

Keep the original packing material in case you need to return the computer for repair or transport it to another location. Use both the inner and outer packing cartons to provide adequate protection for a computer returned for service.

### Parts List

The computers ship with the following items.

| Item      | Description  |
|-----------|--|
| Hardware  | <ul style="list-style-type: none"> <li>Power cord for AC power models</li> <li>Mounting clips<sup>(1)</sup></li> <li>Keys for front access cover lock<sup>(2)</sup></li> <li>Assembly screw bag</li> </ul>   |
| Documents | <ul style="list-style-type: none"> <li>Integrated Display Industrial Computers Product Information, publication <a href="#">6181P-PC001</a></li> <li>One of the following cutout templates:               <ul style="list-style-type: none"> <li>6181P and 6181X Industrial Computers Cutout Template for Standard Display Models (4:3 and 5:4 aspect ratios), publication <a href="#">6181P-DS002</a><sup>(1)</sup></li> <li>6181P and 6181X Industrial Computers Cutout Template for Widescreen Display Models (16:9 aspect ratio), publication <a href="#">6181P-DS003</a><sup>(1)</sup></li> </ul> </li> <li>Production test report</li> </ul> |

(1) Shipped only with display computers.

(2) Shipped only with computers with aluminum bezels; see the table in [Computer Options on page 10](#) for more information.

## Installation Precautions

Read and follow these precautions before installing the computer.

### Environment and Enclosure Information

---



**ATTENTION:** This equipment is intended for use in a Pollution Degree 2 industrial environment, in overvoltage Category II applications (as defined in IEC 60664-1), at altitudes up to 2000 m (6561 ft) without derating.

This equipment is considered Group 1, Class A industrial equipment according to IEC/CISPR 22. Without appropriate precautions, there can be potential difficulties with electromagnetic compatibility in other environments due to conducted as well as radiated disturbance.

This equipment is UL Listed and supplied as an open type equipment. To meet some regulatory requirements, the computer must be mounted in an enclosure that is suitably designed for environmental conditions that can be present and appropriately designed to prevent personal injury resulting from accessibility to live parts. The enclosure must be accessible only by using a tool.

All 6181P display computers are shipped with a gasketed bezel to meet specified NEMA, UL Type, and IEC IP ratings only when mounted in a panel or enclosure with an equivalent rating.

In addition to this publication, see the following:

- Industrial Automation Wiring and Grounding Guidelines, publication [1770-4.1](#), for additional installation requirements
  - NEMA 250 and IEC 60529, as applicable, for explanations of the degrees of protection provided by enclosures
- 

### European Union Directive

This computer meets the European Union Directive requirements when installed within the European Union or EEA regions and have the CE mark. A copy of the declaration of the conformity is available at <http://www.rockwellautomation.com/certification>.

---



**ATTENTION:** This computer is intended to operate in an industrial or control room environment, which uses some form of power isolation from the public low-voltage mains. Some computer configurations cannot comply with the EN 61000-3-2 Harmonic Emissions standard as specified by the EMC Directive of the European Union. Obtain permission from the local power authority before connecting any computer configuration that draws more than 75 W of AC power directly from the public mains.

To comply with EN 55024, the Ethernet port LAN cable must be used only indoors. All other I/O cables must be less than 3 m (9.84 ft) and used only indoors.

---

To comply with EN 55024 and EN 55032, use the following for cable types.

| Cable Type    | Required Attribute        |
|---------------|---------------------------|
| LAN           | Shielded or unshielded    |
| USB           | Shielded                  |
| Serial RS-232 | Shielded                  |
| DVI           | Shielded                  |
| DP            | Shielded                  |
| VGA           | Shielded                  |
| DC power      | Unshielded                |
| AC power      | Unshielded <sup>(1)</sup> |

(1) Use the AC power cord shipped with the computer.

## Installation Guidelines

Follow these guidelines to make sure your computer provides service with excellent reliability:

- The installation site must have sufficient power.



**ATTENTION:** To maintain an electrically safe installation, AC powered computers must be plugged into a grounded outlet.

- In dry environments, static charges can build up easily. A properly grounded computer helps to reduce static discharges, which can cause shock and damage electronic components.
- The enclosure must allow sufficient space around air inlets and outlets to provide the circulation necessary for cooling. See [Mounting Clearance Requirements on page 22](#) for further information. Never allow air passages to become obstructed.
- The ambient air temperature must not exceed the maximum operating temperature as follows:
  - Non-display, 12 in. (4:3), 15 in. (4:3), and 17 in. (5:4) computer models: 0...55 °C (32...131 °F)
  - 15.6 in. (16:9), 18.5 in. (16:9), and 19 in. (5:4) computer models: 0...50 °C (32...122 °F)
- Consider a user-supplied fan, heat exchanger, or air conditioner for heat from other devices in the enclosure.

**TIP** Hot air rises. The temperature at the top of the enclosure is often higher than the temperature in other parts of the enclosure, especially when air does not circulate.

**IMPORTANT** The computer can operate at a range of extremes. However, the life span of the computer is shortened if you continuously operate it at its highest rated temperature.

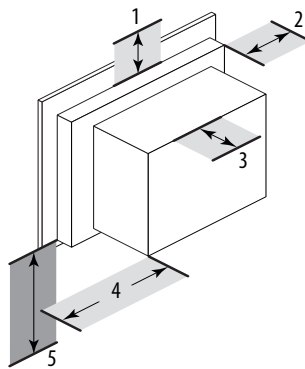
- The humidity of the ambient air must not exceed 10...90% noncondensing at 50%.
- The enclosure or cover must always remain in place during operation. The cover provides protection against high voltages inside the computer and inhibits radio-frequency emissions that can interfere with other equipment.

## Mounting Clearance Requirements

**IMPORTANT** Computers generate heat. Therefore, do not operate the computer in an enclosure with the minimum clearances unless adequate ventilation or other cooling methods are used to lower the temperature within the enclosure.

Allow enough clearance to easily install or remove peripheral components, such as storage drives.

**Figure 6 - Minimum Clearances**



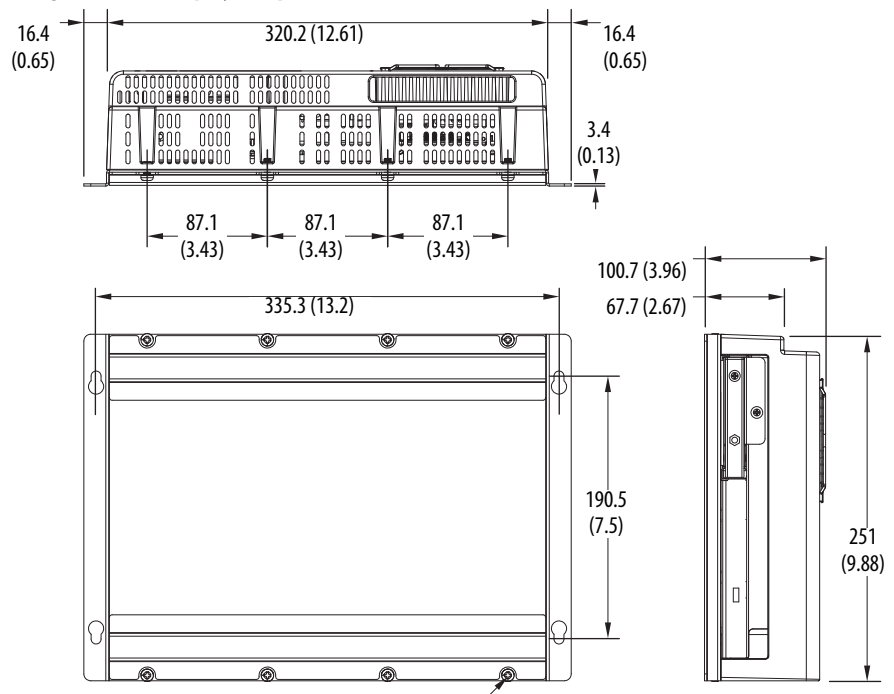
| Item | Description                                  | Value          |
|------|--|----------------|
| 1    | Top  | 50 mm (2 in.)  |
| 2    | Left (for airflow)                           | 50 mm (2 in.)  |
| 3    | Rear   | 50 mm (2 in.)  |
| 4    | Right (for airflow and drive access)         | 127 mm (5 in.) |
| 5    | Bottom (for I/O port access and ventilation) | 102 mm (4 in.) |

Right and left are based on facing the front of the computer.

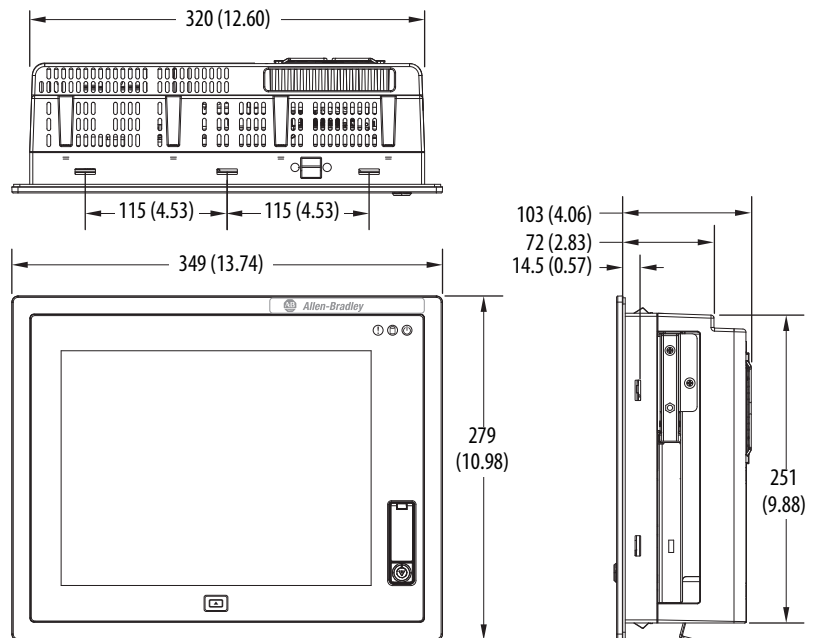
# Computer Dimensions

Review computer dimensions to estimate the clearance necessary for computer installation. Dimensions are given in mm (in.).

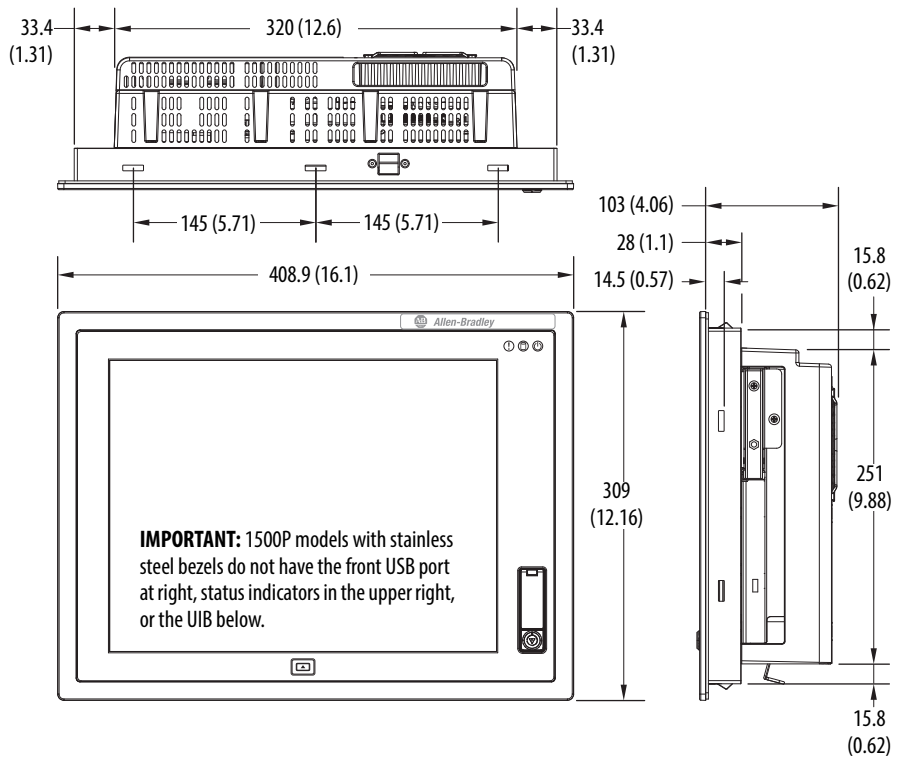
**Figure 7 - Non-display Computer**



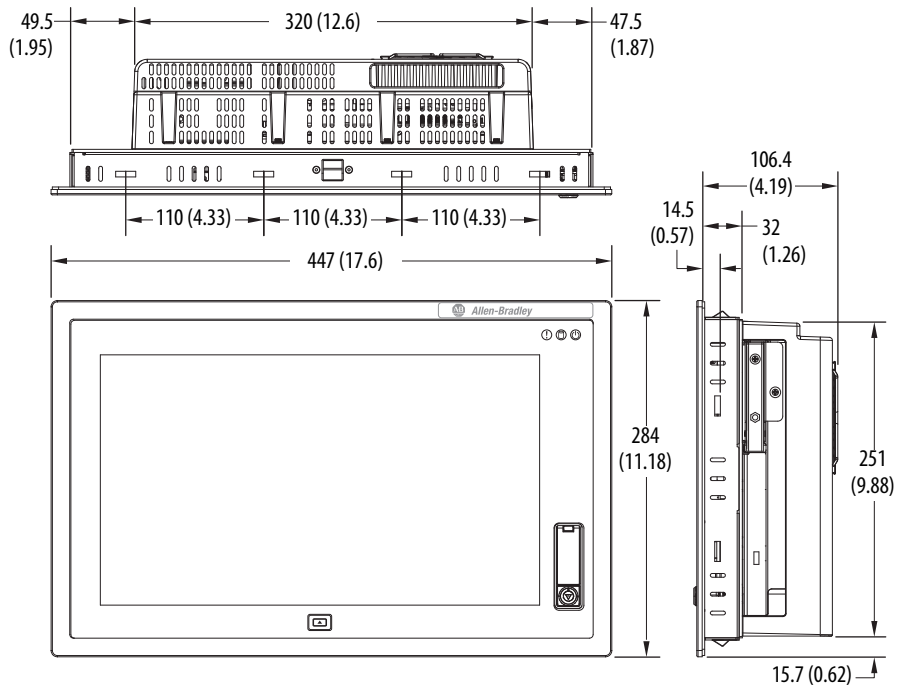
**Figure 8 - 1200P (12-inch) Standard Display Computer**



**Figure 9 - 1500P (15-inch) Standard Display Computer**

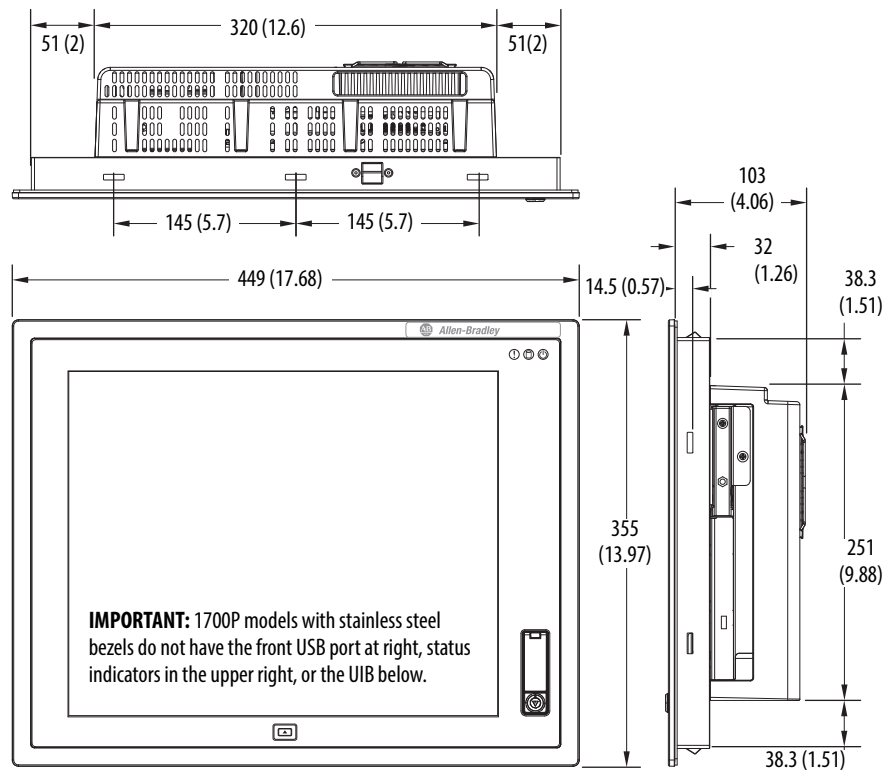


**Figure 10 - 1500P (15-inch) Widescreen Display Computer**





**Figure 11 - 1700P (17-inch) Standard Display Computer**



**Figure 12 - 1900P (19-inch) Standard Display Computer**

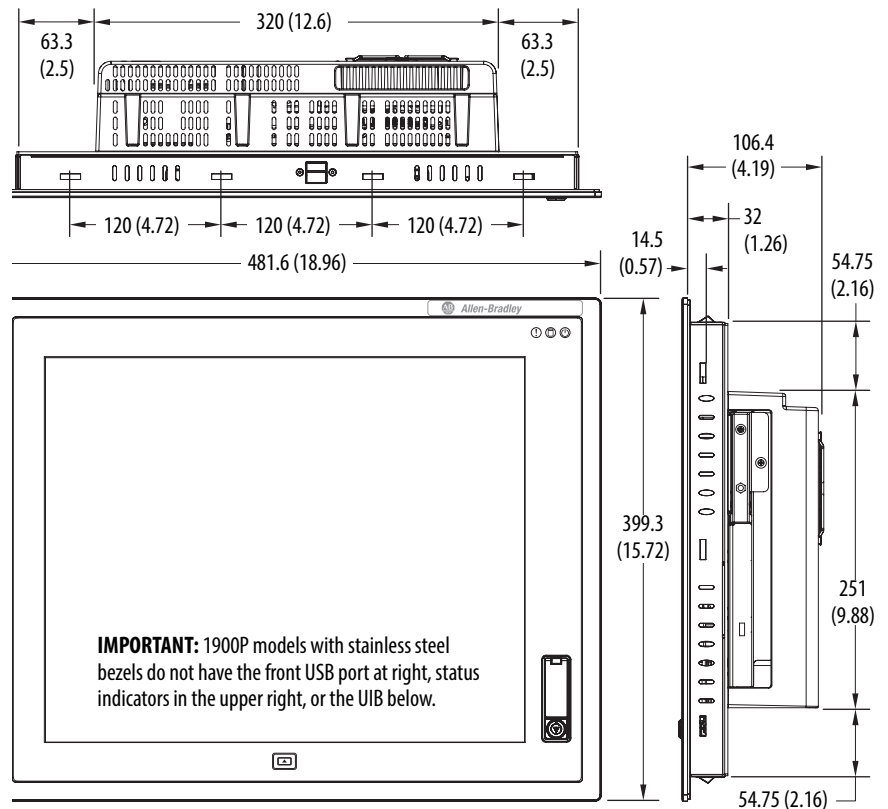
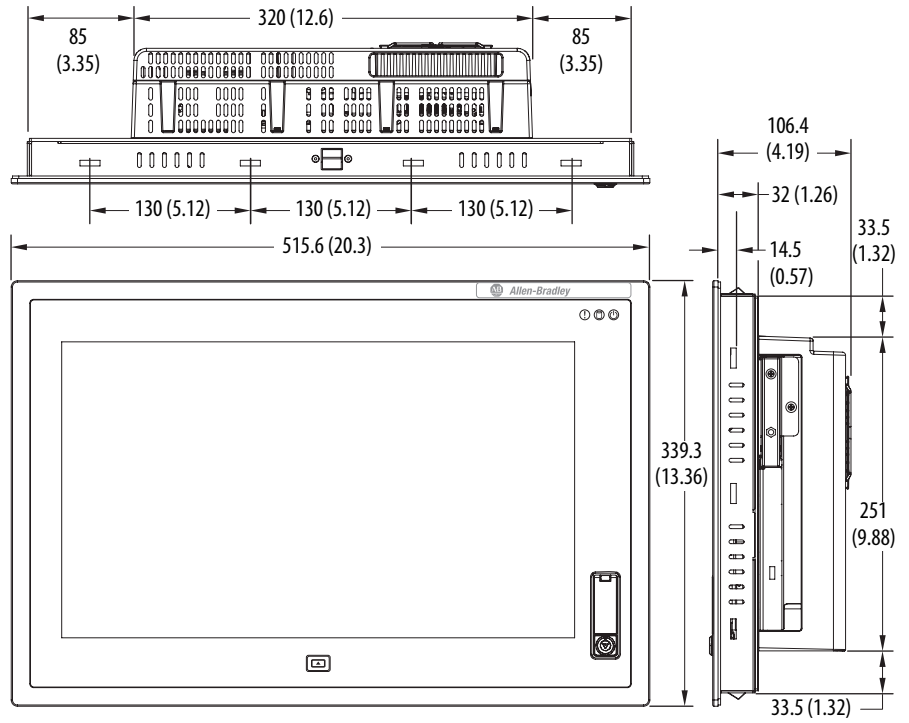


Figure 13 - 1900P (19-inch) Widescreen Display Computer



## Tools for Computer Installation

These tools are required for computer installation:

- #2 cross-head screwdriver
- Panel cutout tools (for panel mounting)
- Drill motor and drill bit (for wall, machine, and table mounting)
- Antistatic wriststrap

## Install the Computer

The computers support the following mounting options:

- Panel mount (display computer models)
- Wall, machine, table, and bookshelf mounts (non-display computer models)

### Panel Mounting Guidelines

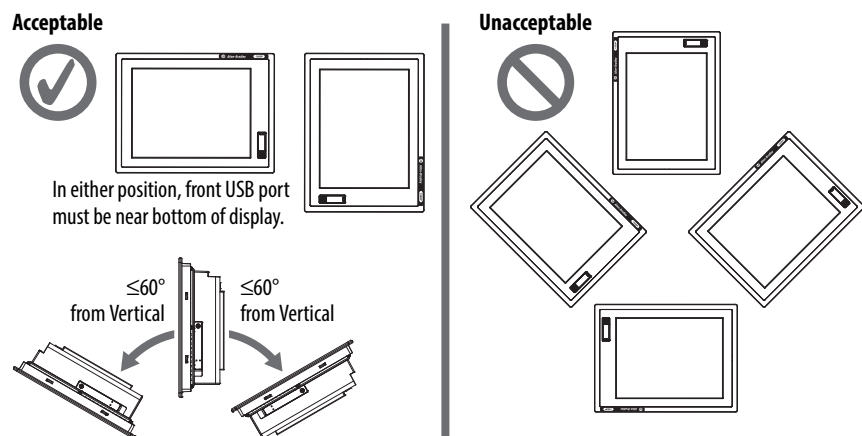
Observe these guidelines when installing the computer in a panel:

- Remove all electrical power from the panel before you make the cutout.
- Confirm that there is adequate space behind the panel. For specific information, refer to [Mounting Clearance Requirements](#) on [page 22](#).
- Cut supporting panels to specifications before installation. Take precautions so metal cuttings do not enter components already installed in panel.

Supporting panels must be at least 14 gauge for proper sealing against water and dust and to provide proper support. The mounting hardware supplied accommodates panel thickness between 1.5...5.5 mm (0.06...0.22 in.).

- Make sure the area around the panel cutout is clear.
- Certain restrictions apply when you mount a display computer in a panel. See [Figure 14](#) for details.

**Figure 14 - Acceptable and Unacceptable Mounting Positions for Display Computers**

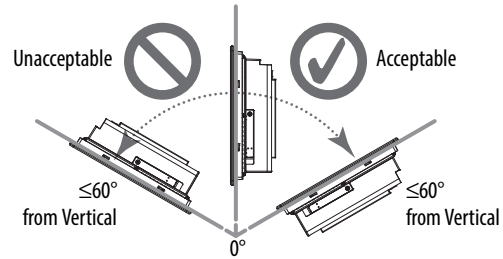


**ATTENTION:** Failure to follow these guidelines can result in personal injury or damage to the panel components.

- Display computers have mounting-assist clips on the top and bottom of the bezel. When the computer is placed into a panel cutout, the mounting-assist clips snap into place and hold the computer in position while you install the mounting clips.

Certain restrictions apply when you use mounting-assist clips. See [Figure 15](#) for details.

**Figure 15 - Acceptable and Unacceptable Mounting Positions for Using Assist Clips**



**ATTENTION:** The mounting-assist clips on display computers are no substitute for the mounting clips. You must install the mounting clips for safety, NEMA, UL Type, and IEC IP compliance.

Failure to follow these guidelines can result in personal injury or damage to the panel components.

## Panel Cutout Dimensions

A cutout template is shipped with each display computer model. 6181P and 6181X Integrated Display Industrial Computers Cutout Template, publication [6181P-DS002](#), is included with standard display models (4:3 and 5:4 aspect ratios). 6181P Integrated Display Industrial Computers Cutout Template, publication [6181P-DS003](#), is included with widescreen display models (16:9 aspect ratio).

The computers must be mounted to meet the panel cutout dimensions specified below.

| Model | Cutout Dimensions (H x W), approx    |                                    |
|-------|--------------------------------------|------------------------------------|
|       | Standard Models                      | Widescreen Models                  |
| 1200P | 254.0 x 324 mm (10.0 x 12.76 in.)    | —                                  |
| 1500P | 285.6 x 386.6 mm (11.24 x 15.22 in.) | 260.2 x 420 mm (10.24 x 16.54 in.) |
| 1700P | 329.5 x 424 mm (12.97 x 16.69 in.)   | —                                  |
| 1900P | 363.5 x 449.6 mm (14.31 x 17.7 in.)  | 321 x 493 mm (12.64 x 19.41 in.)   |

## Mount the Display Computer in a Panel

Mounting clips secure the display computer to the panel. The number of clips varies by model.

| Model            | Bezel           | Clips (qty.) | Cat. No.     | Description                     |
|------------------|-----------------|--------------|--------------|---------------------------------|
| 1200P Standard   | Aluminum        | 10           | 6189V-MCLPS3 | Replacement mounting clips (14) |
| 1500P Standard   |                 |              |              |                                 |
| 1500P Widescreen |                 | 12           |              |                                 |
| 1700P Standard   |                 | 10           |              |                                 |
| 1900P Standard   |                 | 14           |              |                                 |
| 1900P Widescreen |                 |              |              |                                 |
| 1500P            | Stainless steel | 10           |              |                                 |
| 1700P            |                 | 12           |              |                                 |
| 1900P            |                 | 14           |              |                                 |

Follow these steps to mount the computer in a panel.

1. Remove power from the panel.
2. Verify that the panel surface around the area to be cut is clean and free of debris.



**ATTENTION:** Take precautions so metal fragments do not enter components already installed in the panel to avoid personal injury or damage to the panel components.

3. Cut an opening in the panel by using the appropriate panel cutout dimensions.
4. Attach cables to the computer before installation if rear access to the computer is limited after installation.

For where to attach cables, see [Connect Peripherals on page 32](#).

AC power models: If necessary, remove the AC retention clip before you install the computers in a panel cutout. Reattach the clip after you install the computer.

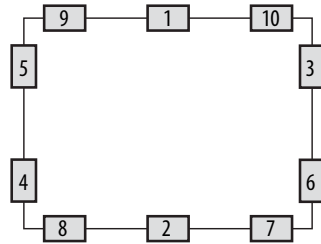
5. Make sure the sealing gasket is properly positioned on the computer.

This gasket forms a compression-type seal. Do not use sealing compounds.

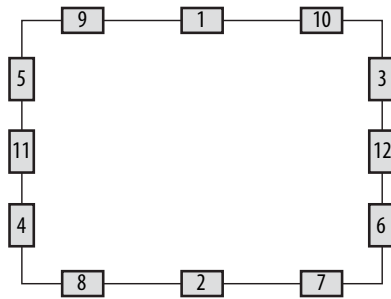
6. Place the computer in the panel cutout.
7. Slide the mounting clips into the holes on the top, bottom, and sides of the computer.

- Hand-tighten the mounting clips around the bezel by following the tighten sequence below.

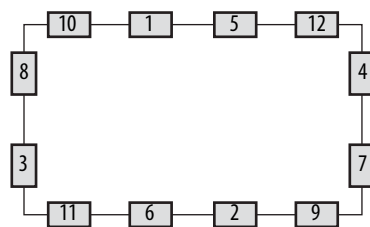
All Standard (4:3 and 5:4) Display Models with Aluminum Bezel except 1900P Display  
1500P Standard Display with Stainless Steel Bezel



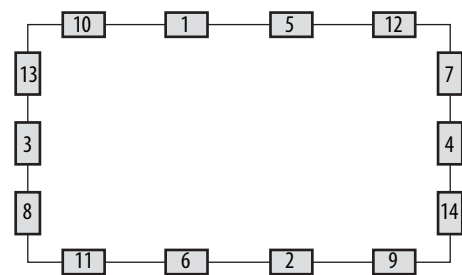
1700P Standard Display with Stainless Steel Bezel



1500P Widescreen (16:9) Display



All 1900P Standard and Widescreen Display Models



- Repeat this process at least three times until the clips are hand-tight and the gasket is compressed uniformly against the panel.
- Tighten the mounting clips to a torque of 1.35 N•m (12 lb•in) by following the torque sequence on the previous page. Do not overtighten.
- Repeat this process at least three times until the clips are properly torqued.

Make sure the gasket is compressed uniformly against the panel.



**ATTENTION:** Tighten the mounting clips to the specified torque to provide a proper seal and prevent damage to the product. Rockwell Automation assumes no responsibility for water or chemical damage to the computer or other equipment within the enclosure because of improper installation.

## Mount the Non-display Computer

Follow these steps to mount a non-display computer.

**IMPORTANT** Certain restrictions apply when you mount the computer to a wall or with a bookshelf mounting bracket. See [Figure 16](#) for details.

The bookshelf mounting bracket, catalog number 6189V-BOOKBRKT, must be ordered separately.

For horizontal mounting, see [page 22](#) for mounting clearance requirements.

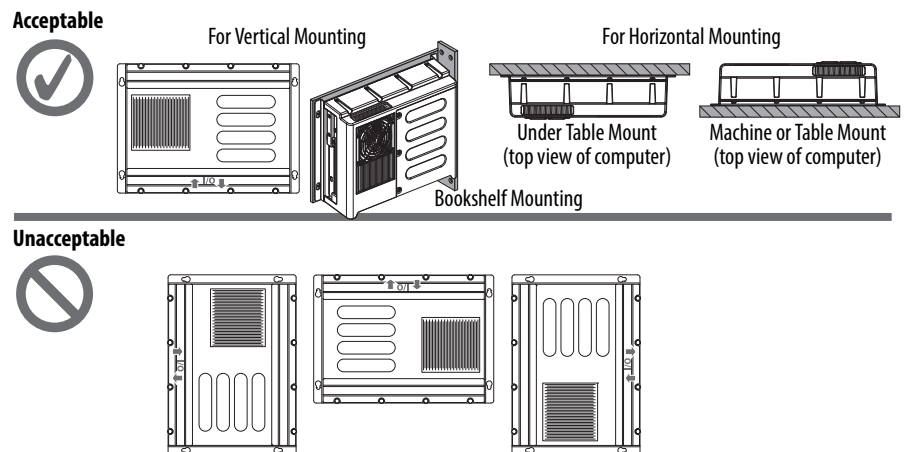
1. Verify that the power is disconnected.
2. Depending on your application, drill holes to accommodate M5-sized screws.

See [Figure 7 on page 23](#) for mounting hole locations and dimensions.

3. Mount the computer by using four M5 pan head screws.

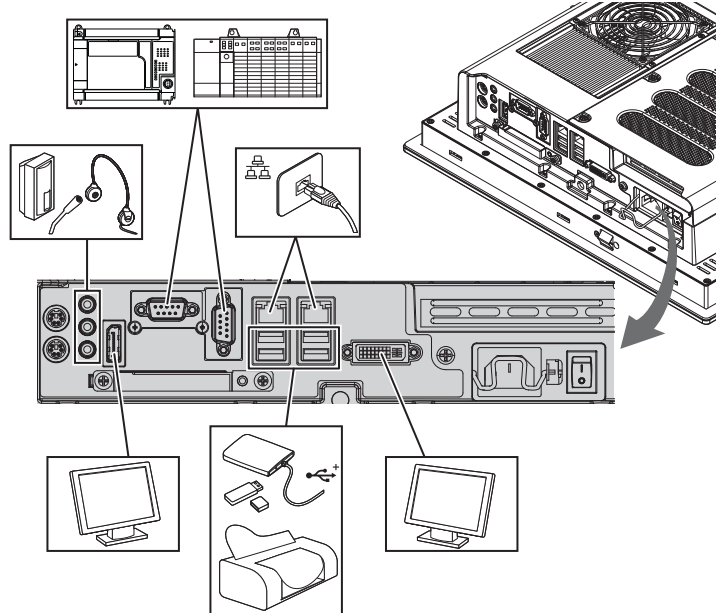
Tighten to a torque that is appropriate for the screw and material.

**Figure 16 - Acceptable and Unacceptable Mounting Positions for Non-display Computers**



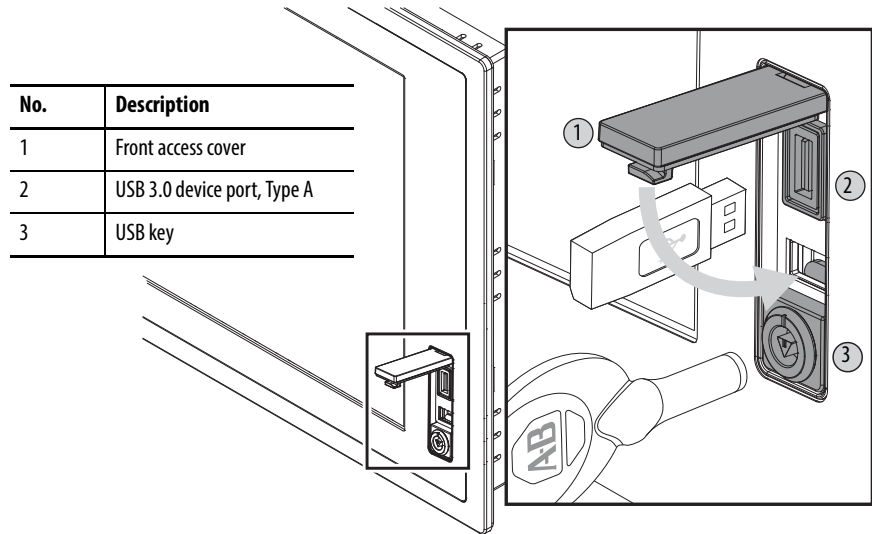
## Connect Peripherals

The following illustration shows the I/O port panel of the computers. Peripheral components compatible to each port are inside the callout figures.



Display computer models with aluminum bezels have USB ports on both the I/O port side panel and the front panel. Use these ports to connect various USB devices to the computer, such as an external drive.

All USB ports are enabled or disabled through settings in the UEFI set-up menu. See [USB Configuration on page 66](#) for more information.





## Connect Power

The computer connects to either a 100...240V AC or 18...32V DC power source, depending on the model.



**ATTENTION:** When you connect power to the computer for the first time, the following actions occur:

- The default UEFI setting automatically starts the computer after it is plugged into a power source.
- You must read and accept an End User Setup procedure for computers with a Windows operating system.

Do not disconnect power from the system until after the Windows Setup procedure is completed. If power is disconnected during this procedure, it can result in a corrupted system image.

Operate the computer in an industrial or control room environment, which uses some form of power isolation from the public low-voltage mains.



**ATTENTION:** Supply the computer circuit with its own disconnect. Use an uninterruptible power source (UPS) to help protect against unexpected power failure or power surges.

Always shut down the Windows operating system before you disconnect power to the computer to minimize performance degradation and operating system failures.

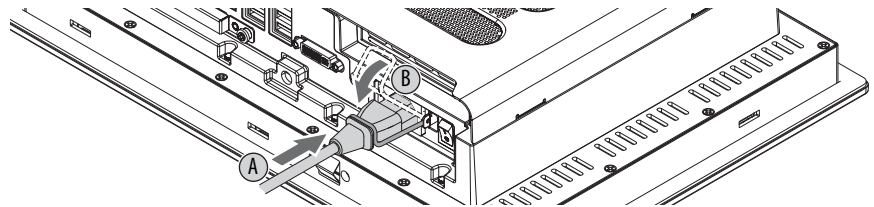
## Connect AC Power

A grounded, 3-prong IEC60320-C13 power cord provides power to the computer. The power supply input accepts 100...240V AC and is autoranging.

**TIP** If you use an alternate IEC60320 cord, make sure the female end of the cord is sized appropriately for the retention clip.

Follow these steps to connect the computer to an AC power source.

1. Connect the power cord to the AC power input (A).
2. Secure the power cord in place with the retention clip (B).



3. Connect the AC power cord to a power source.



**SHOCK HAZARD:** Connect the AC power cord to a power source with an earth ground. Failure to follow this warning can result in electrical shock.

4. Apply 100...240V AC power to the computer.

## Connect DC Power

Computers with catalog numbers that end in DC have a DC input terminal block to connect to a 18...32V DC power source.

The functional ground screw must be grounded on DC power models for EMC regulatory compliance. DC power models support operation from either a SELV or PELV power source. The DC common (DC-) can be connected together to the functional ground screw to support some SELV cases where grounding at the computer is required by the end user.

The power supply is internally protected against reverse polarity.



**ATTENTION:** Use a SELV isolated and ungrounded power supply as input power to the computer. This power source provides protection so that under normal and single fault conditions, the voltage between the conductors and Functional Earth/Protective Earth does not exceed a safe value.

Follow these steps to connect the computer to a DC power source.

**IMPORTANT** A functional ground screw connection is required for EMC compliance.

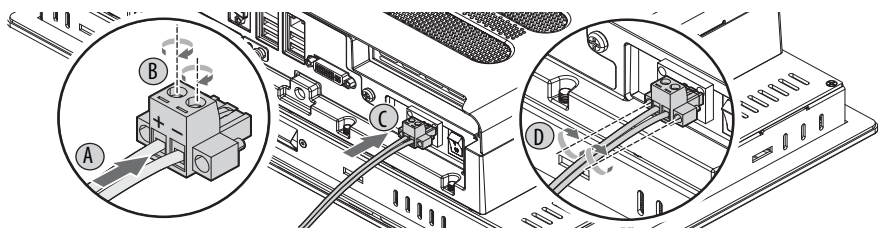
1. Turn off the main power switch or breaker.
2. Verify that the DC power wires meet these requirements:
  - Material: Stranded copper
  - Wire gauge: 0.326...3.31 mm<sup>2</sup> (22...12 AWG)
3. Insert each DC power wire into the correct terminal-block on the DC power adapter (A).
4. Secure the DC power wires to the terminal-block screws of the power adapter (B).
5. Connect the DC power adapter to the power supply terminal block (C).
6. Secure the DC power adapter into place with the terminal-block screws (D).

Torque the terminal screws to 0.687 N•m (6.1 lb•in).

7. Connect the computer to earth ground by using a 1.5 mm<sup>2</sup> (16 AWG) or larger external wire.

Use a ground wire with an insulation color that is approved by local inspection authority.

8. Apply 18...32V DC power to the computer.



## Functional Ground Screw

Functional ground screw requirement depends on the power source.

If you use the functional ground screw, connect the computer to earth ground by using a 1.5 mm<sup>2</sup> (16 AWG) or larger external wire. Use a ground wire with an insulation color that is approved by local inspection authority.

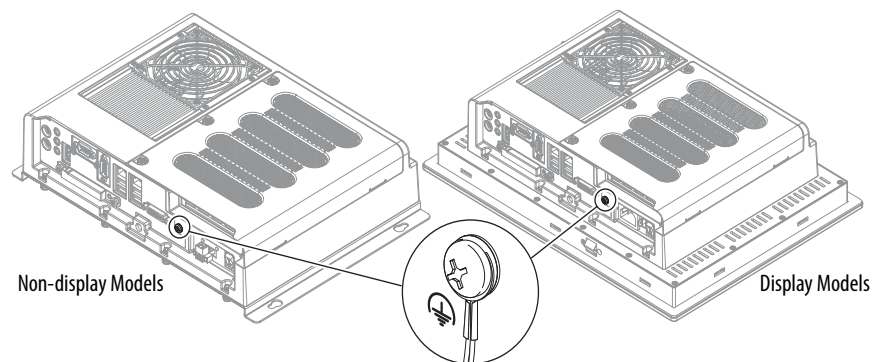
## AC Power Models

The pre-installed functional ground screw is not required for safety or regulatory compliance. AC power models are already grounded through the AC power cord. If a supplemental ground is required, use the functional ground screw in the I/O port panel of the computer.

## DC Power Models

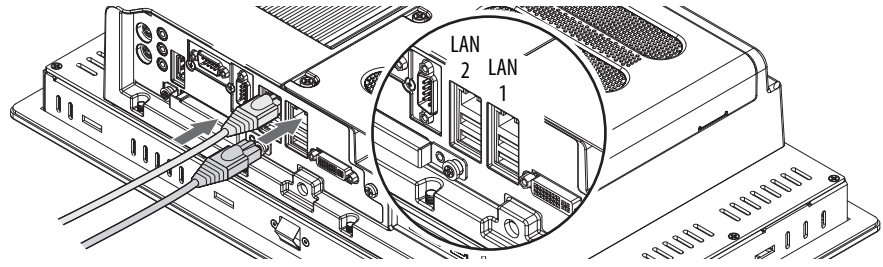
The pre-installed functional ground screw is not required for safety but is required for EMC regulatory compliance.

**Figure 17 - Functional Ground Screw Location**



## Connect to a Network

The computers have two 1 Gb LAN ports that connect to an EtherNet/IP network by using CAT5 or better twisted-pair Ethernet cabling with RJ45 connectors.



---

**IMPORTANT** To help prevent performance degradation of Ethernet communication, do not subject the computer or cables to extreme radiation or conducted high-frequency noise.

In industrial environments, proper cable routing and power conditioning is required for reliable Ethernet communication. We recommend that you route all Ethernet cabling through dedicated metal conduits. For improved reliability, install ferrite bead filters at the cable ends.

---

The LAN 1 port supports AMT functionality for computers with the Intel i7 processor (Tier 3 models) that are configured for AMT.

See [AMT Configuration on page 71](#) for more information.

The LAN 2 port supports VMWARE ESXi communication.

---

**IMPORTANT** When prompted during the set-up process, We recommend that you select the Public Network option for the most secure network connection. However, you are ultimately responsible for what network security setting is the most appropriate one.

---

## Operate the Computer

| Topic                         | Page |
|-------------------------------|------|
| Operating Guidelines          | 37   |
| Touchscreen Precautions       | 38   |
| Start the Computer            | 38   |
| Restart the Computer          | 39   |
| Shut Down the Computer        | 39   |
| Adjust the Display Brightness | 40   |

### Operating Guidelines

Follow these operating guidelines for your computer:

- Operator access is limited to the front of the computer, which includes the display and the touchscreen (if available).

---

**IMPORTANT** Access to components behind the panel where the computer is installed and the front USB port (if available) is restricted to authorized and properly trained personnel.

---

- When mounted in an enclosure, keep the enclosure door closed during operation so dust and other airborne contamination do not infiltrate the computer. Open the door only for routine maintenance.




---

**SHOCK HAZARD:** Do not operate the computer with the covers removed. An electrical shock hazard exists. All covers are required to maintain EMI shield.

---

- Always use the proper power down procedures as required by your operating system, such as the Shut Down command in the Microsoft Windows operating system.
- After shutting down the computer, do not apply power again until shutdown is complete.

For computers with a HDD, the HDD must come to a complete stop, which can take up to 30 seconds after shutdown is initiated.

## Touchscreen Precautions



**WARNING:** If the LCD screen darkens or if the backlight is not functioning properly, the screen may be difficult to read and use of this screen could result in a potentially hazardous outcome. Do not use the LCD touch screen under these circumstances.

The design of the system must take into account the possibility of the LCD screen or LCD touch screen losing functionality and unable to be used to maintain or change control of the system. The touch screen shall not be the single point of control of critical functions and is not intended to replace an E-Stop.

Design of the system should follow all applicable code and good engineering practice. Factors to consider include the following:

- The possibility of an unreadable LCD screen
- The possibility of an inoperable touch screen
- Unexpected communication errors or delays
- Operator error in the control of the system
- Proper use of E-Stops and other safety practices

The user shall provide means to achieve a safe state during anomalies and ensure the system has adequate redundancy for critical functions.

Failure to follow these instructions can result in death, serious injury, or equipment damage.

---

## Start the Computer

Follow these steps to start the computer.

---

**IMPORTANT** The following steps apply to when the computer must be manually started. See [Connect Power on page 33](#) for when power is applied to the computer for the first time.

---

1. Make sure any connected components with separate power supplies (such as an external display) are turned on first.
2. Make sure all necessary peripheral devices are connected to the corresponding I/O ports on the computer.
3. Install power to the power input of the computer.

AC powered models: See [Connect AC Power on page 33](#) for how to install the AC power cord into the AC power input on the computer.

DC powered models: See [DC Power Models on page 35](#) for how to install DC power to the DC power input on the computer.

4. Apply power to the computer.

AC powered models: Plug the AC power cord into a power source or wall outlet.



**SHOCK HAZARD:** Connect the AC power cord to a power source with an earth ground. Failure to follow this warning can result in electrical shock.

DC powered models: Apply 18...32V DC power to the computer.

5. Press the computer's power switch.

See [Hardware Features on page 12](#) for power switch location.

The computer performs certain actions when it is started or reset. See [Restart the Computer on page 39](#) for what is done.

If your system does not start or you notice other anomalies, refer to [Troubleshoot the System](#) starting on [page 87](#).

## Restart the Computer

Use any of the following methods to restart your computer.

- From the Start menu, choose Restart.
- Press Ctrl+Alt+Delete on an attached keyboard and click Restart.
- Use AMT commands (only for Tier 3 computers; see [page 10](#) to see if your computer qualifies and [page 71](#) for more about AMT configuration).

During a restart, the computer does the following:

- Clears the RAM.
- Starts the POST.
- Initializes peripheral devices such as drives and printers.
- Loads the operating system.

Use the computer display to view the progress of the POST, the initialization of accessory devices, and the start-up dialogs for the operating system that is installed.

## Shut Down the Computer

Use either of the following methods to shut down the computer.

| Method       | Actions   |
|--------------|---|
| Windows OS   | With an attached mouse and keyboard, do one of the following. <ul style="list-style-type: none"> <li>• Press Ctrl+Alt+Delete and click Shut Down.</li> <li>• From the Start menu, click or choose Shut Down from the pull-down menu.</li> </ul> |
| Power switch | Momentarily press the power switch to shut down the computer. See <a href="#">Hardware Features on page 12</a> for the power switch location.   |

## Adjust the Display Brightness

Display computers have an adjustable display brightness setting that can be adjusted in the BIOS/UEFI or in the Windows operating system. The display brightness default setting is 70%.

See [Chipset on page 72](#) for how to adjust the brightness through the BIOS/UEFI.

---

**IMPORTANT** Increasing the brightness from the default setting reduces the life of the LED backlight, particularly at high temperatures.

---



## Replace Components

| Topic                               | Page |
|-------------------------------------|------|
| Accessories and Replacement Parts   | 41   |
| Voltage Precautions                 | 41   |
| Electrostatic Discharge Precautions | 42   |
| Pre-configuration                   | 42   |
| Post-configuration                  | 43   |
| Required Tools                      | 43   |
| Remove the Cover                    | 43   |
| Reinstall the Cover                 | 44   |
| CompactFlash Card                   | 44   |
| Drive Precautions                   | 45   |
| Replace a Drive                     | 46   |
| Replace or Add Memory Modules       | 47   |
| Replace the RTC Battery             | 49   |
| Replace the Power Supply Unit       | 51   |

### Accessories and Replacement Parts

You can view a list of accessories and replacement parts at <http://ab.rockwellautomation.com/Computers/Integrated-Display-Computers/Bulletin-6181#selection>.

Review the specifications of a new component before you install it to verify that it is compatible with the computer. Record the model, serial number, and any other pertinent information of new components for future reference.

---

**IMPORTANT** We recommend that you use only Allen-Bradley® approved accessories and replacement parts.

---

### Voltage Precautions

The computers contain line voltages. Disconnect all power to the computer before you install or remove components.



**SHOCK HAZARD:** Disconnect all power to the computer before you remove components.

Failure to disconnect power can result in severe electrical shock to an individual or electrostatic discharge (ESD) damage to the computer and components.

---

## Electrostatic Discharge Precautions



**ATTENTION:** Electrostatic discharge (ESD) can damage static-sensitive devices or microcircuitry:

- Disconnect all power before you work on the computer as detailed in [Voltage Precautions on page 41](#).
  - Observe proper packaging and grounding techniques to help prevent damage.
- 

Follow these ESD precautions:

- Transport the computer and replacement parts in static-safe containers, such as conductive tubes, bags, or boxes.
- Keep electrostatic-sensitive parts in their containers until they arrive at the designated static-free work area.
- Cover the designated work area with approved static-dissipating material:
  - Use an antistatic wriststrap connected to the work surface.
  - Use properly grounded tools and equipment.
- Keep the designated work area free of nonconductive materials, such as ordinary plastic assembly aids and foam packing.
- Avoid touching pins, leads, or circuitry.
- Always hold components with a printed circuit board (PCB) by its edges and place it with the assembly side down.

## Pre-configuration

---

### **IMPORTANT**

Before you install hardware or perform maintenance procedures that require access to internal components, we recommend that you first back up all computer data to avoid loss.

---



**ATTENTION:** Make sure to read and understand all installation and removal procedures before you begin configuring the computer hardware.

---

Follow these steps before you remove the cover or you replace a hardware component.

1. Shut down the computer and all peripherals that are connected to it.
2. Disconnect all cables from power outlets to avoid exposure to high energy levels.  
If necessary, label each cable to expedite reassembly.
3. Disconnect telecommunication cables to avoid exposure to a shock hazard from ring voltages.

## Post-configuration

Follow these steps after you install or remove a hardware component.

1. Make sure all components are installed according to instructions.
2. Make sure that no tools or loose parts are left inside the computer.
3. Reinstall any expansion boards, peripherals, and system cables that were previously removed.
4. Reinstall the cover according to the instructions on [page 44](#).
5. Reconnect all external cables and power to the computer.
6. Press the power switch to start the computer.

## Required Tools

The following tools are required for component replacement:

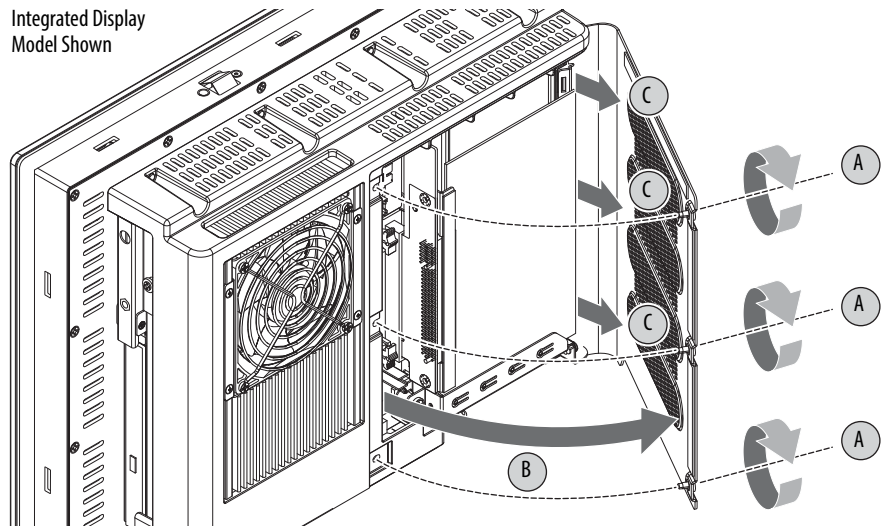
- #2 cross-head screwdriver
- Antistatic wrist strap
- Side cutters (to cut cable ties, if necessary)

## Remove the Cover

To install, replace, or upgrade internal computer components, you must first remove the cover.

Follow these steps to remove the rear cover (a display computer is shown).

1. Follow the steps for [Pre-configuration on page 42](#).
2. Loosen the three screws that secure the rear cover (A).
3. Open the cover (B) and detach it from the chassis (C).

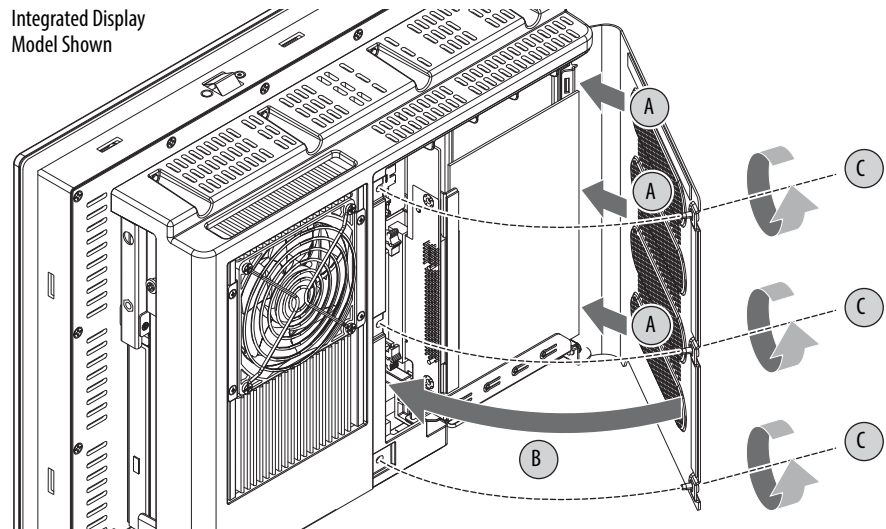


4. After you install, replace, or upgrade internal computer components, reinstall the cover as detailed in [Reinstall the Cover on page 44](#).

## Reinstall the Cover

Follow these steps to reinstall the rear cover (a display computer is shown).

1. Follow steps 1...3 for [Post-configuration on page 43](#).
2. Reattach the rear cover to the chassis (1).
3. Close the cover (2).
4. Tighten the three screws to secure the rear cover (3).



5. Follow steps 4 and 5 for [Post-configuration on page 43](#).

## CompactFlash Card

The computers have a CompactFlash (CF) Type II card slot for loading CF cards on the I/O port panel below the serial ports. See [Hardware Features](#) starting on [page 12](#) for the CF card slot location.

**IMPORTANT** The CF card slot is a bootable slot for DOS and Linux operating systems but not for Windows operating systems.

You can insert or remove a FAT32 formatted CF card from this slot while the computer is on. For a NTFS formatted CF card, use the Windows 'Safely Remove/Eject Media' process.

Follow these steps to load a CF card.

1. Loosen the two screws that secure the CF card slot cover.
2. Remove the CF card slot cover.
3. Insert the CF card into the slot until it is firmly seated.



**ATTENTION:** When properly seated, more than 80% of the CF card easily inserts into the slot before you encounter resistance. If you encounter resistance before then, remove the card, rotate it 180°, and reinsert.

Do not force the card into the slot. Forcing the card into the slot can damage the connector pins.

4. Reattach the CF card slot cover.
5. Tighten the two screws to secure the slot cover.

## Drive Precautions

Follow these precautions when you work with a drive.

---

**IMPORTANT** Back up or clone your computer before you replace a drive.  
See [AMI Rescue on page 80](#) for more information on how to back up your system image.

---

- Do not touch internal components.
- Always handle the drive by its frame.
- Do not remove or install a drive with the power on except in circumstances allowed by the operating system.
- Store the drive in an antistatic bag when it is not installed.



**SHOCK HAZARD:** Electrostatic discharge (ESD) can damage the computer and components. Read and follow [Electrostatic Discharge Precautions on page 42](#) before you remove a drive.

Failure to follow proper safety precautions can result in severe electrical shock to an individual or ESD damage to the computer and its components.

---



**ATTENTION:** Mechanical shock can damage a drive. Do not drop or bump the drive.

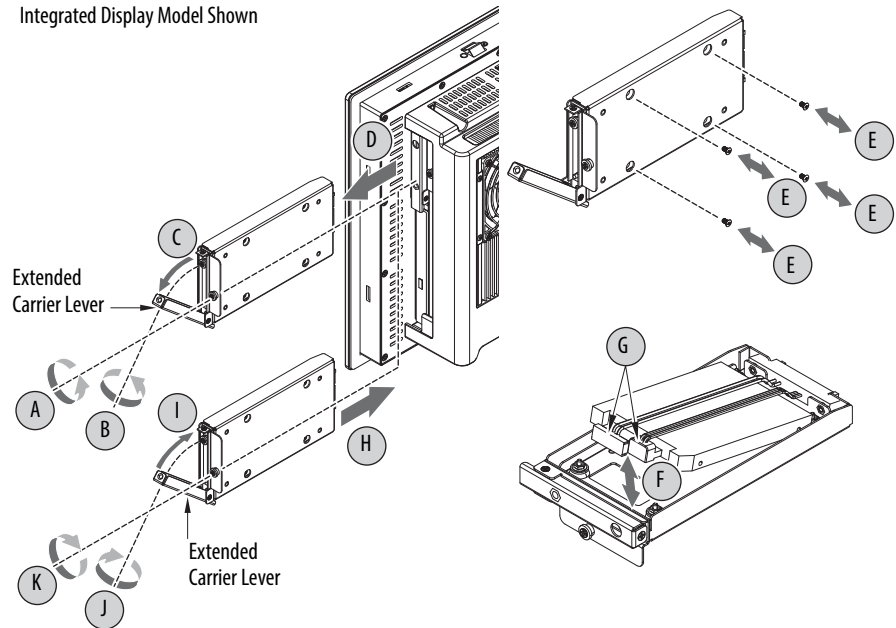
---

## Replace a Drive

Follow these steps to replace a drive (HDD or SSD), which is on the side of the computer.

1. Read and follow [Drive Precautions on page 45](#) before you perform any drive removal.
2. Follow the steps for [Pre-configuration on page 42](#).
3. Remove the one screw that secures the drive assembly (A).

Integrated Display Model Shown

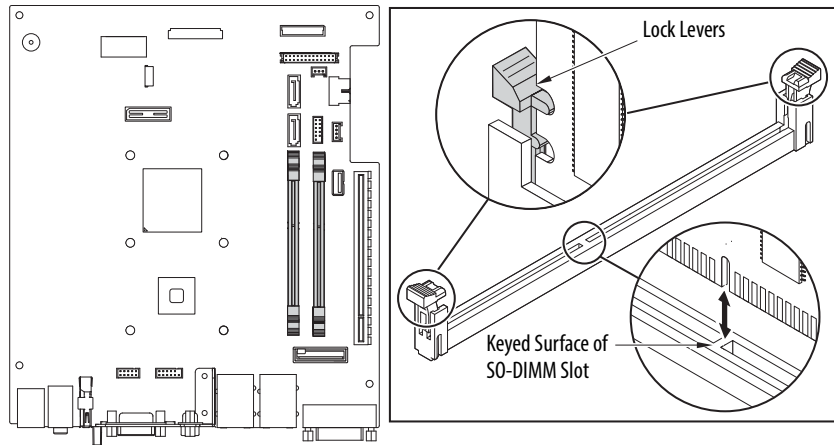


4. Loosen the screw to release the carrier lever (B).
5. Extend the carrier lever (C), then use it to slide the assembly out of the drive bay (D).
6. Remove the four screws that secure the drive to its carrier (E).
7. Lift the cable connector end of the drive (F) and disconnect the power and data cables (G).
8. Remove the drive from its carrier.
9. Hold the new drive by its edge and remove it from its protective packaging.
10. Align the new drive on the carrier (F).
11. Connect the power and data cables to the drive (G).
12. Secure the new drive to the carrier with the four screws (E).  
Torque the screws to 0.452 N•m (4 lb•in).
13. Use the extended carrier lever to slide the assembly into the drive bay (H).
14. Retract the carrier lever (I) and tighten its screw to lock in place (J).
15. Secure the drive assembly with the one screw (K).
16. Follow the steps for [Post-configuration on page 43](#).

## Replace or Add Memory Modules

The computers have two dual-channel DDR3 SO-DIMM slots that support up to 16 GB maximum system memory.

**Figure 18 - Memory Module Slots and Module Alignment**



**IMPORTANT** Computer performance is optimized with both memory module slots populated.

All 6181P computers ship with a dual memory module configuration.

## Memory Configuration Guidelines

Follow these guidelines when you replace or add memory to the computers:

- Use only standard unbuffered memory modules that conform to both PC3-10600 and SPD compliance industry standards.
- Use only DDR3 type memory modules.
- Use only memory modules with gold-plated contacts.
- Always handle a memory module by its edges.

**IMPORTANT** We recommend that you use only Allen-Bradley approved memory modules. Refer to <http://ab.rockwellautomation.com/Computers> for qualified replacement parts and accessories.

## Replace or Add a Memory Module

Follow these steps to replace or add a memory module.

---

**IMPORTANT** Use an antistatic wriststrap connected to the work surface, and properly grounded tools and equipment.

---

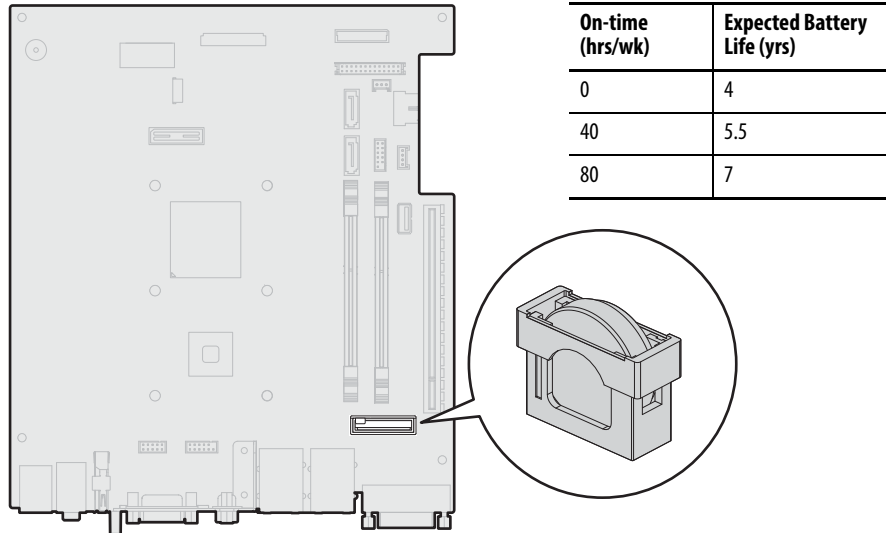
1. Follow the steps for [Pre-configuration on page 42](#).
2. Remove the computer cover as detailed in [Remove the Cover on page 43](#).
  - TIP** To install additional memory, proceed to [step 5](#) of this section.
3. Locate the memory module that you want to replace. See [Internal Components on page 14](#) for memory location on the motherboard.
4. Remove the selected memory module.
  - a. Use your thumbs or fingers to push open the lock levers, which releases the memory module from its slot for easy removal. See [Figure 18 on page 47](#).
  - b. Gently pull out the memory module to remove it from its slot.
  - c. Place the memory module on a static-dissipating work surface or inside an antistatic bag.
5. Install the new memory module.
  - a. Hold the memory module by its edges as you remove it from its antistatic bag.
  - b. Orient the module so the notch on its bottom edge aligns with the keyed surface of the SO-DIMM slot. See [Figure 18 on page 47](#).
    - TIP** The keyed surface is off center to assist the correct alignment.
  - c. Press the module fully into the slot to engage the lock levers. See [Figure 18 on page 47](#).
6. Follow the steps for [Post-configuration on page 43](#).



## Replace the RTC Battery

The computers use nonvolatile memory that requires a real-time clock (RTC) lithium battery to retain system information when power is removed. The RTC battery is next to the SO-DIMM1 slot.

This battery is intended to be replaced during the life of the computer. The battery life depends on the amount of time the computer is on, or on-time.



If the computer does not retain the correct time and date, replace the battery.



**ATTENTION:** A risk of fire and chemical burn exists if the battery is not handled properly:

- Do not disassemble, crush, puncture, or short external contacts.
- Do not expose the battery to temperatures higher than the rated temperature ranges on [page 21](#).
- Do not dispose of a used battery in water or fire.

For safety information on handling lithium batteries, see Guidelines for Handling Lithium Batteries, publication [AG-5.4](#).

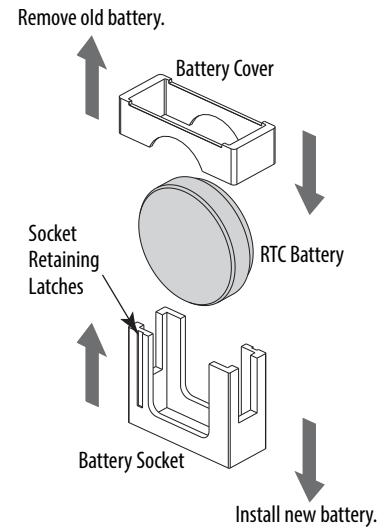
Follow these steps to replace the RTC battery.

**IMPORTANT** Depending on your model, replace with a similar CR2450-type coin battery rated at least 0 to 85 °C (32 to 185 °F) operating temperature range.

1. Follow the steps for [Pre-configuration on page 42](#).
2. Remove the computer cover as detailed in [Remove the Cover on page 43](#).

3. If necessary, remove any accessory boards or cables that prevent access to the RTC battery socket.
4. Remove the old battery.
  - a. Pull the battery cover straight out of the battery socket.
  - b. Pull the old battery from its socket.
5. Install the new battery.
  - a. Insert the new battery with the positive polarity (+) side nearest the SO-DIMM memory slots.

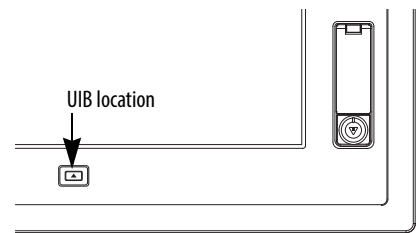
Verify that the battery is seated completely.



**TIP** The socket retaining latches allow only one way for the battery to be installed.

- b. Reinstall the battery cover.
6. Follow the steps for [Post-configuration on page 43](#).
7. During POST, press F2 on an attached keyboard or press the UIB<sup>(1)</sup> to access the UEFI setup and reconfigure settings.

For more information on UEFI settings, see [page 55](#).



**IMPORTANT** If you replace the battery, then all UEFI settings return to their default settings. UEFI settings other than default must be reconfigured after you replace the battery.



This computer contains a sealed lithium battery that could need replacing during the life of the computer.  
At the end of its life, collect the battery contained in this computer separately from any unsorted municipal waste.

(1) The UIB is only on the front of display computers with aluminum bezels.

## Replace the Power Supply Unit

Follow these steps to replace the power supply unit (PSU).

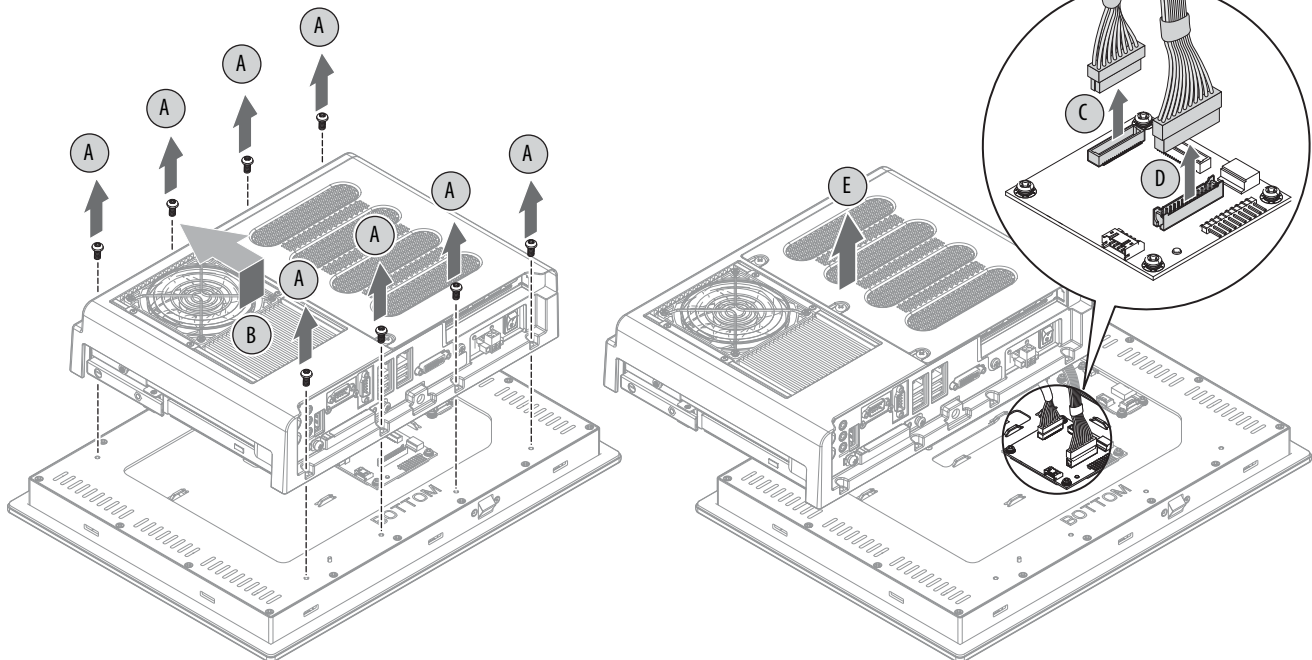
**IMPORTANT** Use an antistatic wriststrap that is connected to the work surface and properly grounded tools and equipment when you handle internal computer components.

1. Follow the steps for [Pre-configuration on page 42](#).
2. Place the computer on a flat, steady surface with the rear cover facing upward.
3. Remove the eight screws that secure the computer to the display panel (A).
4. Lift and slide the computer forward so you can unplug the display cables (B).
5. Disconnect the eDP signal (C) and panel (D) cables from the panel adapter board.

**IMPORTANT** For display computers with aluminum bezels, do not disconnect the USB 3.0 cable between the motherboard and front bezel USB port. If necessary, cut cable ties so the computer can be 'hinged' into a safe work position while the USB 3.0 cable remains connected. The USB 3.0 cable is fragile so keep it connected to avoid any possible damage. Replacement cable ties are supplied with the replacement power supply.

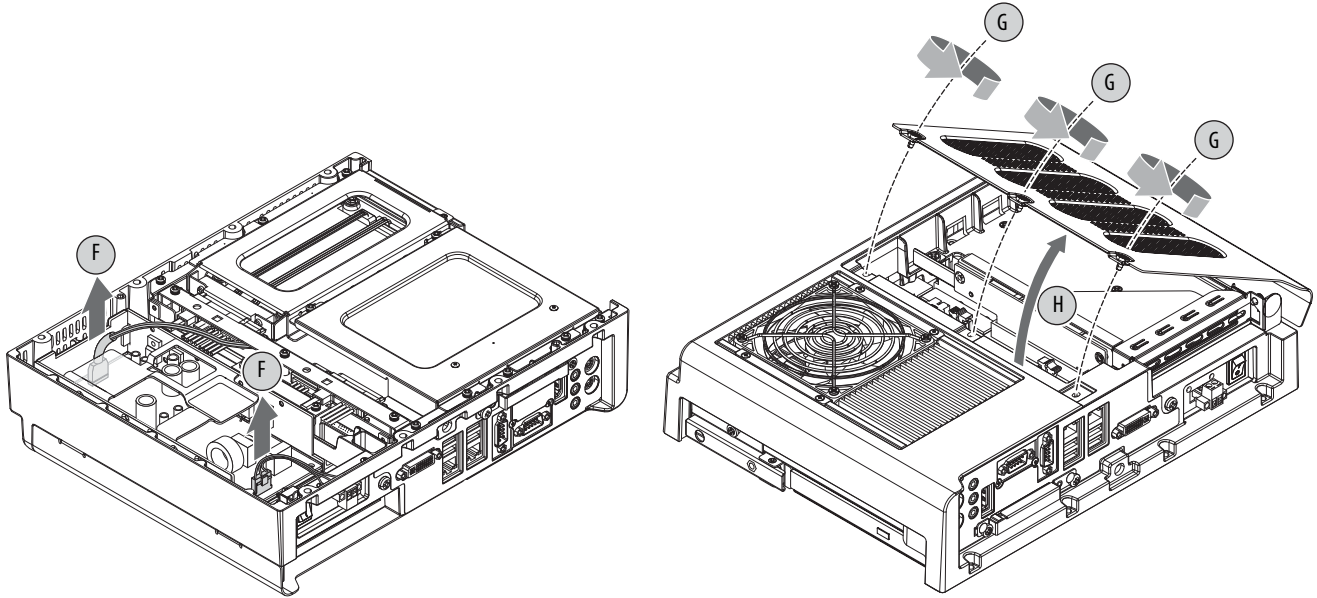
6. Lift the computer off the display panel (E).

DC Powered Integrated Display Model Shown

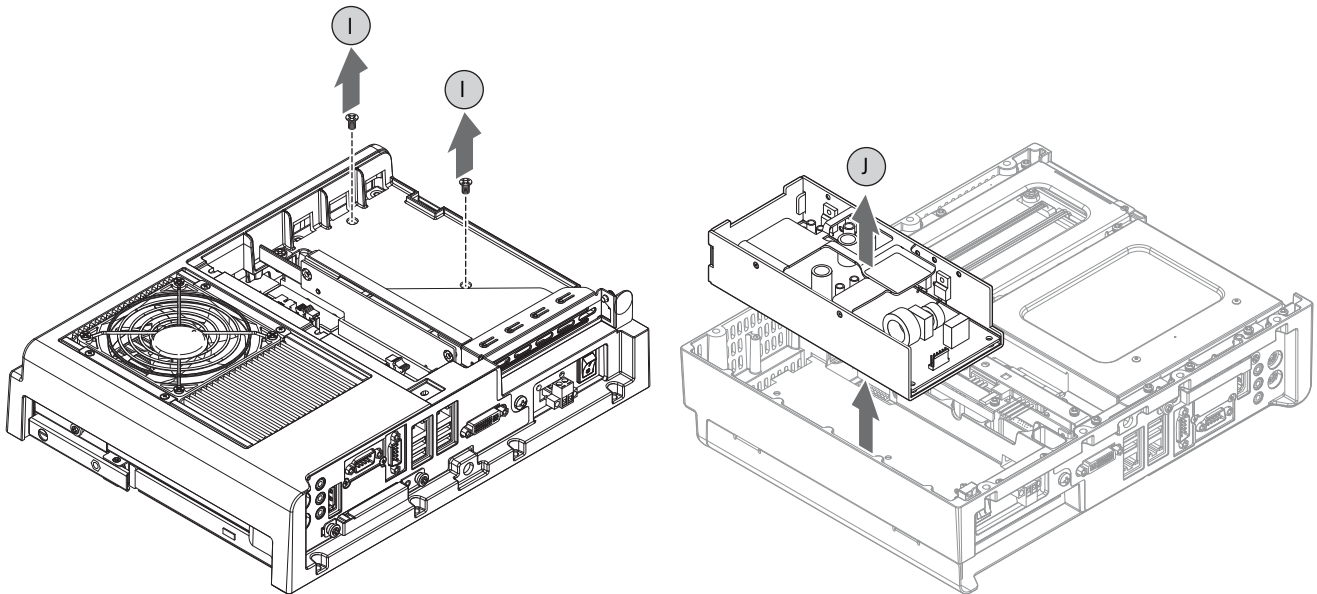


7. Turn over the computer to access the PSU.
8. Remove the screws that secure the two power connectors (F) from the PSU.
9. Disconnect the two power connectors.

10. Turn over the computer to access the rear cover.
11. Remove the rear cover.
  - a. Loosen the three screws that secure the rear cover (G).
  - b. Open the cover and detach it from the chassis (H).



12. Remove the two screws (I) that secure the PSU to the chassis.
13. Turn over the computer to access the PSU.
14. Remove the PSU (J).



15. Install the new PSU in the reverse order of the removal steps.
  - a. Torque the two screws to 1.4 N•m (12 lb•in) to secure the new PSU.
  - b. Before you reinstall the computer to the display unit, verify that the following are properly connected:
    - the two PSU power connectors and their screws
    - the eDP signal and panel cables
  - c. Remove and replace any cut cable ties.
16. Follow the steps for [Post-configuration on page 43](#).

**Notes:**

## Set Up the UEFI Utility

| Topic                     | Page |
|---------------------------|------|
| Set-up Utility Overview   | 55   |
| Access the Set-up Utility | 56   |
| Set-up Screen Overview    | 56   |
| Firmware Update           | 57   |
| Firmware Configuration    | 58   |
| Diagnostics               | 78   |
| AMI Rescue                | 80   |
| Hardware History          | 84   |
| Exit                      | 85   |

### Set-up Utility Overview

The set-up utility is a hardware configuration program built into the universal extensible firmware interface (UEFI). In this chapter, UEFI replaces Basic Input/Output System (BIOS) to describe the system firmware except where BIOS is specifically used, such as on a graphical interface.

The UEFI is already configured and optimized so there is no need to run this utility. However, you can run the set-up utility to do the following:

- Change the system configuration.
- Change the UEFI setup when a configuration error is detected by the system.
- Redefine communication ports to prevent any conflicts.
- Read the current amount of system memory.
- Change the boot drive order.
- Set or change the password or make other changes to the security settings.
- Upgrade the system firmware.
- Run the diagnostic utility to determine the cause of system malfunction.
- Restore or back up the operating system.

## Access the Set-up Utility

Follow these steps to access the set-up utility in your computer.

1. Start your computer.
2. During POST, you have two selections to access the set-up utility.

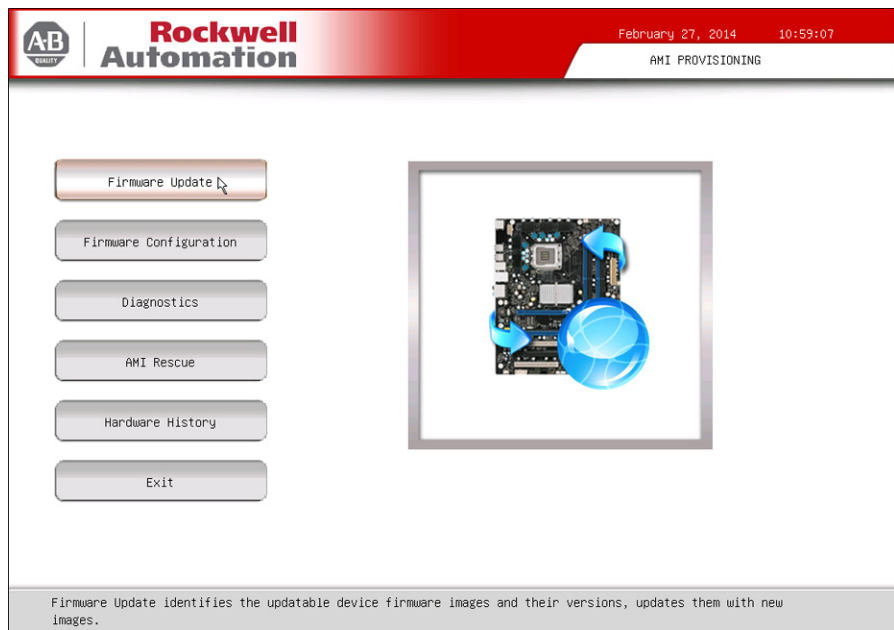
| Press   | Result   |
|---|--|
| F2 or<br>UIB on front of display <sup>(1)</sup> | Accesses a graphical interface of set-up environment.<br><b>IMPORTANT:</b> Screen shots in this chapter are from the UEFI graphical interface. |
| DEL (delete)                                    | Accesses a text mode set-up environment.   |

(1) UIB is only available on display computers with aluminum bezels.

## Set-up Screen Overview

The set-up screen is the main screen for the UEFI graphical interface. On the left are six menu buttons that are stacked vertically. Each menu button provides access to information, commands, or configurable options for the following topics:

- [Firmware Update](#)
- [Firmware Configuration](#)
- [Diagnostics](#)
- [AMI Rescue](#)
- [Hardware History](#)
- [Exit](#)

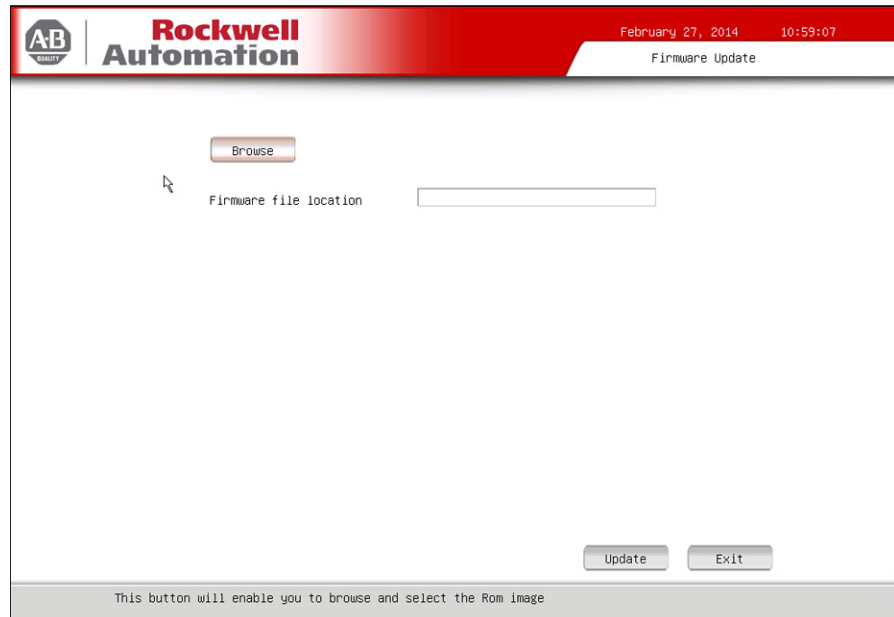


**TIP** The UEFI graphical interface can be driven with either the integrated touchscreen or a keyboard and mouse. An On Screen Keyboard (OSK) pops up automatically when a user enters an entry field.



## Firmware Update

You can update your system firmware from the Firmware Update menu.



| Parameter              | Description  |
|------------------------|--|
| Browse                 | Click to navigate to the firmware file saved onto a media. |
| Firmware file location | Select or type the file name for the firmware file.        |
| Update                 | Click to initialize the update process.                    |
| Exit                   | Click to exit the set-up utility.                          |

Follow these steps to update the system firmware.

1. Click the Firmware Update menu.  
The Firmware Update screen appears.
2. Click Browse to locate the firmware file.

---

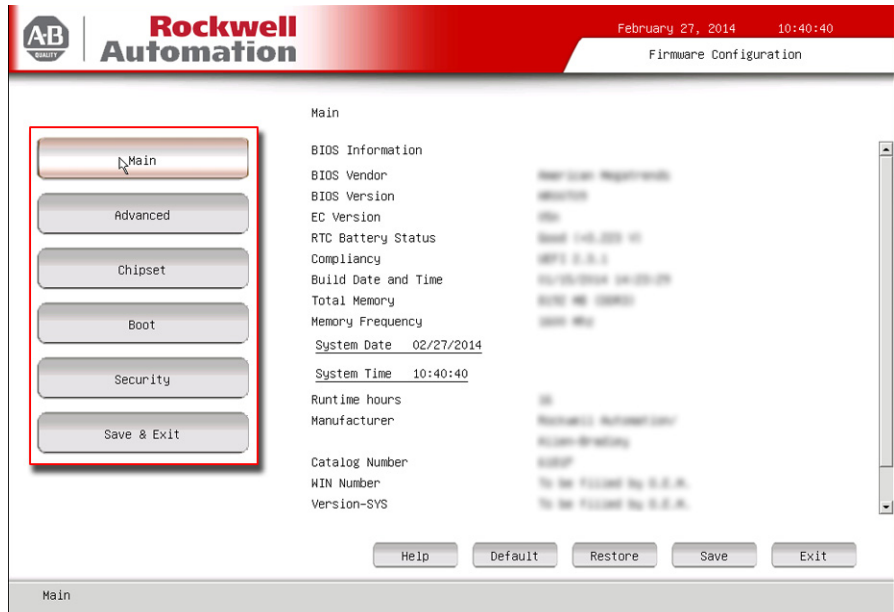
**IMPORTANT** The USB mass storage device that contains the firmware file must be FAT, FAT16, or FAT32 formatted to be recognized.  
See <http://www.rockwellautomation.com/compatibility/> to check for revisions and to download firmware files.

---

3. Click Update.

## Firmware Configuration

You can view and modify the various system parameters from the Firmware Configuration menu. It features several menu buttons on the left side of the screen.



| Menu        | Description  |
|-------------|--|
| Main        | Use this menu to view general computer information and for basic system configuration.   |
| Advanced    | Use this menu to configure information for the PXE, PCI, ACPI, processor, SATA, USB, power, video graphics, super IO, hardware monitor, and AMT. |
| Chipset     | Use this menu to configure system chipset information.   |
| Boot        | Use this menu to configure boot device priority.   |
| Security    | Use this menu to set or change user and administrator passwords.   |
| Save & Exit | Saves changes and reset, discards changes and reset, or restore defaults.  |

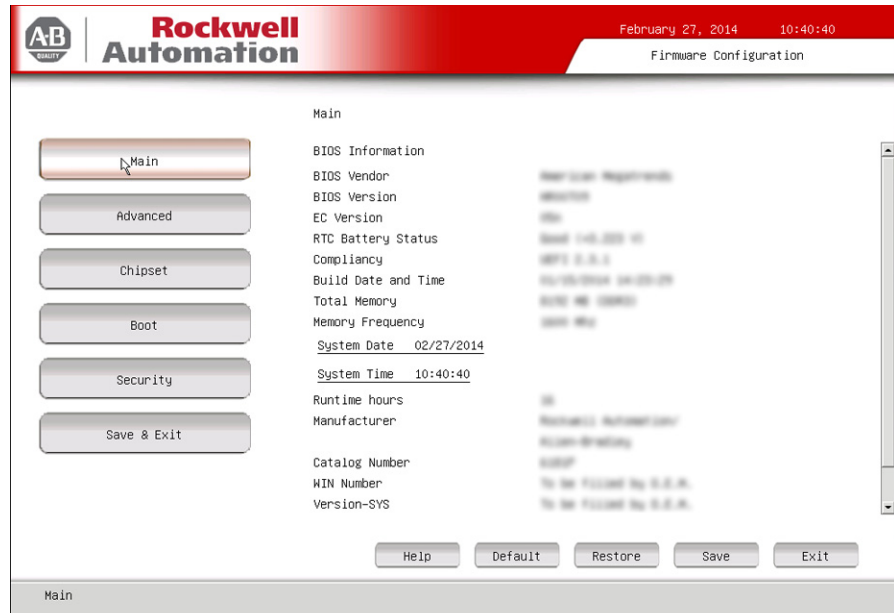
### Common Buttons at the Bottom of Screens

Most screens have these common buttons.



| Button               | Description   |
|----------------------|---|
| Help                 | Click for general help on using the set-up utility.             |
| Default              | Click to load the default values for all the set-up options.    |
| Restore              | Click to restore all set-up options to previously saved values. |
| Save                 | Click to save configuration changes.                            |
| Previous (not shown) | Click to navigate to the previous screen.                       |
| Exit                 | Click to close the set-up utility.                              |

## Main



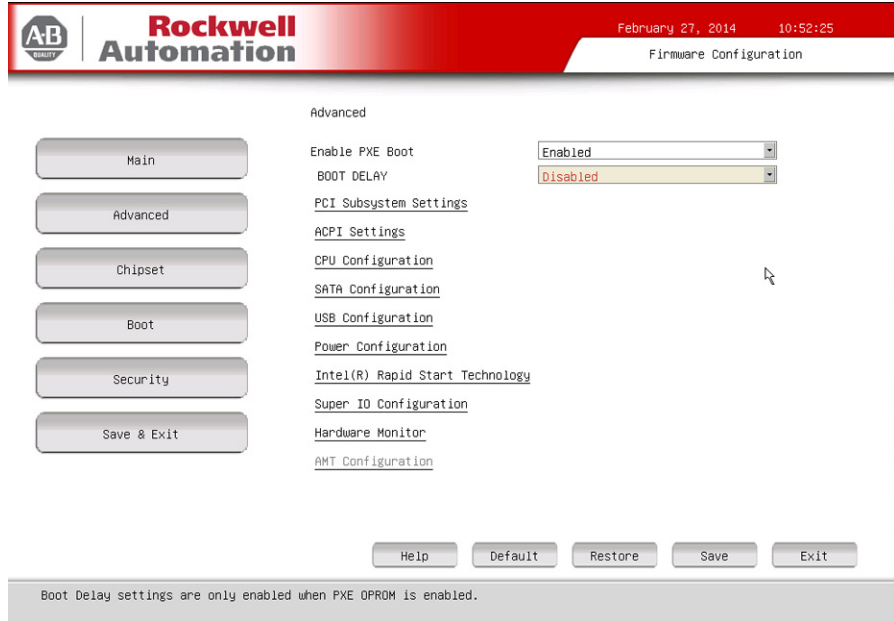
| Parameter <sup>(1)</sup> | Description   |
|--------------------------|---|
| BIOS Vendor              | BIOS manufacturer   |
| BIOS Version             | BIOS version information  |
| EC Version               | EC version information  |
| RTC Battery Status       | Standby battery voltage   |
| Compliancy               | UEFI version information  |
| Build Date and Time      | Date and time BIOS was created.   |
| Total Memory             | Total system memory and memory type (in parentheses)                        |
| Memory Frequency         | Frequency of installed memory   |
| System Date              | Set the system date.<br>Format: Weekday MM:DD:YYYY (Weekday Month:Day:Year) |
| System Time              | Set the system time.<br>Format: HH:MM:SS (Hour:Minute:Second)               |
| Runtime Hours            | Records the total hours of computer runtime.                                |
| Manufacturer             | System manufacturer   |
| Catalog Number           | Allen-Bradley catalog number with series letter                             |
| WIN Number               | Warranty information number   |
| Version-SYS              | System version, manufacture date  |
| Version-Board            | System board version information  |
| Serial Number            | Unique system serial number   |

(1) See [page 58](#) for an explanation of common buttons near the bottom of screen.

## Advanced

### Enable PXE Boot

When PXE boot is enabled, a computer boots from a server on a network before booting the operating system on the local hard drive.



| Parameter <sup>(1)</sup> | Description  |
|--------------------------|--|
| Enable PXE Boot          | Enables or disables boot option for legacy network devices.<br>Options: Enabled or Disabled (default)  |
| Boot Delay               | Enables or disables boot delay, which delays the booting process by the time selected.<br>Options: Disabled (default), 100s, 200s, 300s (seconds)<br><b>IMPORTANT:</b> This data field is only visible when PXE boot is enabled. |

(1) See [page 58](#) for an explanation of common buttons near the bottom of screen.

*PCI Subsystem Settings*

February 27, 2014 10:47:29  
Firmware Configuration

**Rockwell Automation**

PCI Subsystem Settings

PCI Bus Driver Version V 2.05.02  
PCI Common Settings

PERR# Generation Disabled  
SERR# Generation Disabled

Main  
Advanced  
Chipset  
Boot  
Security  
Save & Exit

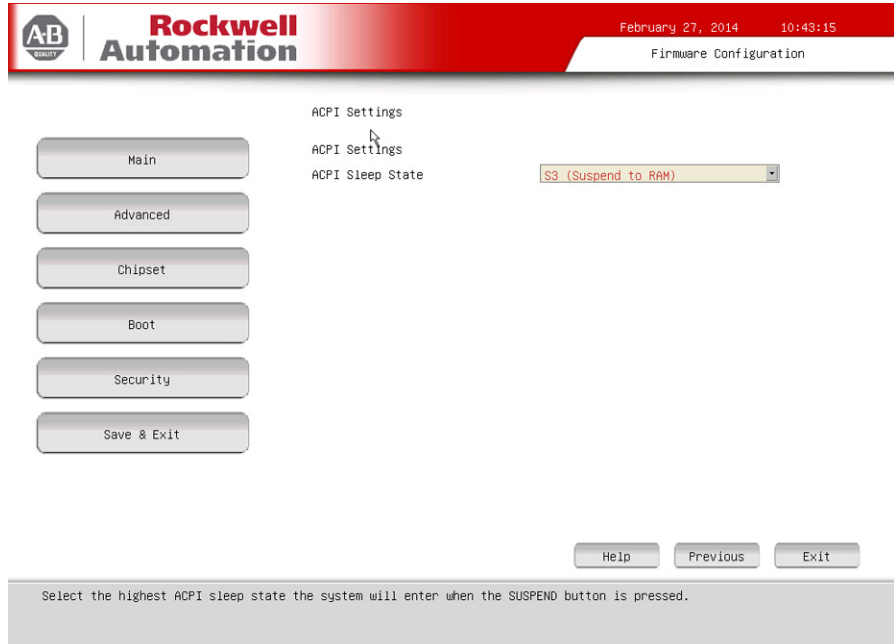
Help Previous Exit

Enables or Disables PCI Device to Generate PERR#.

| Parameter <sup>(1)</sup> | Description  |
|--------------------------|--|
| PCI Bus Driver Version   | Displays the PCI bus driver version information.   |
| PERR# Generation         | Enables or disables PCI Device to Generate PERR#. Options: Enabled or Disabled (default) |
| SERR# Generation         | Enables or disables PCI Device to Generate SERR#. Options: Enabled or Disabled (default) |

(1) See [page 58](#) for an explanation of common buttons near the bottom of screen.

### ACPI Settings



| Parameter <sup>(1)</sup> | Description   |
|--------------------------|---|
| ACPI Sleep State         | Use to set the ACPI sleep state and manage power.<br>Suspend Disabled: Computer power is totally removed by a mechanical switch.<br>S3 (default): RAM remains powered on. |

(1) See [page 58](#) for an explanation of common buttons near the bottom of screen.

*CPU Configuration*

February 27, 2014 10:43:57  
Firmware Configuration

**Rockwell Automation**

CPU Configuration

Intel(R) Core(TM) i7-4700EQ CPU @ 2.40GHz

Processor Cores 4

CPU Speed 2800 MHz

64-bit Supported

Hyper-threading Enabled

Intel Virtualization Technology (VT-x) Disabled

Intel Virtualization Technology for Directed I/O (VT-d) Disabled

Main  
Advanced  
Chipset  
Boot  
Security  
Save & Exit

Help Previous Exit

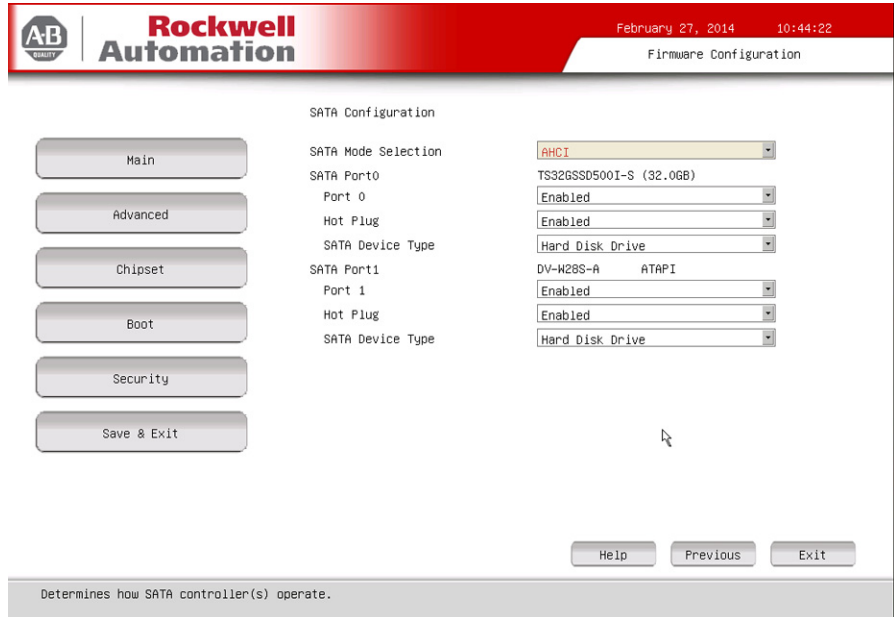
Enabled for Windows XP and Linux (OS optimized for Hyper-Threading Technology) and Disabled for other OS (OS not optimized for Hyper-Threading Technology). When Disabled only one thread per enabled core is enabled.

| Parameter <sup>(1)</sup>   | Description  |
|--|--|
| CPU Configuration  | Displays processor type and maximum speed.   |
| Processor Cores  | Displays processor core count.   |
| CPU Speed  | Displays maximum speed of the processor.   |
| 64-bit   | Displays 64-bit support status.  |
| Hyper-threading  | Enables or disables the hyper-threading technology.<br>Options: Enabled (default) or Disabled  |
| Intel Virtualization Technology (VT-x)                                 | When enabled, a Virtual Memory Manager (VMM) can use the extra hardware capabilities that are provided by Vanderpool Technology.<br>Options: Enabled or Disabled (default) |
| Intel Virtualization Technology for Directed I/O (VT-d) <sup>(2)</sup> | Enables or disables VT-d.<br>Options: Enabled or Disabled (default)  |

(1) See [page 58](#) for an explanation of common buttons near the bottom of screen.

(2) Supported on computers with Intel i7-4700EQ processors.

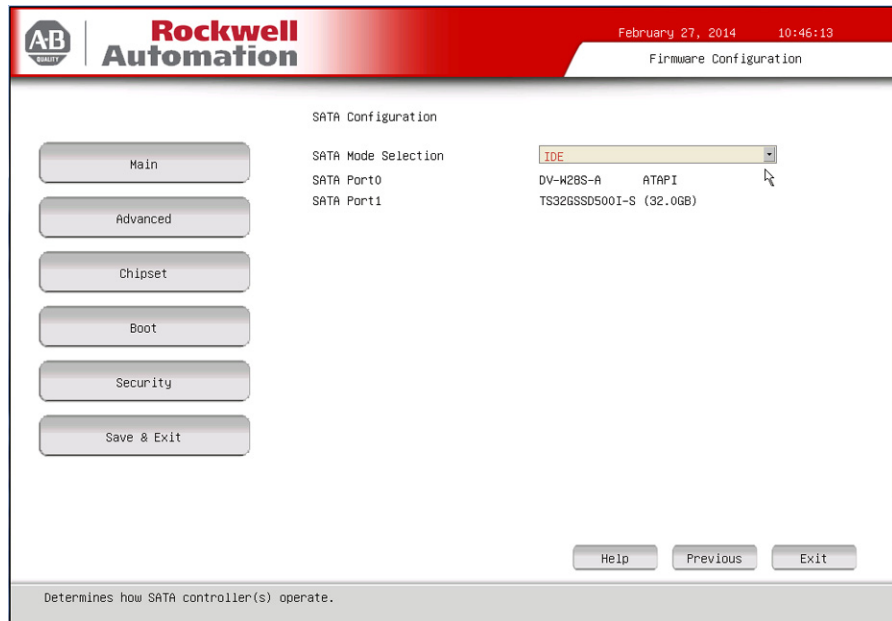
SATA Configuration (AHCI and RAID modes)



| Parameter <sup>(1)</sup> | Description   |
|--------------------------|---|
| SATA Mode Selection      | Select an operation mode for the onboard SATA controller.<br>Options: AHCI (default) or RAID  |
| SATA Port (0, 1)         | Indicates the drive make, model, and size.  |
| Port (0, 1)              | Enables or disables the SATA drive connected to the SATA port.<br>Options: Enabled (default) or Disabled  |
| Hot Plug                 | Enables or disables hot plug support for the SATA port.<br>Options: Enabled (default) or Disabled<br><b>IMPORTANT:</b> Make sure all writes to the drive are complete before you remove the drive from the system to avoid risk of data corruption. |
| SATA Device Type         | Indicates the drive type connected to the SATA port.<br>Options: Hard disk drive (default) or solid-state drive   |

(1) See [page 58](#) for an explanation of common buttons near the bottom of screen.

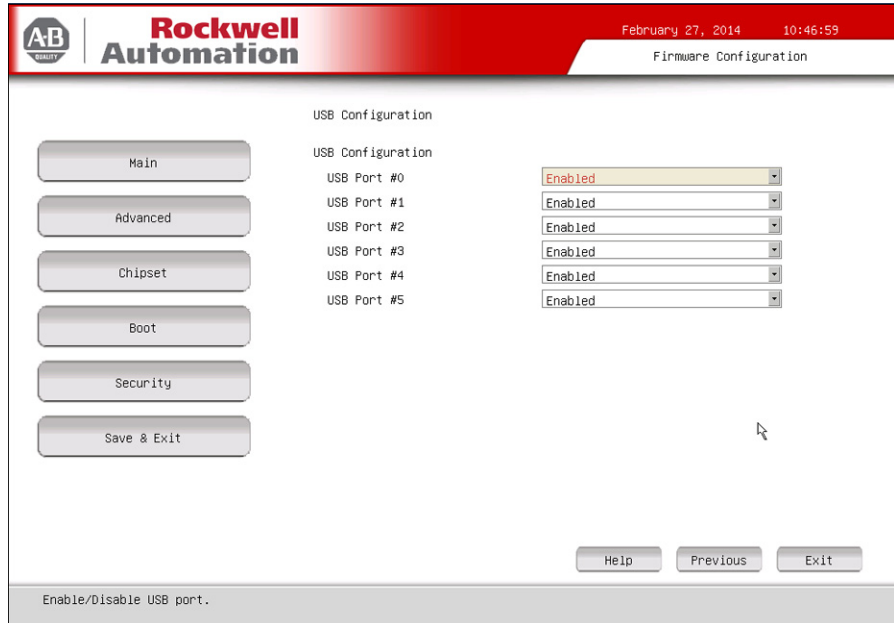


*SATA Configuration (IDE mode)*

| Parameter <sup>(1)</sup> | Description  |
|--------------------------|--|
| SATA Mode Selection      | Select an operation mode for the onboard SATA controller.<br>In this case, the IDE mode is selected. |
| SATA Port (0, 1)         | Indicates the drive make, model, and size.   |

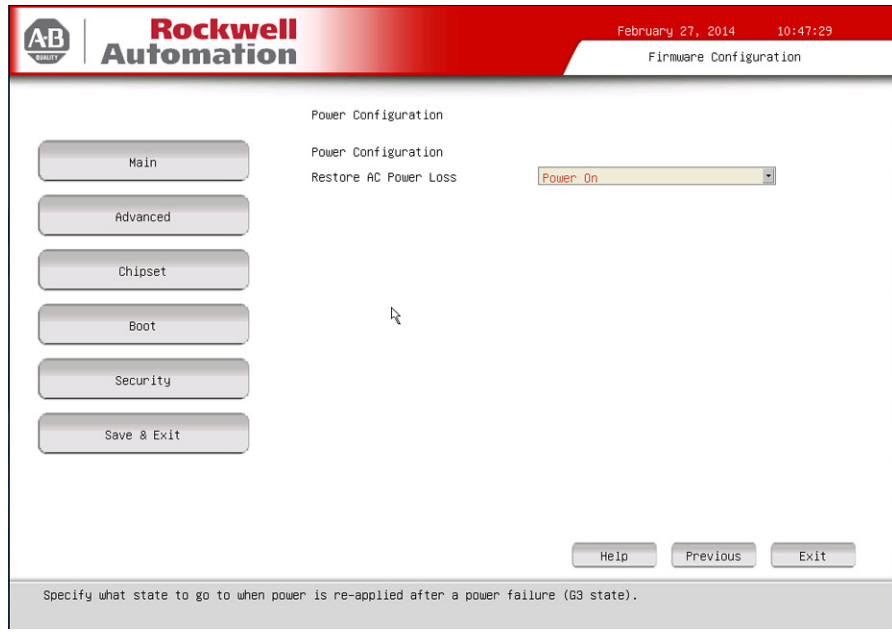
(1) See [page 58](#) for an explanation of common buttons near the bottom of screen.

### USB Configuration



| Parameter <sup>(1)</sup> | Description   |
|--------------------------|---|
| USB Ports                | <p>Enables or disables a USB port.<br/>                     Options: Enabled (default) or Disabled<br/>                     Port #0: Front<sup>(2)</sup> of computer<br/>                     Ports #1...#4: Bottom of computer<br/>                     Port #5: Internal (on motherboard; see <a href="#">page 14</a> for its location)</p> <p><b>IMPORTANT:</b> Disabling a USB port reduces access risk from unauthorized or malicious sources.</p> |

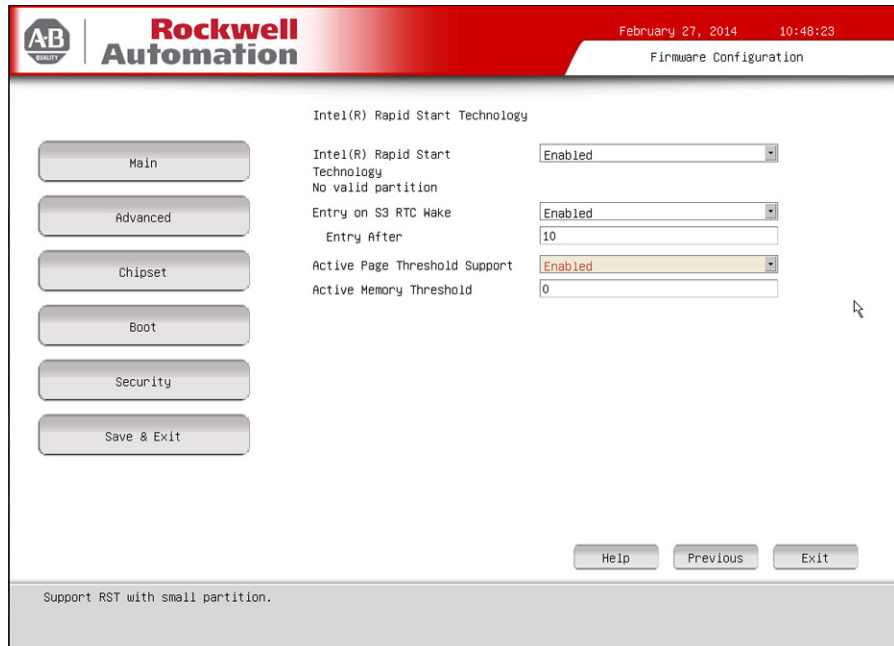
- (1) See [page 58](#) for an explanation of common buttons near the bottom of screen.
- (2) Applies only to display computers with aluminum bezel.

*Power Configuration*

| Parameter <sup>(1)</sup> | Description   |
|--------------------------|---|
| Restore AC Power Loss    | Specify what state to go to when power is reconnected after a power failure (G3 state).<br>Options: Power off, Power on (default), Last State |

(1) See [page 58](#) for an explanation of common buttons near the bottom of screen.

### Intel Rapid Start Technology

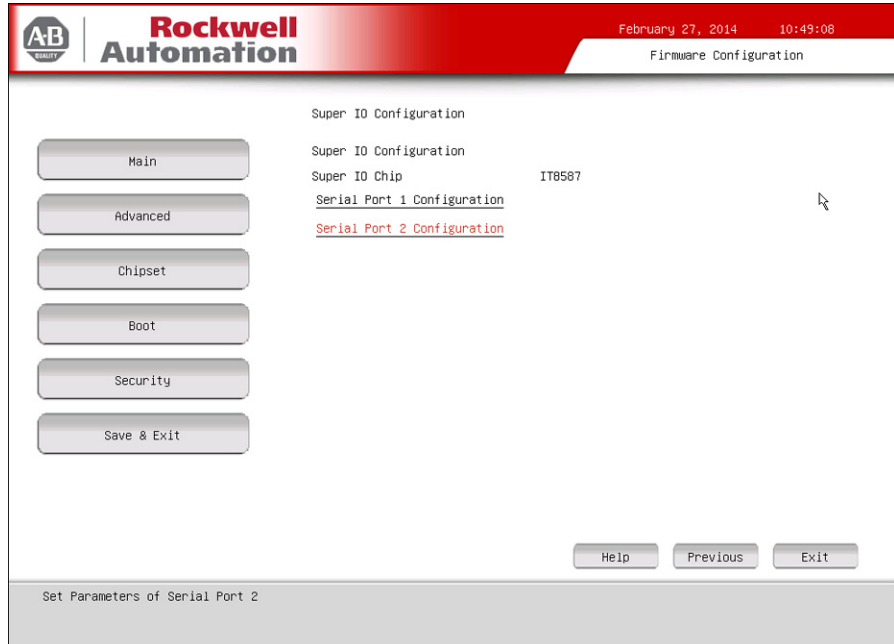


| Parameter <sup>(1)</sup>                     | Description   |
|--|---|
| Intel (R) Rapid Start Technology             | Enables or disables Intel Rapid Start Technology.<br>Options: Enabled or Disabled (default)<br><b>IMPORTANT:</b> The SSD must first have a private partition allocated that is equal in size to the computer RAM.                                       |
| Entry on S3 RTC Wake <sup>(2)</sup>          | Enables or disables Rapid Start invocation upon S3 RTC wake.<br>Options: Enabled (default) or Disabled  |
| Entry After <sup>(2)</sup>                   | Enables or disables RTC wake timer at S3 entry.<br>Number range: 10 (default) or 0 . . . 120  |
| Active Page Threshold Support <sup>(2)</sup> | Enables or disables support for Rapid Start Technology when the partition size is less than the amount of memory in the system.<br>Options: Enabled or Disabled (default)   |
| Active Memory Threshold <sup>(2)</sup>       | Enables the system to support Rapid Start Technology when the partition size is greater than the Active Page Threshold size in MB. When set to 0 (auto mode), it checks if partition size is enough at S3 entry.<br>Options: 0 (default), 1 . . . 65535 |

(1) See [page 58](#) for an explanation of common buttons near the bottom of screen.

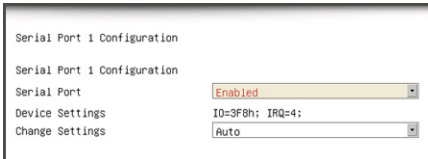
(2) This data field is visible only when the Intel (R) Rapid Start Technology data field is enabled.

### Super I/O Configuration



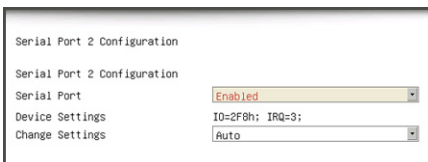
| Parameter <sup>(1)</sup>    | Description                                 |
|-----------------------------|---|
| Super I/O Chip              | Displays the Super I/O chipset information. |
| Serial Port 1 Configuration | Select to set parameters for serial port 1. |
| Serial Port 2 Configuration | Select to set parameters for serial port 2. |

(1) See [page 58](#) for an explanation of common buttons near the bottom of screen.



**Table 2 - Serial Port 1 Configuration**

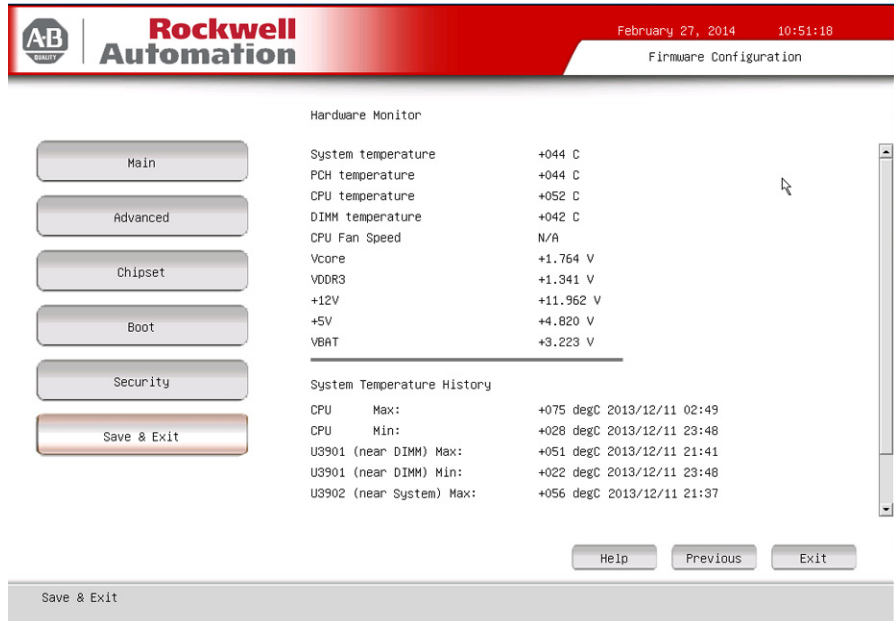
| Parameter       | Description  |
|-----------------|--|
| Serial Port     | Enables or disables the serial (COM1) port.<br>Options: Enabled (default) or Disabled  |
| Device Settings | Displays the Base I/O address and IRQ setting of serial port 1.  |
| Change Settings | Select an optimal setting for the super I/O device.<br>Options: Auto (default), IO=3F8h; IRQ=4, IO=2F8h; IRQ=4, IO=3E8h; IRQ=4, IO=2E8h; IRQ=4 |



**Table 3 - Serial Port 2 Configuration**

| Parameter       | Description  |
|-----------------|--|
| Serial Port     | Enables or disables the serial (COM2) port.<br>Options: Enabled (default) or Disabled  |
| Device Settings | Displays the Base I/O address and IRQ setting of serial port 2.  |
| Change Settings | Select an optimal setting for the super I/O device.<br>Options: Auto (default), IO=2F8h; IRQ=3, IO=3F8h; IRQ=3, IO=3E8h; IRQ=3, IO=2E8h; IRQ=3 |

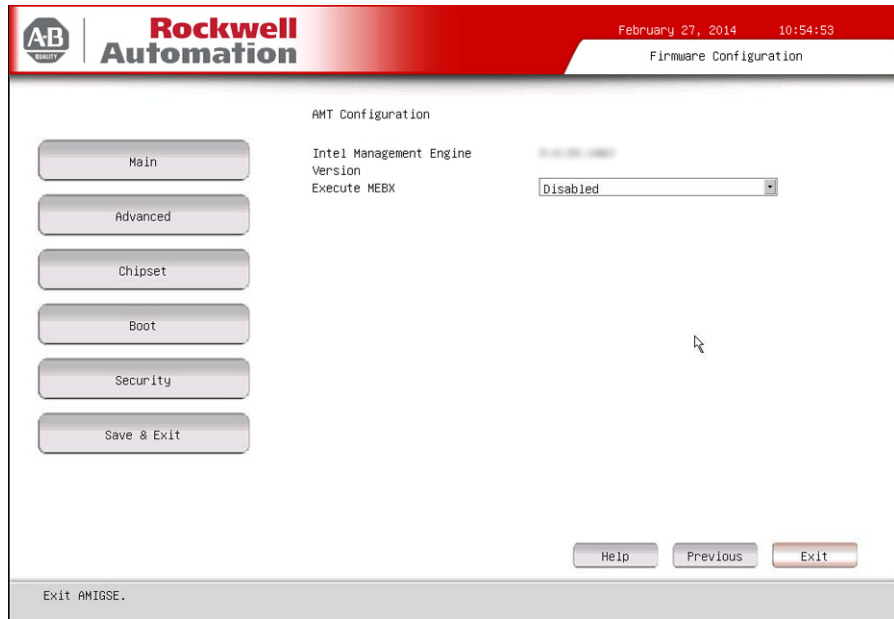
### Hardware Monitor



| Parameter <sup>(1)</sup>   | Description   |
|--|---|
| Hardware Monitor<br>System temperature<br>PCH temperature<br>CPU temperature<br>DIMM temperature<br>CPU Fan Speed <sup>(2)</sup><br>Vcore<br>VDDR3<br>+12V<br>+5V<br>VBAT  | Displays the current temperatures and core voltages of various hardware components.<br>All values are read-only.  |
| System Temperature History<br>CPU Max:<br>CPU Min:<br>U3901 (near DIMM) Max:<br>U3901 (near DIMM) Min:<br>U3902 (near System) Max:<br>U3902 (near System) Min:<br>U3904 (near PCH) Max:<br>U3904 (near PCH) Min: | Displays the minimum and maximum temperatures for the CPU and applicable sensors over a 24-hour time period (time stamp is 24-hour clock).<br>All values are read-only. |

(1) See [page 58](#) for an explanation of common buttons near the bottom of screen.

(2) This data field is visible only on computers with an Intel i7-4700EQ processor.

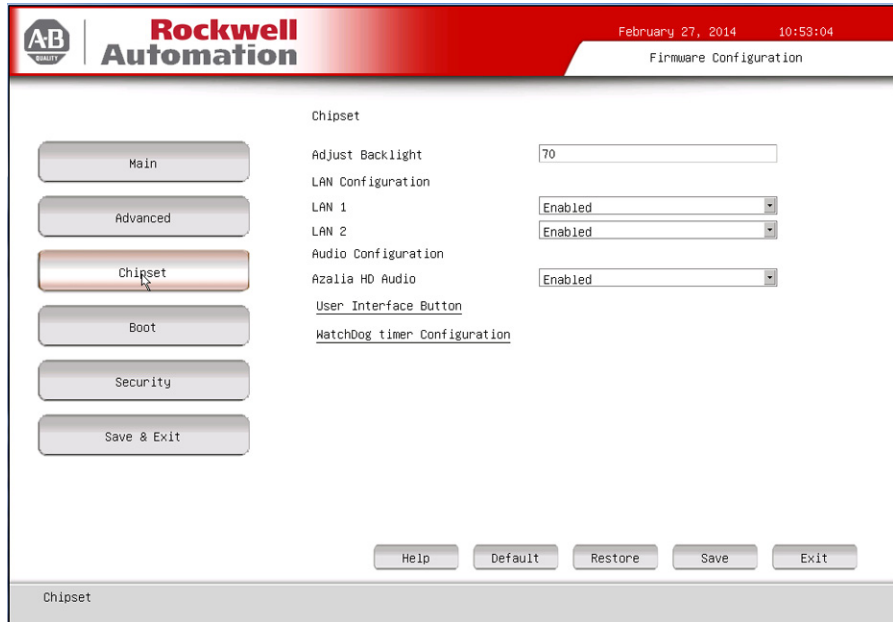
*AMT Configuration*

**IMPORTANT** AMT configuration is only available on Tier 3 computer models. See [page 10](#) to see if your computer qualifies.

| Parameter <sup>(1)</sup>        | Description   |
|---------------------------------|---|
| Intel Management Engine Version | Displays the Intel Management Engine version.   |
| Execute MEBx                    | Enables the Management Engine BIOS Extension (MEBx), which is accessed by pressing CTRL+P at POST. This function is used to configure AMT.<br>Options: Enabled or Disabled (default)                  |
| Unconfigure AMT/ME              | Lets you unconfigure any provisioned management settings for AMT/ME.<br>Options: Enabled or Disabled (default)<br><b>IMPORTANT:</b> 'Unconfigure AMT/ME' appears only when 'Execute MEBx' is enabled. |

(1) See [page 58](#) for an explanation of common buttons near the bottom of screen.

## Chipset



| Parameter <sup>(1)</sup>     | Description  |
|------------------------------|--|
| Adjust Backlight             | Adjust the internal LCD LED backlight brightness. Number range: 1 to 100 with 100 as full (100%) brightness; 70 is default. <b>IMPORTANT:</b> Increasing the brightness from the default setting reduces the life of the LED backlight, particularly at high temperatures. |
| LAN 1                        | Enables or disables onboard LAN1 controller. Options: Enabled (default) or Disabled  |
| LAN 2                        | Enables or disables onboard LAN2 controller. Options: Enabled (default) or Disabled  |
| Azalia HD Audio              | Enables or disables Azalia HD audio. Options: Enabled (default) or Disabled  |
| User Interface Button        | Select this item to set parameters for the user interface button.  |
| WatchDog timer Configuration | Select this item to set parameters for the watchdog timer.   |

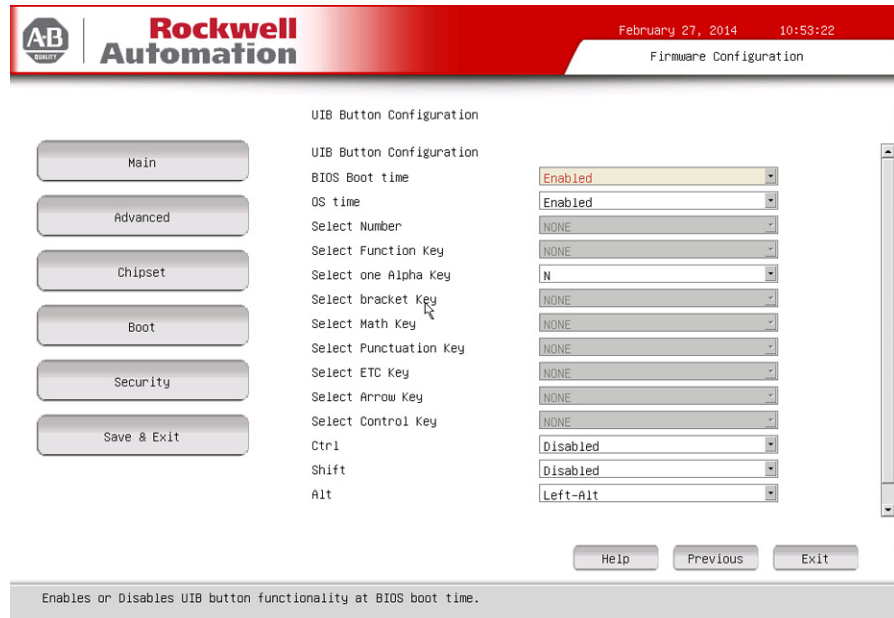
(1) See [page 58](#) for an explanation of common buttons near the bottom of screen.



### User Interface Button (UIB)

To access the UIB configuration screen, do the following.

1. On computer startup, enter the BIOS/UEFI.
2. On the Main screen, click Firmware Configuration.
3. On the Firmware Configuration screen, click Chipset.
4. On the Chipset screen, click User Interface Button.



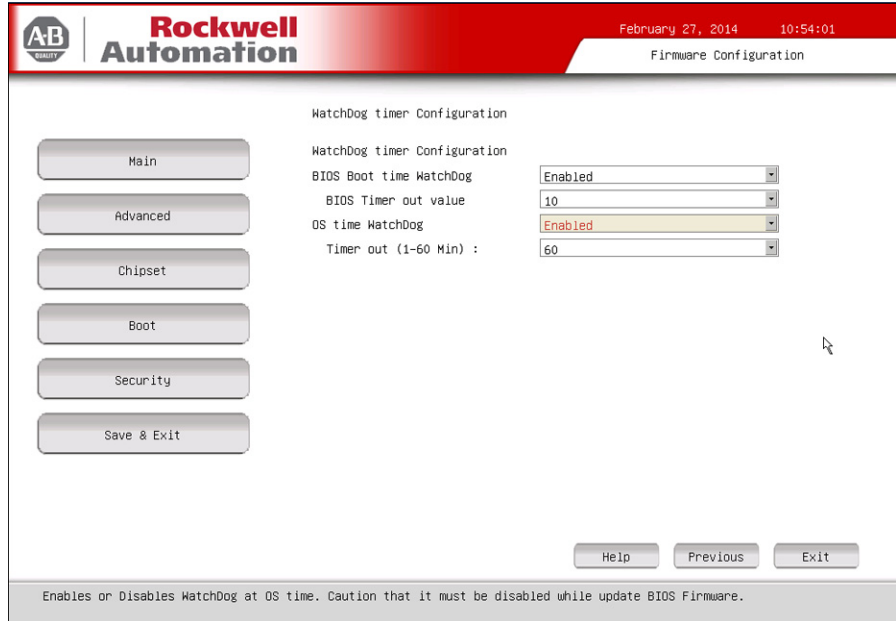
**IMPORTANT** This screen is only available on display computers with aluminum bezels.

| Parameter <sup>(1)</sup> | Description  |
|--------------------------|--|
| BIOS Boot time           | Enables or disables UIB access to UEFI menu during POST.<br>Options: Enabled (default) or Disabled                         |
| OS time                  | Enables or disables UIB functionality at OS time.<br>Options: Enabled (default) or Disabled                                |
| Select Number            | Select a number key to represent UIB.<br>Options: None (default) or 0...9  |
| Select Function Key      | Select a function key to represent UIB.<br>Options: None (default) or F1...F12   |
| Select one Alpha Key     | Select an alphabet letter (Alpha) key to represent UIB.<br>Options: N (default), a...z, or A...Z                           |
| Select bracket key       | Enables or disables key combination with bracket key.<br>Options: None (default) or (, ), [, ], {, }, <, >                 |
| Select Math key          | Enables or disables key combination with Math key.<br>Options: None (default) or =, +, -                                   |
| Select Punctuation key   | Enables or disables key combination with punctuation key.<br>Options: None (default) or `; ': " ? . ! &                    |
| Select ETC key           | Enables or disables key combination with ETC key.<br>Options: None (default) or ~, @, #, \$, %, ^, *, _ \, /,  , space bar |
| Select Arrow key         | Enables or disables key combination with arrow key.<br>Options: None (default) or Up, Down, Right, Left                    |

| Parameter <sup>(1)</sup> | Description  |
|--------------------------|--|
| Ctrl                     | Enables or disables key combination with CTRL key.<br>Options: Disabled (default), Left-CTRL, or Right-CTRL    |
| Shift                    | Enables or disables key combination with Shift key.<br>Options: Disabled (default), Left-Shift, or Right-Shift |
| Alt                      | Enables or disables key combination with ALT key.<br>Options: Disabled, Left-ALT (default), or Right-ALT       |

(1) See [page 58](#) for an explanation of common buttons near the bottom of screen.

### Watchdog Timer



| Parameter <sup>(1)</sup>            | Description   |
|-------------------------------------|---|
| BIOS Boot time WatchDog             | Enables or disables BIOS boot timeout.<br>Options: Enabled or Disabled (default)            |
| BIOS Timer Out value <sup>(2)</sup> | Set BIOS timer timeout value (10, 20, or 30 minutes). 10 is default.                        |
| OS time WatchDog                    | Enables or disables OS timeout.<br>Options: Enabled or Disabled (default)                   |
| Timer Out (1-60 Min) <sup>(3)</sup> | Set WatchDog timer timeout value (1...60 minutes) in 1 minute increments.<br>60 is default. |

(1) See [page 58](#) for an explanation of common buttons near the bottom of screen.

(2) This field is only visible when BIOS Boot time Watchdog is enabled.

(3) This field is only visible when OS time Watchdog is enabled.

**IMPORTANT** If you enable the BIOS Boot time Watchdog, then it must be disabled before you update the BIOS firmware.

## Boot

The screenshot shows the 'Boot' configuration screen in the Rockwell Automation UEFI Utility. The interface includes a navigation pane on the left with buttons for 'Main', 'Advanced', 'Chipset', 'Boot' (selected), 'Security', and 'Save & Exit'. The main content area is titled 'Boot' and contains the following settings:

- Boot Configuration:** A dropdown menu set to 'On'.
- Bootup NumLock State:** A dropdown menu set to 'On'.
- Quiet Boot:** A dropdown menu set to 'Disabled'.
- Boot Option Priorities:** A link to a dialog box.
- Boot Priority List:** A link to a dialog box.
- USB Boot Priorities:** A link to a dialog box.
- CD-DVD ROM Boot Priorities:** A link to a dialog box.
- Hard-Drive Boot Priorities:** A link to a dialog box.

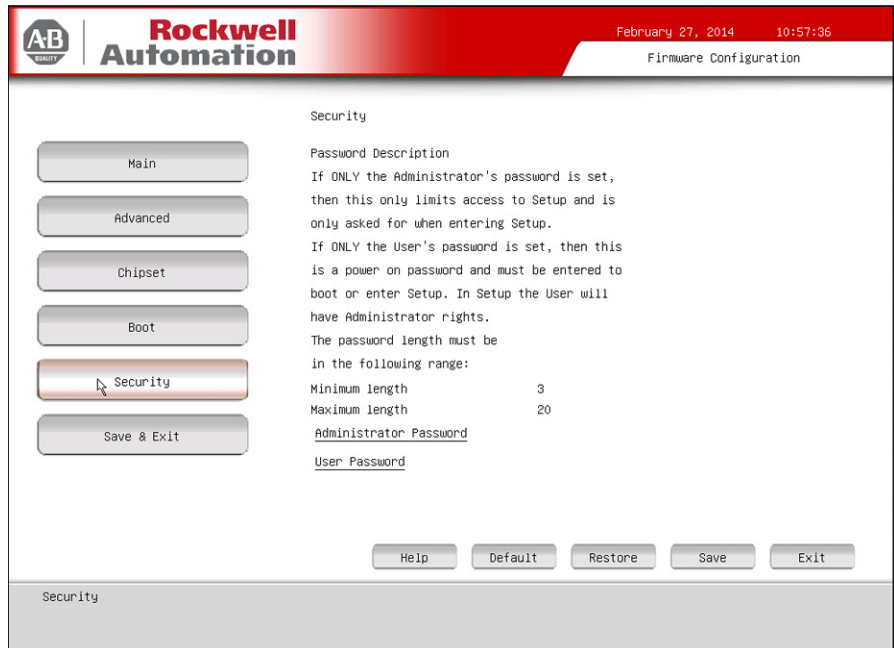
At the bottom of the screen, there are buttons for 'Help', 'Default', 'Restore', 'Save', and 'Exit'. The status bar at the very bottom shows 'Boot'.

| Parameter <sup>(1)</sup>                  | Description   |
|---|---|
| Bootup NumLock State                      | Enables or disables the Num Lock key on boot.<br>Option: On (default) or Off  |
| Quiet Boot                                | Enables or disables Quiet Boot option.<br>Option: Enabled or Disabled (default)<br><b>IMPORTANT:</b> When enabled, this option hides the POST screen messages at computer startup.  |
| Boot Priority List                        | Change the boot order. By default, these devices are the boot priority: <ul style="list-style-type: none"> <li>• USB key</li> <li>• CD-ROM</li> <li>• SSD</li> <li>• PXE</li> <li>• UEFI shell</li> <li>• PCI/PCIe RAID/SCSI/SCSI card</li> </ul> Follow instructions in the dialog box to change the boot order, and to enable or disable options. |
| USB Boot Priorities                       | Change the USB boot order through a dialog box.<br>See the Boot Priority List description for the dialog box options.   |
| CD-DVD ROM Boot Priorities <sup>(2)</sup> | Change the CD-DVD ROM boot order through a dialog box.<br>See the Boot Priority List description for the dialog box options.  |
| Hard-Drive Boot Priorities                | Change the hard drive boot order through a dialog box.<br>See the Boot Priority List description for the dialog box options.  |

(1) See [page 58](#) for an explanation of common buttons near the bottom of screen.

(2) This data field is only visible on computers with CD-ROM drives.

## Security



| Parameter <sup>(1)</sup> | Description  |
|--------------------------|--|
| Administrator Password   | <p>Sets the administrator password. Use this password to reduce access risk from unauthorized or malicious sources.</p> <p><b>IMPORTANT:</b> If you forget the administrator password, there are two ways to reset it:</p> <ul style="list-style-type: none"> <li>Remove and replace the battery; see <a href="#">Replace the RTC Battery on page 49</a>.</li> <li>Clear the UEFI; see <a href="#">Clear the UEFI on page 91</a>.</li> </ul> |
| User Password            | <p>Sets the user password. Use this password to reduce access risk from unauthorized or malicious sources.</p> <p><b>IMPORTANT:</b> If you forget the administrator password, there are two ways to reset it:</p> <ul style="list-style-type: none"> <li>Remove and replace the battery; see <a href="#">Replace the RTC Battery on page 49</a>.</li> <li>Clear the UEFI; see <a href="#">Clear the UEFI on page 91</a>.</li> </ul>          |

(1) See [page 58](#) for an explanation of common buttons near the bottom of screen.

## Save & Exit

February 27, 2014 10:58:06  
Firmware Configuration

Save & Exit

Main  
Advanced  
Chipset  
Boot  
Security  
Save & Exit

Save & Exit

Save Changes and Reset  
Discard Changes and Reset  
Restore Defaults

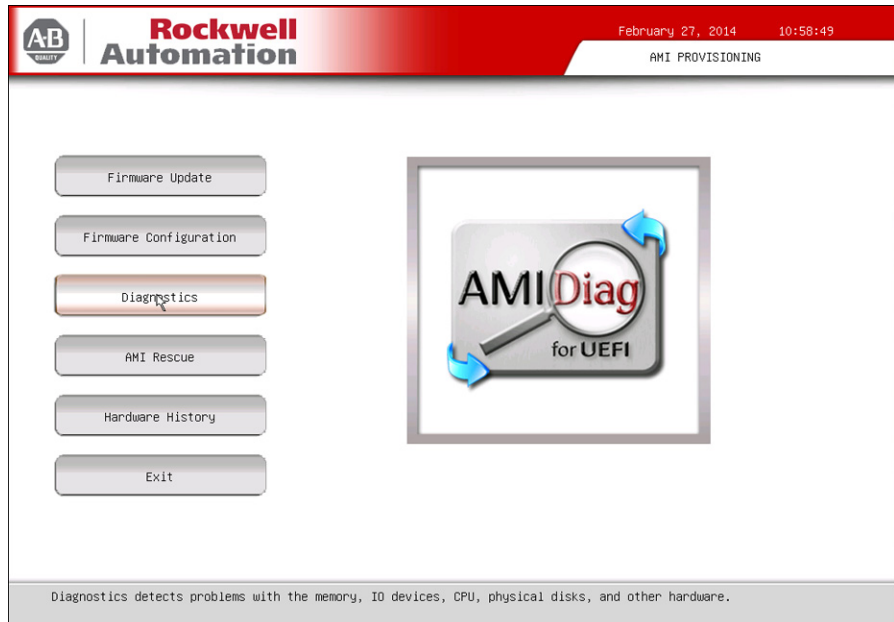
Help Default Restore Save Exit

| Parameter <sup>(1)</sup>  | Description   |
|---------------------------|---|
| Save Changes and Reset    | Saves changes that are made and closes the set-up utility.    |
| Discard Changes and Reset | Discards changes that are made and closes the set-up utility. |
| Restore Defaults          | Loads the optimal defaults in the set-up menu.                |

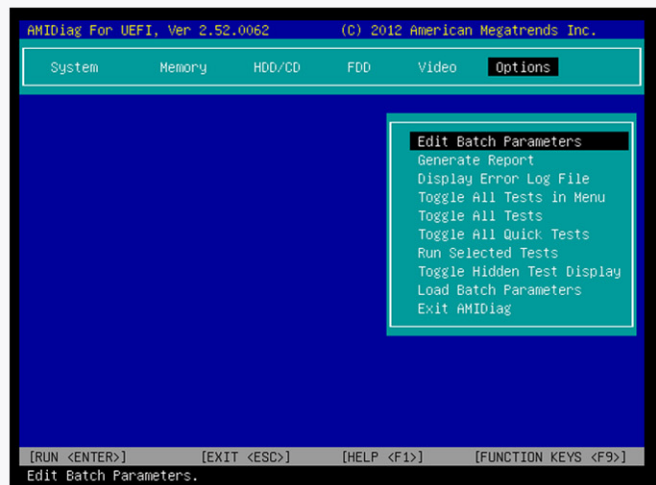
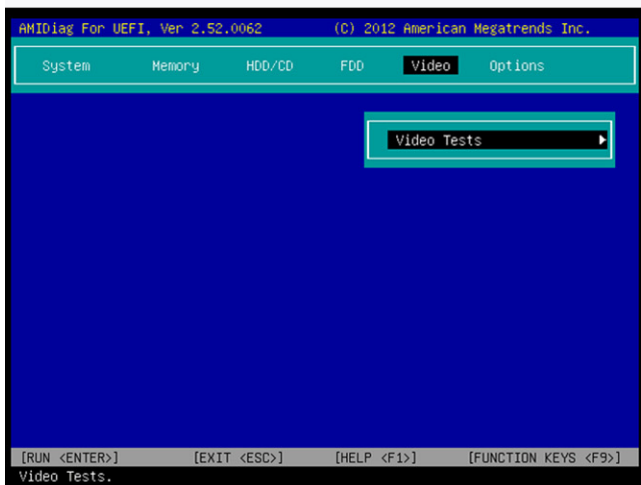
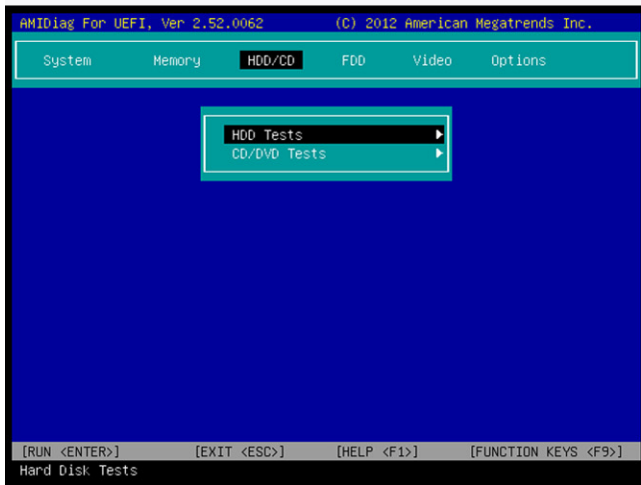
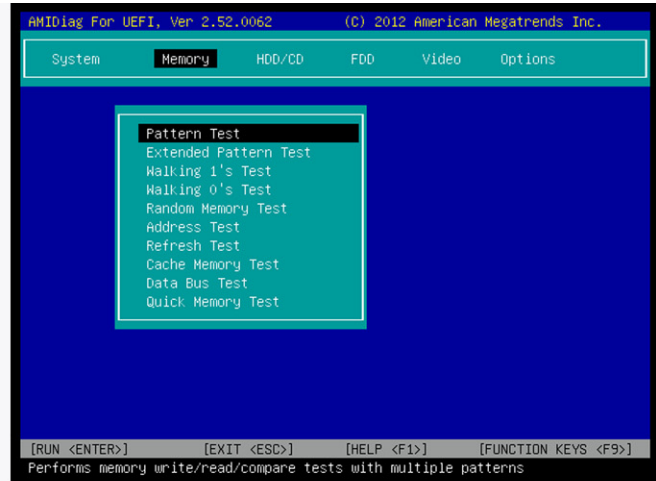
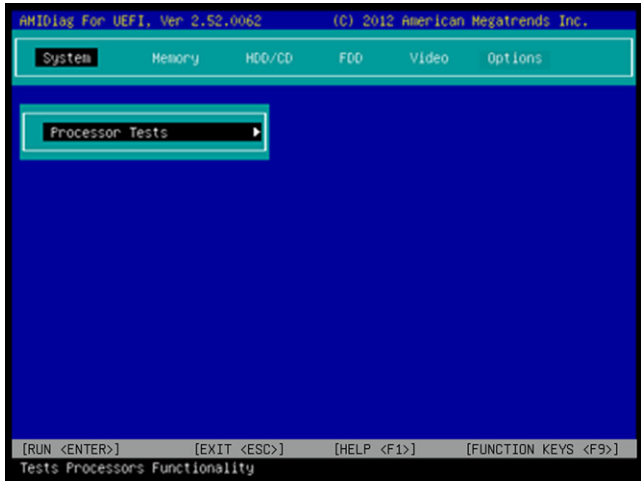
(1) See [page 58](#) for an explanation of common buttons near the bottom of screen.

## Diagnostics

The Diagnostics menu lets you run the diagnostics utility to determine the cause of the system malfunction by testing computer components, such as the processor, memory, HDD, ODD, video, and other hardware.



Select a menu option by pressing the up ↑ or down ↓ arrow keys and pressing Enter when a menu is highlighted. Press the left ← or right → arrow keys to toggle between the six Diagnostics menu selections.



The following table lists the shortcut options in the Diagnostics menu.

| Button | Description   |
|--------|---|
| Esc    | Stops a test in progress or exits Diagnostics from any of the six menu options. |
| Enter  | Runs the highlighted test or option.  |
| F1     | Displays the Help screens.  |
| F2     | Edits batch parameters.   |
| F3     | Loads batch parameters.   |
| F4     | Saves batch parameters.   |
| F5     | Selects or deselects the current test.  |
| F6     | Selects or deselects all tests in the menu.                                     |
| F7     | Selects or deselects all tests.   |
| F8     | Selects or deselects all quick tests.   |
| F9     | Displays a list of the Diagnostic function keys.                                |
| F10    | Runs the selected test or tests.  |

## AMI Rescue

The AMI Rescue menu lets you back up the system image on your computer and restore that image.



**IMPORTANT** The following instructions are for the built-in backup and restore utility, AMI Rescue. You can also use third party utility or software to create an image backup and restore.

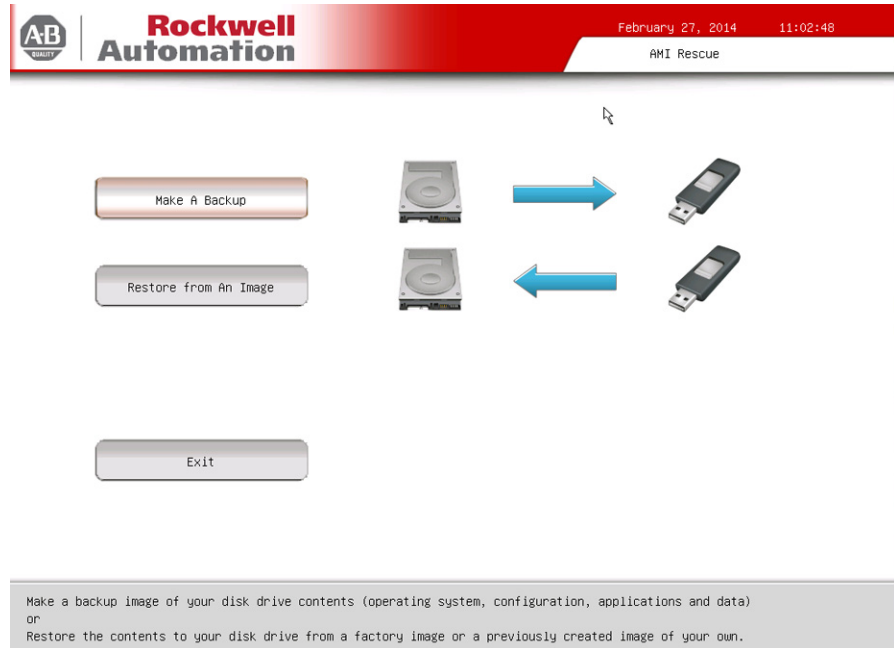
System images are also available from the Rockwell Automation Product Compatibility and Download Center:  
<http://www.rockwellautomation.com/support/pcdc.page>.

The Make A Backup function does the following:

- Overwrite any data stored in a hidden partition.
- Save any data as a new image file stored in a hidden partition.
- Save any data on a mass storage device.



The Restore from An Image function overwrites any data on the primary operating system partition on the internal drive.



| Parameter             | Description  |
|-----------------------|--|
| Make A Backup         | Click to take you through steps to back up the desired data. |
| Restore from An Image | Click to take you through steps to restore the desired data. |
| Exit                  | Click to exit the AMI Rescue or press F4.                    |

## Make a Backup

Follow these steps to back up the system image.

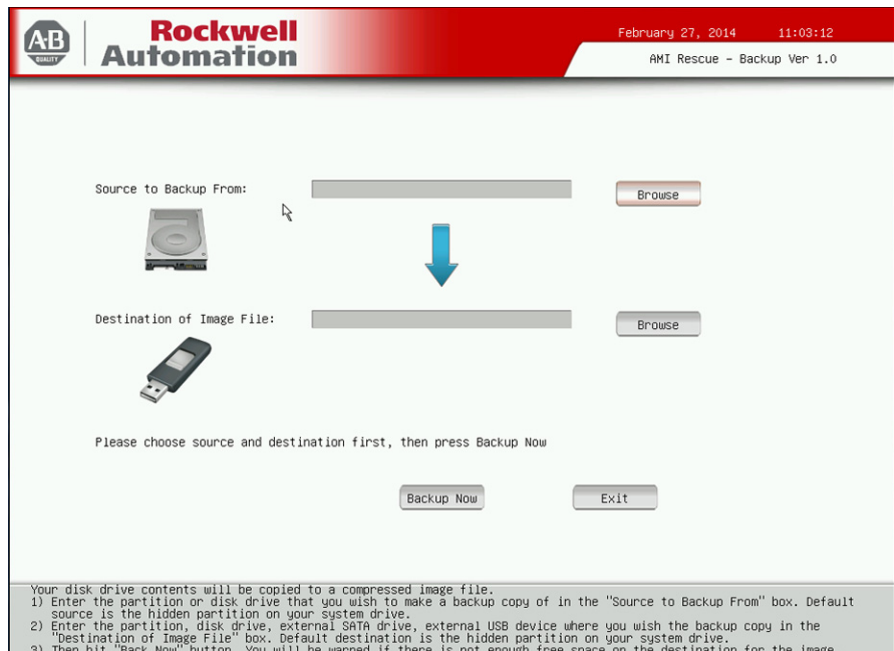
---

**IMPORTANT** Attach a FAT32-formatted USB storage device to the computer before you perform these steps. Use a USB storage device appropriately sized for the amount of data being backed up.

---

1. Click the AMI Rescue menu to access the AMI Rescue screen.
2. Click Make a Backup.
3. In the Source to Backup From field, click Browse to locate the backup source.

The default backup source is the hidden partition on your hard drive.



4. In the Destination of Image File field, click Browse to locate the destination source.

The default destination source is the hidden partition on your hard drive.

5. Click Backup Now to start the backup process.

---

**IMPORTANT** A warning appears if there is not enough free space on the destination source.

---

## Restore from an Image

Perform the following steps to restore your computer from a system image backup.

---

**IMPORTANT** When you restore from a back-up image, all data on the target drive is replaced. Make sure all data is backed up before you proceed with the following steps.

---

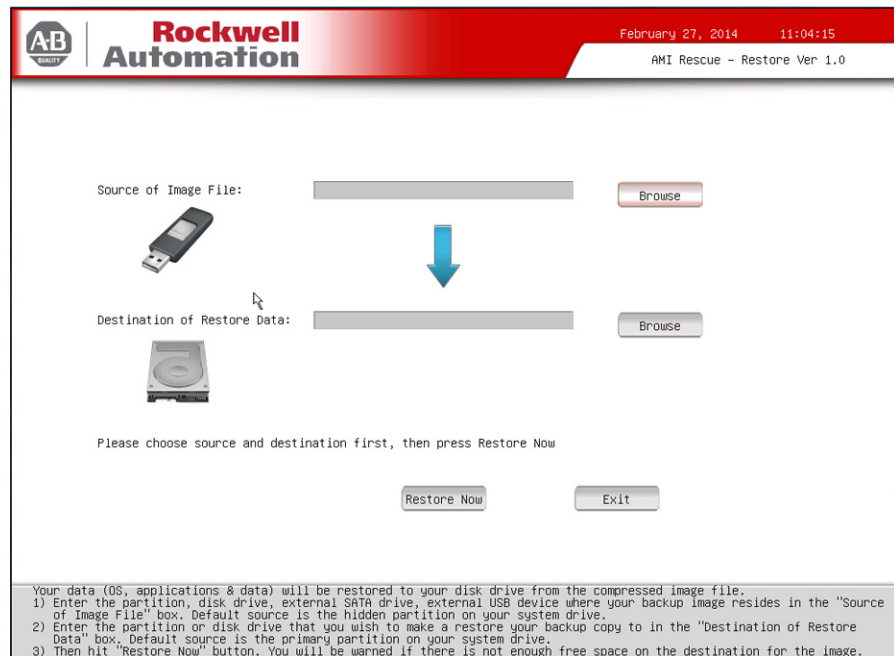
1. Click the AMI Rescue menu to access the AMI Restore screen.
2. Click Restore from an Image.
3. In the Source of Image File field, click Browse to locate the image source.

The default image source is the hidden partition on your hard drive.

---

**IMPORTANT** Any USB mass storage drive must be formatted as FAT32, have a drive label other than 'Recovery', and be non-blank.

---



4. In the Destination of Restore Data field, click Browse to locate the destination source.

The default destination source is the primary partition on your hard drive.

5. Click Restore Now to start the restoration process.

---

**IMPORTANT** A warning appears if there is not enough free space on the destination source.

---

## Hardware History

You can view various hardware parameters from the Hardware History menu. It shows the total hours that the computer has been powered up, or runtime. It also displays the minimum and maximum temperatures over the entire runtime.

All displayed values are read-only, and the time stamp is 24-hour clock.

| Sensor Location     | Max (°C) | Timestamp (YYYY/MM/DD HH:MM) | Min (°C) | Timestamp (YYYY/MM/DD HH:MM) |
|---------------------|----------|------------------------------|----------|------------------------------|
| CPU                 | +075     | 2009/01/03 02:49             | +028     | 2013/12/11 23:48             |
| U3901 (near DIMM)   | +051     | 2009/01/02 21:41             | +022     | 2013/12/11 23:48             |
| U3902 (near System) | +056     | 2009/01/02 21:37             | +023     | 2013/12/11 23:48             |
| U3904 (near PCH)    | +054     | 2009/01/02 22:18             | +022     | 2013/12/11 23:48             |

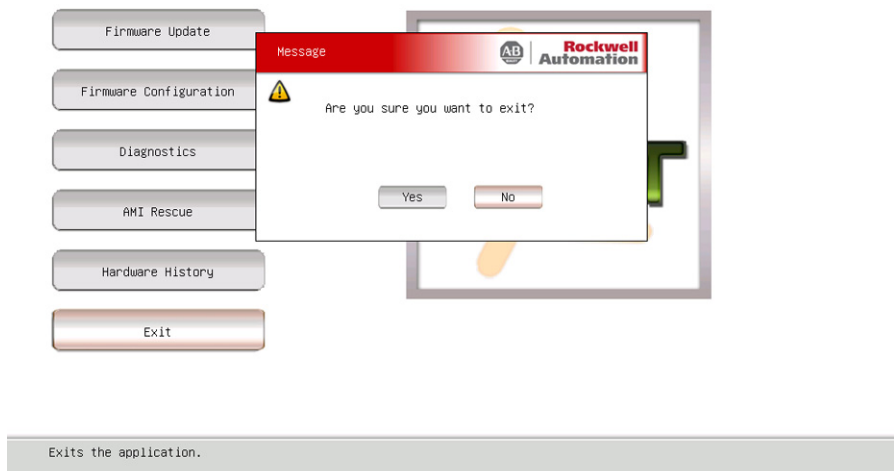
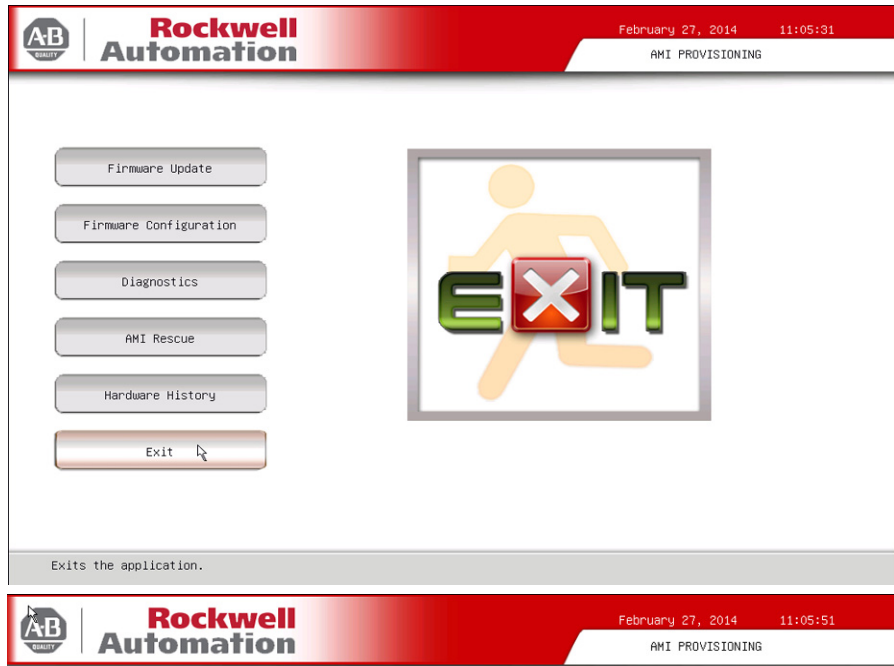
|               |     |       |
|---------------|-----|-------|
| Runtime Hours | 017 | Hours |
|---------------|-----|-------|

Exit

| Menu        | Description   |
|-------------|---|
| Temperature | Same hardware temperatures as identified in System Temperature History of Hardware Monitor; see <a href="#">page 70</a> for more information. |
| Time        | Total runtime hours. In the above screen shot, the runtime hours are 17.  |
| Exit        | Returns you to the set-up menu screen ( <a href="#">page 56</a> ).  |

# Exit

Use the Exit menu to close the UEFI set-up utility.



## Notes:

## Troubleshoot the System

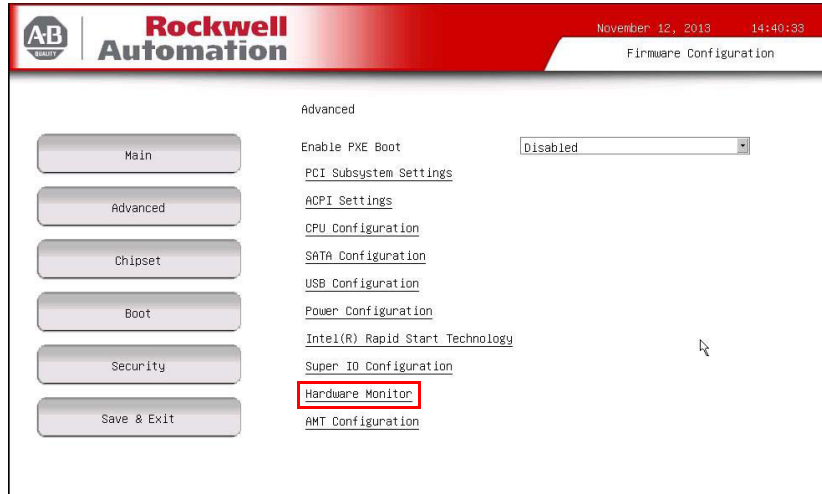
| Topic                          | Page |
|--------------------------------|------|
| Hardware Monitoring            | 87   |
| Troubleshooting                | 88   |
| Diagnostics                    | 89   |
| Load the System Defaults       | 90   |
| Clear the UEFI                 | 91   |
| Ship or Transport the Computer | 91   |
| Dispose of the Computer        | 92   |

### Hardware Monitoring

The built-in hardware monitor of the computer tracks the operating threshold levels of the voltage and temperature sensors.

Follow these steps to determine whether an operating threshold has been reached.

1. Shut down the computer by using the appropriate method for the installed operating system.  
See [Shut Down the Computer on page 39](#) for more information.
2. Apply power to the computer.
3. During POST, press F2 to access the UEFI set-up utility.
4. Click Firmware Configuration on the Main Menu screen.
5. Click Advanced from the Firmware Configuration main screen.
6. Click Hardware Monitor on the Advanced screen.



See [Hardware History on page 84](#) for what information is shown.

Use this menu to determine if there is an issue with internal voltages or component temperatures.

## Troubleshooting

Follow these steps to identify and isolate an issue with computer operation.

1. Shut down the computer by using the appropriate method for the installed operating system.

See [Shut Down the Computer on page 39](#) for more information.

2. Disconnect power to the computer.
3. Disconnect all peripheral devices from the computer.
4. If a keyboard and mouse are used, verify that they are properly connected.
5. If an external display is used, verify that it is properly connected.
6. Connect power to the computer. During POST, one of three events occurs:
  - The start-up process is completed.
  - A nonfatal error occurs and the related error message is displayed.
  - A fatal error occurs and the start-up process terminates.

| If  | Then   |
|---|--|
| The computer starts   | Disconnect all peripheral devices and reconnect them one at a time until the issue occurs. |
| The issue is with a specific software or driver                                     | Reinstall the software or driver.  |
| The issue is not related specifically to software, a driver, or a peripheral device | Proceed to <a href="#">Diagnostics on page 89</a> .  |



## Diagnostics

If you completed the troubleshooting steps and issues remain, use the Diagnostics menu in the UEFI set-up utility to isolate the issue. Diagnostics tests computer components to determine the cause of a malfunction.

- 
- IMPORTANT** Before you access diagnostics, first perform these steps:
- Connect an external keyboard to the computer
  - If you plan to test the CD-ROM drive, install a media disk
  - If you plan to update firmware, connect a USB drive with new firmware
- 

Press F2 during POST or press F10 any time before the Windows OS starts to access the UEFI set-up utility:

- F2 during POST accesses the main menu of the UEFI set-up utility. Select Diagnostics on the main menu.

---

**IMPORTANT** For display computers with aluminum bezels, you can access the diagnostic utility during POST by pressing the UIB on the front of the display; see [page 16](#) for more information about the UIB.

---

- F10 directly accesses the Diagnostics menu of the UEFI set-up utility.

Follow these steps to save diagnostic reports.

1. Select Generate Report in the Options menu and press Enter.
2. Select Report destination and press Enter.
3. Select File and press Enter.
4. Select the device path to generate the log report and press Enter.  
If you need to generate the report in the current file system, press Enter. Otherwise, select Continue and press Enter.
5. Enter log file details (file name and heading) for generating the report. The default file name is AMIDiag.LOG.
6. Set the report parameters, such as log errors, log test activities, log test start time, log test end time, log errors only, log errors only with time, Append to old log file, Log device info on fail, Log device info on abort.
7. To exit the submenu, Select Continue and press Enter.

You do not need to disconnect or move your computer to perform an initial diagnosis. The selected test affects the process, which can take as little as 5 minutes or as long as 8 hours. After Diagnostics has run, you can generate a report for analysis by a technical support representative, which expedites any necessary repair process.

## Load the System Defaults

If the computer fails after you make changes in the set-up menus, load the system default settings to correct the error. These default settings have been selected to optimize computer performance.

Follow these steps to load the system defaults.

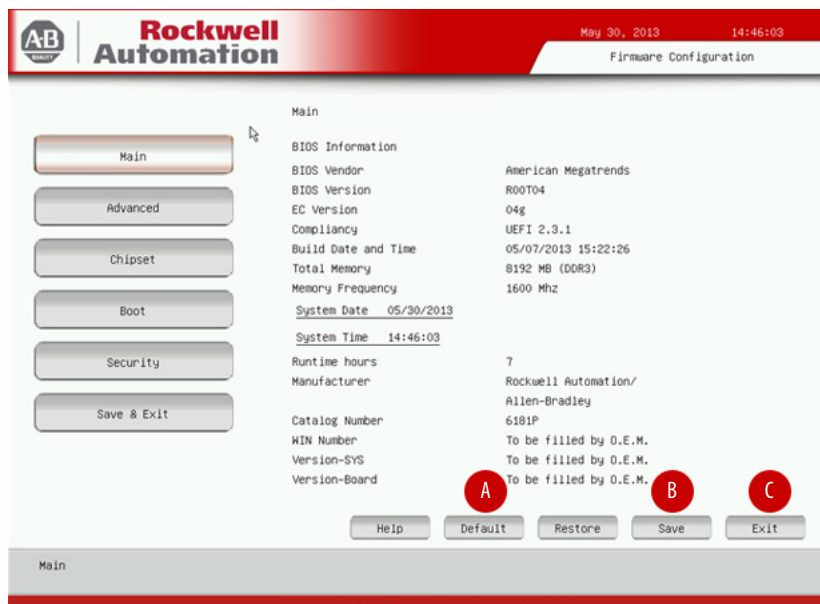
1. Restart the computer as specified in [Restart the Computer on page 39](#).
2. During POST, press F2 to access the UEFI set-up utility.

---

**IMPORTANT** For display computers with aluminum bezels, you can access the diagnostic utility during POST by pressing the UIB on the front of the display; see [page 16](#) for more information about the UIB.

---

3. Click Firmware Configuration on the set-up screen.
4. Click Default (A) on the Main screen.
5. Click Save (B) to save your changes.
6. Click Exit (C) to exit the UEFI set-up utility.



## Clear the UEFI

You must clear the system configuration values that are stored in the UEFI if the following conditions are present:

- The system configuration has been corrupted
- An incorrect setting has caused error messages to be unreadable
- You cannot access the UEFI set-up utility to load the system defaults

Follow these steps to clear the UEFI.

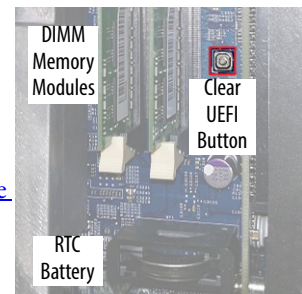
1. Back up all system data and then shut down the computer.
2. Follow the steps for [Pre-configuration on page 42](#).
3. Remove the cover as detailed in [Remove the Cover on page 43](#).

---

**IMPORTANT** Use an antistatic wriststrap that is connected to a grounded surface.

---

4. Locate the Clear UEFI button on the motherboard.
5. Press and hold the button for three seconds before you release it.
6. Reinstall the cover as detailed in [Reinstall the Cover on page 44](#).
7. Follow the steps for [Post-configuration on page 43](#).




---

**IMPORTANT** When you clear the UEFI, all UEFI settings return to their defaults. Settings other than default must be reconfigured after the UEFI is cleared.

---

8. During POST, press F2 to access the UEFI set-up utility and reconfigure settings.

## Ship or Transport the Computer

If you must ship the computer via common carrier or otherwise transport it to another location for service or any other reason, you must first uninstall the computer and place it in its original packing material.

---

**IMPORTANT** **ATTENTION:** Do not ship or transport the computer when it is installed in a machine, panel, or rack. To avoid damage to the computer, you must uninstall the computer and place it in its original packing material before shipping. Rockwell Automation is not responsible for damage to a computer that is shipped or transported while it is installed in a machine, panel, or rack.

---

## Dispose of the Computer



---

At the end of its life, collect the computer separately from any unsorted municipal waste.

---

You cannot dispose of computer equipment like other waste material. Most computers and monitors contain heavy metals that can contaminate the earth. Therefore, check with local health and sanitation agencies for ways to safely dispose of computer equipment.

If a storage drive is part of what you plan to dispose, then verify that any data on it has been permanently erased or that you destroy the drive before it is disposed.

## Use a Touch Screen

| Topic                               | Page |
|-------------------------------------|------|
| Touch Screen Technology             | 93   |
| Driver Software                     | 93   |
| PCAP Touch Screen Technology        | 94   |
| Resistive Technology                | 94   |
| Calibrate the Resistive Touchscreen | 95   |

### Touch Screen Technology

Integrated display computers are shipped with the touch screen controller installed and connected. The touch screen controller connects internally to a USB port.

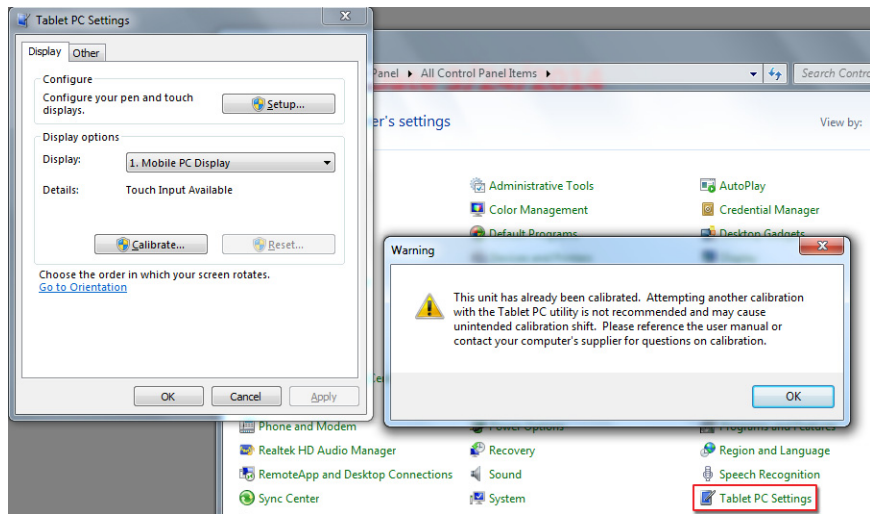
### Driver Software

The Microsoft touch screen driver is already loaded on the computer as part of the operating system. An alternate touch screen driver is also available for download at the Rockwell Automation Product Compatibility and Download Center (PCDC) at <https://compatibility.rockwellautomation.com/Pages/home.aspx>.

**TIP** If you must reinstall the touch screen driver, the touch screen utility automatically detects the USB port used by the touch screen controller.

## PCAP Touch Screen Technology

PCAP touch screens do not need any calibration. If you try to calibrate a PCAP touch screen through the Windows Tablet PC Settings, you receive a warning.



---

**IMPORTANT** PCAP touch screens are only on Tier 3 computer models. See [Computer Options on page 10](#) to see if your model is Tier 3.

---

## Resistive Technology

Resistive touch screens are activated when you apply pressure to the touch screen with your finger. You can operate a resistive touch screen while wearing gloves.

Resistive touch screens accept only single finger input. Multi-finger input or 'palm contact' can cause an incorrect touch input.



**ATTENTION:** Do not use sharp instruments to activate the touch screen. Scratching the surface of the touch screen can damage the display.

---

**IMPORTANT** Resistive touch screens are only on Tier 2 computer models. See [Computer Options on page 10](#) to see if your model is Tier 2.

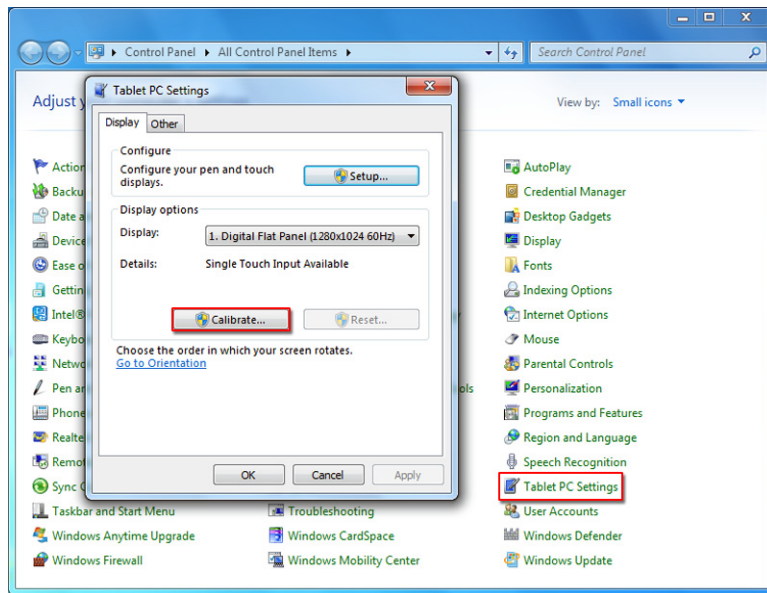
---

## Calibrate the Resistive Touchscreen

The resistive touch screen supplied with the computer is factory installed and calibrated.

Perform the following steps to recalibrate the touch screen.

1. From the Windows control panel menu, select Tablet PC Settings.
2. On the Display tab of Tablet PC Settings, click Calibrate.
3. Follow the calibration instructions on the touch screen.



**Notes:**



## Clean the Computer

| Topic              | Page |
|--------------------|------|
| Clean the Computer | 97   |

### Clean the Computer

To maintain your computer, it is important to clean the display, heat sink and vent holes, and to remove grease or paint.

**IMPORTANT** 6181P computer bezels resist the following chemicals:

- Alcohol (methyl or ethyl)
- Cleaning naphtha
- Commercial glass cleaners
- Ammonia (10% dilute solution)
- Oil (hydraulic or motor)
- Diesel fuel
- Gasoline (unleaded)
- Antifreeze mixtures (such as ethylene glycol)
- Automatic transmission fluid

### Clean the Integrated Display

Perform the following steps to clean the display.

1. Disconnect power from the computer at the power source.



**ATTENTION:** If the computer has a touch screen, it is possible for screen objects to activate during equipment wash-downs when the computer is turned on.

2. Clean the display with a mild soap with a clean sponge or a soft cloth.



**ATTENTION:** Use of abrasive cleansers or solvents can damage the display window. Do not scrub or use brushes.  
High-pressure washes can also damage the front bezel and gaskets.

3. Dry the display with a chamois or moist cellulose sponge to avoid water spots.

### Clean the Fan (Intel Core i7 models)

Perform the following steps to clean the fan.

1. Disconnect power from the computer at the power source.
2. Vacuum dust and debris out of the fan.

### Clean the Heat Sink and Vent Holes

Perform the following steps to clean the chassis.

1. Disconnect power from the computer at the power source.
2. Disconnect all peripheral devices from the computer.
3. Vacuum dust and debris from the heat sink and vent holes.

### Remove Paint and Grease from Bezel

Perform the following steps to remove paint and grease from the bezel of computers properly mounted in NEMA Type 4/4X or IEC IP66 enclosures.

1. Close and lock the access cover on the front bezel.

---

**IMPORTANT** Step 1 does not apply to computers with a stainless steel bezel.

---

2. Remove paint splashes and grease by rubbing lightly with isopropyl alcohol.



**ATTENTION:** Make sure the isopropyl alcohol does not come in contact with the equipment labels. Alcohol can cause the label printing to smear.

---

3. Use a mild soap or detergent solution to remove residue.
4. Rinse with clean water.

## Install Accessories

| Topic                      | Page |
|----------------------------|------|
| Available Accessories      | 99   |
| Pre-installation Checklist | 99   |
| Install an Add-in Card     | 100  |
| Install Additional Memory  | 104  |

### Available Accessories

You can view a list of accessories and replacement parts at <http://ab.rockwellautomation.com/Computers/Integrated-Display-Computers/Bulletin-6181#selection>.

Review the specifications of a new component before you install it to verify that it is compatible with the computer. Record the model, serial number, and any other pertinent information of new components for future reference.

---

**IMPORTANT** We recommend that you use only Allen-Bradley® approved accessories.

---

### Pre-installation Checklist

Review the following information before installing any accessories.

- [Voltage Precautions on page 41](#)
- [Electrostatic Discharge Precautions on page 42](#)

## Install an Add-in Card

Display and non-display computers support half-length, full-height add-in cards. Half-length PCI/PCIe cards are 106.68 mm (4.2 in.) high by 175.26 mm (7.0 in.) long.

The following table lists PCI/PCIe slots and configurations supported by the display and non-display computers.

| Computer Model              | Default One-slot Configuration | Alternate One-slot Using PCI Riser Kit (Cat. No. 6189V-PCIR) | Alternate Two-slot Using PCI/PCIe Extender Kit (Cat. No. 6189V-EXTPCI2)                                     |
|-----------------------------|--------------------------------|--|---|
| All display and non-display | 1 PCI Express x8               | 1 PCI  | <ul style="list-style-type: none"> <li>• 2 PCI</li> <li>• 2 PCIe x4</li> <li>• 1 PCIe x4 + 1 PCI</li> </ul> |

Any PCI/PCIe configuration supports 12 W (maximum) internal to the PCI/PCIe slot and 28 W (maximum) external to the computer, for a maximum load of 40 W. Verify that your card does not exceed its thermal ratings.

When the computer is running at its maximum rated temperature, the ambient temperature in the PCI/PCIe slot operating with a 4 W fanless card can reach 70 °C (158 °F). With a 12 W load, the ambient temperature can reach 90 °C (194 °F). Your PCI/PCIe slot temperatures can be lower based on the power usage of your specific application.



**ATTENTION:** Add-in cards are sensitive to ESD and require careful handling:

- Hold cards only by the edges.
- Do not touch the card connectors, components, or circuits.
- After removing an add-in card, place it on a flat, static-free surface, component side up.
- Do not slide the card over any surface.

**IMPORTANT** Use an antistatic wriststrap connected to the work surface, and properly grounded tools and equipment.

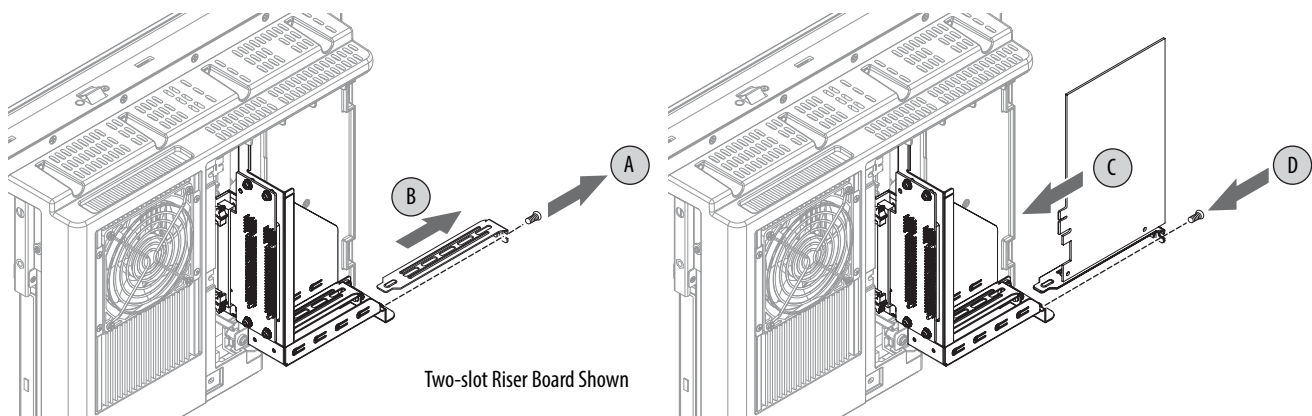
Follows these steps to install an add-in card (an integrated display computer is shown).

1. Follow the steps for [Pre-configuration on page 42](#).
2. Remove the computer cover as detailed in [Remove the Cover on page 43](#).
3. Remove the screw that secures the slot cover (A).
4. Pull out the slot cover (B) and store it.



**ATTENTION:** Do not discard the slot cover. If the add-in card is removed in the future, the slot cover must be reinstalled to maintain proper cooling.

5. Remove the add-in card from its protective packaging.
6. Slide the add-in card into a compatible riser board slot (C).  
Press to make sure it is firmly seated in the slot.
7. Secure the add-in card with the screw (D).



8. Connect any necessary cables to the add-in card.
9. Refer to any installation instructions that came with the add-in card to verify that all installation steps are followed.
10. Reinstall the computer cover as detailed in [Remove the Cover on page 43](#).
11. Follow the steps for [Post-configuration on page 43](#).

## PCI/PCIe Riser Board Options

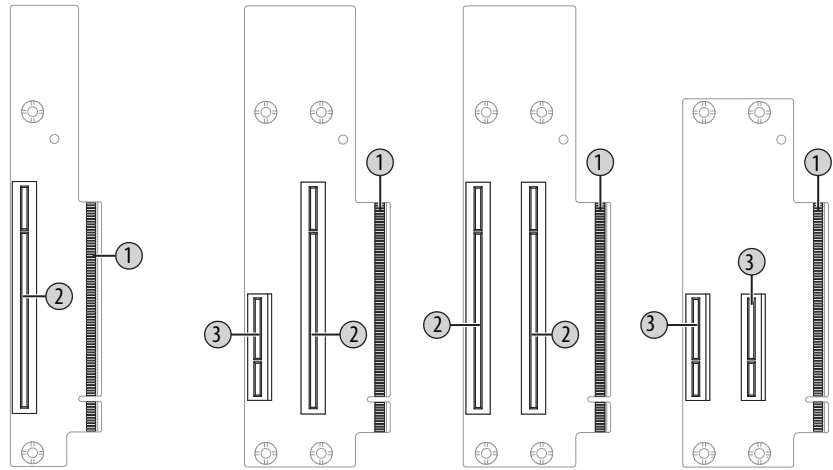
You can use the PCI/PCIe expansion slot kit, catalog number 6189V-EXTPCI2, to change the default one-slot PCI/PCIe riser board to the following:

- Two-slot PCI riser board
- Two-slot PCIe x4 riser board
- Two-slot riser board with one PCI slot and one PCIe x4 slot

**Figure 19 - PCI/PCIe Riser Board Options**

One-slot PCI Riser Kit,  
Cat. No. 6189V-PCIR

Alternate Two-slot PCI/PCIe Extender Kit, Cat. No. 6189V-EXTPCI2



| Item | Component              |
|------|------------------------|
| 1    | Motherboard connector  |
| 2    | PCI expansion slot     |
| 3    | PCIe x4 expansion slot |

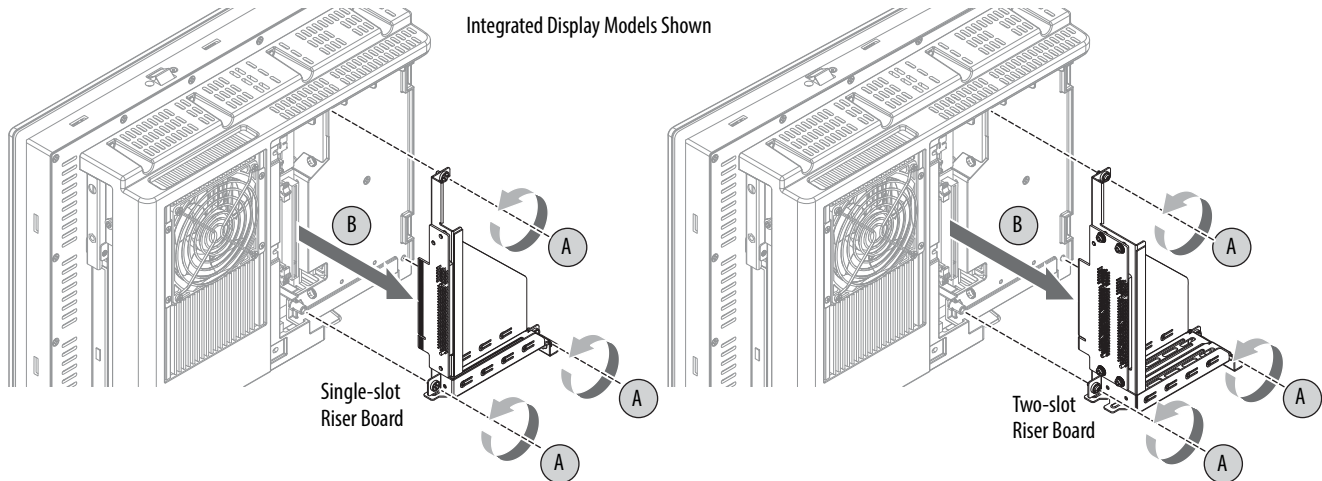
Follow these steps to install the PCI/PCIe expansion slot kit (the display computer is shown).



**SHOCK HAZARD:** Electrostatic discharge (ESD) can damage the computer and components. Read and follow [Electrostatic Discharge Precautions on page 42](#) before removing the rear cover.

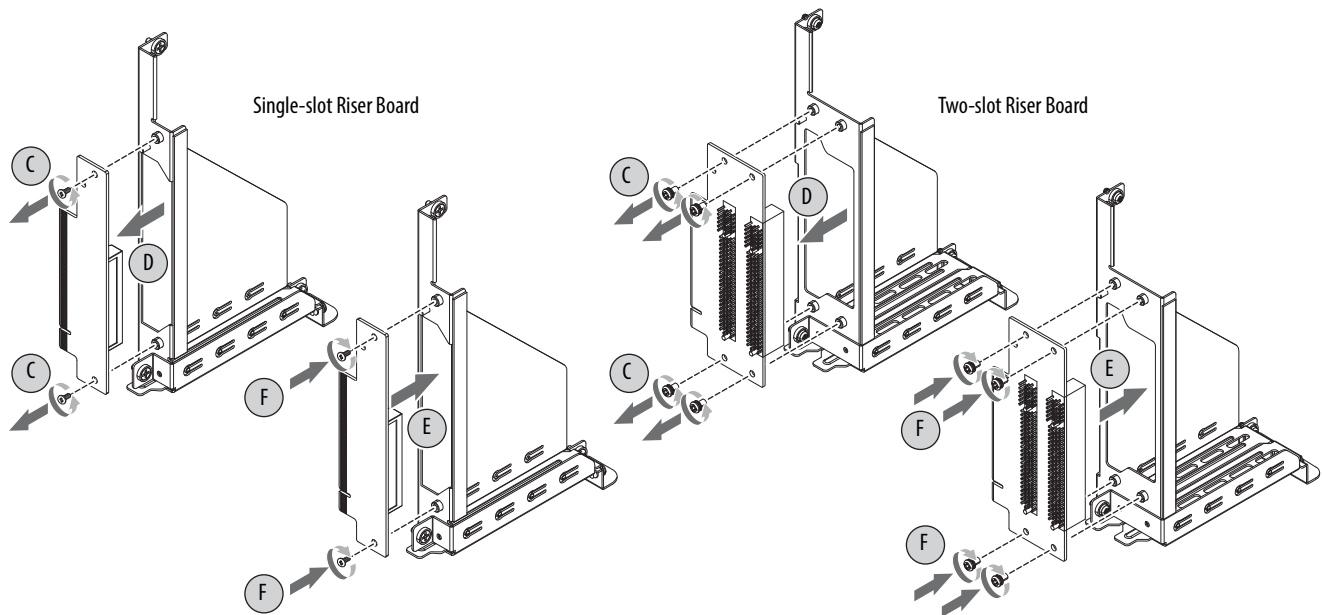
Failure to follow proper safety precautions could result in severe electrical shock or damage to the computer.

1. Follow the steps for [Pre-configuration on page 42](#).
2. Remove the computer cover as detailed in [Remove the Cover on page 43](#).
3. Remove the three screws that secure the default PCIe x8 riser board bracket (A).
4. Remove the PCIe x8 riser board assembly from the chassis (B).



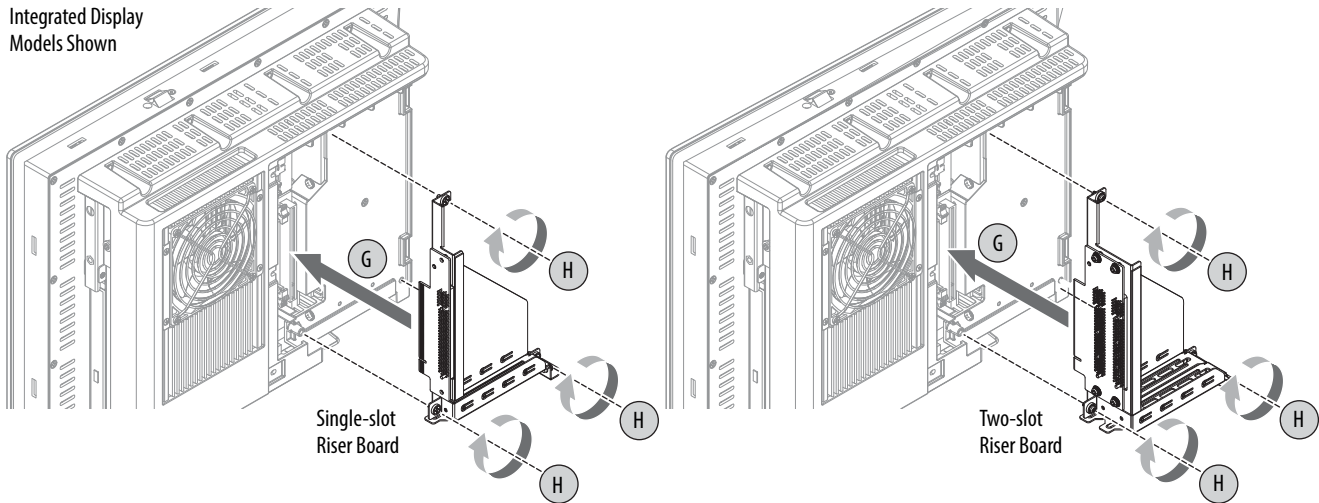
5. Remove the screws that secure the default riser board (C).
6. Remove the riser board from its bracket (D).
7. Place the default riser board with its screw on a static-dissipating work surface or inside an antistatic bag.
8. Hold the new riser board by its edge and remove it from its protective packaging.
9. Align the new riser board with the PCI/PCIe riser board bracket (E).
10. Secure it with the screws provided with the kit (F).

| If you are installing     | Then use   | Secure it with |
|---------------------------|--|----------------|
| A two-slot riser board    | The PCI/PCIe riser bracket provided with the kit | Four screws    |
| A single-slot riser board | The default PCI/PCIe riser bracket               | Two screws     |



11. Insert the riser board connector in the onboard expansion slot making sure the board is properly seated in the slot (G).
12. Tighten the three screws to secure the PCI/PCIe riser board assembly to the chassis (H).

Integrated Display Models Shown



**IMPORTANT** Make sure the mounting bracket does not pinch any cables under the bracket.

| If you intend to install            | Then  |
|-------------------------------------|---|
| A compatible add-in card <b>now</b> | Proceed to <a href="#">page 100</a> for instructions.   |
| An add-in card <b>later</b>         | <ol style="list-style-type: none"> <li>1. Reinstall the rear cover.</li> <li>2. Apply power to the computer.</li> </ol> |

13. Reinstall the computer cover as detailed in [Reinstall the Cover on page 44](#).
14. Follow the steps for [Post-configuration on page 43](#).

## Install Additional Memory

The motherboard of the integrated display computers has two SO-DIMM slots that support up to 16 GB maximum system memory.

See [Replace or Add Memory Modules on page 47](#) for further information on installing additional memory.



## Numerics

- 1450R**
  - product dimensions 25, 26
- 750R**
  - product dimensions 25, 26

## A

- accessories** 41
- add-in cards**
  - PCI expansion slot kit options 102
  - riser board options 102
- audio jacks**
  - in non-display computers 12
  - in performance computers 13

## B

- BIOS Setup utility** 55
  - access 56
  - Setup screen 56

## C

- calibrating touch screen** 95
- cleaning the computer**
  - chassis 98
  - display 97, 98
  - paint/grease marks 98
- CMOS clear** 91
- CompactFlash card**
  - slot locations 44
- component replacement**
  - CompactFlash card 44
- configuration tools**
  - installation 27

## D

- DC power**
  - connect 34
- diagnostic utility**
  - usage 78
- DIMM slots**
  - install memory 48
- display**
  - cleaning precautions 97, 98
- display, cleaning** 97

## E

- Ethernet connection** 36

## F

- features**
  - system boards 14
- Firmware Configuration**
  - Advanced 60
  - Boot 75
  - Chipset 72
  - Main 59
  - Save & Exit 77
  - Security 76
- functional ground screw** 35

## H

- hard disk drive**
  - precautions 45
  - removal 45
  - replace 99
- hardware diagnostics** 87
- hardware features**
  - non-display 12
  - performance 13, 14, 15
  - system boards 14
- hardware monitor** 87

## I

- I/O connections** 32
- installation**
  - connect peripherals 32
  - connect to LAN 36
  - environment and enclosure notice 20
  - guidelines 21
  - product dimensions 23
  - required tools 27

## L

- LAN connection** 36

## M

- maintenance**
  - clean the computer 97
  - cleaning display 97
- memory**
  - installation guidelines 48
  - installation precautions 47
- mounting**
  - panel mounting 29

**P****panel mounting**

- guidelines 27
- panel cutout 28

**parts list** 19**PCI Expansion Slot Kit**

- install 102

**peripherals**

- connect 32

**POST, see Power On Self Test****power**

- DC 34
- functional ground screw 35

**Power On Self Test****power supply unit (PSU)**

- replace 51

**product dimensions**

- 1200P display, performance 23
- 1200P non-display 23
- 1500P display, performance 24
- 1700P display, performance 25, 26

**R****rear cover**

- install, performance/non-display 44
- remove, performance/non-display 43

**replace components**

- post-configuration procedure 43
- pre-configuration procedure 42

**replacement parts** 41**RTC battery**

- estimated life span 49

**S****Setup menu**

- AMI Rescue 80
- Diagnostics 78
- Exit 85
- Firmware Configuration 58
- Firmware Update 57

**shut down procedure** 39**system**

- defaults 90

**system views**

- non-display, bottom 12
- non-display, rear 12
- non-display, sides 12
- performance, front 13, 14, 15
- performance, rear 13, 14, 15
- performance, sides 13, 14, 15

**T****touch screen**

- calibrating 95
- serial port 93
- type 94

**touchscreen**

- driver software 93

**troubleshooting**

- clearing CMOS 91
- diagnostic utility 89
- hardware monitor 87
- load system defaults 90
- procedure 56, 88

**U****unpacking reminders** 19



## Rockwell Automation Support

Use the following resources to access support information.

|   |   |   |
|---|---|---|
| <b>Technical Support Center</b>                         | Knowledgebase Articles, How-to Videos, FAQs, Chat, User Forums, and Product Notification Updates.                     | <a href="https://rockwellautomation.custhelp.com/">https://rockwellautomation.custhelp.com/</a>   |
| <b>Local Technical Support Phone Numbers</b>            | Locate the phone number for your country.   | <a href="http://www.rockwellautomation.com/global/support/get-support-now.page">http://www.rockwellautomation.com/global/support/get-support-now.page</a>         |
| <b>Direct Dial Codes</b>                                | Find the Direct Dial Code for your product. Use the code to route your call directly to a technical support engineer. | <a href="http://www.rockwellautomation.com/global/support/direct-dial.page">http://www.rockwellautomation.com/global/support/direct-dial.page</a>                 |
| <b>Literature Library</b>                               | Installation Instructions, Manuals, Brochures, and Technical Data.  | <a href="http://www.rockwellautomation.com/global/literature-library/overview.page">http://www.rockwellautomation.com/global/literature-library/overview.page</a> |
| <b>Product Compatibility and Download Center (PCDC)</b> | Get help determining how products interact, check features and capabilities, and find associated firmware.            | <a href="http://www.rockwellautomation.com/global/support/pcdc.page">http://www.rockwellautomation.com/global/support/pcdc.page</a>                               |

## Documentation Feedback

Your comments will help us serve your documentation needs better. If you have any suggestions on how to improve this document, complete the How Are We Doing? form at [http://literature.rockwellautomation.com/idc/groups/literature/documents/du/ra-du002\\_-en-e.pdf](http://literature.rockwellautomation.com/idc/groups/literature/documents/du/ra-du002_-en-e.pdf).

Rockwell Automation maintains current product environmental information on its website at <http://www.rockwellautomation.com/rockwellautomation/about-us/sustainability-ethics/product-environmental-compliance.page>.

Allen-Bradley, Rockwell Software, and Rockwell Automation are trademarks of Rockwell Automation, Inc.

Trademarks not belonging to Rockwell Automation are property of their respective companies.

Rockwell Otomasyon Ticaret A.Ş., Kar Plaza İş Merkezi E Blok Kat:6 34752 İçerenköy, İstanbul, Tel: +90 (216) 5698400

**[www.rockwellautomation.com](http://www.rockwellautomation.com)**

### Power, Control and Information Solutions Headquarters

Americas: Rockwell Automation, 1201 South Second Street, Milwaukee, WI 53204-2496 USA, Tel: (1) 414.382.2000, Fax: (1) 414.382.4444

Europe/Middle East/Africa: Rockwell Automation NV, Pegasus Park, De Kleetlaan 12a, 1831 Diegem, Belgium, Tel: (32) 2 663 0600, Fax: (32) 2 663 0640

Asia Pacific: Rockwell Automation, Level 14, Core F, Cyberport 3, 100 Cyberport Road, Hong Kong, Tel: (852) 2887 4788, Fax: (852) 2508 1846

Publication 6181P-UM003B-EN-P - August 2017

Supersedes Publication 6181P-UM003A-EN-P - May 2014

Copyright © 2017 Rockwell Automation, Inc. All rights reserved. Printed in the U.S.A.