

SIEMENS

ULTRAMAT 23

Gas Analyzers for IR-absorbing Gases and Oxygen

7MB2335, 7MB2337, 7MB2338

Operating Instructions

02/01



ULTRAMAT 23 gas analyzer, benchtop unit



ULTRAMAT 23 gas analyzer, 19" rack

The reproduction, transmission or use of this document or its contents is not permitted without express written authority. Offenders will be liable for damages. All rights created by the granting of patents or registration of a design are reserved. Technical data subject to change without notice

Weitergabe sowie Vervielfältigung dieser Unterlage, Verwertung und Mitteilung ihres Inhaltes nicht gestattet, soweit nicht ausdrücklich zugestanden.
Zu widerhandlungen verpflichtet zu Schadenersatz. Alle Rechte vorbehalten, insbesondere für den Fall der Patenterteilung oder GM-Eintragung. Technische Änderungen vorbehalten.

Toute communication ou reproduction de ce document, toute exploitation ou communication de son contenu sont interdites, sauf autorisation expresse. Tout manquement à cette règle est illicite et expose son auteur au versement de dommages et intérêts. Tous nos droits sont réservés pour le cas de la délivrance d'un brevet ou celui de l'enregistrement d'un modèle d'utilité. Modifications techniques sont réservées

La divulgación y reproducción de este documento así como el aprovechamiento de su contenido, no están autorizados, a no ser que se obtenga el consentimiento expreso, para ello. Los infractores quedan obligados a la indemnización por daños y perjuicios. Se reservan todos los derechos, en particular para el caso de concesión de Patente o de Modelo de Utilidad.
Salvo modificaciones técnicas

La trasmissione a terzi e la riproduzione di questa documentazione, cosiccome lo sfruttamento del suo contenuto non è permesso, se non autorizzato per iscritto. Le infrazioni comporteranno una richiesta di danni. Tutti i diritti sono riservati, in particolare nel caso di brevetti. Modifiche tecniche possibili.

ULTRAMAT, OXYMAT, SIPAN are Siemens registered trademarks. All other product or system names are (registered) trademarks of their respective owners and must be treated accordingly. According to the German law on units in measuring technology, data in inches only apply to devices for export.

ULTRAMAT, OXYMAT, SIPAN sind Marken der Siemens. Die übrigen Bezeichnungen in diesem Handbuch können Marken sein, deren Benutzung durch Dritte für deren Zwecke die Rechte der Inhaber verletzen können. Die Angaben in Zoll (inch) gelten gemäß dem Gesetz über Einheiten im Meßwesen" nur für den Export.

ULTRAMAT, OXYMAT, SIPAN sont des marques déposées de Siemens. D'autres dénominations utilisées dans ce document peuvent également être des marques déposées dont l'utilisation par des tiers à leurs propres fins peut enfreindre les droits des propriétaires desdites marques.

ULTRAMAT, OXYMAT, SIPAN son marcas registradas de Siemens. Las otras designaciones que figuran en este documento pueden ser marcas cuya utilización por terceros para sus propios fines puede violar los derechos de los propietarios de dichas marcas. Conforma a la "Ley sobre las unidades de medida", las dimensiones en pulgadas sólo son válidas para la exportación.

ULTRAMAT, OXYMAT, SIPAN sono marchi registrati Siemens. Le denominazioni di altri prodotti menzionati in questa documentazione possono essere marchi il cui uso da parte di terzi può violare i diritti di proprietà. Conformemente alla "Legge sulle unità di misura" i dati in pollici valgono soltanto per l'esportazione.

Contents

1	Information for the User	1-1
1.1	General Information	1-2
1.2	Notes on Using this Manual	1-3
1.3	Danger Information	1-3
1.4	Approved Use	1-4
1.5	Qualified Personnel	1-4
1.6	Warranty Information	1-5
1.7	Supply and Delivery	1-5
1.8	Standards and Regulations	1-5
1.9	Declaration of Conformity	1-6
2	Installation Guidelines	2-1
2.1	Safety Information	2-2
2.2	Setting-up	2-2
2.3	Gas Connections and Internal Gas Paths	2-3
2.4	Gas Conditioning	2-3
2.5	Electric Connection	2-4
2.5.1	Power Supply Connection	2-5
2.5.2	Connection of Signal Cables	2-5
3	Technical Description	3-1
3.1	Application	3-2
3.2	Design, Characteristics	3-3
3.3	Special Characteristics	3-4
3.4	Measuring Principles	3-5
3.5	Connections	3-6
3.5.1	Pin Assignments	3-6
3.5.2	Internal Gas Paths, Gas Flow Diagrams	3-8
3.5.3	Installation and Connection Diagrams	3-10
3.5.4	Communication	3-12
3.6	Technical Data	3-14
3.7	Dimensions	3-15
3.8	Ordering Data	3-17
3.9	Documentation	3-23
3.10	Conditions of Sale and Delivery	3-24
4	Start-up	4-1
4.1	Safety Information	4-2
4.2	Preparations for Start-up	4-2
4.3	Start-up	4-3
4.3.1	AUTOCAL	4-3
4.3.2	Calibration	4-4
4.3.3	System Setup with Several Analyzers in Parallel	4-5

5	Operation	5-1
5.1	General	5-3
5.2	Display and Input Panel	5-4
5.3	Warm-up Mode	5-7
5.4	Measuring Mode	5-8
5.5	Input Mode	5-8
5.5.1	Code Levels	5-9
5.5.2	Key Operations Step-by-step	5-10
5.5.3	Using the ESC key	5-12
5.6	Recoding the Analyzer	5-13
5.7	Analyzer Status	5-15
5.7.1	Analyzer Status: Status	5-15
5.7.1.1	Analyzer Status: Status: Logbook/Faults	5-15
5.7.1.2	Analyzer Status: Status: Maintenance Request	5-16
5.7.1.3	Analyzer Status: Status: AUTOCAL Deviation	5-16
5.7.1.4	Analyzer Status: Status: O2 Sensor Status	5-16
5.7.2	Analyzer Status: Diagnostic Values	5-17
5.7.2.1	Analyzer Status: Diagnostic Values: IR Diagnostic Values	5-17
5.7.2.2	Analyzer Status: Diagnostic Values: O2 Diagnostic Values	5-17
5.7.2.3	Analyzer Status: Diagnostic Values: Pressure Sensor Diagnosis	5-18
5.7.2.4	Analyzer Status: Diagnostic Values: Other Diagnostic Values	5-18
5.7.3	Analyzer Status: Factory Settings Hardware	5-19
5.7.4	Analyzer Status: Factory Settings Software	5-19
5.8	Calibration	5-21
5.8.1	Calibration: Calibrate IR Channels	5-21
5.8.1.1	Calibration: Calibrate IR Channels: Set Span Gas Values	5-21
5.8.1.2	Calibration: Calibrate IR Channels: Start with Range MR 1/2	5-22
5.8.2	Calibration: Calibrate O2 Sensor	5-22
5.8.2.1	Calibration: Calibrate O2 Sensor: O2 Cal. after Install	5-22
5.8.2.2	Calibration: Calibrate O2 Sensor: O2 Zero Cal.	5-23
5.8.3	Calibration: Calibrate Pressure Sensor	5-23
5.8.4	Calibration: AUTOCAL	5-24
5.9	Parameters	5-26
5.9.1	Parameters: Measuring Ranges	5-26
5.9.1.1	Parameters: Measuring Ranges: Switch Ranges	5-26
5.9.1.2	Parameters: Measuring Ranges: Change Ranges	5-26
5.9.1.3	Parameters: Measuring Ranges: Hysteresis	5-27
5.9.2	Parameters: Limit values	5-27
5.9.3	Parameters: Time Constants	5-28
5.9.4	Parameters: Pump/LCD Contrast	5-29
5.9.4.1	Parameters: Pump/LCD Contrast: Adjust Pump	5-29
5.9.4.2	Parameters: Pump/LCD Contrast: Adjust LCD Contrast	5-30
5.10	Configuration	5-33
5.10.1	Configuration: Inputs/Outputs/Pump	5-33
5.10.1.1	Configuration: Inputs/Outputs/Pump: Analog Outputs	5-33
5.10.1.2	Configuration: Inputs/Outputs/Pump: Assign Relays	5-34
5.10.1.3	Configuration: Inputs/Outputs/Pump: Binary/Sync Inputs	5-37
5.10.1.4	Configuration: Inputs/Outputs/Pump: Pump at CAL/MEAS	5-38

5.10.2	Configuration: Special Functions	5-38
5.10.2.1	Configuration: Special Functions: Codes/Language	5-38
5.10.2.2	Configuration: Special Functions: AUTOCAL Drift	5-39
5.10.2.3	Configuration: Special Functions: ELAN/PROFIBUS	5-40
5.10.2.4	Configuration: Special Functions: Factory Data/Reset/Units	5-42
5.10.3	Configuration: Tests	5-43
5.10.3.1	Configuration: Tests: Display/Keys/Flow	5-43
5.10.3.2	Configuration: Tests: Inputs/Outputs	5-43
5.10.3.3	Configuration: Tests: Chopper/IR Source	5-45
5.10.3.4	Configuration: Tests: RAM Monitor	5-45
5.10.4	Configuration: Factory Configuration	5-45
5.11	Other Inputs	5-46
5.11.1	PUMP Key	5-46
5.11.2	CAL Key	5-46
6	Maintenance	6-1
6.1	Messages	6-2
6.1.1	Maintenance Requests	6-2
6.1.2	Fault Messages	6-3
6.2	Maintenance Work	6-6
6.2.1	Replacement of O ₂ Sensor	6-7
6.2.2	Replacement of Fuse	6-7
6.2.3	Replacement of Safety Filter	6-8
6.2.4	Emptying the Condensation Trap	6-8
6.2.5	Replacement of Coarse Filter	6-9
6.3	Maintenance of Gas Path	6-8
6.4	Cleaning the Analyzer	6-9
7	Spare Parts List	7-1
8	Appendix	8-1
8.1	Returned Deliveries	8-2
8.1.1	Addresses for Returned Deliveries	8-2
8.2	Explanations	8-4
8.2.1	Abbreviations	8-4
8.2.2	Explanation of Symbols	8-4
8.3	Software Release Versions	8-5

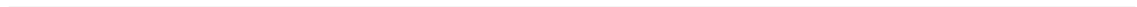

Information for the User

1

1.1	General Information	1-2
1.2	Notes on Using this Instructions	1-3
1.3	Danger Information	1-3
1.4	Approved Use	1-4
1.5	Qualified Personnel	1-4
1.6	Warranty Information	1-5
1.7	Supply and Delivery	1-5
1.8	Standards and Regulations	1-5
1.9	Declaration of Conformity	1-6

Dear Customer,

Please read this Manual before you start work!

It contains important information and data whose observance will guarantee correct functioning of the analyzer and also save you servicing costs. The information will significantly help you when using the equipment and will lead to reliable results.



Notice

We recommend that you discuss your application with our specialist department, especially before using the analyzer for new applications, for example in research and development.

1.1 General Information

The product described in this instructions has left the factory in a perfect and tested condition as regards safety. In order to retain this state and to achieve correct and safe operation of this product, it must only be used in the manner described by the manufacturer. In addition, correct and safe operation of this product is dependent on proper transport, storage and installation as well as careful operation and maintenance.

This instructions contains the information required for approved use of the product described in it. The instructions has been prepared for technically qualified personnel who have been specially trained or who possess appropriate knowledge in the field of instrumentation and control, referred to further as automation technology.

Knowledge of the safety information and warnings present in this instructions and their technically correct implementation are prerequisites for danger-free installation and commissioning and for safety during operation and maintenance of the described product. Only a qualified person possesses the required specialist knowledge to correctly interpret the general safety information and warnings present in this instructions and to apply them to the specific case.

This instructions is included in the delivery of the analyzer, even if separate ordering has been made possible for logistic reasons. For clarity reasons this instructions cannot cover all possible details for all versions of the described product and cannot describe every possible case in connection with installation, operation, maintenance or the use in systems. Should you require further information, or should particular problems occur which are not handled in sufficient depth in this instructions, help can be requested through your local Siemens office or representative. Please refer to Chapter 3 of this instructions for a list of Siemens offices and representatives.

1.2 Notes on Using this Instructions

This instructions describes the applications of the equipment and how you can start it up, operate and service it.

Of particular importance are the **warning and information texts**. These are separated from the remaining text, specially identified by appropriate pictograms (see Section 1.3).

1.3 Danger Information

Safety information and warnings serve to prevent danger to the life and health of users or maintenance personnel or to prevent damage to property and are emphasized in this instructions by the terms defined here. They are additionally identified by warning symbols (pictograms). The terms used in this instructions and the information on the product itself have the following meaning:



Danger

means that death, severe personal injury and/or substantial damage to property **will occur** if the appropriate safety precautions are not observed.



Warning

means that death, severe personal injury and/or substantial damage to property **can occur** if the appropriate safety precautions are not observed.



Caution

with warning triangle means that slight personal injury **can occur** if the appropriate safety precautions are not observed.

Caution

without warning triangle means that damage to property **can occur** if the appropriate safety precautions are not observed.

Attention

means that an undesirable event or state can occur if the appropriate safety precautions are not observed.



Notice

is important information on the product itself, the handling of the product or the respective part of the instructions to which particular attention should be paid.

1.4 Approved Use

Approved use in the sense of this instructions means that this product may only be used for the applications described in the Catalog and in the Technical Description (see also Chapter 3 of this instructions) and only in conjunction with other devices and components which have been recommended or approved of by Siemens.

The product described in this instructions has been developed, manufactured, tested and documented taking into account the appropriate safety standards. No danger therefore exists in the normal case with respect to damage to property or the health of persons if the handling guidelines and safety information described for configuring, assembly, approved use and maintenance are observed. This device has been designed such that safe isolation is guaranteed between the primary and secondary circuits. Low voltages which are connected must also be generated using safe isolation.

Correct and safe operation of this analyzer is additionally dependent on proper transport, storage, installation and assembly, as well as careful operation and maintenance.



Warning

This analyzer is an electrical unit. Following removal of the housing or guard, or after opening the system cabinet, certain parts of the device/system are accessible which may carry dangerous voltages. Therefore only suitably qualified personnel may work on this device. These must be thoroughly acquainted with all sources of danger and the maintenance measures as described in this instructions.

1.5 Qualified Personnel

Severe personal injury and/or extensive damage to property may occur following unqualified work on the device/system or the failure to observe the warnings described in the instructions or on the device/system cabinet. Therefore only suitably qualified personnel may work on this device/system.

Qualified persons in the sense of the safety information present in this instructions or on the product itself are persons who

- are either familiar as configuring engineers with the safety concepts of automation technology
- or have been trained as operators in the use of automation technology equipment and are acquainted with the contents of this instructions which refer to operation
- or have been appropriately trained as commissioning and/or maintenance personnel for such automation technology equipment or are authorized to energize, ground and tag circuits and devices/systems in accordance with established safety practices.

1.6 Warranty Information

Your attention is drawn to the fact that the contents of this instructions are not part of a previous or existing agreement, commitment or statutory right and do not change these. All commitments on the part of Siemens are contained in the respective sales contract which also contains the complete and solely applicable warranty conditions. These warranty conditions in the contract are neither extended nor limited by the contents of this instructions.

1.7 Supply and Delivery

The respective scope of delivery according to the valid contract is listed on the shipping documents accompanying the delivery.

When opening the packaging, please observe the corresponding information on the packaging material. Check that the delivery is complete and undamaged. In particular, compare the Order Nos. on the rating plates (if present) with the ordering data.

Please retain the packaging material if possible so that you can reuse it if it is necessary to return the device. A form for this purpose can be found in Chapter 8.1.

1.8 Standards and Regulations

The harmonized European standards have been applied as far as possible to the specification and production of this device. If no harmonized European standards have been applied, the standards and regulations for the Federal Republic of Germany apply (see also the technical data in Chapter 3).

When using this product outside the range of applicability of these standards and regulations, the appropriate standards and regulations in the country of use must be observed.

1.9 Declaration of Conformity

CE symbol



The ULTRAMAT 23 gas analyzer complies with the requirements of the EU guidelines listed below.

EMC guideline

The ULTRAMAT 23 gas analyzer complies with the requirements of the EU guideline 89/336/EEC "Electromagnetic compatibility".

The ULTRAMAT 23 gas analyzer is designed for use in industrial applications.

Field of use	Requirements for:	
	Emitted interference	Interference immunity
Industry	EN 50081-2: 1993	EN 50082-2: 1995

Low-voltage guideline

The ULTRAMAT 23 gas analyzer complies with the requirements of the EU guideline 72/23/EEC "Low-voltage guideline". Observation of this EU guideline is checked according to DIN EN 61010-1 (corresponds to IEC 61010-1).

Declaration of conformity

In line with the above-mentioned EU guidelines, the EU declarations of conformity are available at the following address for inspection by appropriate authorities:

Siemens Aktiengesellschaft
Automation and Drives Group
A&D PI 21/22
Östliche Rheinbrückenstraße 50

D-76187 Karlsruhe
Germany

Installation Guidelines

2

2.1	Safety Information	2-2
2.2	Setting-up	2-2
2.3	Gas Connections and Internal Gas Paths	2-3
2.4	Gas Conditioning	2-3
2.5	Electric Connection	2-4
2.5.1	Power Supply Connection	2-5
2.5.2	Connection of Signal Cables	2-5

2.1 Safety Information



Warning

Certain parts in this analyzer carry dangerous voltages. The housing must be closed and earthed before switching on the analyzer.



Warning

The analyzer must not be used in hazardous areas. Explosive gas mixtures (e.g. flammable gases together with air or oxygen in a potentially explosive ratio) must not be measured.

If the sample gas contains flammable components above the lower explosion limit, the required explosion protection measures must be approved of by an authorized inspector.



Warning

The gas path must be checked for leaks at regular intervals depending on the corrosivity, toxicity and flammability of the sample gas. When measuring toxic or corrosive gases, it may occur that sample gas collects within the analyzer as a result of leaks in the gas path. To prevent the danger of poisoning or the damaging of analyzer components, the analyzer or system must be purged with inert gas (e.g. nitrogen). The gas displaced by purging must be collected using an appropriate assembly and routed for environment-friendly disposal via an exhaust line.

2.2 Setting-up

- A location should be selected which is as free as possible from vibration. The permissible ambient temperature must be observed during operation.
- The ULTRAMAT 23 must be placed on supporting rails if it is to be fitted in a cabinet or benchtop housing. Assembly only at the front is insufficient because the weight of the analyzer would place too great a load on the chassis.
- The heat sink on the rear panel must be unrestricted to permit appropriate air circulation.

2.3 Gas Connections and Internal Gas Paths

Sample gas line	<p>A pipe with an outer diameter of 6 mm or 1/4" is present as the gas connection.</p> <p>Materials to be used: PE, FPM or PTFE.</p> <p>If the sample gas is to flow into a collective exhaust line, observe the following points:</p> <ul style="list-style-type: none"> • The exhaust line must be free of rapid changes in pressure. If this is not possible, either use a separate exhaust line or • fit a damping vessel (> 1 l) between the analyzer and the exhaust line. • The exhaust line should always be routed with a falling gradient since water make condense in it.
Paths for AUTO-CAL/zero gas	<p>The corresponding gases must be sucked in via a fine filter. The amount of the measured gas component must be negligibly small in the AUTOCAL gas (zero gas). In particular when carrying out an AUTOCAL for CO₂ ranges < 3 %, the air must be routed via a CO₂ absorber (e.g. soda lime).</p>
Path for chopper section purging	<p>With certain CO₂ ranges (see Section 3), the chopper section is purged with clean nitrogen or CO₂.free synthetic air at an inlet pressure of 3 to 3.5 bar.</p>
Gas connections and gas paths	<p>Refer to the Technical Description (Chapter 3) in this Manual.</p>

2.4 Gas Conditioning

The sample gas must be sufficiently conditioned to prevent contamination of the parts through which it flows. The ULTRAMAT 23 is usually preceded by

- a gas sampling device with filter,
- a sample gas cooler,
- an analysis filter (1–2 µm) and
- an external gas suction pump (with sample gas lines > 20 m)

(see Fig. 2.1).

Depending on the composition of the sample gas, additional equipment may be necessary such as e.g. a washbottle, additional filters and a pressure reducer.

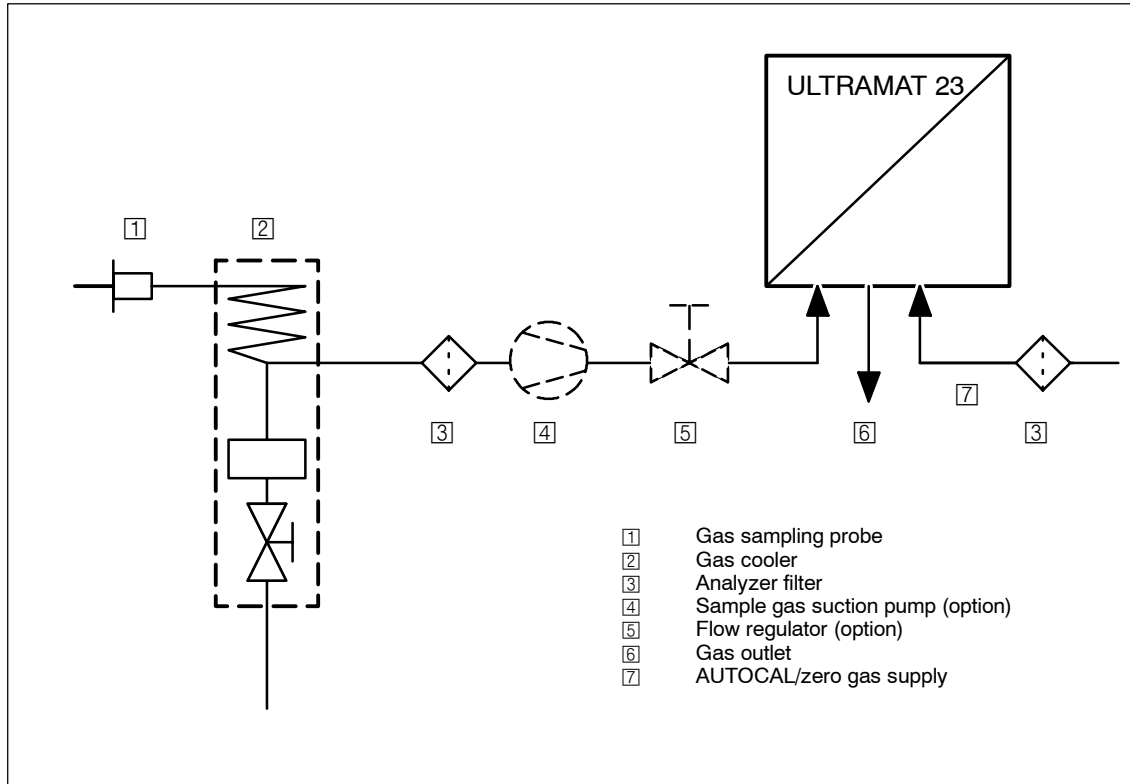

Fig. 2-1 Gas conditioning

2.5 Electric Connection



Warning

The following must be observed during the electric installation:

The country-specific standards for installation of power systems with rated voltages below 1000 V (in Germany: VDE 0100).

The failure to observe the standards may result in death, personal injury and/or damage to property.

2.5.1 Power Supply Connection

The analyzer is supplied with an appliance plug which may only be connected to the power supply by qualified personnel (see Section 1.5). The cross-section of the cable must be $\geq 1 \text{ mm}^2$, where the protective earth conductor must have at least the same cross-section as L and N.

The mains cable must be routed separately from the signal cables if it is not double-insulated.

A mains disconnecter which is readily accessible and identified as belonging to the analyzer must be provided in the immediate vicinity of the analyzer.

The benchtop version is already fitted with a mains disconnecter on the rear panel which must always remain readily accessible.

Check that the local mains voltage agrees with that specified on the rating plate on the analyzer.

2.5.2 Connection of Signal Cables

RC elements must be connected according to Fig. 2-2 as a measure to suppress the generation of sparks across the relay contacts (e.g. limit relays). Note that the RC element results in a drop-out delay for an inductive component (e.g. solenoid valve). The RC element should therefore be dimensioned according to the following rule-of-thumb:

$$R = R_L/2; C = 4L/R_L^2.$$

The following are usually sufficient: $R = 100 \Omega$ and $C = 200 \text{ nF}$.

Additionally make sure that you only use a non-polarized capacitor C.

When using direct current, it is possible to fit a spark suppression diode instead of the RC element.

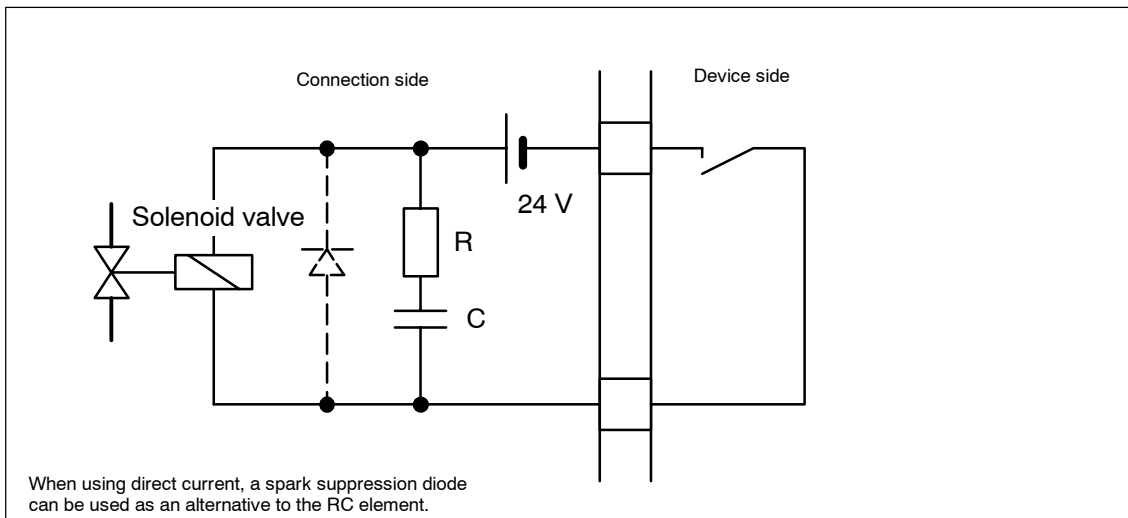

Fig. 2-2 Measure to suppress sparks on a relay contact

The reference ground of the analog inputs is the housing potential.

The analog outputs are floating, but have a common negative pole.

The input/output cables must be connected to the corresponding trapezoidal plug (SUB-D plug) according to the pin assignment diagrams (see Chapter 3, Technical Description, Fig. 3.5). The conductor cross-section should be $\geq 0.5 \text{ mm}^2$. The interface cable must not be longer than 500 m.



Notice

The cables (apart from the mains cable) must be screened, and their screen must be screen connected at both ends to ground.



Notice

The 24-V power supply must be a protective extra-low voltage with safe electrical isolation.

Technical Description

3

3.1	Application	3-2
3.2	Design, Characteristics	3-3
3.3	Special Characteristics	3-4
3.4	Measuring Principles	3-5
3.5	Connections	3-6
3.5.1	Pin Assignments	3-6
3.5.2	Internal Gas Paths, Gas Flow Diagrams	3-8
3.5.3	Installation and Connection Diagrams	3-10
3.5.4	Communication	3-12
3.6	Technical Data	3-14
3.7	Dimensions	3-15
3.8	Ordering Data	3-17
3.9	Documentation	3-23
3.10	Conditions of Sale and Delivery	3-24

3.1 Application

The **ULTRAMAT 23** gas analyzer can measure up to 4 gas components at once: A maximum of three infrared sensitive gases such as CO, CO₂, NO, SO₂, CH₄, R22 (Freon CHClF₂) plus O₂ with an electrochemical oxygen measuring cell.

ULTRAMAT 23 basic versions for:

- 1 infrared gas component with/without oxygen measurement
- 2 infrared gas components with/without oxygen measurement
- 3 infrared gas components with/without oxygen measurement

Specific applications:

The **ULTRAMAT 23** with 2 IR components without pump and with or without oxygen measurement is also available with two separate gas paths. This allows the measurement of two measuring points as used e.g. for the NO_x measurement before and after the NO_x converter.

The **ULTRAMAT 23** gas analyzer can be used in emission measuring systems and for process and safety monitoring.

TÜV-approved versions of the **ULTRAMAT 23** are available for measurement of CO, NO, SO₂ and O₂ according to 13. BImSchV and TA Luft.

Smallest TÜV-approved and permitted measuring ranges:

- 1- and 2-component analyzer
 - CO: 0 to 150 mg/m³
 - NO: 0 to 250 mg/m³
 - SO₂: 0 to 400 mg/m³
- 3-Komponenten-Analysator
 - CO: 0 to 250 mg/m³
 - NO: 0 to 400 mg/m³
 - SO₂: 0 to 400 mg/m³

All larger measuring ranges are also permitted.

For use in non-potentially explosive atmospheres.

Application examples

- Optimization of small firing systems
- Monitoring of exhaust gas concentration from firing systems with all types of fuel (oil, gas and coal) as well as operational measurements with thermal incineration plants
- Room air monitoring
- Monitoring of air in fruit stores, greenhouses, fermenting cellars and warehouses
- Monitoring of process control functions
- Atmosphere monitoring during heat treatment of steel.

Special characteristics

- Stable 19" sheet-steel enclosure for mounting in hinged bay or on slide rails.
Option: bench-top version with handles as well as condensation trap and coarse filter
- Operation based on NAMUR recommendation
- Simple, fast programming and commissioning of analyzer
- Practically maintenance-free as a result of AUTOCAL with ambient air (or with N₂ for analyzers without oxygen sensor); both the zero and the span are calibrated in the process
- Calibration with calibration gas is only necessary every six to 12 months, depending on application
- Large, backlit LCD for measured values; menu-based inputs for programming, test functions and calibration
- Two measuring ranges can be set per component within defined limits;
all measuring ranges linearized;
autoranging with range identification
- Automatic correction of variations in atmospheric pressure
- Gas flow monitoring;
Low-flow alarm at < 1 l/min
- Maintenance request alert
- Two limits can be freely configured for each component, for upward or downward violation
- Three binary inputs for sample gas pump on/off, triggering of AUTOCAL and synchronization of several devices
- Eight relay outputs can be freely configured for fault, maintenance request, maintenance switch, limits, range identification, external solenoid valves
- Four electrically isolated analog outputs;
RS 485 present in basic device;
option: converter to RS 232
- Incorporation in networks via PROFIBUS-DP/-PA interface
- SIPROM GA software as service and maintenance tool
- Eight additional relay outputs as an option
- Eight additional binary outputs as an option.

3.2 Design, Characteristics

ULTRAMAT 23 also available as bench-top unit:

- 2 handles on top cover
- 4 rubber feet for setting up
- No mounting frame

Fitted inside analyzer:

- Safety condensation trap
- Barometric sensor
- Sample gas pump (option)
- Safety filter

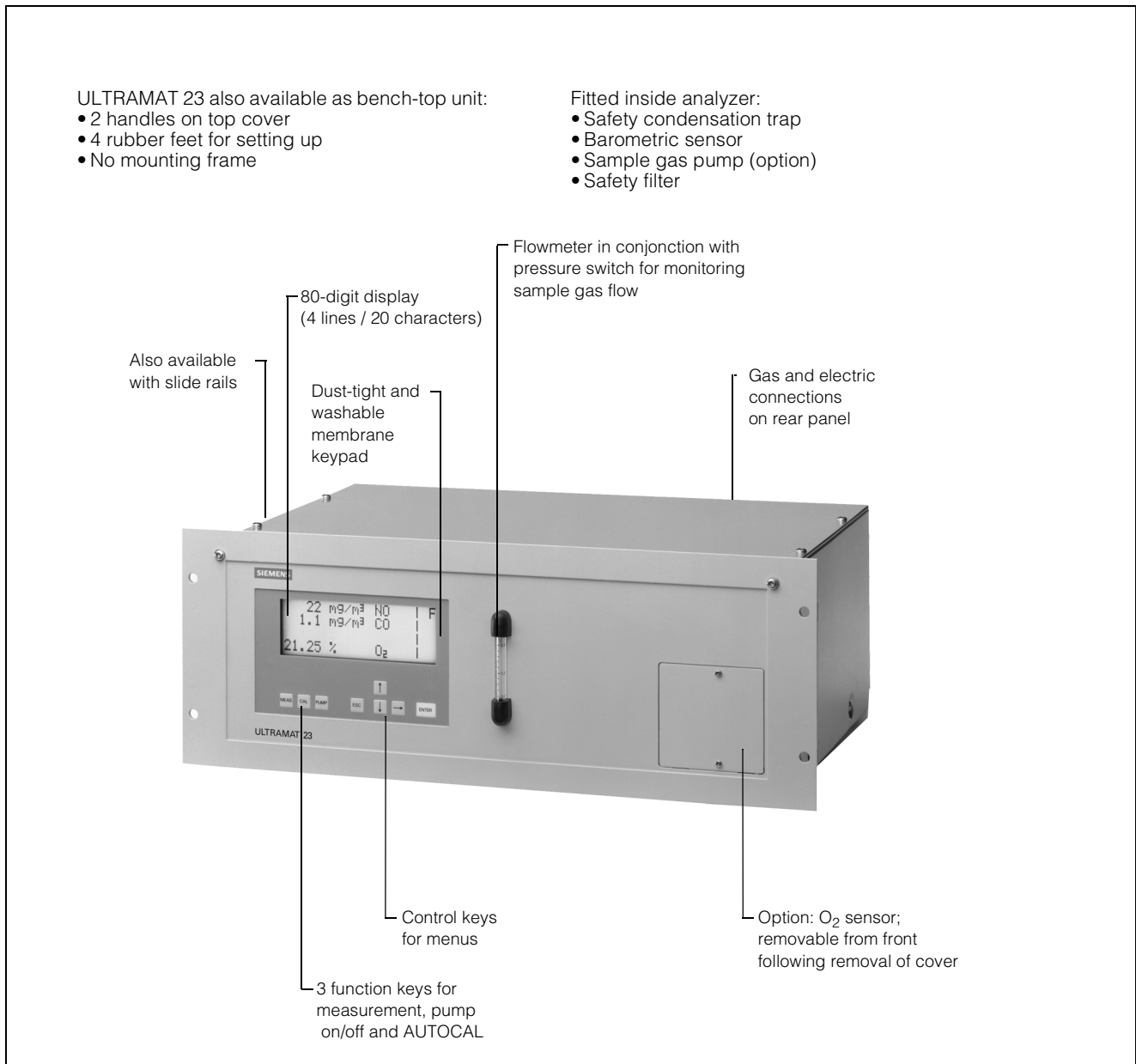

Fig. 3.1 ULTRAMAT 23, design

3.3 Special Characteristics

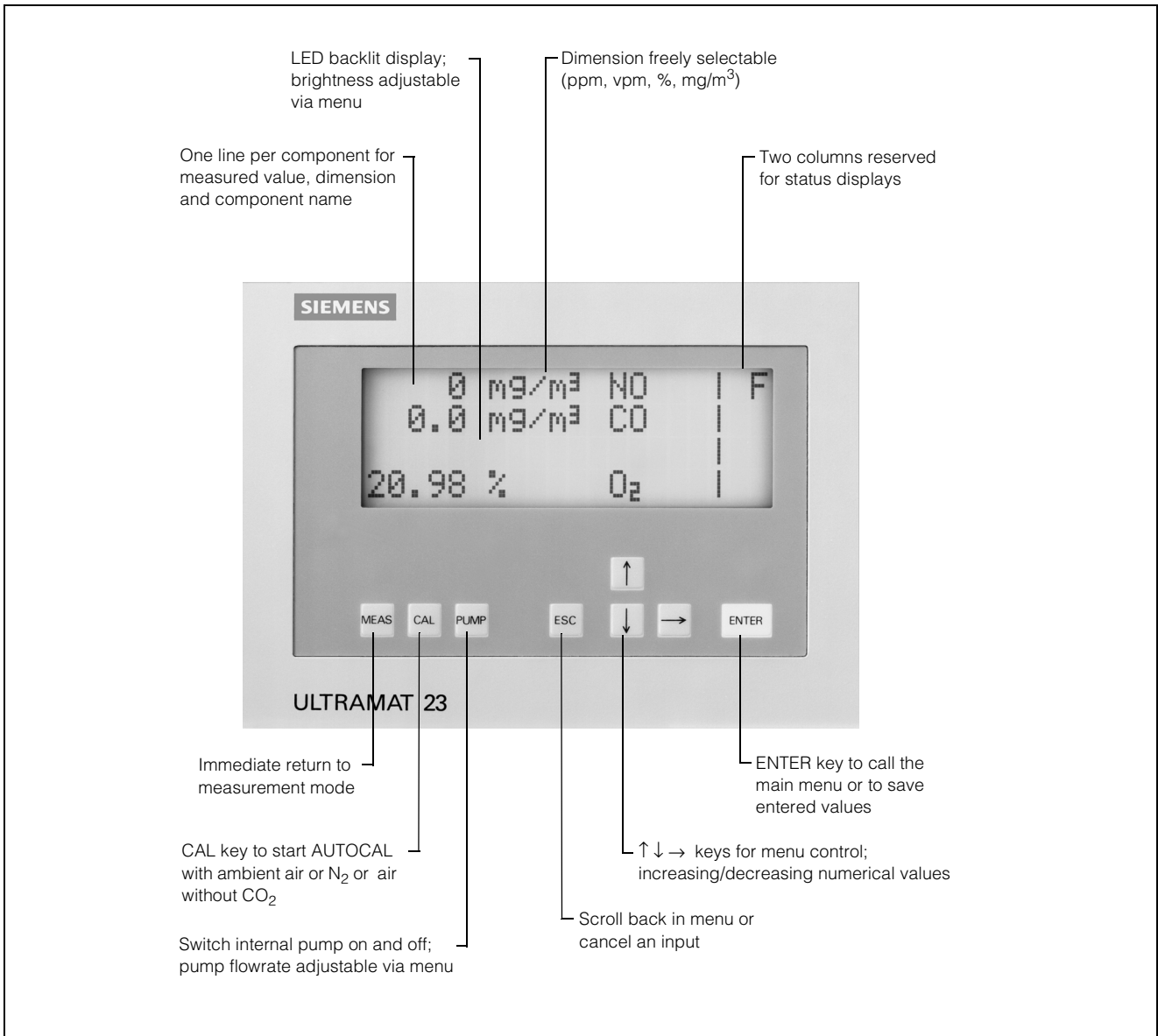

Fig. 3.2 ULTRAMAT 23, membrane keypad and graphical display

3.4 Measuring Principles

Two independent, selective measuring principles are used in the ULTRAMAT 23.

Infrared measurement

This spectroscopic method is based on the absorption of non-dispersive IR radiation. The attenuation in the radiation which depends on the wavelength is a measure of the respective concentration of the gas.

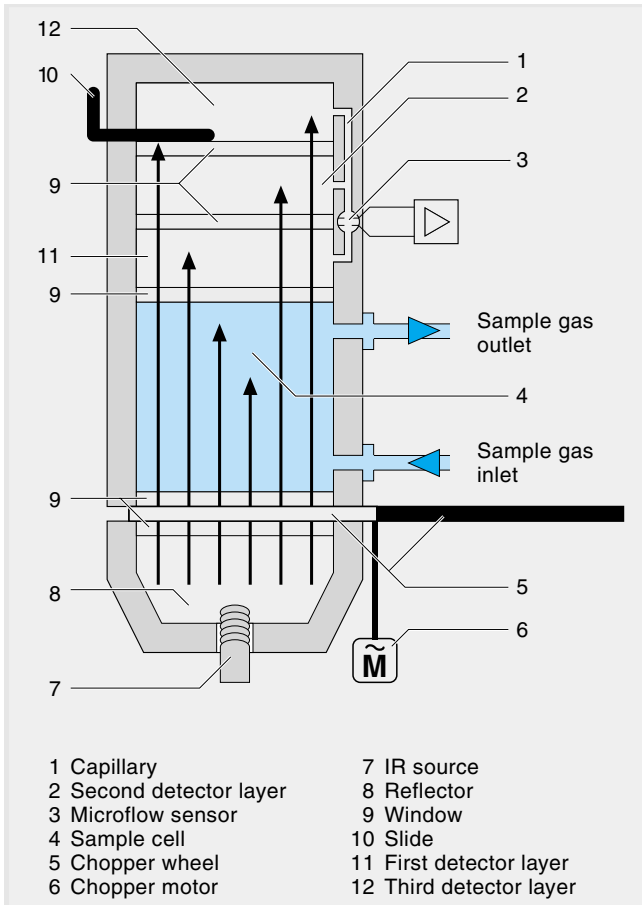

Fig. 3.3 ULTRAMAT 23, mode of operation of infrared channel (example with three-layer detector)

Oxygen measurement

The oxygen sensor operates according to the principle of a fuel cell. The oxygen is converted at the boundary layer between the cathode and electrolyte; the resulting current is proportional to the concentration of oxygen.

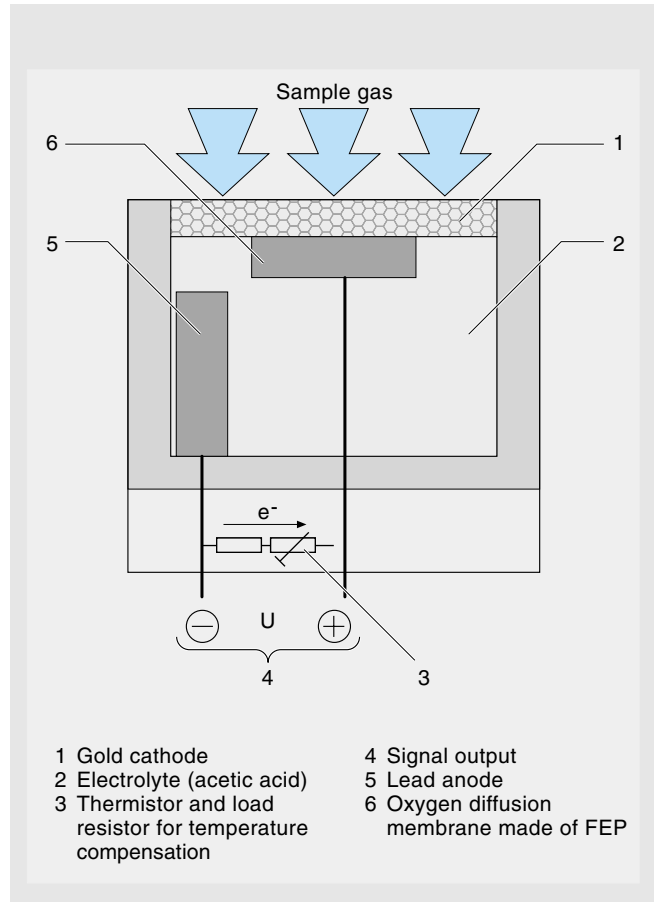

Fig. 3.4 ULTRAMAT 23, mode of operation of oxygen measuring cell

Pin assignments

3.5 Connections

3.5.1 Pin Assignments

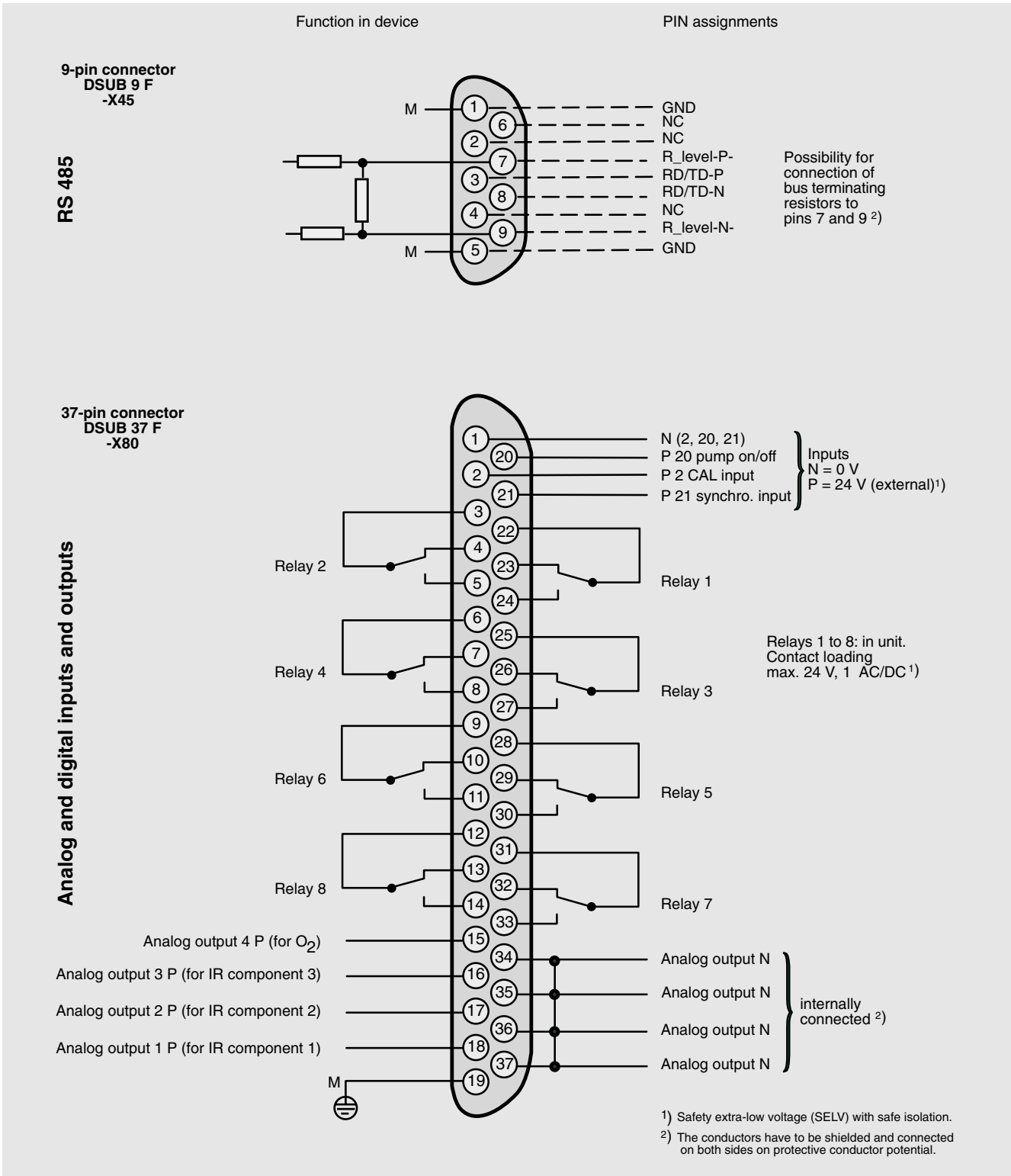

Fig. 3.5 ULTRAMAT 23, pin assignments (standard)

Pin assignments

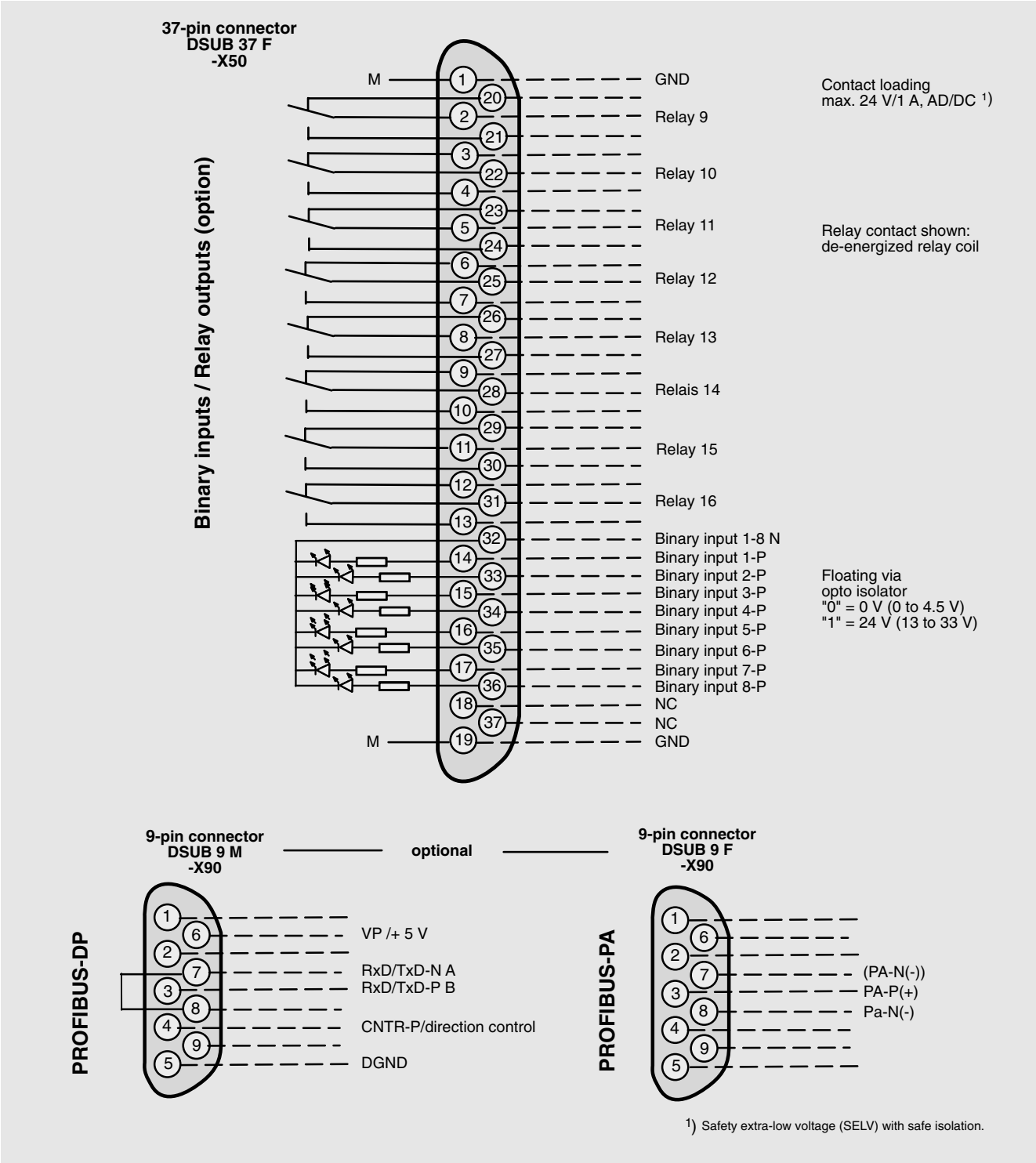

Fig. 3.6 ULTRAMAT 23, pin assignments of the optional interface board PROFIBUS

3.5.2 Internal Gas Paths, Gas Flow Diagrams, Basic Layout

Basic design

- Gas inlets/outlets:
 - Pipe with 6 mm outside diameter or
 - Pipe with 1/4" outside diameter
- Internal gas paths:
 - Viton tube
- Flowmeter
- Pressure switch

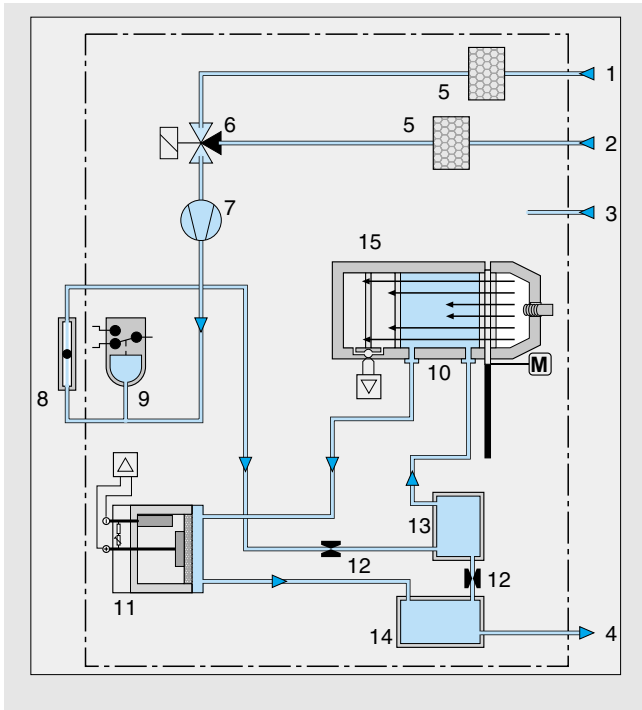

Fig. 3.7 ULTRAMAT 23, 19" unit, e.g. one IR component with oxygen measurement, with internal sample gas pump and safety filter

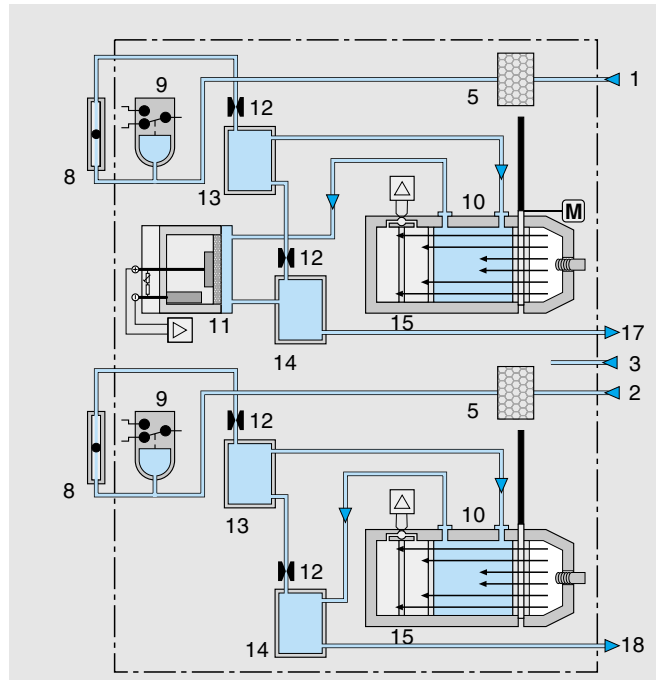

Fig. 3.8 ULTRAMAT 23, 19" unit, two channels with separate gas paths, e.g. two IR components with oxygen measurement, without sample gas pump, with internal safety filter

Key to Figures 7 to 11

- 1 Inlet for sample gas / calibration gas
- 2 Inlet for AUTOCAL / zero gas or inlet for sample gas / calibration gas (channel 2)
- 3 Enclosure purge inlet / chopper purge
- 4 Gas outlet
- 5 Membrane safety filter
- 6 Solenoid valve ¹⁾
- 7 Sample gas pump ¹⁾
- 8 Flowmeter

- 9 Pressure switch
- 10 Sample cell (see Fig. 3.3)
- 11 Oxygen measuring cell¹⁾ (see Fig. 3.4)
- 12 Restrictor
- 13 Condensation trap
- 14 Condensation trap
- 15 Infrared measuring cell
- 16 Condensation trap with filter
- 17 Gas outlet
- 18 Gas outlet (channel 2)

¹⁾ Depending on design, see Ordering data, pages 17 to 22

Internal gas paths, gas flow diagrams (basic layout)

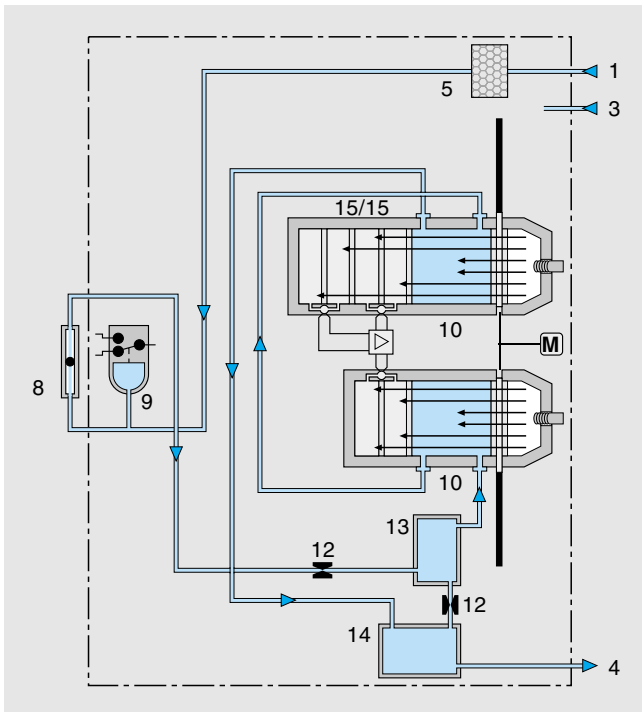

Fig. 3.9 ULTRAMAT 23, 19" unit,
e.g. three IR components without oxygen measurement,
without sample gas pump, with internal safety filter

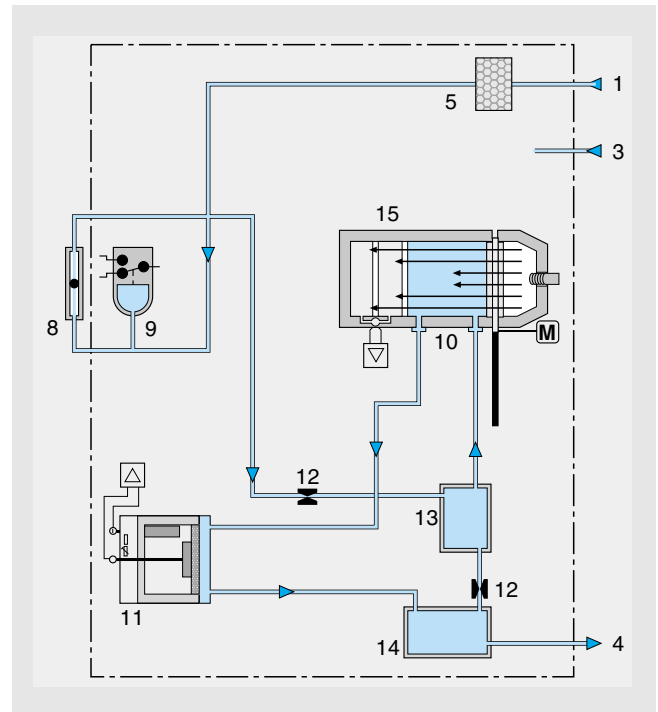

Fig. 3.11 ULTRAMAT 23, 19" unit,
e.g. one IR component with oxygen measurement, without
sample gas pump, with internal safety filter

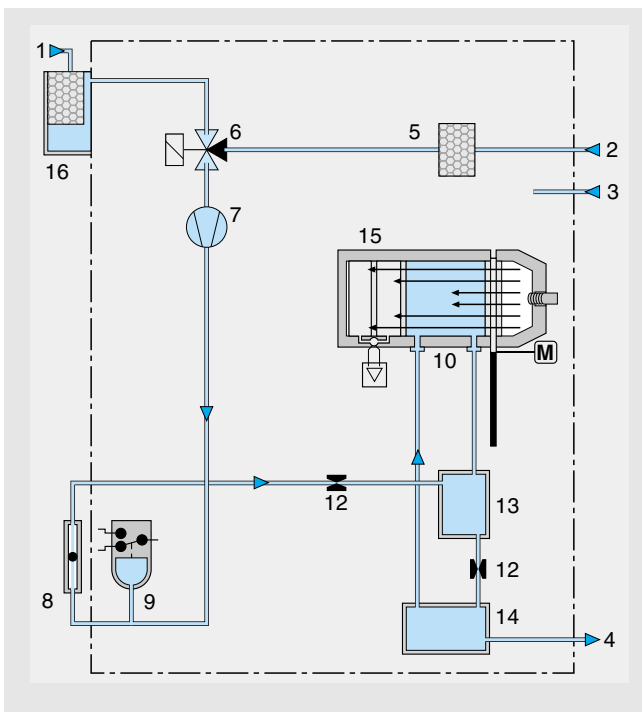

Fig. 3.10 ULTRAMAT 23, portable,
e.g. one IR component without oxygen measurement, with
internal sample gas pump and safety filter, condensation trap
on front panel

3.5.3 Installation and Connection Diagrams

19" rack unit

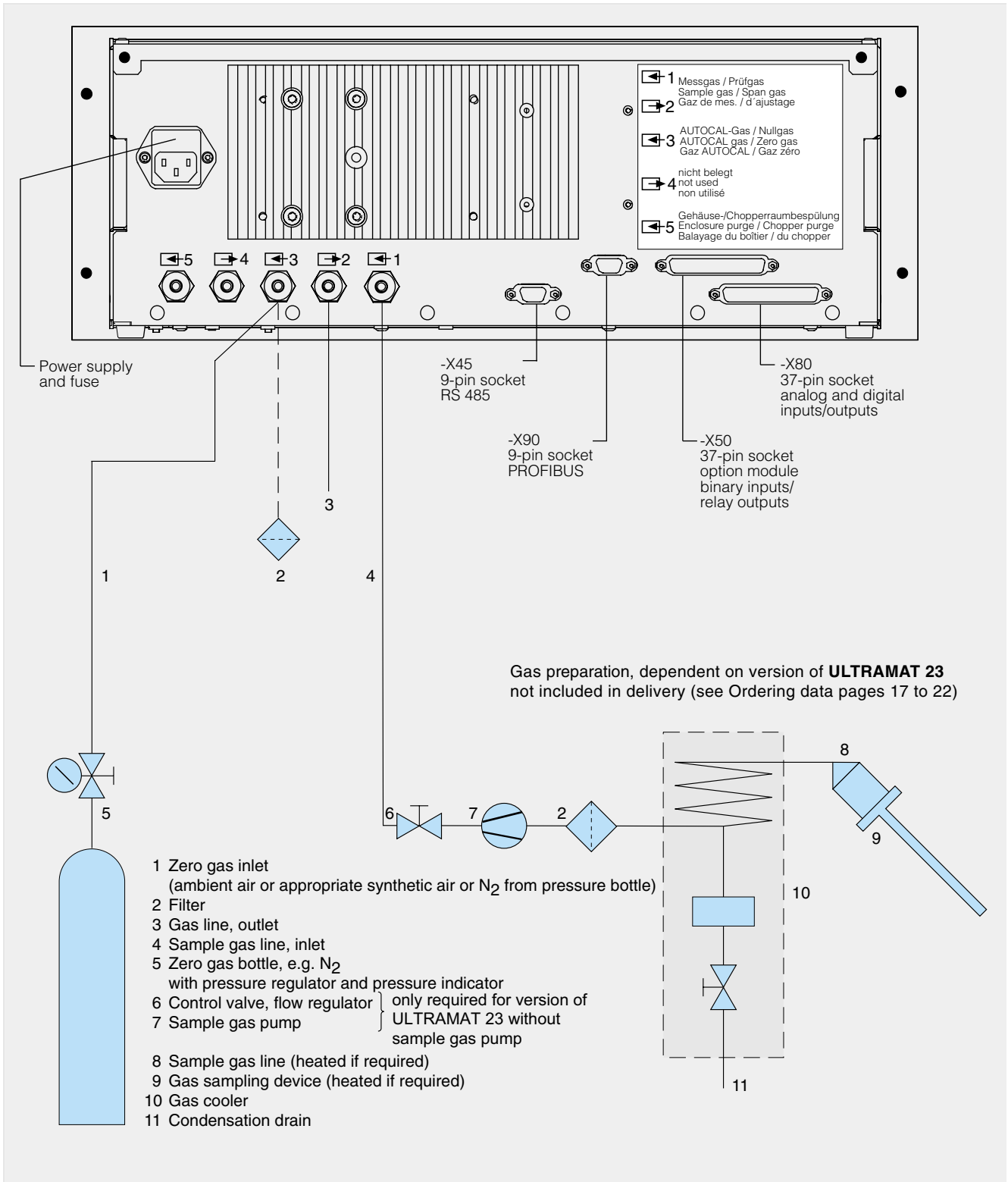
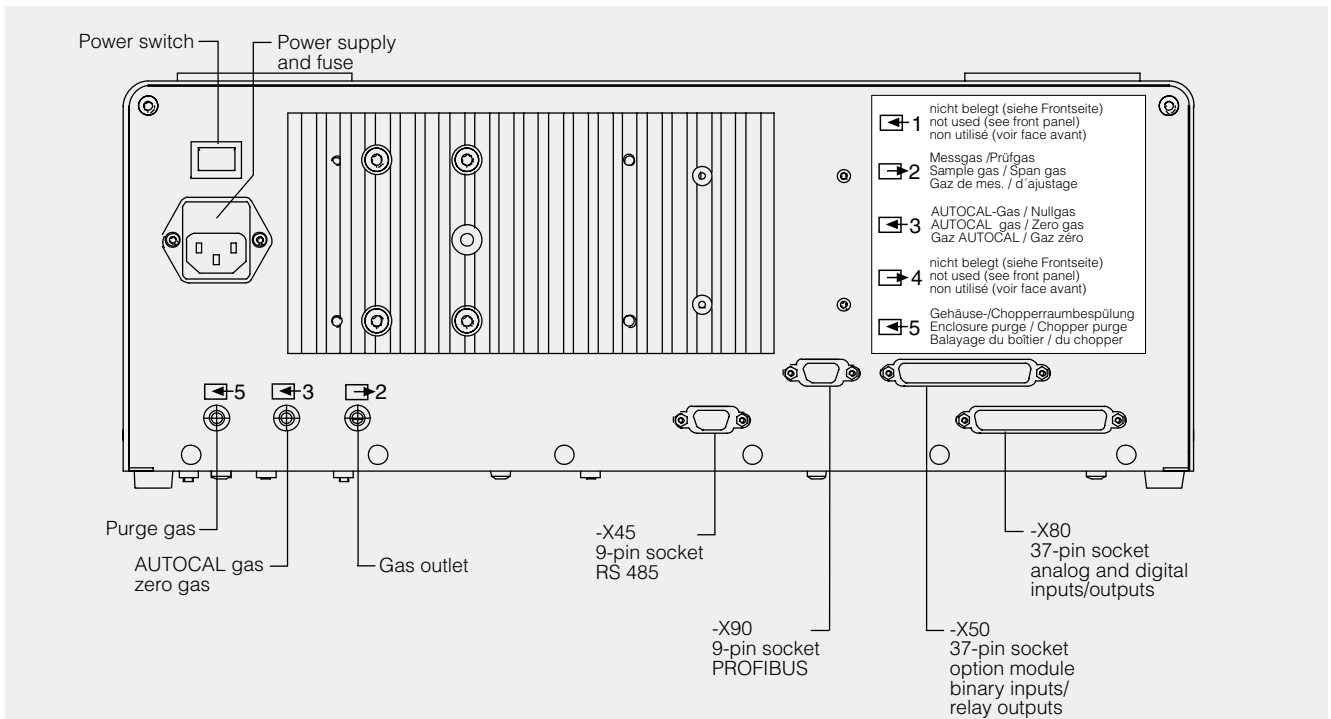

Fig. 3.12 ULTRAMAT 23, 19" unit, e.g. one IR component with oxygen measurement, sample preparation as example

Bench-top unit



The ULTRAMAT 23 bench-top version requires no special assembly.
When installing in a cabinet, mount only on support rails.

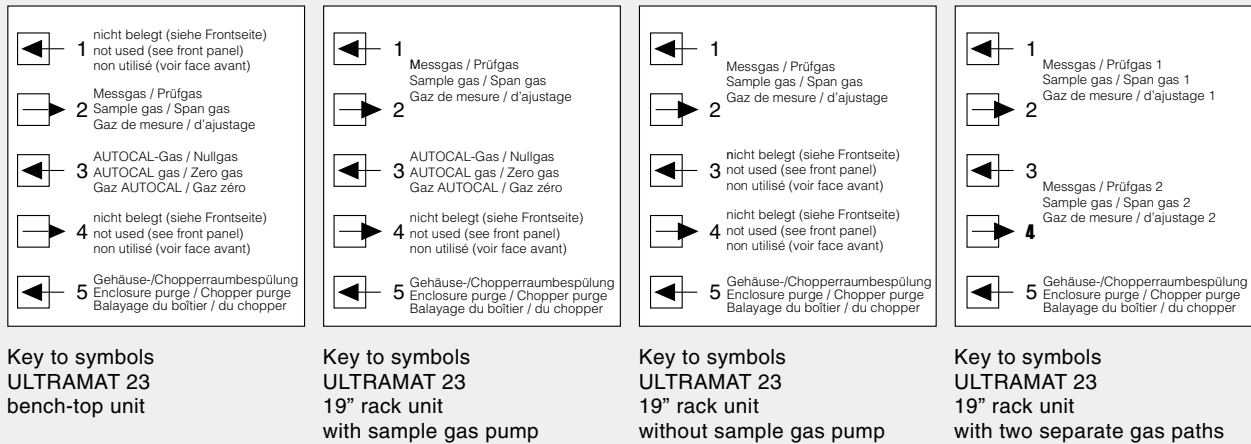

Fig. 3.13 ULTRAMAT 23, bench-top unit, gas and electrical connections (top); the various labels (bottom)

3.5.4 Communication

The gas analyzers of series 6, ULTRAMAT 6 and OXYMAT 6, as well as the ULTRAMAT 23 offer the following communications facilities:

- Serial **RS 485** interface present as standard with internal communications bus (ELAN) which permits communication between the analyzers and – with multi-channel analyzers – from one channel to the other via the serial interface even without a PC for e.g. information on the process gas pressure and compensation of the influences of interfering gases.
- **SIPROM GA**, a software tool especially for servicing and maintenance tasks. All functions of the analyzers, whether an individual device or where several are networked together, can be remote controlled and monitored using SIPROM GA.
- **PROFIBUS-DP/-PA** is the leading fieldbus on the market. All Siemens gas analyzers are suitable for PROFIBUS when equipped with an optional plug-in card (retrofitting also possible) and satisfy the binding "Device profile for analyzers" defined by the **PNO** (PROFIBUS user organization). Central access to the analyzers in the system is possible using the **SIMATIC PDM** operator input software.

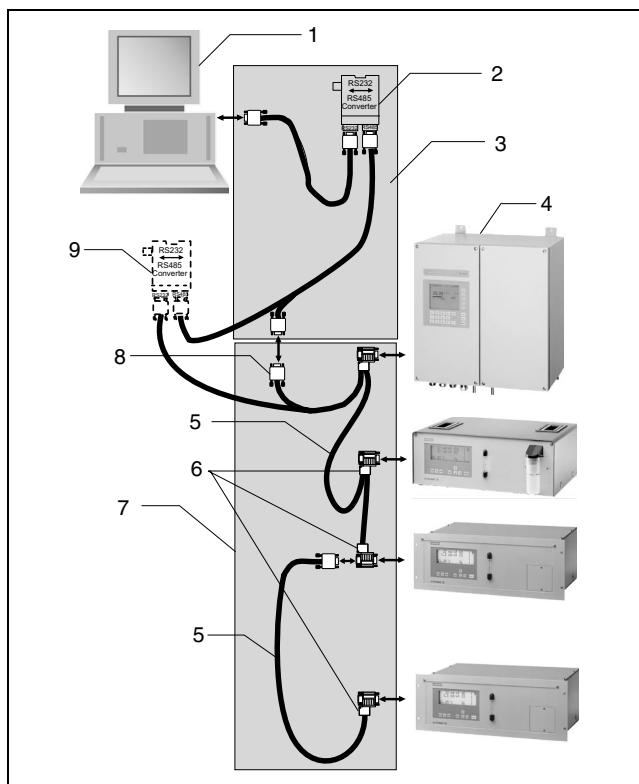

Fig. 14 Typical design of an RS 485 network

Item	Designation
1	Computer
2	RS 485 ↔ RS 232 converter with RS 232/RS 485 cable
3	RS 485 bus connector with jumper
4	Analyzers
5	RS 485 cable
6	RS 485 bus connector
7	RS 485 network
8	9-pin DSUB plug
9	Option: RS 485 repeater

Interface parameters

Level	RS 485
Baud rate	9600
Data bits	8
Stop bit	1
Start bit	1
Parity	None
No echo mode	

Ordering information

Interface description (German)
 RS 485/RS 232 converter
 SIMATIC cable/bus cable
 SIMATIC bus connector
 9-pin DSUB plug
 Repeater
 (see also Catalog CA 01 or IK PI)

Order No.

C79000-B5200-C176
C79451-Z1589-U1
6XV1 830-0EH10
6ES7 972-0BB11-0XA0
6ES7 972-0BB11-0XA0
6ES7 972-0AA01-0XA0

SIPROM GA

Application: communications software for remote maintenance and servicing of Siemens process gas analyzers; max. 12 analyzers with up to 4 components each.

Functions: display and saving of all analyzer data, remote operation of all analyzer functions, parameter and configuration settings; comprehensive diagnostics information, remote calibration; online help; cyclic saving of measured values and status on hard disk and exporting to commercially available application programs, downloading of new software.

Hardware requirements: PC/laptop; min. 486DX-66 with 8 MB RAM, hard disk with min. 10 MB vacant capacity; vacant COM port: RS 232 or RS 485, max. distance 500 m. Larger distances using repeater.

Software requirements: Windows 95/98 or NT (4.0 or later).

Ordering information

SIPROM GA software
 German/English selectable during installation, comprising 3 diskettes (3.5"), with installation instructions, software product certificate and registration form

Order No.

S79610-B4014-A1

Firmware retrofitting sets for older analyzers:

ULTRAMAT 23
 (prior to SW version 2.06)
 All languages

C79451-A3494-S501

ULTRAMAT 6
 (prior to SW version 4.1)

- German
- English
- French
- Spanish
- Italian

C79451-A3478-S501
C79451-A3478-S502
C79451-A3478-S503
C79451-A3478-S504
C79451-A3478-S505

OXYMAT 6
 (prior to SW version 4.1)

- German
- English
- French
- Spanish
- Italian

C79451-A3480-S501
C79451-A3480-S502
C79451-A3480-S503
C79451-A3480-S504
C79451-A3480-S505

ULTRAMAT 23 Gas Analyzer
 C79000-B5276-C216-01

PROFIBUS-DP/PA

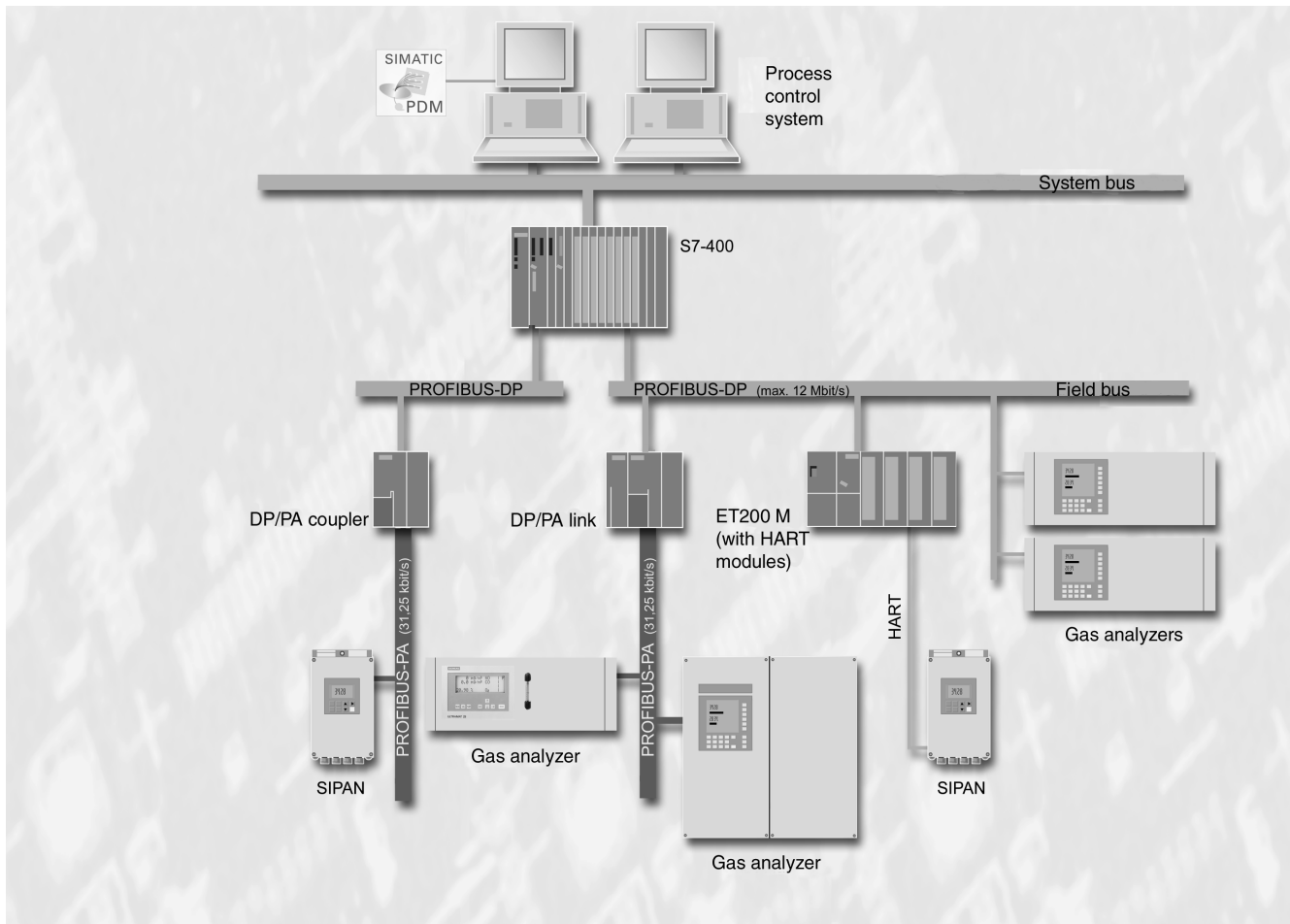

Fig. 3.15 Basic structure of a PROFIBUS system

The term "Field bus" describes a digital communications system with which distributed field devices in a plant are networked together via one single cable, and connected at the same time to programmable controllers or to a process control system. PROFIBUS is the leading field bus on the market. The **PROFIBUS-DP** version is widely used for production automation because of its high transmission rate for relatively small data quantities per device, whereas **PROFIBUS-PA** particularly takes into account the features required for process engineering, e.g. large data quantities and application in potentially explosive atmospheres.

User benefits can be found in the extremely high potentials for cost savings in all areas of the plant, covering configuring and commissioning, operation and maintenance, and up to later plant extensions.

Operation of the gas analyzers from a control system or separate PC is possible using the SIMATIC PDM (Process Device Manager) operator input tool which is software executing under Windows 95/98/NT and which can also be incorporated into the SIMATIC PCS 7 process control system. This permits clear display of both the incorporation of devices into the system and the complex parameter structure of the analyzers, permitting operation to be carried out simply by clicking.

The PROFIBUS user organization (PNO) is an independent international institution, and represents the interests of many vendors and users. In addition to services such as consultation, training ULTRAMAT 23 Gas Analyzer C79000-B5276-C216-01

and device certification, its prime task is the further development, standardization and promotion of the PROFIBUS technology. The definition of a binding functionality for a device class in a profile is a prerequisite for the uniform response of devices for different vendors, the so-called interoperability. The **profile for analyzers** was defined as binding at the end of 1999, thus guaranteeing the interaction of all PROFIBUS-based devices in a plant.

This profile defines the functionality of the analyzers in a block model: e.g. the **physical block** describes the measuring procedure, analyzer and vendor names, serial number and operating state (operation, maintenance). Various **functional blocks** contain the execution of specific functions such as the processing of measured values or alarms. The **transducer blocks** describe the functionality of the actual measuring procedure and its control, e.g. preprocessing of a measured value, correction of cross-interferences, characteristics, measuring ranges as well as switching and control procedures. Protocols define the data transmission between the stations on the bus. A differentiation is made between **cyclic and acyclic services**. Cyclic services are used to transmit time-critical data such as measured values and statuses. The acyclic services permit the scanning or modification of device parameters during operation.

All gas analyzers of Series 6, ULTRAMAT 6 and OXYMAT 6, as well as the ULTRAMAT 23 are suitable for PROFIBUS when fitted with the optional plug-in card (retrofitting also possible, see Ordering information).

3.6 Technical Data

General technical data

Measured components	Max. 4, of which up to 3 infrared-sensitive gases plus oxygen
Analog outputs	Max. 4, floating, 0/2/4 to 20 mA, linearized
Load	≤ 750 Ω
Characteristics	Linearized
Display	LCD with LED backlighting and contrast control, function keys 80 characters (4 lines/20 characters)
EMC interference immunity (ElectroMagnetic Compatibility)	According to standard requirements of NAMUR NE21 (05/93) or EN 50081-1, EN 50082-2
Position of use	Front panel vertical
Relay outputs	8, e.g. for fault, maintenance request, limit, function check, max. load AC/DC 24 V / 1 A ¹⁾ 8 additional outputs as an option
Binary inputs	3, floating for pump on/off, trigger AUTOCAL and synchronization of several devices 8 additional inputs as an option
Serial interface	RS 485
Warming-up time	Approx. 5 min ²⁾
AUTOCAL function	Automatic analyzer calibration, cycle time adjustable from 0(1) to 24 hours
Dimensions (in mm)	See Fig. 16 and Fig. 3.17
Portable analyzer (H x W x D)	170 mm x 465 mm x 392 mm
Frame	19", 4 standard height units = 177 mm x 483 mm
Weight	Approx. 10 kg
Degree of protection to EN 60529	
19" rack and portable unit	IP 21

Power supply

Power supply	AC 100 V, +10%/-15%, 50 Hz AC 120 V, +10%/-15%, 50 Hz AC 200 V, +10%/-15%, 50 Hz AC 230 V, +10%/-15%, 50 Hz AC 100 V, +10%/-15%, 60 Hz AC 120 V, +10%/-15%, 60 Hz AC 230 V, +10%/-15%, 60 Hz
Power consumption	Approx. 60 VA

Gas input conditions

Sample gas pressure	0.5 to 1.5 bar absolute ³⁾
Sample gas flow	66 to 120 l/h (1.2 to 2 l/min)
Sample gas temperature	0 to 50 °C
Sample gas humidity	< 90% RH ⁴⁾ , no condensation

Ambient conditions

Perm. ambient temperature	
Operation	+ 5 to +45 °C
Storage and transport	- 20 to +60 °C
Permissible ambient humidity	< 90% RH ⁴⁾ for storage and transport
Permissible pressure variations	700 to 1200 mbar

¹⁾ Safety extra-low voltage (SELV) with safe isolation
²⁾ Maximum accuracy is achieved after approx. 45 minutes
³⁾ Factory-adjusted with 2 m pipe, span calibration may be required for other conditions
⁴⁾ RH: relative humidity

Technical data of infrared measurement

Measuring ranges	See Ordering data
Smallest measuring range	See Ordering data
Largest measuring range	See Ordering data
Influencing variables	
• Drift with AUTOCAL	Negligible
• Drift without AUTOCAL	< 2% of smallest meas. range/week
• Temperature	Max. 2% of smallest meas. range according to rating plate per 10 K with an AUTOCAL cycle time of 3 h
• Atmospheric pressure	< 0.2% of measured range per 1% change in pressure, corrected by internal pressure sensor
• Power supply	< 0.1% of output signal span with a variation of ±10%
• Power frequency	± 2% of full-scale value with a frequency variation of ± 5%
Electromagnetic field 10 V/m, 80% amplitude modulation, 10 kHz to 500 MHz	≤ 1% of smallest measuring range
500 MHz to 1 GHz	≤ 2% of smallest measuring range
Display delay (90% time)	Dependent on dead time and selectable damping
Damping (electric time constant)	Selectable from 0 to 99.9 s
Noise of output signal	< 1% of smallest measuring range (see rating plate)
Display resolution	Dependent on selected measuring range; the number of digits after the decimal point can be selected
Resolution of output signal	< 0.1% of output signal span
Characteristic	Linearized
Linearity error	In the largest measuring range: < 1% of full-scale value In the smallest measuring range: < 2% of full-scale value
Reproducibility	≤ 1% of smallest measuring range

Technical data of oxygen measurement

Measuring ranges	0 to 5% or 0 to 25% O ₂ , parameter can be set
Influencing variables	
• Drift with AUTOCAL	Negligible
• Drift without AUTOCAL	1% O ₂ /year in air, typical
• Temperature	< 0.5% O ₂ per 20 K, referred to a measured value at 20 °C
• Atmospheric pressure	< 0.2% of measured value per 1% pressure variation
• Auxiliary gas	NH ₃ in % range reduces the lifetime
• Typical combustion exhaust gas	Influence < 0.05% O ₂
Noise of output signal	< 0.5% of full-scale value
Display delay (90% time)	Dependent on dead time and selectable damping, but not < 30 s with a sample gas flow of approx. 1 l/min
Display resolution	< 0.2% of full-scale value
Resolution of output signal	< 0,2% of output signal span
Lifetime	Approx. 2 years with 21% O ₂
Reproducibility	≤ 0.05% O ₂

3.7 Dimensions

19" rack unit

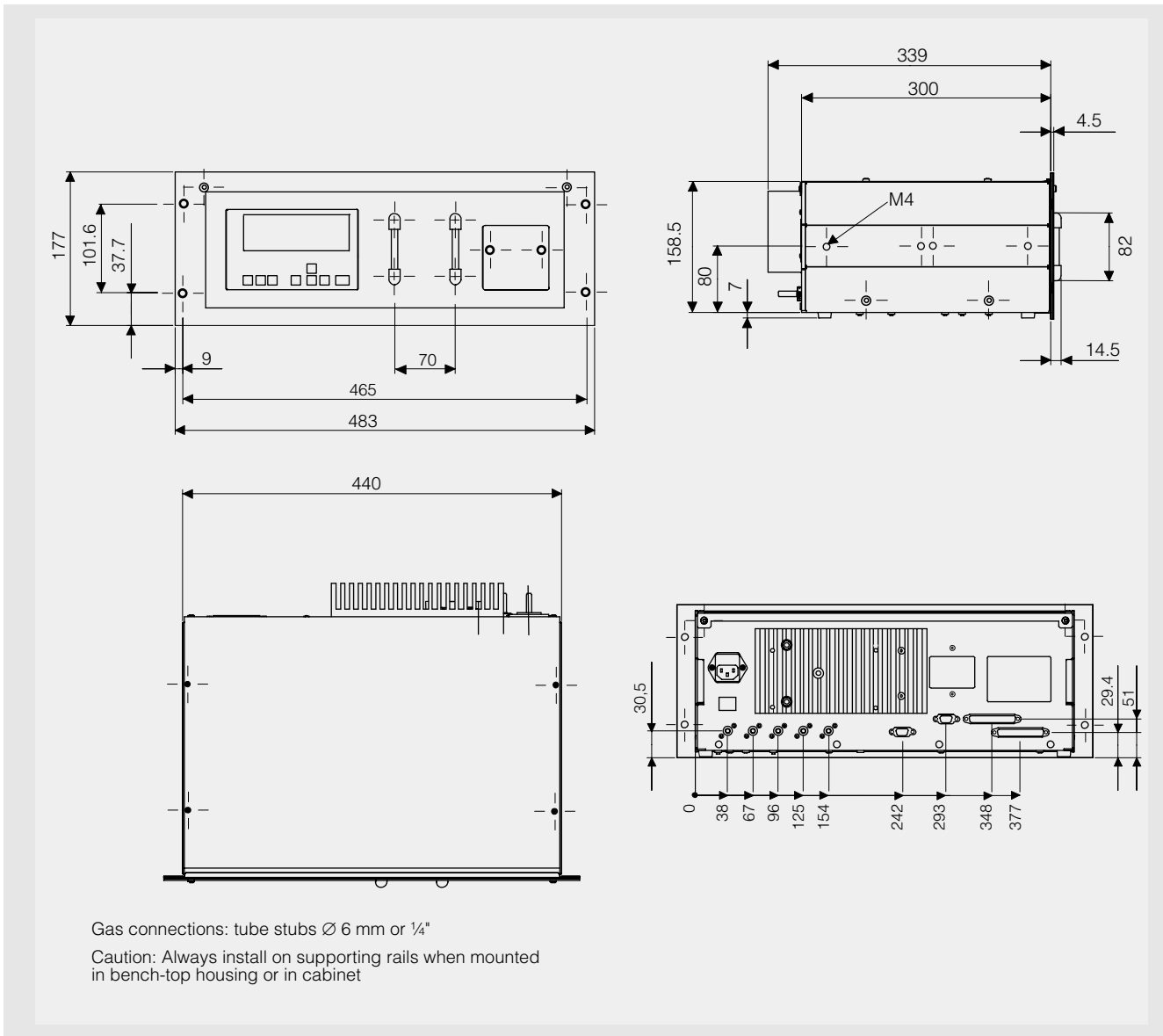

Fig. 16 ULTRAMAT 23, 19" rack, dimensions in mm

Bench-top unit

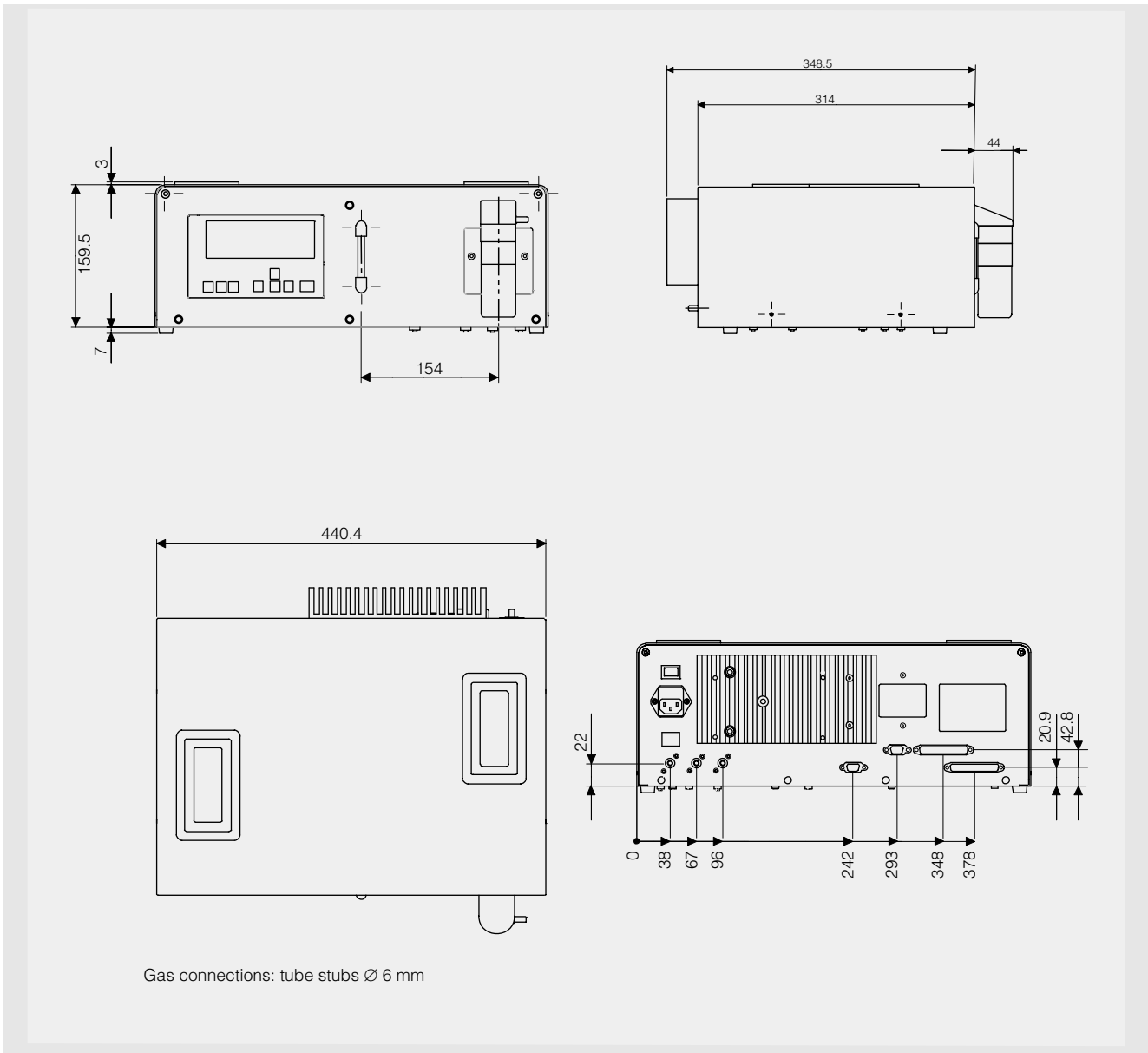

Fig. 3.17 ULTRAMAT 23, bench-top unit, dimensions in mm

3.8 Ordering Data

ULTRAMAT 23 gas analyzer for measurement of 1 infrared component and oxygen

Enclosure, version and gas paths

- 19" unit for cabinet mounting

Gas connections	Internal sample gas pump
6 mm pipe	without ²⁾
¼" pipe	without ²⁾
6 mm pipe	with
¼" pipe	with

- portable, in sheet-steel enclosure, 6 mm gas connections, with internal sample gas pump, condensation trap with safety filter on front panel

Measured component	Possible with range classification codes
CO	D, E, F, G R, U, X
CO ₂ ^{1) 8)}	D, G, J R
CH ₄	H, L, N, P, R
C ₂ H ₄	K
SO ₂	F L, W
NO	G J, V, W
R22	H

Smallest measuring range	Largest measuring range
0 to 20 vpm	0 to 100 vpm
0 to 50 vpm	0 to 250 vpm
0 to 100 vpm	0 to 500 vpm
0 to 150 vpm	0 to 750 vpm
0 to 200 vpm	0 to 1 000 vpm
0 to 500 vpm	0 to 2 500 vpm
0 to 1000 vpm	0 to 5 000 vpm
0 to 2000 vpm	0 to 10 000 vpm
0 to 0.5 %	0 to 2.5 %
0 to 1 %	0 to 5 %
0 to 2 %	0 to 10 %
0 to 5 %	0 to 25 %
0 to 10 %	0 to 50 %
0 to 20 %	0 to 100 %
0 to 150 mg/m ³	0 to 750 mg/m ³
0 to 250 mg/m ³	0 to 1250 mg/m ³
0 to 400 mg/m ³	0 to 2000 mg/m ³
0 to 50 vpm	0 to 2500 vpm

Oxygen measurement

- without O₂ sensor
- with O₂ sensor

Power supply

- AC 100 V, 50 Hz
- AC 120 V, 50 Hz
- AC 200 V, 50 Hz
- AC 230 V, 50 Hz
- AC 100 V, 60 Hz
- AC 120 V, 60 Hz
- AC 230 V, 60 Hz

Operating software, documentation ³⁾

- German
- English
- French
- Spanish
- Italian

Order No.

7MB2335-

- - - - - 0 - - A A

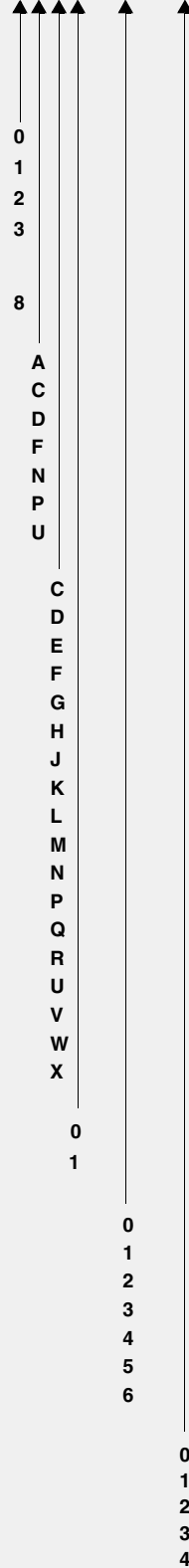

Footnotes see page 3-18

Ordering data

ULTRAMAT 23 gas analyzer for measurement of 1 infrared component and oxygen (continued)

Further versions

Please add „-Z“ to Order No. and specify Order code

	Order code
Interface converter from RS 485 to RS 232 ⁴⁾	A11
Supplementary electronics with 8 binary inputs/relay outputs, PROFIBUS-PA interface	A12
Supplementary electronics with 8 binary inputs/relay outputs, PROFIBUS-DP interface	A13
Slide rails (2 rails) possible only for versions in 19" unit	A31
Set of Torx tools	A32
TAG labels (labeling to customer specification)	B03
Gas path for a short response time	C01
Chopper purge for gas connection 6 mm	C02
Chopper purge for gas connection ¼"	C03
Customer acceptance ⁵⁾	Y01
Measurement range in plain text ⁶⁾	Y11
Accessories	
CO ₂ absorber cartridge	7MB1933-8AA
Interface converter RS 485/RS 232	C79451-Z1589-U1

¹⁾ For measuring ranges below 1% a CO₂ absorber cartridge can be used for the zero setting (see „Ordering data: Accessories“)

²⁾ Without separate zero gas input and without solenoid valve

³⁾ User language switchable

⁴⁾ Supplied separately (including interface description C79000-E5264-C176)

⁵⁾ Customer acceptance: ½ day at factory in presence of customer.
The following work is carried out: comparison of analyzer with ordering data; linearization check (zero, mid point value and full-scale value); reproducibility check with calibration gas (recording in each case on XT recorder, logging of results).

⁶⁾ Standard setting: smallest measuring range, largest measuring range

⁷⁾ O₂ sensor in gas path of infrared measured component 1

⁸⁾ With chopper purge (N₂ approx. 3 bar for measuring ranges below 0.1 % CO₂ required), order in addition (see Order code C02 or C03)

Note:

conversion factors with optional selection of dimensions ppm (vpm) in mg/m³ at norm condition (0 °C; 1013 mbar)
 SO₂: 0.35 ppm ≈ 1 mg/m³
 NO: 0.75 ppm ≈ 1 mg/m³
 CO: 0.80 ppm ≈ 1 mg/m³

Example for ordering

ULTRAMAT 23 gas analyzer
 For measurement of one IR component and oxygen
 IR channel, component: CO₂

Measuring range1: 0 to 1000 vpm and range 2: 0 to 5000 vpm
 Channel 2, component: O₂
 Range: 0 to 5% and 0 to 25%

Power supply: 230 V, 50 Hz,
 19" unit for installation in cabinets,
 Gas connections ¼" pipe with sample gas pump
 Software and documentation in Spanish,
 2 slide rails and customer acceptance

Order No.: **7MB2335-3CJ10-3AA3-Z
 A31+Y01**

Ordering data

ULTRAMAT 23 gas analyzer for measurement of 2 infrared components and oxygen

Enclosure, version and gas paths

- 19" unit for cabinet mounting

Gas connections	Internal sample gas pump	Separate gas paths (2 chan.) ⁷⁾
6 mm pipe	without ²⁾	without
¼" pipe	without ²⁾	without
6 mm pipe	with	without
¼" pipe	with	without
6 mm pipe	without ²⁾	with
¼" pipe	without ²⁾	with

- portable, in sheet-steel enclosure, 6 mm gas connections, with internal sample gas pump, condensation trap with safety filter on front panel

1st infrared component

Measured component	Possible with range classification codes
CO	D, E, F, G R, U, X
CO ₂ ^{1) 8)}	D, G, J R
CH ₄	H, L, N, P, R
C ₂ H ₄	K
SO ₂	F L, W
NO	G J, V, W
R22	H

Smallest measuring range **Largest measuring range**

0 to 20 vpm	0 to 100 vpm
0 to 50 vpm	0 to 250 vpm
0 to 100 vpm	0 to 500 vpm
0 to 150 vpm	0 to 750 vpm
0 to 200 vpm	0 to 1 000 vpm
0 to 500 vpm	0 to 2 500 vpm
0 to 1000 vpm	0 to 5 000 vpm
0 to 2000 vpm	0 to 10 000 vpm
0 to 0.5 %	0 to 2,5 %
0 to 1 %	0 to 5 %
0 to 2 %	0 to 10 %
0 to 5 %	0 to 25 %
0 to 10 %	0 to 50 %
0 to 20 %	0 to 100 %
0 to 150 mg/m ³	0 to 750 mg/m ³
0 to 250 mg/m ³	0 to 1250 mg/m ³
0 to 400 mg/m ³	0 to 2000 mg/m ³
0 to 50 vpm	0 to 2500 vpm

Oxygen measurement

- without O₂ sensor
- with O₂ sensor

Power supply

- AC 100 V, 50 Hz
- AC 120 V, 50 Hz
- AC 200 V, 50 Hz
- AC 230 V, 50 Hz
- AC 100 V, 60 Hz
- AC 120 V, 60 Hz
- AC 230 V, 60 Hz

Order No.

7MB2337-

- - - - - 0 - - - - -

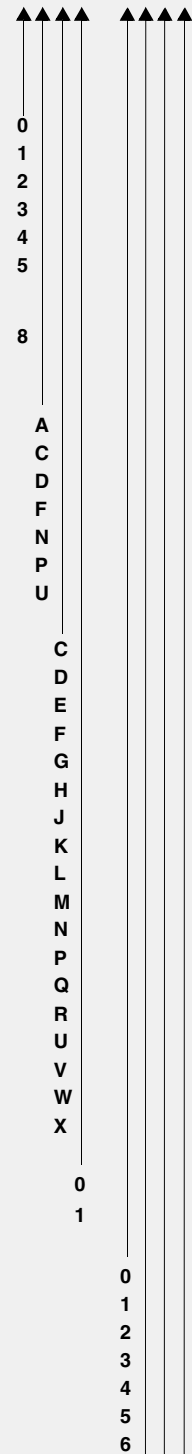

see next page

Footnotes see page 3-18

Ordering data		Order No.
ULTRAMAT 23 gas analyzer for measurement of 2 infrared components and oxygen (continued)		7MB2337- - ■ ■ ■ ■ ■ 0 - ■ ■ ■ ■ ■
2nd infrared component		
<u>Measured component</u>	<u>Possible with range classification figures</u>	
CO	D, E, F, G R, U, X	
CO ₂ ^{1) 8)}	D, G, J R	
CH ₄	H, L, N, P, R	
C ₂ H ₄	K	
SO ₂	F L, W	
NO	G J, V, W	
R22	H	
<u>Smallest measuring range</u>	<u>Largest measuring range</u>	
0 to 20 vpm	0 to 100 vpm	
0 to 50 vpm	0 to 250 vpm	
0 to 100 vpm	0 to 500 vpm	
0 to 150 vpm	0 to 750 vpm	
0 to 200 vpm	0 to 1 000 vpm	
0 to 500 vpm	0 to 2 500 vpm	
0 to 1000 vpm	0 to 5 000 vpm	
0 to 2000 vpm	0 to 10 000 vpm	
0 to 0.5 %	0 to 2.5 %	
0 to 1 %	0 to 5 %	
0 to 2 %	0 to 10 %	
0 to 5 %	0 to 25 %	
0 to 10 %	0 to 50 %	
0 to 20 %	0 to 100 %	
0 to 150 mg/m ³	0 to 750 mg/m ³	
0 to 250 mg/m ³	0 to 1250 mg/m ³	
0 to 400 mg/m ³	0 to 2000 mg/m ³	
0 to 50 vpm	0 to 2500 vpm	
Operating software, documentation ³⁾		
• German		0
• English		1
• French		2
• Spanish		3
• Italian		4

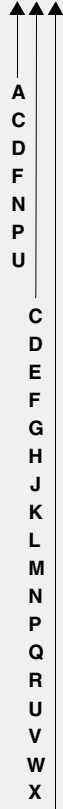

Ordering data	Order code
Further versions Please add „-Z“ to Order No. and specify Order code	
Interface converter from RS 485 to RS 232 ⁴⁾	A11
Supplementary electronics with 8 binary inputs/relay outputs, PROFIBUS-PA interface	A12
Supplementary electronics with 8 binary inputs/relay outputs, PROFIBUS-DP interface	A13
Slide rails (2 rails) possible only for versions in 19" unit	A31
Set of Torx tools	A32
TAG labels (labeling to customer specification)	B03
Gas path for a short response time	C01
Chopper purge for gas connection 6 mm	C02
Chopper purge for gas connection ¼"	C03
Customer acceptance ⁵⁾	Y01
Measurement range in plain text ⁶⁾	Y11
Accessories	
CO ₂ absorber cartridge	7MB1933-8AA
Interface converter RS 485/RS 232	C79451-Z1589-U1

Footnotes see page 3-18

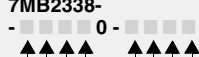
Ordering data			Order No.
ULTRAMAT 23 gas analyzer for measurement of 3 infrared components and oxygen			7MB2338-
Enclosure, version and gas paths			- 
<ul style="list-style-type: none"> 19" unit for cabinet mounting 			
<u>Gas connections</u>	<u>Internal sample gas pump</u>	<u>Separate gas paths (2 chan.) ⁷⁾</u>	
6 mm pipe	without ²⁾	without	0
¼" pipe	without ²⁾	without	1
6 mm pipe	with	without	2
¼" pipe	with	without	3
6 mm pipe	without ²⁾	with	4
¼" pipe	without ²⁾	with	5
<ul style="list-style-type: none"> portable, in sheet-steel enclosure, 6 mm gas connections, with integral sample gas pump, condensation trap with safety filter on front panel 			8
1st and 2nd infrared components			
	<u>Smallest measuring range</u>	<u>Largest measuring range</u>	
CO	0 to 500 vpm	0 to 2 500 vpm	A A
NO	0 to 500 vpm	0 to 2 500 vpm	A B
CO	0 to 2000 vpm	0 to 10 000 vpm	A C
NO	0 to 1000 vpm	0 to 5 000 vpm	A C
CO	0 to 1000 vpm	0 to 5 000 vpm	A C
NO	0 to 1000 vpm	0 to 5 000 vpm	A C
CO	0 to 250 mg/m ³	0 to 1 250 mg/m ³	A K
NO	0 to 400 mg/m ³	0 to 2 000 mg/m ³	A K
CO	0 to 10 %	0 to 50 %	B A
CO ₂	0 to 10 %	0 to 50 %	B A
CO	0 to 10 %	0 to 50 %	B B
CO ₂	0 to 0.5 %	0 to 2.5 %	B B
CO ₂	0 to 5 %	0 to 25 %	C A
CH ₄	0 to 1 %	0 to 5 %	C A
CO ₂	0 to 5 %	0 to 25 %	C B
CH ₄	0 to 2 %	0 to 10 %	C B
Oxygen measurement			
<ul style="list-style-type: none"> without O₂ sensor with O₂ sensor 			0 1
Power supply			
AC 100 V, 50 Hz			0
AC 120 V, 50 Hz			1
AC 200 V, 50 Hz			2
AC 230 V, 50 Hz			3
AC 100 V, 60 Hz			4
AC 120 V, 60 Hz			5
AC 230 V, 60 Hz			6
3rd infrared components			
<u>Measured component</u>	<u>Possible with range classification figures</u>		
CO	D, E, F, G R, U, X		A
CO ₂ ^{1) 8)}	D, G, J R		C
CH ₄	H, L, N, P, R		D
C ₂ H ₄	K		F
SO ₂	F L, W		N
NO	G J, V, W		P
R22	H		U

see next page

Footnotes see page 3-18

Ordering data		Order No.
ULTRAMAT 23 gas analyzer for measurement of 3 infrared components and oxygen (continued)		7MB2338- - ■ ■ ■ ■ ■ 0 - ■ ■ ■ ■ ■
<u>Smallest measuring range</u>	<u>Largest measuring range</u>	
0 to 20 vpm	0 to 100 vpm	
0 to 50 vpm	0 to 250 vpm	
0 to 100 vpm	0 to 500 vpm	
0 to 150 vpm	0 to 750 vpm	
0 to 200 vpm	0 to 1 000 vpm	
0 to 500 vpm	0 to 2 500 vpm	
0 to 1000 vpm	0 to 5 000 vpm	
0 to 2000 vpm	0 to 10 000 vpm	
0 to 0.5 %	0 to 2.5 %	
0 to 1 %	0 to 5 %	
0 to 2 %	0 to 10 %	
0 to 5 %	0 to 25 %	
0 to 10 %	0 to 50 %	
0 to 20 %	0 to 100 %	
0 to 150 mg/m ³	0 to 750 mg/m ³	
0 to 250 mg/m ³	0 to 1250 mg/m ³	
0 to 400 mg/m ³	0 to 2000 mg/m ³	
0 to 50 vpm	0 to 2500 vpm	
Operating software, documentation ³⁾		
<ul style="list-style-type: none"> • German • English • French • Spanish • Italian 		0 1 2 3 4

Ordering data	Order code
Further versions	
Please add „-Z“ to Order No. and specify Order code	
Interface converter from RS 485 to RS 232 ⁴⁾	A11
Supplementary electronics with 8 binary inputs/relay outputs, PROFIBUS-PA interface	A12
Supplementary electronics with 8 binary inputs/relay outputs, PROFIBUS-DP interface	A13
Slide rails (2 rails) possible only for versions in 19" unit	A31
Set of Torx tools	A32
TAG labels (labeling to customer specification)	B03
Gas path for a short response time	C01
Chopper purge for gas connection 6 mm	C02
Chopper purge for gas connection 1/4"	C03
Customer acceptance ⁵⁾	Y01
Measurement range in plain text ⁶⁾	Y11
Accessories	
CO ₂ absorber cartridge	7MB1933-8AA
Interface converter	C79451-Z1589-U1

Footnotes see page 3-18

3.9 Documentation

Catalog extract	Order No.
ULTRAMAT 23 NDIR-Gasanalysengeräte, ein bis drei IR-Kanäle plus Sauerstoff (German)	E86060-K3510-B151-A3
ULTRAMAT 23 Gas Analyzers NDIR gas analyzers, one to three IR channels plus oxygen (English)	E86060-K3510-B151-A3-7600
Analyseurs de gaz ULTRAMAT 23 Analyseurs de gaz NDIR, un à trois canaux infrarouges plus oxygène (French)	E86060-K3510-B151-A3-7700

Manual	Order No.
ULTRAMAT 23 Gasanalysengerät für IR-absorbierende Gase und Sauerstoff (German)	C79000-G5200-C216
ULTRAMAT 23 Gas Analyzers for IR-absorbing Gases and Oxygen (English)	C79000-G5276-C216
ULTRAMAT 23 Analyseurs de gaz pour la mesure de composants infrarouges et d'oxygène (French)	C79000-G5277-C216
ULTRAMAT 23 Analizadores para gases absorbentes de infrarrojo y oxígeno (Spanish)	C79000-G5278-C216
ULTRAMAT 23 Analizzatori ad infrarossi e per ossigeno (Italian)	C79000-G5272-C216

Spare parts list	Order No.
ULTRAMAT 23 Gas Analyzers for IR-absorbing Gases and Oxygen (German, English, French)	C79000-E5264-C217

A spare parts list is part of this document (chapter 7).

3.10 Conditions of Sale and Delivery

Subject to General Conditions of Supply and Delivery for Products and Services of the Electrical and Electronics Industry and to any other conditions agreed upon with the recipients of catalogs.

The technical data, dimensions and weights are subject to change unless otherwise stated on the individual pages of this catalog extract.

The illustrations are for reference only.

The General Conditions for Software Products for Automation shall apply to software products.

Export

The products listed in this catalog may be subject to European, German or U.S. export regulations.

Any export under restriction requires approval by responsible authorities.

Information thereon can be obtained from our acknowledgements, delivery notes and invoices.

A&D/MP/en 7.96

Internet and World Wide Web (WWW)

You can find information on the Automation and Drives Group in the World Wide Web at the address

<http://www.ad.siemens.de>

You can select the home page of the gas analyzers and then access the gas analyzers by selecting „*Products & Solutions*“, „*Process Automation, Test and Measurement Systems*“, „*Products, Systems and Solutions for Process Automation*“, „*Process Analytics*“ and „*Products*“ or by directly entering the Internet address

<http://www.processanalytics.com>



Start-up

4

4.1	Safety Information	4-2
4.2	Preparations for Start-up	4-2
4.3	Start-up	4-3
4.3.1	AUTOCAL	4-3
4.3.2	Calibration	4-4
4.3.3	System Setup with Several Analyzers in Parallel	4-5

4.1 Safety Information



Warning

Certain parts in this analyzer carry dangerous voltages. The housing must be closed before switching on the analyzer.



Warning

The analyzer must not be used in hazardous areas. Explosive gas mixtures (e.g. flammable gases together with air or oxygen in a potentially explosive ratio) must not be measured.

If the sample gas contains flammable components above the lower explosion limit, the required explosion protection measures must be approved of by an authorized inspector.

4.2 Preparations for Start-up

Checking for leaks

The pressure can be measured easiest using a U-tube manometer. Check for leaks in the sample gas paths as follows:

- Apply approx. 0,1 bar to the sample gas path
- Wait for approx. 1 min until the temperature of the inflowing gas has stabilized
- Note the pressure
- Wait another 15 minutes, and note the pressure again.

The sample gas path is sufficiently leak-proof if the pressure has changed by a maximum of 1 hPa (1 mbar) within 15 minutes.

Gas conditioning

Gas sampling devices, gas coolers, condensation traps, filters and any controllers, recorders, or indicators connected should be made ready for operation (refer to respective Instruction Manuals).

Check that the interfaces (see Chapter 3) are correctly assigned and parameterized.

4.3 Start-up

Switching on the power supply

Once you have established that the analyzer is set to the required voltage and that all connections have been made, connect it to the power supply. Switch the analyzer on and permit it to warm up (see Section 5.3).

4.3.1 AUTOCAL

General

The analyzer carries a calibration with the connected medium when switched on. This AUTOCAL calibrates the zero and sensitivity of the IR channels. If an O₂ sensor is present, its sensitivity is calibrated in addition.



Notice

In analyzers without an O₂ sensor, the AUTOCAL can be executed with nitrogen, in the case of analyzers with an O₂ sensor, it must be executed with air. The supplied medium is selected depending on the analyzer configuration (gas connections) and cannot be parameterized using the software.

The chopper section purging must be connected in analyzers with certain CO₂ ranges. This can be achieved using nitrogen or synthetic air with an input pressure of 3 to 3.5 bar, and should be connected at least 30 minutes prior to switching on in order to guarantee good purging of the analyzer section.

You can manually trigger an AUTOCAL during operation by pressing the **CAL** key. The ULTRAMAT 23 can also execute an AUTOCAL cyclically, i.e. at adjustable, regular intervals (see below).

Duration

The duration of the AUTOCAL depends on various factors. It takes approx. 3 min and is comprised as follows:

- Twice the set purge time (see Section 5.8.4)
- Duration of internal electronic adjustment (corresponds to two-and-a-half times the time constant "T90 within"; see Section 5.9.3); if an O₂ sensor is used, the electronic adjustment is at least 60 s.

Cycle time The cycle time of the AUTOCAL (time between two automatically triggered calibrations) can be set between 0 and 24 h. The cyclic calibration is switched off if you enter "0" as the parameter.



Notice

During warm-up mode, however, an AUTOCAL is carried out twice, approx. 5 min and approx. 30 min after switching on.

In order to compensate variations in ambient temperature, you should select cycle times between 3 and 12 h.

4.3.2 Calibration

Use of calibration gas Following installation of the analyzer, you can calibrate it using calibration gas (see Section 5.8). The calibration should be carried out with a gas containing a sufficient concentration of the measured component (between 70 and 100 % of the full-scale value in N₂ or synthetic air).

Caution

The calibration gas is connected via the sample gas inlet.

Carrying out a calibration

- Make sure that the gas flow is between 1.2 and 2.0 l/min.
- The analyzer must have been in operation for at least 30 minutes before commencing with measurements since a good stability of the analyzer section is only guaranteed after this time (99 % value).

Compensation of temperature influence The compensation of the temperature influence is stored in the EEPROM in the ULTRAMAT 23. Modifications can only be made in the factory.

Noise suppression Any noise which may occur can be suppressed by adjusting various time constants (see Section 5.9).

The calibration should be repeated every six to twelve months depending on the ambient conditions.

4.3.3 System Setup with Several Analyzers in Parallel

Example 1

Both analyzers with internal pump and solenoid valve switching between sample gas and zero gas for AUTOCAL

The cyclic AUTOCAL of the master device triggers an AUTOCAL in parallel for the slave device via its digital output SYNC and the digital input SYNC of the slave device.

The simultaneous connection between the digital output SYNC of the slave device and the digital input SYNC of the master device guarantees that zero gas is always passed **simultaneously** through both analyzers.

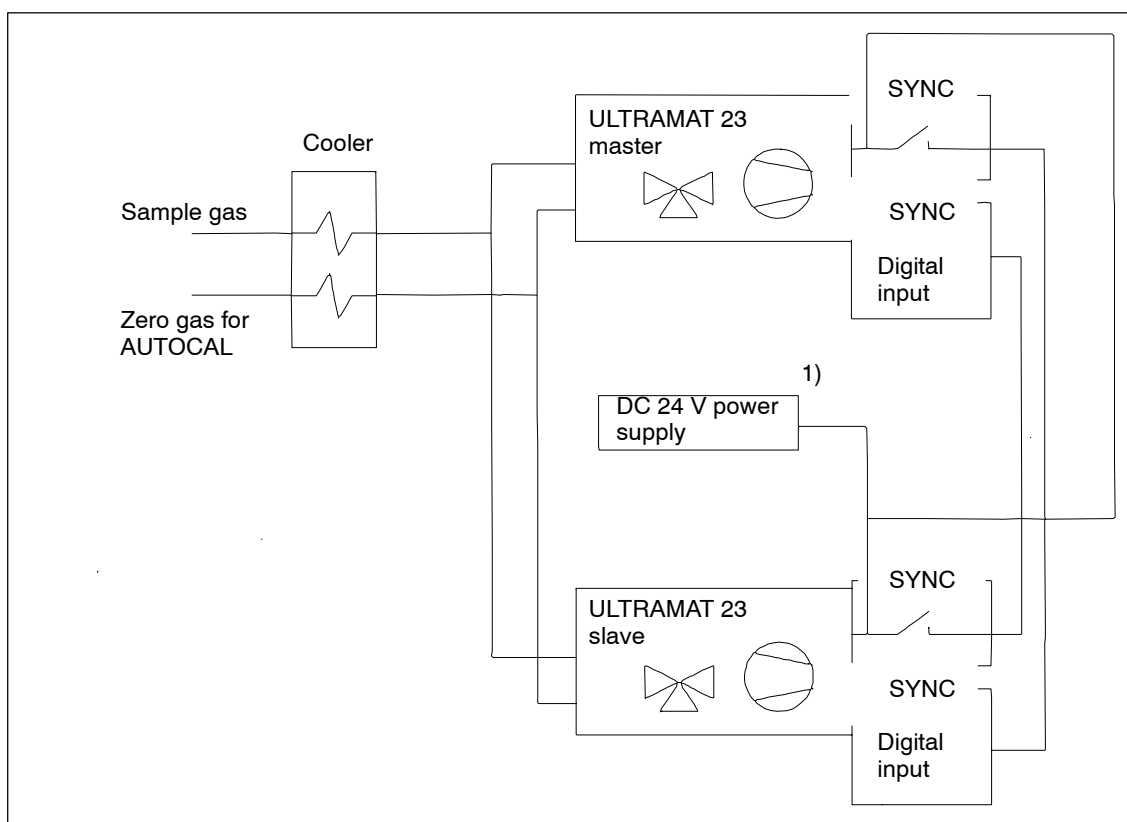

Fig. 4-1 Example with internal pump and solenoid valve switching
 1) Protective extra-low voltage with safe electrical isolation (SELV)

Parameter settings

Master:

- Enter the AUTOCAL cycle time, e.g.: 6 hours (see Section 5.8.4).
- Assign the function "Sync." to a relay (see Section 5.10.1.2).
- Assign the function "CAL/MEAS" to the digital input SYNC (see Section 5.10.1.3).

Slave:

- Set the AUTOCAL cycle time to "0" to prevent a cyclic AUTOCAL from being triggered (see Section 5.8.4).
- Assign the function "Sync." to a relay (see Section 5.10.1.2).
- Assign the function "activate CAL relay" to the digital input SYNC (see Section 5.10.1.3).

Example 2

Both analyzers without internal pump and without internal solenoid valve switching between sample gas and zero gas for AUTOCAL

Via a digital output, the master controls a solenoid valve for switching between sample gas and zero gas for the AUTOCAL.

The cyclic AUTOCAL of the master device triggers an AUTOCAL in parallel for the slave device via its digital output SYNC and the digital input SYNC of the slave device.

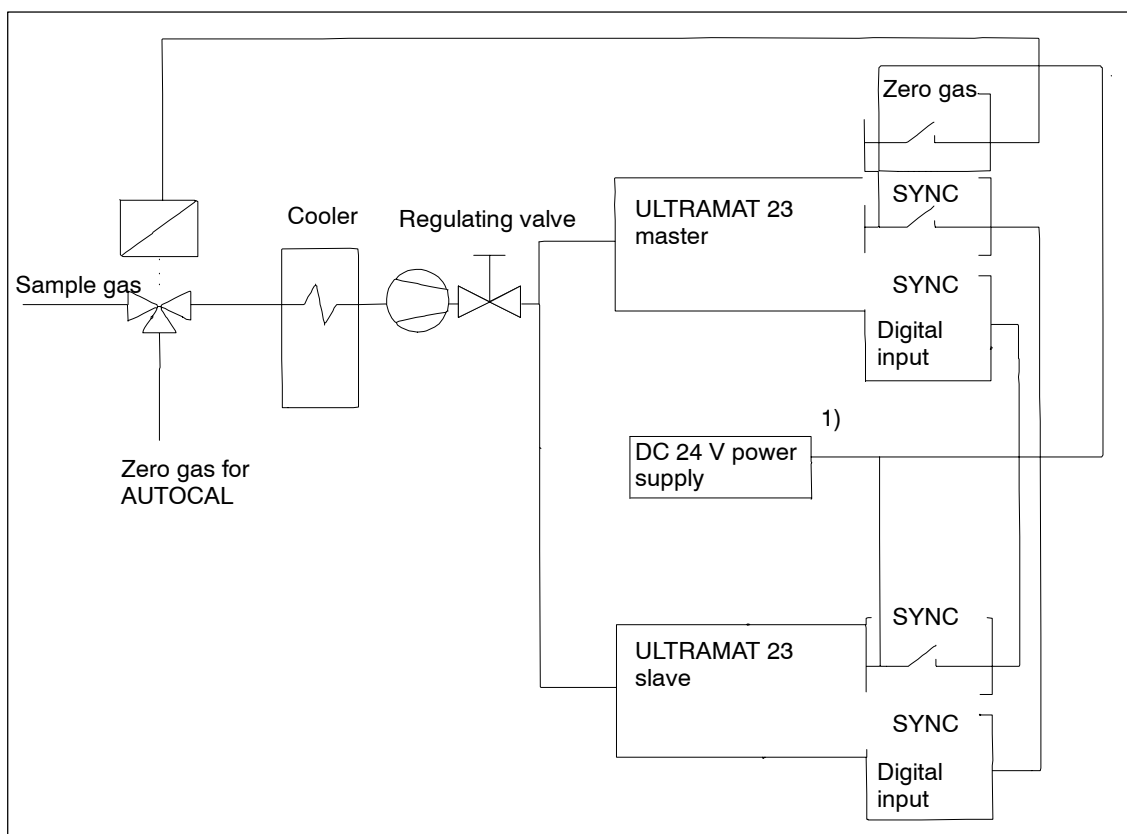

Fig. 4-2 Example without internal pump and solenoid valve switching
 1) Protective extra-low voltage with safe electrical isolation (SELV)

Parameter settings Master:

- Enter the AUTO CAL cycle time, e.g.: 6 hours (see Section 5.8.4).
- Assign the function "Sync." to a relay (see Section 5.10.1.2).
- Assign the function "Zero gas" to a relay (see Section 5.10.1.2).
- Assign the function "activate CAL relay" to the digital input SYNC (see Section 5.10.1.3).

Slave:

- Set the AUTO CAL cycle time to "0" to prevent a cyclic AUTO CAL from being triggered (see Section 5.8.4).
- Assign the function "Sync." to a relay (see Section 5.10.1.2).
- Assign the function "AUTO CAL" to the digital input SYNC (see Section 5.10.1.3).

Operation

5

5.1	General	5-3
5.2	Display and Input Panel	5-4
5.3	Warm-up Mode	5-7
5.4	Measuring Mode	5-8
5.5	Input Mode	5-8
5.5.1	Code Levels	5-9
5.5.2	Key Operations Step-by-step	5-10
5.5.3	Using the ESC key	5-12
5.6	Recoding the Analyzer	5-13
5.7	Analyzer Status	5-15
5.7.1	Analyzer Status: Status	5-15
5.7.1.1	Analyzer Status: Status: Logbook/Faults	5-15
5.7.1.2	Analyzer Status: Status: Maintenance Request	5-16
5.7.1.3	Analyzer Status: Status: AUTOCAL Deviation	5-16
5.7.1.4	Analyzer Status: Status: O2 Sensor Status	5-16
5.7.2	Analyzer Status: Diagnostic Values	5-17
5.7.2.1	Analyzer Status: Diagnostic Values: IR Diagnostic Values	5-17
5.7.2.2	Analyzer Status: Diagnostic Values: O2 Diagnostic Values	5-17
5.7.2.3	Analyzer Status: Diagnostic Values: Pressure Sensor Diagnosis ...	5-18
5.7.2.4	Analyzer Status: Diagnostic Values: Other Diagnostic Values	5-18
5.7.3	Analyzer Status: Factory Settings Hardware	5-19
5.7.4	Analyzer Status: Factory Settings Software	5-19
5.8	Calibration	5-21
5.8.1	Calibration: Calibrate IR Channels	5-21
5.8.1.1	Calibration: Calibrate IR Channels: Set Span Gas Values	5-21
5.8.1.2	Calibration: Calibrate IR Channels: Start with Range MR 1/2	5-22

5.8.2	Calibration: Calibrate O2 Sensor	5-22
5.8.2.1	Calibration: Calibrate O2 Sensor: O2 Cal. after Install	5-22
5.8.2.2	Calibration: Calibrate O2 Sensor: O2 Zero Cal.	5-23
5.8.3	Calibration: Calibrate Pressure Sensor	5-23
5.8.4	Calibration: AUTOCAL	5-24
5.9	Parameters	5-26
5.9.1	Parameters: Measuring Ranges	5-26
5.9.1.1	Parameters: Measuring Ranges: Switch Ranges	5-26
5.9.1.2	Parameters: Measuring Ranges: Change Ranges	5-26
5.9.1.3	Parameters: Measuring Ranges: Hysteresis	5-27
5.9.2	Parameters: Limit values	5-27
5.9.3	Parameters: Time Constants	5-28
5.9.4	Parameters: Pump/LCD Contrast	5-29
5.9.4.1	Parameters: Pump/LCD Contrast: Adjust Pump	5-29
5.9.4.2	Parameters: Pump/LCD Contrast: Adjust LCD Contrast	5-30
5.10	Configuration	5-33
5.10.1	Configuration: Inputs/Outputs/Pump	5-33
5.10.1.1	Configuration: Inputs/Outputs/Pump: Analog Outputs	5-33
5.10.1.2	Configuration: Inputs/Outputs/Pump: Assign Relays	5-34
5.10.1.3	Configuration: Inputs/Outputs/Pump: Binary/Sync Inputs	5-37
5.10.1.4	Configuration: Inputs/Outputs/Pump: Pump at CAL/MEAS	5-38
5.10.2	Configuration: Special Functions	5-38
5.10.2.1	Configuration: Special Functions: Codes/Language	5-38
5.10.2.2	Configuration: Special Functions: AUTOCAL Drift	5-39
5.10.2.3	Configuration: Special Functions: ELAN/PROFIBUS	5-40
5.10.2.4	Configuration: Special Functions: Factory Data/Reset/Units	5-42
5.10.3	Configuration: Tests	5-43
5.10.3.1	Configuration: Tests: Display/Keys/Flow	5-43
5.10.3.2	Configuration: Tests: Inputs/Outputs	5-43
5.10.3.3	Configuration: Tests: Chopper/IR Source	5-45
5.10.3.4	Configuration: Tests: RAM Monitor	5-45
5.10.4	Configuration: Factory Configuration	5-45
5.11	Other Inputs	5-46
5.11.1	PUMP Key	5-46
5.11.2	CAL Key	5-46

5.1 General

The ULTRAMAT 23 has been parameterized and calibrated prior to delivery. However, a large number of parameters can be subsequently adapted to specific requirements using menu-based functions.

The following sections provide you with information on the display and input panel as well as the operating modes. You will learn how to scan analyzer statuses, how to calibrate the analyzer, and how you can enter or modify parameters.

The input sequences are described using the maximum configuration. If your analyzer has a different configuration (different measured components, number of infrared ranges, no oxygen measuring cell, no pump, no serial interface etc.), the explanations can be applied accordingly.

The used numbers must be considered as examples. They therefore probably differ from the values displayed on your analyzer. The corresponding line remains empty if components are not present in your analyzer.

User prompting

In the next sections, operation of the ULTRAMAT 23 is explained according to the following scheme:

Example menu 1: Example menu 2: Example menu 3

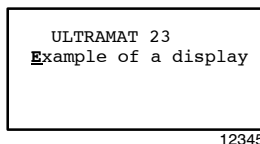

Example text.

Cross-reference.

The heading of the respective section indicates the complete menu path, starting from the main menu, on which the shown display can be reached (see Section 5.2). The various menu levels are separated from one another by colons.

The display, as it appears on the analyzer, is shown to the left of the text. The accompanying text explains the display, including inputs and instructions if necessary, e.g.:

- You can **start** the function using the **ENTER** key
- You can **terminate** the function using the **ESC** key

You can recognize the position of the cursor in the display in these instructions in that the corresponding character is printed in bold type and underlined (in this display: **Eexample**).

The number on the right below the display (12345 in this case) is used as a cross-reference to the summaries of all menus and dialogs which proceed Sections 5.7 to 5.10 in order to facilitate the locating of the described display in these overviews.

A reference may be made that the respective function is protected by a **code level** (see Section 5.5.1) or is **specific to a component**. In the case of functions specific to a component, you must enter the measured components (up to four) for which you wish to call the respective function (see Section 5.5.2).

5.2 Display and Input Panel

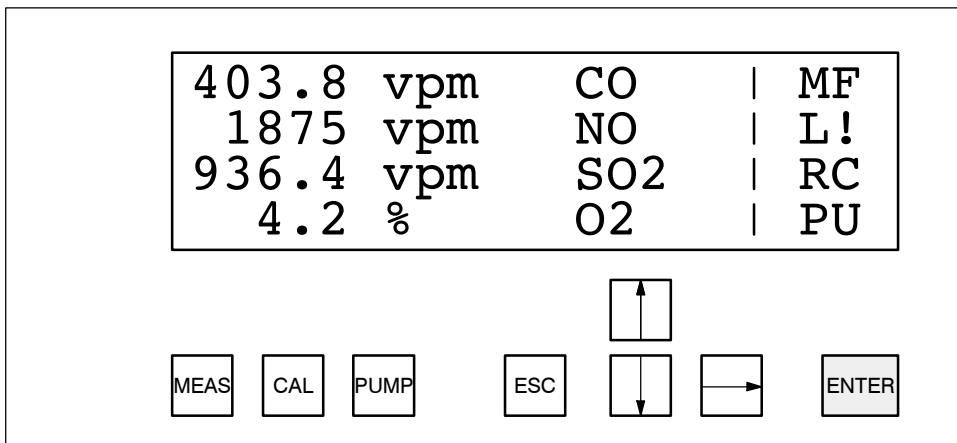

Fig. 5-12 Input panel consisting of display and keypad

The display is a backlit liquid crystal display with four lines with 20 characters each (5 x 8-dot matrix) and is covered by a foil. One line is reserved for each measured component in the display. The line displays from left to right: measured value, dimension and name of component. The last two positions of each line are reserved for displaying certain analyzer statuses. The meanings are as follows:

- M: Maintenance request
- F: Fault present
- L: Limit violated
- !: Fault logged which is no longer present
- R: Remote control
- C: Function Control (analyzer uncoded, or access via RS485 serial interface, or AUTOCAL, or in approx. 30-min warm-up mode)
- P: Pump running
- U: Uncoded

User desktop

The ULTRAMAT 23 has a menu-based user desktop. The menu structures can always be represented as follows: MAIN MENU → Submenu 1 → Submenu 2 → Submenu 3 → Submenu 4.

Fig. Fig. 5-2 shows a diagram of the basic configuration of the user desktop.

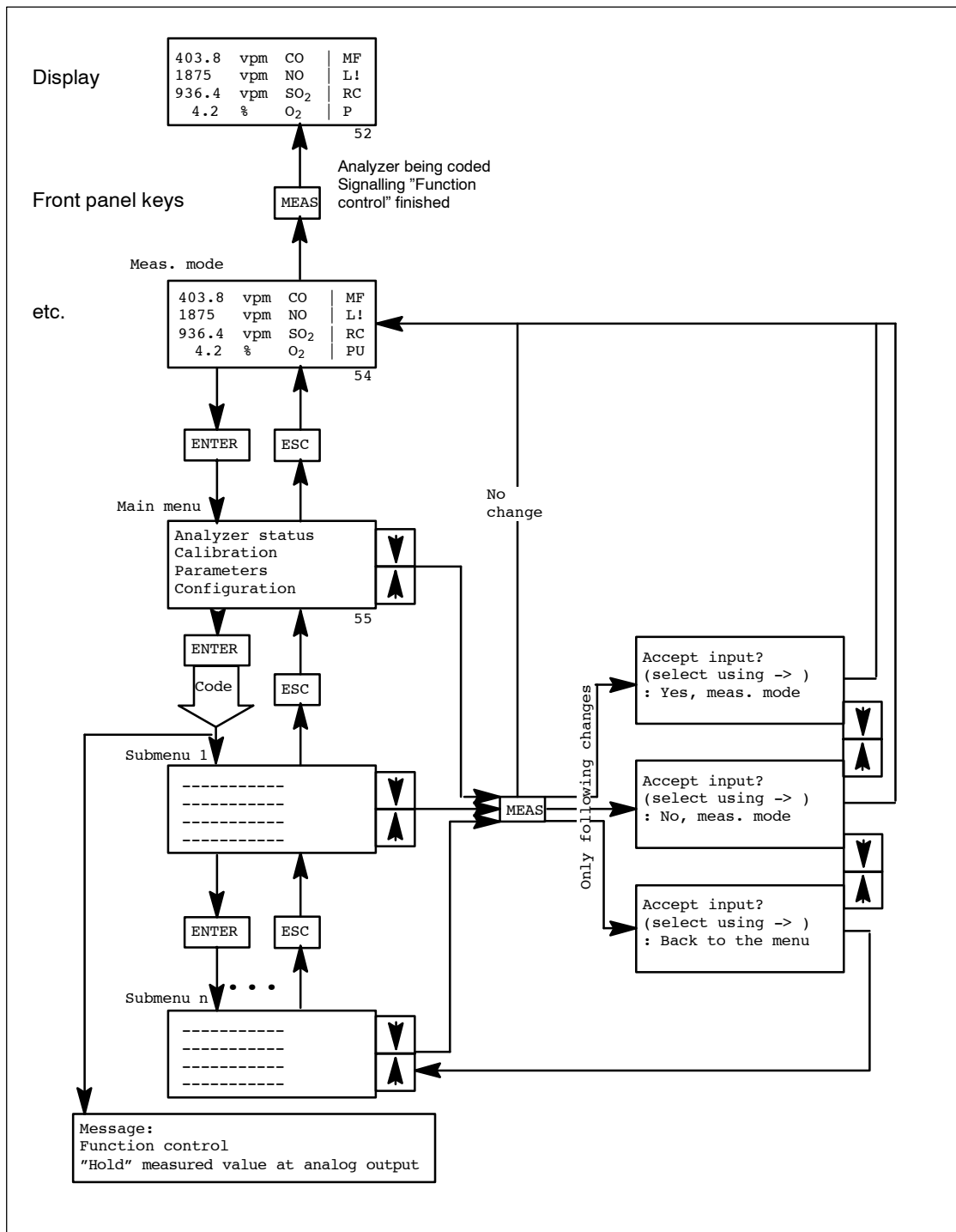

Fig. 5-22 Menu structure of ULTRAMAT 23

Key assignments Eight keys are available for operating the ULTRAMAT 23. These keys have the following meanings:

Table 5-1 Input keys

No.	Designation	Meaning	Function
1*	MEAS	Measure	Measure; abort input operations; leave input mode (from any menu level); switch from input mode to measuring mode and code analyzer again (cf. Section 5.6.1)
2	CAL	AUTOCAL	Automatic calibration; activation of calibration with ambient air or nitrogen
3*	PUMP	Pump	Switch internal sample gas pump on/off
4	ESC	Escape	In input mode: return by one menu level <u>or</u> cancel current input <u>or</u> cancel calibration*
5	↑	Arrow upwards	Increase selected digit; select previous menu item
6	↓	Arrow downwards	Reduce selected digit; select next menu item
7	→	Arrow to right	Move input cursor by one position to right (cyclic, i.e. the cursor is set to the left edge when the right edge has been reached)
8	ENTER	Enter	In measuring mode: switch over to input mode In input mode: import entered parameters <u>or</u> call a menu item

* The input is suppressed if certain requirements are fulfilled. A corresponding message is then output briefly on the display.

You can use the arrow keys to modify numerical values by increasing or decreasing the digit at which the cursor is located. The digits are modified continuously, i.e. 0 and 1 follow again after digit 9, and you can also decrement to 9, 8... following digit 0. The analyzer outputs the value FFF... if incorrect numbers are entered.

Use of the **MEAS**, **ESC** and **ENTER** keys is described using examples in Section 5.5. Use of the **CAL** and **PUMP** keys is described in Section 5.11.

5.3 Warm-up Mode

The analyzer can be in one of three operating modes:

- In the **warm-up mode**,
- in **measuring mode** (Section 5.4),
- or in **input mode** (Section 5.5).

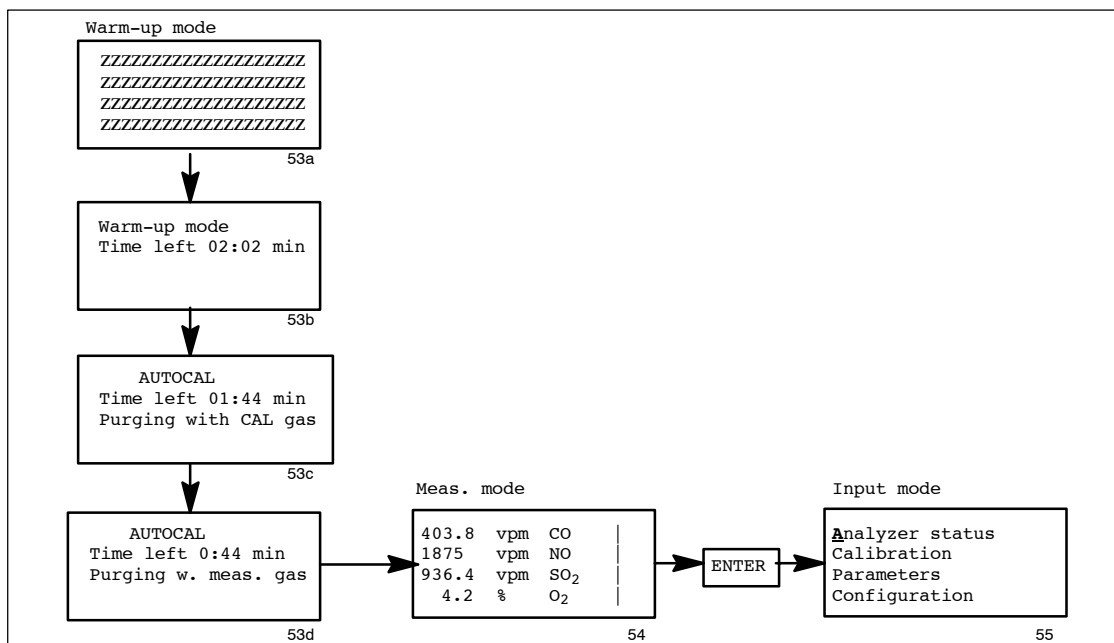
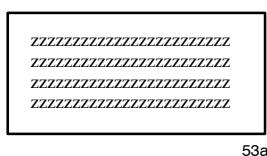
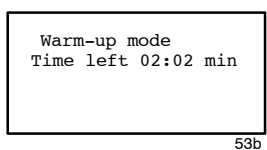

Fig. 5-32 Warm-up mode, measuring mode and input mode



Immediately following switching-on, the ULTRAMAT 23 tests the display elements. During this test, all elements light up simultaneously for approx. five seconds.



The adjacent display subsequently appears with the remaining warm-up time which is counted down in seconds to 00:00 (minutes : seconds).

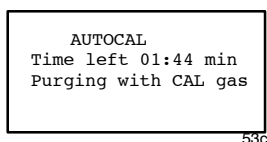

The analyzer initially carries out an AUTOCAL during the warm-up mode (see Section 4.3.1). The flow of AUTOCAL gas (nitrogen or air) is displayed in the bottom line, and the remaining time is shown in the line above this. This calibration cannot be interrupted.

```

AUTOCAL
Time left 0:44 min
Purging w. meas. gas
    
```

53d

During the last minute of the AUTOCAL, the analyzer switches to purging with sample gas.

At the end of the purging phase, the analyzer switches to measuring mode; however, full measuring accuracy is only reached after approx. 30 min if a further AUTOCAL has been carried out by the analyzer. The warm-up mode is then finished.

5.4 Measuring Mode

```

403.8 vpm CO
1875 vpm NO
936.4 vpm SO2
4.2 % O2 | P
    
```

54

The measured components are output on the display together with their values and the units in mg/m³, vpm or volume percent. With a change in the analyzer status, the corresponding letter appears in the last two columns ("P" in the example; see also Section 5.2). The analyzer remains in measuring mode until an AUTOCAL (automatic, remote-controlled or manual) is carried out or until you manually switch the analyzer to input mode (see Section 5.2).

5.5 Input Mode

In input mode, you can view instrument parameters or calibrate and parameterize the analyzer.



Caution

The analyzer must only be calibrated and/or parameterized by trained specialists and with reference to this Instruction Manual.

```

Analyzer status
Calibration
Parameters
Configuration
    
```

55

Once you have selected input mode, the first menu to appear is the **main menu** which displays four menu items. You can use these to select the individual input functions of the ULTRAMAT 23:

Analyzer status

You can call submenus which provide information on the analyzer status, e.g. entries in the logbook, diagnostics data and factory data (see Fig. 5-4 for menu structure).

Calibration

You can calibrate the zero and sensitivity of the analyzer using calibration gas (see Fig. 5-5 for menu structure).

Parameters	You can match the analyzer functions to your specific application, e.g. by entering limits, measuring ranges and time constants (see Fig. 5-6 for menu structure).
Configuration	You can define the assignments of the analyzer interfaces etc., e.g. the assignments of relays and current outputs (see Fig. 5-9 for menu structure).

5.5.1 Code Levels

The ULTRAMAT 23 is provided with two code levels to protect against unauthorized or unintentional inputs. As soon as you call a protected function for the first time, you will be requested to enter the defined three-digit code number.



Notice

You should change the codes once you have become acquainted with operation of the ULTRAMAT 23 (see Section 5.10.2.1).

The lowest code level (level 1) is factory-set to "111", and the higher level (level 2) to "222".

The following are protected by code level 1:

- The dialogs "Logbook/faults" and "Maintenance requests" in the menu "Analyzer status", submenu "Status",
- the menu "Calibration" and
- the menu "Parameters".

The following is protected by code level 2:

- The menu "Configuration".



Notice

If the analyzer requests you to enter code level 1, you can enter level 2 instead. Level 1 is then enabled simultaneously. Level 1 is automatically enabled as soon as the higher code level 2 has been enabled.

5.5.2 Key Operations Step-by-step

```
403.8 vpm CO |
1875 vpm NO |
936.4 vpm SO2 |
4.2 % O2 |
```

```
A nalyzer status
Calibration
Parameters
Configuration
```

This section describes operation of the analyzer with the keys using an example. The analyzer is in measuring mode (see Section 5.4).

- Change from measuring mode to input mode by pressing the **ENTER** key. You first access the main menu. A cursor flashes on the character "**A**" at the left edge of the first line.
- You can set the cursor to the start of each line using the ↑ and ↓ keys. Cursor movements are cyclic, i.e. if you move above the top edge of the display, the cursor appears again in the bottom line, and vice versa.
- Call the respective menu item by pressing the **ENTER** key.

```
A nalyzer status
Calibration
P arameters
Configuration
```

The cursor is located at "**P**" when you have pressed the ↓ key twice.

- Now call the submenu "Parameters" by pressing the **ENTER** key.

```
Level 1 required
Please enter code
: 000
```

The adjacent display appears in which you will be requested to enter the code number for code level 1.

- You can change the value of the code digit to which the cursor is pointing using the ↑ and ↓ keys.
- Move to the next position of the code number using the → key. This function is also cyclic, and the cursor appears at the first position again when you move it beyond the last position
- Close the code input by pressing the **ENTER** key.

```
Level 1 required
Please enter code
: 111
```

```
M easuring ranges
Limit values
Time constants
Pump/LCD contrast
```

- Press the **ENTER** key again to call the submenu "Measuring ranges".

```
Choose component
: NO 1
```

- Now select components 1 to 4 for which the subsequently set ranges are to apply. Up to four components can be present.

```
Choose component
: CO 3
```

- If your analyzer is configured accordingly, you can select another component by pressing one of the ↑ or ↓ keys, e.g. component 3 in this case.

```
Switch ranges CO
Change ranges CO
Hysteresis CO
```

- Press the **ENTER** key. The analyzer offers further menu items which you can select by pressing one of the ↑ and ↓ keys.
- Branch to the selected function by pressing the **ENTER** key.

```
Switch ranges CO
Actual range :1
MR 1:0.250 mg/m3
MR 2:0.1250 mg/m3
```

In this example, the adjacent display appears following selection of the function "Switch ranges CO". The first line contains the heading, the second line the parameter and its value to be changed; the cursor is positioned in this line. Only supplementary information is present in lines 3 and 4. To switch over the measuring range, proceed as follows:

- Press the **ENTER** key.
- The cursor jumps to the measuring range number which you can change using one of the ↑ and ↓ keys.
- The range definition is imported when you press the **ENTER** key again, and you return to the start of the line.

You cannot carry out any further settings here. To do so, you must leave the menu display again. This is possible:

- By pressing the **ESC** key, you then return by one step in the menu sequence
- By pressing the **MEAS** key. You then have the following possibilities:
 - To process the previous menu item further using **ENTER**,
 - or return to measuring mode using ↑ or → and **ENTER**, where all modifications are imported which you have made since the last decoding operation,
 - or return to measuring mode using ↓ and **ENTER** without importing the modifications.

```
Save changes?
(choose with -> )
: Yes, go to meas.
```

Once you have carried out the above sequence on the analyzer, you are already acquainted with a number of important points for operation of the ULTRAMAT 23.

5.5.3 Using the ESC key

You can trigger two different functions by pressing the **ESC** key:

Firstly, you can cancel a commenced procedure, e.g.:

- The input of a number
- A calibration procedure with calibration gas
- Any function if a fault occurs, e.g. if the flow of sample gas to the analyzer is missing.

Secondly, you can use the **ESC** key to move one level higher in submenus ("scroll back"). This procedure is the opposite to selection of a submenu using the **ENTER** key ("scroll forwards"). If you repeatedly press the **ESC** key, you return back to the main menu step-by-step. If you press the **ESC** key again in the main menu, the analyzer switches over from input to measuring mode.

An example will clarify this:

```

403.8 vpm CO      |
1875  vpm NO      |
936.4 vpm SO2     |
4.2   %   O2      | U
    
```

The analyzer is in measuring mode and is uncoded.

```

Analyzer status
Calibration
Parameters
Configuration
    
```

Switch from measuring mode to input mode using **ENTER**, select the menu item "Parameters" using the ↑ or ↓ key, and press **ENTER**.

```

Measuring ranges
Limit values
Time constants
Pump/LCD contrast
    
```

In this manner, you enter the first submenu. Press **ESC** and then **ENTER** again. You have returned by one level and then moved forwards by one level again; you are therefore in the same menu again.

```

403.8 vpm CO      |
1875  vpm NO      |
936.4 vpm SO2     |
4.2   %   O2      | U
    
```

Press the **ESC** key twice, you are back in measuring mode again.

5.6 Recoding the Analyzer

Following input of the code, inputs are possible until the analyzer is recoded.



Notice

In order to code the analyzer again when the input procedures have been finished (to protect against unauthorized and unintentional interventions), press the **MEAS** key in measuring mode.

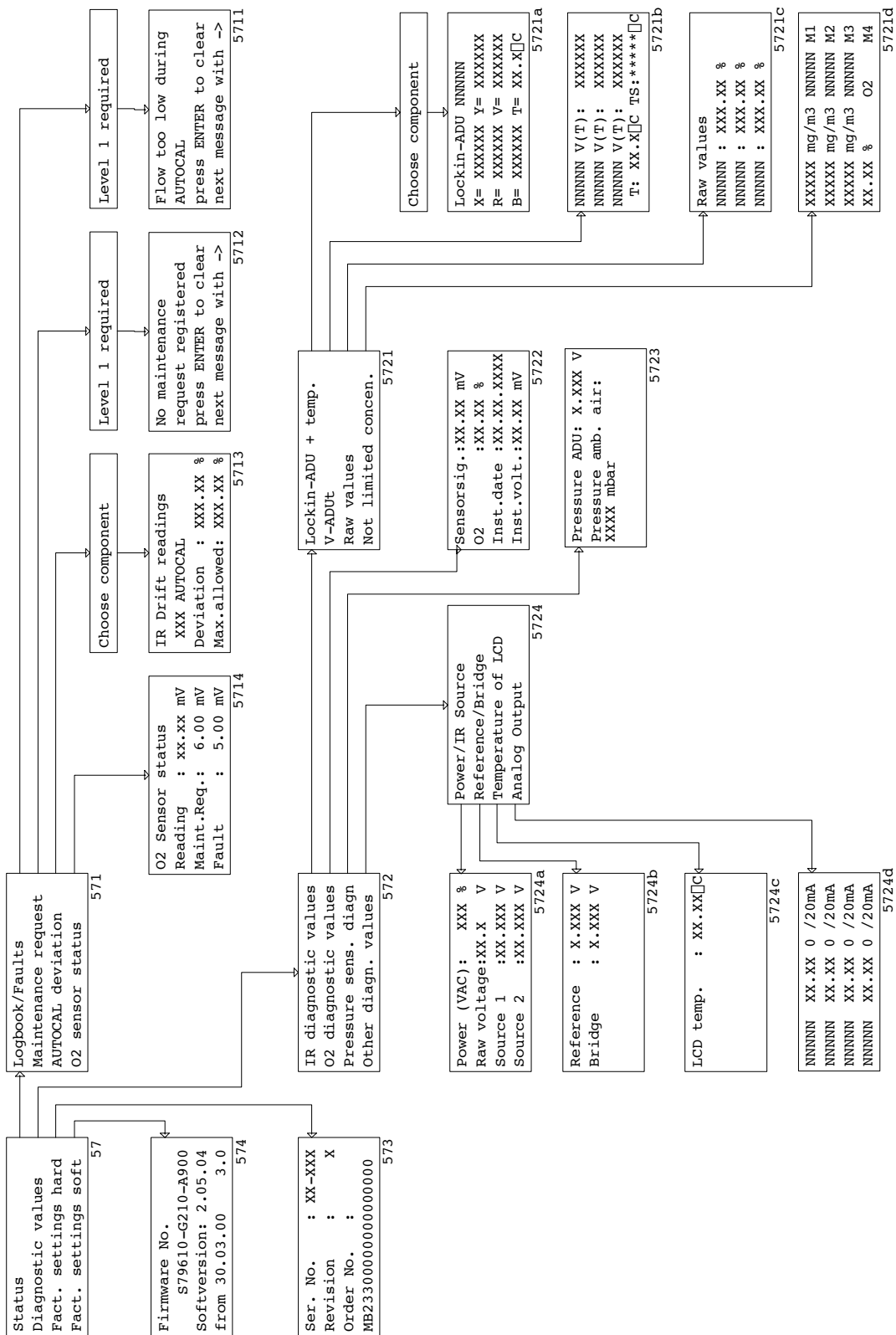

Fig. 5-42 Menu sequence for "Analyzer status"

5.7 Analyzer Status

Here you can view all analyzer data. The menu sequence in Fig. 5-4 shows all submenus which can be accessed from the menu "Analyzer status". The arrows lead by one menu item to the next lower menu/dialog level which is called by this menu item.

5.7.1 Analyzer Status: Status

```
Logbook/faults
Maintenance request
AUTOCAL deviation
O2 sensor status
```

571

In this menu you can call the status messages of the ULTRAMAT 23 via further menu items.

5.7.1.1 Analyzer Status: Status: Logbook/Faults

```
Mains voltage
beyond tolerance
Press ENTER to clear
Next message with ->
```

5711

This dialog displays a logbook of all recorded fault messages. Each type of fault message only appears once in the logbook and is output in alphanumeric text (see Chapter 6 for list of possible fault messages).

Viewing the logbook is protected by code level 1.

You can:

- **Display** all recorded faults in succession using the → key
- **Delete** the currently displayed fault message using the **ENTER** key, whereupon the next fault message appears, if present. You should delete those fault messages whose causes have been eliminated.



Notice

By deleting the fault message you do not eliminate the cause of the fault (see Chapter 6)!

- A corresponding text is output when all stored fault messages have been displayed. Terminate display of the logbook using the → key.



Notice

If the analyzer is in measuring mode, you can recognize the occurrence of a fault in that an "F" appears at the right edge. A "!" at the right edge signals that a fault has been logged which is no longer currently present.

5.7.1.2 Analyzer Status: Status: Maintenance Request

```
AUTOCAL drift
beyond tolerance
Press ENTER to clear
Next message with ->
```

5712

This dialog indicates the logged maintenance requests. A maintenance request is set if the values of certain parameters have reached defined limits, but the analyzer is still able to measure (e.g. AUTOCAL deviation or O₂ sensor status; also refer to later in this section). A corresponding message is output in alphanumeric text.

Access is protected by code level 1.

Operations in the maintenance request list (continue, delete) are carried out analogous to operations in the fault logbook.



Notice

If the analyzer is in measuring mode, you can recognize the occurrence of a maintenance request in that an "M" appears at the right edge.

5.7.1.3 Analyzer Status: Status: AUTOCAL Deviation

```
IR drift readings
1 AUTOCAL
Deviation: 2.25 %
Max. allowed: 6 %
```

5713

This dialog indicates the deviation in setpoint between two AUTOCAL procedures. The parameters has the following meanings:

- The text in the two first lines provides information on the number of AUTOCAL procedures which have been carried out since the reference values for AUTOCAL were last set (see Section 5.10.2.2).
- **Deviation** is the measured deviation of the actual value from the setpoint. This must not be above the set maximum value.
- **Max. allowed** is the maximum permissible value for the deviation. Refer to Section 5.10.2.2 to set the maximum value.

This function is specific to the component.

5.7.1.4 Analyzer Status: Status: O₂ Sensor Status

```
O2 sensor status
Reading: 12.02 mV
Maint. req: 6.00 mV
Fault: 5.00 mV
```

5714

The cell voltage of the measuring cell drops during operation as a result of the aging process of the sensor. An exact message is no longer possible if it has reached the minimum value of 5.0 mV (fault message). The O₂ measuring cell should therefore be replaced when below 6.0 mV (maintenance request).

- **Reading** is the current voltage of O₂ measuring cell
- **Maint. req** and **Fault** are the two minimum values which output a maintenance request or a fault message when fallen below.

5.7.2 Analyzer Status: Diagnostic Values

```
IR diagnostic values
O2 diagnostic values
Pressure sens. diagn
Other diagn. values
```

572

The diagnostic values which can be displayed provide important information for troubleshooting and adjustments. You can select four different function groups in this menu:

5.7.2.1 Analyzer Status: Diagnostic Values: IR Diagnostic Values

```
Lock-in ADU + temp.
V-ADUt
Raw values
Not limited concen.
```

5721

In this submenu, you can call the diagnostic values of the infrared measuring ranges:

```
Lock-in ADU SO2
X= 408399 Y= 103444
R= 444912 V= 444912
B= 10016 T= 41.0°C
```

5721a

- **ADU** are voltage and signal values of the analog-to-digital converter prior to temperature compensation. These values are specific to the component.

```
NO V(T): 440206
CO V(T): 505577
SO2 V(T): 494135
T: 42.2°C TS: *****
```

5721b

- **V-ADUt** are voltage and signal values of the analog-to-digital converter following temperature compensation. T in the bottom line corresponds to the temperature of the analyzer section, TS the temperature of the IR source (**not yet implemented**. "*****" = no measured value).

```
Raw values
NO : 1.99 %
CO : 0.27 %
SO2 : 5.08 %
```

5721c

- **Raw values** are the measured values in % of the full-scale value (= 100 %).

```
18 mg/m3 NO M1
2 mg/m3 CO M2
14 mg/m3 SO2 M3
20.93 % O2 M4
```

5721d

- **Not limited concen.** are the values as in measuring mode except that you can approximately display the concentrations here even with an upward or downward violation of the largest range. Negative values are also displayed (live zero). The current measuring range is output on this display in the last two columns.

5.7.2.2 Analyzer Status: Diagnostic Values: O₂ Diagnostic Values

```
Sensorsig: 12.02 mV
O2: 20.94 %
Date: 27.05.1996
Inst.volt.: 12.10 mV
```

5722

This dialog displays the diagnostic values of the optional oxygen sensor.

- **Sensorsig** is the current voltage of the O₂ sensor in mV
- **O₂** is the current oxygen value
- **Date** is the installation date of the O₂ sensor (see Section 5.8.2)
- **Inst.volt** is the voltage of the O₂ sensor when it was installed.

5.7.2.3 Analyzer Status: Diagnostic Values: Pressure Sensor Diagnosis

```
Pressure ADU: 3.965 V
Pressure amb. air:
999 mbar
```

5723

This dialog displays the diagnostic values of the pressure sensor (see Section 5.8.3). The displayed values have the following meaning:

- **ADU pressure** is the voltage of the pressure sensor measured at the output of the A/D converter.
- **Pressure amb. air** is the current atmospheric pressure in mbar.

5.7.2.4 Analyzer Status: Diagnostic Values: Other Diagnostic Values

```
Power/IR source
Reference/Bridge
Temperature of LCD
Analog output
```

5724

This menu is used to call further diagnostic functions. You can call the following dialogs:

```
Power (VAC) : 101 %
Raw voltage : 30 V
Source 1 : 7.541 V
Source 2 : 15.023 V
```

5724a

- **Power/IR source**
 - **Power:** Data on the mains voltage in % of the nominal value of the respective mains voltage (e.g.: 100 % corresponds to 230 V or 120 V).
 - **Raw voltage:** Raw voltage following the rectification
 - **Source 1, Source 2:** Data on the IR source voltage(s), in Volt provided the IR source is present.

```
Reference : 2.513 V
Bridge : 3.755 V
```

5724b

- **Reference/Bridge**
 - **Reference:** The reference voltage for the electronics of the analyzer.
 - **Bridge:** The supply voltage to the measuring bridge.

```
LCD temp. : 34.9°C
```

5724c

- **LCD temperature**
The temperature which determines the display contrast. Refer to Section 5.9.4.2 for adjustment of the LCD contrast.

```
NO 3.11 4 /20mA
CO 4.25 4 /20mA
SO2 4.04 4 /20mA
O2 17.82 4 /20mA
```

5724d

- **Analog output**
The value of the output voltage in Volt; (the dimension is not shown for space reasons) as well as the start-of-scale value (either 0, 2 or 4 mA) and the full-scale value (20 mA) of the output current range are displayed for each of the measured components. Refer to Section 5.10.2 for adjustment of the start-of-scale values.

5.7.3 Analyzer Status: Factory Settings Hardware

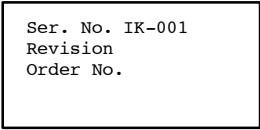

Ser. No. IK-001
Revision
Order No.

573

Factory settings are parameters which are already set on delivery and which cannot be modified by the user, such as the Serial No., revision and Order No. The hardware configuration and release version can be read here.

5.7.4 Analyzer Status: Factory Settings Software

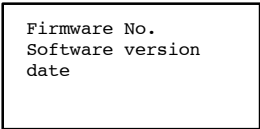

Firmware No.
Software version
date

574

Factory settings are parameters which are already set on delivery and which cannot be modified by the user, such as the software/firmware release version. The software release version can be read here.

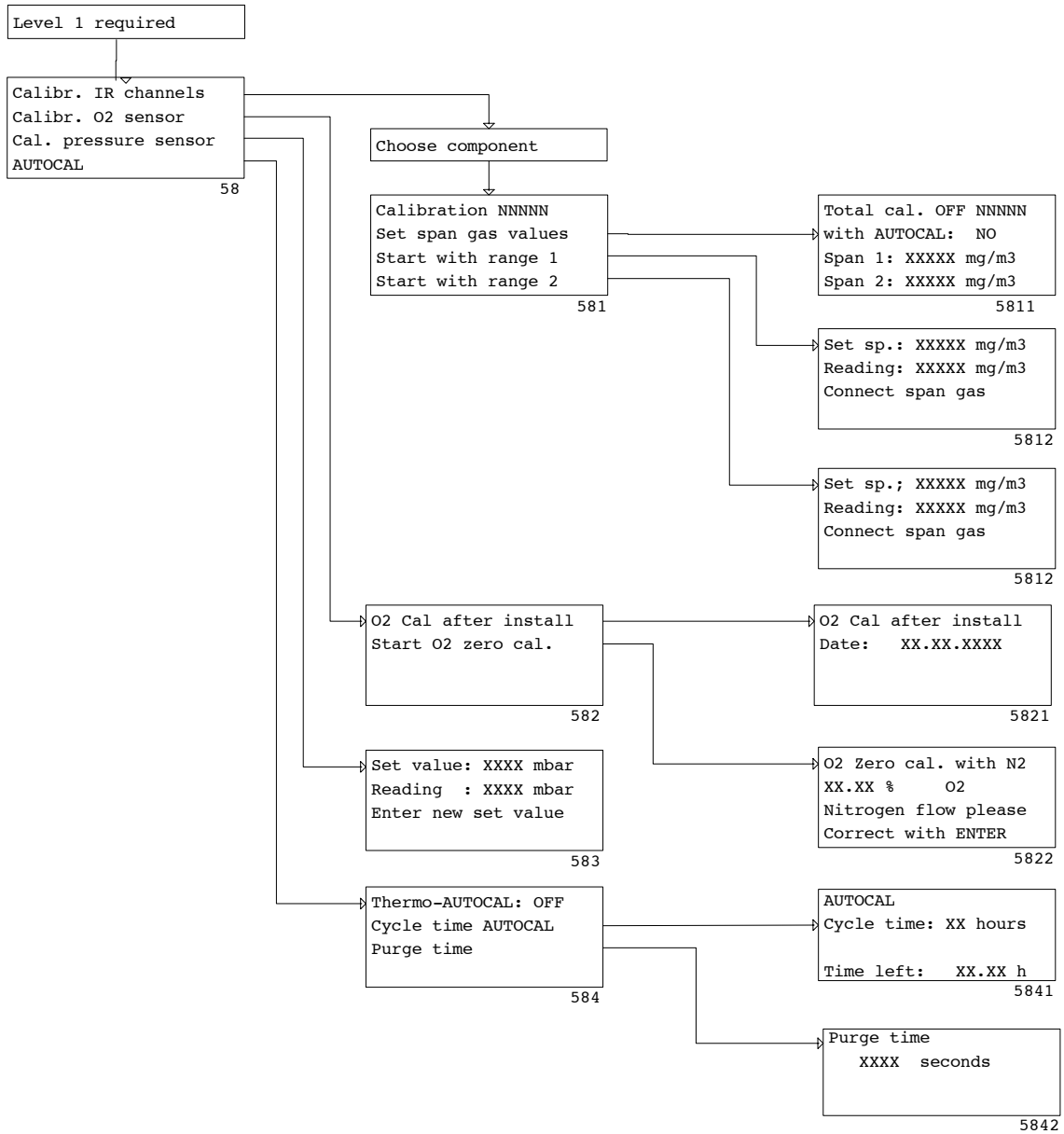

Fig. 5-52 Menu sequence for "Calibration"

5.8 Calibration

Using this function it is possible to calibrate the IR channels of the ULTRAMAT 23 using one or more calibration gases, and to reset the sensitivity. In addition, you can calibrate the oxygen sensor and the pressure sensor and also define the AUTOCAL parameters. Fig. 5-5 shows the associated menu sequence (see Section 5.7 for description of display elements).

Calibration is only possible if you have enabled code level 1.

5.8.1 Calibration: Calibrate IR Channels

```
Calibration SO2
Set span gas values
Start with range 1
Start with range 2
```

581a

In this menu you can:

- Set, in line 2, the setpoints of the calibration gases for the individual ranges or select a total or single calibration.
- Start a calibration procedure in lines 3 and 4.

This function is specific to the component.

5.8.1.1 Calibration: Calibrate IR Channels: Set Span Gas Values

```
Total cal.: OFF SO2
With AUTOCAL: NO
Span 1 : 386 mg/m3
Span 2 : 1920 mg/m3
```

5811

- **Total cal.:** In the first line of this dialog, you can select either a total or single calibration.
 - **ON** means that one range is calibrated and that this calibration is used for the other ranges (total calibration).
 - **OFF** means that each range is calibrated separately (single calibration, e.g. with different calibration gases).
- **With AUTOCAL:** You can define here whether you wish to carry out an AUTOCAL prior to the calibration procedure (**YES** or **NO**). An AUTOCAL is not necessary here if it has already been carried out shortly before the calibration procedure, e.g. a calibration procedure has taken place directly previously.
- **Span1, Span2:** Here you can enter the setpoints for the individual measuring ranges (these are the concentrations of the components in the respective calibration gas). They should be set to a value which is between 70 and 100 % of the full-scale value. If **Total cal.: ON** has been selected, the analyzer automatically uses the setpoint of range 2 for range 1. With **Total cal.: OFF** any input is possible between the start-of-scale and full-scale values of the respective range.

5.8.1.2 Calibration: Calibrate IR Channels: Start with Range MR 1/2

```
Set span: 386 mg/m³
Reading: 1 mg/m³
Connect span gas
```

5812

The analyzer interrupts the current measurement if you call one of these two dialogs. If the parameter **With AUTOCAL** was set to **OFF**, the analyzer expects an immediate flow of calibration gas; if the value is set to **ON**, an AUTOCAL is carried out prior to the flow of gas. The values of the setpoint and actual-value calibrations are displayed in the first two lines.

```
Set span: 386 mg/m³
Reading: 1 mg/m³
If the reading is
stable, press ENTER
```

5812a

If the analyzer recognizes a flow of calibration gas, the display changes as shown. If the measured value in the second line remains constant for more than approx. 10 s or does not change significantly, press the **ENTER** key.

```
Set span: 386 mg/m³
Reading: 380 mg/m³
Calibration o.k.
Press ESC to return
```

5812b

The analyzer then compares the setpoint and actual value (measured value) of the calibration. If the deviation between the values is within the tolerance, the adjacent message is output. (**o.k.**)

```
Set span: 386 mg/m³
Reading: 5 mg/m³
Tolerance not o.k.
Press ESC to return
```

5812c

If the actual value is approx. 20 % greater or smaller than the setpoint, the message **not o.k.** appears instead (no calibration possible).

5.8.2 Calibration: Calibrate O₂ Sensor

```
O2 cal. after install
Start O2 zero cal.
```

582

In this menu, you can call dialogs:

- To re-enter the installation date of the O₂ sensor
- To recalibrate the zero of the O₂ sensor.

5.8.2.1 Calibration: Calibrate O₂ Sensor: O₂ Cal. after Install

```
O2 cal after install
Date :01.01.2000
```

5821

Following the installation of a new sensor, you must re-enter the installation date.

The entered date is checked for plausibility. A calibration (AUTOCAL) is then carried out with ambient air.

A check is carried out during this procedure to establish whether the sensor voltage is greater than 9 mV. If this is not the case, a fault message "Sensor voltage too low".

5.8.2.2 Calibration: Calibrate O₂ Sensor: O₂ Zero Cal.

```
O2 zero ca. with N2
0.18 %
Nitrogen flow please
Calibrate with ENTER
```

5822

In this dialog you can recalibrate the zero point of the O₂ sensor using nitrogen. Connect a flow of nitrogen and commence the calibration using **ENTER**.

```
O2 zero cal with N2
1.25 %
>1% => default value
Press ESC to return
```

5822a

When you call the calibration function, the current oxygen value is displayed in the second line. If this does not deviate by more than 1 % from the set value, it is used as the new zero (this is not the case in the example display, see third line).

If the value is greater than 1 %, a fixed standard value is used instead.



Notice

Please note that the exchange of gas takes place very slowly with low oxygen concentrations. Purge for 30 min, and then use the current value.

5.8.3 Calibration: Calibrate Pressure Sensor

```
Set value: 1000 mbar
Reading: 1007 mbar
Enter new set value
```

583

In the first line of this dialog, you can re-enter the setpoint of the pressure sensor. Measure a value e.g. using an accurate barometer, and change the setpoint in the first line if necessary.

5.8.4 Calibration: AUTOCAL

In this dialog you can change the following values of the AUTOCAL parameters:

```
Thermo-AUTOCAL: OFF
Cycle time AUTOCAL
Purge time
```

584

- **Thermo-AUTOCAL**

- **OFF:** An automatic AUTOCAL only takes place when the cycle time has expired (see below).
- **ON:** An automatic AUTOCAL is carried out when the set cycle time has expired, and is also triggered in the case of changes in temperature > 8°C.

```
AUTOCAL
Cycle time: 6 hours
Time left 04:44 h
```

5841

- **Cycle time AUTOCAL**

A further dialog is called, and you can set and modify the cycle time (the time between two AUTOCAL procedures triggered by the analyzer) in the second line. Valid cycle times are from 0 to 24 hours. In the display, 6 hours has been set as an example. A cyclic AUTOCAL is not carried out if 0 hours is set. The cycle time must not be set > 6 h if the analyzer is used in German systems subject to TA Luft and 13.BImSchV.

The fourth line indicates when the next AUTOCAL will take place.

```
Purge time
_ 80 seconds
```

5842

- **Purge time**

If you call the menu item "Purge time", you can change the purge time (duration of flow with sample gas) in the second line of the displayed dialog. Valid purge times for analyzers with an O₂ sensor are 60 to 300 s, otherwise 0 to 300 s. There are minimum purge times depending on the measured components, and shorter times should not be used. 80 seconds has been selected in our example.

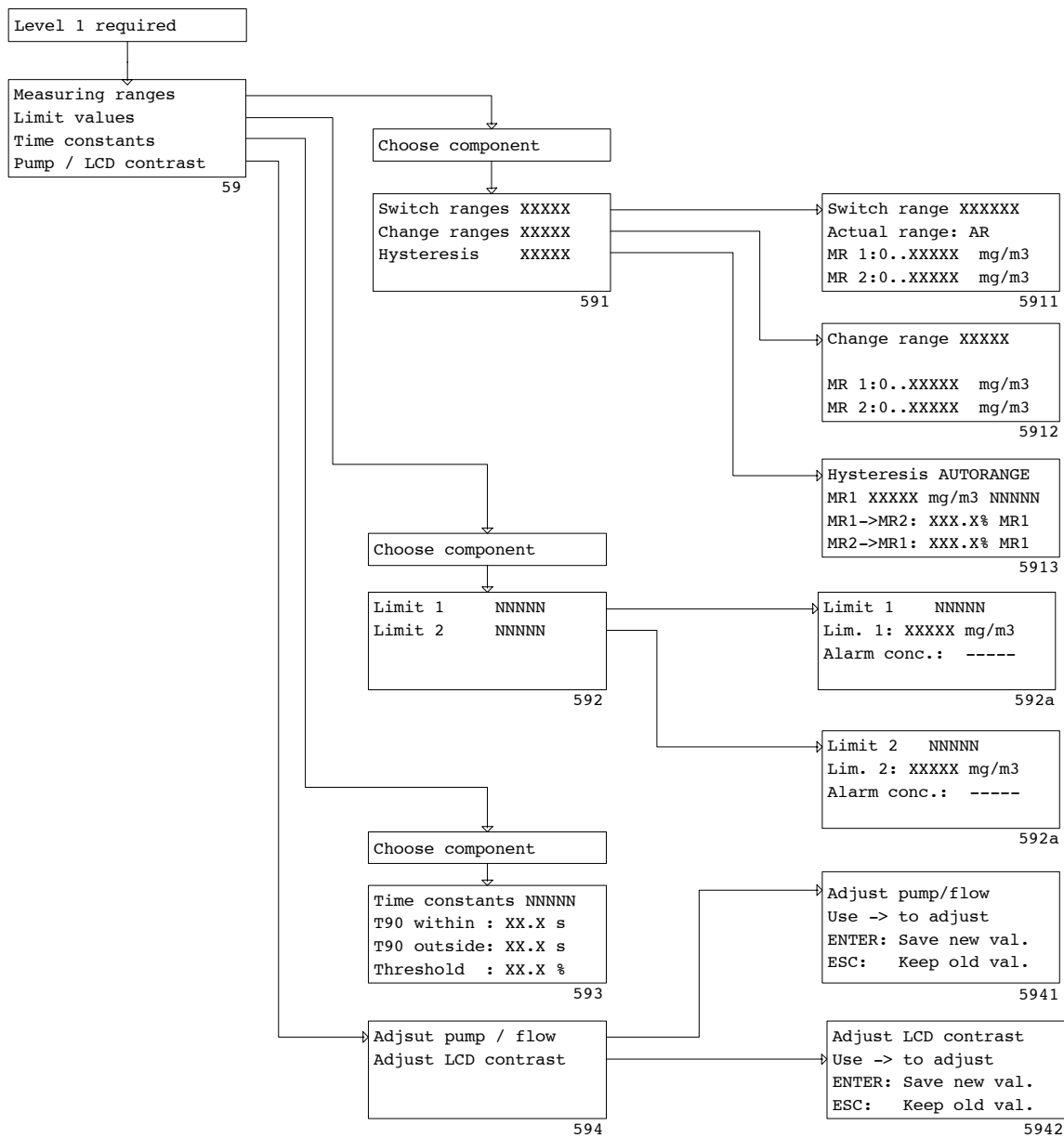

Fig. 5-62 Menu sequence for "Parameters"

5.9 Parameters

It is possible here for you to modify various analyzer parameters. These modifications can only be made within the limits which have been preset for your analyzer. The analyzer checks parameter changes for plausibility and rejects them if applicable. Fig. 5-6 shows the menu sequence (see Section 5.7 for explanation of display elements).

The menu "Parameters" is protected by code level 1.

5.9.1 Parameters: Measuring Ranges

```
Switch ranges SO2
Change ranges SO2
Hysteresis SO2
```



591

You can use this menu to select dialogs in order to permit or cancel the switching over between measuring ranges, to set the full-scale values and to define a hysteresis.

Notice

Please note that the range parameters only refer to the analog outputs (see Section 5.10). The display always shows the complete, physically possible range with the factory-set digital resolution.

5.9.1.1 Parameters: Measuring Ranges: Switch Ranges

```
Switch ranges SO2
Actual range: 1
MR 1:0.. 400 mg/m3
MR 2:0.. 2000 mg/m3
```

5911

In the second line of this dialog you can set the measuring ranges 1 or 2 or permit autoranging (automatic switching over between these two ranges). The parameter **Actual range** can have the following values:

- **1**: The analyzer is set to the smaller range (**MR 1**) and does not switch over the analog output (see Chapter 3, Pin Assignments) (see Fig.).
- **2**: The analyzer is set to the larger range (**MR 2**) and does not switch over the analog output.
- **AR**: The analyzer switches over automatically from one range to the other (AR = autorange). Refer to Section 5.9.1.3 for how to set the switch over criteria.

5.9.1.2 Parameters: Measuring Ranges: Change Ranges

Change ranges SO ₂	
MR 1:0..	400 mg/m ³
MR 2:0..	2000 mg/m ³

5912

The full-scale values of the measuring ranges can be set in the third and fourth lines of this dialog. They must be present within the factory settings, i.e. if an analyzer is factory-set for a total range from 0 to 2000 mg/m³, modifications are only possible within this range + 3 %, i.e. up to 2060 mg/m³. In addition, the full-scale value of range 1 must not be smaller than - 3 % of the factory-set minimum permissible range, e.g. not smaller than 388 mg for 400 mg, and not greater than that of range 2.

5.9.1.3 Parameters: Measuring Ranges: Hysteresis

Hysteresis AUTORANGE	
MR1	400 mg/m ³ SO ₂
MR1->MR2:	100.0% MR1
MR2->MR1:	90.0% MR1

5913



In the third and fourth lines of this dialog, you can set the value at which the analyzer switches from one range to the other. The values are specified in % of the full-scale value of range 1 (**MR1**) (see Section 5.9.1.1) .

Notice

The hysteresis is only active if the parameter **Actual range** has been set to the value **AR** (autorange) in the dialog "Switch ranges".

The two switch over points should be as far apart as possible, and the switch over point from MR1 to MR2 must be greater than that from MR2 to MR1. The following conditions have been assumed in the above display:

Your analyzer has two ranges: MR1 from 0 to 400 mg/m³, MR2 from 0 to 2000 mg/m³. The hystereses are defined as: **MR1->MR2** at 100 %; **MR2->MR1** at 90 %.

This means:

- If your analyzer is working in the smaller range (MR1), it switches over to the larger range (MR2) when a value greater than 400 mg/m³ SO₂ is measured.
- If your analyzer is working in the larger range (MR2), it switches over to the smaller range (MR1) when a value less than 360 mg/m³ SO₂ is measured (= 90 % of 400 mg/m³).

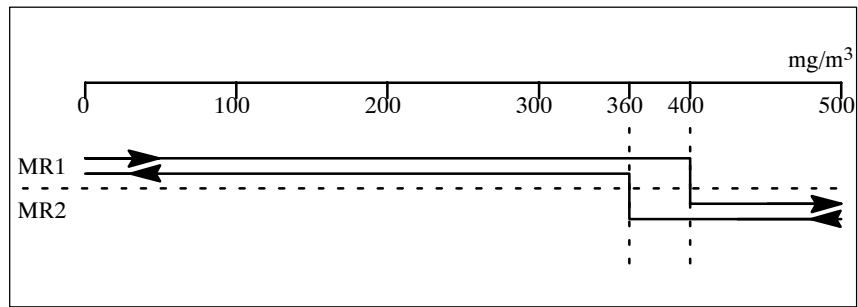

Fig. 5-72 Hysteresis curve

5.9.2 Parameters: Limit values

```
Limit 1 SO2
Limit 2 SO2
```

592



Two limits are assigned to each component, and can be set using this menu. A relay is triggered when the limits are violated (see Section 5.10.1.2). **Limit 1** is the lower limit, **Limit 2** the upper limit.

Notice

A set limit only triggers a relay contact if a relay has been assigned to the corresponding limit signal (see Section 5.10.1.2).

```
Limit 1 SO2
Limit 1: 2000 mg/m3
Alarm at conc.:-----
```

592a

If you have selected "Limit 1" or "Limit 2", a dialog appears in which you can enter the lower or upper limit for each component. You can define the value in the second line, and the condition under which a contact is be triggered in the third (**Alarm at conc.:**):

- **High:** with upward violation
- **Low:** with downward violation
- -----: no signal; see Fig.

5.9.3 Parameters: Time Constants

```
Time constant SO2
T90 within: 12 s
T90 outside: 3 s
Threshold: 3 %
```

593

You can use this function to set various time constants to suppress noise in the measured signal. During processing of the measured signals, these time constants reduce the noise by delaying the signal.

The time constant "T90 within" is effective within a parameterized interval whose threshold values are defined as a percentage of the smallest measuring range. The time constant dampens small changes in signal (e.g. noise), but becomes immediately ineffective if the signal exceeds a threshold. When this occurs, the signal is dampened by the time constant "T90 outside" until it falls below the threshold value again, whereupon "T90 within" becomes effective again.

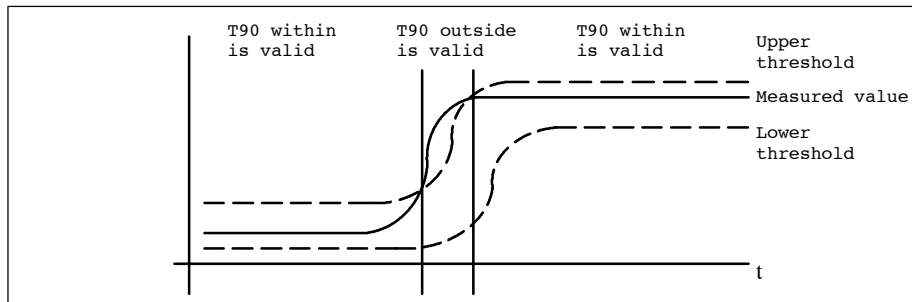

Fig. 5-82 Thresholds and time constants

The following values are possible for the time constants:

- **T90 within, outside:** 0.1 to 99.9 (s)
- **Threshold:** Data in %: 0 to 100 % of smallest range (in Fig.: 0 %).

5.9.4 Parameters: Pump/LCD Contrast

```
Adjust pump/flow
Adjust LCD contrast
```

594

You can use this menu to select two dialogs via which the pump capacity and the contrast of the LCD can be changed.

5.9.4.1 Parameters: Pump/LCD Contrast: Adjust Pump

```
Adjust pump/flow
Use -> to adjust
ENTER: save new val.
ESC: keep old value
```

5941

Here you can:

- **Increase** the pump capacity using the → or ↑ key
- **Decrease** the pump capacity using the ↓ key
- Store the set pump capacity using the **ENTER** key
- Cancel the input using the **ESC** key.

Changes to the pump capacity are shown on the flowmeter and directly in the menu display by the message OK or NOK.

5.9.4.2 Parameters: Pump/LCD Contrast: Adjust LCD Contrast

```
Adjust LCD contrast
Use -> to adjust
ENTER: save new value
ESC : keep old value
```

5942

Here you can:

- **Increase** the contrast using the → or ↑ key (darken the characters)
- **Decrease** the contrast using the ↓ key (brighten the characters)
- Store the set contrast using the **ENTER** key
- Cancel the input using the **ESC** key.



Notice

Press the three keys ↑ , ↓ and → simultaneously to set an average contrast again.

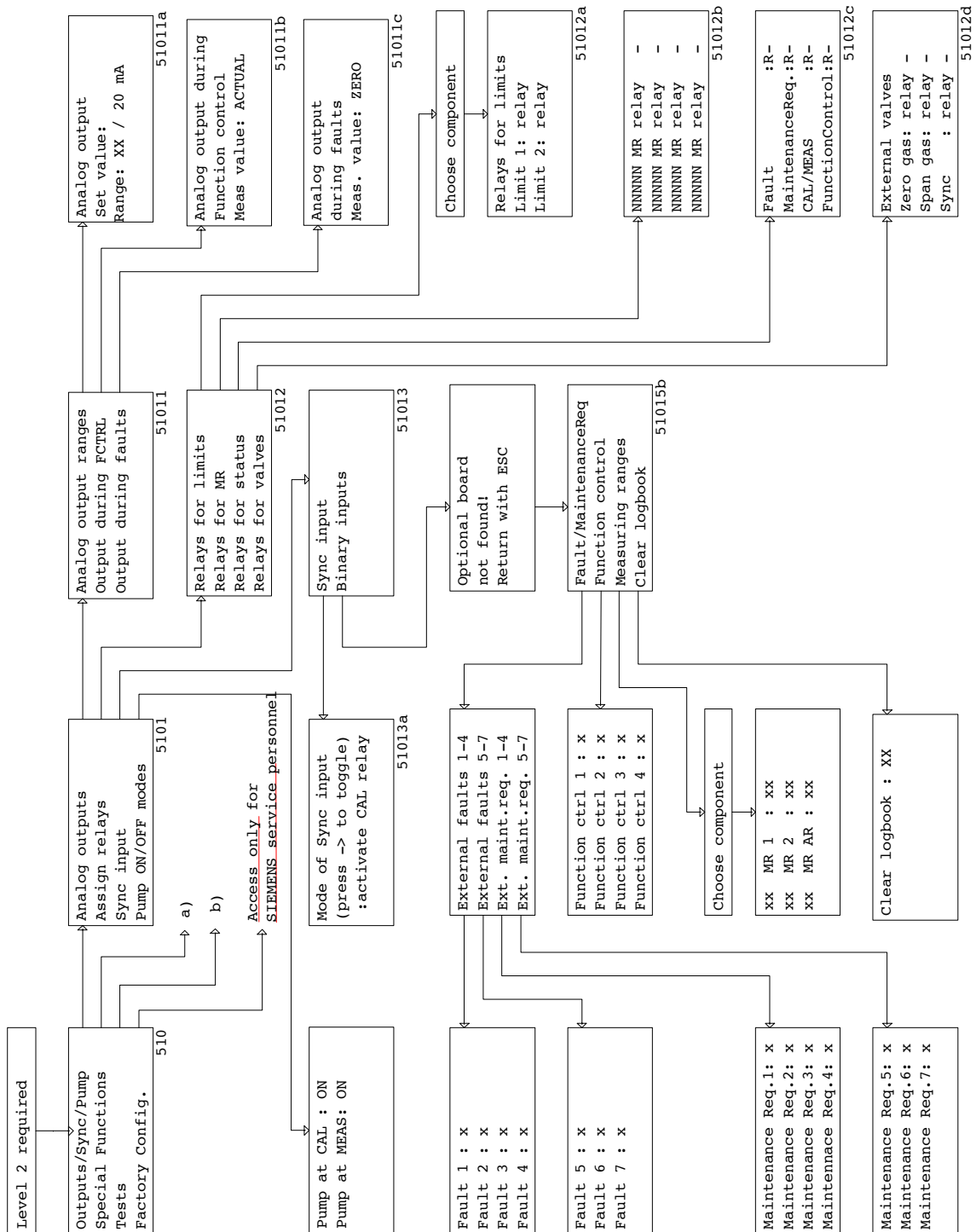

Fig. 5-92 Menu sequence for "Configuration"

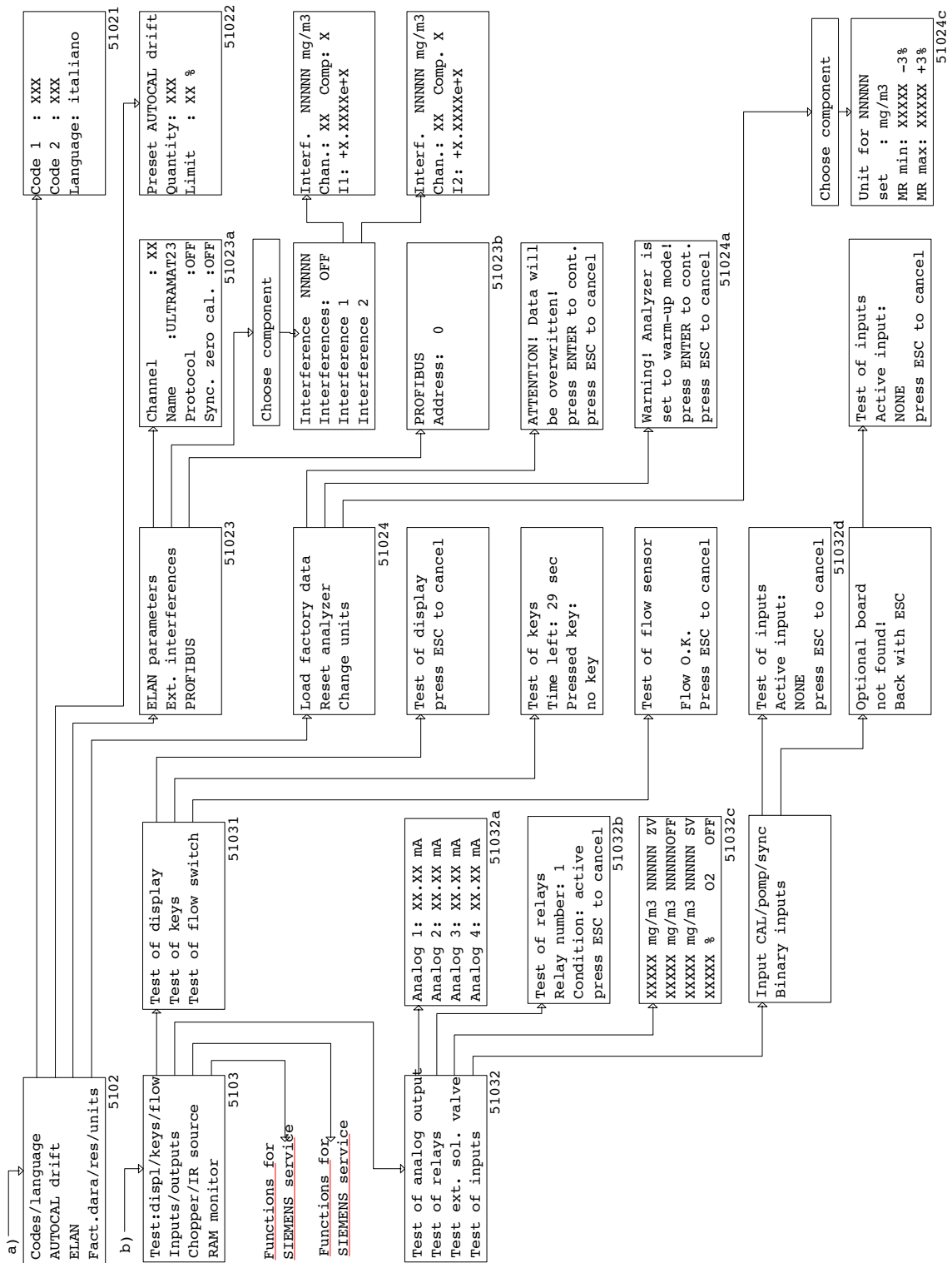

Fig. 5-102 Menu sequence for "Configuration" (continued)

5.10 Configuration

Here you can assign relays and inputs/outputs and use special functions and test functions. Fig. 5-9 shows the associated menu sequence (see Section 5.7 for explanation of elements).

This menu is protected by code level 2.

5.10.1 Configuration: Inputs/Outputs/Pump

```

Analog outputs
Assign relays
Binary-/Sync-Inputs
Pump ON/OFF modes

```

5101

This menu provides functions in order to define relays, inputs and outputs, the synchronization and the pump response during calibration and in measuring mode:

5.10.1.1 Configuration: Inputs/Outputs/Pump: Analog Outputs

```

Analog output ranges
Output during FCTRL
Output during faults

```

51011

You can use this menu to parameterize the analog output:

```

Analog output
Set value :
Range 4 / 20 mA

```

51011a

- **Analog output ranges (start-of-scale value of analog output)**
0, 2 or 4 mA can be set in the third line as the start-of-scale value of the analog current range; other values are not possible. If 2 or 4 mA are set, measured values below that are also output and appear in these cases as negative values (live zero).

In the adjacent display, the start-of-scale value of the analog current range is set to 4 mA.

```

Analog output during
function control
Meas. value: hold

```

51011b

- **Analog output during FCTRL (analog output during function control)**

The following measured-value outputs are possible with the AUTOCAL procedure, in warm-up mode and in the uncoded state:

- **Hold:** The value measured directly prior to commencement is output unchanged.
- **Actual:** The measured value is continuously updated.
- **Null:** A constant value of 0, 2, 4 mA is output
- **21 mA:** A constant value of 21 mA is output

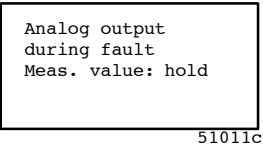

- **Output during faults (analog output during a fault)**

It is possible for you to define the type of measured-value output during a fault. The following are possible:

- **Hold:** The last value measured prior to the fault is output for the duration of the fault.
- **Actual:** The measured value is continuously updated during the fault.
- **Zero:** The measured value is set to "Zero" (0/2/4 mA) for the duration of the fault.
- **21 mA:** A constant value of 21 mA is output for the duration of the fault.

5.10.1.2 Configuration: Inputs/Outputs/Pump: Assign Relays

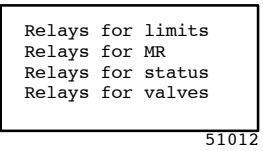

You can use this menu to assign different functions to up to eight relays which are installed in the analyzer. These functions can be signals for limits or ranges, status signals, and the functions of the external solenoid valves.

Each function may only be assigned to one single relay. The analyzer outputs an error message if you attempt a double assignment for a relay which has already been assigned. A relay to which a function has not been assigned is shown on the display by a dash.

Table 5-2 Summary of relay assignments

Function	Relay de-energized	Relay energized	Signalling
Limit	Limit has been triggered		Limit, see Section 5.9.2
Measuring range	Range 2	Range 1	
Fault	Fault present		
Maintenance request	Maintenance request		
CAL/MEAS	Measure	AUTOCAL	AUTOCAL
Function control	Function control present		With warm-up mode (approx. 30 min), AUTOCAL, uncoded
Zero gas	Zero gas flowing		Ext. solenoid valve open
Calibration gas (Sample gas inlet)		Calibration gas flowing	Ext. solenoid valve open
Sync.		Synchronization signal is output	AUTOCAL only "Zero gas flow" and adjustment not during sample gas purge phase

The pin assignments of the relays in the de-energized state are described in Chapter 3.

```
Relays/limits SO2
Limit 1: Relay 1
Limit 2: Relay 2
```

51012a

• **Relays for limits**

The upper and lower limits can be defined as events for triggering relays. Select the desired relay number in the second and third lines.

This function is specific to the component.

```
NO MR relay 3
CO MR relay -
SO2 MR relay 4
O2 MR relay -
```

51012b

• **Relays for MR**

A relay can be assigned to the range switchover of each component. This guarantees reliable assignment of the analog signal to the currently active range, especially in autorange mode (see Section 5.9.1).

Fault	:R-
Mainten. req.	:R5
CAL/MEAS	:R6
Service sw.	:R-

51012c

- **Relays for status**

You can use this dialog to apply the signalling of various operating states of the device as an event for relay control (R= Relay). The following signals are possible (see also Table LEERER MERKER):

- **Fault:** The occurrence of a fault message
- **Maintenance request:** The occurrence of maintenance request (applied to relay 5 in Fig.)
- **CAL/MEAS:** Switching over from measurement to AUTOCAL (applied to relay 6 in Fig.)
- **Service switch:** A function control is carried out.

External valves	
Zero gas	:Relay -
Span gas	:Relay 7
Sync	:Relay 8

51012d

- **External valves**

You can use this to trigger external solenoid valves via relay contacts:

- **Zero gas:** The zero gas supply which is also triggered with AUTOCAL
- **Span gas:** The calibration gas supply (assigned to relay 7 in Fig.; see Section 5.10.3.2)
- **Sync:** The synchronization with other devices within a system (assigned to relay 8 in Fig.; see Section LEERER MERKER).

5.10.1.3 Configuration: Inputs/Outputs/Pump: Binary/Sync Inputs

```

Sync inputs
Binary inputs

```

51013

```

Modes of sync input
(press -> to toggle)
_:activate CAL relay

```

51013a

You can use this dialog to set the response of the synchronization input and the binary inputs. Select an option.

- **CAL/Pump/Sync-Inputs**

You can use this dialog to set the response of the synchronization input. An AUTOCAL can then be triggered simultaneously for several analyzers within a system. The following settings are possible in the third line:

- **AUTOCAL:** The analyzer carries out an AUTOCAL and activates its sync output up to the end of the electronic adjustment.
- **Activate CAL relay** (set in Fig.): The analyzer activates its sync output, but does not carry out an AUTOCAL. The CAL output is also activated at the same time.

```

Fault/MaintenanceReq
function control
measuring ranges
Clear logbook

```

51015b

- **Binary Inputs:**

You can use this dialog to freely configure 8 floating binary inputs ["0" = 0 V (0...4,5 V); "1" = 24 V (13...33 V)] in analyzers with an option module. The pin assignments of the 37-contact plug are described in Chapter 3. No inputs are preset on delivery.

Using a submenu for the 8 inputs, you can

- switch over 7 different messages for faults/maintenance requests or
- switch over 4 different messages for function check or
- switch over measuring ranges or
- delete the logbook.

The following table explains the functions:

Table 5-3 Summary of binary inputs

Function	Control with		Effect
	0 V	24 V	
- (vacant)			
External fault 1-7		x	e.g. signalling of a fault in gas conditioning (cooler, flow, condensation trap, ...)
External maintenance request		x	e.g. signalling of a maintenance request in gas conditioning (filter, flow, ...)
Function check		x	e.g. signalling of maintenance
Measuring range 1, 2		x	The corresponding range is selected (autorange OFF)
Autorange		x	Autorange is switched on
Delete logbook		x	Delete all fault and maintenance request entries

5.10.1.4 Configuration: Inputs/Outputs/Pump: Pump at CAL/MEAS

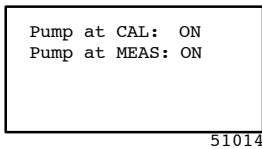

You can use this dialog to define the response of the pump. The following parameters and values are possible:

- **Pump at CAL:** Pump **ON** or **OFF** during a calibration procedure (AUTOCAL)
- **Pump at MEAS:** Pump **ON** or **OFF** during measuring mode.

5.10.2 Configuration: Special Functions

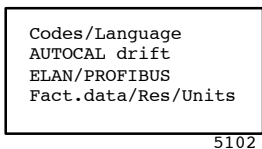

You can use this menu to call dialogs in order to modify the access code, to set the AUTOCAL drift, to parameterize the interfaces and to change the physical units in which the measured values are output.

5.10.2.1 Configuration: Special Functions: Codes/Language

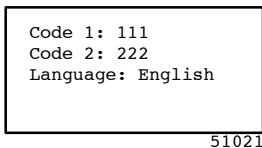

In the first two lines of this dialog, you can change the codes of the two code levels 1 and 2 (see also Section 5.5.1). The factory settings are:

- **Code 1:** 111;
- **Code 2:** 222.

You can also reduce the number of code levels by assigning the same code to both levels. The new values are saved when you subsequently switch off the ULTRAMAT 23; you should therefore make a note of the changed code numbers and keep this at a safe place.

You should note the code numbers before you leave the menu.

In third line of this dialog you can change the language of the display dialogs:

- deutsch
- English
- español
- français
- italiano
- polish

A change is immediately effective when you leave the dialog.

5.10.2.2 Configuration: Special Functions: AUTOCAL Drift

```
Preset AUTOCAL drift
Quantity: 004
Limit: 6 %
```

51022

You can use this dialog to define the conditions under which the drift of an AUTOCAL procedure triggers a maintenance request. The adjustable parameters are:

- **Quantity:** The number of AUTOCAL procedures up to setting of a new reference value (4 in this case)
- **Limit:** The highest value in % of the smallest measuring range (max. 99%) by which the calibration may deviate from the reference value (6 % in this case. See also Section 5.7.1.3).

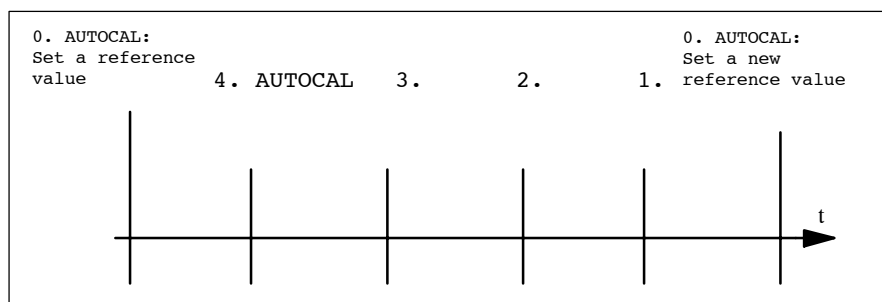
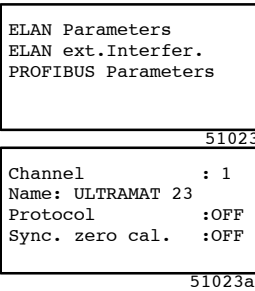

Fig. 5-112 Number of AUTOCAL procedures until a reference is set again (set number: 4)

5.10.2.3 Configuration: Special Functions: ELAN/PROFIBUS



You can use this dialog to set the parameters for an ELAN or PROFIBUS network (see Chapter 3).

- **ELAN Parameters**

You can use this dialog to set the parameters for an ELAN network (see Chapter 3).

- **Channel**

Here you can set the channel address for this analyzer. Addresses from 1 to 12 can be set. Each address may only be used once in an ELAN network.

- **Name**

You can set an analyzer name here. During communication with ELAN, it can be used for the plain text identification of the analyzers.

- **Protocol (ON/OFF)**

The cyclic, automatic transmission of measured values every 500 ms can be switched on/off.

- **Sync. zero cal. (ON/OFF)**

This function is not yet available. It must be set to OFF.



Notice

For further details on the ELAN, please refer to the ELAN interface description (C79000-B5274-C176 German/English)

- **ELAN ext. Interfer.**

Parameterization with two analyzers is used as an example.

Analyzer 1 delivers measured values, analyzer 2 uses these values for a correction calculation.

1. Connect two analyzers to the ELAN interface using a cable (see ELAN interface description (C79000-B5274-C176 Chapter 2)).
2. Access the ELAN menu, and select components.

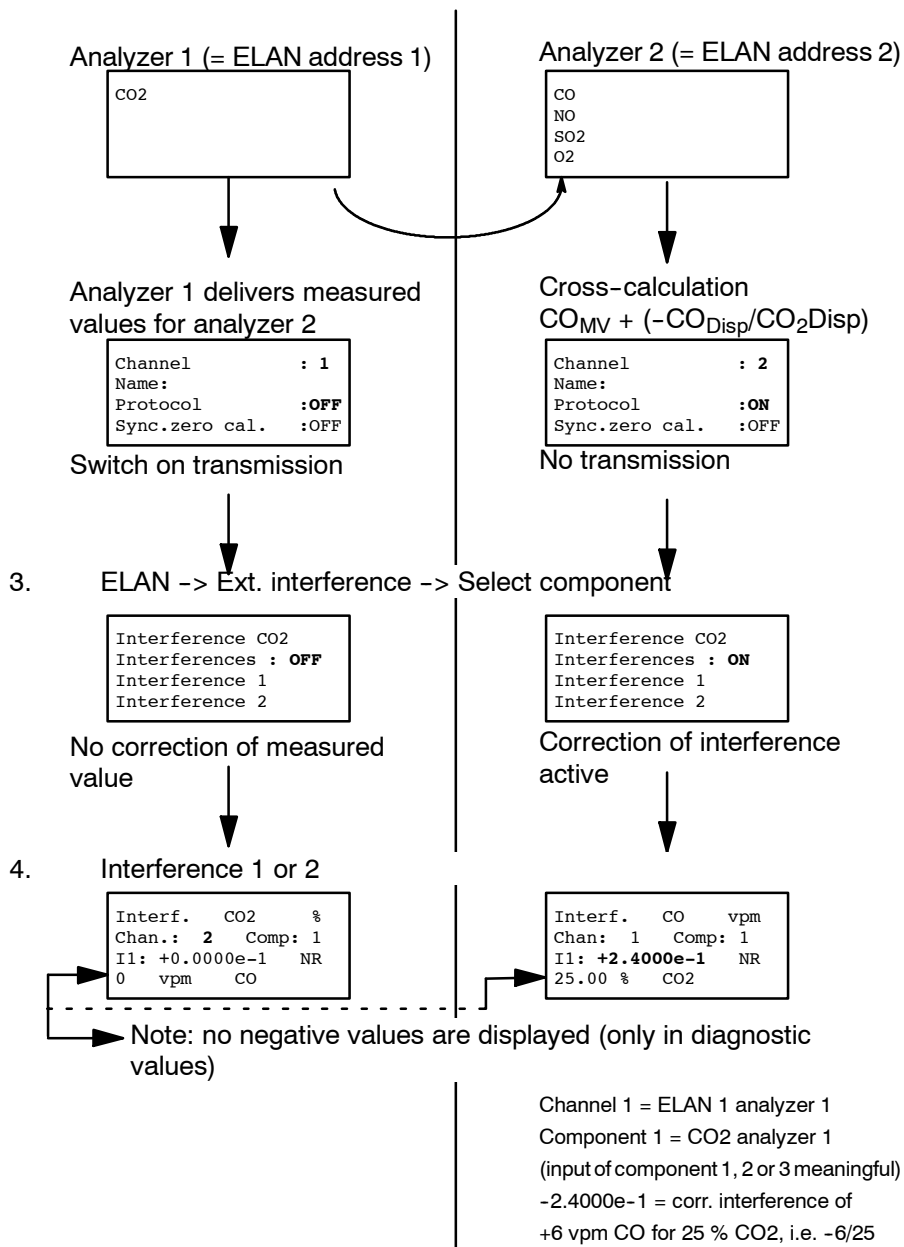

5. Neither analyzer is capable of measurements during the AUTOCAL process -> Evaluate function check (see Section 5.10.1.2)!

Fig. 5-12 ELAN external interferences

```

PROFIBUS
Number : XXX
    
```

51023b



- **PROFIBUS parameters**

If the analyzer has a PROFIBUS-PA/DP option module, you can set the station address here as a decimal number.

Notice

For further details on PROFIBUS, please refer to the PROFIBUS-PA/DP interface description (A5E00054148).

5.10.2.4 Configuration: Special Functions: Fact. data/Res/Units

```

Load factory data
Reset analyzer
Change units
    
```

51024

You can use this menu to select a number of items with which e.g. faulty configurations and analyzer settings can be cancelled:

- **Load factory data**

You can use this to reestablish the original parameters present when the analyzer was delivered. All modifications made since then are deleted.

```

Warning! Analyzer is
set to warm-up mode
Press ENTER to cont.
Press ESC to cancel
    
```

51024a

- **Reset analyzer**

You can use this function to restart the analyzer. You will be warned (see Fig.) that the analyzer runs through a warm-up mode following the restart and is thus unavailable for measurements for a certain time. The **ENTER** key starts the warm-up mode. A restart can be cancelled here if necessary using the **ESC** key.

```

Unit for SO2
Set: mg/m3
MR min: 400 -3%
MR max: 2000 +3%
    
```

51024c

- **Change units**

The second line of this dialog permits you to change the factory-set units of the measured components.

```

Unit for SO2
Set: vpm
MR min: 321 -3%
MR max: 1603 +3%
    
```

After changing the unit, the display of the parameters **MR min** and **MR max** is adapted accordingly.

This dialog is specific to the components.



Notice

The full-scale values may assume unusual values as a result of the component-specific conversion factors. Adaptations can be carried out as described in Section 5.9.1.2. Please also check the setpoints of the calibration gases (Section 5.8.1) and the settings for the limits (Section 5.9.2).

5.10.3 Configuration: Tests

```
Test:Displ/Keys/Flow
Inputs/Outputs
Chopper/IR source
RAM monitor
```

5103

You can use this test to check the selected components of the analyzer. These include the front panel keys, the LCD, inputs and outputs and a number of internal analyzer components.

5.10.3.1 Configuration: Tests: Display/Keys/Flow

```
Test of display
Test of keys
Test of flow switch
```

51031

You can select the following three tests in this menu:

- **Test of display**

All characters in the character set of this analyzer are output in succession at every position of the display. The display remains empty if characters are output which cannot be displayed. This is a cyclic test, i.e. once the complete character set has been processed, the test is repeated until terminated by pressing the **ESC** key (a message on the display will remind you of this before the test is started).

- **Test of keys**

This test takes 30 s, and the time remaining up to the end of the test is output on the display. You can press all input keys in succession during this test; the analyzer recognizes that a key has been pressed and indicates this. This test cannot be cancelled before the 30 s have expired.

- **Test of flow switch**

This indicates whether the flow is correct or not. The flow can be switched on and off by pressing the **PUMP** key.

5.10.3.2 Configuration: Tests: Inputs/Outputs

```
Test analog outputs
Test of relays
Test ext. sol. valve
Test of inputs
```

51032

The electric inputs and outputs of the analyzer are tested here. You require the following equipment to carry out these tests:

- Ammeter,
- Ohmmeter,
- Power supply and/or
- Test plugs.

You can carry out the following tests:

```

Analog 1: 0.20 mA
Analog 2: 0.40 mA
Analog 3: 1.55 mA
Analog 4: 2.60 mA
    
```

51032a

- **Test analog outputs**

You can use this dialog to set any value of the output current between 0 and 20 mA. There are four analog outputs (0/4 to 20 mA). To test these outputs, connect an ammeter to the corresponding analog outputs on plug X80 and measure the output current.

Please refer to Chapter 3 for the pin assignments of plug X80.

```

Test of relays
Relay number 1
Condition: inactive
Press ESC to cancel
    
```

51032b

- **Test of relays**

You can use this dialog to select a relay for testing. There are eight relays whose contacts you can test. Connect a ohmmeter to the corresponding relay outputs on plug X80. You can process the following parameters:

- **Relay number:** One of the relays 1 to 8 (for analyzers with option module: relays 1 to 16) or "-" (no relay)
- **Condition:** The current state of the selected relay (**active** or **inactive**; inactive in the Fig.).

Please refer to Chapter 3 for the pin assignments of plug X80/X50.

```

130 mg/m³ NO ZV
89 mg/m³ CO OFF
249 mg/m³ SO₂ SV
20.77 % O₂ OFF
    
```

51032c

- **External solenoid valve**

You can use this dialog to trigger external solenoid valves for the zero and calibration gas supplies via the relay contacts. Use the arrows keys ↑ and ↓ to select either the zero gas valve (**ZV**) in the first line and the calibration (span) gas valve (**SV**) in the third line. Call the selected valve using the **ENTER** key. Switch the previously assigned relay using any arrow key in the second or fourth line (the value on the right toggles between **OFF** and **ON**). The measured values output on the display during this test usually change following the switching operation.

```

Test of inputs
Press ESC to cancel
Active input:
None
    
```

51032d

- **Test of inputs (binary test)**

After calling this dialog, apply a voltage of 24 V to one of the three inputs "Pump ON/OFF", "CAL" or "SYNC". The result is displayed in the fourth line (no input in this case).

The external binary inputs of analyzers with option module can be tested in the menu "Binary inputs" (see Section 5.10.1.3).

5.10.3.3 Configuration: Tests: Chopper/IR Source

You can use this function to switch the chopper and IR source off.



Warning**Important! Essential!**

The analyzer is not ready for measurements if the IR source or chopper has been switched off! Depending on the switch-off period, you must therefore provide a sufficiently long warm-up mode (e.g. by restarting the analyzer).



Notice

This function must only be carried out by qualified servicing engineers.

5.10.3.4 Configuration: Tests: RAM Monitor

Servicing engineers can use this function to view the contents of certain memory areas.

5.10.4 Configuration: Factory Configuration

```
Factory config. !
Please enter special
code: 0000
```

5104

These are factory settings made especially for your analyzer. Since modifications to these parameters may influence the functions of your analyzer, access to these factory settings is only possible by servicing engineers using a special access code.

5.11 Other Inputs

5.11.1 PUMP Key

This key switches the internal, sample gas pump (if present) on and off. If the pump is switched off whilst the analyzer is in input mode, it is also switched on again by pressing the **MEAS** key if parameterized accordingly (see Section 5.10.1.4).

The pump can also be switched on and off via the binary input (see Chapter 3). The binary input has priority over the button.

5.11.2 CAL Key

If the analyzer is in measuring mode, pressing the **CAL** key triggers a single, automatic calibration with ambient air or nitrogen (AUTOCAL). The **CAL** key cannot be used during the warm-up mode.

Maintenance

6

6.1	Messages	6-2
6.1.1	Maintenance Requests	6-2
6.1.2	Fault Messages	6-3
6.2	Maintenance Work	6-6
6.2.1	Replacement of O ₂ Sensor	6-7
6.2.2	Replacement of Fuse	6-7
6.2.3	Replacement of Safety Filter	6-8
6.2.4	Emptying the Condensation Trap	6-8
6.2.5	Replacement of Coarse Filter	6-8
6.3	Maintenance of Gas Path	6-9
6.4	Cleaning the Analyzer	6-9

6.1 Messages

The ULTRAMAT 23 can detect and display various fault statuses. The fault statuses are divided into maintenance requests and fault messages.

6.1.1 Maintenance Requests

Maintenance requests are references to certain changes in the analyzer which – at the time they are made – have no influence on the analyzer measurements. However, remedial measures are recommended to guarantee that measurements remain possible.

If the analyzer is in measuring mode, the occurrence of a maintenance request is indicated by an "M" at the right edge of the display.

AUTOCAL-drift beyond tolerance
press ENTER to clear
next message with ->

Maintenance requests are logged and can be called in input mode using the menu path "Analyzer status – Status – Maintenance requests" (see Section 5.7.1.2). The corresponding message texts are stored. You can delete the messages by pressing the **ENTER** key. However, they appear again if the cause has not been eliminated.

The analyzer outputs a maintenance request in the following three cases:

AUTOCAL drift beyond tolerance

Message "AUTOCAL drift beyond tolerance"
The zero drift of a component is too large during the AUTOCAL procedure. The calibration parameters can be entered as described in Section 5.8.4. The actual deviation from the maximum permissible value can be read using the AUTOCAL deviation (see Section 5.10.2.2). It may be meaningful to set a shorter interval between two AUTOCAL procedures, otherwise contact the servicing department.

O₂ Sensor

Message "O₂ sensor"
The measuring voltage of the O₂ sensor has dropped as a result of aging, but is still within the permissible range. This means that it is not necessary to replace the O₂ sensor immediately, but this will soon be used up. Order a new O₂ sensor if necessary.

LCD temperature beyond tolerance

Message "LCD temperature beyond tolerance"
The contrast control is no longer guaranteed if the LCD temperature is outside the permissible tolerance. It may then be difficult to read the display.

The ambient temperature is too high, provide sufficient ventilation or air conditioning. If the fault still occurs, contact the servicing department.

6.1.2 Fault Messages

Fault messages are references to certain changes in the analyzer which influence its ability to measure correctly.

If the analyzer is in measuring mode, the occurrence of a fault is indicated by an "F" at the right edge of the display.

Mains voltage beyond tolerance
press ENTER to clear
next message with ->

Fault messages are logged and can be called in input mode using the menu path "Analyzer status - Status - Logbook/faults" (see Section 5.7.1.1). The corresponding message texts are stored as alphanumeric text in the logbook. You can delete the messages by pressing the **ENTER** key. However, they appear again if the cause has not been eliminated.

Table 6-1 provides a summary of fault messages, their causes, and measures to eliminate the faults. If a remedy is not listed, you must contact the servicing department when this fault message occurs.

Table 6-1 Fault messages

Fault message	Possible causes	Remedy
Meas. value channel 1 beyond tolerance Meas.-value display: *****	Analyzer section of first component is faulty	
Meas. value channel 2 beyond tolerance Meas.-value display: *****	Analyzer section of second component is faulty	
Meas. value channel 3 beyond tolerance Meas.-value display: *****	Analyzer section of third component is faulty	
Meas. value O ₂ beyond tolerance Meas.-value display: *****	O ₂ sensor faulty or old	Replace the O ₂ sensor as described in Section 6.2.1.
	Motherboard faulty	
Mains voltage beyond tolerance	Mains voltage varies	Correct such that the mains voltage is within the tolerance values permissible for the analyzer.
	Power supply unit faulty	
Temp. of analyzer beyond tolerance	Ambient temperature too high or too low	Provide sufficient ventilation or air conditioning.
	Temperature sensor of a detector faulty	
Pressure of amb. air beyond tolerance	Pressure sensor faulty	

Table 6-1 Fault messages

Fault message	Possible causes	Remedy
Flow too low during measuring	Sample gas path blocked or leaky	Clean or replace the blocked parts (hose, filter etc.). If the problem is still present:
	Pump not running	Switch the pump on.
	Pump capacity too low	Increase the pump capacity as described in Section 5.9.4.1.
	Pump faulty	
No data for temperature compensation	Temperature compensation not completed successfully	
	New components have been loaded	
	EEPROM has been initialized	
Flow too low during AUTOCAL	CAL gas path blocked or leaky	Clean or replace the blocked parts (hose, filter etc.). If the problem is still present:
	Pump not running	Switch the pump on.
	Pump capacity too low	Increase the pump capacity as described in Section 5.9.4.1.
	Pump faulty	
Conc. of O ₂ too low during AUTOCAL Meas.-value display: *****	O ₂ sensor faulty or old	Replace the O ₂ sensor as described in Section 6.2.1.
	O ₂ sensor zero not calibrated	Calibrate the zero of the O ₂ sensor as described in Section 5.8.2.2.
Fault at analog output	Component could not be initialized when switching on	
	Limits were violated when calibrating the analog section	
General fault of all IR channels MV-C1/2/3 beyond tolerance	Chopper faulty	
	IR source faulty	
Fault of addresses for IR channels	Plug-in jumper on detector for detection of components not OK	
	The cable of the detector has no contact	Check that the plug is correctly connected to the detector (the plug must latch in twice).
	Cable of detector faulty	

Table 6-1 Fault messages

Fault message	Possible causes	Remedy
AUTOCAL drift beyond tolerance	Sample cell contaminated	
	Detector faulty	
	IR source power too low	
Fault at EEPROM	Checksum not OK	
	Read character \neq written character	
Phase not found	Chopper maladjusted	
IR channel 1 not calibrated	Calibration of full-scale value/sag missing	
IR channel 2 not calibrated	Calibration of full-scale value/sag missing	
IR channel 3 not calibrated	Calibration of full-scale value/sag missing	
Voltage for IR source beyond tolerance	IR source not OK	
	Motherboard faulty	
Supply of bridge beyond tolerance	Channel amplifier faulty	
	Motherboard faulty	
Half-bridge voltage beyond tolerance	Channel amplifier faulty	
	Motherboard faulty	
Lock-in fault	Channel amplifier faulty	
	Motherboard faulty	
Sensitivity of O ₂ sensor too low	O ₂ sensor faulty or old	Replace the O ₂ sensor as described in Section 6.2.1 .
Overflow of AD converter	Electronics faulty	

6.2 Maintenance Work



Warning

Certain parts in this electrical device contain dangerous voltage during operation.

Severe personal injury and/or damage to property may occur if the power supply is connected incorrectly, if maintenance work is carried out incorrectly, or if the warnings are not observed.

Correct and safe operation of this device is dependent on proper transport, storage and installation as well as careful operation and maintenance.



Warning

When working with toxic gases, ensure that no concentrations dangerous to health can occur at the position of work. If the gas connections are made incorrectly, accidents may occur as a result of toxic, flammable or explosive gases.



Caution

The electronic components and modules fitted in this device must be protected against electrostatic charges and discharging. Comprehensive measures must therefore be made to protect them wherever they are manufactured, tested, transported and installed.



Warning

Before opening the analyzer, disconnect all poles from the mains supply.

6.2.1 Replacement of O₂ Sensor



Warning

Danger of burns

The O₂ sensor contains acetic acid which can burn unprotected skin. The sensor housing must not be damaged when the sensor is replaced.

If you nevertheless come into contact with the acid, immediately rinse affected skin with plentiful amounts of water.

Please also note that old or faulty O₂ sensors are toxic waste and must be packed and disposed of accordingly!

Removal

- Unscrew the two screws of the front cover and remove the cover.
- Unlock the plug of the sensor connection, and remove.
- Unscrew the O₂ sensor.
- Remove the gasket of the O₂ sensor.

Installation

- Insert the new gasket.
- Screw in the new O₂ sensor and tighten.
- Reconnect the plug.
- Enter the date of installation in the menu item "O₂ cal. after install" as described in Section 5.8.2.1.
- Calibrate the O₂ zero as described in Section 5.8.2.2.

6.2.2 Replacement of Fuse

- Remove the fuse holder underneath the appliance plug (see Section 3, Technical Description, Fig. 3.12 or 3.13). Use a small screwdriver to do this.
- Remove the blown fuse from the holder.
- Insert a new fuse.



Note

Only fuses of the type printed on the rear of the analyzer may be used.

- Insert the fuse holder into the compartment again.

6.2.3 Replacement of Safety Filter

Preparation

- Unscrew the four screws of the top housing cover, and remove the cover to the rear.
- Find the contaminated filter according to its type (see Section 7, spare parts list, page 7-18, pos. 14 and 15).
- Remove the hoses from the filter.
- Replace the contaminated filter.



Note

When installing the filter, make sure that the arrow on the filter points in the gas flow direction.

- Push the cover back onto the housing and screw tight.

6.2.4 Emptying the Condensation Trap (Benchtop Unit Only)

- Switch of the pump by pressing the **PUMP** key.
- Loosen the condensation trap on the front of the analyzer by tilting it slightly, and pull downwards carefully.
- Empty the trap and dispose of the condensation according to the composition of the sample gas.
- Push the condensation trap on again from below.

6.2.5 Replacement of Coarse Filter (Benchtop Unit Only)

- Switch of the pump by pressing the **PUMP** key.
- Loosen the condensation trap on the front of the analyzer as described in Section 6.2.4.
- Remove the contaminated filter.
- Insert the new filter.
- Push the condensation trap on again from below.

6.3 Maintenance of Gas Path

Depending on the corrosivity of the sample gas, check the state of the gas path at regular intervals.

Replace the hoses as necessary.

6.4 Cleaning the Analyzer

Wipe the outer surfaces of the analyzer using a soft cloth dampened with a solution of mild cleaning agent.

Spare Parts List

7

Wir haben den Inhalt der Druckschrift auf die Übereinstimmung mit der beschriebenen Hard- und Software geprüft. Dennoch können Abweichungen nicht ausgeschlossen werden, so daß wir für die vollständige Übereinstimmung keine Gewähr übernehmen. Die Angaben in dieser Druckschrift werden jedoch regelmäßig überprüft, und notwendige Korrekturen sind in den nachfolgenden Auflagen enthalten. Für Verbesserungsvorschläge sind wir dankbar.

We have checked the contents of this manual for agreement with the hardware and software described. Since deviations cannot be excluded entirely, we cannot guarantee full agreement. However, the data in this manual are reviewed regularly and any necessary corrections are included in subsequent editions. Suggestions for improvement are welcomed.

Nous avons vérifié la concordance du contenu de ce document avec les caractéristiques du matériel et du logiciel. Toutefois des divergences ne sont pas à exclure ce qui ne nous permet pas de garantir une conformité intégrale. Les informations contenues dans ce document sont régulièrement vérifiées, et les indispensables corrections apportées dans les éditions suivantes. Nous vous remercions pour toutes propositions visant à améliorer la qualité de ce document.

© Copyright Siemens AG - 2001 - All Rights reserved

Technische Änderungen vorbehalten

Technical data subject to change

Sous réserve de modifications techniques

Weitergabe sowie Vervielfältigung dieser Unterlage, Verwertung und Mitteilung ihres Inhalts nicht gestattet, soweit nicht ausdrücklich zugestanden. Zuwiderhandlungen verpflichten zu Schadenersatz. Alle Rechte vorbehalten, insbesondere für den Fall der Patenterteilung oder GM-Erteilung.

The reproduction, transmission or use of this document or its contents is not permitted without express written authority. Offenders will be liable for damages. All rights, including rights created by patent grant or registration of a utility model or design, are reserved.

Une diffusion ou une reproduction de ce document ainsi qu'une publication ou une exploitation de son contenu ne sont pas autorisés. Toute infraction conduit à des dommages et intérêts. Tous droits réservés, en particulier pour le cas des brevets d'invention délivrés ou des modèles déposés.

Diese Ersatzteilliste entspricht dem technischen Stand Januar 2001.
 This Parts List corresponds to the technical state of January 2001.
 Cette liste de pièces de rechange correspond au niveau technique de
 Janvier 2001.

Am Typenschild ist das Baujahr des Gasanalysengerätes
 (verschlüsselt) aufgeführt.
 The rating plate shows the year of construction (coded) of the gas
 analyzer.
 La plaque signalétique de l'analyseur indique l'année de fabrication
 (codifiée) de l'appareil.

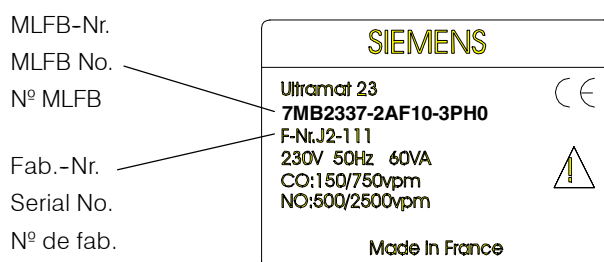

Hinweis für die Bestellung

Die Ersatzteilbestellung muß enthalten:

1. Menge
2. Bezeichnung
3. Bestell-Nr.
4. Gerätename, MLFB- und Fab.-Nr. des Gasanalysengerätes, zu dem das Ersatzteil gehört.

Bestelladresse: Siemens AG
 CSC (Centre Service Client)
 1, chemin de la Sandlach
 F-67506 Haguenau/Frankreich
 Tel.: +33 3 88 90 66 77
 Fax: +33 3 88 90 66 88

Ordering instructions

All orders should specify the following:

1. Quantity
2. Designation
3. Order No.
4. Name of gas analyzer, MLFB No. and Serial No. of the instrument to which the spare part belongs.

Ordering address: Siemens AG
 CSC (Centre Service Client)
 1, chemin de la Sandlach
 F-67506 Haguenau/France
 Tel.: +33 3 88 90 66 77
 Fax: +33 3 88 90 66 88.

Indications lors de la commande

La commande de pièces de rechange doit comporter:

1. Quantité
2. Désignation
3. N° de référence
4. Nom, N° MLFB et N° de fabrication de l'analyseur de gaz pour lequel est destiné la pièce de rechange.

L'adresse de commande: Siemens AG

CSC (Centre Service Client)

1, chemin de la Sandlach

67506 Haguenau

Tel.: +33 3 88 90 66 77

Fax: +33 3 88 90 66 88.

Bestellbeispiel:

1 Sauerstoffsensor

C79451-A3458-B55

für ULTRAMAT 23

Typ 7MB2337-2AF10-3PH0

Fab.-Nr. J2-111

Example for ordering:

1 oxygen sensor

C79451-A3458-B55

for ULTRAMAT 23

type 7MB2337-2AF10-3PH1

Serial No. J2-111

Exemple de commande:

1 capteur d'oxygène

C79451-A3458-B55

pour ULTRAMAT 23

type 7MB2337-2AF10-3PH2

N° de fab. J2-111

Allgemeiner Hinweis

Für den Austausch von Teilen sind spezielle Arbeiten notwendig. Das Servicehandbuch für den ULTRAMAT 23 gibt Ihnen hierzu die notwendige Unterstützung. Es kann unter den nachfolgenden Nummern im CSC in Haguenau bezogen werden.

C79000-W5200-C157 (deutsch)
bzw. C79000-W5276-C157 (englisch)

General information

Special work is required to change parts. The Service Manual for the ULTRAMAT 23 provides you with the necessary support for this. It can be ordered from the CSC in Haguenau under the following numbers.

C79000-W5200-C157 (German)
or C79000-W5276-C157 (English)

Remarque générale

Des travaux spéciaux sont nécessaires pour le remplacement des pièces. Le manuel de service de l'ULTRAMAT 23 vous fournit le soutien nécessaire à ce sujet. Il peut être obtenu sous les numéros suivants dans le CSC à Haguenau.

C79000-W5200-C157 (allemand)
ou C79000-W5276-C157 (anglais).

Hinweis zur Meßgenauigkeit

Um die Meßgenauigkeit des ULTRAMAT 23 zu erhalten, kann es nach dem Austausch von Teilen notwendig werden, eine Temperaturkompensation durchzuführen. Entsprechende Teile sind mit einem *) gekennzeichnet.

Dies ist besonders dann der Fall, wenn am Aufstellungsort kurzzeitige Temperaturschwankungen $>5\text{ °C}$ auftreten. Durch einen zyklischen Nullpunktgleich "AUTOCAL" von zum Beispiel 3 Stunden wird diese Temperaturabhängigkeit nicht in Erscheinung treten.

Wir empfehlen, eine Temperaturkompensation im CSC in Haguenau durchführen zu lassen. Sollte dies nicht möglich sein, bietet Ihnen das Servicehandbuch für den ULTRAMAT 23 hierzu die notwendige Unterstützung. Es kann unter den nachfolgenden Nummern im CSC in Haguenau bezogen werden.

C79000-W5200-C157 (deutsch)
bzw. C79000-W5276-C157 (englisch)

Note of the measuring accuracy

To maintain the measuring accuracy of the ULTRAMAT 23 it may be necessary to perform temperature compensation after changing parts. The appropriate parts are marked by *).

This is particularly the case when brief temperature fluctuations >5 °C occur at the erection site. This temperature dependence will not occur for example after a cyclic zero point adjustment "AUTOCAL" of 3 hours.

We recommend having temperature compensation performed in Haguenau. If this is not possible, the Service Manual for the ULTRAMAT 23 offers you the necessary support. It can be ordered from the CSC in Haguenau under the following numbers.

C79000-W5200-C157 (German)
or C79000-W5276-C157 (English)

Remarque concernant l'exactitude des mesures

Il peut s'avérer nécessaire après le remplacement des pièces de procéder à une compensation de la température afin de conserver l'exactitude des mesures de l'ULTRAMAT 23. Les pièces correspondantes sont mises en évidence par un astérisque *).

Ceci est particulièrement le cas si de courtes variations de température supérieures à 5 °C surgissent sur le lieu d'implantation. Cette dépendance de la température n'apparaît pas grâce à un réglage cyclique du point zéro "AUTOCAL" de 3 heures par exemple. Nous recommandons de faire exécuter une compensation de température dans le CSC à Haguenau.

Si cela devait être impossible, le manuel de service de l'ULTRAMAT 23 vous fournit le soutien nécessaire à ce sujet. Il peut être obtenu sous les numéros suivants dans le CSC à Haguenau.

C79000-W5200-C157 (allemand)
ou C79000-W5276-C157 (anglais).

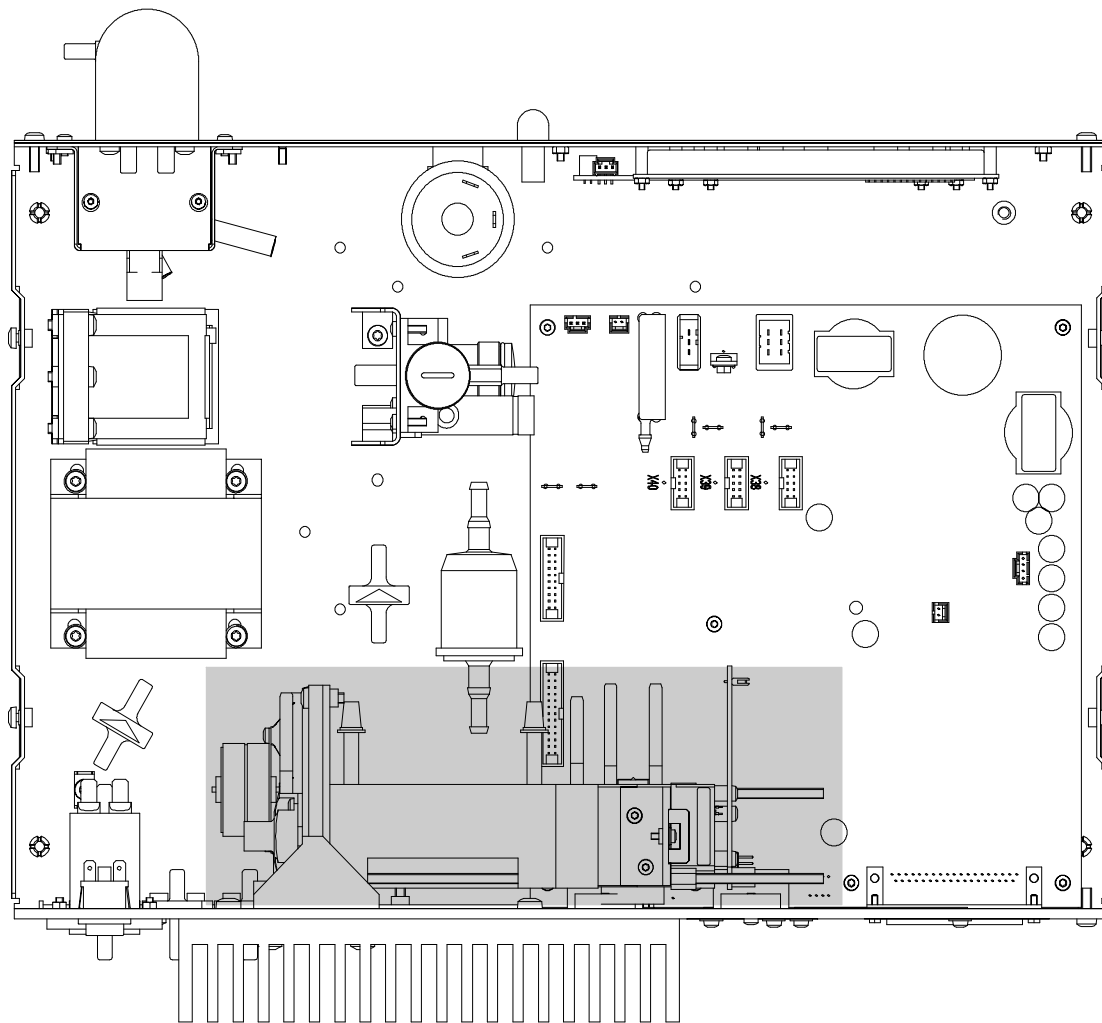

Grau: Analysierteil
Weiß: Elektronikteil

Gray: Analyzer section
White: Electronics section

Gris: Partie analyse
Blanc: Partie électronique

GASWEG/HOSING SYSTEM FOR GAS/CIRCUIT DE GAZ

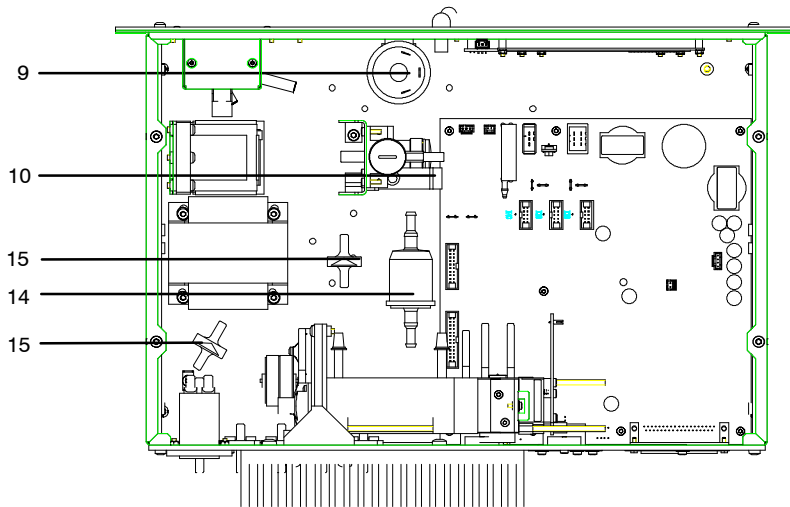

19-Zoll-Ausführung
19" rack version
Variante rack 19"

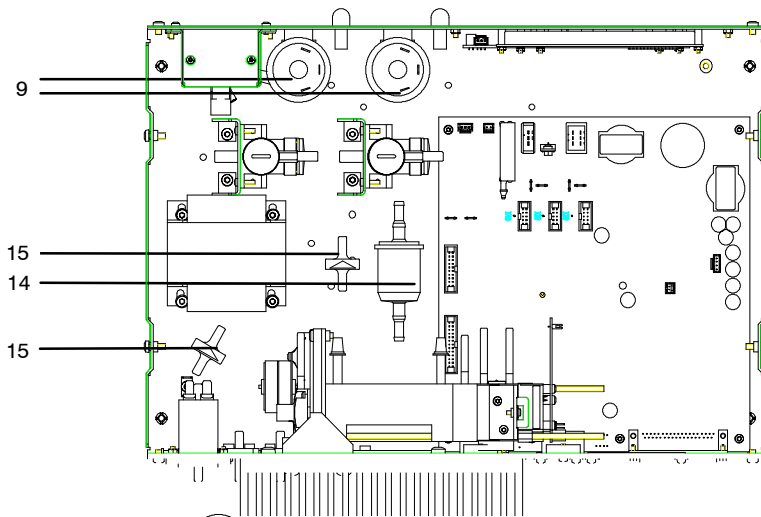

19-Zoll-Ausführung
mit getrennten Gaswegen
19" rack version
with separate gas paths
Variante rack 19" avec des
circuits de gaz séparés

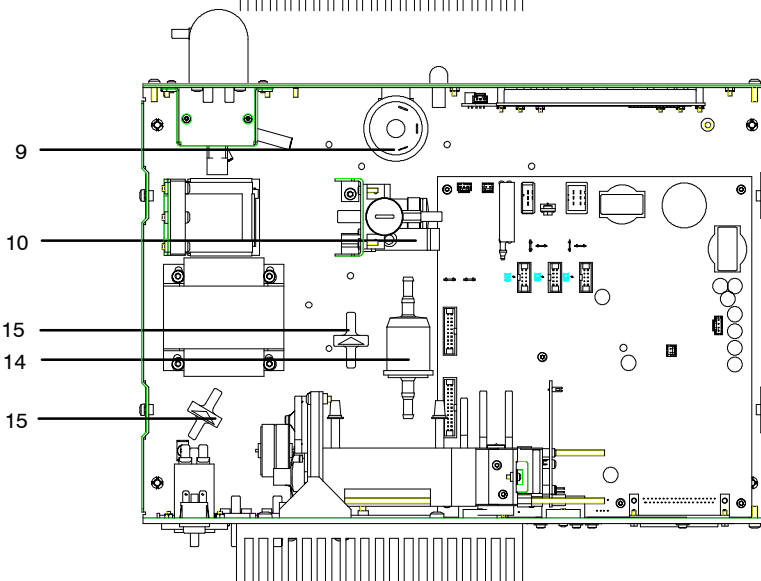

Tischausführung
Bench-top version
Variante portable

Bezeichnungen s. Seite 7-9 Designations see page 7-9 Désignations voir page 7-9

Teil-Nr. Part No. N° Pièce	Bezeichnung Designation Désignation	Bestell-Nr. Order No. N° de référence	Bemerkungen Remarks Remarques
9	Druckschalter Pressure switch Pressostat	C79302-Z1210-A2	
10	Magnetventil Solenoid valve Electrovanne	C79451-A3494-B33	
14	Sicherheitsfilter Meßgas Safety filter sample gas Filtre de sécurité pour gaz de mesure	C79127-Z400-A1	innenliegend inside à l'intérieur
15	Sicherheitsfilter Nullgas/ Chopperraumbespülung Safety filter zero gas/ chopper purge Filtre de sécurité pour gaz de zéro/ balayage de l'obturateur	A5E00059149	innenliegend inside à l'intérieur

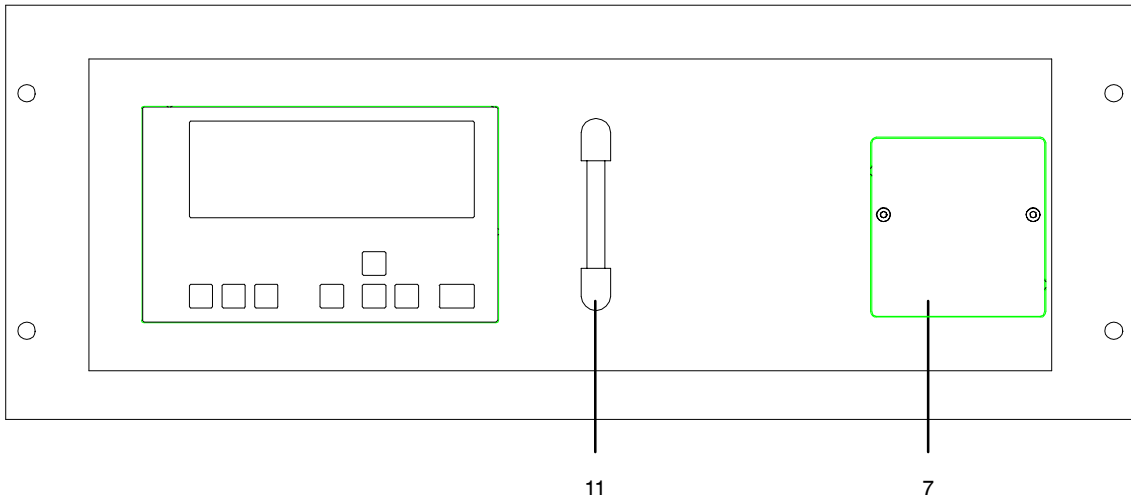

19-Zoll-Ausführung
19" rack version
Variante rack 19"

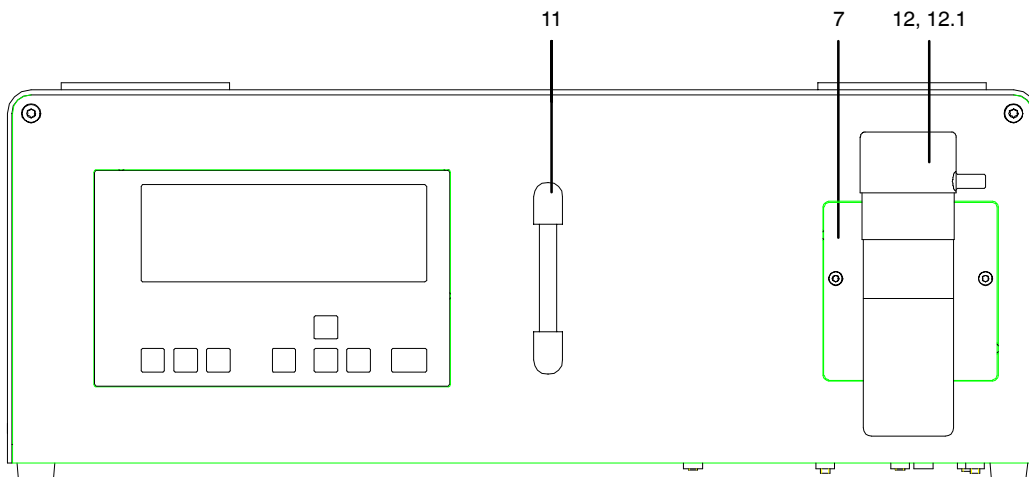

Tischausführung
Bench-top version
Variante portable

Bezeichnungen s. Seite 7-11 Designations see page 7-11 Désignations voir page 7-11

Teil-Nr. Part No. Pièce N°	Bezeichnung Designation Désignation	Bestell-Nr. Order No. N° de référence	Bemerkungen Remarks Remarques
7	Sauerstoffsensoren Oxygen sensor Capteur d'oxygène	C79451-A3458-B55	
11	Strömungsmesser Flowmeter Débitmètre	C79402-Z560-T1	
12	Kondensatbehälter Condensation trap Pot de condensation	C79451-A3008-B43	Frontseite front face avant
12.1	Filter Filter Filtre	C74127-Z1211-A1	im Kondensatbehälter in the condensation trap dans le pot de condensation

ELEKTRONIK/ELECTRONICS/ELECTRONIQUE

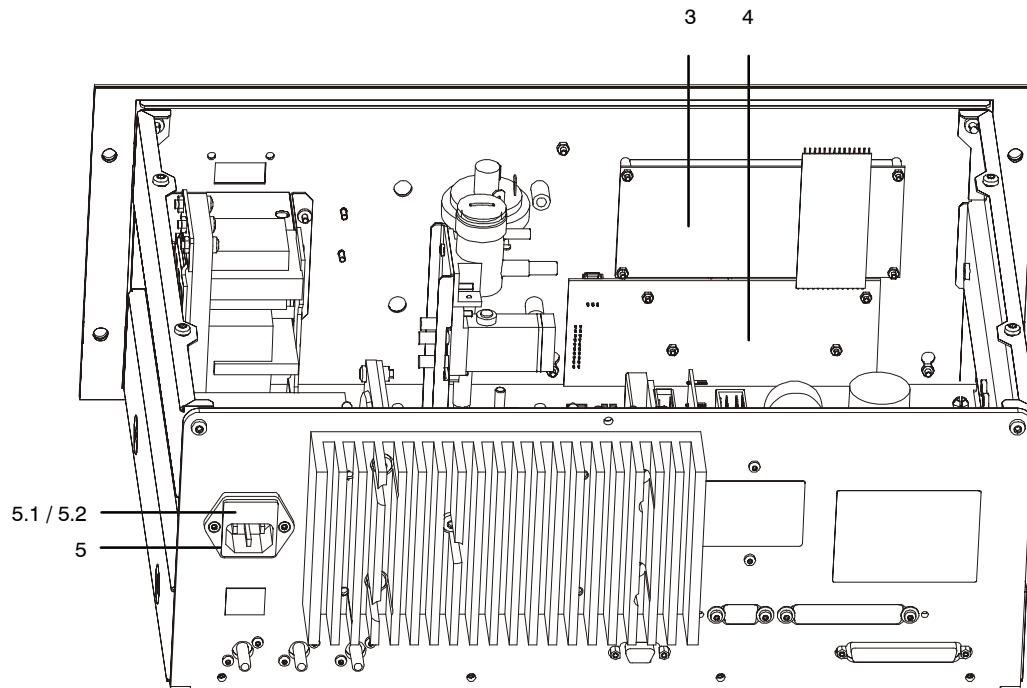

19-Zoll-Ausführung
19" rack version
Variante rack 19"

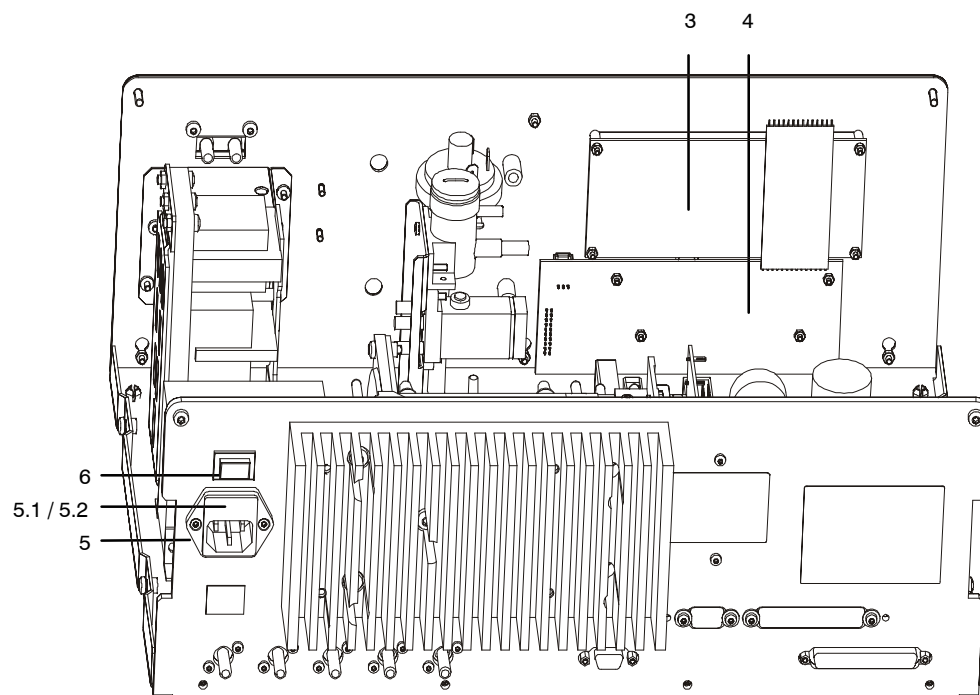

Tischausführung
Bench-top version
Variante portable
Bezeichnungen s. Seite 7-13 Designations see page 7-13 Désignations voir page 7-13

Teil-Nr. Part No. N° Pièce	Bezeichnung Designation Désignation	Bestell-Nr. Order No. N° de référence	Bemerkungen Remarks Remarques
3	LCD-Modul LCD module Module LCD	C79451-A3494-B16	
4	Tastenplatte Keyboard Panneau de touches	C79451-A3492-B605	
5	Steckerfilter Plug filter Connecteur secteur avec filtre	W75041-E5602-K2	
5.1	Schmelzeinsatz Fuse Fusible	W79054-L1010-T630	200 V/230 V; T 0,63/250 V s. Aufschrift Geräterückseite/see rear of device/voir au dos de l'appareil
5.2	Schmelzeinsatz Fuse Fusible	W79054-L1011-T125	100 V/120 V; T 1,25/250 V s. Aufschrift Geräterückseite/see rear of device/voir au dos de l'appareil
6	Netzschalter Power switch Interrupteur de mise sous tension	W75050-T1201-U101	

PUMPE/PUMP/POMPE

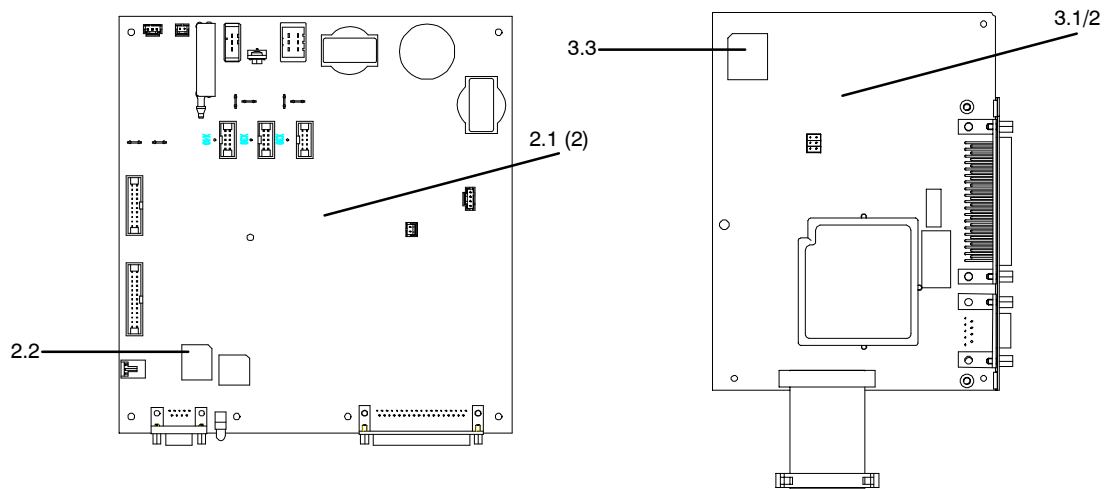
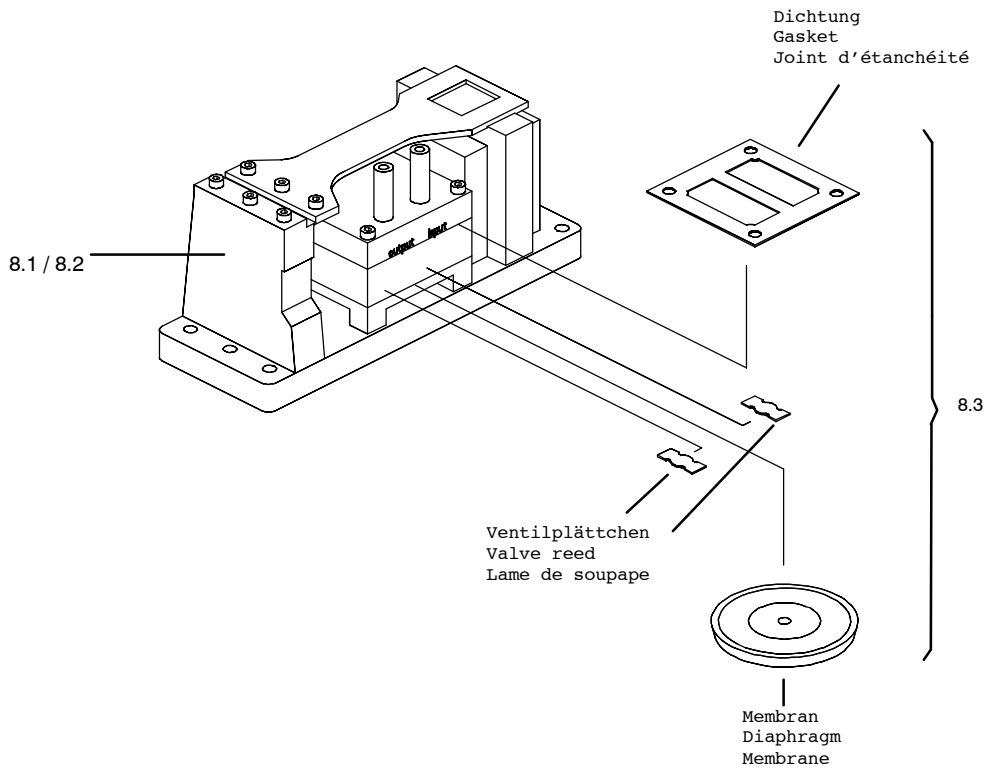

Bezeichnungen s. Seite 7-15 Designations see page 7-15 Désignations voir page 7-15

Teil-Nr. Part No. N° Pièce	Bezeichnung Designation Désignation	Bestell-Nr. Order No. N° de référence	Bemerkungen Remarks Remarques
8.1	Meßgaspumpe Sample gas pump Pompe de gaz de mesure	C79451-A3494-B10	50 Hz
8.2	Meßgaspumpe Sample gas pump Pompe de gaz de mesure	C79451-A3494-B11	60 Hz
8.3	Dichtungssatz Set of gaskets Jeu de joints d'étanchéité	C79402-Z666-E20	für Meßgaspumpe lfd. Nr. 8.1 und 8.2 for sample gas pump Nos. 8.1 and 8.2 pour pompe de gaz de mesure N° 8.1 et 8.2

Teil-Nr. Part No. N° Pièce	Bezeichnung Designation Désignation	Bestell-Nr. Order No. N° de référence	Bemerkungen Remarks Remarques
2 *)	Grundplatte Motherboard Carte mère	C79451-A3494-D501	Grundplatte und Firmware; deutsch/englisch/französisch/spanisch/ italienisch Motherboard and firmware; German/English/French/Spanish/Italian Carte mère et firmware; allemand/anglais/français/espagnol/italien
2.1 *)	Grundplatte Motherboard Carte mère	C79451-A3492-B601	Grundplatte ohne Firmware Motherboard without firmware Carte mère sans firmware
2.2	Firmware (FlashPROM)	C79451-A3494-S501	deutsch/englisch/französisch/spanisch/ italienisch German/English/French/Spanish/Italian allemand/anglais/français/espagnol/italien
3.1	Optionsbaugruppe DP Additional electronics DP Électronique additionnelle DP	A5E00057159	PROFIBUS DP
3.2	Optionsbaugruppe PA Additional electronics PA Électronique additionnelle PA	A5E00056834	PROFIBUS PA
3.3	Firmware (PROFIBUS)	A5E00057164	deutsch/englisch/französisch/spanisch/ italienisch German/English/French/Spanish/Italian allemand/anglais/français/espagnol/italien

- *) Beim Austausch ist eine neue Temperaturkompensation erforderlich.
When replacing, a new temperature compensation is required.
En cas de remplacement, une nouvelle compensation de température est nécessaire.

Analysierteil/Analyzer section/Partie analytique - Übersicht/summary/sommaire

Gas	Measuring range (v/v)		Order No. Comp	Order No. MR	IR source C79451-A3468-	Chopper C79451-A3468-	Plate w. threaded bolts and windows C79451-A3468-	Sample cell 1 length [mm] C79451-A3468-	opt.Filter	Gas filter1 C79451-A3468-	Detector 1		Sample cell 2 C79452-A3468-	Gas filter C79451-A3468-	opt.Filter C79451-A3468-	Detector 2	
	min	max									Type	Type				Type	Type
CO	50	250 vpm	A	D	B206	B515/516	B513/514	180	-	B500	2 layer HC	B525	-	-	-	-	-
CO	100	500 vpm	A	E													
CO	150	750 mg/m ³	A	U													
CO	150	750 vpm	A	F													
CO	200	1000 vpm	A	G													
CO	500	2500 vpm	A	H													
CO	50	2500 vpm	A	X													
CO	1000	5000 vpm	A	J													
CO	2000	10000 vpm	A	K													
CO	0.5	2.5 %	A	L													
CO	1	5 %	A	M													
CO	2	10 %	A	N													
CO	5	25 %	A	P													
CO	10	50 %	A	Q													
CO	20	100 %	A	R													
CO2	50	250 vpm	C	D													
CO2	200	1000 vpm	C	G													
CO2	1000	5000 vpm	C	J													
CO2	2000	10000 vpm	C	K													
CO2	0.5	2.5 %	C	L													
CO2	1	5 %	C	M													
CO2	2	10 %	C	N													
CO2	5	25 %	C	P													
CO2	10	50 %	C	Q													
CO2	20	100 %	C	R													
NO	200	1000 vpm	P	G													
NO	250	1250 mg/m ³	P	V													
NO	400	2000 mg/m ³	P	W													
NO	500	2500 vpm	P	H													
NO	1000	5000 vpm	P	J													
SO2	150	750 vpm	N	F													
SO2	400	2000 mg/m ³	N	W													
SO2	200	1000 vpm	N	G													
SO2	500	2500 vpm	N	H													
SO2	1000	5000 vpm	N	J													
SO2	2000	10000 vpm	N	K													
SO2	0.5	2.5 %	N	L													
CH4	500	2500 vpm	D	H													
CH4	0.5	2.5 %	D	L													
CH4	2	10 %	D	N													
CH4	5	25 %	D	P													
CH4	20	100 %	D	R													
F22	500	2500 vpm	U	H													
C2H4	2000	10000 vpm	F	K													
CO2/CH4	5/1	25/5 %	-	CA													
CO2/CH4	5/2	25/10 %	-	CB													
CO/CO2	10/0.5	50 %/2.5 %	-	BB													
CO/CO2	10/10	50 %/50 %	-	BA													
CO/NO	250/400	1250/2000 mg/m ³	-	AK													
CO/NO	500/500	2500/2500 vpm	-	AA													
CO/NO	2000/1000	10000/5000 vpm	-	AB													
CO/NO	1000/1000	5000/5000 vpm	-	AC													

ANALYSIERTEIL/ANALYZER SECTION/PARTIE ANALYSE

Analysierteil **7MB2335-**
Analyzer Section **7MB2335-**
Partie analyse **7MB2335-**

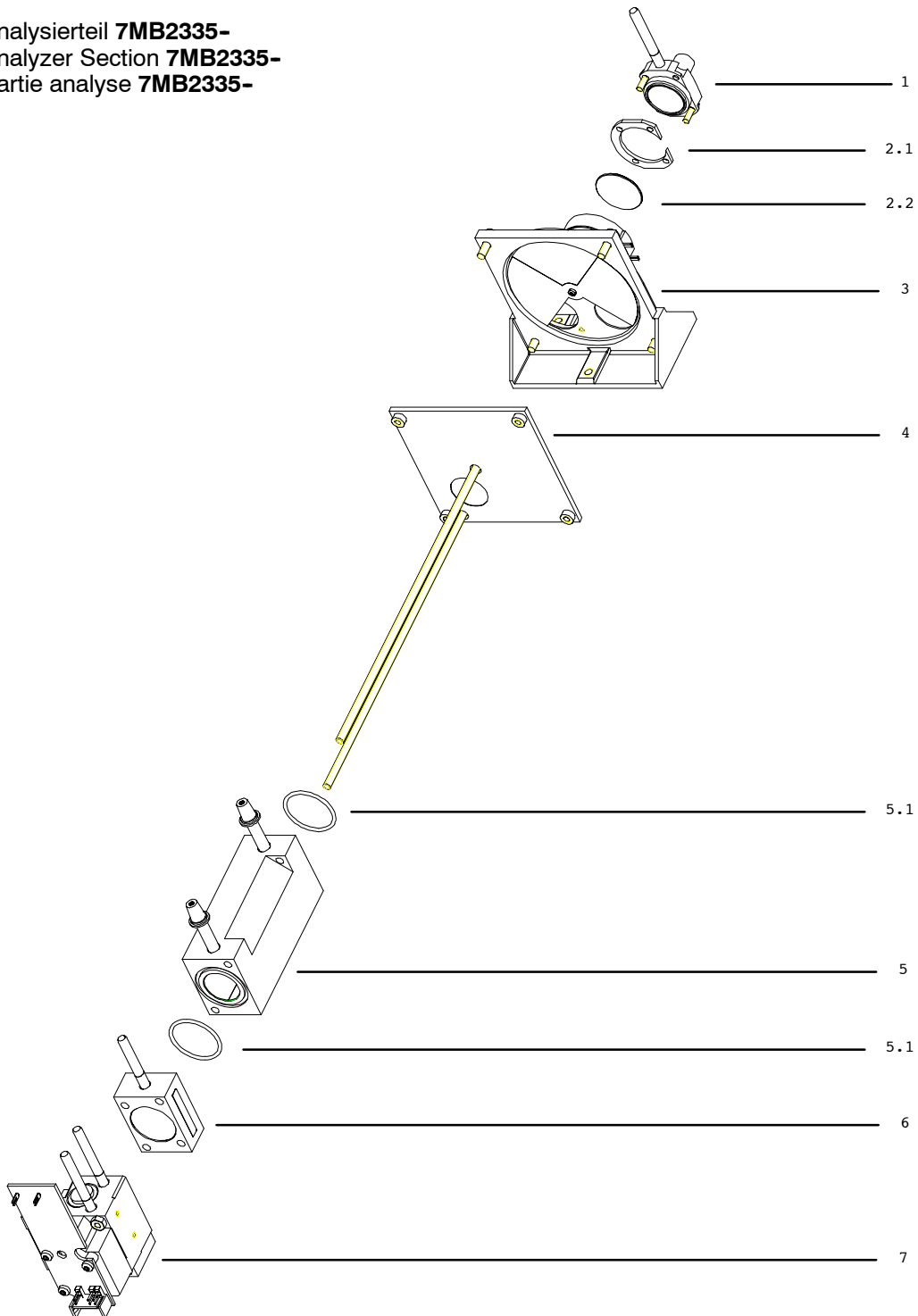

Bezeichnungen s. Seite 7-19 Designations see page 7-19 Désignations voir page 7-19

7MB2335-

Teil-Nr. Part No. N° Pièce	Bezeichnung Designation Désignation	Bestell-Nr. Order No. N° de référence	Bemerkungen Remarks Remarques
1 *)	Strahler IR source Source de rayonnement	C79451-A3468-B206	
2.1	Distanzstück Spacer Entretoise	C79451-A3468-C20	
2.2	Optisches Filter Optical filter Filtre optique	C75285-Z1491-C5	für NO **) for NO **) pour NO **)
2.2	Optisches Filter Optical filter Filtre optique	C79285-Z1302-A4	für SO ₂ **) for SO ₂ **) pour SO ₂ **)
2.2	Optisches Filter Optical filter Filtre optique	C79285-Z1491-C2	für C ₂ H ₄ for C ₂ H ₄ pour C ₂ H ₄
3 *)	Chopper Chopper Obturateur tournant	C79451-A3468-B515	
4	Platte mit Gewindebolzen und Fenster Plate with threaded bolts and windows Plaque avec tiges filetées et fenêtres	C79451-A3468-B513	
5.1	O-Ring O-ring Joint torique	C71121-Z100-A99	
5	Analysenkammer mit O-Ring Sample cell with O-ring Cellule d'analyse avec joint torique	C79451-A3468-B231	Analysenkammer 180 mm Sample cell 180 mm Cellule d'analyse 180 mm
5	Analysenkammer mit O-Ring Sample cell with O-ring Cellule d'analyse avec joint torique	C79451-A3468-B232	Analysenkammer 90 mm Sample cell 90 mm Cellule d'analyse 90 mm
5	Analysenkammer mit O-Ring Sample cell with O-ring Cellule d'analyse avec joint torique	C79451-A3468-B233	Analysenkammer 60 mm Sample cell 60 mm Cellule d'analyse 60 mm
5	Analysenkammer mit O-Ring Sample cell with O-ring Cellule d'analyse avec joint torique	C79451-A3468-B234	Analysenkammer 20 mm Sample cell 20 mm Cellule d'analyse 20 mm
5	Analysenkammer Sample cell Cellule d'analyse	C79451-A3468-B235	Analysenkammer 6 mm Sample cell 6 mm Cellule d'analyse 6 mm
5	Analysenkammer Sample cell Cellule d'analyse	C79451-A3468-B236	Analysenkammer 2 mm Sample cell 2 mm Cellule d'analyse 2 mm
6	Gasfilter Gas filter Filtre de gaz	C79451-A3458-B500	für CO for CO pour CO
6	Gasfilter Gas filter Filtre de gaz	C79451-A3458-B508	für SO ₂ for SO ₂ pour SO ₂
6	Gasfilter Gas filter Filtre de gaz	C79451-A3458-B541	für CO ₂ , kleinster MB < 5 % for CO ₂ , smallest meas. range < 5 % pour CO ₂ , étendue min. < 5 %
6	Gasfilter Gas filter Filtre de gaz	C79451-A3458-B542	für CH ₄ , kleinster MB < 2 % for CH ₄ , smallest meas. range < 2 % pour CH ₄ , étendue min. < 2 %

*) Beim Austausch ist eine neue Temperaturkompensation erforderlich.
When replacing, a new temperature compensation is required.
En cas de remplacement, une nouvelle compensation de température est nécessaire.

**) Bitte nach Austausch die Wasserdampfquerempfindlichkeiten überprüfen.
Following replacement, please check the water vapor interference.
Après le remplacement, veuillez contrôler l'influence de la vapeur d'eau.

7MB2335-

Teil-Nr. Part No. N° Pièce	Bezeichnung Designation Désignation	Bestell-Nr. Order No. N° de référence	Bemerkungen Remarks Remarques
7 *)	Empfängerkammer Detector Cellule de détection	C79451-A3468-B525	für CO, kleinster MB < 5 % for CO, smallest meas. range < 5 % pour CO, étendue min. < 5 %
7 *)	Empfängerkammer Detector Cellule de détection	C79451-A3468-B528	für CO, kleinster MB \geq 5 % for CO, smallest meas. range \geq 5 % pour CO, étendue min. \geq 5 %
7 *)	Empfängerkammer Detector Cellule de détection	C79451-A3468-B536	für CO ₂ , kleinster MB < 1000 vpm for CO ₂ , smallest meas. range < 1000 vpm pour CO ₂ , étendue min. < 1000 vpm
7 *)	Empfängerkammer Detector Cellule de détection	C79451-A3468-B526	für CO ₂ , kleinster MB \geq 1000 vpm for CO ₂ , smallest meas. range \geq 1000 vpm pour CO ₂ , étendue min. \geq 1000 vpm
7 *)	Empfängerkammer Detector Cellule de détection	C79451-A3468-B527	für CH ₄ , kleinster MB < 20 % for CH ₄ , smallest meas. range < 20 % pour CH ₄ , étendue min. < 20 %
7 *)	Empfängerkammer Detector Cellule de détection	C79451-A3468-B529	für CH ₄ , kleinster MB \geq 20 % for CH ₄ , smallest meas. range \geq 20 % pour CH ₄ , étendue min. \geq 20 %
7 *)	Empfängerkammer Detector Cellule de détection	C79451-A3468-B537	für C ₂ H ₄ for C ₂ H ₄ pour C ₂ H ₄
7 *)	Empfängerkammer Detector Cellule de détection	C79451-A3468-B520	für NO for NO pour NO
7 *)	Empfängerkammer Detector Cellule de détection	C79451-A3468-B521	für SO ₂ for SO ₂ pour SO ₂
7 *)	Empfängerkammer Detector Cellule de détection	C79451-A3468-B535	für R22 for R22 pour R22

*) Beim Austausch ist eine neue Temperaturkompensation erforderlich.

When replacing, a new temperature compensation is required.

En cas de remplacement, une nouvelle compensation de température est nécessaire.

ANALYSIERTEIL/ANALYZER SECTION/PARTIE ANALYSE

Analysierteil **7MB2337-**
 Analyzer Section **7MB2337-**
 Partie analyse **7MB2337-**

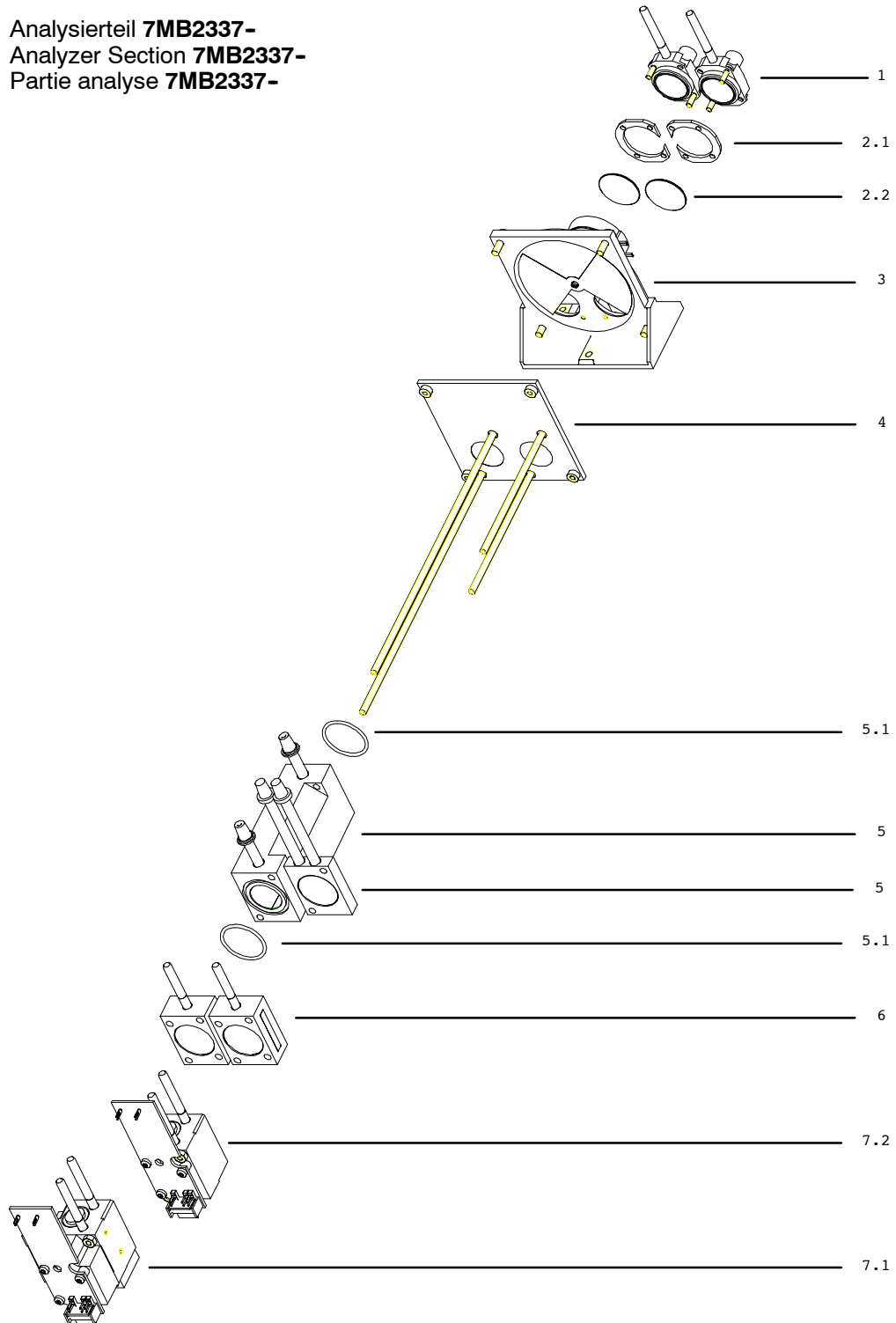

Bezeichnungen s. Seite 7-23 Designations see page 7-23 Désignations voir page 7-23

7MB2337-

Teil-Nr. Part No. N° Pièce	Bezeichnung Designation Désignation	Bestell-Nr. Order No. N° de référence	Bemerkungen Remarks Remarques
1 *)	Strahler IR source Source de rayonnement	C79451-A3468-B206	
2.1	Distanzstück Spacer Entretoise	C79451-A3468-C20	
2.2	Optisches Filter Optical filter Filtre optique	C75285-Z1491-C5	für NO **) for NO **) pour NO **)
2.2	Optisches Filter Optical filter Filtre optique	C79285-Z1302-A4	für SO ₂ **) for SO ₂ **) pour SO ₂ **)
2.2	Optisches Filter Optical filter Filtre optique	C79285-Z1491-C2	für C ₂ H ₄ for C ₂ H ₄ pour C ₂ H ₄
3 *)	Chopper Chopper Obturateur tournant	C79451-A3468-B516	
4	Platte mit Gewindebolzen und Fenstern Plate with threaded bolts and windows Plaque avec tiges filetées et fenêtres	C79451-A3468-B514	
5.1	O-Ring O-ring Joint torique	C71121-Z100-A99	
5	Analysenkammer mit O-Ring Sample cell with O-ring Cellule d'analyse avec joint torique	C79451-A3468-B231	Analysenkammer 180 mm Sample cell 180 mm Cellule d'analyse 180 mm
5	Analysenkammer mit O-Ring Sample cell with O-ring Cellule d'analyse avec joint torique	C79451-A3468-B232	Analysenkammer 90 mm Sample cell 90 mm Cellule d'analyse 90 mm
5	Analysenkammer mit O-Ring Sample cell with O-ring Cellule d'analyse avec joint torique	C79451-A3468-B233	Analysenkammer 60 mm Sample cell 60 mm Cellule d'analyse 60 mm
5	Analysenkammer mit O-Ring Sample cell with O-ring Cellule d'analyse avec joint torique	C79451-A3468-B234	Analysenkammer 20 mm Sample cell 20 mm Cellule d'analyse 20 mm
5	Analysenkammer Sample cell Cellule d'analyse	C79451-A3468-B235	Analysenkammer 6 mm Sample cell 6 mm Cellule d'analyse 6 mm
5	Analysenkammer Sample cell Cellule d'analyse	C79451-A3468-B236	Analysenkammer 2 mm Sample cell 2 mm Cellule d'analyse 2 mm
6	Gasfilter Gas filter Filtre de gaz	C79451-A3458-B500	für CO for CO pour CO
6	Gasfilter Gas filter Filtre de gaz	C79451-A3458-B508	für SO ₂ for SO ₂ pour SO ₂
6	Gasfilter Gas filter Filtre de gaz	C79451-A3468-B541	für CO ₂ , kleinster MB < 5 % for CO ₂ , smallest meas. range < 5 % pour CO ₂ , étendue min. < 5 %
6	Gasfilter Gas filter Filtre de gaz	C79451-A3468-B542	für CH ₄ , kleinster MB < 2 % for CH ₄ , smallest meas. range < 2 % pour CH ₄ , étendue min. < 2 %

*) Beim Austausch ist eine neue Temperaturkompensation erforderlich.
When replacing, a new temperature compensation is required.
En cas de remplacement, une nouvelle compensation de température est nécessaire.

**) Bitte nach Austausch die Wasserdampfquerempfindlichkeiten überprüfen.
Following replacement, please check the water vapor interference.
Après le remplacement, veuillez contrôler l'influence de la vapeur d'eau.

7MB2337-

Teil-Nr. Part No. N° Pièce	Bezeichnung Designation Désignation	Bestell-Nr. Order No. N° de référence	Bemerkungen Remarks Remarques
7.1/7.2 *)	Empfängerkammer Detector Cellule de détection	C79451-A3468-B525	für CO, kleinster MB < 5 % for CO, smallest meas. range < 5 % pour CO, étendue min. < 5 %
7.1/7.2 *)	Empfängerkammer Detector Cellule de détection	C79451-A3468-B528	für CO, kleinster MB \geq 5 % for CO, smallest meas. range \geq 5 % pour CO, étendue min. \geq 5 %
7.1/7.2 *)	Empfängerkammer Detector Cellule de détection	C79451-A3468-B536	für CO ₂ , kleinster MB < 1000 vpm for CO ₂ , smallest meas. range < 1000 vpm pour CO ₂ , étendue min. < 1000 vpm
7.1/7.2 *)	Empfängerkammer Detector Cellule de détection	C79451-A3468-B526	für CO ₂ , kleinster MB \geq 1000 vpm for CO ₂ , MBmin \geq 1000 vpm pour CO ₂ , MBmin \geq 1000 vpm
7.1/7.2 *)	Empfängerkammer Detector Cellule de détection	C79451-A3468-B527	für CH ₄ , kleinster MB < 20 % for CH ₄ , smallest meas. range < 20 % pour CH ₄ , étendue min. < 20 %
7.1/7.2 *)	Empfängerkammer Detector Cellule de détection	C79451-A3468-B529	für CH ₄ , kleinster MB \geq 20 % for CH ₄ , smallest meas. range \geq 20 % pour CH ₄ , étendue min. \geq 20 %
7.1/7.2 *)	Empfängerkammer Detector Cellule de détection	C79451-A3468-B537	für C ₂ H ₄ for C ₂ H ₄ pour C ₂ H ₄
7.1 *)	Empfängerkammer Detector Cellule de détection	C79451-A3468-B520	für NO (Kanal 1) for NO (channel 1) pour NO (canal 1)
7.2 *)	Empfängerkammer Detector Cellule de détection	C79451-A3468-B522	für NO (Kanal 2) for NO (channel 2) pour NO (canal 2)
7.1 *)	Empfängerkammer Detector Cellule de détection	C79451-A3468-B521	für SO ₂ (Kanal 1) for SO ₂ (channel 1) pour SO ₂ (canal 1)
7.2 *)	Empfängerkammer Detector Cellule de détection	C79451-A3468-B523	für SO ₂ (Kanal 2) for SO ₂ (channel 2) pour SO ₂ (canal 2)

*) Beim Austausch ist eine neue Temperaturkompensation erforderlich.

When replacing, a new temperature compensation is required.

En cas de remplacement, une nouvelle compensation de température est nécessaire.

ANALYSIERTEIL 1/ANALYZER SECTION 1/PARTIE ANALYSE 1 CO/NO

Analysierteil **7MB2338-.AA..-, -.AK..-**
 Teil 1: Konfiguration für CO/NO

Analyzer Section **7MB2338-.AA..-, -.AK..-**
 part 1: configuration for CO/NO

Partie analyse **7MB2338-.AA..-, -.AK..-**
 partie 1: configuration pour CO/NO

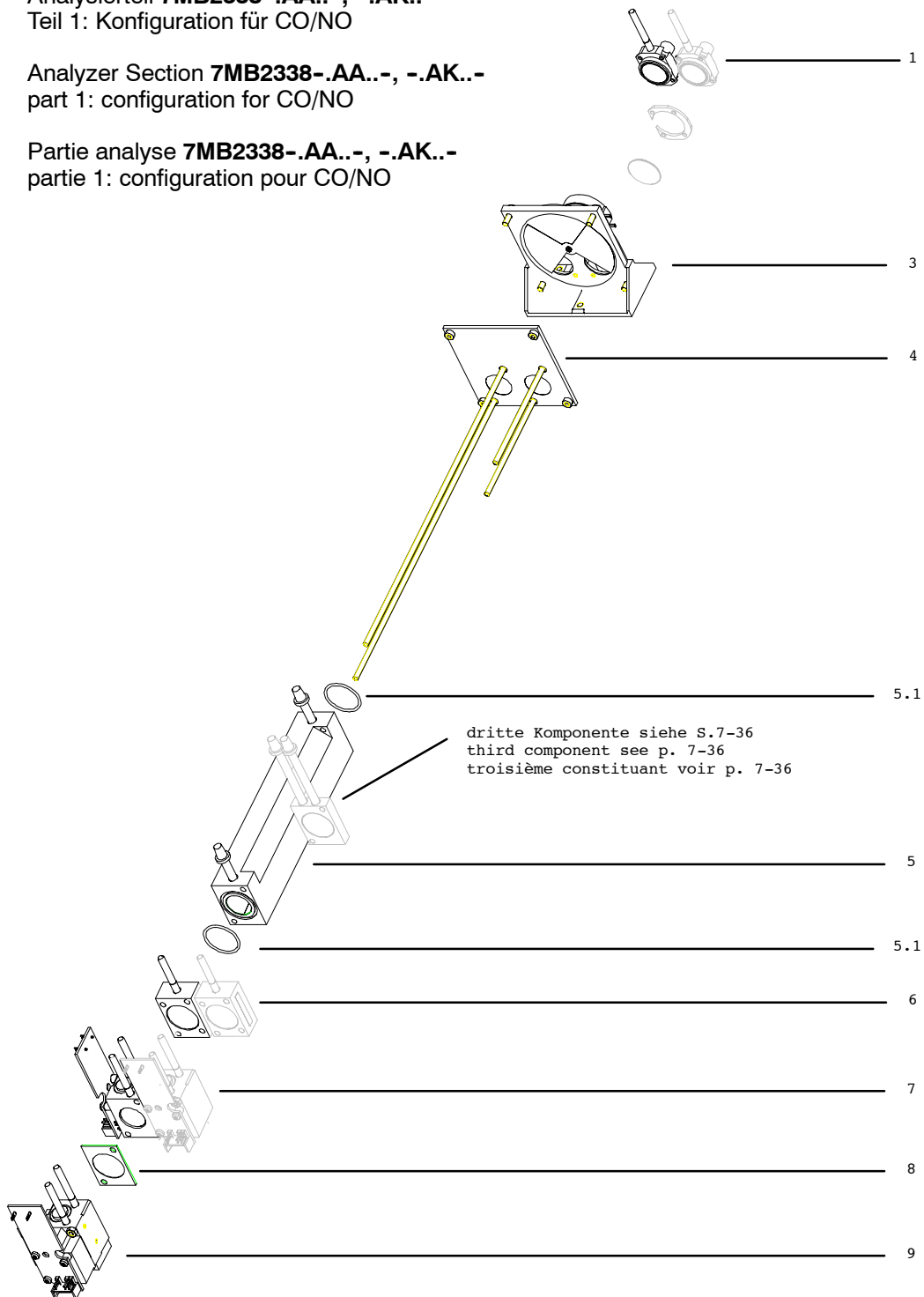

Bezeichnungen s. Seite 7-27 Designations see page 7-27 Désignations voir page 7-27

7MB2338-.AA.-, -.AK.-

Teil-Nr. Part No. N° Pièce	Bezeichnung Designation Désignation	Bestell-Nr. Order No. N° de référence	Bemerkungen Remarks Remarques
1 *)	Strahler IR source Source de rayonnement	C79451-A3468-B206	
3 *)	Chopper Chopper Obturateur tournant	C79451-A3468-B516	
4	Platte mit Gewindebolzen und Fenstern Plate with threaded bolts and windows Plaque avec tiges filetées et fenêtres	C79451-A3468-B514	
5.1	O-Ring O-ring Joint torique	C71121-Z100-A99	
5	Analysenkammer mit O-Ring Sample cell with O-ring Cellule d'analyse avec joint torique	C79451-A3468-B231	Analysenkammer 180 mm Sample cell 180 mm Cellule d'analyse 180 mm
6	Gasfilter Gas filter Filtre de gaz	C79451-A3458-B500	für CO for CO pour CO
7 *)	Empfängerkammer Detector Cellule de détection	C79451-A3468-B530	für CO for CO pour CO
8	Optisches Filter Optical filter Filtre optique	C79451-A3458-B103	für NO **) for NO **) pour NO **)
9 *)	Empfängerkammer Detector Cellule de détection	C79451-A3468-B520	für NO (Kanal 1) for NO (channel 1) pour NO (canal 1)

*) Beim Austausch ist eine neue Temperaturkompensation erforderlich.
When replacing, a new temperature compensation is required.
En cas de remplacement, une nouvelle compensation de température est nécessaire.

**) Bitte nach Austausch die Wasserdampfquerempfindlichkeiten überprüfen.
Following replacement, please check the water vapor interference.
Après le remplacement, veuillez contrôler l'influence de la vapeur d'eau.

ANALYSIERTEIL 1/ANALYZER SECTION 1/PARTIE ANALYSE 1 CO/NO

Analysierteil **7MB2338-.AB..-**
Teil 1: Konfiguration für CO/NO

Analyzer Section **7MB2338-.AB..-**
part 1: configuration for CO/NO

Partie analyse **7MB2338-.AB..-**
partie 1: configuration pour CO/NO

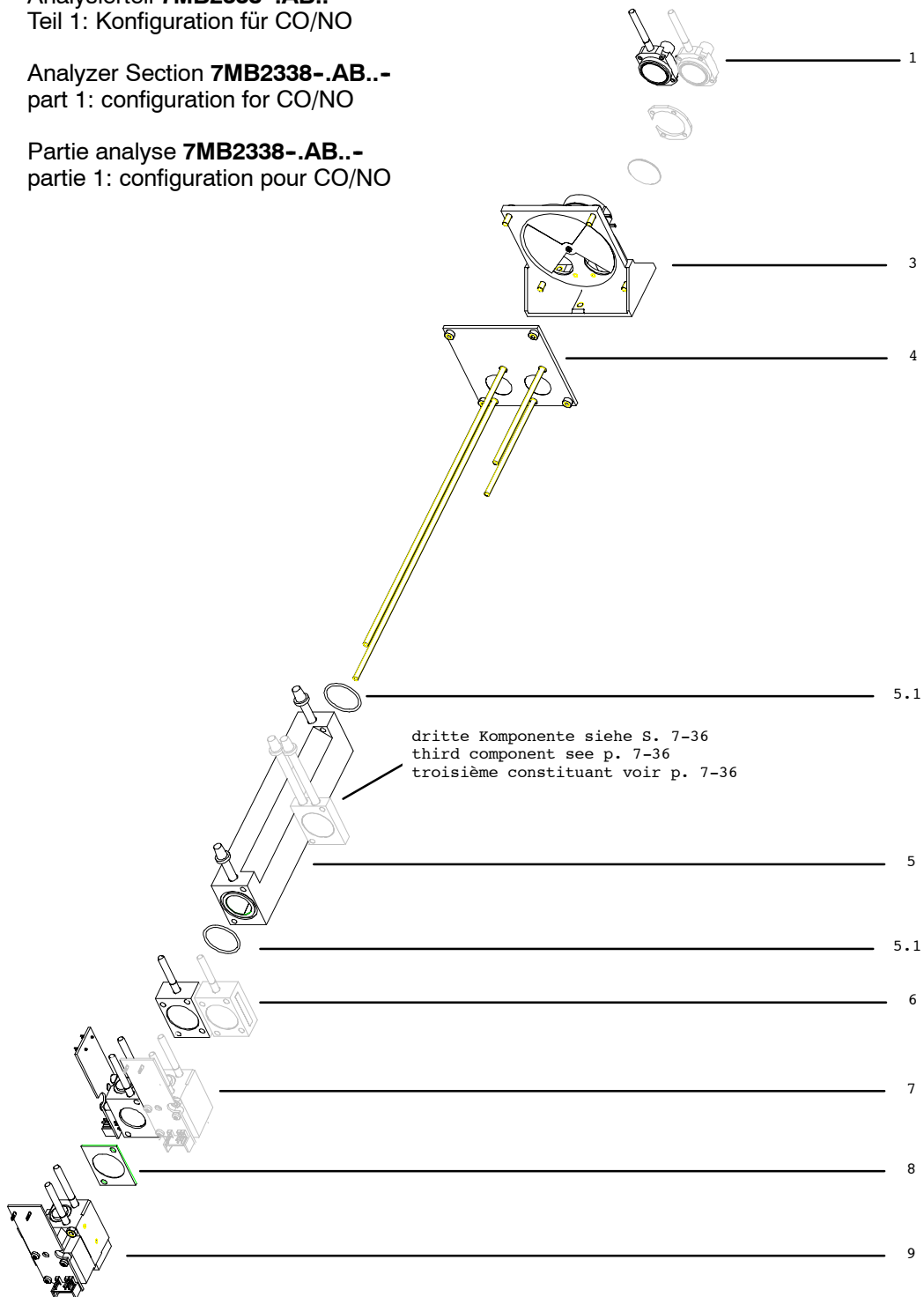

Bezeichnungen s. Seite 7-29 Designations see page 7-29 Désignations voir page 7-29

7MB2338-.AB..-

Teil-Nr. Part No. N° Pièce	Bezeichnung Designation Désignation	Bestell-Nr. Order No. N° de référence	Bemerkungen Remarks Remarques
1 *)	Strahler IR source Source de rayonnement	C79451-A3468-B206	
3 *)	Chopper Chopper Obturbateur tournant	C79451-A3468-B516	
4	Platte mit Gewindebolzen und Fenstern Plate with threaded bolts and windows Plaque avec tiges filetées et fenêtres	C79451-A3468-B514	
5.1	O-Ring O-ring Joint torique	C71121-Z100-A99	
5	Analysenkammer mit O-Ring Sample cell with O-ring Cellule d'analyse avec joint torique	C79451-A3468-B233	Analysenkammer 60 mm Sample cell 60 mm Cellule d'analyse 60 mm
6	Gasfilter Gas filter Filtre de gaz	C79451-A3458-B500	für CO for CO pour CO
7 *)	Empfängerkammer Detector Cellule de détection	C79451-A3468-B530	für CO for CO pour CO
8	Optisches Filter Optical filter Filtre optique	C79451-A3458-B103	für NO **) for NO **) pour NO **)
9 *)	Empfängerkammer Detector Cellule de détection	C79451-A3468-B520	für NO (Kanal 1) for NO (channel 1) pour NO (canal 1)

*) Beim Austausch ist eine neue Temperaturkompensation erforderlich.
When replacing, a new temperature compensation is required.
En cas de remplacement, une nouvelle compensation de température est nécessaire.

**) Bitte nach Austausch die Wasserdampfquerempfindlichkeiten überprüfen.
Following replacement, please check the water vapor interference.
Après le remplacement, veuillez contrôler l'influence de la vapeur d'eau.

ANALYSIERTEIL 1/ANALYZER SECTION 1/PARTIE ANALYSE 1 CO/NO

Analysierteil **7MB2338-.AC..-**
Teil 1: Konfiguration für CO/NO

Analyzer Section **7MB2338-.AC..-**
part 1: configuration for CO/NO

Partie analyse **7MB2338-.AC..-**
partie 1: configuration pour CO/NO

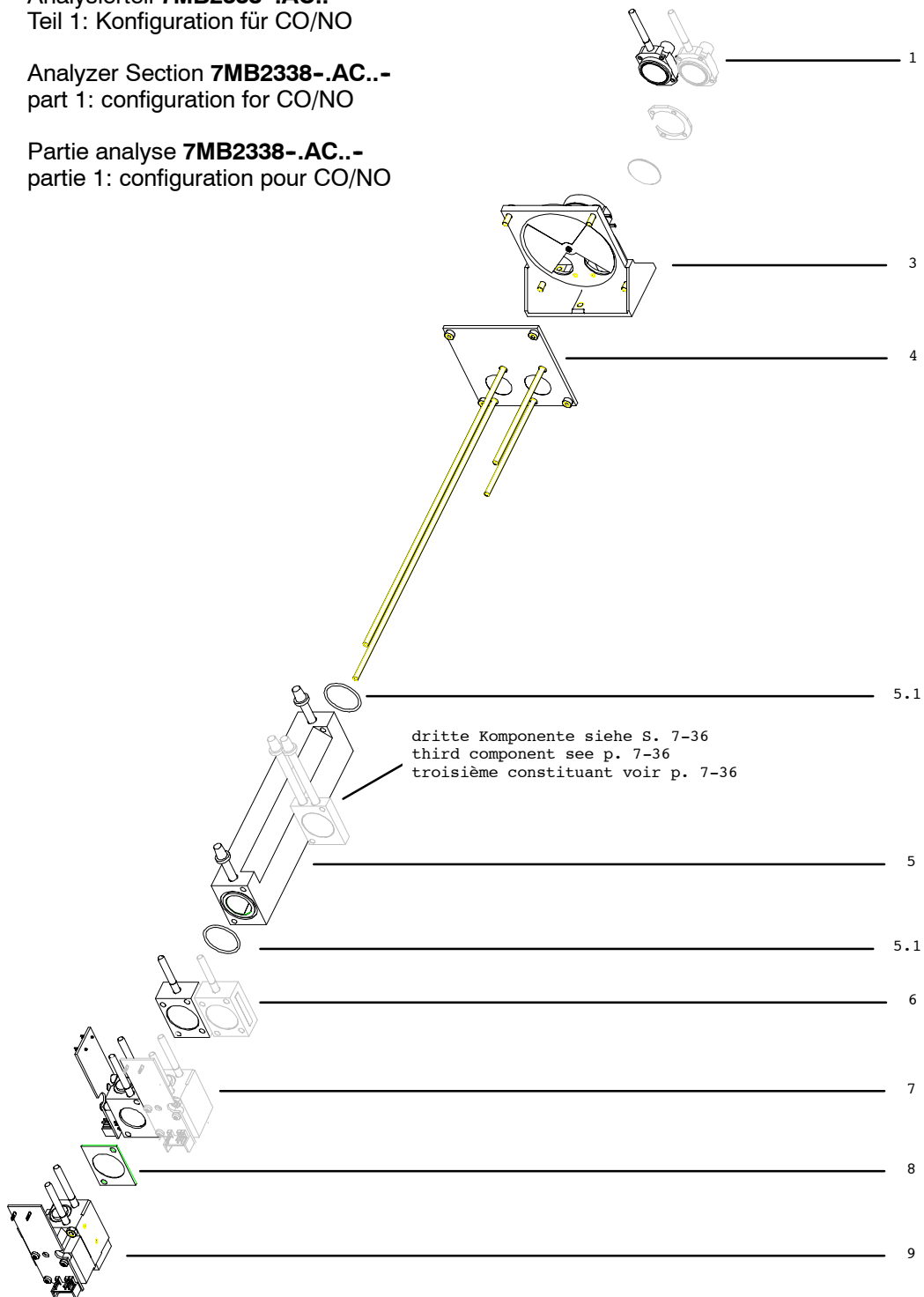

Bezeichnungen s. Seite 7-31 Designations see page 7-31 Désignations voir page 7-31

7MB2338-.AC..-

Teil-Nr. Part No. N° Pièce	Bezeichnung Designation Désignation	Bestell-Nr. Order No. N° de référence	Bemerkungen Remarks Remarques
1 *)	Strahler IR source Source de rayonnement	C79451-A3468-B206	
3 *)	Chopper Chopper Obturateur tournant	C79451-A3468-B516	
4	Platte mit Gewindebolzen und Fenstern Plate with threaded bolts and windows Plaque avec tiges filetées et fenêtres	C79451-A3468-B514	
5.1	O-Ring O-ring Joint torique	C71121-Z100-A99	
5	Analysenkammer mit O-Ring Sample cell with O-ring Cellule d'analyse avec joint torique	C79451-A3468-B232	Analysenkammer 90 mm Sample cell 90 mm Cellule d'analyse 90 mm
6	Gasfilter Gas filter Filtre de gaz	C79451-A3458-B500	für CO for CO pour CO
7 *)	Empfängerkammer Detector Cellule de détection	C79451-A3468-B530	für CO for CO pour CO
8	Optisches Filter Optical filter Filtre optique	C79451-A3458-B103	für NO **) for NO **) pour NO **)
9 *)	Empfängerkammer Detector Cellule de détection	C79451-A3468-B520	für NO (Kanal 1) for NO (channel 1) pour NO (canal 1)

*) Beim Austausch ist eine neue Temperaturkompensation erforderlich.
When replacing, a new temperature compensation is required.
En cas de remplacement, une nouvelle compensation de température est nécessaire.

**) Bitte nach Austausch die Wasserdampfquerempfindlichkeiten überprüfen.
Following replacement, please check the water vapor interference.
Après le remplacement, veuillez contrôler l'influence de la vapeur d'eau.

ANALYSIERTEIL 1/ANALYZER SECTION 1/PARTIE ANALYSE 1 CO/CO₂ + CO₂/CH₄

Analysierteil **7MB2338-.BA.., -.CB..-**
Teil 1: Konfiguration für CO/CO₂, CO₂/CH₄

Analyzer Section **7MB2338-.BA.., -.CB..-**
part 1: configuration for CO/CO₂, CO₂/CH₄

Partie analyse **7MB2338-.BA.., -.CB..-**
partie 1: configuration pour CO/CO₂, CO₂/CH₄

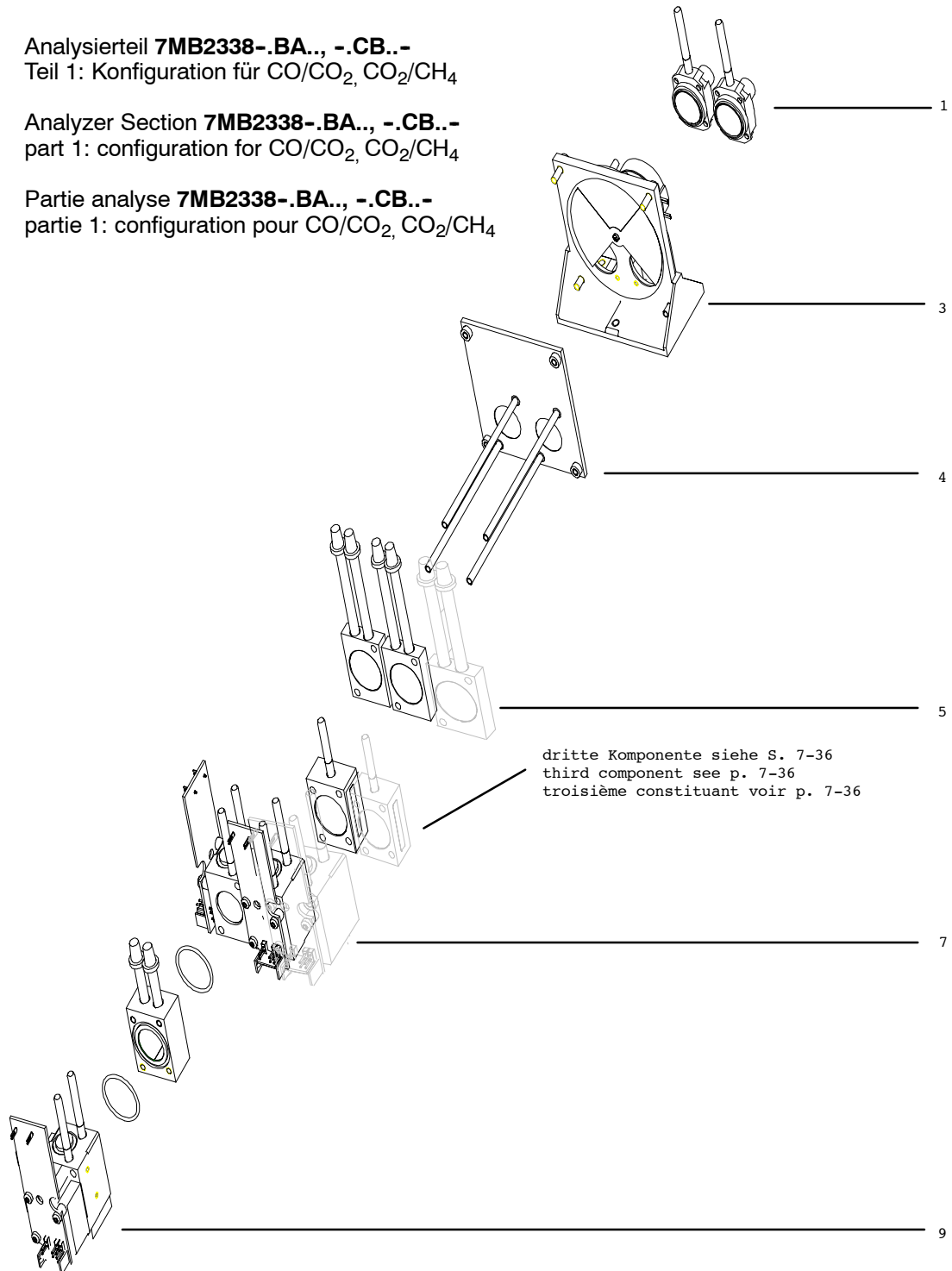

Bezeichnungen s. Seite 7-33 Designations see page 7-33 Désignations voir page 7-33

7MB2338-

Teil-Nr. Part No. N° Pièce	Bezeichnung Designation Désignation	Bestell-Nr. Order No. N° de référence	Bemerkungen Remarks Remarques
1 *)	Strahler IR source Source de rayonnement	C79451-A3468-B206	
3 *)	Chopper Chopper Obturbateur tournant	C79451-A3468-B516	
4	Platte mit Gewindebolzen und Fenstern Plate with threaded bolts and windows Plaque avec tiges filetées et fenêtres	C79451-A3468-B514	

7MB2338-.BA..-

5	Analysenkammer Sample cell Cellule d'analyse	C79451-A3468-B236	Analysenkammer 2 mm Sample cell 2 mm Cellule d'analyse 2 mm
7 *)	Empfängerammer Detector Cellule de détection	C79451-A3468-B532	für CO for CO pour CO
9 *)	Empfängerammer Detector Cellule de détection	C79451-A3468-B526	für CO ₂ for CO ₂ pour CO ₂

7MB2338-.CB..-

5	Analysenkammer Sample cell Cellule d'analyse	C79451-A3468-B235	Analysenkammer 6 mm Sample cell 6 mm Cellule d'analyse 6 mm
7 *)	Empfängerammer Detector Cellule de détection	C79451-A3468-B531	für CO ₂ for CO ₂ pour CO ₂
9 *)	Empfängerammer Detector Cellule de détection	C79451-A3468-B527	für CH ₄ for CH ₄ pour CH ₄

*) Beim Austausch ist eine neue Temperaturkompensation erforderlich.

When replacing, a new temperature compensation is required.

En cas de remplacement, une nouvelle compensation de température est nécessaire.

ANALYSIERTEIL 1/ANALYZER SECTION 1/PARTIE ANALYSE 1 CO/CO₂ + CO₂/CH₄

Analysierteil **7MB2338-.BB.-, -.CA.-**
 Teil 1: Konfiguration für CO/CO₂, CO₂/CH₄



Analyser Section **7MB2338-.BB.-, -.CA.-**
 part 1: configuration for CO/CO₂, CO₂/CH₄

Partie analyse **7MB2338-.BB.-, -.CA.-**
 partie 1: configuration pour CO/CO₂, CO₂/CH₄

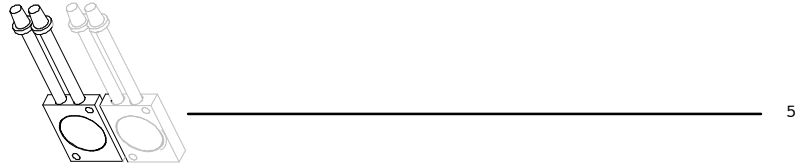
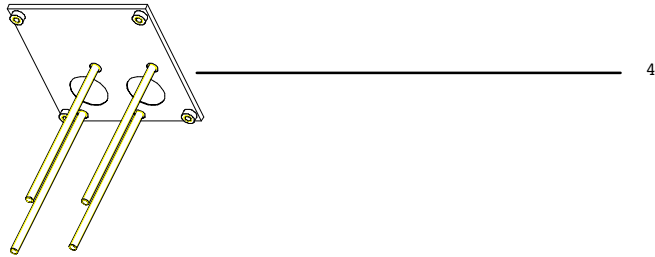
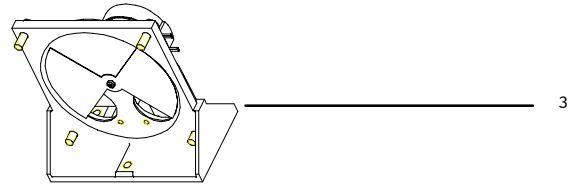

dritte Komponente siehe S. 7-36
 third component see p. 7-36
 troisième constituant voir p. 7-36

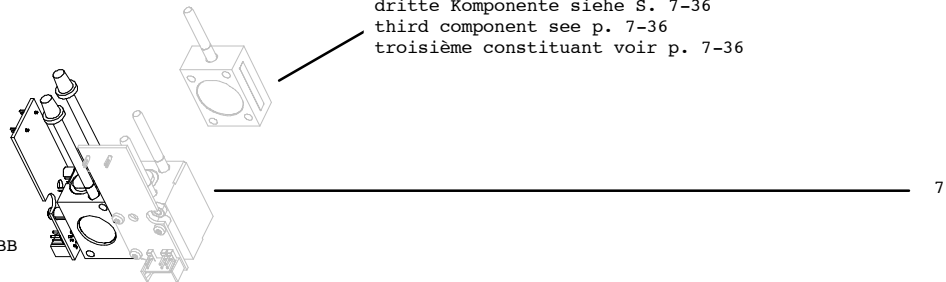

nur 7MB2338-BB
 only 7MB2338-BB
 seulement 7MB2338-BB

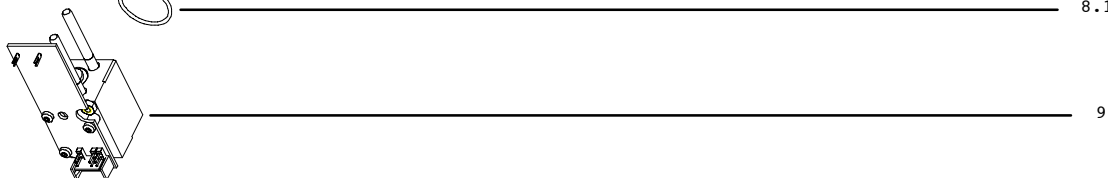
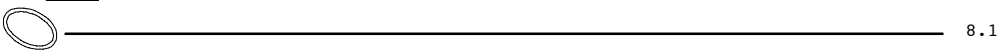
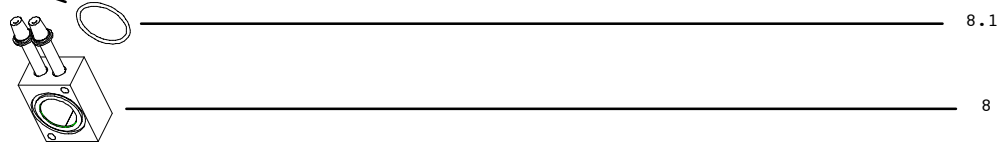

Bezeichnungen s. Seite 7-35 Designations see page 7-35 Désignations voir page 7-35

7MB2338-

Teil-Nr. Part No. N° Pièce	Bezeichnung Designation Désignation	Bestell-Nr. Order No. N° de référence	Bemerkungen Remarks Remarques
1 *)	Strahler IR source Source de rayonnement	C79451-A3468-B206	
3 *)	Chopper Chopper Obturbateur tournant	C79451-A3468-B516	
4	Platte mit Gewindebolzen und Fenstern Plate with threaded bolts and windows Plaque avec tiges filetées et fenêtres	C79451-A3468-B514	

7MB2338-.BB..-

5	Analysenkammer Sample cell Cellule d'analyse	C79451-A3468-B236	Analysenkammer 2 mm Sample cell 2 mm Cellule d'analyse 2 mm
7 *)	Empfängerammer Detector Cellule de détection	C79451-A3468-B532	für CO for CO pour CO
8.1	O-Ring O-ring Joint torique	C71121-Z100-A99	
8	Analysenkammer mit O-Ring Sample cell with O-ring Cellule d'analyse avec joint torique	C79451-A3468-B234	Analysenkammer 20 mm Sample cell 20 mm Cellule d'analyse 20 mm
9 *)	Empfängerammer Detector Cellule de détection	C79451-A3468-B526	für CO ₂ for CO ₂ pour CO ₂

7MB2338-.CA..-

5	Analysenkammer Sample cell Cellule d'analyse	C79451-A3468-B235	Analysenkammer 6 mm Sample cell 6 mm Cellule d'analyse 6 mm
7 *)	Empfängerammer Detector Cellule de détection	C79451-A3468-B531	für CO ₂ for CO ₂ pour CO ₂
8	Analysenkammer Sample cell Cellule d'analyse	C79451-A3468-B235	Analysenkammer 6 mm Sample cell 6 mm Cellule d'analyse 6 mm
9 *)	Empfängerammer Detector Cellule de détection	C79451-A3468-B527	für CH ₄ for CH ₄ pour CH ₄

- *) Beim Austausch ist eine neue Temperaturkompensation erforderlich.
When replacing, a new temperature compensation is required.
En cas de remplacement, une nouvelle compensation de température est nécessaire.

ANALYSIERTEIL 2/ANALYZER SECTION 2/PARTIE ANALYSE 2

Analysierteile **7MB2338-....0-□□.**
 Teil 2: dritte Komponente

Analyzer Sections **7MB2338-....0-□□.**
 part 2: third component

Parties analyse **7MB2338-....0-□□.**
 partie 2: troisième constituant
 Graue Bauteile: Teil 1 (Beispiel)
 Gray parts: part 1 (example)
 Pièces grises: partie 1 (exemple)

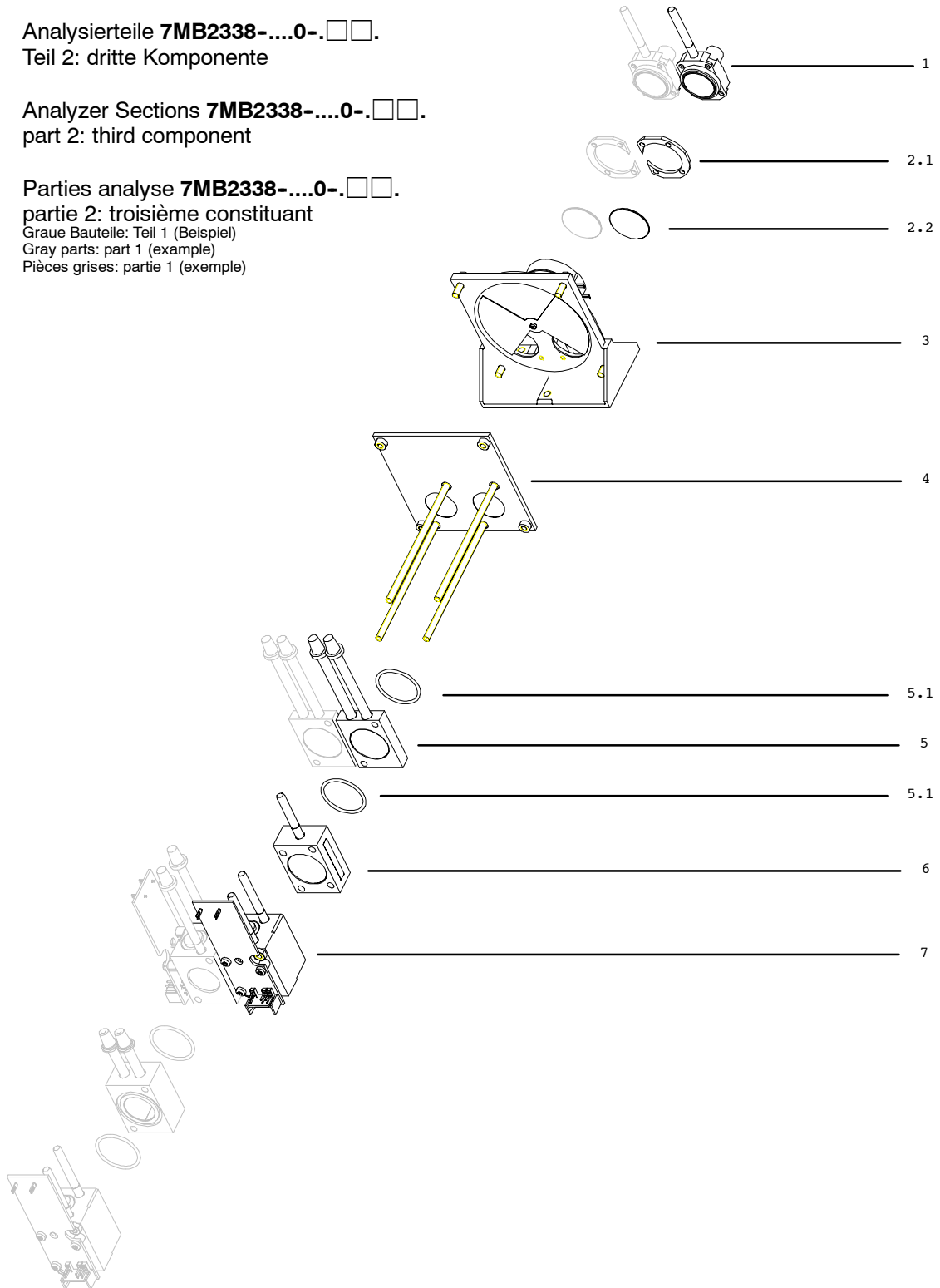

Bezeichnungen s. Seite 7-37 Designations see page 7-37 Désignations voir page 7-37

7MB2338-...0-□□.

Teil-Nr. Part No. N° Pièce	Bezeichnung Designation Désignation	Bestell-Nr. Order No. N° de référence	Bemerkungen Remarks Remarques
1 *)	Strahler IR source Source de rayonnement	C79451-A3468-B206	
2.1	Distanzstück Spacer Entretoise	C79451-A3468-C20	
2.2	Optisches Filter Optical filter Filtre optique	C75285-Z1491-C5	für NO **) for NO **) pour NO **)
2.2	Optisches Filter Optical filter Filtre optique	C79285-Z1302-A4	für SO ₂ **) for SO ₂ **) pour SO ₂ **)
2.2	Optisches Filter Optical filter Filtre optique	C79285-Z1491-C2	für C ₂ H ₄ for C ₂ H ₄ pour C ₂ H ₄
3 *)	Chopper Chopper Obturateur tournant	C79451-A3468-B516	
4	Platte mit Gewindebolzen und Fenstern Plate with threaded bolts and windows Plaque avec tiges filetées et fenêtres	C79451-A3468-B514	
5.1	O-Ring O-ring Joint torique	C71121-Z100-A99	
5	Analysenkammer mit O-Ring Sample cell with O-ring Cellule d'analyse avec joint torique	C79451-A3468-B231	Analysenkammer 180 mm Sample cell 180 mm Cellule d'analyse 180 mm
5	Analysenkammer mit O-Ring Sample cell with O-ring Cellule d'analyse avec joint torique	C79451-A3468-B232	Analysenkammer 90 mm Sample cell 90 mm Cellule d'analyse 90 mm
5	Analysenkammer mit O-Ring Sample cell with O-ring Cellule d'analyse avec joint torique	C79451-A3468-B233	Analysenkammer 60 mm Sample cell 60 mm Cellule d'analyse 60 mm
5	Analysenkammer mit O-Ring Sample cell with O-ring Cellule d'analyse avec joint torique	C79451-A3468-B234	Analysenkammer 20 mm Sample cell 20 mm Cellule d'analyse 20 mm
5	Analysenkammer Sample cell Cellule d'analyse	C79451-A3468-B235	Analysenkammer 6 mm Sample cell 6 mm Cellule d'analyse 6 mm
5	Analysenkammer Sample cell Cellule d'analyse	C79451-A3468-B236	Analysenkammer 2 mm Sample cell 2 mm Cellule d'analyse 2 mm
6	Gasfilter Gas filter Filtre de gaz	C79451-A3458-B500	für CO for CO pour CO
6	Gasfilter Gas filter Filtre de gaz	C79451-A3458-B508	für SO ₂ for SO ₂ pour SO ₂
6	Gasfilter Gas filter Filtre de gaz	C79451-A3468-B541	für CO ₂ , kleinster MB < 5 % for CO ₂ , smallest meas. range < 5 % pour CO ₂ , étendue min. < 5 %
6	Gasfilter Gas filter Filtre de gaz	C79451-A3468-B542	für CH ₄ , kleinster MB < 2 % for CH ₄ , smallest meas. range < 2 % pour CH ₄ , étendue min. < 2 %

*) Beim Austausch ist eine neue Temperaturkompensation erforderlich.

When replacing, a new temperature compensation is required.

En cas de remplacement, une nouvelle compensation de température est nécessaire.

**) Bitte nach Austausch die Wasserdampfquerempfindlichkeiten überprüfen.

Following replacement, please check the water vapor interference.

Après le remplacement, veuillez contrôler l'influence de la vapeur d'eau.

7MB2338-....0-□□.

Teil-Nr. Part No. N° Pièce	Bezeichnung Designation Désignation	Bestell-Nr. Order No. N° de référence	Bemerkungen Remarks Remarques
7 *)	Empfängerammer Detector Cellule de détection	C79451-A3468-B525	für CO, kleinster MB < 5 % for CO, smallest meas. range < 5 % pour CO, étendue min. < 5 %
7 *)	Empfängerammer Detector Cellule de détection	C79451-A3468-B528	für CO, kleinster MB ≥ 5 % for CO, smallest meas. range ≥ 5 % pour CO, étendue min. ≥ 5 %
7 *)	Empfängerammer Detector Cellule de détection	C79451-A3468-B536	für CO ₂ , kleinster MB < 1000 vpm for CO ₂ , smallest meas. range < 1000 vpm pour CO ₂ , étendue min. < 1000 vpm
7 *)	Empfängerammer Detector Cellule de détection	C79451-A3468-B526	für CO ₂ , kleinster MB ≥ 1000 vpm for CO ₂ , smallest meas. range ≥ 1000 vpm pour CO ₂ , étendue min. ≥ 1000 vpm
7 *)	Empfängerammer Detector Cellule de détection	C79451-A3468-B527	für CH ₄ , kleinster MB < 20 % for CH ₄ , smallest meas. range < 20 % pour CH ₄ , étendue min. < 20 %
7 *)	Empfängerammer Detector Cellule de détection	C79451-A3468-B529	für CH ₄ , kleinster MB ≥ 20 % for CH ₄ , smallest meas. range ≥ 20 % pour CH ₄ , étendue min. ≥ 20 %
7 *)	Empfängerammer Detector Cellule de détection	C79451-A3468-B537	für C ₂ H ₄ for C ₂ H ₄ pour C ₂ H ₄
7 *)	Empfängerammer Detector Cellule de détection	C79451-A3468-B522	für NO (Kanal 1) for NO (channel 1) pour NO (canal 1)
7 *)	Empfängerammer Detector Cellule de détection	C79451-A3468-B523	für SO ₂ (Kanal 2) for SO ₂ (channel 2) pour SO ₂ (canal 2)

*) Beim Austausch ist eine neue Temperaturkompensation erforderlich.

When replacing, a new temperature compensation is required.

En cas de remplacement, une nouvelle compensation de température est nécessaire.

Appendix

8

8.1	Returned Deliveries	8-2
8.2	Explanations	8-4
8.2.1	Abbreviations	8-4
8.2.2	Explanation of Symbols	8-4
8.3	Software Release Versions	8-5

8.1 Returned Deliveries

The gas analyzer or spare parts should be returned in the original packing material. If the original packing material is no longer available, wrap the analyzer in plastic foil and pack in a sufficiently large box lined with padding material (wood shavings or similar). When using wood shavings, the stuffing should be at least 15 cm thick on all sides.

When shipping overseas, the analyzers must be additionally sealed air-tight in a 0.2 mm thick polyethylene foil with the addition of a drying agent (e.g. silica gel). In addition, the transport container should be lined internally with a layer of union paper.

Please photocopy the form printed overleaf, fill in, and enclose with the returned device.

In the case of a guarantee claim, please enclose your guarantee card.

8.1.1 Addresses for Returned Deliveries

Technical support - For technical support, please contact our service helpline:
Tel.: + 33 3 88 90 66 77
Fax: + 33 3 88 90 66 88

Spare parts service Please send your orders for spare parts to the following address:
- SIEMENS CSC (Centre Service Client)
Tel.: + 33 3 88 90 66 77
Fax: + 33 3 88 90 66 88
1, chemin de la Sandlach
F-67506 Haguenau

Repairs To enable fast detection and elimination of faults, please return the analyzers to the following address:
- SIEMENS CSC (Centre Service Client)
Hr. Criquy
Tel.: +33 3 88 90 55 35
Fax: +33 3 88 90 66 88
1, chemin de la Sandlach
F-67506 Haguenau

Returned deliveries form

 Repair

 Guarantee

Name of customer	
Address	
Person responsible	
Delivery address	
Telephone Fax e-Mail	
Address for returned delivery (if different from above)	
Customer (original) Order No.	
Siemens (original) Order confirmation No.	
Device name	
MLFB No.	
Serial No.	
Designation of returned part	
Fault description	
Process data at point of measurement	
Operating temperature	
Operating pressure	
Composition of sample gas	
Duration of use/ date put into service	

Repair report	
RH No.:	Incoming date: Outgoing date: Technician:

Do not fill in this block; for internal use

8.2 Explanations

8.2.1 Abbreviations

Table 8-1 List of used abbreviations

Abbreviation	Meaning
ADC	Voltage on the analog-to-digital converter (A/D converter)
AR	Autorange
AUTOCAL	Automatic calibration of analyzer
CAL	Calibration
CAL-Gas	Calibration gas
ELAN	Economical Local Area Network
ERR	Faulty operation of analyzer
IR	Infrared
LCD	Liquid Crystal Display
MEAS	Measure
MR	Measuring range
MV	Measured value
PUMP	Pump on/off
R	Relay or computer mode (remote)
SV	Span (calibration) gas valve
Sync	Synchronization (with other devices in the system)
V-ADCt	
ZV	Zero gas valve

8.2.2 Explanation of Symbols

To avoid danger to the life or health of users or service engineers, and to avoid damage to property, certain sections of text in this Manual are identified by warning symbols (pictograms).



General indication of danger
It is essential to observe the Instruction Manual

8.3 Software Release Versions

This Manual refers to the software release version 2.09._ (see Section 5.7.4). The most important modifications are listed below.

If analyzers are to be upgraded to the software version 2.09._, please observe the listed measures.

Table 8-2 Measures for upgrading to version 2.09._

Software version	Manufacturing period starting	Most important innovations	Measures for upgrading to version 2.09._: Replace ROM package C79451-A3494-S501 and ...
0.24 ... 0.94	Up to approx. 12/96	<ul style="list-style-type: none"> • Functionality completed (pre-production analyzers) 	<ul style="list-style-type: none"> • Only possible in service center! Replace ROM package (flash PROM) C79451-A3494-S501, GAL • New temperature adjustment necessary
1.0	1/97	<ul style="list-style-type: none"> • Complete functionality with German dialogs 	
1.1	1/97	<ul style="list-style-type: none"> • Internal correction 	
1.2	2/97	<ul style="list-style-type: none"> • Complete functionality with German dialogs 	
1.3	2/97	<ul style="list-style-type: none"> • Internal corrections 	
1.4	2/97	<ul style="list-style-type: none"> • Complete functionality with German, English, French, Spanish Italian dialogs 	
1.5	3/97	<ul style="list-style-type: none"> • Signalling "Function control" introduced • Analyzer status displays: "Function control" instead of "Maintenance" (see Section 5.2) 	
1.6	6/97	<ul style="list-style-type: none"> • Error correction in display "O₂ cal after install date" (see Section 5.8.2.1) • In dialog "Parameters: Time constants" T90 instead of Tau (T63) (see Section 5.9.3) • Company name "SIEMENS" removed • Internal corrections 	<ul style="list-style-type: none"> • Check time constant

Table 8-2 Measures for upgrading to version 2.09._, continued

Software version	Manufacturing period starting	Most important innovations	Measures for upgrading to version 2.09._: Replace ROM package C79451-A3494-S501 and ...
2.0._	11/97	<ul style="list-style-type: none"> • Variable chopper frequency (factory setting) • Language selection introduced (see Section 5.10.2.1) • Error eliminated: With AUTOCAL time = 0 h, analyzer remains in warm-up mode • Response of analog current output with function control can now be parameterized (see Section 5.10.1.1) • The dialogs "Analyzer status: factory settings hardware" and "Analyzer status: factory settings software" revised • In dialog "Analyzer status: Diagnostic values: O₂ diagnostic values", the sensor voltage is displayed in mV • Error eliminated: relay signalling measuring range 1/2 • Maintenance switch omitted. Instead signalling "Function control" if the analyzer is uncoded (see Fig. Fig. 5-2) • Limits with fixed hysteresis of 2 % of measuring range (see Section 5.9.2) • Display of current measuring ranges in "Analyzer status: Diagnostic values: IR diagnostic values: Not corrected conc." (see Section 5.7.2.1) 	<ul style="list-style-type: none"> • Check corresponding parameters
2.01_	3/98	<ul style="list-style-type: none"> • Error correction: texts in menu "O₂ zero calibration" in English, French, Spanish, Italian 	
2.02_	5/98	<ul style="list-style-type: none"> • The automatic determination of the synchronous rectifier phase has been improved (error message "Phase not found") 	
2.03_	9/98	<ul style="list-style-type: none"> • RS485 interface (ELAN) completed 	<ul style="list-style-type: none"> • Check ELAN parameters

Table 8-2 Measures for upgrading to version 2.09._, continued

Software version	Manufacturing period starting	Most important innovations	Measures for upgrading to version 2.09._: Replace ROM package C79451-A3494-S501 and ...
2.04_	11/98	<ul style="list-style-type: none"> • Error correction: sporadic measured-value spikes with ambient temperatures > 40 °C. 	
2.05_	3/99	<ul style="list-style-type: none"> • Error correction: display of parameters following acknowledgment of "Accept modifications" by NO not always updated. 	
2.06_	2/00	<ul style="list-style-type: none"> • The option module "PROFIBUS-DP" or "-PA" including 8 additional relay outputs and 8 binary inputs is supported. • Error correction: measured values at analog output are not always stored during faults if the measured value changes range. • Set LCD contrast to basic state: press the three arrow keys simultaneously. • The command "Remote" via the RS485 interface (ELAN) results in signalling of "Function check" to identify an intervention on the analyzer. • The number of digits following the decimal point (resolution) dependent on the measuring range has been optimized. • The factory status can be generated again by using the function "Load factory data". • The current status is now always displayed in the menu "IR source ON/OFF". • Pressure sensor can measure up to 600 mbar without error message (previously 700 mbar). 	<ul style="list-style-type: none"> • Set PROFIBUS address. Parameterization of additional relay outputs and binary inputs. • No factory data are stored in the analyzer when upgrading from versions <= 2.05.

Table 8-2 Measures for upgrading to version 2.09._, continued

Software version	Manufacturing period starting	Most important innovations	Measures for upgrading to version 2.09._: Replace ROM package C79451-A3494-S501 and ...
2.07_	7/00	<ul style="list-style-type: none">• Extension of communication via RS485/ELAN• Saving/reloading factory data in/from EEPROM.	
2.08_	8/00	<ul style="list-style-type: none">• Internal correction	
2.09_	12/00	<ul style="list-style-type: none">• Larger range of adjustment for LCD contrast	

Siemens AG
A & D PI
Process Instrumentation
and Analytics
D-76181 Karlsruhe

© Siemens AG 2001
All rights reserved

Siemens Aktiengesellschaft

Order No. C79000-B5276-C216
Printed in France
AG 0101 MG 154 De