

IndraMotion MTX micro

The compact CNC system for standard machines



IndraMotion MTX micro – profitability with complete functional range

The market for CNC machine tools is very diverse today and also requires low-cost control and drive solutions for standard turning and milling machines. CNC system IndraMotion MTX micro from Rexroth is the ideal tool for these applications and is exceptionally affordable.

IndraMotion MTX micro is the compact, simple, powerful, and nevertheless low-cost CNC solution from Rexroth for standard turning and milling machines. It consists of a custom HMI interface and a compact multi-axis drive controller with high-capacity CNC control and PLC.

Advantage

- ▶ easy to use and practical
- ▶ ultra-high reliability and production accuracy – down to the nanometer
- ▶ machining times minimized thanks to a high-performance 32-bit processor
- ▶ fast, easy commissioning of the turnkey system
- ▶ small installation space in control cabinet required to accommodate compact multi-axis drive controller
- ▶ direct connection to 200 - 500 V, 50 - 60 Hz supply mains without a transformer

All of these advantages make IndraMotion MTX micro the most compact and high-performance CNC in its class.



▲ **IndraMotion MTX micro is the economical CNC system solution from Control City – your control technology capital – for standard turning and milling machines.**

www.control-city.com

▼ **Winner of the Ringier Technology Innovation Award 2009 METALWORKING: IndraMotion MTX micro from Rexroth**



金属加工业 荣格技术创新奖
Ringier Technology Innovation Awards 2009 METALWORKING

IndraMotion MTX micro is the perfect CNC system for:

- ▶ turning machines and basic turning centers
- ▶ drilling machines
- ▶ milling machines
- ▶ basic machining centers

Features

- ▶ operating panels and software optimized for turning and milling machines
- ▶ comprehensive technology-cycle library for easy, efficient solving of complex machining tasks
- ▶ multiple technological functions for complete machining
- ▶ compatible with the standard, performance and advanced versions of IndraMotion MTX
- ▶ preconfigured software for turning and milling
- ▶ open PLC per IEC 61131-3 for application-specific enhancements
- ▶ engineering tools for easy, fast commissioning and diagnosis



Turning – precise and complete

IndraMotion MTX micro offers all functions and options for the standard turning machine without option list:

- ▶ constant surface speed
- ▶ tapping with or without compensating chuck
- ▶ spindle turret axis
- ▶ turning, drilling and milling cycles for complete machining

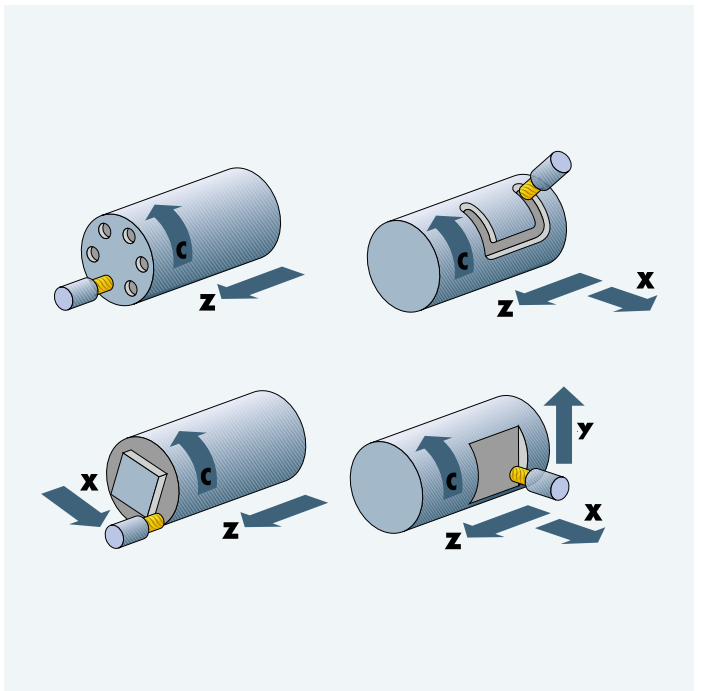

▲ Operating panel for turning machines

- high-resolution color TFT display, 21.3 cm (8.4")
- IP54 protection at the front
- compact machine user panel
- interface for inserting a USB memory stick
- integrated hand wheel
- emergency stop button
- start/stop button
- 24 V DC connection voltage

▲ Drilling and milling functions for complete machining

- C axis machining with live tools
- cylinder surface machining
- end-face machining

Milling – quick and efficient

IndraMotion MTX micro covers the complete range for the standard milling machines:

- ▶ 2.5 D and 3D machining using up to 4 interpolating axes
- ▶ direct programming of drawing measure
- ▶ free positioning of the workpiece coordinate system in space
- ▶ drilling, milling and turning cycles for complete machining



- ▲ **Operating panel for milling machines**
 - high-resolution color TFT display, 26,45 cm (10.4“)
 - IP54 protection at the front
 - compact machine user panel
 - emergency stop button
 - interface for inserting a USB memory stick
 - connection for mobile hand wheel
 - start/stop button
 - 24 V DC connection voltage

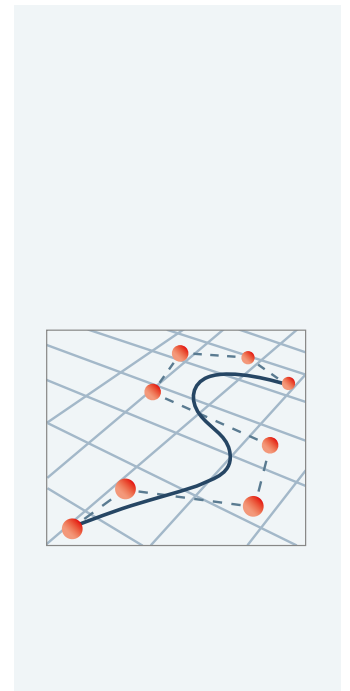
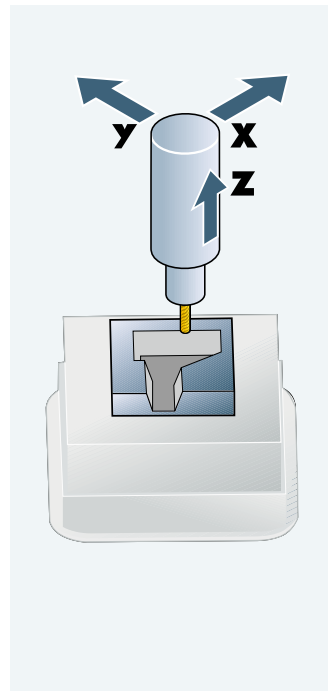

- ▲ **Functions for highly precise, fast machining**
 - axis-specific jerk limitation
 - 1,000 NC blocks with look-ahead function
 - spline interpolation
 - B-spline compressor
 - nanometer interpolation

User friendly operation and programming

The customized operating panel combines all functions, from visualization, to machine operation, to programming in a single unit – IndraControl VDP 80. The control panel is available in two variants for turning and milling machines and can be ordered with a light or darker tone.

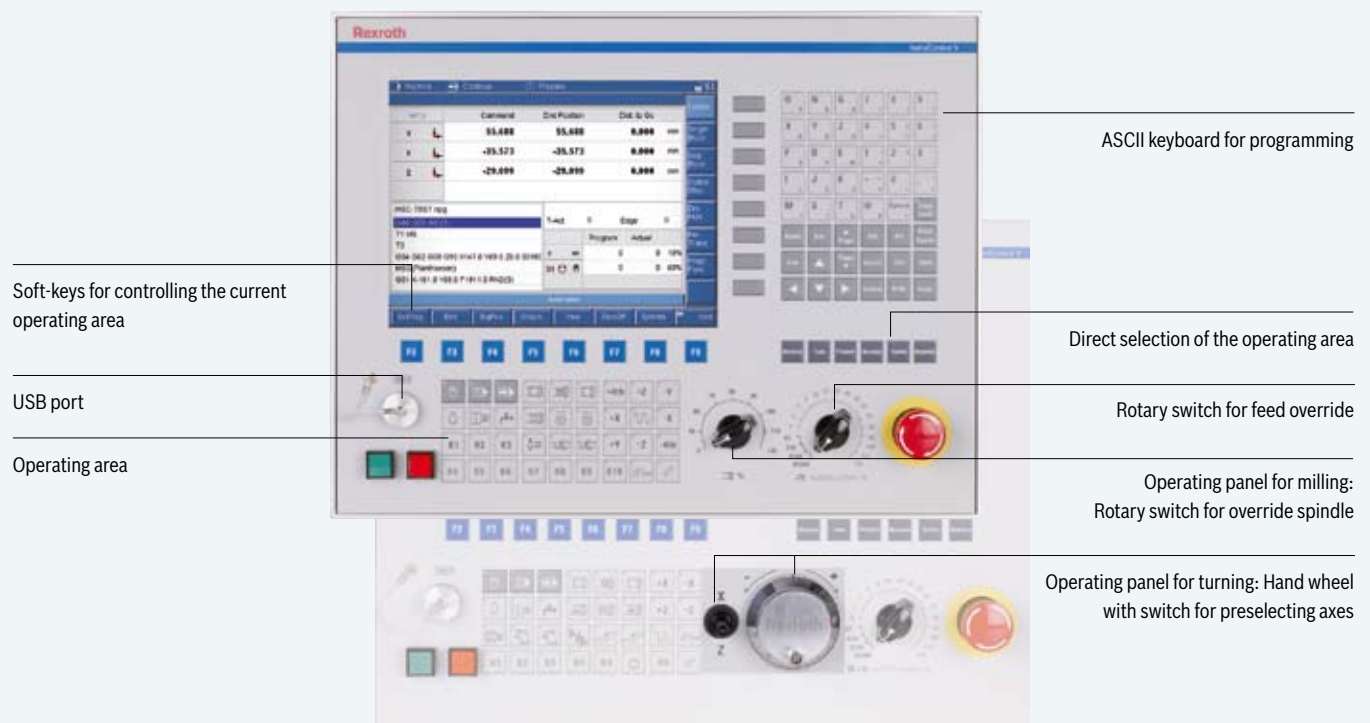

◀ The operating panel is available in light and dark tones.

The software assists the operator in all tasks by providing intuitive dialog screens, e.g.:

- ▶ set-up the machine
- ▶ prepare the tools
- ▶ develop and process the NC programs
- ▶ change parameters
- ▶ diagnose problems

Standard languages are German, English and Chinese, with additional languages available upon request.

Convenient editor functions facilitate NC programming and running in programs. The user interface is available in multiple languages, which can be toggled without having to restart the control system.

A user administration facility enables access to be restricted to specific functions so that the machine can be operated safely and reliably.

Alarms and messages are output in plain text and documented in the integrated log book.

Selected operating mode

Current diagnosis

Selected operating area

Active channel

Selection of machine functions

Program status displayed

Functions of operating area

WCS	Command	End Position	Dist. to Go	Unit
X	-5.088	-5.088	0.000	mm
Y	-0.839	-0.839	0.000	mm
Z	13.709	13.709	0.000	mm

/act/HSC-TEST.npg

G46 G08 JKC(1) ActTool 0 Edge 1

T1 M6

G54 G62 G00 G90 X147.0 Y69.0 Z0.0 S1000

G01 X-101.0 Y-1.0 F1911.0 RND(5) F #* mm Program Actual 0.00 0.00 80%

X-101.0 Y-1.0

X99.0 Y-1.0

Automatic

SelfProg Edit BigPos ViewOfs ZeroOfs Variables Monitor Next

Cycles – parameterize instead of program

IndraMotion MTX micro features numerous technology cycles for standard machining processes. The comprehensive library covers even combined turning and milling work. Intuitive user guidance makes it easier to select a cycle and enter parameters. Dialogs provide information in text and graphical form. Everything remains straightforward thanks to practical pre-assignment of parameters. Even complex machining tasks can be carried out very quickly. This, in turn, improves efficiency and helps to avoid errors.

Examples

Turning



Drilling



Milling

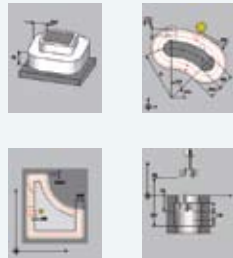

Contouring

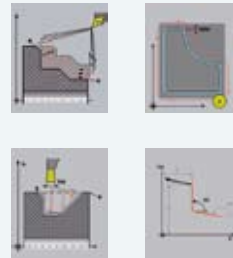

Engraving



Cycle input dialog

Graphical assistance for every parameter

Parameter	Comment	Value
SR	* Starting point diameter	0
SA	* Starting point longitudinal direc	3
ER	* End point diameter	12
EA	* End point longitudinal direction	-30
CD	* Depth of cut	2

Brief description of parameter

View optional parameters for experts

Plausibility protocols of parameters entered

Contour cycles are used to easily program and efficiently machine turning and milling workpieces. Workpiece contours are described with DIN G-Code and the dimensions for lines, radii and chamfers copied into the program directly from the workpiece drawing. The contour cycles calculate automatic cut segmentation during machining and ensure efficient tool guidance. Threads, grooves, undercuts and pockets are then simply added via parameter configured technology cycles.

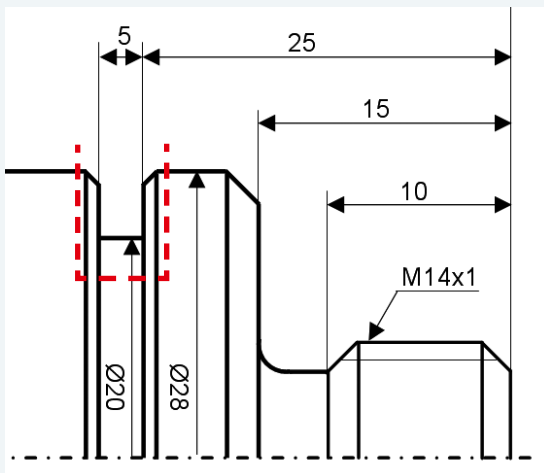

1

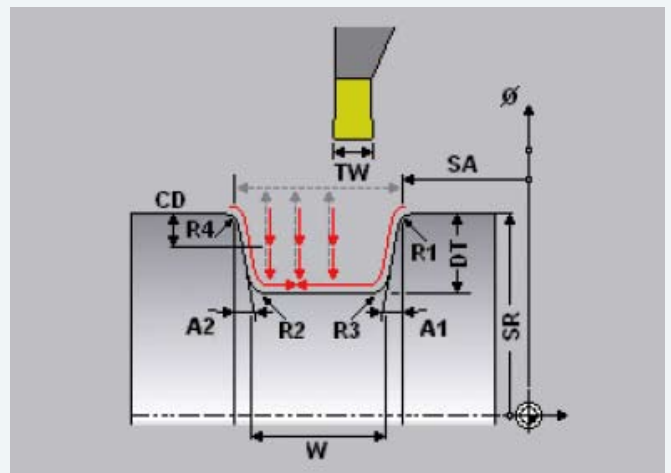

2

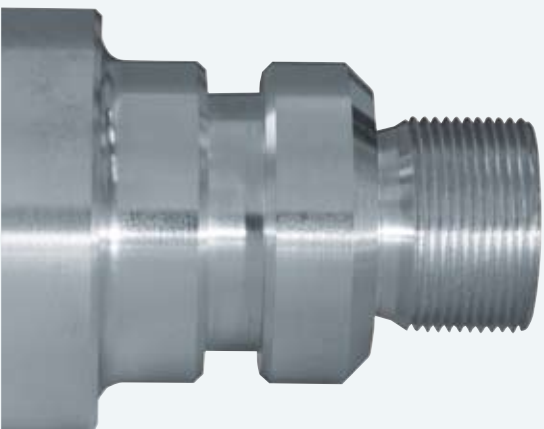

3

```
G0 G18 G54 G90 DIA
T2 M6
G95 G96 S200M3 F.125
X30 Z-20
// Form groove
G191(OR18,SR30,SA-25,W5,DT-5,TW2)
T3 M6
G95 G96 S200 M3 F.25
X18 Z-10
```

Efficient CNC programming

NC functions with syntax according to DIN 66025

The conversational NC programming – movement sequences and their boundary conditions (geometry, kinematics, dynamics, corrections, etc.) are described using DIN programming. Standard programming is a language only for writing commands that control movements at the machine and specific machine functions.

The NC functions with high-level language syntax enhance

G-code programming according to DIN 66025 to include additional performance functions for effective NC programming. The syntax also makes it easier to understand the NC program. Example: scale (long form) or SCL (short form) for enlarging or reducing a programmed contour.

The CPL programming (Customer Programming Language)

is rooted in the BASIC high-level language standard and can therefore be easily learned. CPL can be used for variable programming, mathematical operations, control structures such as REPEAT, WHILE, FOR, IF, CASE, GOTO and access to system states.

Using CPL leads to:

- ▶ shorter NC programs for repeat procedures and similar program segments
- ▶ condition-based program variants
- ▶ universally applicable subprograms

User cycles

DIN and CPL programming can be used to create separate cycles. Simple configuration of the graphical input support allows them to be seamlessly integrated into the system next to the technology cycles.

NC editor

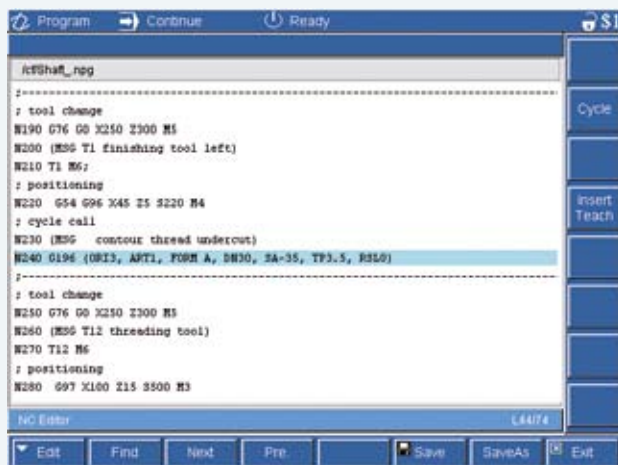

Cycle selection

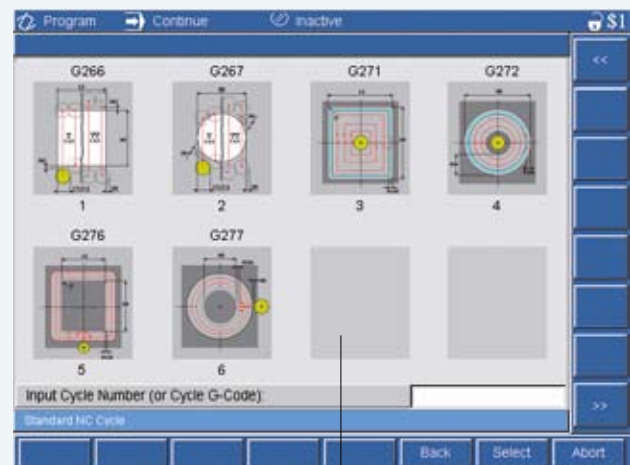

Conveniently enter user cycles into the system here.

Flexible setup functions

Tool management

The tool management facility is easy to use and can be adapted to the machine:

- ▶ up to 999 tools, 16 cutting edges per tool
- ▶ geometry and wear corrections
- ▶ tool life management
- ▶ radius correction, cutting edge correction
- ▶ angle head tools
- ▶ fixed-place coding/variable coding
- ▶ alternate tools

Set workpiece and tool zero points

Intuitive dialogs for setting the zero points for workpieces and tools assist the operator during routine work. This simplifies the process of setting up the machine and reduces the time required for this – minimizing mistakes.

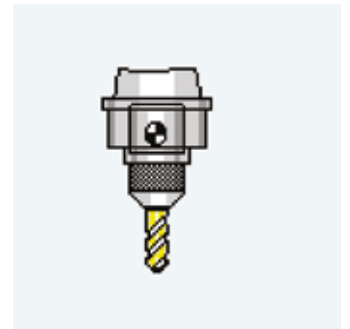
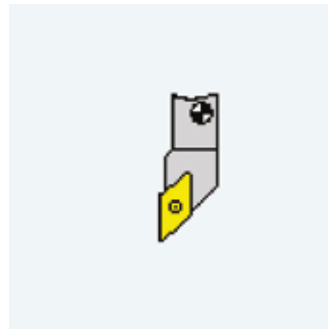

Toolset

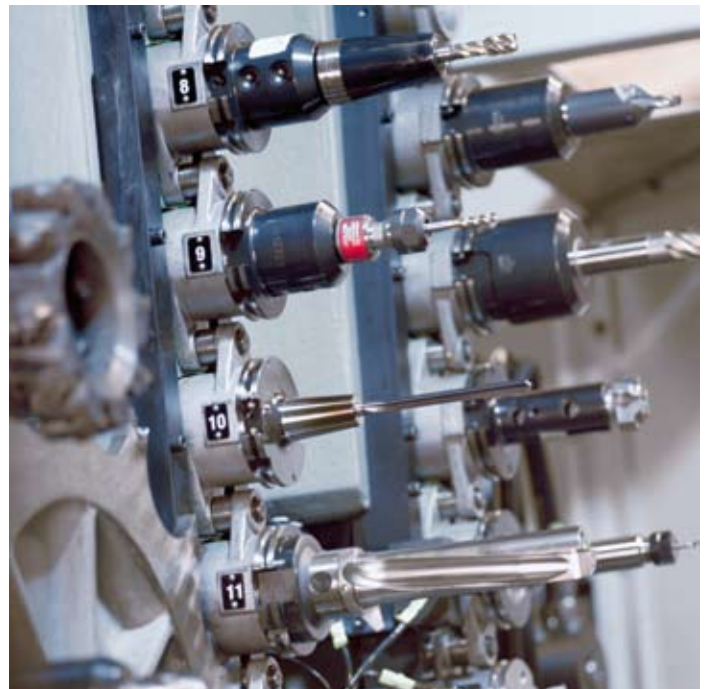
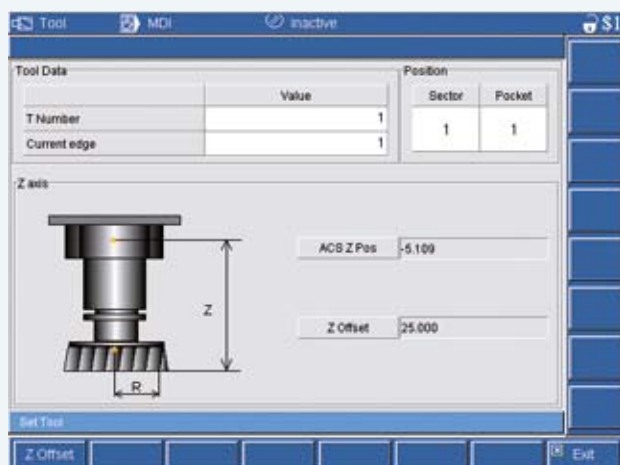

Impressive performance

Maximum precision

- ▶ high-resolution processing of command and actual positions ensures precision machining down to the nanometer.
- ▶ the absolute encoders for the servo motors, with a resolution of $2^{21} = 2,097,152/\text{revolution}$, provide for high control quality.
- ▶ optional use of multiturn absolute encoders eliminates the need to reference the servo axes after the machines have been activated, even when long traversing ranges are involved.
- ▶ special compensations in the drive take non-linearities in the mechanicals into account.
- ▶ all parameters required for operation are stored in the encoder data memory in a fail-safe manner.

Dynamic movements for short machining times

Intelligent drive technology meets the demanding requirements for control quality and dynamics of the servo axes.

- ▶ all control functions are implemented close to the drive to achieve fast clock rates of up to $125 \mu\text{s}$.
- ▶ the default parameter settings of the system typically eliminates the need for further optimization.
- ▶ numerous options for making filter settings (e.g. electric current target value filter, axis-specific jerk limitation) meet the requirements for particularly dynamic motion sequences; autotuning, an oscilloscope function and integrated testing functions minimize commissioning times.

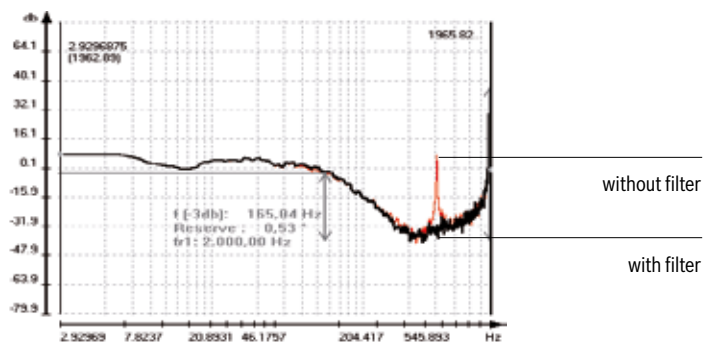

▶ **Filter settings (e.g. electric current target value filter) enable very dynamic axis movements with ultra-high machining accuracy.**

◀ **Precision machining down to the nanometer with IndraMotion MTX micro**

Direct communication

Program execution via network

- ▶ easy integration of IndraMotion MTX micro into an existing network infrastructure using Ethernet and TCP/IP
- ▶ practically unlimited storage space for CNC programs and data
- ▶ slim transfer protocol ensures fast data transmission with minimum load placed on the processor
- ▶ seamless integration of external CNC data in the IndraMotion MTX micro file system via network drives

Remote maintenance and diagnostics

TCP/IP communication allows a connection to be made to an office PC and CNC control system. This, in turn, makes it possible to carry out diagnostics from a control station or even perform remote maintenance over the Internet.

Direct program execution via external storage media

- ▶ a USB port on the front of the control panel can be used to connect external storage media such as a USB memory stick
- ▶ integration of storage media in the file system of the controller enables direct selection of NC programs (copying not necessary)

- ▼ **Integration of IndraMotion MTX micro in existing network**
 - remote maintenance over the Internet
 - program execution over the network
 - backups or program execution using a USB memory stick

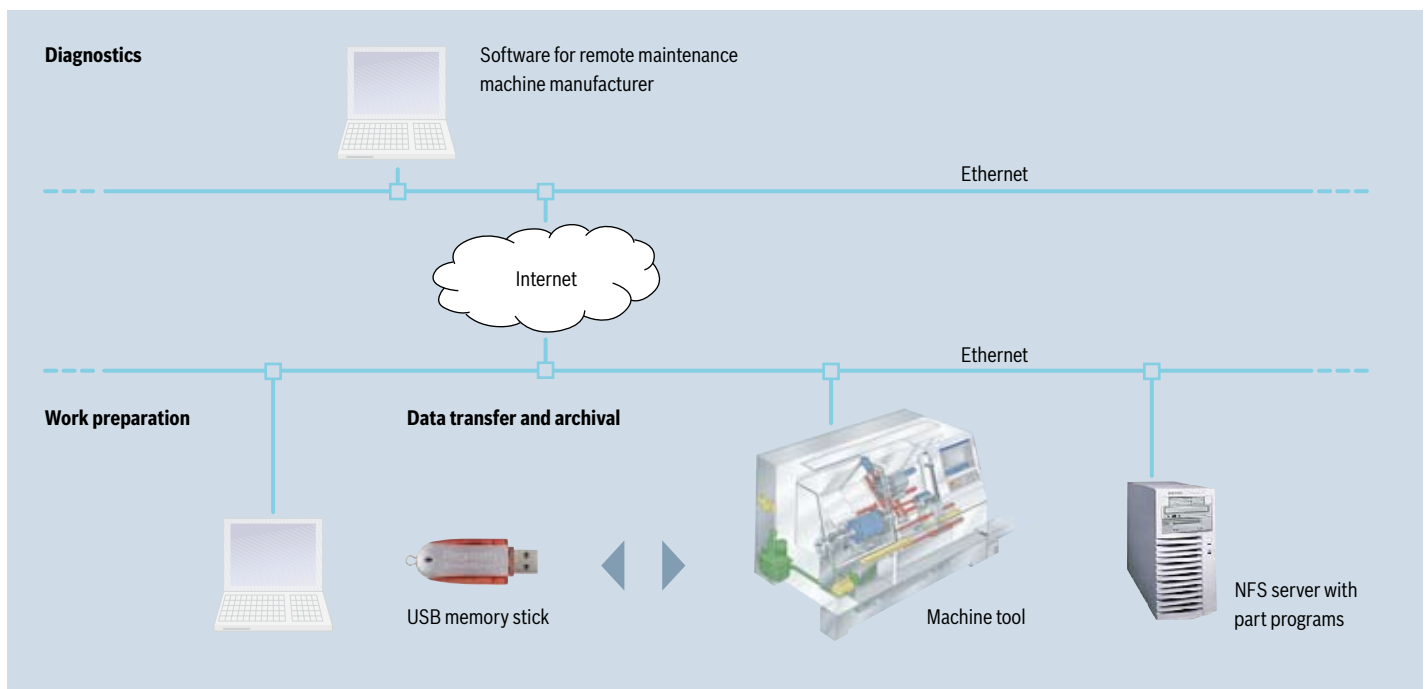

Easy installation and commissioning

IndraMotion MTX micro from Rexroth raises the bar when it comes to easy installation and commissioning of a high-performance CNC system. Basic projects are provided for applications involving a typical CNC machine. A turning machine, milling machine or turning center can thus be parameterized in no time by loading the software. You can then concentrate on what matters most: the machine itself.

The high level of system integration also offers decisive advantages with respect to assembly and maintenance:

- ▶ minimum number of modules
- ▶ easy wiring
- ▶ screwless terminals
- ▶ ultrahigh availability
- ▶ maintenance-free hardware

Easy Setup Documentation

The compact setup documentation is easy to understand but also comprehensive, since all relevant information is provided for you to quickly commission the CNC system.

List of contents

- ▶ choosing and connecting hardware
- ▶ basic software installation
- ▶ basic project and general settings
- ▶ PLC commissioning
- ▶ commissioning and optimization of the drives
- ▶ IndraMotion MTX micro operating software
- ▶ connection diagrams
- ▶ overview of parameters
- ▶ standard I/O assignment



Comprehensive service portfolio

We offer you not only a complete range of drive and control solutions, but also an in-depth consultancy expertise and a best-in-class service portfolio: from conceptual development above commissioning to modernization – for an economical lifecycle of the machine.

Industry-focused engineering and applications support

Our experienced team of industry experts provides advice and support to assist you during conceptual development and design of your solution:

- ▶ selection of specific automation components (hardware and software) for your application
- ▶ detailed description of control and drive components, interfaces and data management
- ▶ development of sample applications
- ▶ active involvement in initial applications at your site
- ▶ support during integration of Ethernet-based SERCOS III real time communications
- ▶ individual support for the systematic and compliant issue of safety strategies

Software and hardware engineering

Rexroth provides expert advice and support to assist you during development of your production systems and networks. IEC-compliant PLC function modules and NC cycles for nearly all industry sectors are available in our software library.

Commissioning

Our technical support experts are right at your side whenever you need fast, professional assistance during the commissioning phase. Each of our teams are made up of service engineers who specialize in a particular industry.

Service

Our service team supports you throughout the planning, installation, commissioning, operation and extended life phases:

- ▶ technical support/helpdesk
- ▶ field service
- ▶ repairs service
- ▶ spares service
- ▶ retrofit and modernization
- ▶ industry-focused training



Example: a simple turning machine with 2 axes and 1 spindle

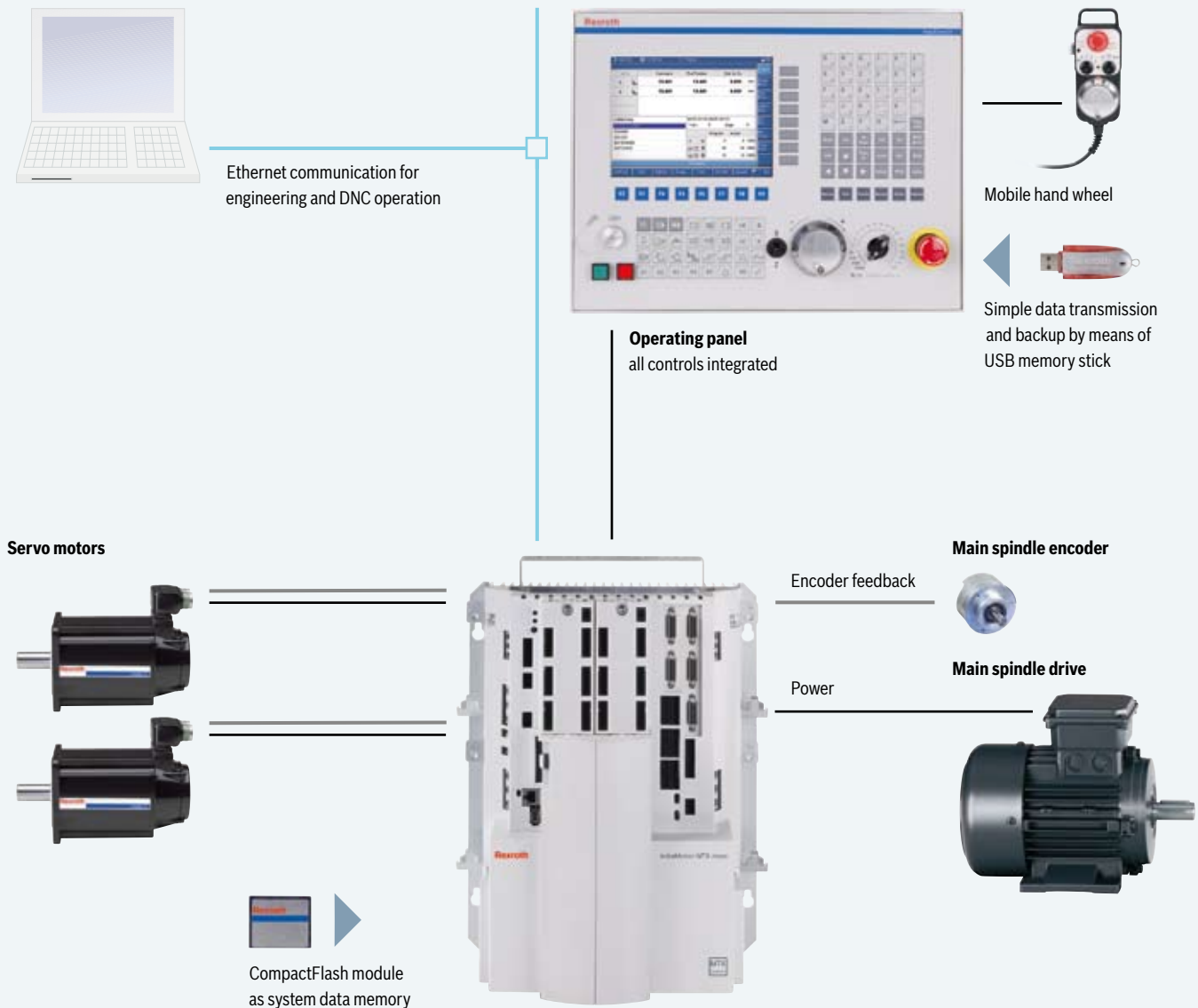

Multi-axis drive controller

- ▶ integrated control with CNC kernel and IEC 61131-3 compliant PLC
- ▶ high-end servo functions
- ▶ HMI function
- ▶ modular expandable I/O assembly
- ▶ simple direct connection for 24 VDC I/O signals
- ▶ no adaptation transformer required
- ▶ cable for power and encoder feedback pluggable on both ends
- ▶ integrated frequency converter to actuate standard asynchronous motors of up to 11 kW
- ▶ connection to external main spindle encoder

Example: turning centers and milling machines with 3 axes, 1 spindle, and 2 additional axes

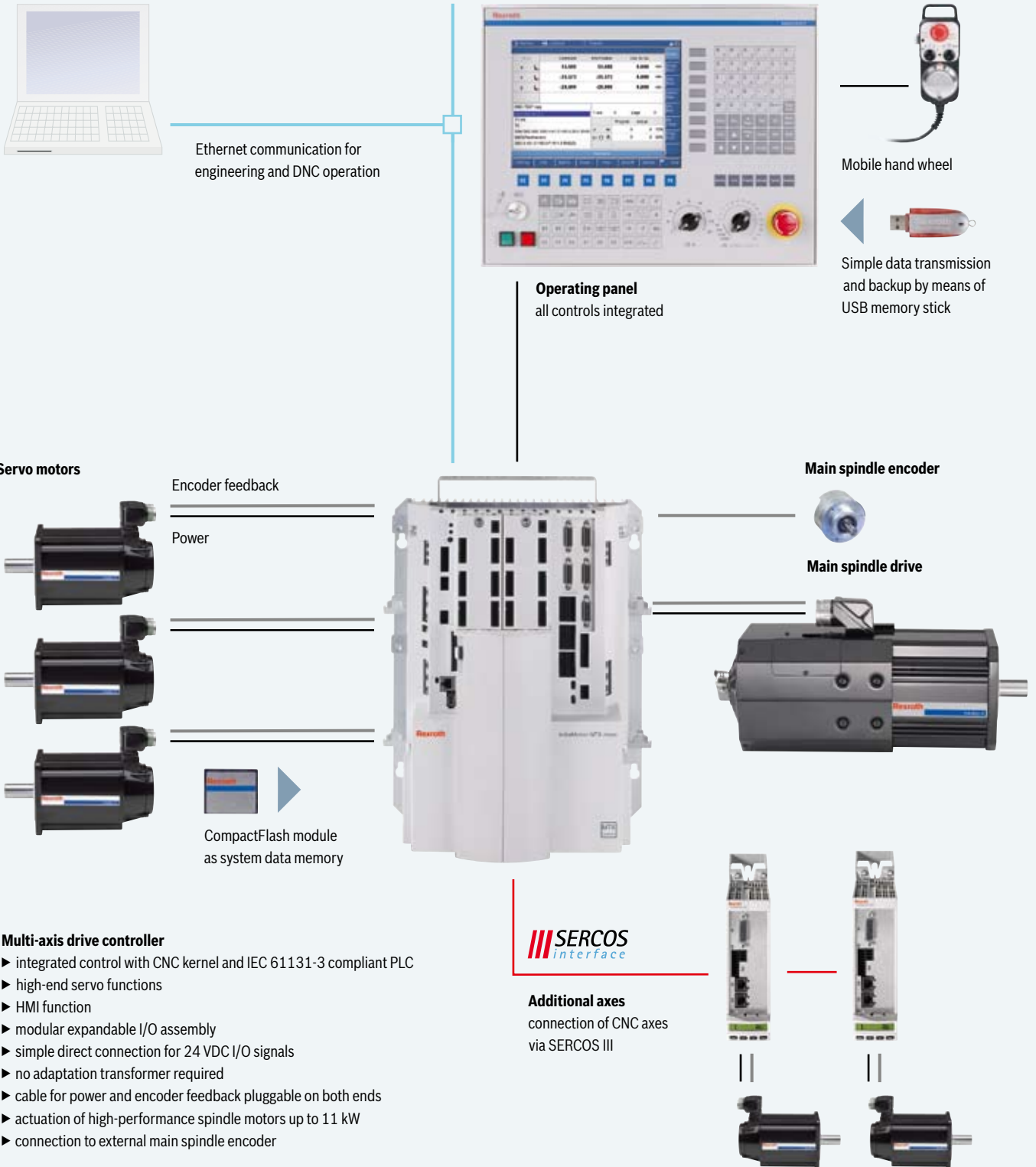

Technical data

1	Technology		
1.1	Turning		●
1.2	Drilling		●
1.3	Milling		●
2	Axis control		
2.1	Number of axes (3 axes variant/4 axes variant)	3/4	●
2.2	Additional axes via SERCOS III (3 axes variant/4 axes variant)	3/2	○
2.3	Max. number of spindles thereof	2	●
2.4	Number of independent channels	2	●
2.5	Max. number of interpolating axes per channel	4	●
2.6	Spindle/C axis switching		●
2.7	Channel-crossing axis transfer		●
2.8	Software limit		●
2.9	Additional spindle encoders	1	●
3	Interpolation functions		
3.1	Linear interpolation with/without exact stop		●
3.2	Circular interpolation with radius and center-point programming, helical interpolation, tangential entry		●
3.3	Tapping with/without compensating chuck		●
3.4	Thread cutting		●
3.5	NC block preview, look-ahead with jerk limitation		●
3.6	Jogging with active transformation		●
3.7	Nanometer resolution		●
4	Feed function		
4.1	Feed with mm/min or inch/min		●
4.2	Time programming		●
4.3	Feed rate per revolution		●
4.4	Constant surface speed		●
4.5	Feed on positive stop		●
4.6	Torque reduction		●
5	Displacements and corrections		
5.1	Mirroring, scaling, rotating		●
5.2	Zero-point offset		●
5.3	Placements (FRAMES) – coordinate displacement and rotation in the space		●
5.4	2D compensation		●
6	Tool management		
6.1	Integrated tool management with database for up to 999 tools		●
6.2	Tool data entry and organization of tool lists		●
6.3	Tool corrections (length, radius, edge length, user data)		●
6.4	Standstill time management		●
6.5	Access to tool data from PLC and CNC		●

● Standard ○ Optional ¹⁾ not at 3 axes variant (HCT)

7	CNC programming				
7.1	Parts program development		DIN ISO 66025/RS274		●
7.2	High level language CPL (Customer Programming Language)				●
7.3	CNC memory		64 MB		●
7.4	Static memory		4 MB		●
7.5	Max. parts program size		8 MB		●
7.6	CompactFlash data memory				●
7.7	Technology cycles for turning, drilling, milling				●
7.8	Cycles for contour machining for turning and milling				●
8	Functions				
8.1	Dwell time in seconds				●
8.2	Acceleration programming, loop gain programming				●
8.3	Homing through the NC program				●
8.4	Absolute dimension, relative dimension				●
8.5	Switching between inch/mm				●
8.6	Probe, static/on-the-fly measurement				●
8.7	Roundings and chamfers				●
8.8	Corner rounding with splines				●
8.9	NC set command from PLC				●
8.10	NC programm restart/block search				●
8.11	Dry Run				●
8.12	Retracting from and returning to the contour				●
9	PLC functions				
9.1	Integrated PLC: IndraLogic with programming languages IEC 61131-3 (IL, LD, FBD, ST, SFC, CFC)				●
9.2	PLC program memory		2 MB		●
9.3	Number of I/O		32 I/16 O		●
9.4	Max. number of I/O		96 I/48 O		○
10	Diagnosis and commissioning tools				
10.1	Automatic system diagnoses				●
10.2	Status and error messages in plain text (languages: Chinese, English)				●
10.3	Integrated drive setup tools				●
10.4	Drive oscilloscope				○
10.5	Integrated PLC setup tools				○
10.6	Engineering tool IndraWorks				○
11	Drive system				
11.1	Mains voltage three phases at the networks TT, TN-C, TN-S, IT		200 – 500 V ±10 %		
11.2	Mains frequency		50 – 60 Hz ±2 Hz		
11.3	Mains connection capacity with power choke		30 kVA		
11.4	Rated current		44 A		
12	Servo motors	Axis 1	Axis 2¹⁾	Axis 3	Axis 4
12.1	Controlled servo drive	●	●	●	●
12.2	Standstill torque M_0 [Nm]	28	17	12	12
12.3	Rated current I_n [A]	35	20	14	14
12.4	Maximum current I_{max}	50	50	27	27
13	Spindles				
13.1	Controlled main spindle drive (Closed Loop)	●	●	–	–
13.2	Standard asynchronous spindle motor (Open Loop)	●	●	–	–
13.3	Rated capacity P_n [kW]	11	5	–	–
13.4	Connection to external spindle encoder	●	●	–	–

Bosch Rexroth AG

Electric Drives and Controls

P.O. Box 13 57

97803 Lohr, Germany

Bgm.-Dr.-Nebel-Str. 2

97816 Lohr, Germany

Phone +49 9352-40-0

Fax +49 9352-40-4885

www.boschrexroth.com/electrics