

Item No.:

Qty.:

Project:

## CP NEXT



Cp Next, the Irinox propane holding cabinet, encloses in compact dimensions all the technical and functional know-how that allows the professional to set and maintain the chosen temperature constant, manage the most suitable humidity level for the stored products, distribute evenly on all positioned trays a gentle ventilation that does not dry out the products. On the contrary, it keeps its nutritional values, aromas, colours and consistency intact.

### Capacity

	Double door	Single door
Number of trays (600x800) pitch 35 mm	37	42
Number of trays (600x800) pitch 52.5 mm	26	28
Number of trays (600x400) pitch 35 mm	76	84
Number of trays (600x400) pitch 52.5 mm	52	56
Internal cell volume according to EN 16825 (liters)	652	646

### Standard construction details

- Standard door opening on the right with hinges on the right.
- Double bevel door.
- Closure of magnetic and slowed door.
- Double doors right opening (hinges on the right) with door stop opening 130°.
- Ergonomic and robust handle made of steel.
- Internal lighting with double led bar.
- 4.3" capacitive touch screen display.
- Door seal with 5 chambers to guarantee a better temperature seal.
- Internal and external structure completely in AISI 304 stainless steel.
- Built-in air condensation.
- High efficiency cooling system with R290 natural refrigerant gas.
- Fast, effective, innovative adaptive hot gas defrosting allows you to manage and set the time bands of use, to avoid sudden changes in the storage temperature.
- Top of the holding cabinet with a thickness of 135 mm in polyurethane foam.
- Bottom of the holding cabinet with a thickness of 90 mm in polyurethane foam.
- Closing material of the evaporating compartment with a thickness of 40 mm in polyurethane foam.
- USB port for HACCP download.
- Innovative, patented air distribution system allows perfect air distribution on each shelf for the entire height of the cabinet. The double manifold generates three air flows, one central and two lateral, to guarantee a constantly uniform ventilation.
- Passive humidity management created by the perfect balance between the size of the evaporator, the power of the variable speed fans and the power of the compressor.

## Operation

### 4 types of door available:

**Single steel door:** allows you to make the most of the load capacity of the holding cabinet.

**Double steel door:** ideal for optimizing storage in case of intensive use with a high number of daily door openings.

**Single glass door:** allows you to make the most of the load capacity of the holding cabinet, ideal for use as a display unit.

**Double glass door:** ideal for optimizing storage in case of intensive use with a high number of daily door openings and when used as a display unit.

### 2 operating modes available:

**Multi:** with operating temperatures from -25°C to +15°C, with the possibility of setting the holding cabinet on 3 different temperatures: Negative (-25°C / -5°C), Chocolate (+10°C / +15°C) or Positive (-5°C / +15°C), for maximum flexibility of use.

**Up:** with operating temperatures from -5°C to +15°C, with the possibility of setting the holding cabinet on 2 different temperatures: Positive (-5°C / +15°C) or Chocolate (+10°C / +15°C).

### Humidity management

Passive humidity regulation with the selection of 6 different humidity levels (from 40% to 95% RH). The humidity control is active only if the holding cabinet temperature is above 0°C.

### Interface

**4.3" display** with capacitive colour screen. Equipped with buzzer.

### Connectivity

FreshCloud® is Irinox's IOT technology that allows you to control and interact with Cp Next at any time via an APP.

The application features are:

- Remote monitoring of the operation and parameters of the cycle in progress
- Push notification system
- Usage statistics viewing
- HACCP data backup

## Optional

- Sanigen® (Irinnox patented sanitization system).
- Water condensation available for CP Next Multi.
- Pairs of additional guides.
- 4 wheels, 2 of which with brake.
- Lowered feet.
- Door reversibility hinge kit
- Stainless steel spacers for CP Next units side by side.
- Door/s opening left (hinged on the left).
- Special voltages on request.
- Door stop 115° only for CP Next stainless steel single door.
- Condenser air filter.
- Pastry trays holder large + 20 pair of guides (at the place or in addition of standard one).
- Additional pair of pastry guides "Large".
- Lockable door.
- Sound absorbing upper covering (H=7 cm, only for EU).
- Unit sent without gas charge.

## Product warranty

- 2 years from the date of installation, after sending the installation report, on the parts (see warranty condition).

Item No.:

Qty.:

Project:

## CP NEXT

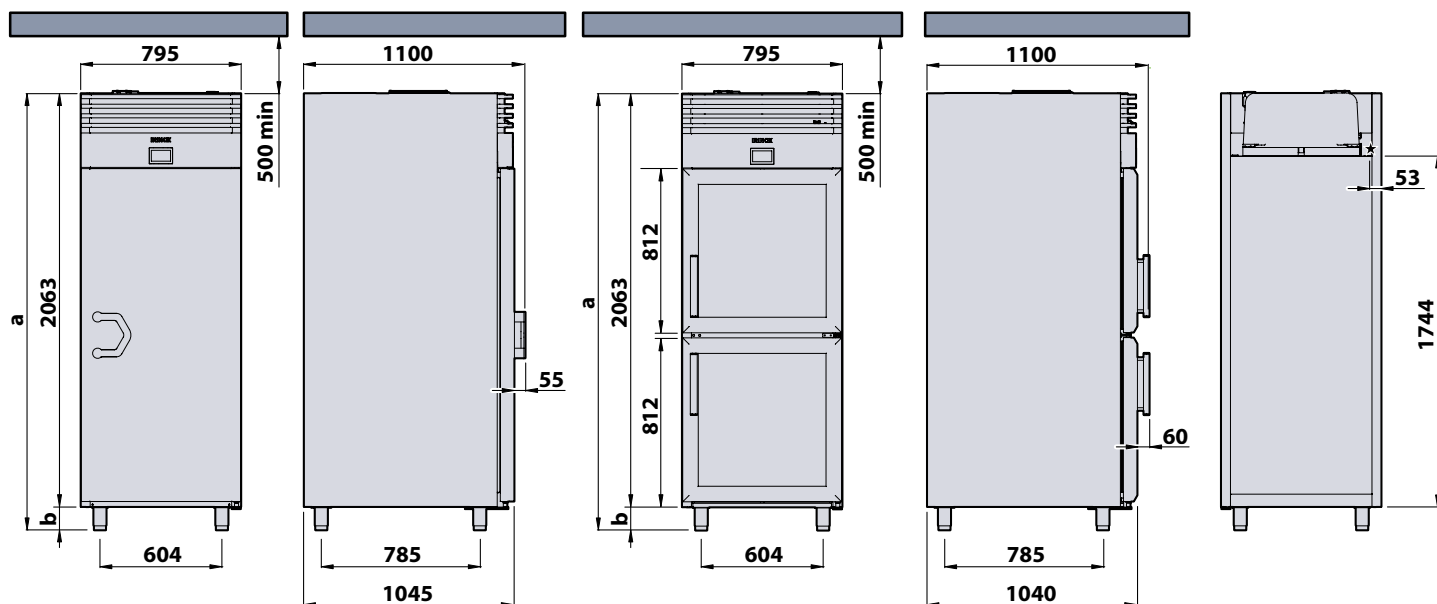

### HEIGHT

		a	b
Standard feet	mm	2178 - 2228	115 + 165
Lowered feet option	mm	2143 - 2178	80 + 115
Wheel options	mm	2218	155

Measures in millimetres

★ Main power cable

## TECHNICAL SPECIFICATIONS

Electric supply	220-240V -1N+PE 50Hz						
		UP		MULTI			
Performance		AIR COOLED		AIR COOLED		WATER COOLED	
Condensation type		ST. STEEL DOOR	GLASS DOOR	ST. STEEL DOOR	GLASS DOOR	ST. STEEL DOOR	GLASS DOOR
Configuration							
Power rating	W	641	742	1106	1207	1092	1192
Full load amps (FLA)	A	3,97	4,41	6,70	7,14	6,58	7,02
Main power cable	mm <sup>2</sup>	3G1.5		3G1.5		3G1.5	
Refrigeration yield (-10°C/+40°C)	W	694		1729		1729	
MAX Condenser rating (-10°C/+40°C)	W	1027		2514		2514	
MIN air flow for ventilation	m <sup>3</sup> /h	680		950		-	
IN/OUT water connections	NPTf	-		-		1/2"	
MAX water consumption (IN temp +30°C/ OUT temp +35°C)	l/h	-		-		440	
MIN/MAX inlet water temperature (water loop)	°C	-		-		+10°C / +22 °C	
MIN/MAX inlet water temperature (water tower)	°C	-		-		+23°C / +35 °C	
Refrigerant type	-	R290 - 0.15 kg		R290 - 0.15 kg		R290 - 0.11 kg	
Climate class	-	class 5 = 40°C - 40% relative humidity		class 5 = 40°C - 40% relative humidity			
Cabinet dimension (width x depth)	mm	795 x 1100		795 x 1100			
Internal cabinet dimension (width x depth x height)	mm	635 x 835 x 1500		635 x 835 x 1500			
Cabinet weight	kg	210	235	210	235	210	235

Item No.:

Qty.:

Project:

## TECHNICAL SPECIFICATIONS

Electric supply	220-230V -1N+PE 60Hz				
		UP		MULTI	
Configuration		ST. STEEL DOOR	GLASS DOOR	ST. STEEL DOOR	GLASS DOOR
Performance					
Power rating	W	625	726	1524	1650
Full load amps (FLA)	A	3,61	4,05	8,60	9,10
Main power cable	mm <sup>2</sup>	3G1.5		3G1.5	
Refrigeration yield (-10°C/+40°C)	W	833		2075	
MAX Condenser rating (-10°C/+40°C)	W	1232		3017	
MIN air flow for ventilation	m <sup>3</sup> /h	680		950	
Refrigerant type	-	R290 - 0.15 kg		R290 - 0.15 kg	
Climate class	-	class 5 = 40°C - 40% relative humidity		class 5 = 40°C - 40% relative humidity	
Cabinet dimension (width x depth)	mm	795 x 1100		795 x 1100	
Internal cabinet dimension (width x depth x height)	mm	635 x 835 x 1500		635 x 835 x 1500	
Cabinet weight	kg	210	235	210	235

## ENERGY CONSUMPTION

Electric supply:	220-240V -1N+PE 50Hz				
		UP		MULTI	
Configuration		SINGLE ST. STEEL DOOR	DOUBLE ST. STEEL DOOR	SINGLE ST. STEEL DOOR	DOUBLE ST. STEEL DOOR
Performance					
Energy class (according to UE regulation 2015/1094)		C	C	D	C
Annual energy consumption (AEC)	kWh/year	832	741	2986	2117

### INSTALLATION

The holding cabinet must be installed following and complying with what is stated in the appropriate installation manual. The contents of the manual must be carefully followed to ensure correct operation and to protect the user's rights under the warranty. Continuous product development may require changes to specifications without notice.

### Irinox SpA

Headquarter: Via Caduti nei Lager 1, 31015 Conegliano (TV) Italy  
 Productive Site: Via Mattei, 20 - 31029 - Vittorio Veneto (TV) Italy  
 Tel. +39 0438 2020 | irinox@irinox.com | www.irinoxprofessional.com

