

Item No.:

Qty.:

Project:

MF350.2 2T Pass Thru CO₂ Multi-function Roll-in Blast Chiller and Shock Freezer with natural gas R744 - CO₂



MultiFresh® MyA CO₂ is the first range of multi-function Roll-in Blast Chiller and Shock Freezer designed for the semi-industrial and industrial sectors capable of performing operating cycles with temperatures from +85°C to -35°C thanks to the Irinox-designed CO₂ condensing unit.

Capacity

Trolley Capacity: 4 x GN 1/1

Trolley Capacity: 2 x GN 2/1

Trolley Capacity: 4 x 400x600

Trolley Capacity: 2 x 800x600

Yield

Yield for blast chilling cycle (+90°C/+3°C) kg 350

Yield for shock freezing cycle (+90°C/-18°C) kg 350

Standard Construction Features

- System consisting of cabinet and remote water condensing unit with CO₂ gas, built and tested at Irinox.
- IRINOX BALANCE SYSTEM®: perfect dimensions of the main components of the refrigerator (condenser, evaporator, compressor and ventilation).
- Multi-circuit evaporator, designed by Irinox, protected from the corrosive action of food by an electrochemical cataphoresis treatment.
- High-performance three-phase motor evaporator fans completely made of aluminium and with 5-speed external inverter control.
- Thermostatic electronic valve.
- Maximum cleanliness and hygiene due to rounded corners and components situated in the chamber so that they can be easily accessed and cleaned
- Sunken floor.
- Drain on the left side (different position on request).
- AISI 304 stainless steel cell internal and external finish.
- 80 mm thick cell panels, insulated with high density polyurethane foam.
- Evaporator fan door that can be opened for cleaning and maintenance.
- 5-chamber magnetic door seals with dirt-repellent profile.
- Door frame profiles with anti-moisture resistance.
- Ergonomic mechanical closure handle with internal panic button.
- Pass-thru (front door hinged on the right/ back door hinged on the left).
- 5-point MultiSensor® probe for perfect product temperature control.
- Automatic switch from manual mode (timed) to automatic mode (with probe); MultiFresh® detects whether or not the probe has been activated automatically.
- Condensing unit designed, assembled and tested at Irinox with the following characteristics: water condensation with a temperature range of +7°C/+12°C, minimum water pressure of 1.5 bar, maximum water pressure of 16 bar, pump head of 50 kPa, equipped with all the control and safety systems.
- Sub-critical working cycle, with maximum working pressure below 57 bar and safety valve at 90 bar.
- Semi-hermetic CO₂ compressor.
- A chiller is required, with cooling capacity greater than 30 kW with +12°C/+7°C In/Out water/brine.
- Unit sent without gas charge

Item No.:

Qty.:

Project:

Unique Design and Performance Features

- Available in the PLUS version with the following 9 functions: blast chilling, shock freezing, thawing, holding, chocolate, regeneration, pasteurization, proofing and low temperature cooking. Sanigen® included.
- Manual defrosting at the end of the day (not during the work cycles).
- SANIGEN®: 24-hour sanitization (Irinnox patented sanitization system; it sanitises every part of the chamber).
- The touch screen also works when you are using kitchen gloves.
- R744 refrigerant gas with GWP 1: it's non-flammable, non-toxic and does not require regular checks pursuant to the F-GAS regulation for high GWP synthetic gases.

Optional

- Opposite doors opening.
- Ramps.
- No pass-thru (1 door only).
- Sous-vide core probe.
- Door stop 100° and 120°.
- Magnetic door stop 100°.
- Mirror Unit.
- Knocked down.
- Ventilated floor (only with ramp).
- Reinforced floor in stainless steel 20/10.
- Low temperature kit.
- Wifi Mya.
- Ethernet board.
- Freshcloud connection kit (Ethernet card & wi-fi included).
- Anti-vibration feet for condensing unit.
- Dashboard protection IP66.
- Frontal/Back door alarm (visual and acustic).

Product Warranty Protection

- 2 years from the date of installation, after sending the installation report, on the parts (see warranty condition).

Certification



Cabinet MF350.2 2T CO₂

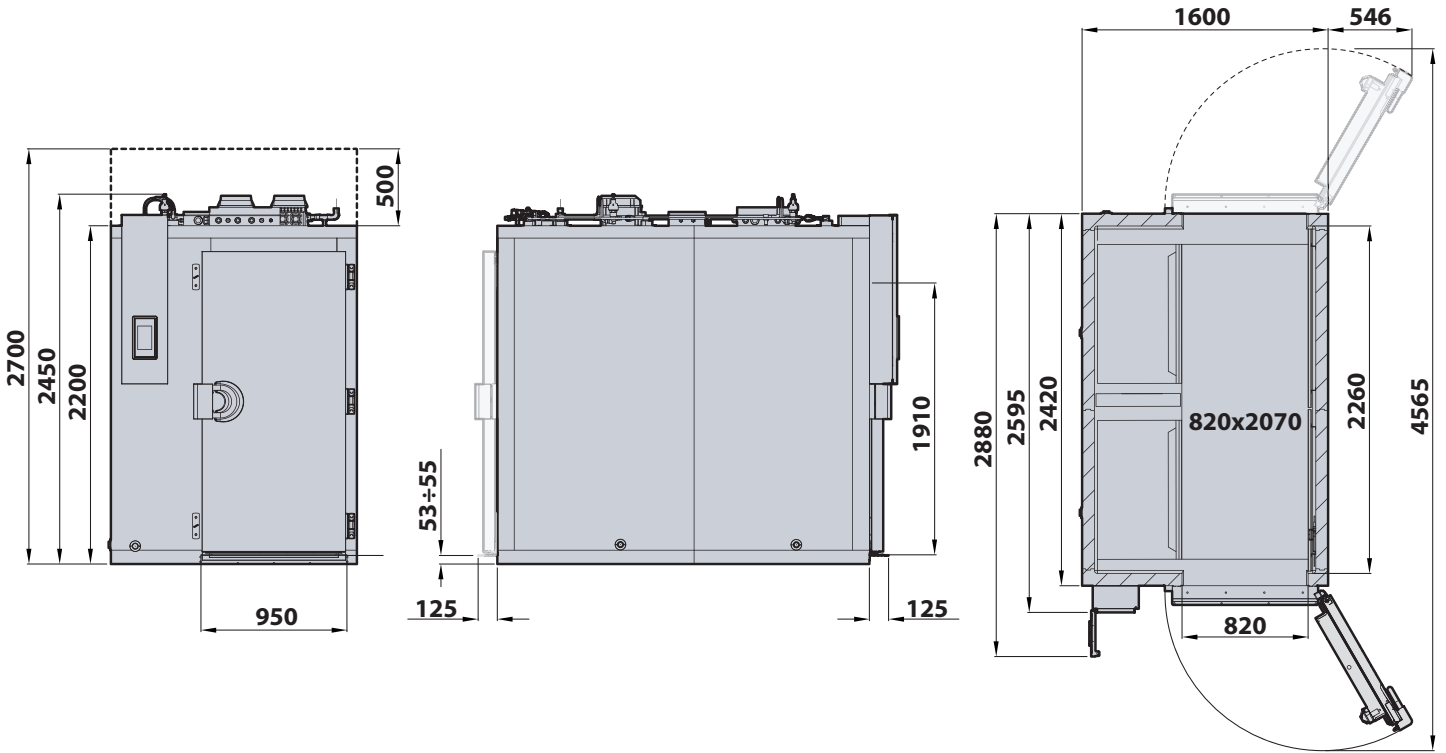

Unit UC 350 CO₂

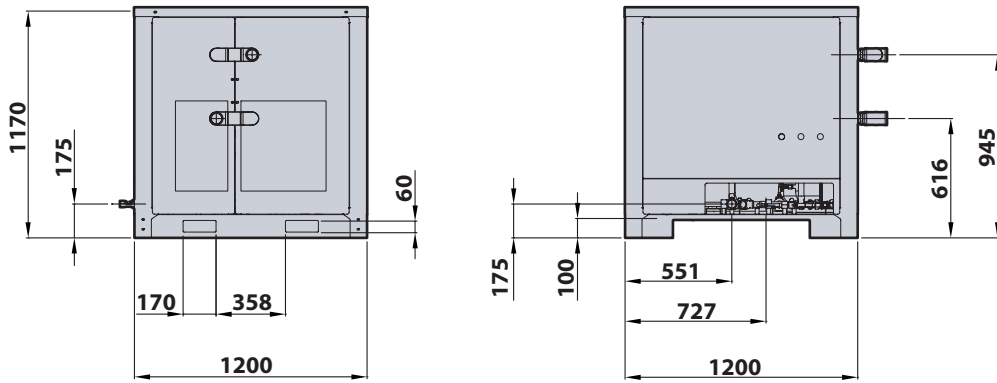

Item No.:

Qty.:

Project:

	Cabinet MF350.2 2T CO ₂	Unit UC 350 CO ₂
Dimensions	L. 1600 mm P. 2595 mm H. 2450 mm	L. 1200 mm P. 1200 mm H. 1170 mm
Pit Dimensions	1610 mm × 2430 mm × 55 mm	-
Weight	800 kg	500 kg

Electric Data		
Electric Supply	400V-3N+PE 50Hz	400V-3N+PE 50Hz
Full Load Amps (FLA)	Plus 30,20 A	38,10 A
Total Rating (FLI)	Plus 20,20 kW	22,00 kW
Start Electrical absorption (LRA)	-	177,00 A
Compressor Noise (1 m)	-	60 dB(A)

Key Refrigeration System Data		
Compressor Rating (HP)	-	20,00
Refrigeration Yield (-10°C/15°C) W	-	45300
Condensing Rating (-10°C/15°C) W	-	54400
Refrigeration Type	-	R744
Refrigeration load (Kg gas)	-	12,0
Maximum Ambient Air Temperature	32 °C	42 °C

INSTALLATION

A detailed installation manual is provided. It must be carefully followed to ensure proper operation and to protect your rights under the warranty. The connection material between the cabinet and the condensing unit must be provided by the installer.

Continuous product development may require changes to specifications without notice.

Irinnox S.p.A.

Headquarter: Via Caduti nei Lager 1, 31015 Conegliano (TV) Italy

Productive Site: Via Mattei, 20 - 31029 - Vittorio Veneto (TV) Italy

Tel. +39 0438 2020 | irinnox@irinnox.com | www.irinnoxprofessional.com

