

Item No.:

Qty.:

Project:

## MF 180.2 CO<sub>2</sub>

### Multi-function Roll-in Blast Chiller and Shock Freezer with R744 - CO<sub>2</sub> natural gas



MultiFresh® MyA CO<sub>2</sub> is the first range Multi-function Roll-in Blast Chiller and Shock Freezer designed for the semi-industrial and industrial sectors capable of performing operating cycles with temperatures from +85°C to -35°C thanks to the Irinox-designed CO<sub>2</sub> condensing unit.

#### Capacity

Trolley Capacity: 2 x GN 1/1

Trolley Capacity: 1 x GN 2/1

Trolley Capacity: 2 x 400x600

Trolley Capacity: 1 x 800x600

#### Yield

Yield for blast chilling cycle (+90°C/+3°C) kg 180

Yield for shock freezing cycle (+90°C/-18°C) kg 180

#### Standard Construction Features

- System consisting of cell and remote water condensing unit with CO<sub>2</sub> gas, built and tested at Irinox.
- IRINOX BALANCE SYSTEM®: perfect dimensions of the main components of the refrigerator (condenser, evaporator, compressor and ventilation).
- Multi-circuit evaporator, designed by Irinox, protected from the corrosive action of food by an electrochemical cataphoresis treatment.
- High-performance three-phase motor evaporator fans, completely made of aluminium and with 5-speed external inverter control.
- Thermostatic electronic valve.
- Maximum cleanliness and hygiene due to rounded comers and components situated in the chamber so that they can be easily accessed and cleaned.
- Sunken floor.
- Drain on the left side (different position on request).
- AISI 304 stainless steel cell internal and external finish.
- 80 mm thick cell panels, insulated with polyurethane foam.
- Evaporator fan door that can be opened for cleaning and maintenance.
- 5-chamber magnetic door seals with dirt-repellent profile.
- Door frame profiles with anti-moisture resistance.
- Ergonomic mechanical closure handle with internal panic button.
- Right-hand opening door, reversible.
- 5-point MultiSensor® probe for perfect product temperature control.
- Automatic switch from manual mode (timed) to automatic mode (with probe); MultiFresh® detects whether or not the probe has been activated automatically.
- Condensing unit designed, assembled and tested at Irinox with the following characteristics: water condensation with a temperature range of +7°C/+12°C, minimum water pressure of 1.5 bar, maximum water pressure of 16 bar, pump head of 50 kPa, equipped with all the control and safety systems.
- Sub-critical working cycle, with maximum working pressure below 57 bar and safety valve at 90 bar.
- Semi-hermetic CO<sub>2</sub> compressor.
- A chiller is required, with cooling capacity greater than 30 kW with +12°C/+7°C In/Out water/brine.
- Unit sent without gas charge

Item No.:

Qty.:

Project:

## Unique Design and Performance Features

- Available in the PLUS version with the following 9 functions: blast chilling, shock freezing, thawing, holding, chocolate, regeneration, pasteurization, proofing and low temperature cooking. Sanigen® included.
- Manual defrosting at the end of the day (not during the work cycles).
- SANIGEN®: 24-hour sanitization (Irinox patented sanitization system; it sanitises every part of the chamber).
- The touch screen also works when you are using kitchen gloves.
- R744 refrigerant gas with GWP 1: it's non-flammable, non-toxic and does not require regular checks pursuant to the F-GAS regulation for high GWP synthetic gases.

## Optional

- Door hinged left.
- Ramp.
- Sous-vide core probe.
- Door stop 100° and 120°.
- Magnetic door stop 100°.
- Pass-thru version.
- Mirror Unit.
- Knocked down.
- Ventilated floor (only with ramp).
- Reinforced floor in stainless steel 20/10.
- Low temperature kit.
- Wifi Mya.
- Ethernet board.
- Freshcloud connection kit (Ethernet card & wi-fi included).
- Anti-vibration feet for condensing unit.
- Dashboard protection IP66.
- Frontal/Back door alarm (visual and acoustic).
- Unit sent without gas charge.

## Product Warranty Protection

- 2 years from the date of installation, after sending the installation report, on the parts (see warranty condition).

## Certification



## Cabinet MF 180.2 CO<sub>2</sub>

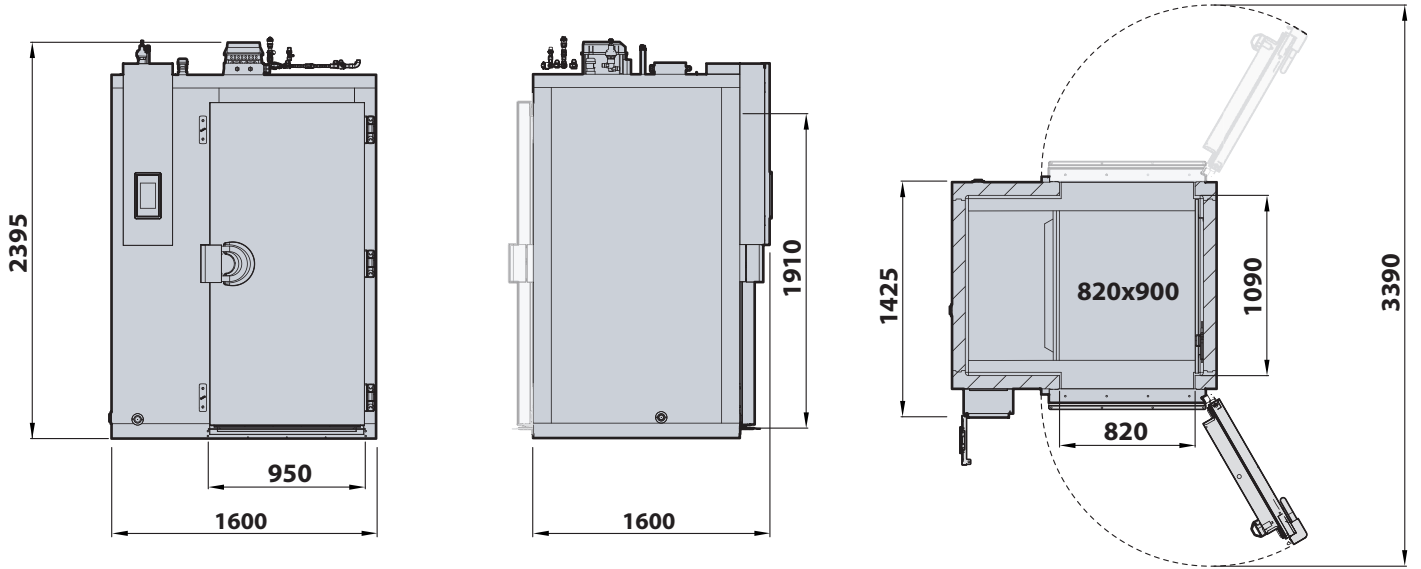

## Unit UC 180 CO<sub>2</sub>

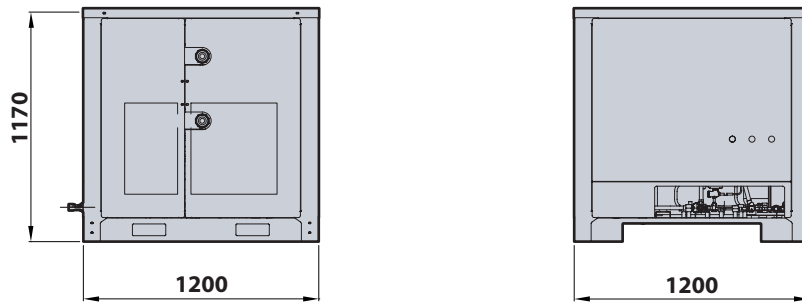

Item No.:

Qty.:

Project:

|                | Cabinet MF 180.2 CO <sub>2</sub> | Unit UC 180 CO <sub>2</sub>      |
|----------------|----------------------------------|----------------------------------|
| Dimensions     | L. 1600 mm P. 1425 mm H. 2395 mm | L. 1200 mm P. 1200 mm H. 1170 mm |
| Pit Dimensions | 1610 mm × 1260 mm × 55 mm        | -                                |
| Weight         | 480 kg                           | 390 kg                           |

| Electric Data / Power Requirements |                 |                 |
|------------------------------------|-----------------|-----------------|
| Electric Supply                    | 400V-3N+PE 50Hz | 400V-3N+PE 50Hz |
| Full Load Amps (FLA)               | Plus 15,30 A    | 22,60 A         |
| Total Rating (FLI)                 | Plus 10,20 kW   | 12,10 kW        |
| Start Electrical absorption (LRA)  | -               | 86,00 A         |
| Compressor Noise (1 m)             | -               | 60 dB(A)        |

| Key Refrigeration System Data    |       |       |
|----------------------------------|-------|-------|
| Compressor Rating (HP)           | -     | 7,50  |
| Refrigeration Yield (-10/15°C) W | -     | 24220 |
| Condensing Rating (-10/15°C) W   | -     | 29210 |
| Refrigeration Type               | -     | R744  |
| Refrigeration PRE-load (kg gas)  | -     | 8,0   |
| Maximum Ambient Air Temperature  | 32 °C | 42 °C |

**INSTALLATION**

A detailed installation manual is provided. It must be carefully followed to ensure proper operation and to protect your rights under the warranty. The connection material between the cabinet and the condensing unit must be provided by the installer.

Continuous product development may require changes to specifications without notice.

**Irinox S.p.A.**

Headquarter: Via Caduti nei Lager 1, 31015 Conegliano (TV) Italy  
 Productive Site: Via Mattei, 20 - 31029 - Vittorio Veneto (TV) Italy  
 Tel. +39 0438 2020 | irinox@irinox.com | www.irinoxprofessional.com

