

Item No.:

Qty.:

Project:

MF 130.2 ST

Roll-in Blast Chiller and Shock Freezer



MultiFresh®: the blast chiller that organizes your production and processes with flexibility 24 hours a day.

MultiFresh® can run cycles of chilling and freezing with temperatures up to -40°C preserving the product consistency, the moisture and nutritional properties.

Multifunction 7" touchscreen display, product specific cycles, wide range of options, customization of all the parameters for each cycle.

Capacity

Trolley capacity: ST Rational SCC 202

ST Convothem ET 20.20

ST Unox CTM 2021

ST MKN FC 20.1/20.2

Yield

Yield for blast chilling cycle ($+90^{\circ}\text{C}/+3^{\circ}\text{C}$) kg 130

Yield for shock freezing cycle ($+90^{\circ}\text{C}/-18^{\circ}\text{C}$) kg 130

Product Warranty Protection

- 2 years from the date of installation, after sending the installation report, on the parts (see warranty condition).

Certification



Standard Construction Features

- Cabinet + Remote air condensing unit.
- IRINOX BALANCE SYSTEM®: the perfect sizing of the main components of the refrigeration system (condenser, evaporator, compressor and fans).
- Maximum cleanliness and hygiene due to rounded corners and components situated in the chamber so that they can be easily accessed and cleaned.
- Mechanical locking device with a low temperature resistant gasket.
- Multisensor® 5 point probe for perfect temperature control.
- Automatic switch from manual mode (timed) to automatic mode (with probe); Multifresh® senses if the probe has been inserted or not.
- Wireless data transfer (HACCP control software).
- Door hinged right.
- With Feet.
- Drain on the left side (different position on request).
- Refrigerant Gas R452A/R404A

Unique Design and Performance Features

- STANDARD VERSION: blast chilling and shock freezing cycles from any temperature, to $+3^{\circ}\text{C}/-18^{\circ}\text{C}$ at the core.
- The touch screen also works when you are using kitchen gloves.
- Manual defrosting at the end of the day (not during the work cycles).

Option and Accessories

- Sous-vide core probe
- Door stop 95° and 120°
- Magnetic door stop 100°
- Knocked down
- Condensing unit on request: Air condensation + extra low dB remote condenser; Air condensation + remote condenser; Pipeline water condensation; Tower water condensation;
- Additional core probe
- SANIGEN®: 24/7 sanification
- Low temperature kit (for air condensation only)
- Wifi Mya
- Ethernet board
- Freshcloud connection kit (Ethernet card & wi-fi included)
- Anti-vibration feet for condensing unit
- Dashboard protection IP66
- Frontal/Back door alarm (visual and acoustic)
- Unit sent without gas charge
- Special Voltage on request

Item No.: _____
 Qty.: _____
 Project: _____

Cabinet

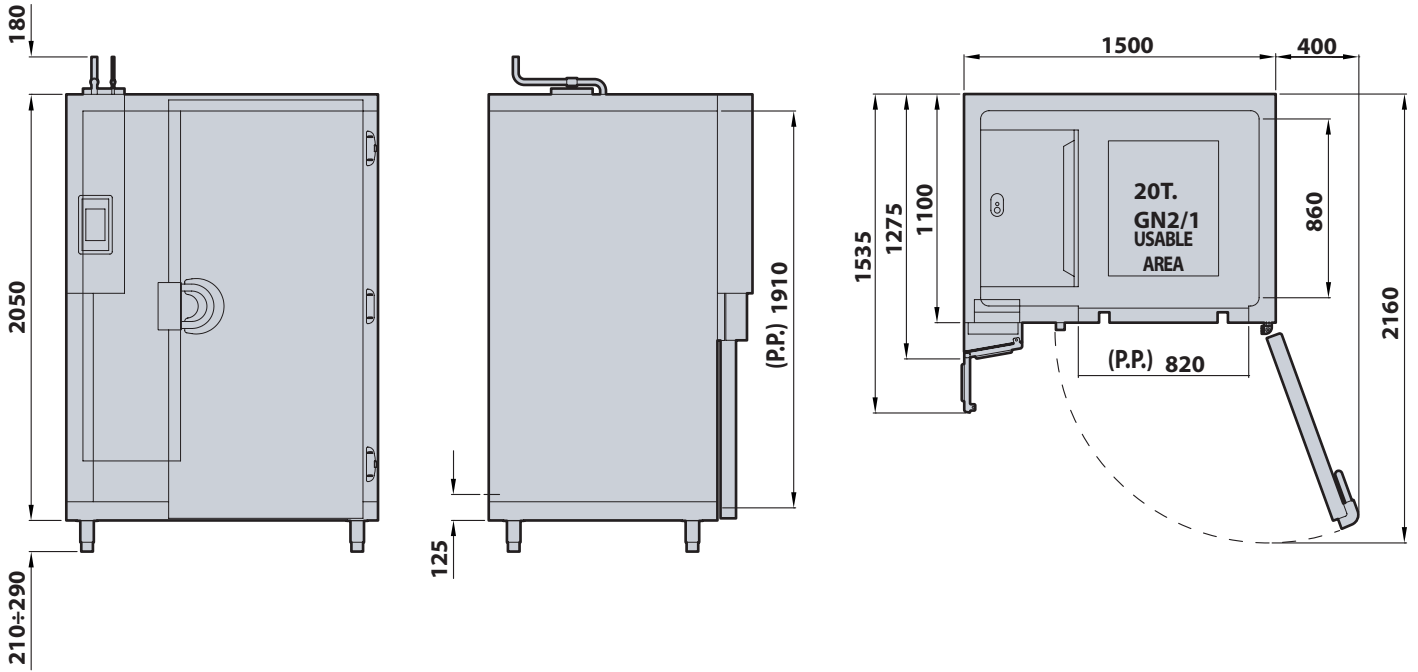

Unit

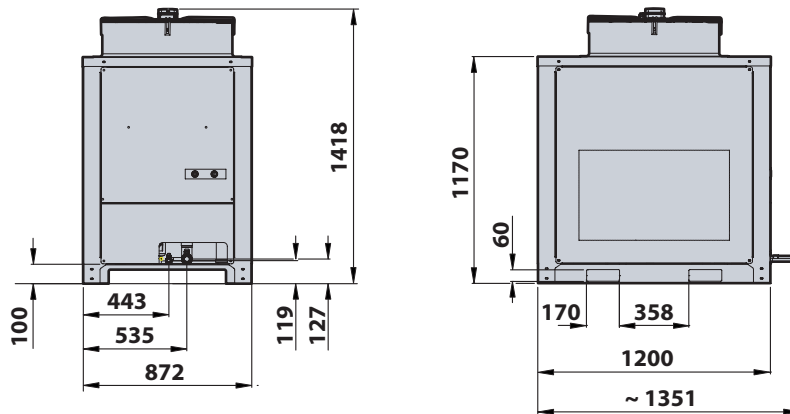

Item No.:

Qty.:

Project:

	Cabinet MF130.2 ST	Unit UC130
Dimensions	L. 1500 mm P. 1275 mm H. 2260 mm	W. 872 mm D. 1200 mm H. 1418 mm
Weight	360 kg	200 kg

Electric Data		
Electric Supply	400V-3N+PE 50Hz	400V-3N+PE 50Hz
Full Load Amps (FLA)	2,50 A	21,50 A
Total Rating (FLI)	1,10 kW	12,00 kW
Start Electrical absorption (RLA)	-	82,40 A
Compressor Noise (1 m)	-	66,1 dB(A)

Key Refrigeration System Data		
Compressor Rating (HP)	-	9
Refrigeration Yield (-10°C/40°C) W	-	17370
Condensing Rating (-10°C/40°C) W	-	24500
Refrigeration Type	-	R452A/R404A
Refrigeration Pre-load (kg gas)	-	11,0
Maximum Ambient Air Temperature	32°C	42°C

INSTALLATION

A detailed installation manual is provided. It must be carefully followed to ensure proper operation and to protect your rights under the warranty.

The connection material between the cabinet and the condensing unit must be provided by the installer.

Continued product development may necessitate specification changes without notice.

Irinox S.p.A.

Headquarter: Via Caduti nei Lager 1, 31015 Conegliano (TV) Italy

Productive Site: Via Mattei, 20 - 31029 - Vittorio Veneto (TV) Italy

Tel. +39 0438 2020 | irinox@irinox.com | www.irinoxprofessional.com