

MultiFresh®

More than Fresh.



MultiFresh®: the multi-function assistant nobody should be without

Organize your production and processes with flexibility 24 hours a day.



BLAST CHILLING

MultiFresh® **blast chills any type of food from +90°C to +3°C**, preserving its consistency, moisture content and nutritional properties.



HOLDING

MultiFresh® holds all food types at the desired positive or negative temperature.



PASTEURIZATION

MultiFresh® **pasteurizes and blast chills (+3°C)** or **pasteurizes and shock freezes (-18°C)** your food products, **increasing their shelf life** and slowing down bacterial proliferation.



SHOCK FREEZING

To preserve shelf life, food must be shock frozen to -18°C at the core. Only MultiFresh® ensures the formation of micro-crystals that do not damage the texture of food.



CHOCOLATE

MultiFresh® meets the needs of confectioners and chocolatiers with **dedicated cycles for chocolate** that maintain its **moisture** so it could be preserved properly over time.



PROOFING

MultiFresh® has **natural proofing cycles** without sudden changes in temperature and with a controlled chamber humidity, with easy programming of the time taken to proof the product perfectly.



THAWING

Use MultiFresh® **to choose the thickness of your food, and the temperature and time** at which it will be thawed and ready for use. Controlling the thawing process means slowing down bacterial proliferation and **keeping the structure of food intact**.



REGENERATION

You can use MultiFresh® to regenerate your dishes by setting the required temperature and the time you want the product to be hot and **ready to serve**. MultiFresh® regeneration cycles go automatically from +3°C or -18°C to regenerate by the desired temperature without damaging the food.



LOW TEMPERATURE COOKING

MultiFresh® **cooks** meats or fish **at low temperatures**, switching automatically to blast chilling, shock freezing or hot holding straight after cooking. The main advantages of low temperature cooking are the enhanced taste and more even cooking.

IRINOX

10:45 | gastronomy

chilling 	freezing
thawing 	holding
regeneration 	low t. cooking
proofing 	pasteurization

MYA: SIMPLY TOUCH

The new 7" touchscreen display makes the MultiFresh® series even easier to use.

MyA

MyA: My Assistant

MULTIFUNCTION DISPLAY

Mya is extremely easy to use. With its simple, intuitive icons you can access MultiFresh®'s numerous functions and manage its cycles.

chilling 	freezing
thawing 	holding
regeneration 	low t. cooking
proofing 	pasteurization
chocolate 	

PRODUCT SPECIFIC CYCLE

For each function, there is a wide choice of cycles specifically designed and tested to maintain the organoleptic characteristics of each product group.

vegetables 	beef 	fish
proofed 	unbaked pie 	soups/sauces
pasta/rice 	double ring mousse 	bread
favorites 	pochè fruit 	pork
chicken 	quiche/pies 	dacquoise

OUTSTANDING CUSTOMIZING OPTIONS

With Mya you can easily edit the parameters of each cycle, including ventilation, duration, temperature, etc., and create the ideal process for each food type.

fase 1 6°C
 3h:30'

 end cycle
 continuous cycle
 +3°C | +65°C | +18°C
 start

★ CREATE YOUR LIST OF FAVORITE CYCLES

Create your list of **favorite** cycles so you can start and manage your most frequently used production processes by the touch of your finger.

REC SAVE YOUR CYCLES

After you have started a cycle you can edit its parameters and save the new settings, creating a customized cycle.

? ON-LINE GUIDE

Find out more about Mya and all the functions of your MultiFresh® unit with our on-line guide.

UNMOLDING

Now you can easily remove food from its mold without damaging it. Mya and MultiFresh® will guide you through each stage of the production process.

⚙️ CHANGE YOUR SETTINGS

Every process is perfectly customizable: for each cycle you can edit the air temperature, core temperature, duration and ventilation.

↻ CONTINUOUS CYCLE

The MultiFresh® continuous cycle runs uninterrupted for more than 8 hours, blast chilling or shock freezing even boiling hot food.

Unbeatable performance

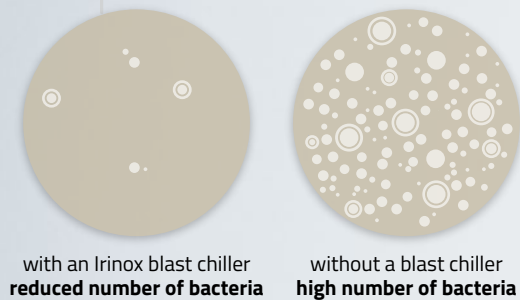
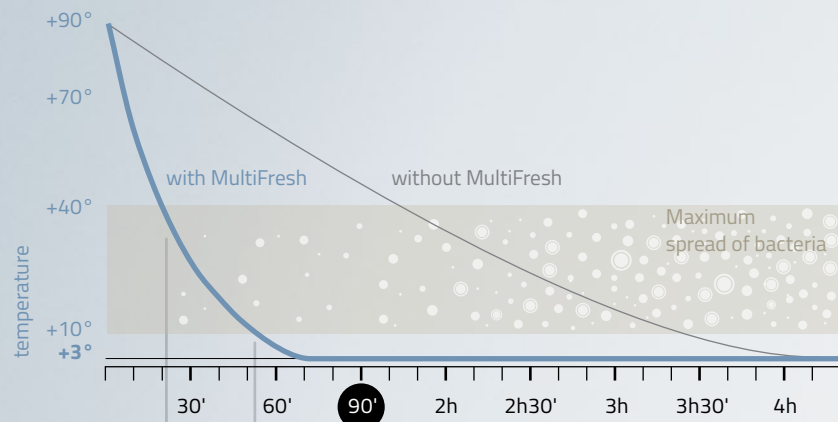

blast chilling +3°C

up to 12 bacterial reproduction cycles without a blast chiller.

Food ages due to evaporation, oxidization and bacterial proliferation. MultiFresh® chills all food to +3°C at the core, rapidly going through the temperature range of +90°C - +70°C. This is very important for product quality, and the temperature of danger zone of +40°C - +10°C considerably increases the product's shelf life.

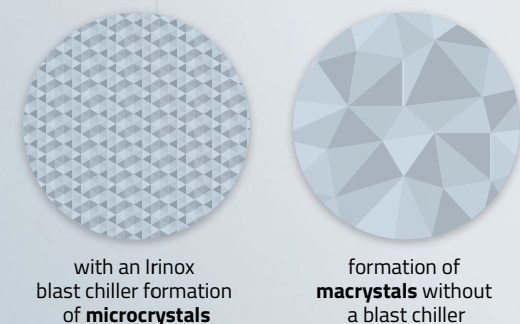
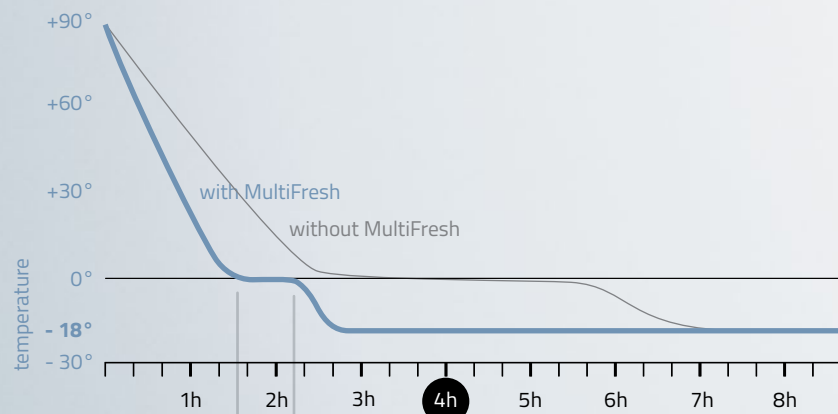

shock freezing -18°C

water macrocrystals are formed without a blast chiller.

Products could be kept for a medium -to-long period only if they are rapidly frozen to **-18°C at the core**. The freezing process of ordinary preservation systems transforms the liquids in food into **macrocrystals** which damage the structure. Irinox guarantees the formation of **microcrystals** that preserve the organoleptic properties of food.

IrinoxBalanceSystem®

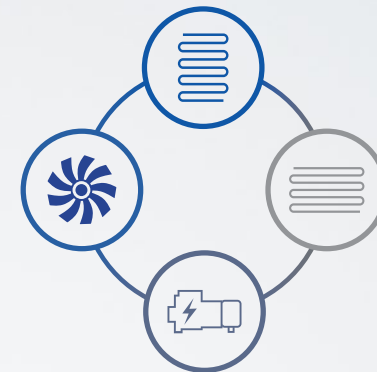

IRINOXBalanceSystem®

IRINOX BALANCE SYSTEM®

Numerous tests and studies performed on cooling curves and the use of sophisticated software have made it possible to determine **the perfect size of the main refrigerator components** (condenser, evaporator, compressor and fans): **IrinoxBalanceSystem®**. The evaporators and condensers involved are built to the drawings and specifications of our engineering office so that our equipment provides unbeatable performance.

The principle on which blast chillers operate consists of removing heat from food in the shortest time possible in order to limit aging. Our blast chillers guarantee the fastest heat removal, also with boiling hot food, without damaging it in any way.

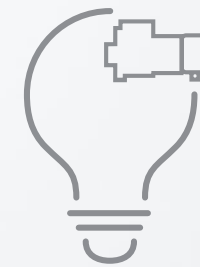

IRINOX EFFICIENCY

MultiFresh® is designed to guarantee **maximum efficiency**: from seeking materials with the lowest environmental impact to achieving the best performance, with the **lowest energy consumption** for the category. With the same care Irinox applies to products for you, Irinox pays attention to **environmental sustainability**. For example, continuous management of electronic on/off for the variable speed fans ensures extremely low energy consumption.

SANIGEN®: 24/7 SANIFICATION

The Irinox patented sanitification system, **sanitizes every part of the chamber**, including the areas that **are difficult to access for cleaning** (e.g. the evaporator, etc.). The system's efficiency, tested by Udine University and **certified by the Ministry of Health**, guarantees **bacteria abatement by 99.5%**. Sanigen® also acts to **eliminate unpleasant odors** that can occur at the end of the work cycle or the working day.



Sanigen®

8 reasons for choosing Irinox



1

Labor cost savings

Save 30% on labor costs, reduce overtime and manage market demand and peak periods in advance.

2 Organize production in advance

Use MultiFresh® to produce a larger amount of food days or weeks in advance. Products can be finished in minutes and on demand.

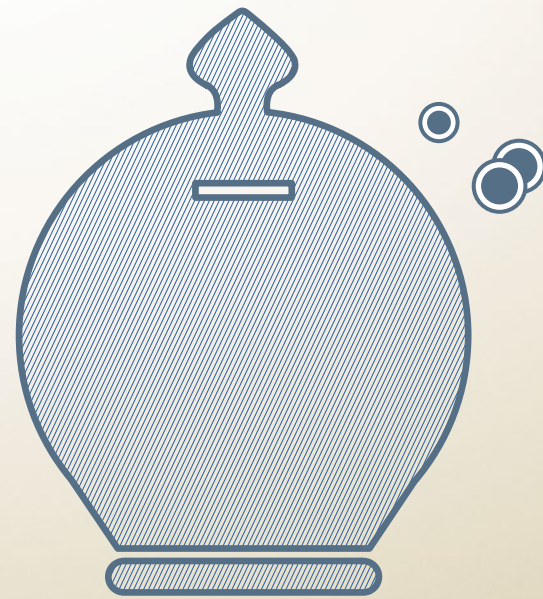

4

Safer food

Careful management of the cold chain maintains freshness over time, ensuring maximum food safety while maintaining of HACCP standards.

3

High product quality

Food which is not properly chilled or frozen loses its consistency, flavor and organoleptic properties. MultiFresh® preserves maximum quality in food.



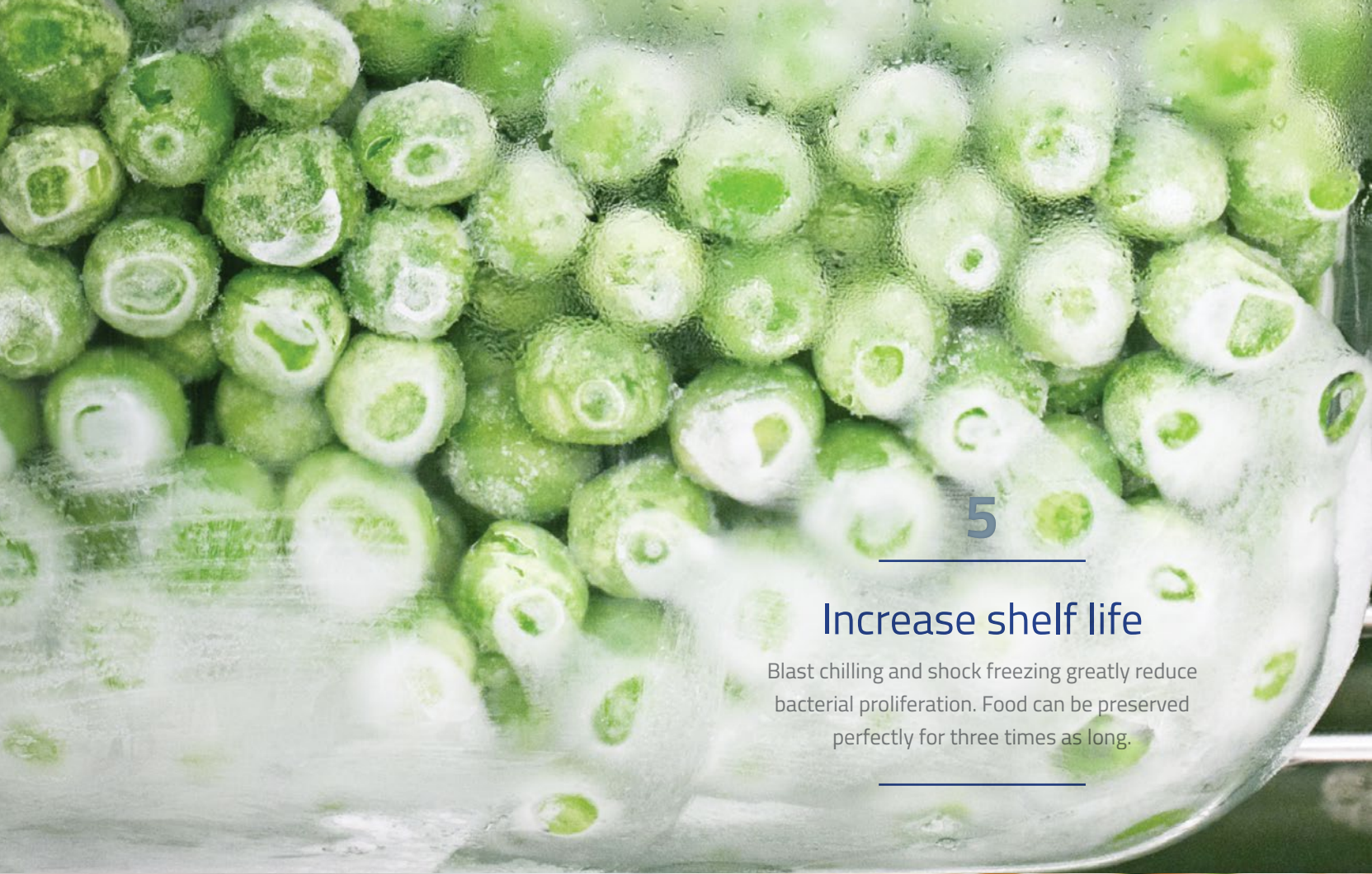

5

Increase shelf life

Blast chilling and shock freezing greatly reduce bacterial proliferation. Food can be preserved perfectly for three times as long.



7

Reduce food cost

Raw materials can be purchased in greater quantities when they are in season and at the best price. Chilling and freezing them with MultiFresh® will maintain the same quality even after many months.



6

Prepare food quickly

Use MultiFresh® to manage your production processes and cut down lead times. Only MultiFresh® makes it possible to blast chill or shock freeze food when it's hot just out of the oven or off the stove.

8

Reduce waste

MultiFresh® drastically reduces waste so that you can plan purchasing and considerably increase freshness in preserved foods and partially finished products.

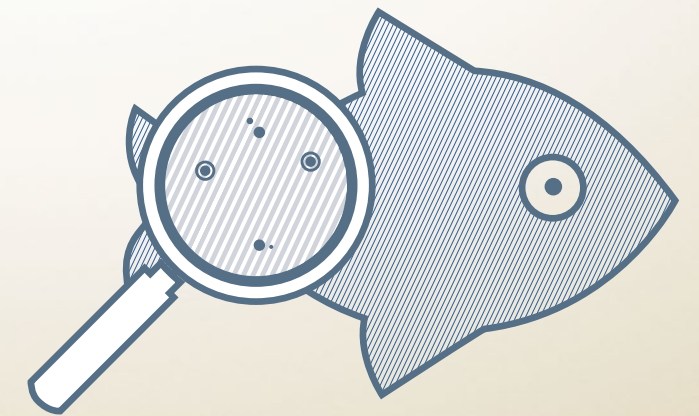



gastronomy

We guarantee freshness
for your dishes every day.

The advantages of Irinox for gastronomy

- > Varied menus
- > Constant quality
- > Better labor management
- > Less waste and more tightly controlled food costs
- > Faster service
- > Hygiene and health assurance



QUALITY IN THE KITCHEN MEANS FRESHNESS

Painstaking attention to details, the search for the best raw materials and excellent preparation—that is what makes food delicious. **The reliability and safety of the technologies used let you serve the original freshness of each ingredient every day.**
Below some applications for gastronomy.



CHILLING

The **vegetable +3°C** cycle blast chills vegetables immediately after cooking, preventing rapid oxidization and loss of their vitamins and mineral salts.



LOW TEMPERATURE COOKING

The main advantages of this type of cooking are increased flavor and aromas, brighter colors and reduced shrinkage. Differently from other low temperature cooking technologies, when after **MultiFresh®** completes the cycle, **it automatically goes on to blast chill (+3°C), shock freeze (-18°C) or hold at +65°C.**



THAWING

Thawing is an extremely delicate step in the treatment of food, as it can compromise the quality and healthiness of your products. With the MultiFresh® thawing cycles you can choose the time you wish to have frozen **products be ready for cooking or further processing.**



FREEZING

The **fish -18°C** cycle is used to shock freeze raw fish to -18°C at the core, as required by HACCP standards (Anisakis free).





AN AID FOR BETTER LABOR JOB MANAGEMENT

Passion, reliability and professionalism are common to all confectioners. With its technology, Irinox helps **increase the quality of your creations and reduce production costs while maintaining a wide assortment of products.** All key to the success of a confectioner. Below some applications for confectionery.



BLAST CHILLING

The **mixes +12°C** cycle is used to cool puff pastry, short pastry and sponge cake to the ideal temperature to **ensure a soft smooth mix.** Puff pastry requires both the mix and butter at a temperature of +12°C, which is ideal for laminating the butter and folding the pastry so that it develops evenly.



CHOCOLATE

MultiFresh® meets the needs of confectioners and chocolatiers with **dedicated chocolate cycles** that maintain its **moisture** so it can be preserved properly over time. For example, the **Chocolate -7°C** cycle rapidly reaches the right temperature for cake decoration.



PROOFING

With its proofing cycles MultiFresh® makes it possible to prove the dough for croissants in an environment where **temperature and humidity are constantly controlled and updated to develop artisan textures.**



SHOCK FREEZING

MultiFresh® also assists you with your baking: it tells you the right moment for **unmoulding**, when the product has reached the **ideal temperature for retail**, and for preservation at +3°C, before going on to shock freezing at -18°C.

confectionery

Take care
of your creations.



The advantages of Irinox for confectionery

- > Constant product quality
- > Vast assortment on display
- > Better organized production
- > Work cycle optimization
- > Products always available
- > You produce even when you're not at work



ice cream

Make your ice cream smoother
and offer your customers
a wider assortment.

The advantages of Irinox for ice cream

- > Increases the shelf life of ice cream
- > Reduces production costs
- > Cuts energy consumption
- > Flavours always available for display
- > Manages peak periods and unexpected demand
- > Reduces overrun losses
- > Plans production
- > Increases the assortment to offer customers (chocolate, mousse, ice cream cakes, semifreddos)



KEEP YOUR ICE CREAM PERFECT FOR LONGER

Ice cream comes out of the batch freezer at a temperature of -7° / -9° C; at this point it still contains 30% water, which is responsible for melting. If the ice cream is placed in the display at -12° C or kept at -18° C without shock freezing, the water expands slowly and forms **macro-crystals** that ruin the structure. In just a few hours the ice cream will lose creaminess, volume and the typical flavor of freshly made ice cream. Below some applications for ice cream.

ICE CREAM RECONSTITUTION

MultiFresh® is the only blast chiller that uses an **ice cream -12° C cycle to quickly make ice cream kept at -18° C ready for retail.**



SHOCK FREEZING

MultiFresh® blast chillers are used to **shock freeze at -18° C or -12° C**; the water in the ice cream is transformed into **micro-crystals** that **maintains the initial quality intact** and do not ruin the structure.



ICE CREAM READY FOR DISPLAY -12° C

MultiFresh® has a cycle dedicated to **ice cream: it shock freezes at -12° C**, rapidly taking it to a temperature of -7° C to -12° C so that it is **immediately ready for retail**. The ice cream preserves overrun and maintains its texture and quality.



MERINGUES/DEHYDATOR

MultiFresh® has low temperature cooking cycles. There is a **special cycle** for ice cream makers with which they can prepare meringues, dehydrate fruit or base for single portions, semifreddos and dacquoise, **allowing you to increase sales and profits.**





NATURAL PROOFING

“To simplify the work of bread-makers”, this is the concept Irinox adopted years ago to assist professionals in this trade with efficient systems designed to guarantee extraordinary quality and optimize production activities. MultiFresh® also means **managing** working hours to your wishes, avoiding night work while observing the traditions and using the recipes that distinguish each bread maker.

Below some applications for bread making.



BLAST CHILLS AND SHOCK FREEZES FRESHLY BAKED BREAD

All baked and pre-baked products can be prepared once a week. MultiFresh® can also be used for shock freezing bread after baking, without dehydrating or damaging its texture. After regeneration bread will be as fresh and tasty as when it was baked.



PRE-BAKED BREAD

MultiFresh® can blast chill and shock freeze all types of pre-baked bread. Give your customers fresh bread every day with the **pre-baked bread** +20°C cycle that blast chills the bread and keeps it at +15°C all day long, ready for retail.



LEAVENED FLATBREAD

Leavened flatbread can be seasoned with sauces, olives, cheese or other ingredients and shock frozen so that it is readily available when needed.



PROOFING

MultiFresh® has controlled proofing cycles, ensuring your bread has rich flavor, the right crust and textures and above all freshness over time.

bread making

Oven warm bread
always to hand.



The advantages of Irinox for bread making

- > Warm bread at any time
- > Vast assortment always available
- > No night work
- > Lower production costs
- > Less waste
- > Increased profits

Care for details is the secret behind Irinox construction quality

MULTIFRESH®: NOISELESS PERFORMANCE

To make the work place even more comfortable MultiFresh® has **extremely quiet** new generation compressors and condensers provided with a fan speed controller that comes on automatically only when necessary. Due to these special functions MultiFresh® has passed the most stringent noise tests.

1 DOUBLE CAPACITY: MULTIRACK®

Irinox patented the MultiRack®, an adjustable tray holder, which allows operators to double the number of trays loaded in each model. It is easy to set the distance between one tray and the next. This allows better air distribution on the product and greater temperature uniformity on all levels. Every baker can choose the type of tray to work with.

2 MULTI-POINT TEMPERATURE PROBE: MULTISENSOR®

The Irinox MultiFresh® is supplied with a **MultiSensor® 5 point probe** for perfect temperature control. **Core temperature readings** provide MultiFresh® software with extremely precise temperature readings which allow **prompt regulation of ventilation, temperature and humidity** in the chamber. The conical shape of the MultiSensor® probe makes it **easy to remove from food** without using heat. The **Irinox patented system of magnetic attachment to the door** makes it easily stored and accessible.

OVERNIGHT DEFROSTING!

MultiFresh® by design defrosts manually at the end of the day. Most other blast chillers activate defrosting automatically during the work cycles. This damages the quality of products due to sudden changes of temperature and slow down the chilling process. MultiFresh® **does not defrost automatically because it is constantly able to remove all the heat from the chamber**, which prevents the formation of ice on the evaporator.

3 EVAPORATORS

Internally sealed evaporators entirely treated by safe anticorrosive cathaphoresis so they last longer.

4 DOOR HANDLE

Designed by Irinox, entirely in stainless steel and free of sharp edges. Sturdy and easy-to-clean, with an ergonomic shape that is easy to grip.

5 INNOVATIVE DOOR CLOSING SYSTEM

The door of the MultiFresh® unit is fitted with a soft closing magnetic closure and high/low temperature resistant gasket designed for easy cleaning.

6 FANS

New generation speed variation fans, with innovative design and materials, provide uniform ventilation throughout the chamber. They incorporate an immediate fan blocking system which prevents cold air from leaving the chamber when the door is opened.

7 EASY CLEANING, ABSOLUTE HYGIENE

Rounded corners guarantee easier cleaning and uniform air circulation. The condensation drip tray collects chamber condensation and is easily removed and emptied at any time. All components such as fans and evaporators, are designed and fitted inside the chamber for easy access and cleaning.

8 OVEN COMPATIBILITY

The structure and size of **MultiFresh®** units are designed to be compatible with the carts and trolleys of major oven manufacturers. The **MultiFresh®** range perfectly integrates into the day-to-day processes of professional kitchens.

WIRELESS DATA TRANSFER

With the wireless data transfer system process all the data can be easily downloaded and saved in the dedicated software (**HACCP control Software**)

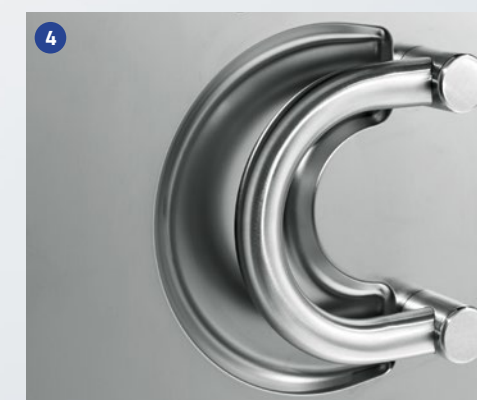
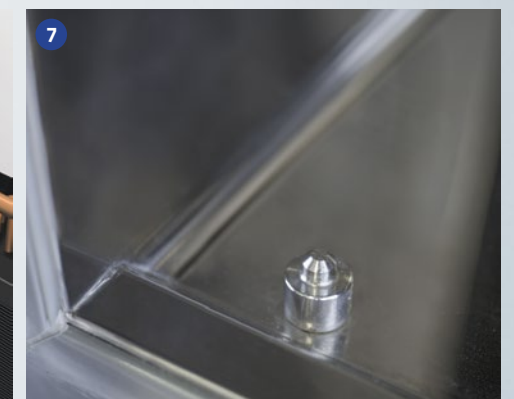
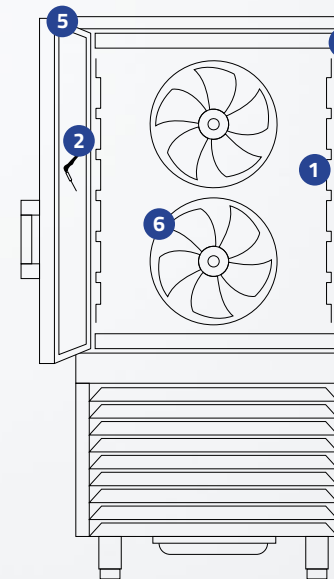
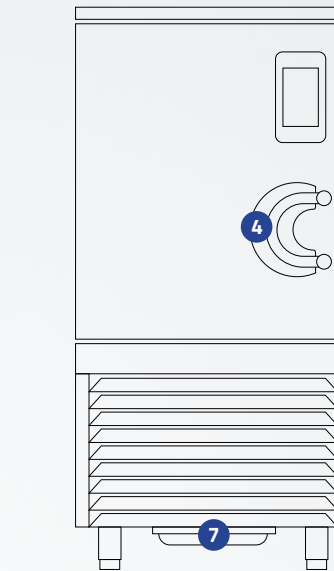

The MultiFresh® range



MF 25.1

Yield per cycle 25 kg
 Tray capacity nr.
 ● 65 mm, 4 (GN1/1 o 600x400 mm)
 ● 40 mm, 5 (GN1/1 o 600x400 mm)
 ● 20 mm, 8 (GN1/1 o 600x400 mm)
 Dimensions 790x771x870 mm
 W 1,2 kW A 6,5 A V 230 V-50 Hz (1N+PE)



MF 45.1

Yield per cycle 45 kg
 Tray capacity nr.
 ● 65 mm, 9 (GN1/1 o 600x400 mm)
 ● 40 mm, 12 (GN1/1 o 600x400 mm)
 ● 20 mm, 18 (GN1/1 o 600x400 mm)
 Dimensions 790x962x1595 mm
 W 3,6 kW A 5,6 A V 400 V-50 Hz (3N+PE)



MF 70.1

Yield per cycle 70 kg
 Tray capacity nr.
 ● 65 mm, 13 (GN1/1 o 600x400 mm)
 ● 40 mm, 18 (GN1/1 o 600x400 mm)
 ● 20 mm, 27 (GN1/1 o 600x400 mm)
 Dimensions 790x962x1970 mm
 W 5,3 kW A 10,8 A V 400 V-50 Hz (3N+PE)



MF 30.2

Yield per cycle 30 kg
 Tray capacity nr.
 ● 65 mm, 4 (GN2/1 o 600x400 mm) - 6 (GN1/1)
 ● 40 mm, 5 (GN2/1 o 600x400 mm) - 8 (GN1/1)
 ● 20 mm, 8 (GN2/1 o 600x400 mm) - 14 (GN1/1)
 Dimensions 870x902x870mm
 W 2 kW A 10 A V 230 V-50Hz (1N+PE)



MF 70.2

Yield per cycle 70 kg
 Tray capacity nr.
 ● 65 mm, 9 (GN2/1 o 600x400 mm) - 16 (GN1/1)
 ● 40 mm, 12 (GN2/1 o 600x400 mm) - 22 (GN1/1)
 ● 20 mm, 18 (GN2/1 o 600x400 mm) - 34 (GN1/1)
 Dimensions 870x1092x1595 mm
 W 5,2 kW A 10,6 A V 400 V-50 Hz (3N+PE)



MF 85.2

Yield per cycle 85 kg
 Tray capacity nr.
 ● 65 mm, 13 (GN2/1 o 600x400 mm) - 26 (GN1/1)
 ● 40 mm, 18 (GN2/1 o 600x400 mm) - 36 (GN1/1)
 ● 20 mm, 27 (GN2/1 o 600x400 mm) - 54 (GN1/1)
 Dimensions 870x1092x1970 mm
 W 6,2 kW A 13,5 A V 400 V-50 Hz (3N+PE)



MF 100.1

Yield per cycle 100 kg
 Capacity
 ● 1x20 (GN1/1 o 600x400 mm)
 Dimensions 1210x1115x2150 mm
 W 1,1 kW A 2,5 A V 400 V-50 Hz (3N+PE)
 Condensing unit 905 A
 W 8,2 kW A 15,2 A V 400 V-50 Hz (3N+PE)



MF 130.2

Yield per cycle 130 kg
 Capacity
 ● 1x20 (GN 2/1 o 600x800 mm)
 ● 1x40 (GN 1/1 o 600x400 mm)
 Dimensions 1500x1275x2150 mm
 W 1,1 kW A 2,5 A V 400 V-50 Hz (3N+PE)
 Condensing unit 915 A
 W 11,4 kW A 22 A V 400 V-50 Hz (3N+PE)

TRAY
 ● tray height
 ● trolleys number

YIELD IN KG
 from +90°C to +3°C / -18°C

DIMENSIONS
 width x depth x height

ELECTRICAL DATA
 W max absorbed power
 A max absorbed current
 V voltage



MF 350.2 2T

Yield per cycle 350 kg
 Capacity
 ● 2x20 (GN 2/1 o 600x800 mm)
 ● 2x40 (GN 1/1 o 600x400 mm)
 Dimensions 1600x2625x2150 mm
 W 4,3 kW A 8,2 A V 400 V-50 Hz (3N+PE)
 Condensing unit 930 A
 W 25,9 kW A 48,8 A V 400 V-50 Hz (3N+PE)



MF 500.2 3T

Yield per cycle 500 kg
 Capacity
 ● 3x20 (GN 2/1 o 600x800 mm)
 ● 3x40 (GN 1/1 o 600x400 mm)
 Dimensions 1600x3825x2150 mm
 W 6,4 kW A 12,2 A V 400 V-50 Hz (3N+PE)
 Condensing unit 935 A
 W 39,9 kW A 68,4 A V 400 V-50 Hz (3N+PE)

TRAY
 ● tray height
 ● trolleys number

YIELD IN KG
 from +90°C to +3°C / -18°C

DIMENSIONS
 width x depth x height

ELECTRICAL DATA
 W max absorbed power
 A max absorbed current
 V voltage

MF 250.2

Yield per cycle 250 kg
 Capacity
 ● 1x20 (GN 2/1 o 600x800 mm)
 ● 1x40 (GN 1/1 o 600x400 mm)
 Dimensions 1600x1425x2150 mm
 W 2,2 kW A 4,2 A V 400 V-50 Hz (3N+PE)
 Condensing unit 925 A
 W 17,2 kW A 35,6 A V 400 V-50 Hz (3N+PE)

MF 300.2

Yield per cycle 300 kg
 Capacity
 ● 1 con dimensione max. L 1050xP 1050 mm
 Dimensions 1880x1625x2150 mm
 W 3,2 kW A 5,4 A V 400 V-50 Hz (3N+PE)
 Condensing unit 928 A
 W 19,9 kW A 42,2 A V 400 V-50 Hz (3N+PE)

MF 500.2 2T

Yield per cycle 500 kg
 Capacity
 ● 2x20 (GN 2/1 o 600x800 mm)
 ● 2x40 (GN 1/1 o 600x400 mm)
 Dimensions 1600x2625x2150 mm
 W 4,3 kW A 8,2 A V 400 V-50 Hz (3N+PE)
 Condensing unit 935 A
 W 39,9 kW A 68,4 A V 400 V-50 Hz (3N+PE)

MF 750.2 3T

Yield per cycle 750 kg
 Capacity
 ● 3x20 (GN 2/1 o 600x800 mm)
 ● 3x40 (GN 1/1 o 600x400 mm)
 Dimensions 1600x3825x2150 mm
 W 6,4 kW A 12,2 A V 400 V-50 Hz (3N+PE)
 Condensing unit 950 A
 W 59,5 kW A 105,6 A V 400 V-50 Hz (3N+PE)

IRINOX

via Madonna di Loreto, 6/B
31020 Corbanese di Tarzo (TV) - Italy
P. +39 0438 5844
F. +39 0438 5843
irinox@irinox.com
www.irinoxprofessional.com

Irinox in the world:

IRINOX D/A/CH/Lux

Mobil: +49 (0) 172 759 77 91
P. +39 0438 584 222
F. +39 0438 584 120
irinox.deutsch@irinox.com
www.irinoxprofessional.com

IRINOX USA

50 Oliver Street, Suite WI
North Easton | MA 02356
P. +1 508 230-5818
F. +1 508 230-5819
info@irinoxusa.com
www.irinoxusa.com