

Item No.:

Qty.:

Project:

EF NEXT M

The essential, easy and safe blast chiller



The Irinox rapid blast chiller cools quickly to +3°C and deep freezes food at -18°C at the core, even hot ones just removed from the oven. The operating principle of a blast chiller is to extract the heat from the food in the shortest possible time. EasyFresh Next guarantees ultra-rapid cooling and freezing and preserves the fragrance, consistency, colours and all food nutritional properties, fixing its quality and freshness longer over time.

Yield

Rapid blast chilling cycle capacity (+90°C/+3°C) kg 38

Rapid freezing cycle capacity (+90°C/-18°C) kg 35

Tests carried out in compliance with the Irinox procedure using 5-cm thick beef

Capacity

Number of trays: 18 x GN1/1 o 600x400 (H= 20 mm)

Number of trays: 12 x GN1/1 o 600x400 (H= 40 mm)

Number of trays: 9 x GN1/1 o 600x400 (H= 65 mm)

Optional

- Door opening on the right with hinges on the right.
- Adjustable lowered feet H 80 - 115 mm.
- 4 wheels, 2 of which with brake.
- Sanigen® (Irinox patented sanitization system).
- R404A refrigerant gas.
- Additional pair of guides GN1/1 and 600x400 mm
- Special voltages on request
- Sousvide probe 1 point.
- Unit sent without gas charge.

Product warranty

- 2 years from the date of installation, after sending the installation report, on the parts (see warranty condition)

Operation

- EasyFresh Next's cooling cycles lower to +3°C the core temperature of the food, introduced at any temperature, even as soon as it is out of the oven, and quickly cross the band of maximum bacterial proliferation, the cause of their natural ageing.
- EasyFresh Next's has two cycles dedicated to cooling. DELICATE +3°C: suitable for the most delicate products such as mousses, creams, fish, rice, vegetables and more generally food of reduced thickness and with a high water content. STRONG + 3°C: ideal for fat, very dense, large-sized or packaged products, such as meats, soups, sauces.
- EasyFresh Next's freezing cycles transform the water contained in food into microcrystals that preserve its structure and quality for longer. EasyFresh Next has 2 freezing cycles. DELICATE -18°C, works in two phases, one at positive temperature and the other negative, and is recommended for leavened bakery products or for bread; STRONG -18°C: quickly freezes medium-large products up to -18°C in the core, with an air temperature reaching -35°C. Also ideal for fixing the structure of ice cream.
- Automatic recognition of manual work mode (timed) or automatic mode (with probe).

Standard construction details

- Door opening on the left with hinges on the left.
- Patented concealed hinges.
- Full height door with double bevelled side edges.
- Door opening up to 150°.
- Magnetic and slow closing of the door.
- Equipped with 5-chamber gasket designed for high and low temperatures.
- Magnetic flat surface (400x150 mm) to fix the core probe.
- Core probe with one detection point with quick screw connector, anti-corrosion, watertight IP67.
- Easy removal and cleaning of the condenser filter thanks to the tilting grill.
- Ergonomic and robust handle made of steel.
- 4.3' resistive colour touch-screen display with intuitive icons and controls; in just 3 steps it allows you to start the cooling or freezing cycles.
- IRINOX BALANCE SYSTEM®: is the design system created by Irinox, applied to the whole range of blast chillers. Compressor, condenser, evaporator and ventilation are balanced to interact perfectly with each other. The goal of "Irinox Balance System" is to always guarantee the freshness and original quality of the product.
 - Condenser: designed by Irinox, it guarantees the performance declared in Climate Class 4.
 - Evaporator: designed by Irinox, protected from the corrosive action of food with a cataphoresis treatment.
 - Ventilation: use of high efficiency one-speed fans.
 - Compressor: high efficiency and performance.
- 304 stainless steel internal and external material.
- Built-in air condensation.
- R452A refrigerant gas.
- MultiRack®, the patented adjustable tray holder that improves air circulation inside the blast chiller.
- 10 pairs of guides included.
- Maximum cleanliness and hygiene thanks to the rounded corners and components in the chamber.
- USB port for HACCP data download.

EF NEXT M

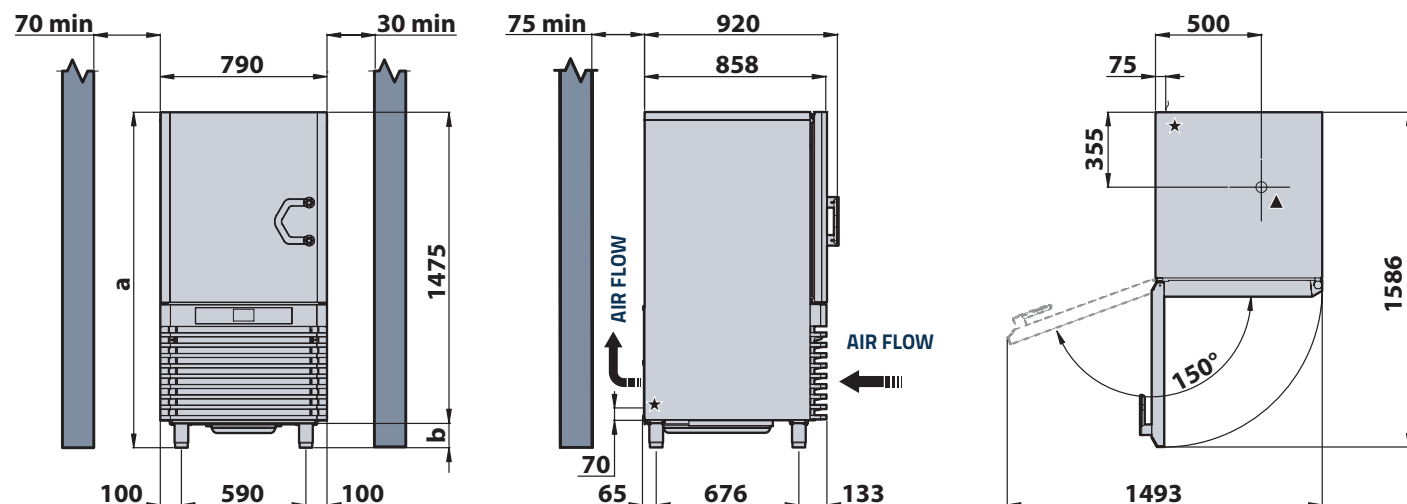

HEIGHT

		a	b
Standard feet	mm	1590 ÷ 1640	115 ÷ 165
Lowered feet option	mm	1555 ÷ 1590	80 ÷ 115
Castors option	mm	1630	155

Measurement in millimetres

- ★ Main power cable
- ▲ Drain pipe (corrugated flexible hose $\varnothing 32$ mm)

TECHNICAL SPECIFICATIONS

		400V-3N+PE 50Hz	400V-3N+PE 60Hz	230-3N 60Hz	200V-3 50/60Hz
Power supply	-	400V-3N+PE 50Hz	400V-3N+PE 60Hz	230-3N 60Hz	200V-3 50/60Hz
Maximum operating power consumption	W	2700	2700	3000	3000 / 3600
Power consumption	A	4,4	4,4	8,9	12.3 / 12.5
Main power cable	mm ²	5G2.5	5G2.5	4G2.5	4G1.5
Compressor rating	HP	1,5	1,5	1,5	2,0
Cooling power (-10°C/+40°C)	W	3987	4805	4805	4105 / 4750
Condensing power (-10°C/+40°C)	W	5871	7008	7008	6375 / 7720
Minimum air exchange	m ³ /h	3100	3700	3700	3000 / 3300
Coolant type	-	R404a/R452a	R404a/R452a	R404a/R452a	R404a
Nominal coolant quantity	kg	1,7	1,7	1,7	2,0
Climate class	-	4 (32°C)	4 (32°C)	4 (32°C)	4 (32°C)
Dimension (width x depth)	mm	790 x 920			
Internal cell dimension (width x depth x height)	mm	650 x 420 x 795			
Cabinet weight	kg	160			
Noise (5M)	dB(A)	77	77	-	77 / 77

ENERGY CONSUMPTION ACCORDING TO EN 17032

Model		EF_NEXT_M (400V-3N+PE 50Hz)	
Type of product		Blast chiller / Blast freezer	
Chilled full load capacity	kg	38	
Frozen full load capacity	kg	35	
Energy consumption Blast chilling cycle (STRONG +3 °C)	kWh/kg	0,0870	
Energy consumption Blast freezing cycle (STRONG -18 °C)	kWh/kg	0,1660	
Blast chilling cycle from/to +65 °C / +10 °C	min	93	
Blast freezing cycle from/to +65 °C / -18 °C	min	232	

INSTALLATION

The blast chiller must be installed by following and complying with the contents of the specific installation manual

The content of the manual must be carefully followed to ensure correct operation and to protect the rights of the user based on the warranty.

Continuous product development may require changes to specifications without notice.

Irinox SpA

Headquarter: Via Caduti nei Lager 1 - 31015- Conegliano (TV) Italy

Productive Site: Via Mattei, 20 - 31029 - Vittorio Veneto (TV) Italy

Tel. +39 0438 2020 | irinox@irinox.com | www.irinoxprofessional.com