



HMC Series Installation Guide

Your Industrial Control Solutions Source

www.maplesystems.com



Introduction

Thank you for purchasing a Maple Systems HMC. The HMC Series are HMCs (Human Machine Controllers) configured using the MAPware-7000 software ([purchased separately](#)).

This booklet describes the steps necessary for installing the HMC Series.

For information on programming and configuring the HMC, please refer to the **MAPware7000 Programming Manual** included with the MAPware-7000 software or available for download. For additional information, please refer to the Support Center section on our website, www.maplesystems.com. The Support Center provides links to manuals, FAQs, technical notes, training videos, sample projects, controller information sheets, and controller cables.

Static Awareness

Do NOT remove the rear cover of your HMC Series product – doing so will void your warranty. When the rear cover is removed the circuitry inside is exposed to possible damage by electrostatic discharge during handling. Minimize the possibility of electrostatic discharge by:

- Discharging personal static by grounding yourself prior to handling the HMC.
- Handling the HMC at a static-free grounded workstation.
- Connecting the frame ground (\perp) connector of the HMC to a clean earth ground.
- Placing the HMC in an antistatic bag during transport.

Unpacking the Unit

Carefully unpack the HMC. Please read any instructions or cautions that appear on the shipping container. Check all material in the container against the packing list. Maple Systems, Inc. will not accept responsibility for shortages against the packing list unless notified within 30 days. The equipment has passed all Quality Assurance testing before shipment. Examine the equipment carefully; if any shipping damage is evident, notify the carrier immediately. Maple Systems is not responsible for claim negotiations with the carrier. Save the shipping container and packing material in case the equipment needs to be stored, returned to Maple Systems, or transported for any reason.

Packing List
HMC Unit
Power Connector
Mounting Clamps
HMC Series Quick Start Guide

Table of Contents

Introduction	1
Warranty.....	3
HMC Models.....	3
What is a HMC Series?	3
Models Available	4
Installation.....	6
CE Compliance	6
Environmental Considerations	6
NEMA Rating	6
Safety Precautions.....	6
Location Considerations.....	7
Control Panel Design Guidelines	7
Panel Preparation	7
Mounting the HMC in an Enclosure	8
Installing the I/O Expansion Modules.....	15
Control Panel Grounding	17
Connect HMC Chassis Ground to Control Panel.....	17
Power Supply Selection	18
Cable Routing and Noise Immunity.....	18
Connect the HMC to Power	18
Communication Ports.....	20
Serial Ports	20
Ethernet port.....	22
USB Client (Slave) port	22
USB Host port	3
Micro SD Card port.....	3
Configuration Wiring.....	3
Connecting to Peripherals	2
I/O Expansion Modules.....	2
PLCs/Controllers.....	2
Connecting to a PLC	2
Serial Printer.....	26
USB Flash Drive	27
Uploading/Downloading Projects via Flash.....	27
Downloading a HMC project from a Flash Drive.....	30

Warranty

Maple Systems warrants each HMC product (not including I/O expansion modules) to be free from electrical and mechanical defects in materials and workmanship for a period of one year from the date of shipment. Maple Systems warrants each HMC I/O expansion module product to be free from electrical and mechanical defects in materials and workmanship for a period of ninety days from the date of shipment. This warranty does not apply to defects in the Products caused by abuse, misuse, accident, casualty, alteration, negligence, repair not authorized by Maple Systems, use on current or voltages other than specified by Maple Systems, or application or installation not in accordance with published instruction manuals. This warranty is in lieu of any other warranty either expressed or implied.

Maple Systems liability is limited to the repair or replacement of the Product only, and not costs of installation, removal, or damage to user's property or other liabilities. If Maple Systems is unable to repair or replace a nonconforming Product, it may offer a refund of the amount paid to Maple Systems for such Product in full satisfaction of its warranty obligation. Maximum liability of Maple Systems is the cost of the Product.

Information furnished by Maple Systems, Inc., is believed to be accurate and reliable. However, no responsibility is assumed by Maple Systems for the use of this information or for any infringements of patents or other rights of third parties which may result from its use. No license is granted by implication, or otherwise, under any patent or patent rights of Maple Systems, Inc. Maple Systems retains the right to revise or change its products and documentation at any time without notice.

HMC Models

What is a HMC Series?







The HMC Series are combination HMI (human machine interface) and PLC (programmable logic controller) in one unit. The HMC can be used as a stand-alone unit capable of connecting directly to inputs and outputs (both digital and analog sources) through the use of optional expansion I/O modules. These I/O modules are controlled using industry standard ladder logic instructions built-in to the programming software. The HMC (human machine controller) also has a display and keypad/touchscreen to allow a plant floor operator visual feedback as well as direct input to the industrial automation system.

In addition, the HMC can connect to external PLCs or other controllers via a serial connection. This flexibility provides access to most major manufacturer PLCs such as Rockwell Automation (Allen Bradley), Schneider Electric (Modicon Modbus), Siemens, GE Fanuc, Omron and many others.

Most important of all, the HMC Series is specifically designed for harsh industrial environments. Every unit is rated for CE (European Noise Immunity/Emissions standards), NEMA 4 rating, and UL listed for installations requiring a Class I Division 2 product.

Models Available

Below are the models currently available from Maple Systems:

Model	Display Size	Description
HMC7030A-L 	3" LCD, 128x64 pixels, with tri-color (Red, Green, Blue) display	18 membrane-style keys (no touchscreen), 1 serial port, 1 USB slave port, 12 digital inputs and 8 digital outputs built-in, no expansion slots
HMC7030A-M 	3" LCD, 128x64 pixels, with tri-color (Red, Green, Blue) display	18 membrane-style keys (no touchscreen), 1 serial port, 1 USB slave port, no local inputs/outputs, three expansion slots
HMC7043A-M 	4.3" TFT 65K color display, 480x272 pixels, LED backlight	touchscreen, Ethernet, 2 serial ports, 1 USB slave port, 1 USB host port, no local inputs/outputs, three expansion slots
HMC7070A-M 	7" TFT 65K color display, 800x480 pixels, LED backlight	touchscreen, Ethernet, 2 serial ports, 1 USB slave port, 1 USB host port, no local inputs/outputs, five expansion slots
HMC2043A-M/HMC4043A-M/HMC3043A-M 	4.3" TFT 65K color display, 480x272 pixels, LED backlight	touchscreen, Ethernet, 1 serial ports, 1 USB slave port, 1 USB host port, no local inputs/outputs, one expansion slot
HMC2070A-M/HMC4070A-M/HMC3070A-M 	7" TFT 65K color display, 800x480 pixels, LED backlight	touchscreen, Ethernet, 2 serial ports, 1 USB slave port, 1 USB host port, no local inputs/outputs, three expansion slots
HMC2101A-M/HMC4101A-M 	10.1" TFT 65K color display, 1024x600 pixels, LED backlight	touchscreen, Ethernet, 2 serial ports, 1 USB slave port, 1 USB host port, no local inputs/outputs, five expansion slots

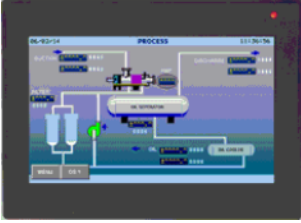
HMC3102A-M	10.2" TFT 65K color display, 800x480 pixels, LED backlight	touchscreen, Ethernet, 2 serial ports, 1 USB slave port, 1 USB host port, no local inputs/outputs, five expansion slots
		

I/O expansion modules can be connected to the units. Note: the HMC7000 Series models use the HMC7 Series I/O expansion modules while the HMC3000, HMC2000, and HMC4000 Series models use the HMC3 Series I/O expansion modules. See *The I/O Module Guide for the HMC7000 Series* or *The I/O Module Guide for the HMC3000 Series* for more information.

Installation

CE Compliance

The HMC Series Graphic HMCs have been tested to conform to European CE requirements, which meet or exceed the noise emissions and immunity requirements as set forth in the EN55022 (Emissions) and EN55024 (Immunity) standards. The products are designed to withstand electrical noise in harsh industrial environments. They also conform to requirements that limit electrical emissions. However, this does not guarantee that the products will be totally immune from possible malfunction in cases where severe electrical noise occurs. Therefore, we strongly recommend that you follow the guidelines outlined in this guide for proper wire routing and grounding to insure the proper operation of your graphic HMC.

Environmental Considerations

The HMC Series is designed to operate in temperatures from 0° to 50°C (32° to 122°F). It is intended for indoor installations and may not be suitable for use in certain outdoor applications. Make sure that the unit is installed correctly and that the operating limits are adhered to (see Specifications from Maple Systems website). Avoid installing the HMC Series in environments with severe mechanical vibration or shocks. Do not install the HMC in enclosures with rapid temperature variations or high humidity. Either will cause condensation of water inside the device and eventual damage to the HMC. Highly humid areas are also to be avoided. High humidity causes condensation of water in the unit.

Do not operate the HMC Series in areas subject to explosion hazards due to flammable gases, vapors or dusts.

NEMA Rating

The HMC Series is rated for NEMA 4/12 (indoor) or IP66 installations. This means that when the HMC is properly mounted to a NEMA 4 panel or other NEMA 4 rated enclosure, the front enclosure of the HMC will provide protection to the inside of the panel from splashing water, wind-blown dust, rain, or hose-directed water. The HMC must be installed according to the instructions in this manual to be properly sealed.

Safety Precautions

Please observe the following precautions when installing the HMC. Failure to comply with these restrictions could result in loss of life, serious personal injury, or equipment damage.



Warning: Do not operate the HMC in areas subject to explosion due to flammable gases, vapors, or dusts.



Warning: Do not connect the HMC to an AC power source. You will cause permanent damage to the HMC.



Warning: Do not attempt to use a DC power supply that does not meet HMC power requirements. You may cause malfunction or permanent damage to the HMC.



Warning: Do not power the HMC with a DC power supply used for inductive loads or for input circuitry to the programmable logic controller. Severe voltage spikes caused by these devices may damage the HMC.

Location Considerations

Care should be taken when locating equipment behind the HMC to ensure that AC power wiring, PLC output modules, contactors, starters, relay and any other source of electrical interference are located away from the HMC. Particular care should be taken to locate variable speed drives and switching power supplies away from the HMC.

Control Panel Design Guidelines

Panel Preparation

A metal panel or mounting surface is required. The minimum thickness should be 15 gauge (0.059 in/3.3 mm) if cold-rolled steel or hardened steel is used. Use 10 gauge (0.101 in/2.6 mm) if aluminum alloy (6061-T6 preferred) is used. Thinner panels or surfaces may bow between the mounting clamps and not form a seal with the gasket. Make sure all supplied mounting clamps are used and that the panel does not flex or bow more than 0.010 in. to ensure a proper seal. Maximum thickness should be no more than 0.26" or 6.5mm.

The HMC should be mounted into a panel with a depth of at least 4 in. (105 mm). Allow a clearance of at least 1 in. (25 mm) on each side for mounting hardware. Consider proper clearance for cable connections when mounting.

NOTE: Cutout dimensions for each particular HMC model are readily available for download from the Support Center-Dimensional Drawings section of the Maple Systems website

Warning: The HMC requires a stiff, flat, smooth mounting surface free of blemishes, scratches, or pits in order that the gasket seal properly to NEMA 4. If the panel or mounting surface is not uniform, thick, flat, stiff, or smooth enough, then a sealant such as silicone may be required.

NOTE: Clean and deburr the panel cutout before the HMC is installed

Pay careful attention to the placement of system components and associated cable routing. These items can significantly enhance the performance and integrity of your control application.

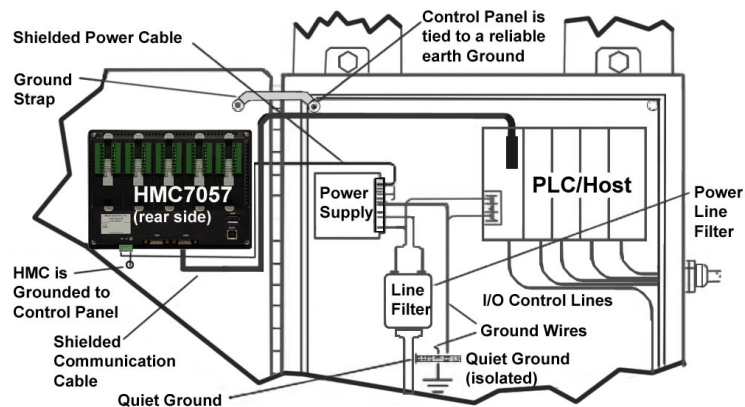
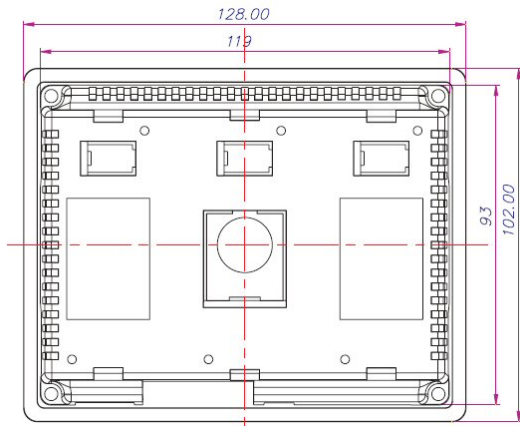

Figure 1: Typical Panel Layout

Mounting the HMC in an Enclosure

Panel Cutout and Mounting for the HMC7030A-M and HMC7035A-M models:

Below is the panel cutout (4.69"x3.67" [119x93 mm]) and mounting dimensions for all 3.5" and 2.7" LCD models:



NOTE: the maximum panel thickness should be at least 0.26" [6.5mm] (tolerance ± 0.0004 " [± 0.01 mm])

► Procedure to mount the unit:

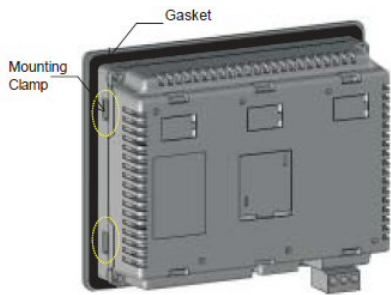

Figure 1

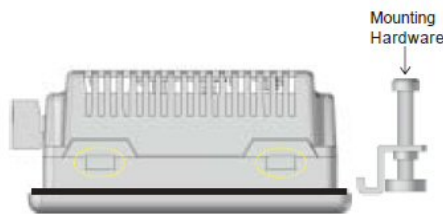

Figure 2



Figure 3



Figure 4

- Make a cutout in the panel to the required size.
- Place the unit into the panel. The sealing gasket is placed directly behind the HMC bezel. (Note: use a sealing adhesive in installations in which the panel surface is rough or uneven).
- On each HMC, there are four mounting slots. Four mounting clamps (with clamp, bolt, and cap nut) are included with each HMC. Insert each clamp into the mounting slots. Hold the unit in place, while you tighten the mounting bolts evenly (to about 0.5 lb-ft of torque).

Caution: Do not over-tighten the screws beyond snugness or you may damage the housing or warp the overlay.

Panel Cutout and Mounting for the HMC7043A-M models:

Below is the panel cutout (4.69"x3.67" [119x93 mm]) and mounting dimensions for the 4.3" LCD models:

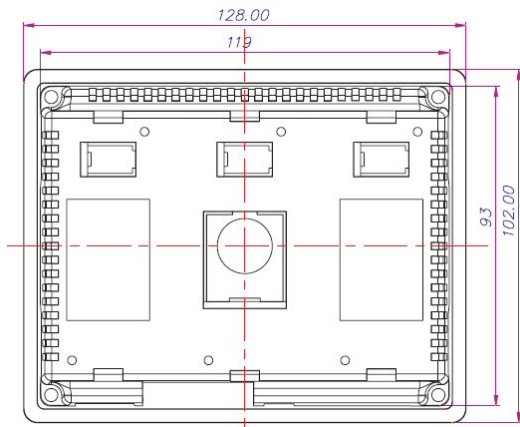

NOTE: the maximum panel thickness should be at least 0.26" [6.5mm] (tolerance ± 0.0004 " [± 0.01 mm])

► Procedure to mount the unit:

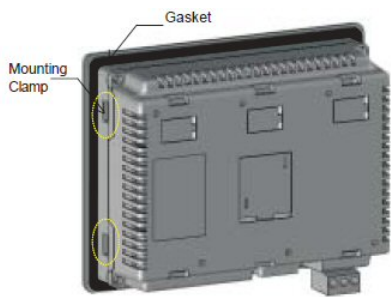

Figure 1

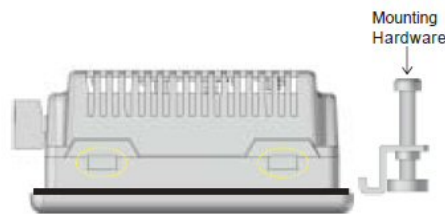

Figure 2



Figure 3



Figure 4

- Make a cutout in the panel to the required size.
- Place the unit into the panel. The sealing gasket is placed directly behind the HMC bezel. (Note: use a sealing adhesive in installations in which the panel surface is rough or uneven).
- On each HMC, there are four mounting slots. Four mounting clamps (with clamp, bolt, and cap nut) are included with each HMC. Insert each clamp into the mounting slots. Hold the unit in place, while you tighten the mounting bolts evenly (to about 0.5 lb-ft of torque).

Caution: Do not over-tighten the screws beyond snugness or you may damage the housing or warp the overlay.

Panel Cutout and Mounting for the HMC2043A-M, HMC3043A-M, and HMC4043A-M models:

Below is the panel cutout (4.33"x3.11" [110x79 mm]) and mounting dimensions for the 4.3" LCD models:

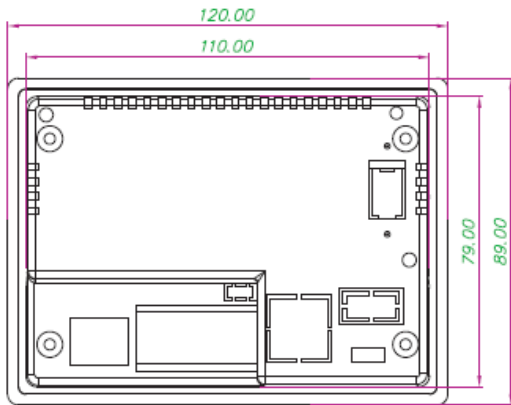

NOTE: the maximum panel thickness should be at least 0.24" [6mm] (tolerance ± 0.0008 " [± 0.02 mm])

► Procedure to mount the unit:



Figure 1



Figure 2



Figure 3



Figure 4

- Make a cutout in the panel to the required size.
- Place the unit into the panel. The sealing gasket is placed directly behind the HMC bezel. (Note: use a sealing adhesive in installations in which the panel surface is rough or uneven).
- On each HMC, there are four mounting slots. Four mounting clamps (with clamp, bolt, and cap nut) are included with each HMC. Insert each clamp into the mounting slots. Hold the unit in place, while you tighten the mounting bolts evenly (to about 0.3 lb-ft of torque).

Caution: Do not over-tighten the screws beyond snugness or you may damage the housing or warp the overlay.

Panel Cutout and Mounting for the HMC7057A-M models:

Below is the panel cutout (7.24"x5.16" [184x131 mm]) and mounting dimensions for all 5.7" LCD models:

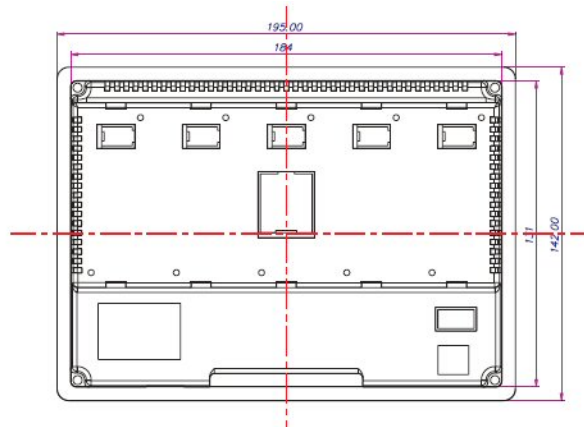

NOTE: the maximum panel thickness should be no more than 0.26" [6.5mm] (tolerance ± 0.0004 " [± 0.01 mm])

► Procedure to mount the unit:

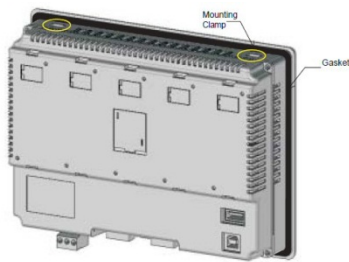

Figure 1

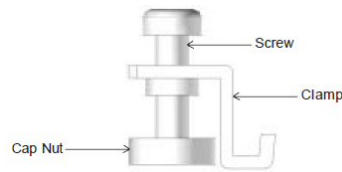

Figure 2

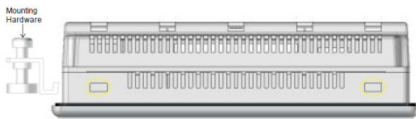

Figure 3

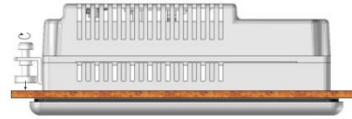

Figure 4



Figure 5: Make a cutout in the panel to the required size.

- Place the unit into the panel. The sealing gasket is placed directly behind the HMC bezel. (Note: use a sealing adhesive in installations in which the panel surface is rough or uneven).
- On each HMC, there are four mounting slots. Four mounting clamps (with clamp, bolt, and cap nut) are included with each HMC. Insert each clamp into the mounting slots. Hold the unit in place, while you tighten the mounting bolts evenly (to about 0.5 lb-ft of torque).

Caution: Do not over-tighten the screws beyond snugness or you may damage the housing or warp the overlay.

Panel Cutout and Mounting for the HMC7070A-M models:

Below is the panel cutout (7.24"x5.16" [184x131 mm]) and mounting dimensions for all 7.0" LCD models:

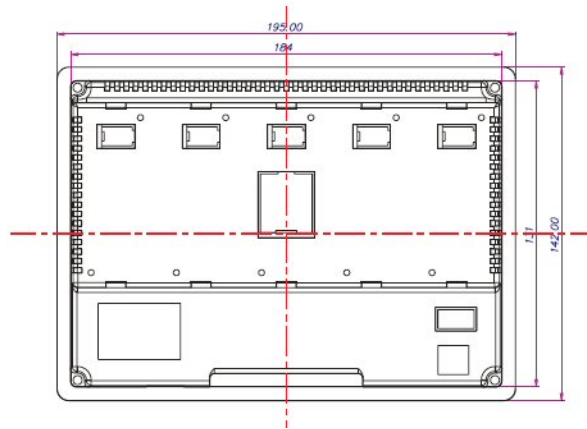

NOTE: the maximum panel thickness should be no more than 0.26" [6.5mm] (tolerance ± 0.0004 " [± 0.01 mm])

► Procedure to mount the unit:

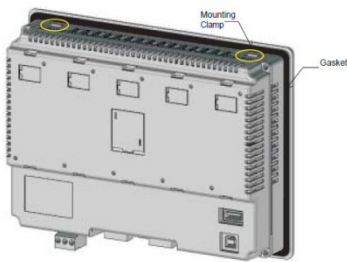

Figure 1

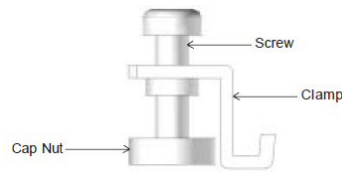

Figure 2

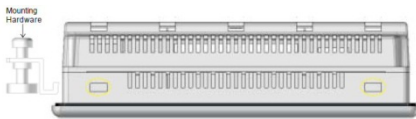

Figure 3

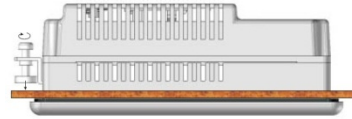

Figure 4

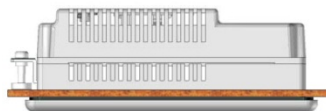

Figure 5: Make a cutout in the panel to the required size.

- Place the unit into the panel. The sealing gasket is placed directly behind the HMC bezel. (Note: use a sealing adhesive in installations in which the panel surface is rough or uneven).
- On each HMC, there are four mounting slots. Four mounting clamps (with clamp, bolt, and cap nut) are included with each HMC. Insert each clamp into the mounting slots. Hold the unit in place, while you tighten the mounting bolts evenly (to about 0.5 lb-ft of torque).

Caution: Do not over-tighten the screws beyond snugness or you may damage the housing or warp the overlay.

Panel Cutout and Mounting for the HMC2070A-M, HMC3070A-M, and HMC4070A-M models:

Below is the panel cutout (6.85"x4.96" [174x126 mm]) and mounting dimensions for all 7.0" LCD models:

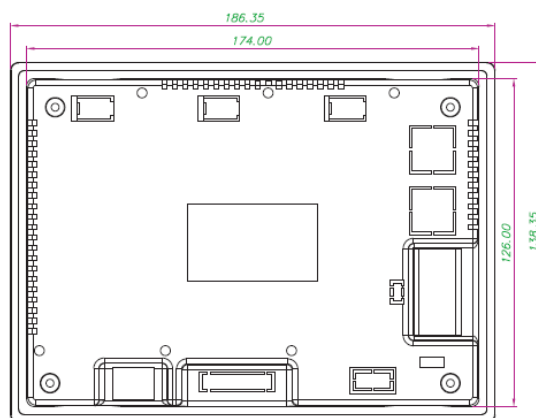

NOTE: the maximum panel thickness should be no more than 0.24" [6mm] (tolerance ± 0.0008 " [± 0.02 mm])

► Procedure to mount the unit:



Figure 1

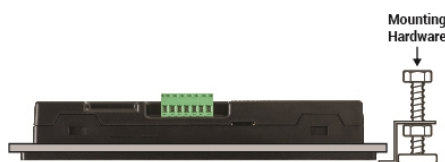

Figure 2



Figure 3



Figure 4

Figure 5: Make a cutout in the panel to the required size.

- Place the unit into the panel. The sealing gasket is placed directly behind the HMC bezel. (Note: use a sealing adhesive in installations in which the panel surface is rough or uneven).
- On each HMC, there are four mounting slots. Four mounting clamps (with clamp, bolt, and cap nut) are included with each HMC. Insert each clamp into the mounting slots. Hold the unit in place, while you tighten the mounting bolts evenly (to about 0.3 lb-ft of torque).

Caution: Do not over-tighten the screws beyond snugness or you may damage the housing or warp the overlay.

Panel Cutout and Mounting for the HMC2101A-M, HMC3102A-M, and HMC4101A-M models:

Below is the panel cutout (10.04"x6.97" [255x177 mm]) and mounting dimensions for all 10.2" LCD models:

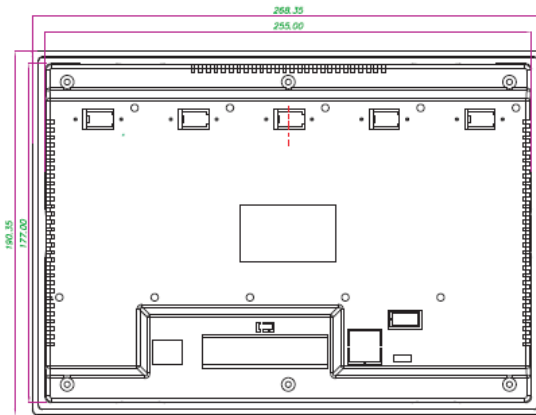

NOTE: the maximum panel thickness should be no more than 0.24" [6mm] (tolerance ± 0.0008 " [± 0.02 mm])

► Procedure to mount the unit:



Figure 1



Figure 2



Figure 3



Figure 4

Figure 5: Make a cutout in the panel to the required size.

- Place the unit into the panel. The sealing gasket is placed directly behind the HMC bezel. (Note: use a sealing adhesive in installations in which the panel surface is rough or uneven).
- On each HMC, there are four mounting slots. Four mounting clamps (with clamp, bolt, and cap nut) are included with each HMC. Insert each clamp into the mounting slots. Hold the unit in place, while you tighten the mounting bolts evenly (to about 0.3 lb-ft of torque).

Caution: Do not over-tighten the screws beyond snugness or you may damage the housing or warp the overlay.

REINSTALLATION: If, at any time, you are required to reinstall an HMC into a panel, be aware that the gasket will take a 'set' to the panel and may no longer provide an adequate NEMA 4 seal. Therefore, for best results, we recommend that you replace the gasket if reinstallation is required.

Installing the I/O Expansion Modules

Mounting the expansion modules onto a HMC7000 Series model:

- The expansion modules have two (2) locking connectors as shown in the diagram below:

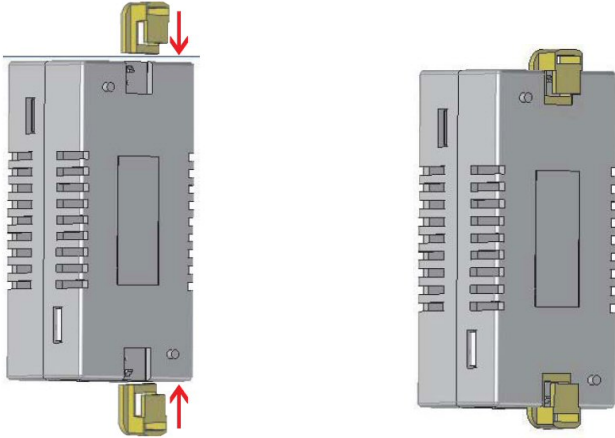

- Pull out the lock connectors to attach the I/O Expansion module to slots on the HMC:

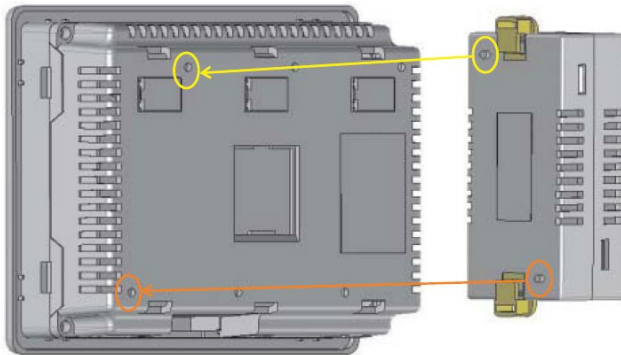

NOTE: you must remove the protective tab directly below the 'Expansion Port #' label so that the I/O Expansion interconnect plug can attach to the HMC socket.

- Push down the lock connectors to safely secure the I/O Expansion module:



To remove the expansion module, simply pull out the lock connectors (on both sides) and gently pull the module apart from the HMC.

Mounting the expansion modules onto HMC2000/HMC3000/HMC4000 Series models:

- Each expansion slot on the HMC2000/HMC3000/HMC4000 has two mounting threads and one IO connector:



- Attach the IO Expansion module using the IO connector and aligning the mounting screws to the threads:



- Push down the IO module then tighten the screws to safely secure the I/O Expansion module:



To remove the expansion module, simply pull out the lock connectors (on both sides) and gently pull the module apart from the HMC.

Control Panel Grounding

The control panel must be connected to a good, high-integrity earth ground both for safety considerations and shielding purposes. Maple Systems cannot overemphasize the importance of good grounding. If you fail to use good grounding procedures during installation, sporadic malfunction of the HMC may occur. Connect the HMC chassis ground terminal to a reliable earth ground with a low-resistance path.

Route all earth ground wires that lead from the HMC, the PLC, the power supply, and the line filter to a central earth ground point such as a barrier strip. This will ensure that no ground current from one device influences the operation of the other devices.

Connect the HMC chassis ground terminal to the control panel door using a heavy-gauge short braided cable or ground wire to minimize resistance. Connect the power cable's shield wire to the HMC chassis ground terminal. Connect the control panel to earth ground using a copper grounding rod close to the HMC and control panel.

Hinged doors on control panels do not provide a long-term electrical connection to the rest of the enclosure. Corrosion develops over time and prevents good electrical contact. For this reason, a separate wire braid should be installed from the hinged control panel to the rest of the enclosure.

For a more in-depth overview of ground wiring techniques, refer to Technical Note #1027, "OIT Ground Wiring and Electrical Noise Reduction," which you can find in the Tech Notes section on our web site.

Connect HMC Chassis Ground to Control Panel

To reduce the possibility of electrical interference, connect the chassis ground terminal of the HMC to a clean earth ground. Ensure that the HMC is grounded separately from other high-power systems. Use a single-point ground if grounding more than one unit.

If the control panel is metal, make sure it is properly grounded. Then connect a short heavy gauge wire (#14 AWG) from the chassis ground terminal of the HMC to a mounting bolt on the control panel door. The mounting bolt must have good electrical contact to the control panel; scrape away any paint that may be covering the panel to provide a good connection.

NOTE: *If the control panel is made of a non-conductive material, it is essential that you connect the chassis ground terminal of the HMC to a clean earth ground point located close to the panel.*

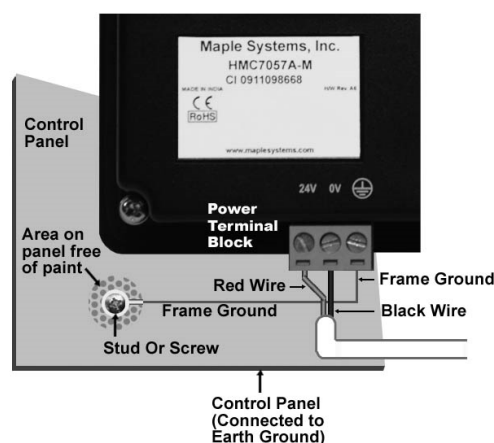

Figure 2: Chassis Ground Connection

NOTE: *Do not use a ground that has an unstable impedance, such as painted screws, or ground subject to vibration.*

Power Supply Selection

The power supply used to power the HMC should provide an output of +24 VDC $\pm 20\%$ measured at the HMC power terminal block. A 24VDC regulated power supply *dedicated to the HMC* is recommended. Use a power supply with adequate current rating based upon your particular model (visit the Support Center Specifications page on our website).

Do not use the power supply used to provide power to the HMC to power switching relays, solenoids, or other active devices. Use appropriate surge suppression devices in areas subjected to lightning or power surges. Keep AC lines, high energy equipment cables and rapidly switching DC wiring separate from the HMC power and signal wires.

Connecting high voltages or AC power mains to the DC input will make unit unusable and may create an electrical shock hazard to personnel. Such a failure or shock could result in serious personal injury, loss of life and/or equipment damage.

DC voltage sources should provide proper isolation from main AC power and similar hazards.

A power line filter installed at the AC input to the HMC power supply is highly recommended as a safeguard against conducted RF noise, which is often present on factory power lines. The wires connecting the output of the power line filter to the power supply should be kept as short as possible to minimize any additional noise pickup. The case of the power line filter should be connected to a quiet earth ground. The power line filter should have a current rating of at least 3 Amps with common mode and differential mode attenuation. In applications that may have high frequency noise present, we also recommend using a resistor ($\sim 1 \text{ M}\Omega$) and capacitor ($\sim 4700 \text{ pF}$) in parallel to clean earth ground on the DC output of the power supply.

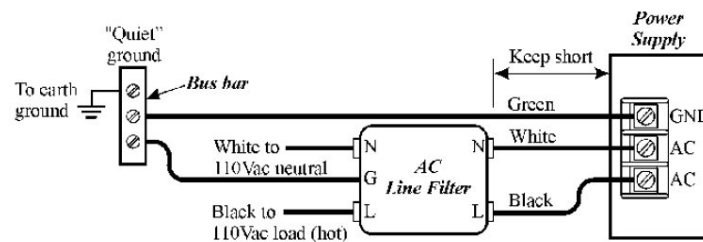

Figure 3: Power Line Filter Connection

Cable Routing and Noise Immunity

Follow these guidelines when routing cables to the HMC:

- Always route the HMC communication cable and the power cable away from any AC voltage or rapidly switching DC control lines.
- Never bundle the HMC cables together with 120VAC power wires or with relay wiring.
- Try to keep at least 8 inches (20 cm) of separation between the HMC cables and other power wiring. If voltages greater than 120VAC are used in the system, greater separation is required.
- If the HMC cables must come near AC wiring, make sure they cross at 90 degrees.
- Run AC power wires in a separate grounded conduit to reduce electrical noise interference.
- Keep the cable lengths for the HMC as short as possible. Do not coil excess cable and place it next to AC powered equipment.
- Cover any equipment used in the enclosure that operates at high frequency or high current levels with a grounded metal shield.

Connect the HMC to Power

Use the separate 3-position terminal block supplied to provide power to the HMC.

The power cable for the HMC should be 18AWG, 2-conductor wire with a shield drain wire and protective shield (foil/braid). You may buy cable P/N 6030-0009 by the foot from Maple Systems to make your own power cable.

Always run the DC ground wire directly back to the signal return of the power supply. *Do not use the chassis ground wire as your signal return.*

Caution: To prevent possible damage to the HMC, we recommend waiting ten seconds after removing power to the HMC before applying power again.

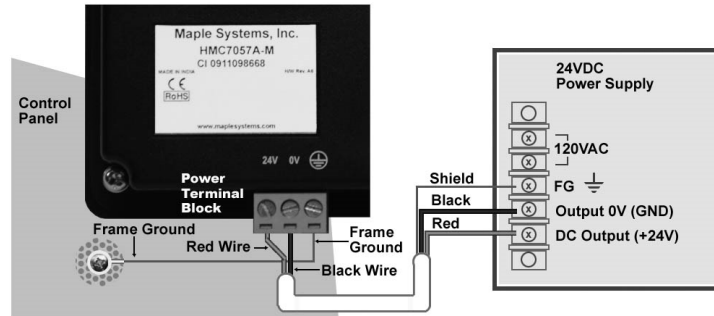
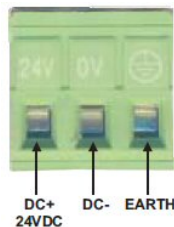

Figure 4: HMC Power Wiring

To connect the HMC to power:

1. Connect the power cable to the HMC.
 - a. Strip cable shield to expose 2" of the black/red wires.
 - b. Strip ¼" of insulation from the black/red wires.
 - c. Connect red wire to the 24V DC positive (+) input.
 - d. Connect black wire to the 24V DC negative (-) input.
 - e. Connect power shield wire to chassis ground input.
2. Route the power cable to the HMC power supply. The power cable should not be any longer than necessary.
3. Install the power supply wires as follows (with colors shown for Maple Systems cable P/N 6030-0009):

Color	Power Supply	HMC
Red	+Output/+24VDC	+24V
Black	-Output/+24VDC return	GND
Shield	Case ground	FG or Earth



NOTE: The power connector on the HMC Series uses a 3-position terminal block with screw-down clamps. Lugs are not required.

Communication Ports

The HMC Series supports four types of communication ports (Ethernet, serial, USB Slave/Host, and SD card).

Serial Ports

COM1/2 port (HMC2043A-M, HMC3043A-M, HMC4043A-M, and HMC7043A-M models)

The 4.3" model has two serial ports (COM1 and COM2) which share the same physical connector located on the back of the unit. The COM1 port has RS232 while the COM2 port supports RS422 four-wire or RS485 two-wire connections. RS485/RS422 supports multi-drop network (depending on protocol driver selected):

DE9S female connector

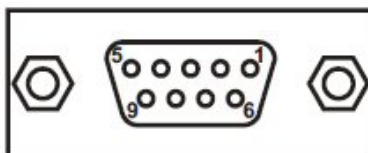

Pin out Diagram:

Pin Number	Name	Description	Port
1	TX+	RS422 transmit +	COM2
2	TXD	RS232 transmit	COM1
3	RXD	RS232 receive	COM1
4	RX+	RS422 receive +	COM2
5	GND	Ground	COM1/COM2
6	NC	No connection	
7	NC	No connection	
8	TX-	RS422 transmit -	COM2
9	RX-	RS422 receive -	COM2
Shell			Shield

Note: for 2 wire RS485, jumper Pins 1 (TX+) and 4 (RX+).

Also jumper Pins 8 (TX-) and 9 (RX-).

Cable shield wire should be connected to shell.

COM1 port only (HMC7030, HMC7035 models)

COM2 port only (HMC2070A-M, HMC3070, and HMC4070A-M models)

COM1, and COM2 ports (HMC2101A-M, HMC3102A-M, HMC4101A-M, HMC7057, and HMC7070 models)

This port supports RS232, RS422 four-wire and RS485 two-wire connections. RS485/RS422 supports multi-drop network (depending on protocol driver selected):

DE9S female connector

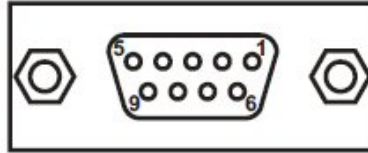

Pin out Diagram:

Pin Number	Name	Description
1	TX+	RS422 transmit +
2	TXD	RS232 transmit
3	RXD	RS232 receive
4	RX+	RS422 receive +
5	GND	Ground
6	NC	No connection
7	NC	No connection
8	TX-	RS422 transmit -
9	RX-	RS422 receive -

Note: for 2 wire RS485, jumper Pins 1 (TX+) and 4 (RX+).

Also jumper Pins 8 (TX-) and 9 (RX-).

Cable shield wire should be connected to shell.

COM1 port (HMC2070A-M, HMC3070A-M, and HMC4070A-M models)

The COM1 port on the HMC2070A-M, HMC3070A-M and HMC4070A-M units supports RS232, RS422 four-wire and RS485 two-wire connections using a terminal block plug. The RS485/RS422 connection can be used in multi-drop network communications (provided the protocol driver selected supports this):

7 position plug-in terminal block

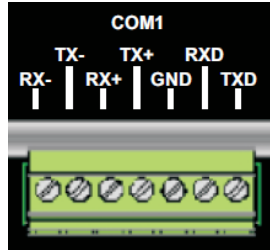

Pin out Diagram COM1:

Pin Number	Name	Description
1	RX-	RS422 receive -
2	TX-	RS422 transmit -
3	RX+	RS422 receive +
4	TX+	RS422 transmit +
5	GND	Ground
6	RXD	RS232 receive
7	TXD	RS232 transmit

Note: for 2 wire RS485, jumper Pins 4 (TX+) and 3 (RX+).
Also jumper Pins 2 (TX-) and 1 (RX-).

Ethernet port

The Ethernet (10/100 Mbps) port can be used for configuration and communicating with supported controllers.

HMC models supported:

- HMC2043A-M
- HMC2070A-M
- HMC2101A-M
- HMC3043A-M
- HMC3070A-M
- HMC3102A-M
- HMC4043A-M
- HMC4070A-M
- HMC4101A-M
- HMC7043A-M
- HMC7070A-M

USB Client (Slave) port

This port is used solely for downloading/uploading projects into the HMC unit. The port complies with the USB 2.0 specification. All HMC units include a USB Client port. Note: See Configuration Wiring below for type of connector depending upon model.

USB Host port

This port is used for data logging and historical alarms when you attach a USB Flash Drive. It is compliant with USB 2.0 specification and has a standard USB Type A connector. This port is available in the following HMC models:

- HMC2043A-M
- HMC2070A-M
- HMC2101A-M
- HMC3043A-M
- HMC3070A-M
- HMC3102A-M
- HMC4043A-M
- HMC4070A-M
- HMC4101A-M
- HMC7030A-M
- HMC7035A-M
- HMC7043A-M
- HMC7057A-M
- HMC7070A-M

Micro SD Card port

This port is used for data logging and historical alarms when you attach a micro SD card. The card used should be 4GB-32GB compliant with speed class 1, 2, 4, 6 or 10. The HMC unit should be off when inserting or removing the SD card. This port is available in the following HMC models:

- HMC3043A-M
- HMC3070A-M
- HMC3102A-M

Configuration Wiring

All HMC units are configured using the MAPware-7000 software.

For USB connection:

Model	USB Host connector	Maple USB cable
HMC2000, HMC3000, and HMC4000 Series	Micro- USB B type	7431-0119
HMC7030A, 7035A, 7043A, 7057A, 7070A	USB- B type	7431-0116

The HMC7043, HMC7070, and HMC2000, HMC3000, and HMC4000 Series models can also be configured with an Ethernet cable. Use a crossover cable (Maple P/N 7431-0104) if connecting directly from the PC. If connecting through a switch or router, use a straight-through cable (Maple P/N 7431-0103).

Connecting to Peripherals

I/O Expansion Modules

The HMC Series (except for the HMC3020A and HMC7030A-L models) support I/O expansion modules. These modules are used to connect directly to digital and analog inputs/outputs for electrical control systems.

Note: the HMC7 I/O expansion modules are compatible only with the HMC7000 Series models. The HMC3 I/O expansion modules are compatible with the HMC2000, HMC3000, and HMC4000 Series models.

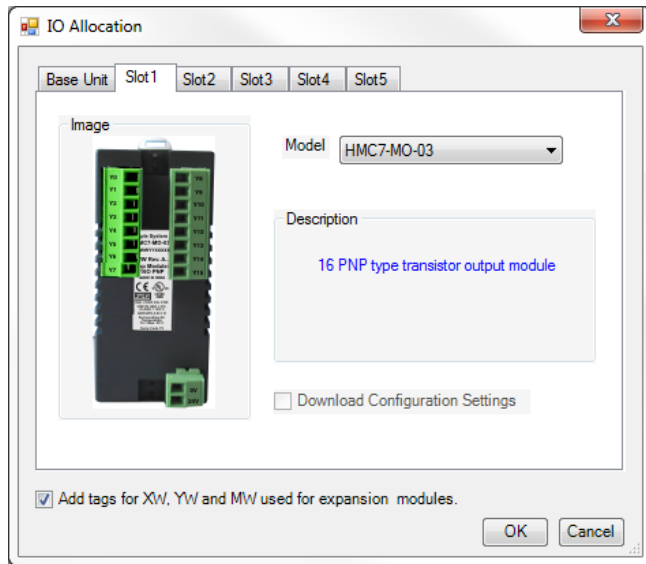

HMC7 I/O Expansion Modules

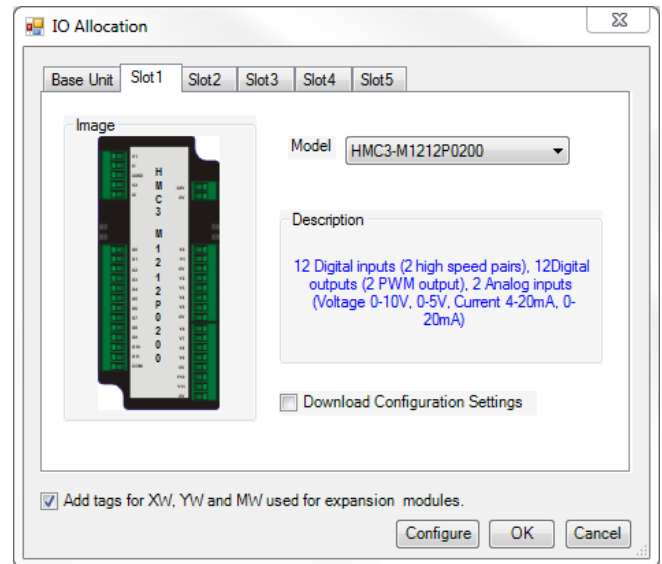

HMC3 I/O Expansion Modules

For more information please see *I/O Module Guide for the HMC7000 Series* (P/N 1010-1043) or the *I/O Module Guide for the HMC3000 Series* (P/N 1010-1057).

PLCs/Controllers

All of the HMC Series (except the HMC2020) have at least one serial port that can be used to connect to an external programmable logic controller (PLC). The MAPware-7000 configuration software supports most major PLC manufacturers including PLCs from Allen Bradley (Rockwell Automation), Schneider Electric (Modbus RTU), Siemens, Omron, and GE Fanuc. Finally, many of the HMC models have two serial ports which allow simultaneous connections to two PLCs. Each serial port is individually configured so that you are not restricted to using only one PLC communications driver.

Connecting to a PLC

As mentioned above, an external PLC can be connected to the HMC Series via a serial port using RS232, RS422 four wire, or RS485 two wire connections. Other HMC models can also connect to certain PLCs by Ethernet.

In addition to making the physical connection to the external PLC, you must also configure the communications parameters (i.e. communications driver, baud rate, etc.) using the MAPware-7000 software:

1. Open a new project and select which product you wish to use. Click OK.
2. In the Network Configuration folder of the Project Information Window, right-click on the port you wish to configure, then click Add to display the Node Information dialog box:

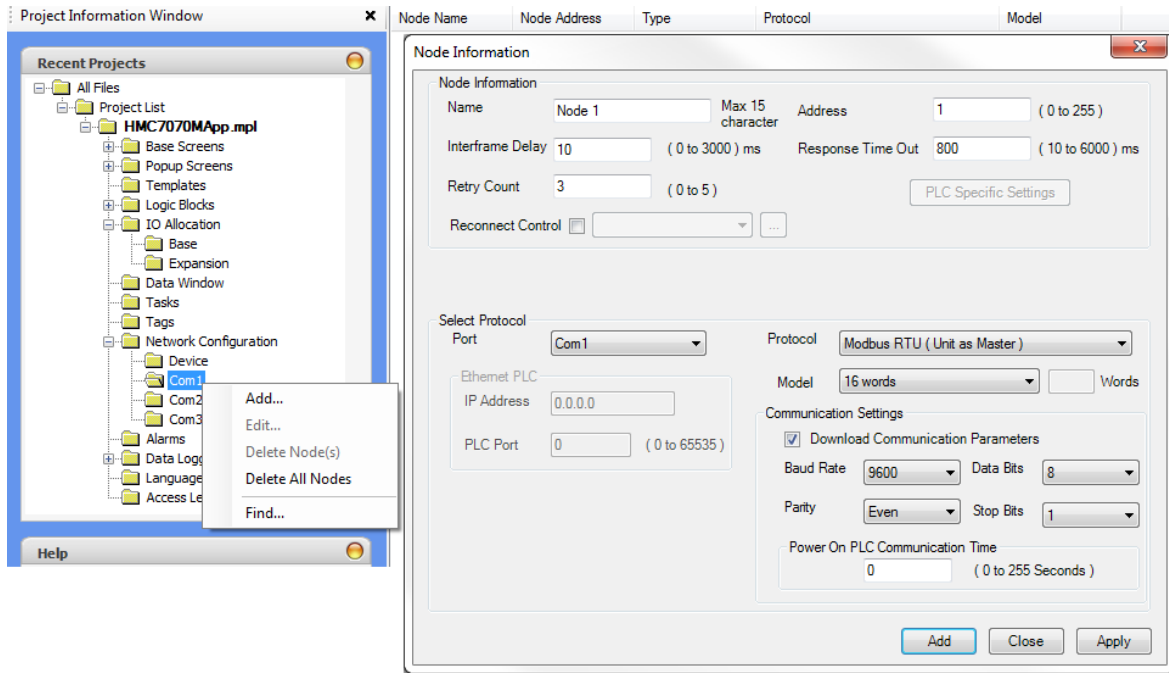

In the Select Protocol section, choose from the Protocol list box the appropriate protocol driver for your PLC. Click on the Model list box to select the particular PLC model that most closely matches your PLC

3. In the Communication Settings section, enter the communications parameters that the HMC will use to attempt communications with your external PLC. For more specific information about each external PLC supported, please visit our Support Center-Controller Info Sheets at our website: www.maplesystems.com.
4. Click OK.
5. To make any changes or edits, simply right-click on the Com1/Com2/Com3 folder and select Edit.
6. Note that you do not have to assign the external PLCs at the time that a new project is created. You can always add the drivers later by right-clicking the appropriate Com port:

After assigning an external PLC to one of the COM ports on the HMC, you can read/write to the internal memory of the attached PLC. To do this, you must first assign tags to the PLC memory using the tag database:

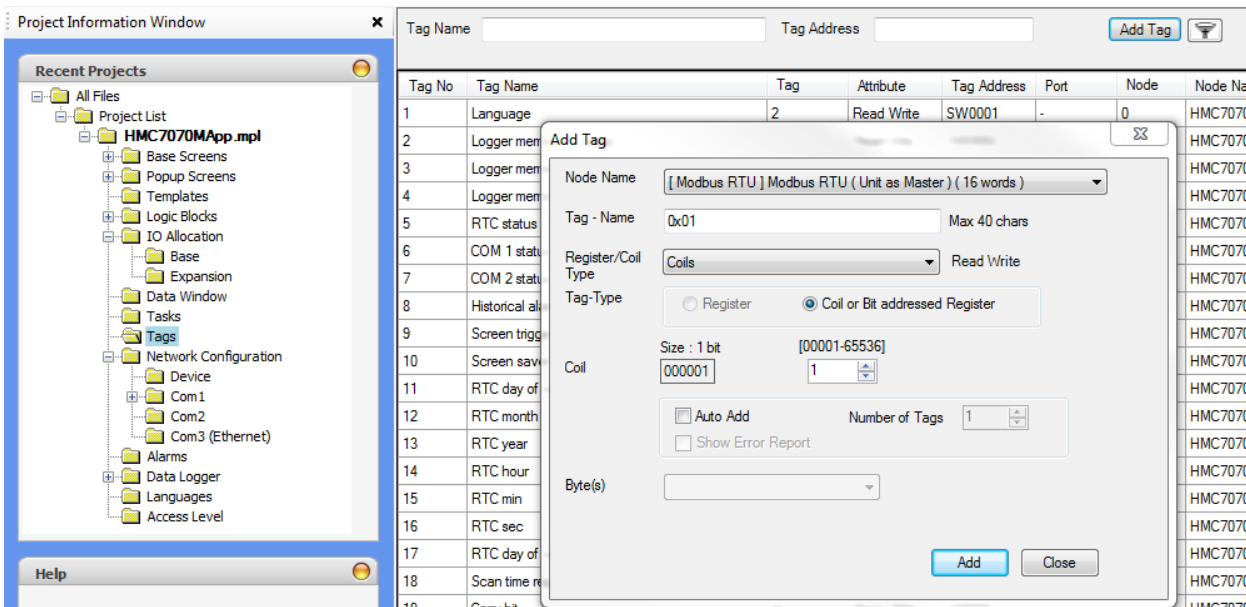

Once PLC memory addresses have been assigned to the tag database, you can then read/write to the PLC in your project.

Serial Printer

The MAPware-7000 software supports the ability to assign a serial printer to one of the serial Com ports on the HMC. This is done in much the same way as assigning an external PLC (see last section):

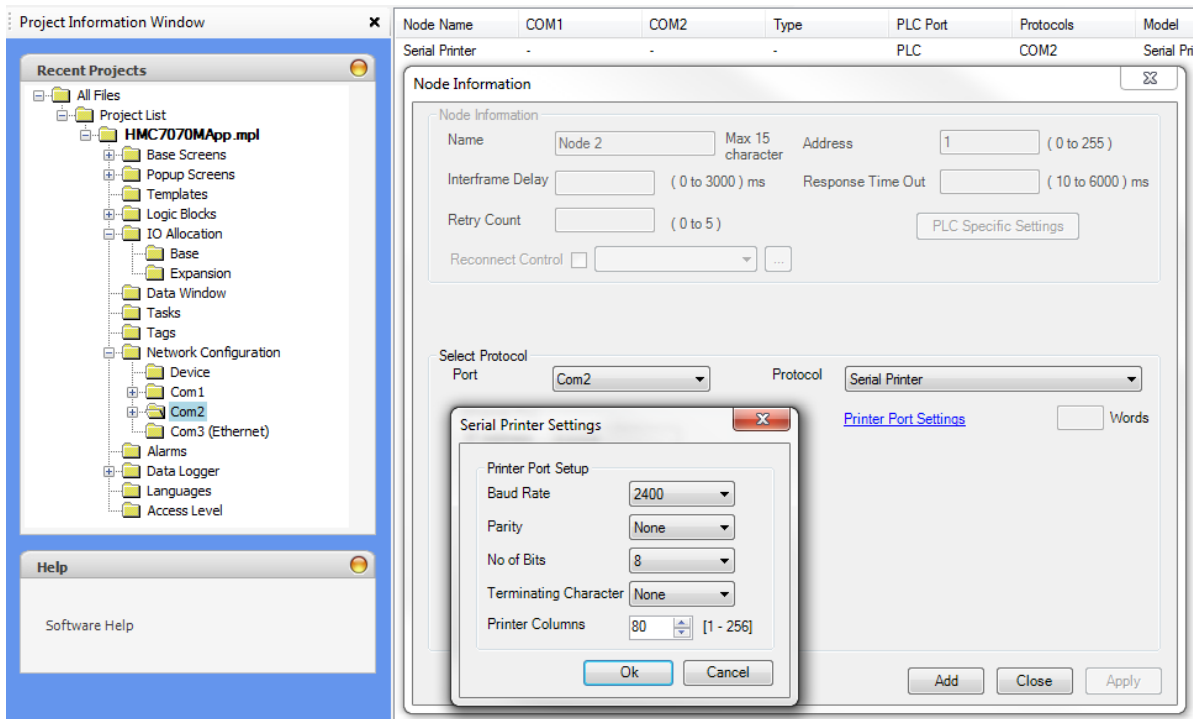

Attributes:

Port: select which serial COM port is connected to the printer.

Printer Port Settings- click on this option to set communications parameters.

Baud Rate- baud rate setting for the serial printer

Parity- parity setting for the serial printer

No of Bits- the number of data bits set on the serial printer

Terminating Character- the type of terminating character issued by the serial printer after reaching the end of the columns. Default is *None*.

Printer Columns – the total number of columns or number of characters printed before the terminating character is issued. Range is 1 to 256, default is 80.

NOTE: when printing a screen, the HMC can only print text characters that appear on the screen- no graphics. You can send data to the serial printer in a number of ways:

- Set the Screen Print Properties attribute for a screen
- Use a Function Key to Print Data
- Set a Function Key to Key Specific Task-Print Group

USB Flash Drive

Each HMC model has a built-in USB Device (Slave) port. This port is used solely for uploading/downloading projects to the unit using a USB cable attached to the USB port on your computer.

Most of the HMC models also have a USB Host port with a Type A receptacle connector. This port can be used to upload/download projects that have been loaded onto a USB Flash drive. This port is also used by the Data Logger feature.

Uploading/Downloading Projects via Flash

In addition to uploading/downloading a project through the customary method of connecting a USB cable to a computer that contains MAPware-7000, you can also use the USB Host port on many HMC models to upload/download projects using a USB Flash Drive. The Flash Drive must be formatted as FAT32. Although Maple Systems has not tested every Flash Drive manufactured, Flash Drives from the following manufacturers have been found to work with the HMC units:

- PNY: Attaché (4-8GB)
- SanDisk: Cruzer Micro (2-8GB)
- Transcend: JF V30 (1-8GB)
- Kingston: Data Traveler (4-8GB)
- Sony: Micro Vault (2-8GB)

When using a Flash Drive with your HMC unit, make sure that all important data is backed up to a safe location on another storage medium.

Before you can upload/download a project, the HMC must have a project running that contains a screen with a Set Bit button object. This object is tagged to internal memory bit S00037 – the USB Host Menu trigger:



NOTE: this is just an example; you can create any type of screen as long as you have a Set Bit object that is tagged to S00037.

When the project is running, the operator must press the Set button to set internal coil address S00037 (make sure that a Flash Drive is inserted into the USB Host port of the HMC). This displays the following screen on the HMC:



Click the Yes button to display the next screen in sequence:



After a few moments, the following screen is displayed:

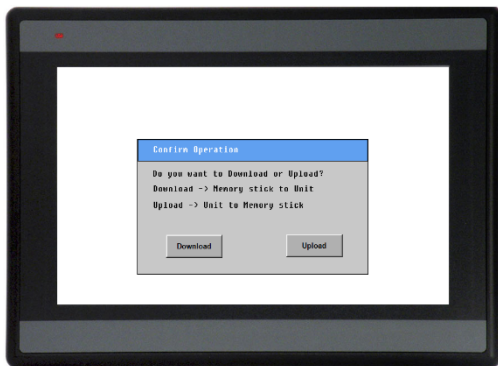

Uploading a HMC project onto a Flash Drive

Click the Upload button on the HMC screen if you wish to transfer a project currently located in the HMC to an attached Flash Drive.

The following screen appears:

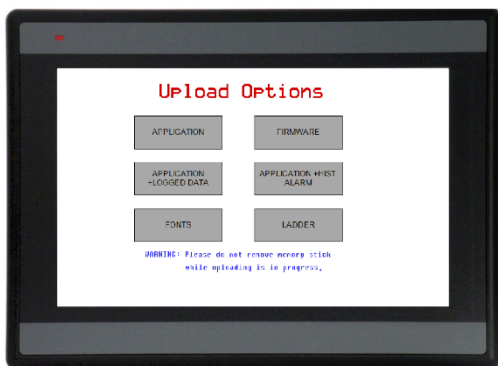

Options include:

- Application – uploads only the application project to the flash drive. The project is saved as an *.MPL file.
- Application + Logged Data – uploads the project and any data logged.
- Fonts – uploads the font files used to create all text objects. The font files are saved as FONT_File.BIN.
- Firmware – uploads the firmware for the HMC. The firmware is saved as an *.ABS file.
- Application + Hist. Alarm – uploads the project and any historical alarm data collected.
- Ladder – uploads the ladder logic only.

Click one of the options above to proceed to upload:



Click OK to begin:

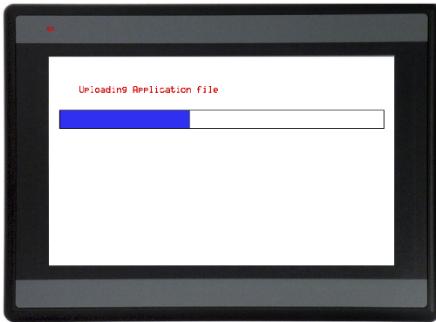

This process can take several minutes to complete. When completed, the following screen appears:

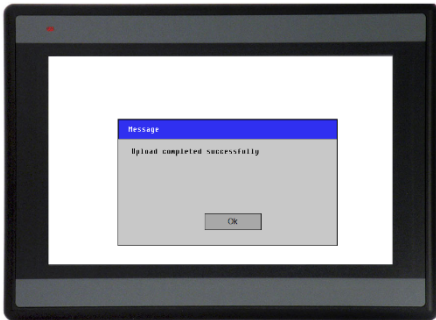

Click the OK button. The HMC then displays the Upload Options screen. Click the Exit button. Unit will reboot and run the internal project.

Downloading a HMC project from a Flash Drive

Click the Download button on the HMC screen if you wish to transfer a project located in the flash drive to the HMC. Note that this will delete whatever file that currently resides in the HMC.

The following screen appears:

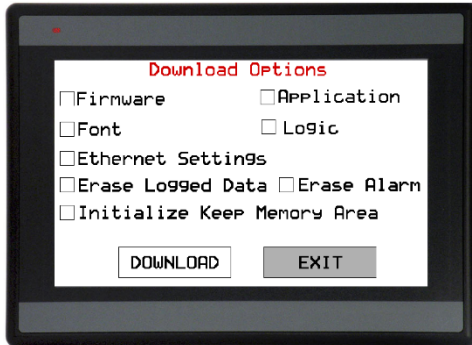

Options include:

- Application – downloads only the application project (*.mpl) to the HMC
- Fonts – downloads the font file used to create all text objects
- Firmware – downloads the firmware to the HMC
- Logic – downloads the ladder logic only
- Ethernet Settings – downloads the IP address settings
- Erase Logged Data – option to erase any captured data from the Data Logger feature
- Initialize Keep Memory Area – option to clear the Keep Memory area

Click one of the options above to proceed to download:



Click OK to begin:

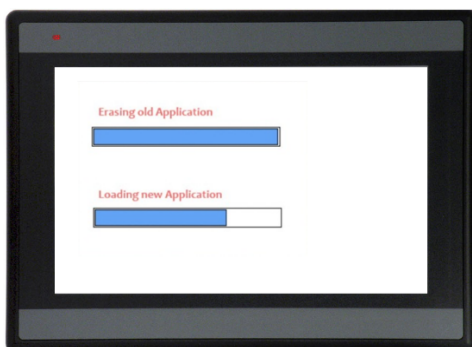

This process can take several minutes to complete.

When completed, the following screen appears:

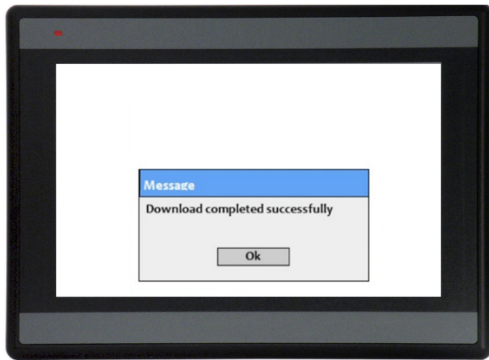

Click the OK button. The HMC then displays the Download Options screen. Click the Exit button. Unit will reboot and display the following:

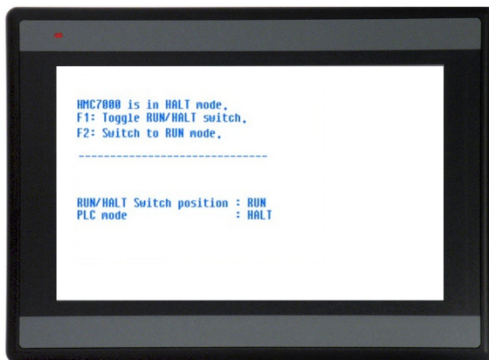

Press the F2 function key on the HMC to run the internal project.

Now that you have a general knowledge of the hardware features for the HMC Series, please consult the HMC Series Programming Manual for information on how to use the many software features available.

Your Industrial Control Solutions Source

www.maplesystems.com



1010-1042 Rev. 05

Maple Systems, Inc. | 808 134th St. SW, Suite 120, Everett, WA 98204 | 425.745.3229