

Weighing systems

Electronic weighing system SIWAREX WP231

Operating Instructions

7MH4960-2AA01

Introduction	1
Safety notes	2
Description	3
Application planning	4
Mounting	5
Connecting	6
Commissioning	7
Scale parameters and functions	8
Messages	9
Command lists	10
Communication	11
Operation requiring verification	12
Technical data	13
Ordering data	14
Product documentation and support	A
ESD guidelines	B
Abbreviations	C

Legal information

Warning notice system

This manual contains notices you have to observe in order to ensure your personal safety, as well as to prevent damage to property. The notices referring to your personal safety are highlighted in the manual by a safety alert symbol, notices referring only to property damage have no safety alert symbol. These notices shown below are graded according to the degree of danger.

⚠ DANGER
indicates that death or severe personal injury will result if proper precautions are not taken.

⚠ WARNING
indicates that death or severe personal injury may result if proper precautions are not taken.

⚠ CAUTION
indicates that minor personal injury can result if proper precautions are not taken.

NOTICE
indicates that property damage can result if proper precautions are not taken.

If more than one degree of danger is present, the warning notice representing the highest degree of danger will be used. A notice warning of injury to persons with a safety alert symbol may also include a warning relating to property damage.

Qualified Personnel

The product/system described in this documentation may be operated only by **personnel qualified** for the specific task in accordance with the relevant documentation, in particular its warning notices and safety instructions. Qualified personnel are those who, based on their training and experience, are capable of identifying risks and avoiding potential hazards when working with these products/systems.

Proper use of Siemens products

Note the following:

⚠ WARNING
Siemens products may only be used for the applications described in the catalog and in the relevant technical documentation. If products and components from other manufacturers are used, these must be recommended or approved by Siemens. Proper transport, storage, installation, assembly, commissioning, operation and maintenance are required to ensure that the products operate safely and without any problems. The permissible ambient conditions must be complied with. The information in the relevant documentation must be observed.

Trademarks

All names identified by ® are registered trademarks of Siemens AG. The remaining trademarks in this publication may be trademarks whose use by third parties for their own purposes could violate the rights of the owner.

Disclaimer of Liability

We have reviewed the contents of this publication to ensure consistency with the hardware and software described. Since variance cannot be precluded entirely, we cannot guarantee full consistency. However, the information in this publication is reviewed regularly and any necessary corrections are included in subsequent editions.

Table of contents

1	Introduction	11
1.1	Purpose of this documentation.....	11
1.2	Use in hazardous area.....	11
1.3	Document history.....	12
1.4	Product compatibility.....	12
1.5	Checking the consignment.....	13
1.6	Security information.....	13
1.7	Transportation and storage.....	14
1.8	Basic knowledge required.....	14
1.9	Notes on warranty.....	14
2	Safety notes	15
2.1	General safety instructions.....	15
3	Description	17
3.1	Product overview.....	17
3.2	Information about previous versions.....	17
3.3	Operation requiring official calibration.....	18
3.4	Area of application.....	18
3.5	System integration in SIMATIC.....	19
3.6	Customer benefits.....	19
4	Application planning	21
4.1	Functions.....	21
4.2	Parameter assignment options.....	22
4.2.1	Parameter assignment with the PC.....	22
4.2.2	Parameter assignment with a SIMATIC Panel.....	22
4.2.3	Parameter assignment by means of the Modbus interface.....	23
5	Mounting	25
5.1	Basic safety notes.....	25
5.1.1	ATEX Special conditions for use.....	25
5.2	Installation guideline.....	25
5.3	EMC-compliant setup.....	26
5.3.1	Introduction.....	26
5.3.2	Possible effects of interference.....	26
5.3.3	Coupling mechanisms.....	26
5.3.4	Five basic rules for securing EMC.....	27

5.4	Mounting on the SIMATIC S7-1200	28
6	Connecting	29
6.1	Basic safety notes	29
6.1.1	ATEX Special conditions for use	29
6.2	Overview	30
6.3	24 V connection	31
6.4	Connection of analog load cells	31
6.4.1	Connecting SIWAREX JB to the electronic weighing system and load cell	31
6.4.2	Wiring diagrams	32
6.4.2.1	Load cells with four-wire system	32
6.4.2.2	Load cells with six-wire system	33
6.4.3	Connecting the cable	34
6.5	Shield connection	34
6.6	Connection of digital outputs (4 x DQ)	35
6.7	Connection of digital inputs (4 x DI)	36
6.8	Connection of the analog output (1 x AQ)	37
6.9	Connection of RS485 serial interface	37
6.10	Connection of Siebert display via RS485	38
6.11	Connection of digital load cells from the Wipotec company	38
6.11.1	Electrical connection of load cells with plug-in connection	39
6.11.2	Electrical connection of load cells with terminal block (SW-D-FS series)	39
6.12	Connection of digital load cells from the Mettler-Toledo company	41
6.13	Connection of the SIWAREX DB	43
6.13.1	Connect SIWAREX DB to SIWAREX WP electronic weighing system and load cell	43
6.13.2	Connect the cable	45
6.14	Connection of the Ethernet interface	45
6.15	Activation of write protection	46
6.16	Mounting of the calibration protection plate	46
7	Commissioning	47
7.1	Introduction	47
7.2	Factory-set parameters	47
7.3	Commissioning tools	47
7.4	Factory setting of the mode selector	48
7.5	5 minute quick start with the operator panel and the Ready-for-Use software	48
7.5.1	Start	48
7.5.2	Standard parameter settings	49
7.5.3	Selecting the calibration method	50
7.5.4	Defining the calibration weights	51
7.5.5	Setting calibration points	52
7.5.6	Calibrating the scale automatically	53

7.5.7	Performing the automatic calibration.....	54
7.5.8	Checking the scale following calibration	54
7.6	5 minute quick setup with SIWATOOL.....	54
7.6.1	Activate service mode	55
7.6.2	Load standard parameters	55
7.6.3	Input of required parameters	55
7.6.4	Complete automatic calibration	56
7.6.5	Receive all data.....	56
7.6.6	Checking the scale following calibration	56
7.7	Service with the SIWATOOL program	57
7.7.1	Windows and functions of SIWATOOL	58
7.7.2	Offline parameter assignment	59
7.7.3	IP address for SIWAREX	59
7.7.3.1	Entering a known SIWAREX IP address.....	59
7.7.3.2	Determining an unknown IP address	60
7.7.3.3	Setting up a network	60
7.7.4	Online parameter assignment	60
7.7.5	Available help options	61
7.7.6	Entering parameters with SIWATOOL	61
7.7.7	Recording scale traces.....	61
7.7.8	Reading out the saved scale logs	62
7.7.9	Firmware update	62
8	Scale parameters and functions	65
8.1	Parameters and functions	65
8.2	Assigning parameters to the electronic weighing system with SIWAREX DB	65
8.3	DR 2 command code	66
8.4	DR 3 calibration parameters	66
8.4.1	Scale name	71
8.4.2	Unit of weight	71
8.4.3	Gross identifier	71
8.4.4	Load cell type	72
8.4.5	Code for regulations.....	72
8.4.6	Minimum weighing range	72
8.4.7	Maximum weighing range	72
8.4.8	Calibration weights 0, 1, 2 and calibration digits 0, 1, 2	73
8.4.9	Scale interval.....	73
8.4.10	Zero by power-on	73
8.4.11	Zero by power-on when tare \neq 0	73
8.4.12	Automatic zero adjustment.....	73
8.4.13	Subtractive / additive tare device	74
8.4.14	Weight simulation	74
8.4.15	Decimal places for process values.....	74
8.4.16	Maximum tare load.....	74
8.4.17	Maximum negative zero setting limit (power-on).....	75
8.4.18	Maximum positive zero setting limit (power-on)	75
8.4.19	Maximum negative zero setting limit (semi-automatically)	75
8.4.20	Maximum positive zero setting limit (semi-automatically)	75
8.4.21	Standstill range	75
8.4.22	Standstill time	76

8.4.23	Standstill waiting time.....	76
8.4.24	Low-pass cut-off frequency	77
8.4.25	Low-pass filter number	77
8.4.26	Low-pass filter limit frequency (commissioning).....	77
8.4.27	Low-pass filter number (commissioning).....	78
8.4.28	Mean value filter depth.....	78
8.4.29	Display weighing range data	78
8.4.30	Interface for legal trade display	78
8.4.31	Firmware version SecureDisplay	78
8.4.32	Minimum display size [%].....	78
8.5	Calibration procedure.....	79
8.5.1	Calibration with calibration weights	79
8.5.2	Automatic calibration	81
8.6	DR 4 Output of calculated calibration digits	82
8.6.1	Calibration digits 0, 1, 2 (calculated)	83
8.7	DR 5 zeroing memory	83
8.7.1	Effective tare weight - from specification 1, 2 or 3	84
8.7.2	Effective tare weight (semi-automatic)	84
8.7.3	Zero by power-on (value when switching on).....	84
8.7.4	Zero weight (semi-automatic).....	85
8.7.5	Current zero tracking weight	85
8.7.6	Dead load.....	85
8.8	DR 6 limit value settings.....	85
8.8.1	Limit reference	87
8.8.2	Limit value 1 ON, limit value 2 ON, limit value 1 OFF, limit value 2 OFF.....	87
8.8.3	Delay time for limit value 1 ON, delay time for limit value 2 ON.....	88
8.8.4	Delay time for limit value 1 OFF, delay time for limit value 2 OFF	88
8.8.5	Limit value "Empty" ON.....	88
8.8.6	Delay time for limit value "Empty" ON	89
8.9	DR 7 interface parameters	89
8.9.1	Assignment for digital input 0, 1, 2, 3	92
8.9.2	Input filtering (hardware setting).....	92
8.9.3	Assignment for digital output 0, 1, 2, 3.....	93
8.9.4	Response of digital outputs to faults or SIMATIC STOP.....	93
8.9.5	Substitute value for DQ 0, 1, 2, 3 following fault or SIMATIC STOP.....	93
8.9.6	Analog output range.....	94
8.9.7	Analog output source	94
8.9.8	Response of analog output to faults or SIMATIC STOP	95
8.9.9	Start value for the analog output.....	95
8.9.10	End value for the analog output	95
8.9.11	Output value following fault or SIMATIC STOP	95
8.9.12	Trace recording cycle.....	95
8.9.13	Trace storage method	96
8.10	DR 8 date and time	96
8.11	DR 9 module information	97
8.12	DR 10 load cell parameters.....	98
8.12.1	50/60 Hz toggling	99
8.12.2	Number of support points.....	99

8.12.3	Load cell characteristic value	99
8.12.4	Rated load of a load cell.....	99
8.13	DR 12 Ethernet parameters	100
8.13.1	Device MAC address	102
8.13.2	Port MAC address.....	102
8.13.3	IP address	102
8.13.4	Subnet mask	102
8.13.5	Gateway	102
8.13.6	Device name	102
8.13.7	Byte/Word swap options	103
8.14	DR 13 RS485 parameters	103
8.14.1	RS485 protocol	105
8.14.2	RS485 baud rate	105
8.14.3	RS485 character parity	105
8.14.4	RS485 number of data bits	105
8.14.5	RS485 number of stop bits.....	105
8.14.6	Byte/Word swap options	105
8.14.7	RS485 Modbus address.....	105
8.14.8	Decimal place for Siebert indicator	105
8.14.9	MODBUS RTU response delay.....	105
8.15	DR 14 SIMATIC interface parameters	106
8.15.1	Selection of process value 1, 2	106
8.16	DR 15 tare settings	107
8.16.1	Specification of tare weight 1, 2, 3	108
8.17	DR 16 simulation value	108
8.17.1	Weight simulation specification	109
8.18	DR 17 analog output control specifications.....	109
8.18.1	Analog output specification	110
8.19	DR 18 digital output control specifications	110
8.19.1	Specification for digital output 0, 1, 2, 3	111
8.20	DR 30 current process values.....	111
8.20.1	Gross process weight.....	114
8.20.2	Net process weight.....	114
8.20.3	Tare process weight.....	114
8.20.4	Gross / net weight	115
8.20.5	Gross / net weight with increased resolution (x 10)	115
8.20.6	Tare weight	115
8.20.7	Gross process weight (commissioning aid).....	115
8.20.8	Net process weight (commissioning aid).....	115
8.20.9	Refresh counter for process values	115
8.20.10	Last report ID	115
8.21	DR 31 advanced current process values	115
8.21.1	Unfiltered digit value.....	117
8.21.2	Filtered digit value	117
8.21.3	Filtered digit value (commissioning aid)	117
8.21.4	Digits for analog output	117
8.21.5	Current status of input 0, 1, 2, 3.....	117
8.21.6	Current status of digital output 0, 1, 2, 3	117

8.21.7	Refresh counter for process values	118
8.21.8	Current load cell signal in mV	118
8.22	DR 32 display of data and operator errors	118
8.22.1	Data and operator errors, bytes 0 to 7	120
8.22.2	Modbus RTU error code.....	120
8.22.3	Modbus Ethernet error code	120
8.22.4	SIWATOOL error code.....	120
8.22.5	Error code following commands at digital input.....	121
8.23	DR 34 ASCII main display value	121
8.23.1	Content of main display as ASCII string.....	121
8.24	DR 45 protocol request	122
8.24.1	Protocol ID to be read	123
8.25	DR 46 protocol contents.....	123
8.25.1	Oldest protocol ID	124
8.25.2	Newest protocol ID.....	124
8.25.3	Selected protocol ID, numeric	125
8.25.4	Gross / net identifier	125
8.25.5	G/N weight	125
8.25.6	Unit of weight	125
8.25.7	Tare identification.....	125
8.25.8	Date, time.....	125
8.26	DR 47 logbook	125
8.27	DR 48 date and time 2 (for Modbus).....	127
8.28	DR 59 Parameter string digital load cell.....	127
8.29	DR 70 SIWAREX DB parameter	128
8.30	DR 80 SIWAREX DB process status	129
8.31	DR 81 SIWAREX DB process status advanced.....	132
8.32	DR 82 SIWAREX DB device information	133
9	Messages	135
9.1	Message types	135
9.2	Message paths.....	135
9.3	Evaluating messages with the help of SIWATOOL.....	136
9.4	Evaluating messages with the help of the SIMATIC FB.....	136
9.5	Message list	136
9.5.1	System status message list.....	136
9.5.2	Technology error message list.....	137
9.5.3	Data and operating errors message list	137
9.5.4	Messages by LEDs on the module	139
10	Command lists	141
10.1	Overview	141
10.2	Command lists	141
10.3	Command groups of the electronic weighing system.....	146

11	Communication	147
11.1	Integration in SIMATIC S7-1200	147
11.1.1	General information.....	147
11.1.2	Operation on S7-1200 failsafe controllers.....	148
11.1.3	Creating the hardware configuration	148
11.1.4	Calling of function block	150
11.1.5	Working with the function block.....	151
11.1.6	I/O interface of function block.....	153
11.1.7	Error codes of function block.....	153
11.2	Communication via Modbus.....	154
11.2.1	General information.....	154
11.2.1.1	Principle of data transmission	154
11.2.1.2	Data record concept.....	155
11.2.1.3	Command mailboxes	156
11.2.1.4	Reading registers	156
11.2.1.5	Writing registers	157
12	Operation requiring verification	159
12.1	Preparing for verification	159
12.1.1	Calibration set	159
12.1.2	Scale design.....	159
12.1.3	Installation and parameterization of the main SecureDisplay for legal trade in the HMI.....	159
12.1.4	Parameterization of the scale.....	160
12.1.5	Adjustment and preliminary checking of the scale	160
12.1.6	Calibration label	160
12.2	Verification	160
12.2.1	Checking of parameters relevant to the verification	160
12.2.2	Checking of parameters relevant to the device.....	162
13	Technical data	165
13.1	Electrical, EMC and climatic requirements.....	169
13.2	Approvals	173
14	Ordering data	175
A	Product documentation and support	177
A.1	Product documentation	177
A.2	Technical support.....	177
B	ESD guidelines	179
B.1	ESD Guidelines.....	179
C	Abbreviations	181
	Index	183

Introduction

1.1 Purpose of this documentation

These instructions contain all information required to commission and use the device. Read the instructions carefully prior to installation and commissioning. In order to use the device correctly, first review its principle of operation.

The instructions are aimed at persons mechanically installing the device, connecting it electronically, configuring the parameters and commissioning it, as well as service and maintenance engineers.

1.2 Use in hazardous area

 WARNING
Use in hazardous area
Risk of explosion.
<ul style="list-style-type: none"> • Only use equipment that is approved for use in the intended hazardous area and labeled accordingly. • Do not use devices that have been operated outside the conditions specified for hazardous areas. If you have used the device outside the conditions for hazardous areas, make all Ex markings unrecognizable on the nameplate.

 WARNING
Incorrect installation
Risk of explosion in the hazardous area. For use in hazardous areas according to Class I, Division 2 or Class I, Zone 2 or for use in the EU according to ATEX 2014/34/EU, observe the following conditions:
<ul style="list-style-type: none"> • Install the device in a control cabinet or enclosure. • The control cabinet or enclosure meets at least the requirements of IP54 according to IEC/EN 60079-7 and pollution degree 2 or better according to IEC/EN 60664-1.

 WARNING
If the device is installed in a cabinet, the inner temperature of the cabinet corresponds to the ambient temperature of the device.

 WARNING
Opening the device
DO NOT OPEN WHEN ENERGIZED.

 WARNING
Replacing components
EXPLOSION HAZARD
SUBSTITUTION OF COMPONENTS MAY IMPAIR SUITABILITY FOR CLASS I, DIVISION 2 OR ZONE 2.

 WARNING
Impermissible repair of the device
<ul style="list-style-type: none"> Repair must be carried out by Siemens authorized personnel only.

1.3 Document history

The most important changes in the documentation when compared with the respective previous edition are given in the following table.

Manual edition	Note
06/2020	ATEX information revised
08/2019	Information on SIWAREX DB added

1.4 Product compatibility

The following table describes compatibility between manual edition, device revision, and the engineering system.

Manual edition	Comment	Device revision	Engineering system
06/2020	New characteristics	FW: 3.2.0 or higher HW: FS 1 or higher	STEP 7 TIA Portal V15.1 or higher
08/2019	New characteristics	FW: 3.2.0 or higher HW: FS 1 or higher	STEP 7 TIA Portal V15.1 or higher

1.5 Checking the consignment

1. Check the packaging and the delivered items for visible damages.
2. Report any claims for damages immediately to the shipping company.
3. Retain damaged parts for clarification.
4. Check the scope of delivery by comparing your order to the shipping documents for correctness and completeness.

 WARNING
Using a damaged or incomplete device
Risk of explosion in hazardous areas.
<ul style="list-style-type: none">• Do not use damaged or incomplete devices.

1.6 Security information

Siemens provides products and solutions with industrial security functions that support the secure operation of plants, systems, machines and networks.

In order to protect plants, systems, machines and networks against cyber threats, it is necessary to implement – and continuously maintain – a holistic, state-of-the-art industrial security concept. Siemens' products and solutions constitute one element of such a concept.

Customers are responsible for preventing unauthorized access to their plants, systems, machines and networks. Such systems, machines and components should only be connected to an enterprise network or the internet if and to the extent such a connection is necessary and only when appropriate security measures (e.g. firewalls and/or network segmentation) are in place.

For additional information on industrial security measures that may be implemented, please visit

<https://www.siemens.com/industrialsecurity>.

Siemens' products and solutions undergo continuous development to make them more secure. Siemens strongly recommends that product updates are applied as soon as they are available and that the latest product versions are used. Use of product versions that are no longer supported, and failure to apply the latest updates may increase customer's exposure to cyber threats.

To stay informed about product updates, subscribe to the Siemens Industrial Security RSS Feed under

<https://www.siemens.com/industrialsecurity>.

1.7 Transportation and storage

To guarantee sufficient protection during transport and storage, observe the following:

- Keep the original packaging for subsequent transportation.
- Devices/replacement parts should be returned in their original packaging.
- If the original packaging is no longer available, ensure that all shipments are properly packaged to provide sufficient protection during transport. Siemens cannot assume liability for any costs associated with transportation damages.

NOTICE
Insufficient protection during storage
The packaging only provides limited protection against moisture and infiltration.
<ul style="list-style-type: none">• Provide additional packaging as necessary.

Special conditions for storage and transportation of the device are listed in Technical data (Page 165).

1.8 Basic knowledge required

This manual requires basic knowledge of weighing technology. When used in the SIMATIC S7-1200, basic knowledge of the SIMATIC S7-1200 automation system and the TIA Portal are required.

1.9 Notes on warranty

The contents of this manual shall not become part of or modify any prior or existing agreement, commitment or legal relationship. The sales contract contains all obligations on the part of Siemens as well as the complete and solely applicable warranty conditions. Any statements regarding device versions described in the manual do not create new warranties or modify the existing warranty.

The content reflects the technical status at the time of publishing. Siemens reserves the right to make technical changes in the course of further development.

Safety notes

2.1 General safety instructions

 WARNING

Handling of the device/system by persons other than qualified personnel or ignoring the warning instructions can result in severe injuries or damages. This means only qualified personnel are permitted to handle this device/system.

 WARNING

Commissioning is absolutely prohibited until it has been ensured that the machine in which the component described here is to be installed fulfills the regulations/specifications of Machinery Directive 89/392/EEC.

Note

The specifications of the manual for the SIMATIC S7-1200 system apply for configuration, installation and commissioning in the SIMATIC environment. This chapter includes additional information on hardware configuration, installation and preparation for operation of the SIWAREX WP231.

The safety notes must be observed.

Note

The device was developed, manufactured, tested and documented in compliance with the relevant safety standards. The device does usually not pose any risks of material damage or personal injury.

2.1 General safety instructions

Description

3.1 Product overview

SIWAREX WP231 is a versatile and flexible weighing module that can be operated as a non-automatic weighing instrument.

The electronic weighing system can be used in SIMATIC S7-1200 and uses all features of a modern automation system, such as integrated communication, operation and monitoring, the diagnostic system as well as the configuration tools in the TIA Portal.

3.2 Information about previous versions

Up to firmware version V1.0.3

Up to firmware version V1.0.3, data record communication between the electronic weighing system and the SIMATIC CPU is not possible.

As of firmware version V1.0.4

As of firmware version V1.0.4 data records can be sent from the electronic weighing system to the S7-1200 CPU and received by the electronic weighing system. Complete operation and commissioning of the scales is possible via the SIMATIC CPU or the SIMATIC HMI. The current Ready-for-Use example project must be used for this in addition to the matching firmware. This example project contains the matching SIMATIC blocks and an extended WinCC configuration.

The "ready for use" example project can be found in the configuration package or on the Internet: → SIWAREX WP231 "Ready for use" (<http://support.automation.siemens.com/WW/view/de/64722267/133100>).

As of firmware version V3.0.0

The electronic weighing system can be operated as legal for trade as of firmware version V3.0.0.

The "ready for use" example project can be found on the Internet: → SIWAREX WP231 "Ready for use" (<http://support.automation.siemens.com/WW/view/de/64722267/133100>).

As of firmware version V3.2.0

SIWAREX DB can be connected to the electronic weighing system as of firmware version V3.2.0.

The "ready for use" sample project can be found on the Internet: → SIWAREX WP231 "Ready for use" (<http://support.automation.siemens.com/WW/view/de/64722267/133100>)

3.3 Operation requiring official calibration

SIWAREX WP231 has been assigned an EC construction license for operation requiring verification in accordance with directive 2009/23/EC.

It complies with the requirements in accordance with OIML R76.

Operation requiring verification is not possible with SIWAREX DB.

3.4 Area of application

The electronic weighing system described here is the perfect solution for applications in which signals from weighing or force sensors are to be acquired and processed. The SIWAREX WP231 is a very accurate electronic weighing system.

The SIWAREX WP231 is equipped for the following applications:

- NAWI - Non-automatic weighing instrument - in accordance with OIML R76
- Fill-level monitoring of silos and hoppers
- Platform scales
- Scales in potentially explosive atmospheres (with Ex interface SIWAREX IS)

3.5 System integration in SIMATIC

The electronic weighing system described here is a technology module for SIMATIC S7-1200. It allows the user to configure all aspects of the automation solution, and weighing application, to his requirements. You can create optimal solutions for small and medium-sized plants by combining the suitable SIMATIC modules. You can create customized or industry-specific solutions in no time with the help of the configuration package available under the "Ready for use" application for SIMATIC.

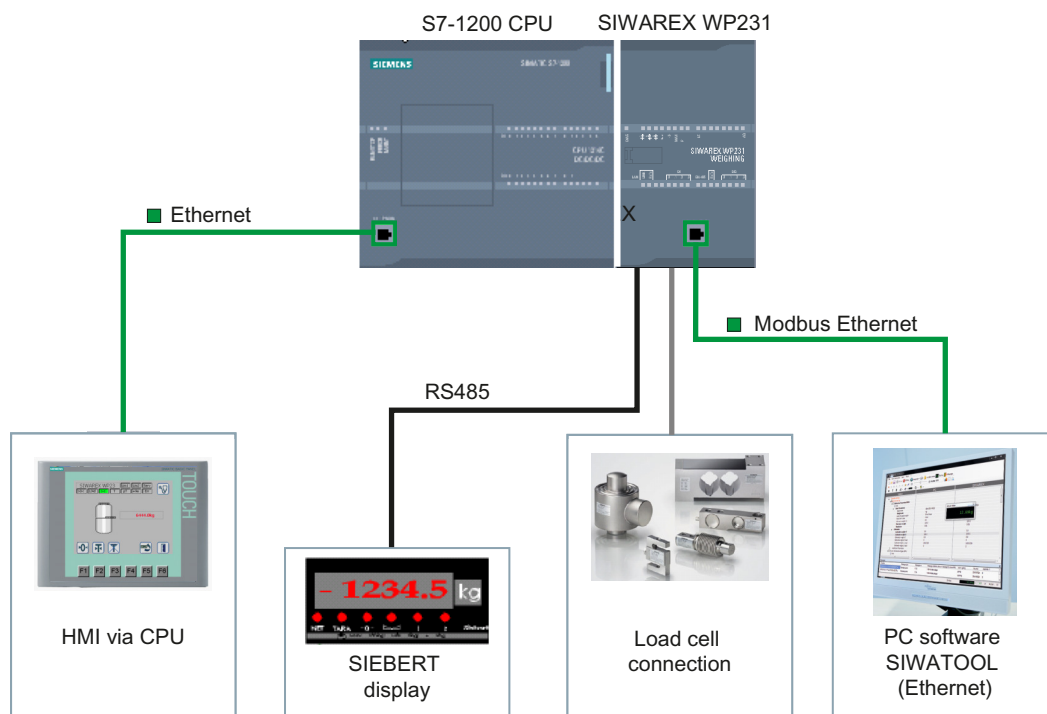

Figure 3-1 System overview

3.6 Customer benefits

The electronic weighing system described here is characterized by decisive advantages:

- Uniform design technology and consistent communication in SIMATIC S7-1200
- Parameter assignment by means of HMI panel or PC
- Uniform configuration option in the SIMATIC TIA Portal
- Measuring of weight with a resolution of up to 4 million divisions
- High accuracy, 3000 d, legal for trade according to OIML R76
- Legal-for-trade display with SIMATIC operator panel or PC
- High measuring rate of 100/120 Hz (effective interference frequency suppression)
- Limit monitoring
- Flexible adaptation to varying requirements

3.6 Customer benefits

- Easy calibration of the scales using the SIWATOOL program
- Automatic calibration is possible without the need for calibration weights
- Module replacement is possible without recalibrating the scales
- Use in Ex Zone 2 / ATEX approval
- Intrinsically safe load cell supply for Ex Zone 1 (SIWAREX IS option)
- Diagnostics functions

Application planning

4.1 Functions

The primary task of the electronic weighing system is the measurement and registration of the current weight value. The integration in SIMATIC gives you the option to process the weight value directly in the PLC (**P**rogrammabel**L**ogic **C**ontroller).

The SIWAREX WP231 is calibrated at the factory. This allows for automatic calibration of the scales without the need for calibration weights and replacement of modules without the need for recalibrating the scales.

The Ethernet interface can be used to connect a PC for parameter assignment of the electronic weighing system or for connection to any automation system (Modbus TCP/IP).

The SIWAREX WP231 electronic weighing system can also be used in potentially explosive atmospheres (Zone 2). The load cells are supplied intrinsically safe in Zone 1 applications when you use the optional Ex interface SIWAREX IS.

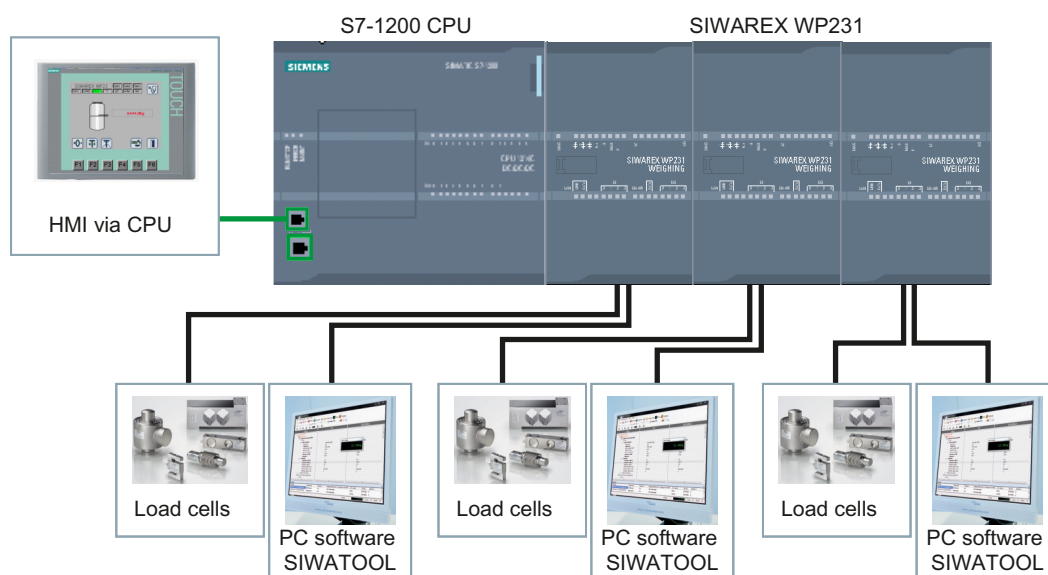

Figure 4-1 System integration in SIMATIC S7-1200

The SIWAREX WP231 can also be used in standalone mode independent of the automation system. There are many configuration options in this case.

The user can select the enclosure as well as the Operator Panel. But the Operator Panel must support Modbus RTU or TCP/IP. This means you can implement your own operating philosophy.

The SIWAREX WP231 can be controlled remotely without its own Operator Panel on site. One Operator Panel can be used for several scales. The configuration options are almost unlimited in this case.

4.2 Parameter assignment options

4.2.1 Parameter assignment with the PC

You can set the scale parameters with the convenience of the familiar Windows interface by using the "SIWATOOL" PC parameter assignment software.

You can use the program for commissioning the scale without any knowledge of automation technology. When servicing is required, you can analyze and test the processes in the scale independently of the automation system or Operator Panel with the help of the PC. You can read out the diagnostic buffer from the SIWAREX module to assist you in the event analysis.

The figure below illustrates the structure of the individual program windows.

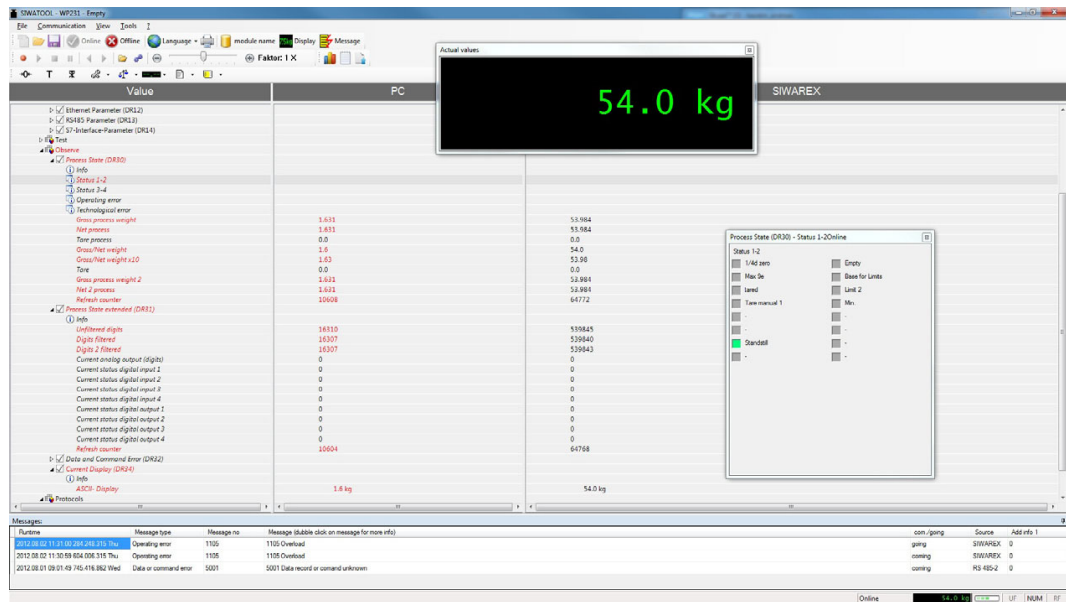

Figure 4-2 SIWATOOL overview

SIWATOOL does not only offer support when you set the scale but also when you analyze the diagnostic buffer that can be saved after being read out of the module together with the parameters. The display of the current scale status can be configured.

You can switch between several languages in the program.

4.2.2 Parameter assignment with a SIMATIC Panel

All parameters can be assigned and the module put into operation using a SIMATIC HMI Panel connected to the S7-1200 CPU and the SIWAREX WP231 function and data blocks.

The Ready-for-Use software is included in the scope of delivery of the configuration package. This includes the Step7 program for the CPU and the HMI project for scale visualization. Further information on integration in the TIA Portal can be found in chapter → Integration in SIMATIC S7-1200 (Page 147).

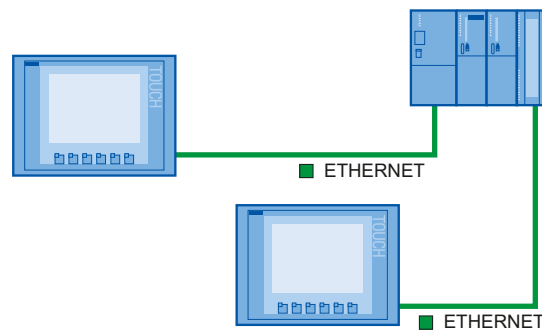

Figure 4-3 Configuration of the SIMATIC CPU with two Operator Panels

4.2.3 Parameter assignment by means of the Modbus interface

Alternatively, the SIWAREX module can also be configured and operated directly over a SIMATIC Panel. The SIMATIC Panel communicates directly with the SIWAREX module over MODBUS TCP/IP in this case. The SIWAREX module behaves like a Modbus slave in this case. The scope of delivery of the configuration package includes a downloadable HMI software for a SIMATIC Panel TP700 Comfort. Additional Example projects available for free download (<https://support.industry.siemens.com/cs/ww/de/ps/17797/dl>).

All SIMATIC HMI Comfort Panels can be used for direct Modbus communication. The use of SIMATIC Basic Panels 1st Generation is not possible. When using SIMATIC Basic Panels 2nd Generation, install the Communication Service Package (<https://support.industry.siemens.com/cs/ww/en/view/109739698>). A direct connection between a SIMATIC HMI Panel and SIWAREX WP over Modbus RTU has not been approved.

The parameters for the SIWAREX module can also be prepared in a third-party system and transmitted to the electronic weighing system by means of Modbus RTU or TCP/IP. A detailed description of the assignment of the holding registers can be found in section "Scale parameters and functions (Page 65)".

Mounting

5.1 Basic safety notes

5.1.1 ATEX Special conditions for use

 WARNING
Incorrect installation
Risk of explosion in the hazardous area. For use in hazardous areas according to Class I, Division 2 or Class I, Zone 2 or for use in the EU according to ATEX 2014/34/EU, observe the following conditions:
<ul style="list-style-type: none">• Install the device in a control cabinet or enclosure.• The control cabinet or enclosure meets at least the requirements of IP54 according to IEC/EN 60079-7 and pollution degree 2 or better according to IEC/EN 60664-1.

Note

You must not install the device on a wall in hazardous areas.

 WARNING
Transient overvoltages
Take measures to ensure that temporary transient overvoltages of more than 119 V do not occur.

5.2 Installation guideline

When installing the SIMATIC components together with the electronic weighing system described here, the setup, installation and wiring guidelines for the SIMATIC S7-1200 must be observed (see system manual "SIMATIC S7 S7-1200 automation system", order no.: A5E02486681).

This manual describes additional installation and wiring aspects specific to the electronic weighing system.

5.3 EMC-compliant setup

5.3.1 Introduction

Overview

The electronic weighing system described here was developed for use in industrial environments and complies with high EMC requirements. Nevertheless, before installing your devices you should prepare an EMC plan and identify and take into consideration possible interference sources.

EMC

EMC (electromagnetic compatibility) describes the capability of electrical equipment to operate without errors in a given electromagnetic environment, without being subject to external influence and without influencing external devices in any way.

5.3.2 Possible effects of interference

Electromagnetic interferences can influence the electronic weighing system described here in various ways:

- Electromagnetic fields having a direct influence on the system
- Interferences transported by communication cables
- Interferences having an effect via process cables
- Interferences entering the system via the power supply and/or protective ground

Interferences can impair the fault-free functioning of the electronic weighing system.

5.3.3 Coupling mechanisms

Depending on the propagation medium (conducted or non-conducted) and the distance between the interference source and the device, interferences can enter the faulty device through four different coupling mechanisms:

- Electrical coupling
- Capacitive coupling
- Inductive coupling
- Radiation coupling

5.3.4 Five basic rules for securing EMC

Observe these five basic rules to secure EMC.

Rule 1: Large area grounding contact

- When installing the devices, make sure that the surfaces of inactive metal parts are properly bonded to chassis ground (see following sections).
- Bond all inactive metal parts to chassis ground, ensuring large area and low-impedance contact (large cross-sections).
- When using screw connections on varnished or anodized metal parts, support contact with special contact washers or remove the protective insulating finish on the points of contact.
- Wherever possible, avoid the use of aluminum parts for ground bonding. Aluminum oxidizes very easily and is therefore less suitable for ground bonding.
- Provide a central connection between chassis ground and the ground/protective conductor system.

Rule 2: Proper cable routing

- Organize your wiring system into cable groups (high-voltage/power supply/signal/measurement/data cables).
- Always route high-voltage and data cables in separate ducts or in separate bundles.
- Install the measurement cables as close as possible to grounded surfaces (e.g. supporting beams, metal rails, steel cabinet walls).

Rule 3: Fixing the cable shielding

- Ensure proper fixation of the cable shielding.
- Always use shielded data cables. Always connect both ends of the data cable shielding to ground on a large area.
- Keep unshielded cable ends as short as possible.
- Always use metal/metalized connector housings only for shielded data cables.

Rule 4: Special EMC measures

- All inductors that are to be controlled should be connected with suppressors.
- For cabinet or enclosure lighting in the immediate range of your controller, use incandescent lamps or interference suppressed fluorescent lamps.

Rule 5: Homogeneous reference potential

- Create a homogeneous reference potential and ground all electrical equipment.
- Use sufficiently dimensioned equipotential bonding conductors if potential differences exist or are expected between your system components. Equipotential bonding is absolutely mandatory for applications in hazardous areas.

5.4 Mounting on the SIMATIC S7-1200

The electronic weighing system described here is a SIMATIC S7-1200 module and can be directly connected to the automation system's bus system. The 70 mm wide module has very low installation and cabling requirements.

The module is fitted on a mounting rail, and the bus connection made using the slide switch.

The load cells, power supply and serial interfaces are connected via the screw-type connectors.

Use of the WP231 in the SIMATIC TIA Portal is described in detail in cc 11 of this manual: → Integration in SIMATIC S7-1200 (Page 147)

Connecting

6.1 Basic safety notes

6.1.1 ATEX Special conditions for use

 WARNING
WARNING – EXPLOSION HAZARD: DO NOT CONNECT OR DISCONNECT EQUIPMENT WHEN A FLAMMABLE OR COMBUSTIBLE ATMOSPHERE IS PRESENT.

 WARNING
Transient overvoltages Take measures to ensure that temporary transient overvoltages of more than 119 V do not occur.

6.2 Overview

All external connections (with the exception of the Ethernet interface) are made by means of the screw connectors (terminal block 1 to 4).

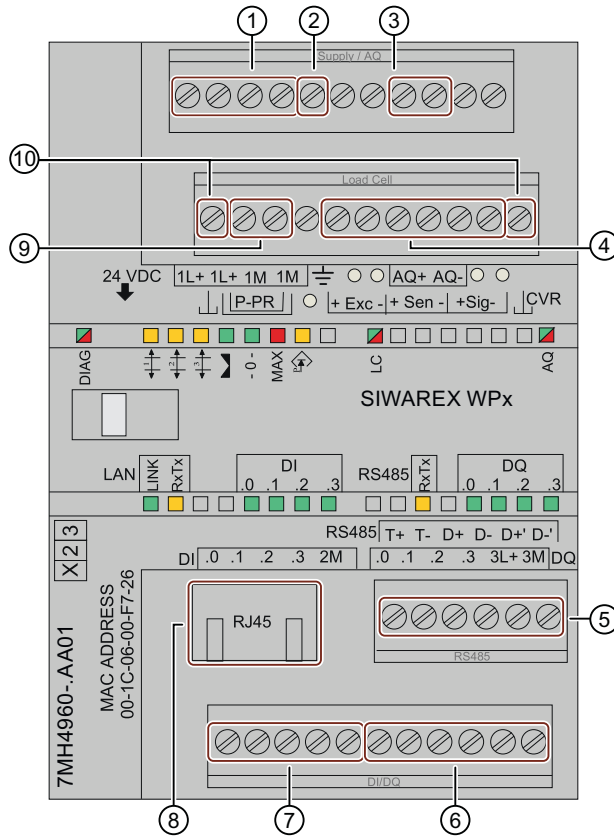

- | | |
|-----------------------------------|---|
| ① 24 V connection | ⑥ Digital output connection |
| ② Functional grounding connection | ⑦ Digital input connection |
| ③ Analog output connection | ⑧ Ethernet interface connection |
| ④ Load cell connection | ⑨ Calibration bridge connection |
| ⑤ RS485 interface connection | ⑩ Mounting terminals for the calibration protection plate |

Figure 6-1 Connection areas

6.3 24 V connection

The 24 V DC supply voltage is connected by means of the corresponding terminals on the electronic weighing system.

Table 6-1 Connection of the 24 V supply

Labeling	Function
L +	+24 V voltage supply
M	Ground voltage supply
\perp	Functional grounding (grounded DIN rail)

6.4 Connection of analog load cells

Sensors equipped with expansion measuring strips (EMS) can be connected to the electronic weighing system. These sensors meet the requirements in section Technical data (Page 165).

6.4.1 Connecting SIWAREX JB to the electronic weighing system and load cell

Procedure

1. Open the cover of the SIWAREX JB.
2. Screw in an M16 x 1.5 cable gland for each load cell.
3. Screw in an M20 x 1.5 EMC cable gland for the signal cable to the electronic weighing system.
4. Wire the SIWAREX JB to the load cell and the electronic weighing system in accordance with Wiring diagrams (Page 32).
To learn how to connect the cable, see section Connecting the cable (Page 34).
5. Close any unused opening in the enclosure with a blanking plug.
6. Connect the equipotential bonding conductor to the outside of the enclosure.
Use shielded cable lugs.
7. Close the cover of the SIWAREX JB according to the tightening torque.

6.4.2 Wiring diagrams

6.4.2.1 Load cells with four-wire system

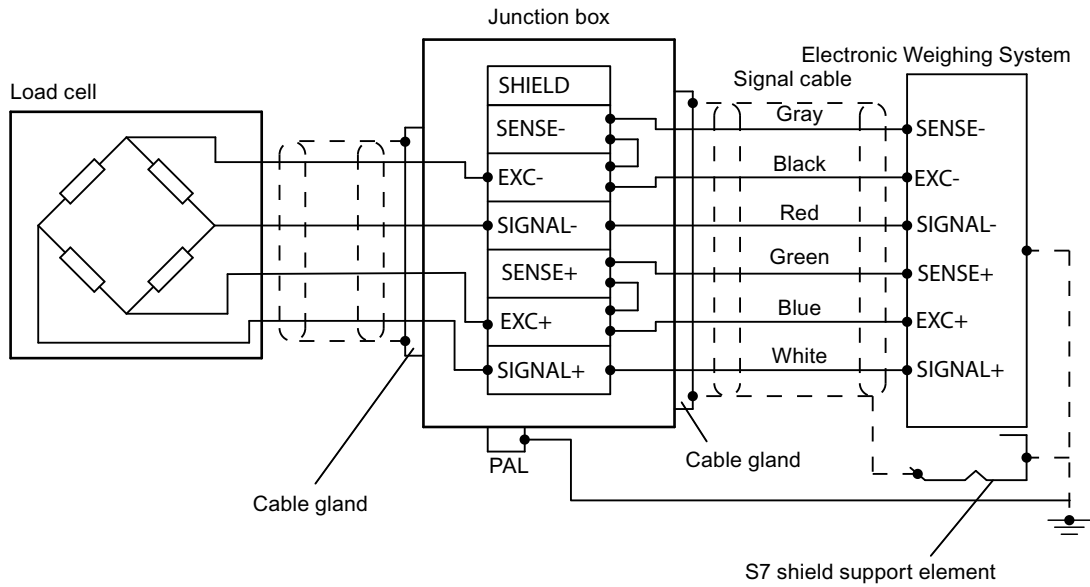

Figure 6-2 Cable shield of the signal cable connected to EMC cable gland

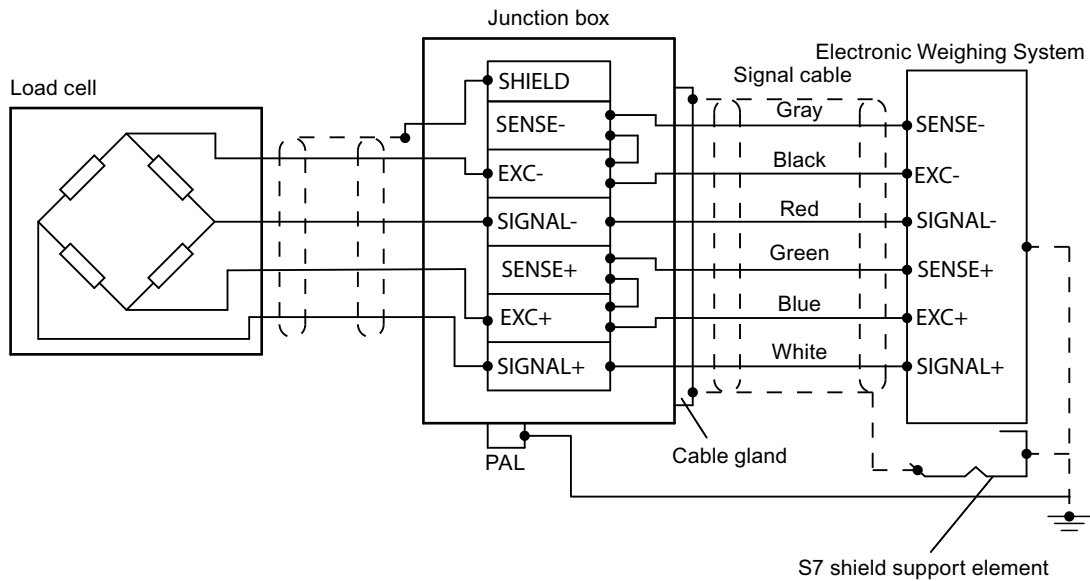

Figure 6-3 Cable shield of the signal cable connected to shield terminal

The following wire jumpers are set by default:

Wire jumper	From terminal	To terminal
1	EXC-	SENSE-
2	EXC+	SENSE+

Note

If the wire jumpers are missing, the electronic weighing system reports a wire break.

6.4.2.2 Load cells with six-wire system

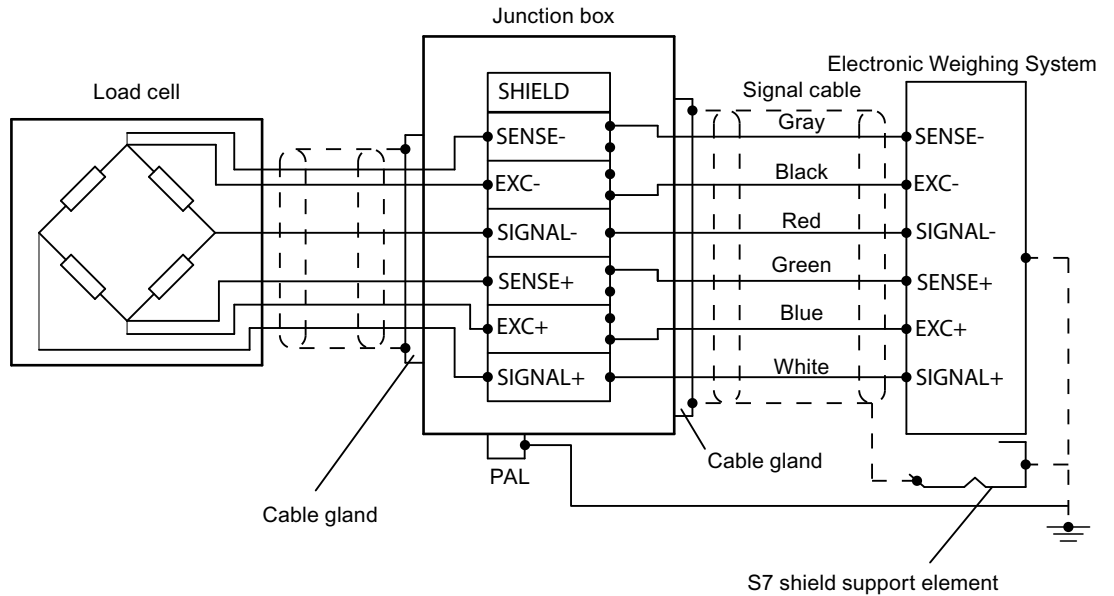

Figure 6-4 Cable shield of load cell cable connected to EMC cable gland

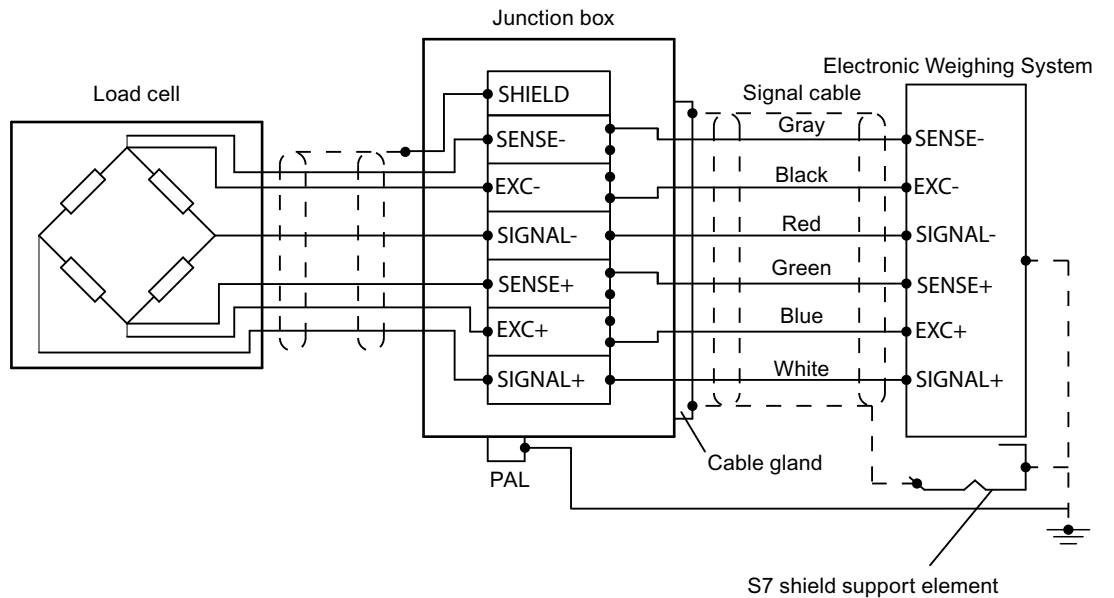

Figure 6-5 Cable shield of load cell cable connected to shield terminal

- Disconnect the following wire jumpers:

Wire jumper	From terminal	To terminal
1	EXC-	SENSE-
2	EXC+	SENSE+

6.4.3 Connecting the cable

Requirement

You require a screwdriver with a maximum blade width of 3.5 mm.

Procedure

1. In EMC cable glands, lay the cable shielding over a large area.

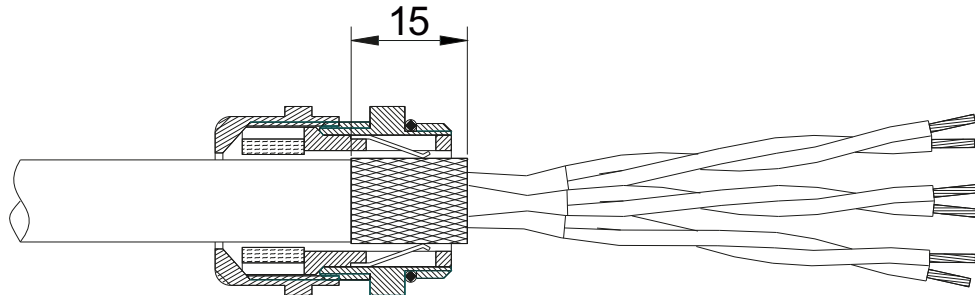

Figure 6-6 Place the cable shield in the EMC cable gland

2. With plastic cable glands, place the corresponding wire of the SIWAREX load cell on the shield terminal.
3. Strip at least 6 mm of insulation from the load cell cable.

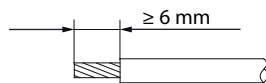

Figure 6-7 Strip cable

4. Insert the stripped load cell cable into the square opening of the screw terminal as far as it will go.
5. Tighten the screws with the specified tightening torque.

Result

The tightened screw firmly holds the stripped wire and establishes the contact.

6.5 Shield connection

Make sure you observe the correct design of the shield support for the shielded cables. It is the only way to ensure immunity of the system.

A cable is shielded to attenuate the effects of magnetic, electrical and electromagnetic interference on the cable. Interference currents on cable shielding are diverted to ground by conductive isolation rails. To avoid interference as a result of these currents, it is imperative to provide a low-impedance connection to the ground.

Use only cables with protective braided shield (see recommended cables of digital load cells in chapter Ordering data (Page 175)). Shielding density must be at least 80%.

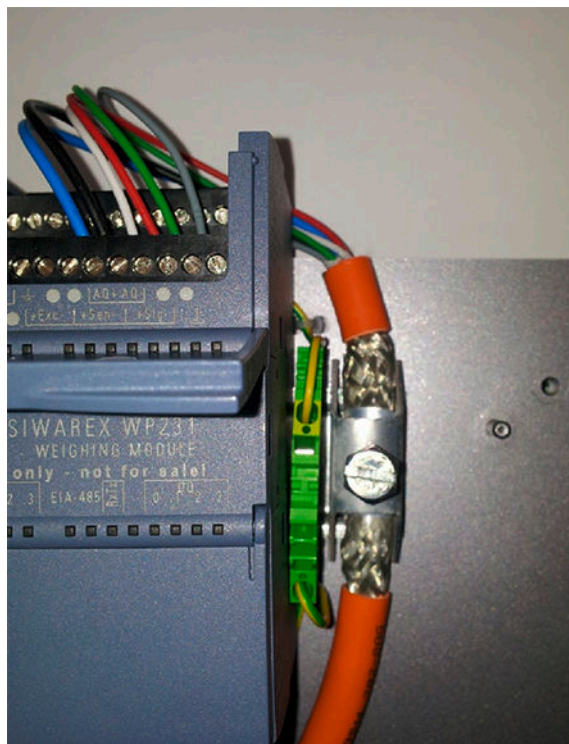

Figure 6-8 Shield connection element fitting (example)

6.6 Connection of digital outputs (4 x DQ)

⚠ CAUTION

Unknown assignment of digital outputs

The assignment of the digital outputs is not known at the time of connection. Digital outputs can be active immediately after turning on the power supply. This may damage parts of the system.

Do not create a connection with the digital outputs before you know the assignment of the digital outputs.

The electronic weighing system described here has four digital outputs. They are not permanently assigned to process values in the delivery state. Assignment of these digital outputs to functions as well as definition of the response in the event of a fault is carried out

6.7 Connection of digital inputs (4 x DI)

during commissioning by parameter assignment of data record 7. The 24 V power supply for the digital outputs is provided via terminals 3L+ and 3M with electrical isolation.

Table 6-2 Connection of the digital outputs

Labeling	Function
DQ.0	Digital output 0
DQ.1	Digital output 1
DQ.2	Digital output 2
DQ.3	Digital output 3
DQ.3L+	+24 V DC power supply for digital outputs
DQ.3M	Ground of power supply for digital outputs

6.7 Connection of digital inputs (4 x DI)

<p> CAUTION</p> <p>Unknown assignment of digital inputs</p> <p>If the assignment of the digital inputs is not known at the time of connection, this may damage parts of the system.</p> <p>Do not create a connection with the digital inputs before you know the assignment.</p>
--

The electronic weighing system described here has four digital inputs. The digital inputs are not permanently assigned to commands in the delivery state. Assignment of the digital inputs to commands is carried out during commissioning by parameter assignment of data record 7. The external 24 V switching signal is connected electrically isolated to the desired input, the associated ground to terminal 2M.

Table 6-3 Connection of the digital inputs

Labeling	Function
DI.0	Digital input 0
DI.1	Digital input 1
DI.2	Digital input 2
DI.3	Digital input 3
DI.2M	Reference ground potential of the digital inputs

6.8 Connection of the analog output (1 x AQ)

⚠ CAUTION
Unknown assignment of the analog outputs
The assignment of the analog output is not known at the time of connection. The analog output can be active immediately after turning on the power supply. This may damage parts of the system.
<ul style="list-style-type: none"> Do not create a connection with the analog output before you know the assignment.

The analog output is not permanently assigned to a process value in the delivery state. Assignment of the analog output to the process value as well as its response in the event of a fault is carried out during commissioning in data record 7. If a wire break occurs, the LED labeled "AQ" flashes red. The output can be configured as 0 to 20 mA or 4 to 20 mA output.

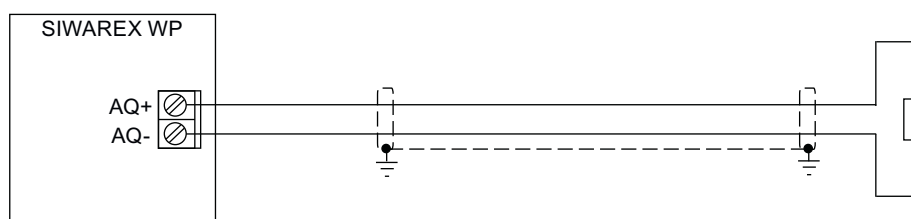

Figure 6-9 Analog output connection

6.9 Connection of RS485 serial interface

Devices can be connected to the serial interface RS485 in accordance with the information in section Technical data (Page 165)

Table 6-4 Connection of RS485 serial interface

Labeling	Function
EIA-485 T+	RS485 termination +
EIA-485 T-	RS485 termination -
EIA-485 D+'	RS485 data line +' for looping through of bus signal
EIA-485 D-'	RS485 data line -' for looping through of bus signal
EIA-485 D+	RS485 data line + for feeding in of bus signal
EIA-485 D-	RS485 data line - for feeding in of bus signal

If the electronic weighing system forms the termination of an RS485 network, insert wire jumpers between the D+' and T+ terminals and between the D- and T- terminals for termination of the bus network.

6.10 Connection of Siebert display via RS485

A Siebert display S102 with the order no. S102-W6/14/0R-000/0B-SM can be connected to the RS485 interface of the weighing module. Connect a 24 V DC supply to the Siebert display. Connect the latter to the RS485 interface of the weighing module as shown in the figure below.

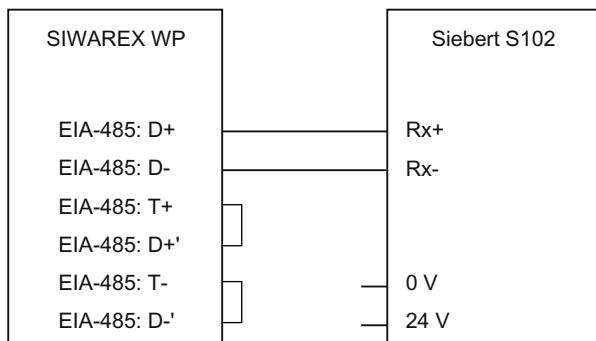

Figure 6-10 Connection of Siebert display S102

The RS485 interface in the DR 13 of the SIWAREX WP is set as follows:

- Baud rate: 9600 bps
- Character parity: Even
- Number of data bits: 8
- Number of stop bits: 1

The S102 is set as follows:

Table 6-5 Settings of Siebert display S102

Menu item	Setting	Meaning
1 Interface	485	RS485 interface
9 Station address	01	Address meaning:
		Address Weight value
		01 Verifiable weight
		02 Total
		03 Net
04 Tare		
t Timeout	2	e.g. timeout after 2 seconds
C	0.0	No decimal point
F Segment test	----*	No segment test when switching on
	8.8.8	Segment test when switching on

6.11 Connection of digital load cells from the Wipotec company

You can connect a Wipotec load cell for which the "SIWAREX protocol" and firmware FS911 V1.690 or FS276 V3.560 or higher is set to the RS485 interface.

The electronic weighing system communicates with the load cell through a point-to-point connection via RS485/RS422.

6.11.1 Electrical connection of load cells with plug-in connection

Make the following wiring between the load cell and the electronic weighing system:

Electronic weighing system terminals	Load cell terminals	Comment
T+	-	Jumper to D+'
T-	-	Jumper to D-'
D+'	2	RS422 positive send line
D-'	4	RS422 negative send line
D+	1	RS422 positive reception line
D-	6	RS422 negative reception line
1L+	7	Supply voltage 24 V DC
1M	3	Supply voltage M
\perp	8	Protective ground

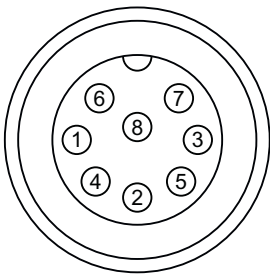
Terminals of the cable of the digital load cell	SIGNAL	Designation	Connector 1
1	RX+	RS422 pos. receive line	
2	Tx+	RS422 pos. send line	
3	GND	Reference potential supply	
4	TX-	RS422 negative send line	
5	(EIN 1)	Binary input (optional)	
6	RX-	RS422 negative reception line	
7	24 V DC	Supply voltage	
8	PE	Protective ground	
			Cable digital load cell

6.11.2 Electrical connection of load cells with terminal block (SW-D-FS series)

Make the following wiring between the load cell and the electronic weighing system:

Load cell Terminal block X1	SIGNAL	Connection to electronic weighing system
1	Current transfer channel 7 ³⁾	
2	Current transfer channel 6 ³⁾	
3	Current transfer channel 2 ³⁾	
4	Current transfer channel 1 ³⁾⁴⁾	

6.11 Connection of digital load cells from the Wipotec company

Load cell Terminal block X1	SIGNAL	Connection to electronic weighing system
5	0 V supply voltage weighing sensor ¹⁾	1M
6	24 V supply voltage weighing sensor ¹⁾	1L+
7	24 V supply voltage weighing sensor ¹⁾	
8	0 V supply voltage weighing sensor ¹⁾	
9	Binary input 1 ³⁾	
10	Binary input 2 ³⁾	
11	Binary input 3 ³⁾	
12	Binary input 4 ³⁾	
13	Binary output 1 ³⁾	
14	Binary output 2 ³⁾	
15	Binary output 3 ³⁾	
16	Binary output 4 ³⁾	

1) The signal/potential is live on the two clamping points for distribution purposes. The two clamping points are equivalent.

3) Option

4) Internally connected to the enclosure

Load cell terminal block X2	SIGNAL	RS422	CAN	Connection to electronic weighing system
1	Current transfer channel 4 ^{1) 3)}			
2	Current transfer channel 4 ^{1) 3)}			
3	Current transfer channel 3 ^{1) 3)}			
4	Current transfer channel 3 ^{1) 3)}			
5	Current transfer channel 5 ³⁾			
6	Interface 1 ²⁾	RX-	CANGND	D-
7	Interface 1 ²⁾	RX+	--	D+
8	Interface 1 ²⁾	--	CANL ¹⁾	
9	Interface 1 ²⁾	TX-	CANL ¹⁾	D-'
10	Interface 1 ²⁾	TX+	CANH ¹⁾	D+'
11	Interface 1 ²⁾	--	CANH ¹⁾	
12	Interface 2: GND2			
13	Interface 2: TxD			
14	Reserve			
15	Interface 2: RxD			
--	--			

1) The signal/potential is live on the two clamping points for distribution purposes. The two clamping points are equivalent.

2) Interface 1 can be optionally fitted ex factory as RS422 or CAN.

3) Option

6.12 Connection of digital load cells from the Mettler-Toledo company

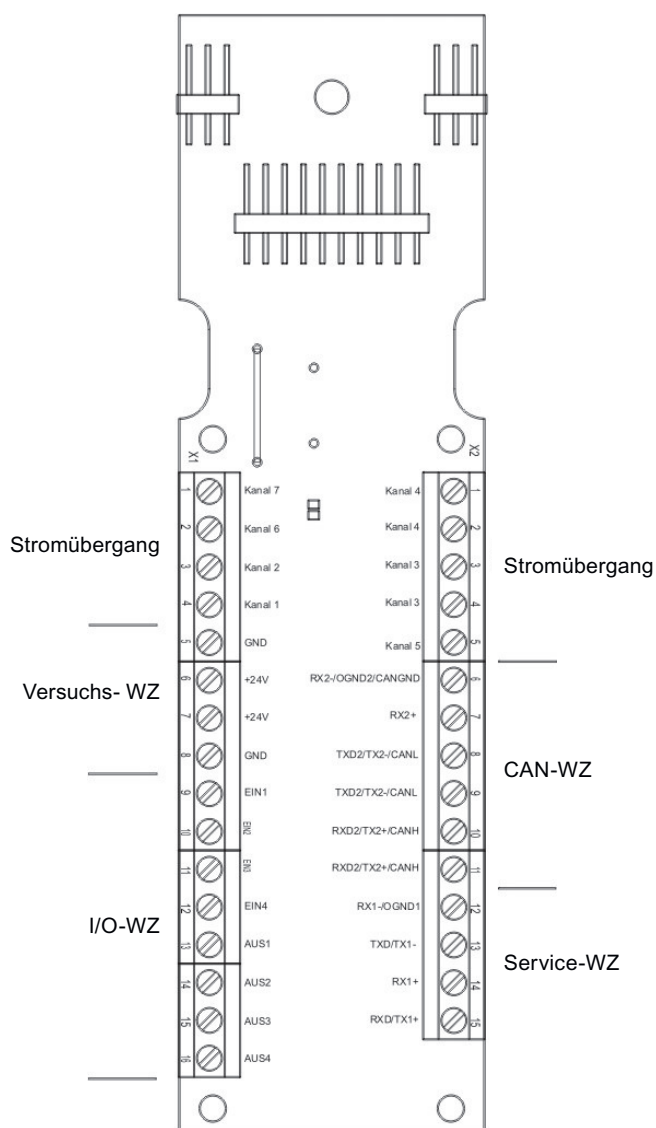

Figure 6-11 Connecting load cells with terminal block

6.12 Connection of digital load cells from the Mettler-Toledo company

You can connect the digital Mettler-Toledo load cells, WMS and WMH and PBK9-APW and PFK9-APW, to the RS485 interface.

Connect the Mettler-Toledo TYPE WM and WHM with the RS485 interface of the electronic weighing system as shown in the following figure.

6.12 Connection of digital load cells from the Mettler-Toledo company

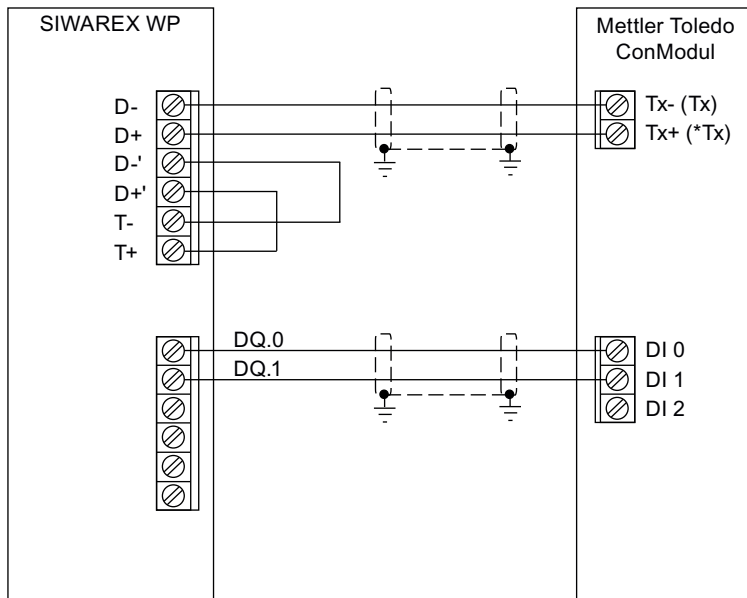

Figure 6-12 Connecting SIWAREX WP to Mettler Mettler-Toledo ConModul

The Mettler configuration software of the sensor is used to set application-dependent scale and sensor parameters.

For communication with the electronic weighing system, make the following settings (per command) at the load cell:

- PROT_2 (framework protocol)
- COM_1_8_0_0 (RS422 interface, 38400 baud, 7 bits, even parity, 1 stop bit)

Setting the digital inputs:

- DIN1_SIR_0_1 (input 1 for the SIR command, positive edge, output via RS422)
- DIN1_SI_0_1 (input 1 for the SIR command, positive edge, output via RS422)

Connect the Mettler-Toledo TYPE PBK9-APW and PFK9-APW with the RS485 interface of the electronic weighing system as shown in the following figure.

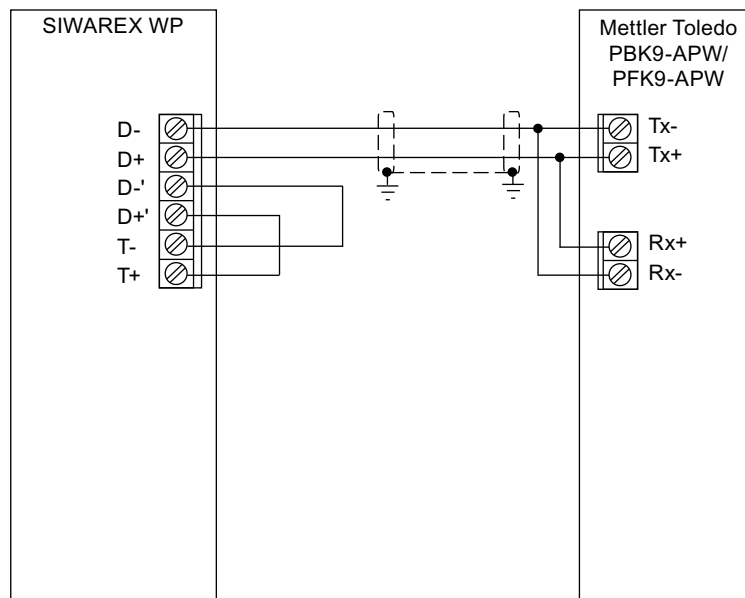

Figure 6-13 Connecting SIWAREX WP to Mettler Toledo PBK9-APW/PFK9-APW

The Mettler configuration software of the sensor is used to set application-dependent sensor parameters.

For communication with the electronic weighing system, make the following settings (per command) at the load cell:

- COM_1_8_0_0 (RS422 interface, 38400 baud, 7 bits, even parity, 1 stop bit)

6.13 Connection of the SIWAREX DB

6.13.1 Connect SIWAREX DB to SIWAREX WP electronic weighing system and load cell

Procedure

1. Open the cover of the SIWAREX DB.
2. Screw in an M16 x 1.5 cable gland for each load cell.
3. Screw in an M20 x 1.5 EMC cable gland for the signal cable to the SIWAREX WP electronic weighing system.

6.13 Connection of the SIWAREX DB

4. Attach the cables from SIWAREX DB to the load cell and the SIWAREX WP electronic weighing system.
Connect the cable (Page 45)

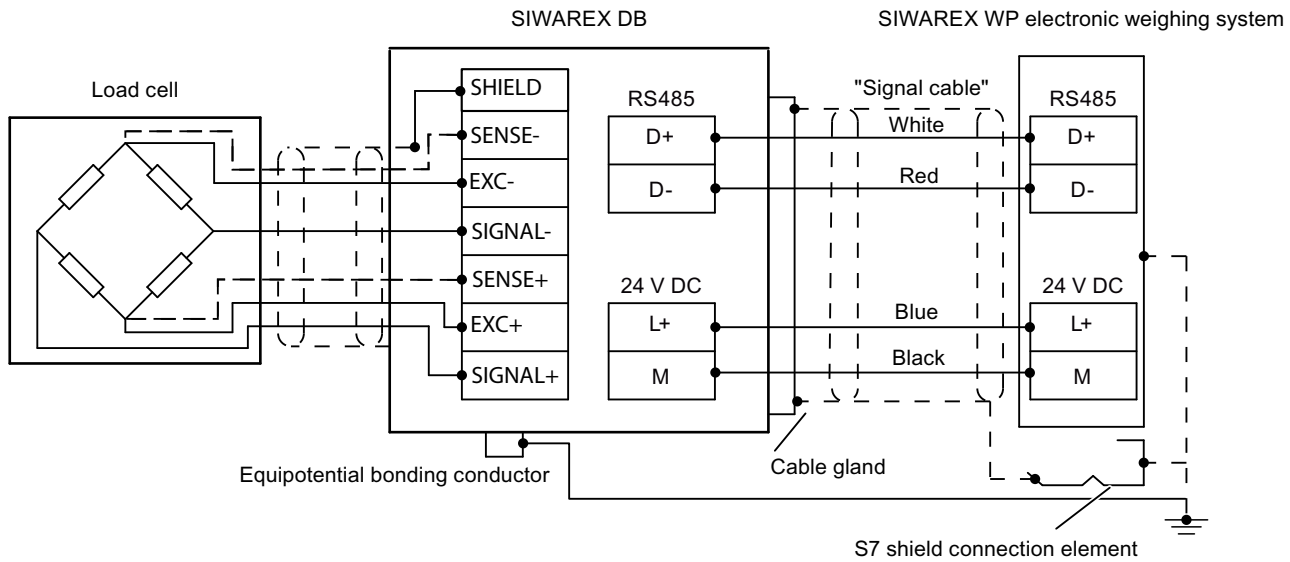
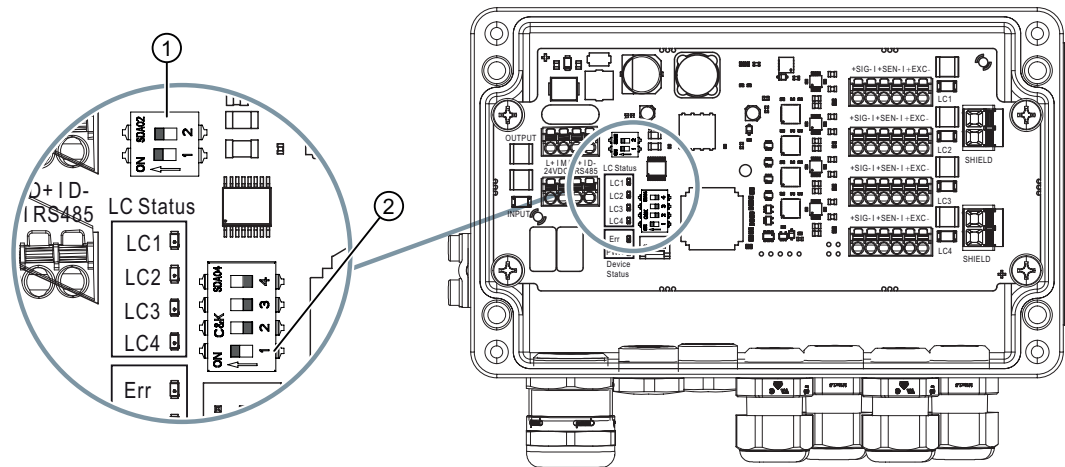

Figure 6-14 Connect SIWAREX DB to SIWAREX WP electronic weighing system and load cell

5. Activate the terminating resistor RS-485 ① by setting both DIP switches to ON.
6. Set the RS485 address by setting the DIP switch 1 ② to ON.



7. Close any unused opening in the enclosure with a blanking plug.
8. Connect the equipotential bonding conductor (functional grounding) to the enclosure exterior.
Use shielded cable lugs.
9. Close the cover of the SIWAREX DB according to the tightening torque 1.5 to 2 Nm.

6.13.2 Connect the cable

Condition

You require a screwdriver with a maximum blade width of 2.5 mm.

You can use the SIWAREX cable for supply voltage and RS-485 communications. Ordering data (Page 175)

Procedure

1. Place the cable shield in the EMC cable gland over a large area.

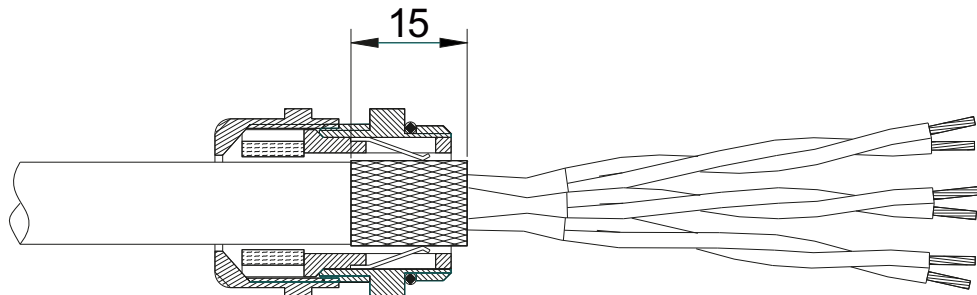

Figure 6-15 Place the cable shield in the EMC cable gland.

2. For plastic cable glands, connect the corresponding wire of the SIWAREX load cell to the shield terminal.
3. Strip the cable ends at least 6 mm.
4. Push the screwdriver into the rectangular opening of the terminals.
5. Insert the stripped cable into the round opening as far as it will go.
6. Remove the screwdriver from the rectangular opening.

6.14 Connection of the Ethernet interface

An RJ45 connector is used for the connection.

The following devices can be connected to the Ethernet interface:

- PC with SIWATOOL service and commissioning program
- Operator panels or other HMI devices with Ethernet and Modbus protocol TCP/IP
- Communication partner with Modbus protocol TCP/IP

6.15 Activation of write protection

In the case of an officially verified SIWAREX WP231, write protection must be provided to prevent the changing of data relevant to the calibration. Insert a wire jumper between the module terminals P and PR for this purpose.

Table 6-6 Activation of write protection

Labeling	Function
P	P terminal for activation of write protection
PR	PR terminal for activation of write protection

6.16 Mounting of the calibration protection plate

In order to operate SIWAREX WP231 with verification capability, the load cell connections must be protected against manipulation. To achieve this, mount the calibration protection plate included in the calibration set as shown in the following picture. Subsequently secure the calibration protection plate using the associated terminals (see Overview (Page 30)).

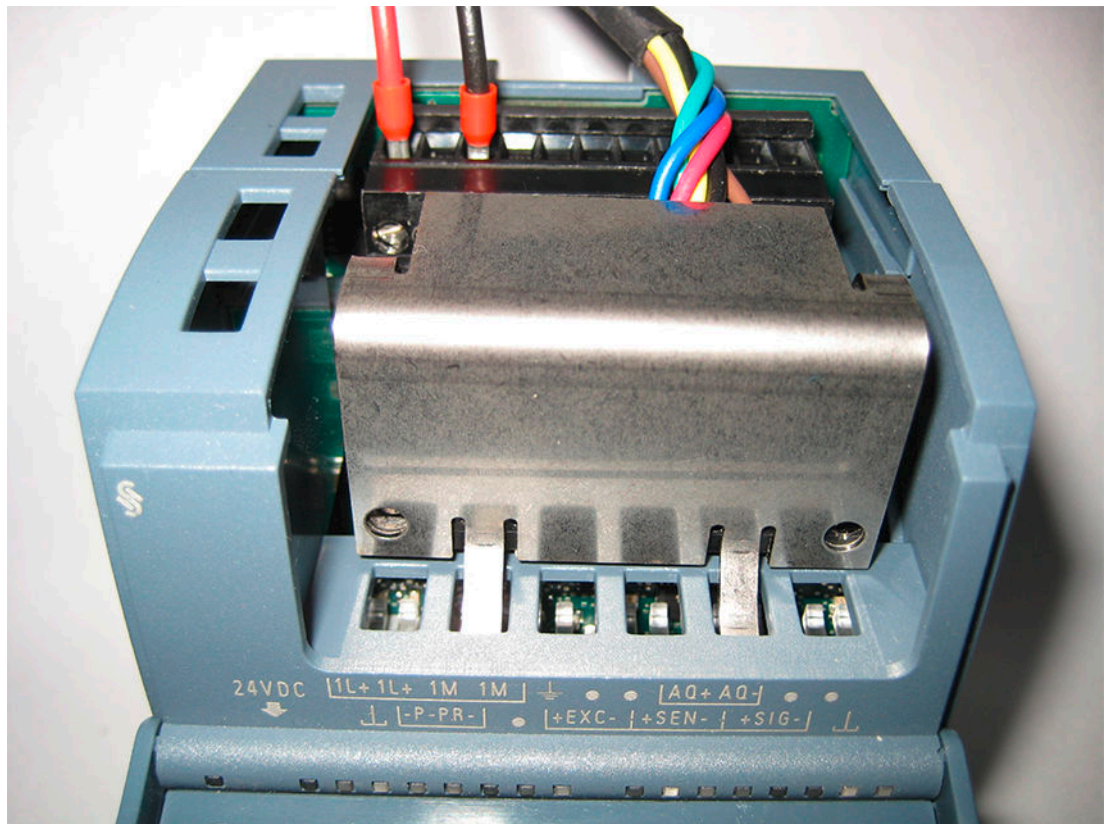

Figure 6-16 Mounting of the calibration protection plate

Commissioning

7.1 Introduction

Commissioning consists mainly of checking the mechanical scale structure, setting parameters, calibration, and verification of the envisaged functionality.

7.2 Factory-set parameters

The electronic weighing system described here is provided with factory-set parameters. The parameters have been provided for a typical 100 kg scale based on three load cells. Parameters which can be entered in % or time are preset in such a way that they provide good results for most applications.

With these default parameters, commissioning can be carried out in 5 minutes (see chapter Start (Page 48)).

7.3 Commissioning tools

Commission the electronic weighing system using the following alternatives:

- Operator Panel
- SIWATOOL

The SIWATOOL program allows you to commission the scale without an Operator Panel and without an automation system. In the event of a fault, additional SIWATOOL diagnostics functions enable fast analysis of the cause.

SIWATOOL is included in the WP241 configuration package (see Ordering data (Page 175)). A detailed guide is available for commissioning with SIWATOOL V7. See TIA Portal project "Ready-for-use" for SIWAREX WP231 (<https://support.industry.siemens.com/cs/ww/en/view/66825585>).

7.4 Factory setting of the mode selector

Two DIP switches are located on the left of the Ethernet connector (accessible through the ventilation opening).

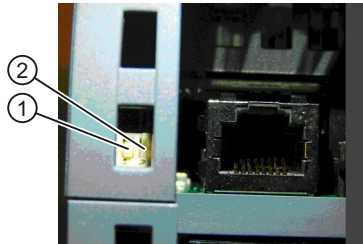

The left-hand switch ① currently has no function. The right-hand switch ② defines the operating environment.

Switch position	Operating environment
Up	Operation integrated in SIMATIC
Down	Stand-alone operation (without SIMATIC controller)

The factory setting is "Operation integrated in SIMATIC".

Note

If the switch is set to the down position while the SIWAREX module is in operation with SIMATIC, the SIWAREX module will not carry out a reset upon loss of power supply to the SIMATIC CPU.

7.5 5 minute quick start with the operator panel and the Ready-for-Use software

7.5.1 Start

The 5 minutes of quick start is performed in this example with a TP700 Comfort Panel connected directly to the electronic weighing system. The Panel communicates directly over MODBUS TCP/IP or via the SIMATIC S7-1200 CPU.

To carry out the quick start, select the "1.0 Setup" function in the main menu and then "1.2 Quick Start". You will be guided through the individual tasks for setting the most important parameters.

The remaining parameters are factory-set in such a way that they can be used in most cases without any changes.

You can download the HMI software used below as free TIA Portal project "Ready-for-use" for SIWAREX WP231 (<https://support.industry.siemens.com/cs/ww/en/view/66825585>).

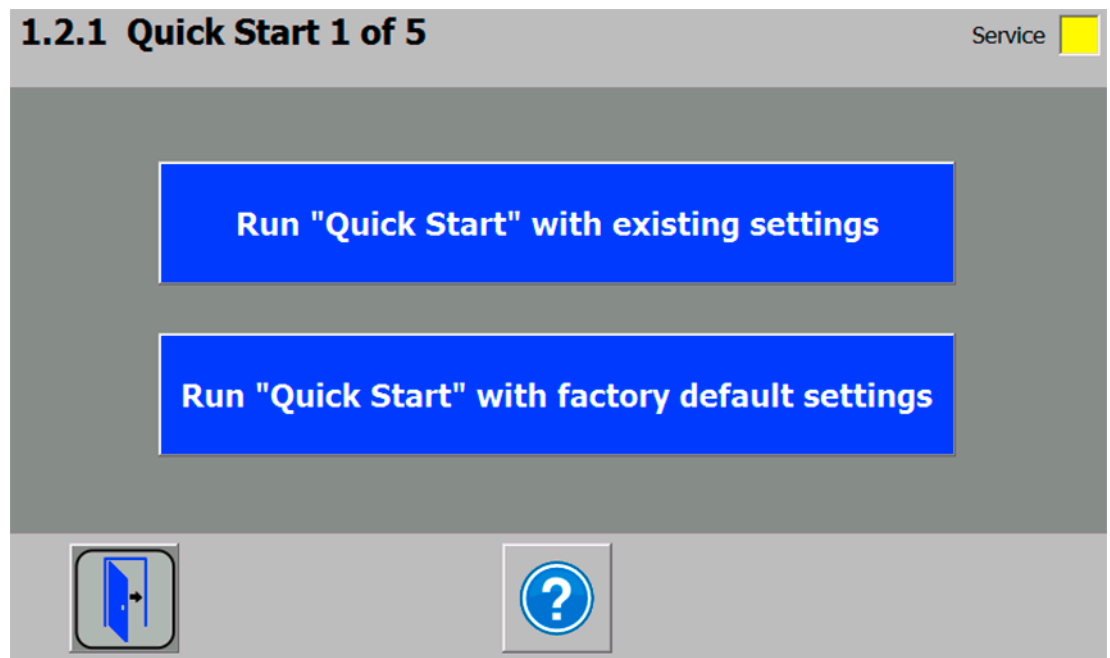

Figure 7-1 Quick start step 1

7.5.2 Standard parameter settings

The quick setup is based on the standard parameter settings. The previously set parameters must therefore be reset prior to the quick setup (except the Ethernet address and Modbus parameters). Service mode must be switched on first. Resetting to the standard parameters can then be carried out.

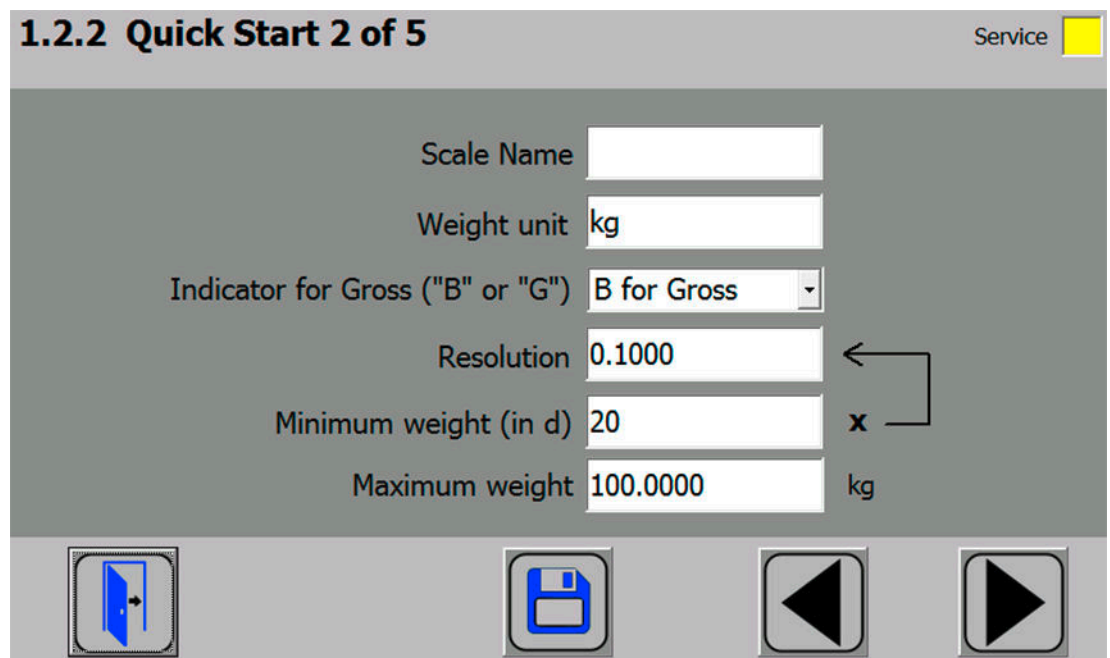

Figure 7-2 Quick start step 2

7.5.3 Selecting the calibration method

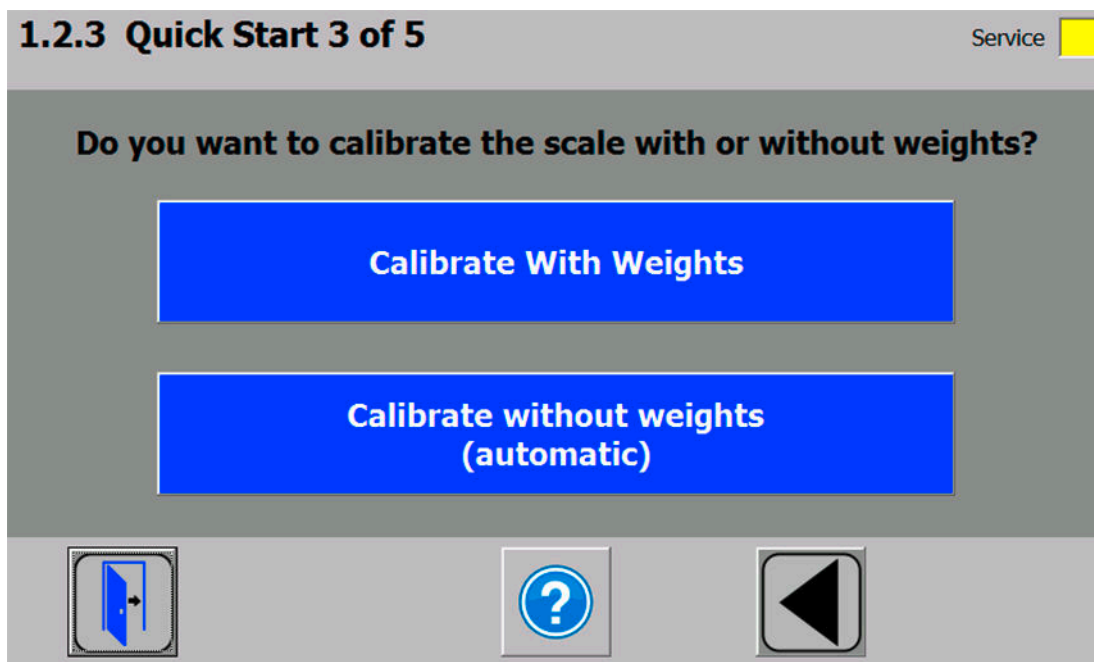

Figure 7-3 Quick start step 3

The module can always be calibrated in two different ways:

- Using reference weights: in the case of a calibration with weights, mechanical influences of the scale construction are also partially taken into account.
- Without weights, using the technical specifications of the connected load cell(s): in the case of automatic calibration, the accuracy of the scale is influenced by the mechanical properties to a greater extent than with calibration using reference weights.

With both methods, make sure that the mechanical properties of the scale are flawless prior to calibration.

7.5.4 Defining the calibration weights

1.2.4 Quick Start - Calibration Weights 4 of 5 Service

Calibration weight 0	0.000	kg
Calibration weight 1	100.000	kg
<i>Calibration weight 2 (optional)</i>	0.000	kg











Figure 7-4 Quick start step 4a

In step 4 you enter the calibration weights which are to be positioned on the scale during the calibration. If the scale is not empty and the current contents are known, you can define an "Calibration weight 0" with the current contents of the scale. With an empty scale, this parameter remains as 0 kg. "Calibration weight 1" usually defines the first reference point of the scale characteristic. A further reference point ("Calibration weight 2") can also be set in addition. This is optional, and may not be necessary depending on the mechanical properties of the scale.

Note that the interval between the calibration weights must be at least 2% of the nominal load of the scale. With a 1 000 kg scale, a calibration weight of at least 20 kg must therefore be used.

7.5.5 Setting calibration points

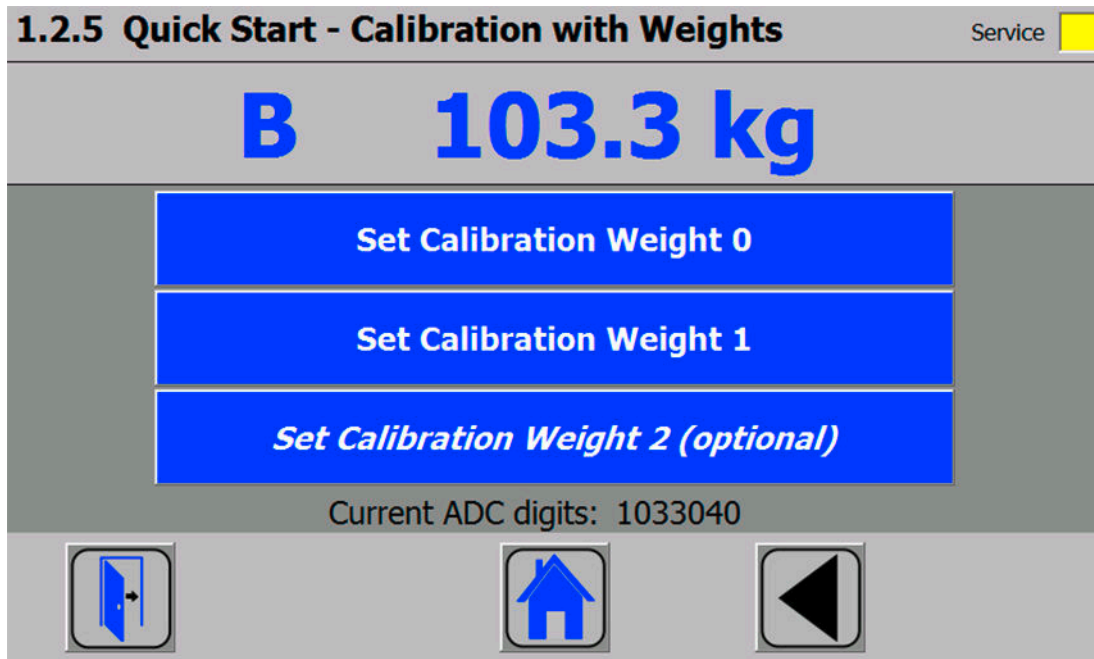

Figure 7-5 Quick start step 5a

Carry out the calibration commands at the end of the quick start:

1. Carry out the "Set calibration weight 0" command. The "Calibration weight 0" defined in step 4 is now visible in the display.
2. Place the "Calibration weight 1" defined in step 4 on the scale construction, and execute the "Set calibration weight 1" command.
3. If an "Calibration weight 2" was selected:
Place "Calibration weight 2" defined in step 4 on the scale construction, and execute the "Set calibration weight 2" command.
4. Calibration of the scale is now complete. Return to the start screen by clicking on the house icon.

7.5.6 Calibrating the scale automatically

The scale can also be calibrated without weights. To do this, it is necessary to enter data specific to the load cells. In addition, it is essential that the scale is empty.

1.2.6 Quick Start 4 of 5 - Load Cells Parameters Service

Number of support points	3
Average of all characteristic values (mV/V)	2.000000
Nominal load of one single load cell	60.0 kg

Figure 7-6 Quick start step 4b

The number of points of support corresponds with a silo, for example, to the number of clamps or feet of the silo. A quadratic platform scale with a load cell at each corner has 4 support points. The characteristic values of the individual load cells are required to calculate the average characteristic value of the cells.

The equation for the calculation is as follows:

$$(\text{characteristic of cell 1} + \text{characteristic of cell 2} + \text{characteristic of cell n}) / n$$

If the exact characteristic values are unknown, it is permissible to also use rounded-off numbers (e.g. 1.0 mV/V, 2.0 mV/V). The nominal load of an individual load cell (not the nominal load of the complete scale!) must subsequently be defined.

7.5.7 Performing the automatic calibration

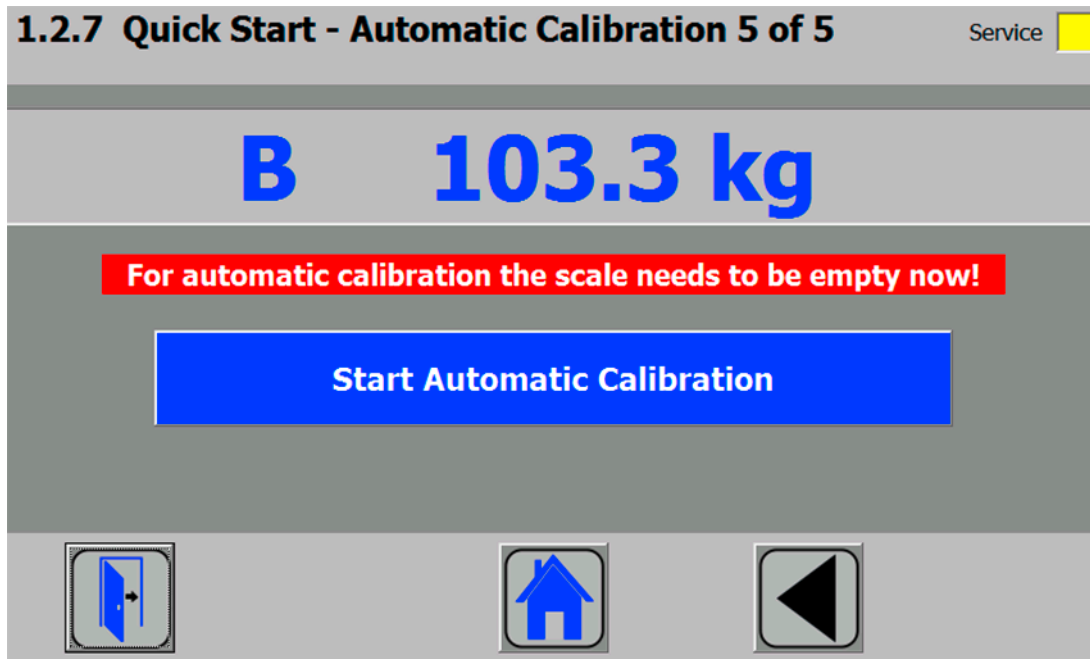

Figure 7-7 Quick start step 5b

Subsequently enter the "Perform automatic calibration" command with the scale empty. The scale is calibrated directly, and clicking on the house icon returns you to the start screen.

7.5.8 Checking the scale following calibration

If the scale is only used for company-internal purposes, a simple check is sufficient.

Perform the following steps:

1. The scale is unloaded and shows "0 kg".
2. Place a known reference weight on the scale.
Check the displayed value.
3. If a second known reference weight is available, place it on the scale in addition.
Check whether the scale displays the sum of the reference weights.
4. Remove the reference weights from the scale.
Check that the display is "0 kg" again.

7.6 5 minute quick setup with SIWATOOL

General information on using the SIWATOOL program can be found in chapter "Service with the SIWATOOL program (Page 57)".

For the quick setup, the required parameters are marked in bold font in data records DR 3 and DR 10. The procedure is described below.

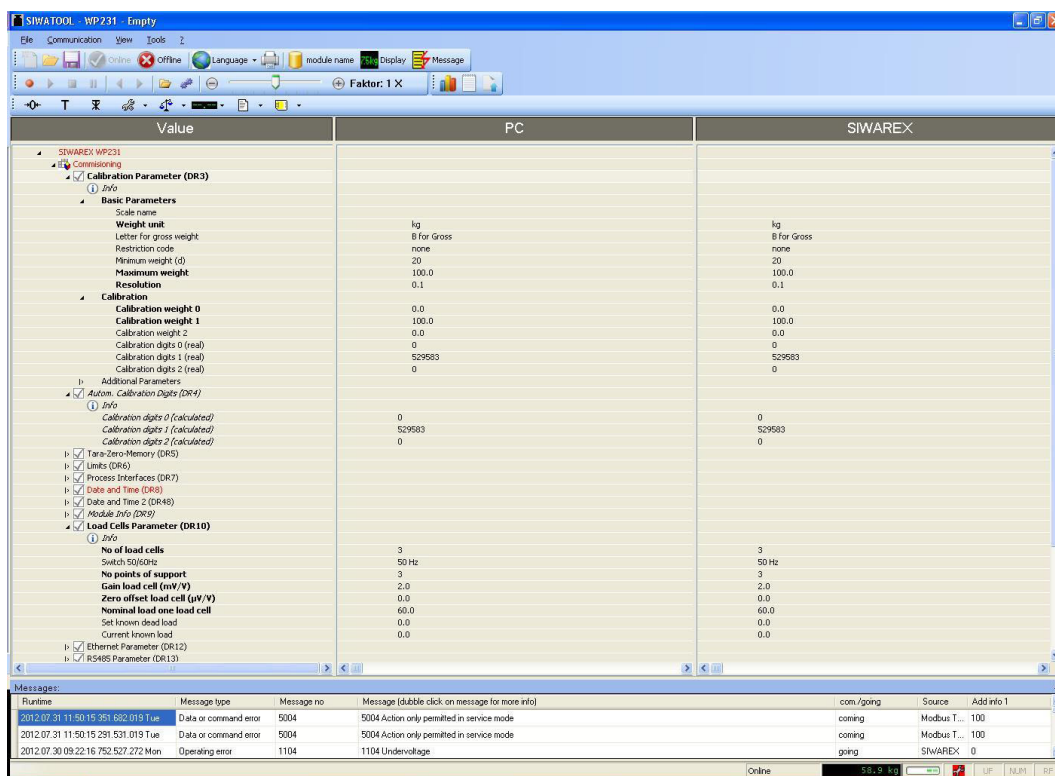

Figure 7-8 Quick setup with marked parameters

7.6.1 Activate service mode

Service mode must be activated in order to change the calibration parameters. You can find the command in the "Service Commands" group (spanner icon).

7.6.2 Load standard parameters

The quick setup is based on the standard settings of the weighing module. Therefore, the standard parameter settings must be reset prior to the quick setup. Firstly, service mode is activated; the standard parameters are subsequently loaded using the "Load standard parameters (12)" command.

7.6.3 Input of required parameters

For commissioning, you must enter the following parameters in data record DR 3 and send these to the module:

- Unit of weight
- Required maximum weighing range of the scale
- Scale interval

Sending/receiving a data record is always carried out by right-clicking on the data record name in the "Value" column in the tree structure.

For example, if data record 3 is to be sent, right-click on "Calibration parameter (DR3)". A submenu is then opened with the option for sending the respective data record to the weighing module or for reading it from the module. All data records can only be sent as complete packets to the SIWAREX or read from it. It is not possible to read or write individual parameters within a data record. Therefore the complete data record must initially be received for every change to parameters within it. The desired parameter can then be edited, and the data record returned. If the data record is not received, the danger exists that different offline parameters will be sent to the scale and overwrite previously active and intentionally defined parameters.

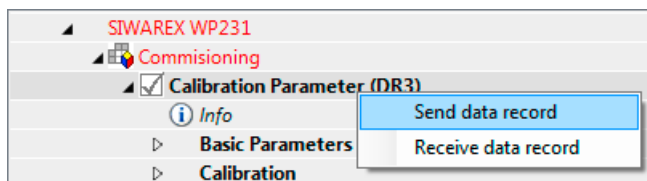

Figure 7-9 Sending/receiving a data record with SIWATOOL V7

You must subsequently enter the required parameters in data record DR 10 and send these to the module.

- Number of support points
- Characteristic value of a load cell in mV/V, or the mean value of the characteristic values if there is more than one load cell
- Rated load of a load cell

7.6.4 Complete automatic calibration

- The scale must be empty (only mechanical dead load).
- Activate the "Automatic Calibration 82" command.
- Activate the "Shift Characteristics 81" command.

7.6.5 Receive all data

Activate the "Receive all data" function in the communication menu.

All parameters can now be saved as a backup file on the hard disk. If a module is replaced, the backup file can be downloaded to the new module within a few seconds. At the time of input of the backup file, the scale is directly in the calibrated state again – without a new calibration.

7.6.6 Checking the scale following calibration

If the scale is only used for company-internal purposes, a simple check is sufficient.

Perform the following steps:

1. The scale is unloaded and shows "0 kg".
2. Place a known reference weight on the scale.
Check the displayed value.
3. If a second known reference weight is available, place it on the scale in addition.
Check whether the scale displays the sum of the reference weights.
4. Remove the reference weights from the scale.
Check that the display is "0 kg" again.

7.7 Service with the SIWATOOL program

You can use the SIWATOOL program to commission the scale independently of the SIMATIC automation system.

The program is included in the configuration package.

Install the SIWATOOL program (SIWATOOL catalog) on your PC for commissioning.

7.7.1 Windows and functions of SIWATOOL

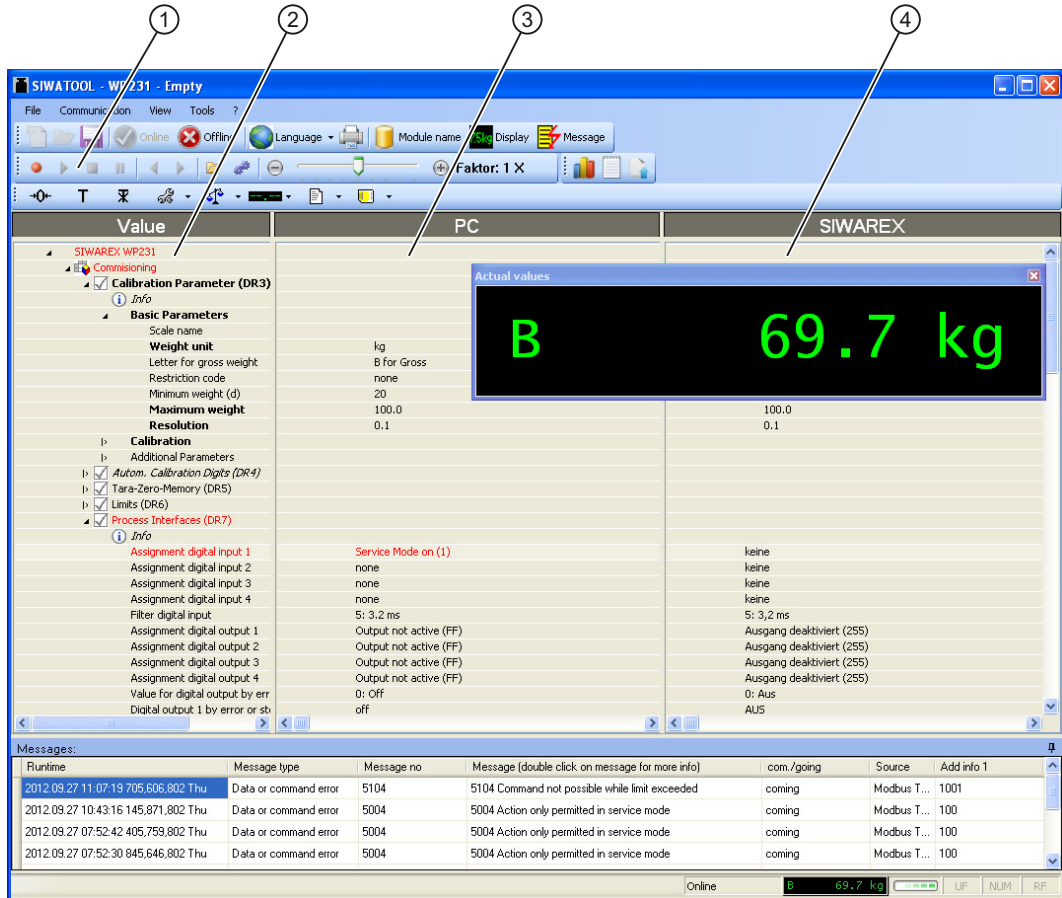

- ① Control elements for SIWATOOL and operation of the scale
- ② Parameter list of the SIWATOOL module
- ③ Offline values of the SIWAREX module
- ④ Online values of the connected SIWAREX module

Figure 7-10 Layout of the SIWATOOL user interface

Sending/receiving a data record is always carried out by right-clicking on the data record name in the "Value" column in the tree structure.

For example, if data record 3 is to be sent, right-click on "Calibration parameter (DR3)". A submenu is then opened with the option for sending the respective data record to the weighing module or for reading it from the module. All data records can only be sent to or read from the SIWAREX as complete packets. It is not possible to read or write individual parameters within a data record. Therefore the complete data record must initially be received for every change to parameters within it. The desired parameter can then be edited, and the data record returned. If the data record is not received, the danger exists that different offline parameters will be sent to the scale and overwrite previously active and intentionally defined parameters.

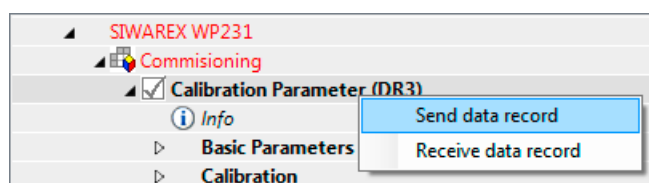

Figure 7-11 Sending/receiving a data record with SIWATOOL V7

7.7.2 Offline parameter assignment

All scale parameters can be edited and saved without an electronic weighing system.

This reduces the setup time. You can thus prepare the parameters for several scales in your office, and subsequently transfer them to the electronic weighing system during setup.

Data from one scale currently in operation can be exported and used to set up another scale.

7.7.3 IP address for SIWAREX

The factory-set IP address is 192.168.0.21. This address is also preset in SIWATOOL. The connection to a SIWAREX module can be established immediately. The network card used must be configured for this network.

If the connection is to be established to a specific SIWAREX module, its IP address must be set in SIWATOOL. The setting is carried out with the menu item "Communication/Set Ethernet Configuration...".

If the IP address of a SIWAREX module is unknown, it can be determined using the additional program "Primary Setup Tool". The program is included in the SIWAREX configuration package.

During the setup, a new IP address can be assigned to the module using SIWATOOL.

The assignment of a new IP address to a SIWAREX module is necessary if several SIWAREX modules are present in one network.

The following ports are used by SIWAREX:

- SIWATOOL port: 23006
- MODBUS TCP/IP port: 502
- TFTP for firmware download port: 69

7.7.3.1 Entering a known SIWAREX IP address

To establish a connection to a SIWAREX module, enter the IP address in SIWATOOL. Under the menu item "Communication", select "Set Ethernet Configuration...". Enter the IP address of the SIWAREX module in the following window. To activate the IP address and establish a connection to the SIWAREX module, subsequently click on "Online".

7.7.3.2 Determining an unknown IP address

If the IP address of a connected SIWAREX module is unknown, it can be determined using the program "Primary Setup Tool". The program is included in the configuration package (Page 175).

Install the program "Primary Setup Tool". When started, the program can determine the Siemens devices present in the network.

The MAC (Media Access Control) address can be read on the front of the SIWAREX module. Every device has an MAC address which is unique worldwide.

The IP address can be determined from the identified MAC address. The Primary Setup Tool also allows the IP address of a SIWAREX module to be set/changed.

Additional information on the Primary Setup Tool can be found in the associated manual.

7.7.3.3 Setting up a network

Several SIWAREX modules can be connected together in a network via a switch. Via the network, you can use SIWATOOL to assign parameters to and start the various modules or connect a common Operator Panel.

7.7.4 Online parameter assignment

To switch to online mode, connect the PC to the SIWAREX module using an Ethernet cable. Set the IP address of the SIWAREX module in the communication menu.

You can change all parameters in the SIWAREX module in online mode. The message window shows the current contents of the message buffer of the SIWAREX module. The current process values are displayed in the "Online" column.

For test purposes, you can send various commands to the SIWAREX module. Differences between the online/offline data are marked in red by SIWATOOL. This affects both the associated data record and the individual parameter.

In order to archive data, all data can be exported from the SIWAREX module and saved as a file or printed.

Note

You can edit all data in the SIWAREX module in online mode. The changes are not automatically imported to the corresponding scale data block.

To download the data to the SIWAREX module, select the data record with a right mouse click and send it explicitly to the SIWAREX module.

Online parameter trends can be recorded and played back using the recorder function located at the top right-hand edge of SIWATOOL. You can use the "Configure recorder" button to select the data records to be recorded and to set the save parameters. The playback speed can be set using a slider.

7.7.5 Available help options

SIWATOOL offers various help options for operation:

- Info card
You can select the "Info" item directly underneath the individual data records in the navigation tree. This info card explains how the data record influences the scale behavior.
- Tooltip
If you move the mouse over a button or parameter, a corresponding help text is displayed.
- Help
Click on the menu option "Help" to call up the SIWATOOL help. The Help can be opened separately.

7.7.6 Entering parameters with SIWATOOL

There is a defined procedure for handling parameters. The current parameters in the SIWAREX module are displayed in the right-hand window, while the parameter values on the PC are displayed in the left-hand window. The new parameter value is entered first in the left-hand window. If several parameters of the data record are to be changed, they are entered consecutively. The data record is subsequently selected in the tree view and sent to the SIWAREX modules using the right mouse button.

Parameters are always changed as complete data records, rather than individually.

7.7.7 Recording scale traces

Scale traces can be recorded and exported using SIWATOOL. The recording is started and stopped using commands, and recorded traces can also be deleted. The trace recording cycle is set in data record DR7. A dialog window is called with the "Export trace data" button. The trace is displayed in this window as a table or graphic, and the data can be exported to csv or Excel and then processed further. The commands for starting and stopping are present in the "Trace commands" group (yellow memory card icon) in SIWATOOL.

All important measured values, messages and changes in status are recorded.

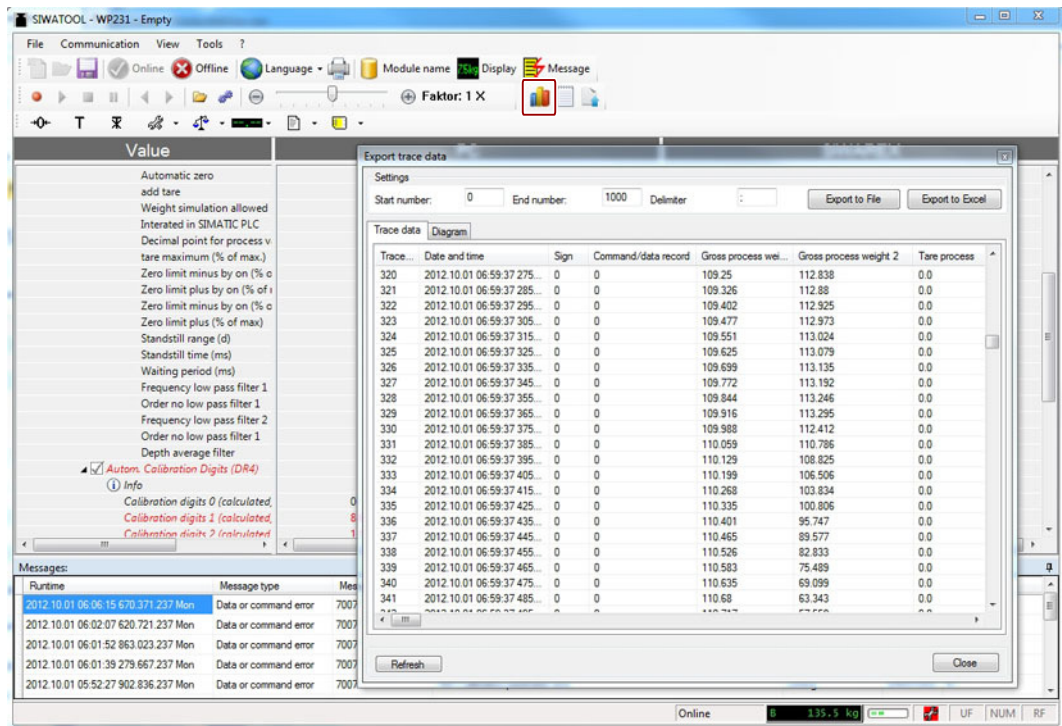

Figure 7-12 Trace export

7.7.8 Reading out the saved scale logs

The scale logs are saved powerfail-proof in the internal memory of the SIWAREX.

You can read out the logs with SIWATOOL using the "Logs" button .

A new window is opened, and all logs present in the weighing module are read out using "Refresh". You can subsequently save these in EXCEL or .csv format.

7.7.9 Firmware update

New firmware versions can be transferred to the SIWAREX module using SIWATOOL. In order to transfer the firmware, the Windows firewall must be configured in such a way that SIWATOOL is registered as an approved program. The TFTP protocol is used for the transfer. Firewalls or other protection software may interfere with or prevent the transfer of data per TFTP protocol. In such cases, the respective protective mechanism must be temporarily deactivated for the duration of the update, or an alternative PC used.

The latest firmware version can be found under Industry Online Support (<http://support.automation.siemens.com/WW/view/en/10807015/133100>).

Note

Following transfer of the new firmware, the parameters of the SIWAREX module are assigned default values

You should therefore export and save the original parameter values prior to the firmware update. Following the firmware update, the saved data can be converted by SIWATOOL to the new firmware version.

Saving existing parameters

- Export the current parameters
Select the "Receive all data records" function from the menu under "Communication". The current parameter set is then transferred to SIWATOOL.
- Save the current data record in a file.

Transferring the new firmware version to the SIWAREX module

Note

During the firmware transfer, the SIWAREX module works to a limited extent with the old firmware version, and the new firmware is flashed in the background. For this reason, you must not switch off the module during the firmware transfer.

1. Set the SIMATIC CPU to "STOP".
2. Register with SIWATOOL on the SIWAREX module.
3. Call the firmware download using the function key .
4. Select the current firmware file under "Firmware Download".
5. Click the "Start transfer" button.

Following the transfer, the SIWAREX module must be switched off and then on again. This activates the new firmware.

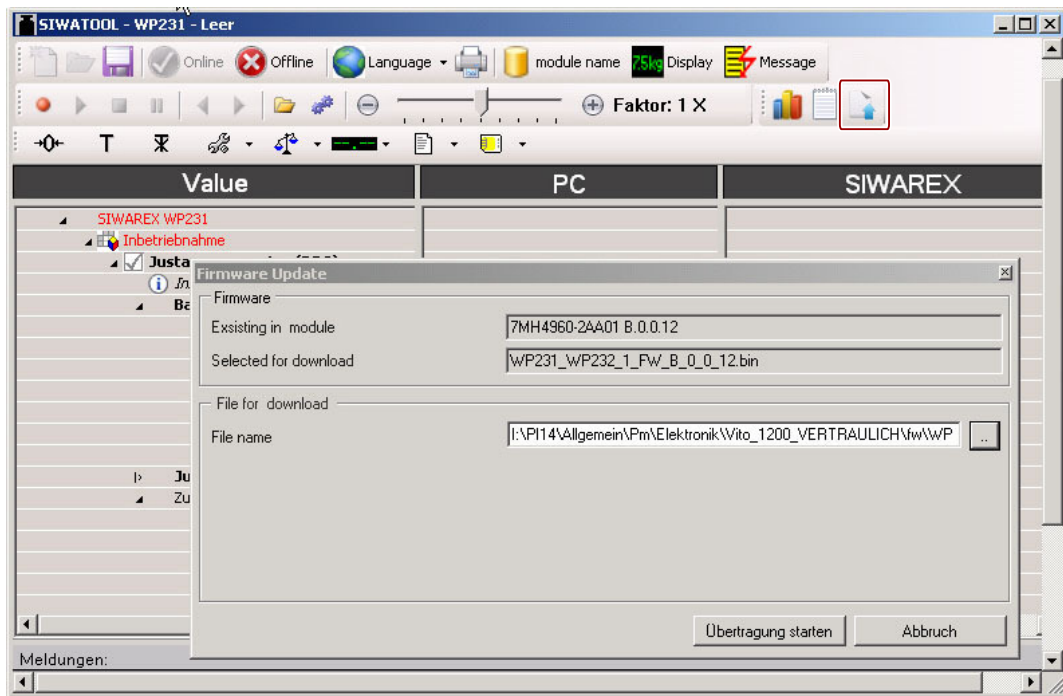

Figure 7-13 Downloading the firmware with SIWATOOL

Scale parameters and functions

8.1 Parameters and functions

The weighing module employed here can be used as a non-automatic weighing instrument pursuant to OIML R76.

All parameters are set to default values in the factory. You can restore the configuration to factory settings using the "Load factory settings" command.

You can also create your own restore point. You can reload the saved configuration at a later point in time with the "Load restore point" command.

The default parameters are set such that the scale is immediately ready for operation. The weight value indicates changes in weight on the load cell, but only corresponds to the actual weight following a calibration. You do not need to re-enter all parameters. The advantage of this solution is that you can decide the default values to be retain and the parameters that need to be adapted for your application.

All parameters are divided into data records (DR). The data records are organized in steps (tasks) to be implemented during commissioning or during the process. Information on limitations in data record communication with SIMATIC CPUs can be found in chapter → Information about previous versions (Page 17).

The scale functions governed by the parameters are also described in the parameter description below.

First, the parameters of a given data record are displayed in a table. The detailed parameter description for the parameters of this data record then follows.

When it receives new parameters, the SIWAREX module runs a validation check. In the event of a parameter assignment error, the data record is not applied (not saved) by the SIWAREX module and a data/operator error is reported.

8.2 Assigning parameters to the electronic weighing system with SIWAREX DB

Introduction

You can assign parameters to the SIWAREX WP electronic weighing systems using the SIMATIC HMI, the SIWATOOL or the SIMATIC S7 control system. The procedure described for you is oriented to the data records (DS) from SIWATOOL and the SIMATIC S7 control system.

Procedure

1. Set the Load cell type parameter to SIWAREX DB in data record DR03. (Not relevant for SIWAREX WP321)
2. Set the RS 485 protocol parameter to SIWAREX DB and the RS 485 baud rate to 115 200 bits/s in data record DR13.
3. Activate the load cell input for every connected load cell in the data record DR70.
4. Specify whether 4- or 6-wire load cells are connected for the Sensor type parameter in data record DR70.
5. In order to identify the load cell type and the installation location of your load cells enter the Load cell manufacturer, Load cell order number and Location Designation of Sensor in the data record DR70.
6. The details of the data data records and parameters are specified in the parameter assignment tables.

See also

Scale parameters and functions (Page 65)

8.3 DR 2 command code

DR 2 is a special data record used to transfer commands to the SIWAREX module by SIWATOOL.

8.4 DR 3 calibration parameters

The calibration parameters need to be checked and if necessary modified for all scales.

The scale is basically defined by calibration parameters and calibration operation. A wire jumper on the P-PR (Parameter Protection) terminals means that the DR 3 data can no longer be changed (write-protected). All changes in data record 3 require service mode to be switched on for the module. If service mode is not active, all parameter inputs are directly rejected with an error.

Procedure

- Check all parameters and modify them as required
- Transfer the DR 3 data record from SIWATOOL to the scales
- Calibrate the scale
- Transfer the DR 3 data record from the scales to SIWATOOL

Table 8-1 Assignment of data record 3

Variable	Note	Type	Length (bytes)	Read/write protection	Default	Min.	Max.	Modbus registers
Data record number	Contains no. of data record	USHORT	2	r	3	-	-	1000
Length	Data record length information	USHORT	2	r	192	-	-	1001
Application	Information on which application the DR belongs to	USHORT	2	r	101	-	-	1002
Version identifier	Information on the current data record version	USHORT	2	r	1	1	65635	1003
Scale name header	Maximum length and actual length of string for scale name	UBYTE[2]	2	rwP	12,12	-	-	1004
Scale name (Page 71)	Scale name specified by user	CHAR[12]	12	rwP	" "	-	-	1005
Weight unit header	Maximum length and actual length of string for unit of weight (e.g.: g, kg, t, ...)	UBYTE[2]	2	rwP	04,04	-	-	1011
Unit of weight (Page 71)	Weight unit	CHAR[4]	4	rwP	"kg••"	-	-	1012
Gross identifier header	Maximum length and actual length of string for weight unit	UBYTE[2]	2	rwP	02,02	-	-	1014
Gross identifier (Page 71)	Abbreviation of gross (B or G), only one byte is used!	CHAR[2]	2	rwP	"B"	"B"	"G"	1015
Load cell type	Type of connected load cell: 0: Analog DMS load cell(s) 1: Digital load cell Mettler-Toledo type WMS/WMH 2: Digital load cell Mettler-Toledo type PBK9-APW/PFK9-APW 3: Digital load cell Wipotec 4: SIWAREX DB	USHORT	2	rw	0	-	-	1016
Code for regulations (Page 72)	0: None 1: OIML R76 (available soon)	USHORT	2	rwP	0	-	-	1017
Minimum weighing range (Page 72)	Minimum number d	USHORT	2	rwP	20	0	65535	1018
Reserve	Reserve	USHORT	2	rw	0	-	-	1019
Maximum weighing range (Page 72) ¹⁾	Maximum weight	FLOAT	4	rwP	100	> weighing_range_min	maximum number range	1020

Variable	Note	Type	Length (bytes)	Read/ write protection	Default	Min.	Max.	Modbus registers
Calibration weights 0, 1, 2 and calibration digits 0, 1, 2 (Page 73)	Calibration weight 0 ¹⁾ (usually the zero point)	FLOAT	4	rwP	0	1	maximum number range	1022
	Calibration weight 1 ¹⁾	FLOAT	4	rwP	100	1	maximum number range	1024
	Calibration weight 2	FLOAT	4	rwP	0	1	maximum number range	1026
	Calibration digits 0 determined during calibration with calibration weight 0	FLOAT	4	rwP	0	-1000000	1000000	1028
	Calibration digits 1 determined during calibration with calibration weight 1	FLOAT	4	rwP	2000	0	1000000	1030
	Calibration digits 2 determined during calibration with calibration weight 2	FLOAT	4	rwP	0	0	1000000	1032
Scale interval (Page 73) ¹⁾	Resolution weighing range 1 (1*10**k, 2*10**k, 5*10**k]; k: -3 ... 2)	FLOAT	4	rwP	0.1	0.001	50	1034
Zero by power-on (Page 73)	Zero by on 0: Zero by on off 1: Zero by power-on on	BIT	0	rw	0	0	1	1036.16
Zero by power-on when tare ≠ 0 (Page 73)	Zero by on when tare ≠ 0 0: No zero by on performed when tare weight ≠ 0 1: Zero by power-on when tare ≠ 0	BIT	0	rw	0	0	1	1036.15
Automatic zero adjustment (Page 73)	0: auto. zero adjustment off 1: Autom. zero adjustment on	BIT	0	rw	0	0	1	1036.14
Subtractive / additive tare device (Page 74)	Subtractive / additive tare device 0: Subtractive tare device 1: Additive tare device	BIT	0	rwP	0	0	1	1036.13
Weight simulation (Page 74)	Weight simulation 0: Weight simulation inactive 1: Weight simulation value of DR16 applied Weight simulation is always disabled when write protection is enabled	BIT	0	rwP	0	0	1	1036.12
Bit 5	Bit 5: Reserve	BIT	0	rw	0	0	1	1036.11

Variable	Note	Type	Length (bytes)	Read/ write protection	Default	Min.	Max.	Modbus registers
Bit 6	Bit 6: Reserve	BIT	0	rw	0	0	1	1036.10
Bit 7	Bit 7: Reserve	BIT	0	rw	0	0	1	1036.9
Bit 8	Bit 8: Reserve	BIT	0	rw	0	0	1	1036.8
Bit 9	Bit 9: Reserve	BIT	0	rw	0	0	1	1036.7
Bit 10	Bit 10: Reserve	BIT	0	rw	0	0	1	1036.6
Bit 11	Bit 11: Reserve	BIT	0	rw	0	0	1	1036.5
Bit 12	Bit 12: Reserve	BIT	0	rw	0	0	1	1036.4
Bit 13	Bit 13: Reserve	BIT	0	rw	0	0	1	1036.3
Bit 14	Bit 14: Reserve	BIT	0	rw	0	0	1	1036.2
Bit 15	Bit 15: Reserve	BIT	2	rw	0	0	1	1036.1
Decimal places for process values (Page 74)	0: No rounding 1: Rounding to 1 decimal place 2: Rounding to 2 decimal places 3: Rounding to 3 decimal places 4: Rounding to 4 decimal places 5: Rounding to 5 decimal places 6: Rounding to 6 decimal places	USHORT	2	rwP	0	0	6	1037
Maximum tare load (Page 74)	Range of the subtractive tare device [in % of max. weighing range] (must not exceed 100% with regulation code "OIML")	FLOAT	4	rwP	0	0	250	1038
Maximum negative zero setting limit (power-on) (Page 75)	Negative range of the zero by on device [in % of maximum weight WBmax] (amount of positive + negative zero setting limit must not exceed 20% with country code "OIML")	FLOAT	4	rwP	1.0	0	100.0	1040
Maximum positive zero setting limit (power-on) (Page 75)	Positive range of the zero by on device [in % of maximum weight WBmax] (amount of positive + negative zero setting limit must not exceed 20% with country code "OIML")	FLOAT	4	rwP	3.0	0	100.0	1042
Maximum negative zero setting limit (semi-automatically) (Page 75)	Negative range of the semi-automatic zeroing [in % of maximum weight WRmax] (amount of positive + negative zero setting limit must not exceed 4% with country code "OIML")	FLOAT	4	rwP	10.0	0	100.0	1044
Maximum positive zero setting limit (semi-automatically) (Page 75)	Positive range of the semi-automatic zeroing [in % of maximum weight WRmax] (amount of positive + negative zero setting limit must not exceed 4% with country code "OIML")	FLOAT	4	rwP	3.0	0	100.0	1046

8.4 DR 3 calibration parameters

Variable	Note	Type	Length (bytes)	Read/ write protection	Default	Min.	Max.	Modbus registers
Standstill range (Page 75)	Standstill range (in d)	FLOAT	4	rwP	0.1	0	maximum number range+	1048
Standstill time (Page 76)	Standstill time 1 in ms	TIME	4	rwP	2000	10	10000	1050
Standstill waiting time (Page 76)	Waiting time until standstill. 0: standstill-dependent scale command, if there is no standstill, immediately rejected. > 0: Maximum waiting time until command is executed	TIME	4	rw	2000	0	10000	1052
Low-pass cut-off frequency (Page 77)	Frequency low pass filter 1: 0: Filter disabled	FLOAT	4	rwP	0.5	tbd	tbd	1054
Low-pass filter number (Page 77)	Ordinal number of low-pass filter 1: Filter ordinal number 2*(1 ... 5)	USHORT	2	rwP	4	2	10	1056
Reserve 2	Reserve	USHORT	2	rw	0	-	-	1057
Low-pass filter limit frequency (commissioning) (Page 77)	Frequency low pass filter 2: 0: Filter disabled	FLOAT	4	rw	0	tbd	tbd	1058
Low-pass filter number (commissioning) (Page 78)	Ordinal number of low-pass filter 2: Filter ordinal number 2*(1 ... 5)	USHORT	2	rw	4	2	10	1060
Mean value filter depth (Page 78)	Filter for digit values, Permissible filter depth: 0 ... 250	USHORT	2	rwP	10	0	250	1061
Display weighing range data (Page 78)	Display weighing range data 0: No 1: Yes	USHORT	2	rwP	0	0	1	1062
Interface for legal trade display (Page 78)	Selection of interface for SecureDisplay: 0: SecureDisplay not used 1: SecureDisplay over SIWAREX Ethernet port 2: SecureDisplay on CPU 1200	USHORT	2	rw	0	0	3	1063
Firmware version SecureDisplayHeader	Maximum length and actual length of string for FW version of SecureDisplay	UBYTE[2]	2	rw	12, 12			1064

Variable	Note	Type	Length (bytes)	Read/ write protection	Default	Min.	Max.	Modbus registers
Firmware version SecureDisplay (Page 78)	FW version of the SecureDisplay used on the HMI	CHAR[12]	12	rw				1065
Reserve	Reserve	UBYTE[2]	2	rw	0	-	-	1071
Reserve	Reserve	CHAR[20]	20	rw	0	-	-	1072
Reserve	Reserve	UBYTE[2]	2	rw	0	-	-	1082
Reserve	Reserve	CHAR[20]	20	rw	0	-	-	1083
Minimum display size [%] (Page 78)	Maximum factor for minimizing the SecureDisplay. Value must not be smaller than the smallest value defined in the DisplayCali file.	USHORT	2	rwP	0	-	-	1093
Reserve 4	Reserve	FLOAT	4	rw	0	-	-	1094

¹⁾ Parameter for calculation of calibration points with theoretical calibration

8.4.1 Scale name

You can select any name, but it may not exceed 12 characters. You can enter any designation.

Note

The scale name cannot be changed after official verification.

8.4.2 Unit of weight

A string with up to four digits can be specified as the unit of weight, e.g.: t, kg, lbs. The defined unit of weight applies to all weight specifications. Entries are not be converted if the unit of weight has changed. Entries must be left-aligned.

8.4.3 Gross identifier

The gross identifier specifies the letter, B (for brutto) or G (for gross), to be used in the display for gross weights.

8.4.4 Load cell type

Sets the connected load cell type.

Communication with the digital load cells is started with command 905 and stopped with command 906. The receipt of the cyclic weight telegrams from the digital load cell is monitored. If no telegram is received for the configured time, for example, 2000 ms, the electronic weighing system reports an operation fault "Digital load cell is not ready". A status bit in the DR 30 also provides information about whether the digital load cell is ready. If the status bit is not set, the weight values cannot be evaluated because no plausible weight values are received. In addition to selecting the digital load cell, the standstill time and standstill range is configured as follows in DR 3:

- Stability time = 0 or stability weight = 0 status information of the Mettler load cells for standstill display
- Stability time = 0 or stability weight = 0 Electronic weighting system calculates the stability as with connected analog load cell from the stability parameters

8.4.5 Code for regulations

Activates a parameter check in accordance with OIML for operation requiring verification of the scales.

Selection code	
0 (default)	No regulations
1	OIML regulations

8.4.6 Minimum weighing range

The weight value can only be used above the minimum weighing range for legal trade registration with the specified scale interval. The minimum weighing range in the unit "d" (scale interval) is defined during calibration/official verification.

The factory setting is 0 d. 20 d is generally entered for legal trade scales.

8.4.7 Maximum weighing range

For purposes requiring official calibration, the weight can only be used with the defined scale interval below the maximum weight (+ 9 d, d = scale interval). The maximum weight is defined during commissioning.

The maximum weight depends on the number and type of load cells used.

8.4.8 Calibration weights 0, 1, 2 and calibration digits 0, 1, 2

The calibration weights and corresponding calibration digits define the characteristic curve of the scales. A detailed description can be found in section Calibration procedure (Page 79).

8.4.9 Scale interval

The scale interval for the weighing range can be defined in accordance with EN 45501 (0.0001 to 50).

8.4.10 Zero by power-on

The scales can automatically be set to zero when the supply voltage is switched on (in legal trade operation, this is at the end of the startup waiting time). A weight of $\pm 10\%$ of the maximum measuring range can be set to zero by power-on for legal trade scales.

NOTICE
If the scales are not being used in legal trade operation (no OIML restrictions), fully loaded scales can also be set to zero once this function is enabled. The function can, however, be limited by setting a maximum and minimum weight for zero by power-on. See the section on maximum and minimum weights for zero by power-on.

8.4.11 Zero by power-on when tare $\neq 0$

The scales can automatically be set to zero when the supply voltage is switched on. If the Zero by power-on (Page 73) function is enabled, this still does not specify whether zero by power-on is also to be performed if the tare weight in the tare memory is not equal to zero.

If the "Zero by power-on activated for tared scales" parameter is set, the tare weight is also be cleared upon zero by power-on; if the parameter is not set, the scales are not set to zero.

8.4.12 Automatic zero adjustment

If necessary, the scales can be set semi-automatically to zero by the user by means of the "Zeroing" command.

The automatic adjustment sets the scale to zero without a further command in the event of slow zero drifting. Slow drift is assumed if the OIML R76 criteria for this are met.

Note

If the scales are not being used in legal trade operation (no OIML restrictions) and this function is enabled, the scales may eventually read zero after a slow drift even if they are fully loaded. The function can, however, be limited by setting a maximum and minimum weight for zeroing.

8.4.13 Subtractive / additive tare device

If necessary, the scales can be tared using the Tare" command.

The display value is hidden when a subtractive tare is enabled if the gross value exceeds the maximum weighing range by more than 9e.

When an additive tare is enabled, the display value is not hidden until the net weight exceeds the maximum weighing range. The maximum subtractive tare is 100 % and the maximum additive tare 250 % of the maximum weighing range.

The current tare value is deleted if you switch between additive and subtractive taring.

NOTICE

There is no automatic evaluation of whether there is sufficient load cell measuring range capacity for an additive tare.
--

8.4.14 Weight simulation

For test purposes, weight simulation can be enabled instead of actual weighing. The simulated weight is specified using the DR 16 data record. Weight simulation can, in certain situations, facilitate scale testing and commissioning. The simulated weight is indicated on the main display with the word "TEST".

8.4.15 Decimal places for process values

This parameter is used to specify the number of decimal places to which the process values are to be rounded. This specification separates the main weight display, which is subject to the legal trade restrictions, and the values used in the control software.

8.4.16 Maximum tare load

The weighing module accepts any external tare specification which is less than the maximum tare load (percentage of maximum weighing range). Tare commands are also accepted provided that the current gross weight is less than the configured maximum tare load.

8.4.17 **Maximum negative zero setting limit (power-on)**

Zeroing means the scales are automatically set to zero when the supply voltage is switched on.

If zero by power-on upon supply voltage ON is enabled, you can limit the effect of this function. The limitation is based not on the actual weight, but rather on the weight which the scales would display had there been no zeroing.

8.4.18 **Maximum positive zero setting limit (power-on)**

Zeroing means the scales are automatically set to zero when the supply voltage is switched on.

If zero by power-on upon supply voltage ON is enabled, you can limit the effect of this function. The limitation is based not on the actual weight, but rather on the weight which the scales would display had there been no zeroing.

8.4.19 **Maximum negative zero setting limit (semi-automatically)**

Zeroing defines the current weight of the scales as zero.

You can restrict the effect of the zeroing function by defining limits. The limitation is based not on the current gross weight, but rather on the weight which the scales would display had there been no zeroing (time of scale calibration).

For legal trade scales, the limitation is 4 % of the weighing range between the negative and positive weight for zeroing.

8.4.20 **Maximum positive zero setting limit (semi-automatically)**

You can restrict the effect of the zeroing function by defining limits. The limitation is based not on the current weight, but rather on the weight which the scales would display had there been no zeroing (time of scale calibration).

For legal trade scales, the limitation is a maximum of 4 % of the weighing range between the negative and positive weight for zeroing.

8.4.21 **Standstill range**

Standstill monitoring checks whether the scales are correctly balanced. Scale standstill is registered if the weight changes by less than a specified fluctuation in d (standstill value) over a specified time (standstill time). Standstill monitoring is used in static scale mode (commands: zeroing, taring). The diagram below illustrates how standstill monitoring works.

The current weight can only be registered in legal trade applications if standstill is reached.

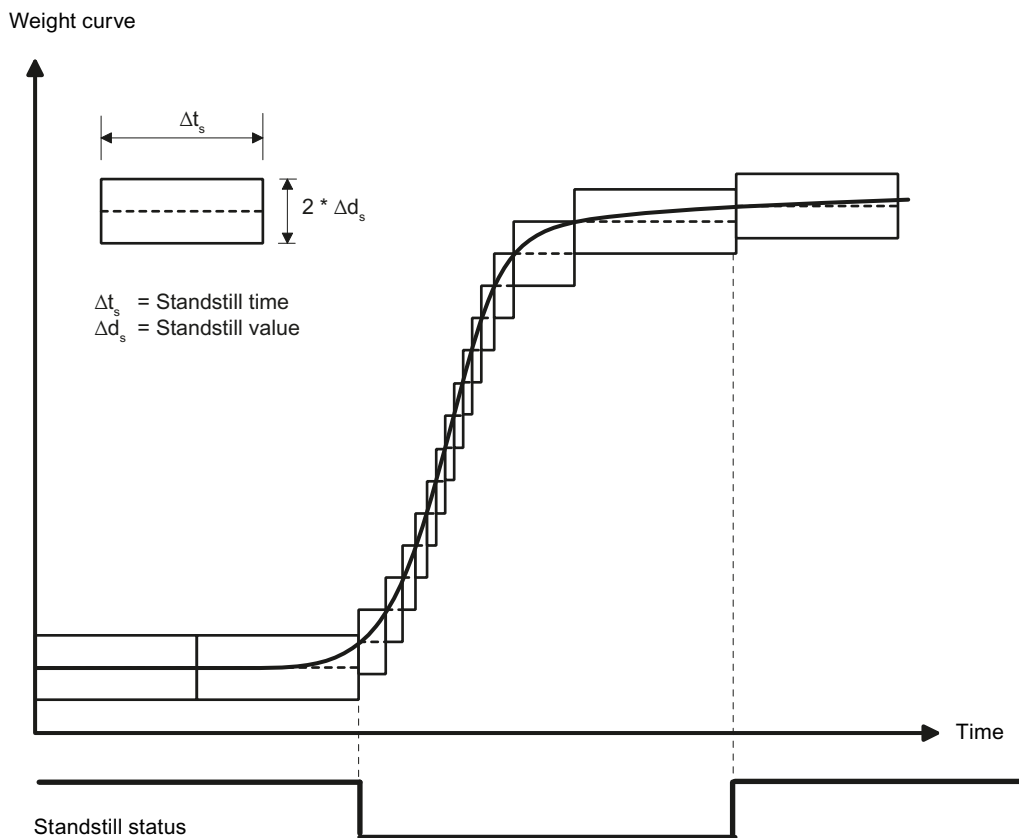

Figure 8-1 Standstill monitoring

8.4.22 Standstill time

Standstill monitoring checks whether the scales are correctly balanced. Scale standstill is registered if the weight changes by less than a specified fluctuation in d (standstill value) over a specified time (standstill time). Standstill monitoring is used in static scale mode (with the following commands: zeroing, taring).

The current weight can only be registered in legal trade applications if standstill is reached.

8.4.23 Standstill waiting time

Standstill waiting time is a maximum waiting time for standstill upon the execution of a command which depends on standstill (taring, zeroing, registering). A technology message is generated if the command cannot be executed during the standstill waiting time because there is no standstill.

If the standstill waiting time is equal to zero, a command requiring standstill is rejected immediately if there is no standstill.

8.4.24 Low-pass cut-off frequency

There is a critically damped low-pass filter for suppressing faults. The diagram below shows the step response of the filter ($f = 2$ Hz). The entry "0" means that the filter is switched off. A cut-off frequency between 0.05 and 20.0 Hz can be specified.

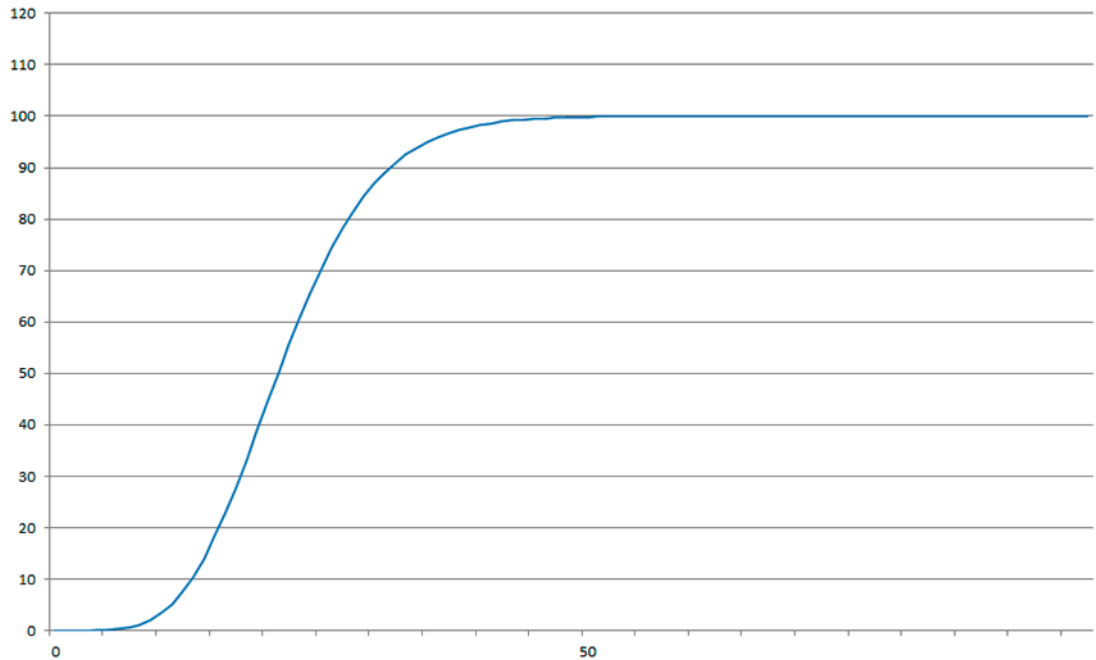

Figure 8-2 Step-forced response of the digital low-pass filter when $f = 2$ Hz

The definition of the cut-off frequency is extremely important for the suppression of faults. Defining the cut-off frequency defines the "speed" of the scale's response to changes in the measured value.

A value of 5 Hz, for example, results in a relatively rapid response to a change in weight; a value of 0.5 Hz makes the scales "slower".

8.4.25 Low-pass filter number

The number of the filter defines the effect of damping. The values 2, 4, 6, 8, and 10 can be set. The higher the selected filter number, the higher the effect.

8.4.26 Low-pass filter limit frequency (commissioning)

The second low-pass filter can be used for test purposes. Its function is identical to that of the (operating) low-pass filter. An analysis of the signal curve after this low-pass filter can provide additional information on the environment of the scales.

8.4.27 Low-pass filter number (commissioning)

The second low-pass filter can be used for test purposes. Its function is identical to that of the (operating) low-pass filter. An analysis of the signal curve after this low-pass filter can provide additional information on the environment of the scales.

8.4.28 Mean value filter depth

The mean value filter is used to steady the weight against random interference. The weight is the mean value of n ($n = \text{max. } 250$) weights which are recorded by the weighing module every 10 ms, e.g. when $n = 10$, the mean of 10 weights is calculated. Every 10 ms, the oldest value is discarded and the newest value included in the calculation.

8.4.29 Display weighing range data

The weighing range data is relevant to operation with verification capability. The "Display weighing range data" parameter is used to define whether the weighing range data is to be output permanently in the "SecureDisplay" on the HMI. Alternatively, it can be displayed separately using the command "802".

8.4.30 Interface for legal trade display

This parameter is used to define whether the legal trade display "SecureDisplay" is to be made on a panel directly connected over Ethernet or via a SIMATIC CPU which is connected to a panel.

8.4.31 Firmware version SecureDisplay

The version of the SecureDisplay software is entered in the "FW-Version SecureDisplay" Parameter. If the version is not entered correctly, a scale value is not output on the SecureDisplay, and the display indicates "Start Up".

8.4.32 Minimum display size [%]

The minimum display size defines the smallest zoom factor for the legal trade display "SecureDisplay". If the zoom factor for the minimum display size does not correspond to the smallest zoom factor stored in the "DisplayCali.xlm" file in the display unit, the weight value is hidden and the text "Start Up" is displayed.

8.5 Calibration procedure

8.5.1 Calibration with calibration weights

The incoming analog measured value from the load cells is converted into a digital value in an analog-to-digital converter. A weight is calculated using this digital value. This weight is then used by all weighing module functions for messages and for determining the status.

The characteristic curve of the measuring system must be defined before the weight can be calculated from the digital value. In the simplest case, the characteristic curve is defined with points 0 and 1. The first working point (point 0) is defined by the empty scales (no load) at their own weight. The load cells return a voltage measurement to the weighing module as a result of the weight of the scales themselves. Following analog-to-digital conversion of the measured voltage, the zero point is assigned to the digital value (calibration digits for the zero point).

If the scales are loaded with a defined calibration weight (e.g. 50% of the measuring range), the new digital value returned by the analog-to-digital converter is assigned the calibration weight.

The characteristic curve can also be determined with a third point, which must be higher than point 1.

Make sure that the difference between two calibration weights is at least 40 000 digits, as the calibration command may otherwise be rejected.

The calibration procedure involves the following steps:

- Define the calibration weight and other parameters of the DR 3 data record.
- Transfer the DR 3 data record to the scales.
- Trigger "Calibration weight 0 valid" for empty scales.
- Load the scales with the defined calibration weight.
- Trigger "Calibration weight 1 valid".
- Transfer data record DR 3 from the scales to SOWATOOL and save the data on a data medium.

You must follow the correct calibration sequence with increasing calibration weights.

Load cell characteristic value	Digits (approx.) at nominal load
1 mV/V	1 000 000
2 mV/V	2 000 000
4 mV/V	4 000 000

The diagram below illustrates the relationship between calibration digits and the calibration weight.

8.5 Calibration procedure

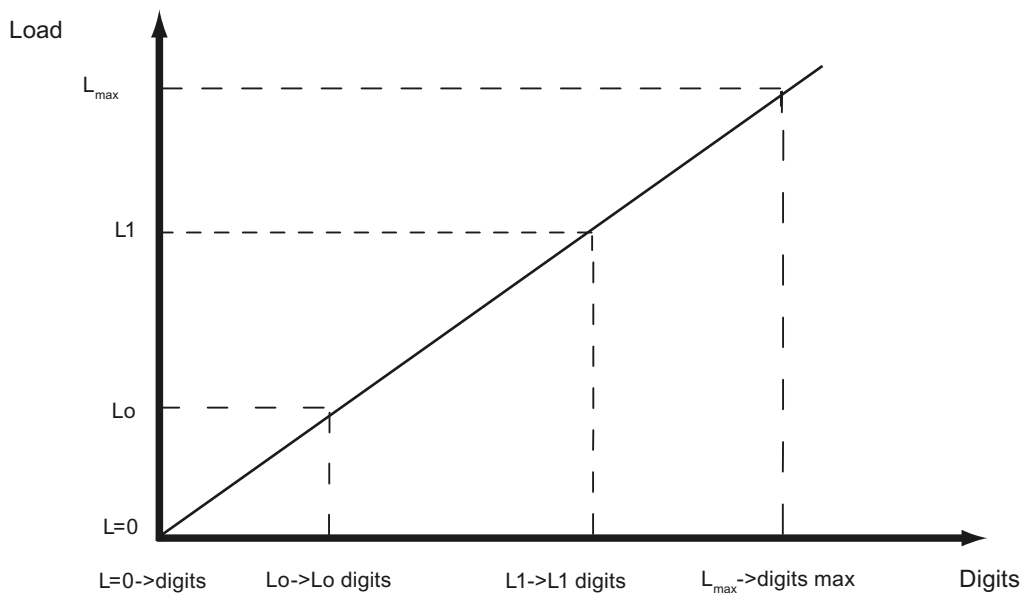

Figure 8-3 Calibration digits and calibration weight

Load	Comment	Load	Digits
L=0	100 kg load cell (2 mV/V) not loaded		Approx. 0
L0	Mechanical installation on load cell (dead load)	25 kg	Approx. 500 000
L1	Calibration weight 1 placed on-to scale	e.g. 60 kg	Approx. 1 200 000
L _{max}	Nominal weight of load cell	100 kg	2 000 000
L _{max} +10%	Rated weight + approx. 10 %	Approx. 110 kg	2 200 000

You do not need to perform calibration if the calibration digits and the calibration weights are known to the weighing module described here. They are simply sent to SIWAREX by data record DR 3 and the scales are ready for use immediately.

The SIWATOOL program facilitates rapid calibration.

Following commissioning and calibration, all data records must be read from the weighing module and saved as a scale file.

Identical scales can be put into operation immediately. Connect the PC to the new scales and enable the "Send all data records" function. This transfers the parameters for calibration weights and calibration digits, and the characteristic curve are determined immediately. The same applies when you change a weighing module.

Note

Two working points are usually sufficient for determining the scales' characteristic curve. An additional working point is only required for non-linear systems.

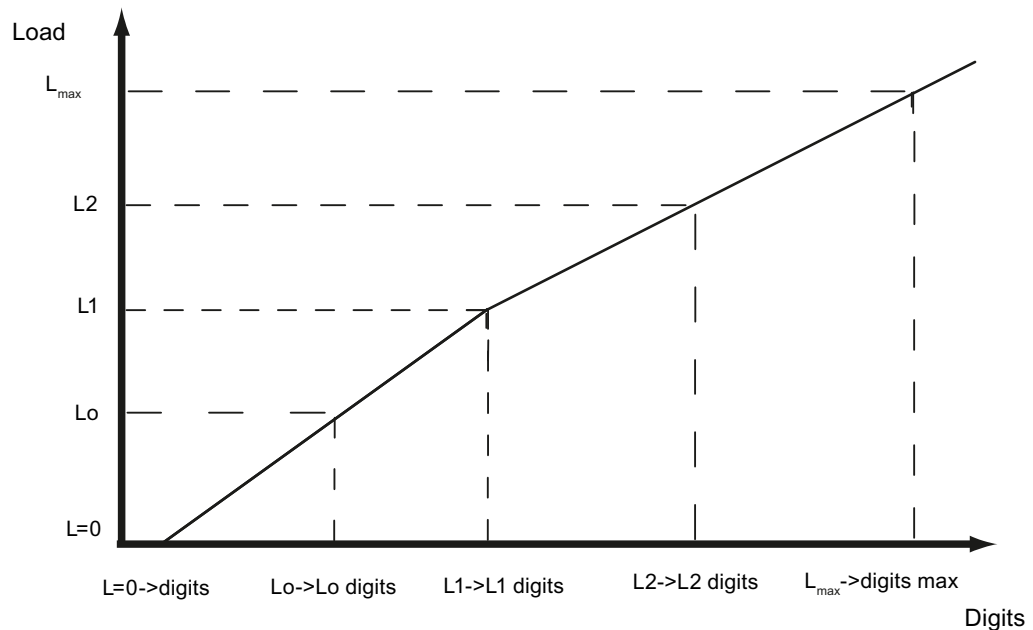

Figure 8-4 Linearizing the scales' characteristic curve

Load	Comment	Load	Digits
L=0	100 kg load cell (2 mV/V) not loaded		Approx. 0
L0	Mechanical installation on load cell (dead load)	e.g. 25 kg	Approx. 500 000
L1	Calibration weight 1 placed on-to scale	e.g. 60 kg	Approx. 1 200 000
L2	Calibration weight 2 placed on-to scale	e.g. 80 kg	Approx. 1 650 000
L _{max}	Nominal weight of load cell	100 kg	Approx. 2 000 000
L _{max} +10 %	Rated weight + approx. 10 %	Approx. 110 kg	Approx. 2 200 000

8.5.2 Automatic calibration

Scales can be rapidly commissioned with automatic calibration. The accuracy of the scale greatly depends on the entered parameters and the mechanical properties of the scale. The best level of accuracy for the scale can be achieved by calibrating with calibration weights.

During initial commissioning with automatic calibration, the module must be reset using the "Load factory settings" or "Load standard parameters" command.

8.6 DR 4 Output of calculated calibration digits

The load cell parameters must subsequently be defined in data record 10. Command 82 "Perform automatic calibration" then uses this data and the currently applied dead load to calculate the characteristic curve of the scale. The characteristic curve is active immediately.

Note

The characteristic curve data in data record 3 active prior to execution of command 82 is directly overwritten.

Automatic calibration requires the following criteria:

- Correct mechanical installation of the scale
- Scale is empty (only mechanical installation (= dead load) present on the cells)
- Installed load cells are evenly loaded
- There are no shunt circuits

8.6 DR 4 Output of calculated calibration digits

Data record DR 4 outputs the digits calculated from the automatic scale calibration and the calibration check. This data record cannot be sent to the scales.

Table 8-2 Assignment of data record 4

Variable	Note	Type	Length (bytes)	Rw	Default	Min.	Max.	Modbus Register
Data record number	Contains no. of data record	USHORT	2	r	4	-	-	1200
Length	Data record length information	USHORT	2	r	28	-	-	1201
Application	Information on which application the DR belongs to	USHORT	2	r	101	-	-	1202
Version identifier	Information on the current data record version	USHORT	2	r	1	1	65635	1203
Calibration digits 0, 1, 2 (calculated) (Page 83)	Calibration digits 0 (calculated): calibration digits calculated by 'automatic calibration'	LONG	4	r	200000	0	1600000	1204
	Calibration digits 1 (calculated): calibration digits calculated by 'automatic calibration'	LONG	4	r	0	0	1600000	1206
	Calibration digits 2 (calculated): calibration digits calculated by 'automatic calibration'	LONG	4	r	0	0	1600000	1208
Reserve 1	Reserve	SHORT	2	r	0	-	-	1210
Reserve 2	Reserve	USHORT	2	r	0	-	-	1211
Reserve 3	Reserve	FLOAT	4	r	0	-	-	1212

8.6.1 Calibration digits 0, 1, 2 (calculated)

The calculation is based on the parameters from DR 10 and is executed using command no. 82 or 83.

8.7 DR 5 zeroing memory

Data record DR 5 displays the current values in the tare memory and the zeroing memory.

In legal trade operation, the data record is not write-protected.

Procedure

- Check all parameters
- Transfer the data record to the scales

Table 8-3 Assignment of data record 5

Variable	Note	Type	Length (bytes)	RW protection	Default	Min.	Max.	Modbus Register
Data record number	Contains no. of data record	USHORT	2	r	5	-	-	1214
Length	Data record length information	USHORT	2	r	40	-	-	1215
Application	Information about which application the DR belongs to	USHORT	2	r	101	-	-	1216
Version identifier	Information about the current data record version	USHORT	2	r	1	1	65635	1217
Effective tare weight - from specification 1, 2 or 3 (Page 84)	Current tare weight (tare setting)	FLOAT	4	rwP	0	0	De- pends on spec- ification in DR 3	1218
Effective tare weight (semi-automatic) (Page 84)	Current tare weight (semi-automatic)	FLOAT	4	rwP	0	0	De- pends on spec- ification in DR 3	1220
Zero by power-on (value when switching on) (Page 84)	Current zero by power-on weight (affected by switch-on)	FLOAT	4	rwP	0	De- pends on specifi- cation in DR 3	De- pends on spec- ification in DR 3	1222
Zero weight (semi-automatic) (Page 85)	Current zero weight (semi-automatic)	FLOAT	4	rwP	0	De- pends on specifi- cation in DR 3	De- pends on spec- ification in DR 3	1224

8.7 DR 5 zeroing memory

Variable	Note	Type	Length (bytes)	RW protection	Default	Min.	Max.	Modbus Register
Current zero tracking weight (Page 85)	Current zero weight (zero adjustment)	FLOAT	4	rwP	0	De- pends on specifi- cation in DR 3	De- pends on spec- ification in DR 3	1226
Dead load (Page 85)	Dead load calculated during auto- matic calibration	FLOAT	4	r	0	De- pends on specifi- cation in DR 3	De- pends on spec- ification in DR 3	1228
Reserve 1	Reserve	SHORT	2	rw	0	-	-	1230
Reserve 2	Reserve	USHORT	2	rw	0	-	-	1231
Reserve 3	Reserve	FLOAT	4	rw	0	-	-	1232

8.7.1 Effective tare weight - from specification 1, 2 or 3

Up to three tare weights can be specified in the DR 15 data record. You activate a specified tare weight with a command (see commands 1013, 1014, 1015). From this point on, the activated tare weight is factored into the weight calculations. The "Delete tare" command deactivates the active tare weight. This does not delete the specification in data record DR 15.

8.7.2 Effective tare weight (semi-automatic)

The corresponding command (see command 1011) applies the current gross weight as the active tare weight. From this point on, the activated tare weight is factored into the weight calculations. The "Delete tare" command deactivates the active tare weight.

8.7.3 Zero by power-on (value when switching on)

If the automatic zero by power-on is configured, the scale is automatically set to "Zero" when the power supply is switched on provided the gross weight is within the defined zero setting limits. The current gross weight is saved as the zero by power-on weight. The zero by power-on weight must be within the specified range (usually $\pm 10\%$).

8.7.4 Zero weight (semi-automatic)

The zero weight command (see command 1001) entered by the user sets the current gross weight to "Zero" provided it is within the defined zero setting limits. The current gross weight is saved as the zero weight. The zeroing weight must be within the specified range (usually +3 / -1 % of the set zero point).

8.7.5 Current zero tracking weight

The current zero tracking weight is recorded in this parameter if automatic zero tracking is activated.

8.7.6 Dead load

The characteristic curve of the scales is determined during calibration. When there is no load, the main display returns "0". The dead load is the weight of the empty scales, i.e. the weight of the scales themselves.

8.8 DR 6 limit value settings

The switch-on and switch-off values for the limits are configured in data record DR 6.

In legal trade operation, the data record is not write-protected.

Procedure

- Check all parameters and modify them as required
- Transfer the data record to the scale

Table 8-4 Assignment of data record 6

Variable	Note	Type	Length (bytes)	Rw	Default	Min.	Max.	Modbus Register
Data record number	Contains no. of data record	USHORT	2	r	6	-	-	1234
Length	Data record length information	USHORT	2	r	60	-	-	1235
Application	Information on which application the DR belongs to	USHORT	2	r	101	-	-	1236
Version identifier	Information on the current data record version	USHORT	2	r	1	1	65635	1237

8.8 DR 6 limit value settings

Variable	Note	Type	Length (bytes)	Rw	Default	Min.	Max.	Modbus Register
Limit reference	Reference value for limits 0: Gross weight in % of max. weighing range 1: Net weight in % of max. weighing range 2: Gross weight, absolute 3: Net weight, absolute	USHORT	2	rw	0	0	1	1238
Reserve 1	Reserve	USHORT	2	rw	0	0	-	1239
Limit value 1 ON (Page 87)	Switch-on point for Limit 1	FLOAT	4	rw	0	maximum number range	maximum number range	1240
Delay time for Limit 1 ON (Page 88)	Time for delayed switch-on of limit value 1 in ms	TIME	4	rw	0	0	maximum number range+	1242
Limit value 1 OFF (Page 87)	Switch-off point for Limit 1	FLOAT	4	rw	0	maximum number range	maximum number range	1244
Delay time for Limit 1 OFF (Page 88)	Time for delayed switch-off of limit value 1 in ms	TIME	4	rw	0	0	maximum number range+	1246
Limit value 2 ON (Page 87)	Switch-on point for Limit 2	FLOAT	4	rw	0	maximum number range	maximum number range	1248
Delay time for Limit 2 ON (Page 88)	Time for delayed switch-on of limit value 2 in ms	TIME	4	rw	0	0	maximum number range+	1250
Limit value 2 OFF (Page 87)	Switch-off point for Limit 2	FLOAT	4	rw	0	maximum number range	maximum number range	1252
Delay time for Limit 2 OFF (Page 88)	Time for delayed switch-off of limit value 2 in ms	TIME	4	rw	0	0	maximum number range+	1254

Variable	Note	Type	Length (bytes)	Rw	Default	Min.	Max.	Modbus Register
Limit value "Empty" ON (Page 88)	Limit value "empty" ON With limit reference 0 and 1: Based on the gross weight in % of max. weighing range With limit reference 2 and 3: Based on absolute gross weight	FLOAT	4	rw	0	maximum number range	maximum number range	1256
Delay time for limit value "Empty" ON (Page 89)	Time for switch-on of "Empty" in ms	TIME	4	rw	0	0	maximum number range+	1258
Reserve 2	Reserve	USHORT	2	rw	0	-	-	1260
Reserve 3	Reserve	USHORT	2	rw	0	-	-	1261
Reserve 4	Reserve	FLOAT	4	rw	0	-	-	1262

8.8.1 Limit reference

Value	Limit values relate to
0	Gross weight in % of max. weighing range
1	Net weight in % of max. weighing range
2	Absolute gross weight
3	Absolute net weight

The limit value "Empty" always relates to gross weight zero.

8.8.2 Limit value 1 ON, limit value 2 ON, limit value 1 OFF, limit value 2 OFF

The switch-on and switch-off points can be specified separately for each limit as a percentage of the measuring range or as absolute values (based on "Limit reference" parameter setting). This allows both minimum and maximum value violation monitoring with hysteresis. A delay time for switch-on and switch-off can also be specified. Either the current net weight or the current gross weight can be selected as the reference value for limits 1 and 2. Negative limits are only possible with input of absolute values. Negative limits as percentage are rejected.

Maximum value monitoring is implemented with the following specifications:

- Switch-on value > switch-off value

Minimum value monitoring is implemented with the following specification:

- Switch-on value < switch-off value

The diagram below illustrates the function of limit values 1 and 2.

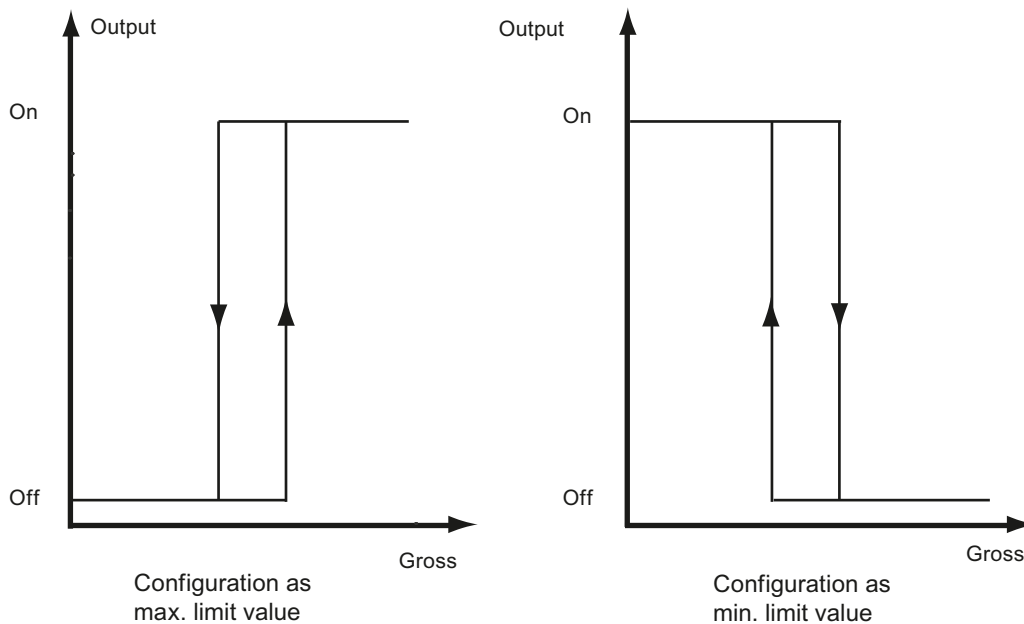

Figure 8-5 Limit value configuration

8.8.3 Delay time for limit value 1 ON, delay time for limit value 2 ON

If the weight reaches the specified switch value, a delay time (defined in ms) is launched. Once the delay time is over, the limit switch changes status provided the weight still reaches the specified switch value.

8.8.4 Delay time for limit value 1 OFF, delay time for limit value 2 OFF

If the weight reaches the specified switch value, a delay time (defined in ms) is launched. Once the delay time is over, the limit switch changes status provided the weight still reaches the specified switch value.

8.8.5 Limit value "Empty" ON

The value for the empty range is a limit value below which the weighing module registers and returns the status "empty". The values are entered as a percentage of the measuring range. The "Empty" limit always refers to the current gross weight in the scale.

The setting, whether absolute or a percentage, also affects the "Empty" limit.

8.8.6 Delay time for limit value "Empty" ON

If the weight reaches the specified switch value for scales status "empty", a delay time (defined in ms) is launched. Once the delay time is over, the switch for "empty" status changes status provided the weight still reaches the specified switch value.

8.9 DR 7 interface parameters

Data record DR 7 contains the parameters for defining the properties of the available I/O modules (digital inputs, digital outputs, analog output, serial ports).

If a port is not used, the default values can be retained.

Procedure

- Change the parameters if necessary
- Transfer the data record to the scale

Table 8-5 Assignment of data record 7

Variable	Note	Type	Length (bytes)	RW	Default	Min.	Max.	Modbus Register
Data record number	Contains no. of data record	USHORT	2	r	7	-	-	1300
Length	Data record length information	USHORT	2	r	60	-	-	1301
Application	Information on which application the DR belongs to	USHORT	2	r	101	-	-	1302
Version identifier	Information on the current data record version	USHORT	2	r	1	1	65635	1303
Assignment for digital input 0, 1, 2, 3 (Page 92)	Assignment for input 0: 0: No command assigned 1 ... 32767: Command is triggered at a rising edge (0->1 transition)	USHORT	2	rw	0	0	32767	1304
	Assignment for input 1: 0: No command assigned 1 ... 32767: Command is triggered at a rising edge (0->1 transition)	USHORT	2	rw	0	0	32767	1305
	Assignment for input 2: 0: No command assigned 1 ... 32767: Command is triggered at a rising edge (0->1 transition)	USHORT	2	rw	0	0	32767	1306
	Assignment for input 3: 0: No command assigned 1 ... 32767: Command is triggered at a rising edge (0->1 transition)	USHORT	2	rw	0	0	32767	1307

8.9 DR 7 interface parameters

Variable	Note	Type	Length (bytes)	RW	Default	Min.	Max.	Modbus Register
Input filtering (hardware setting) (Page 92)	1: 0.2 ms 2: 0.4 ms 3: 0.8 ms 4: 1.6 ms 5: 3.2 ms 6: 6.4 ms 7: 12.8 ms	USHORT	2	rw	5	0	7	1308
Assignment for digital output 0, 1, 2, 3 (Page 93)	Assignment for output 0: 0 ... 32767 of the status flags from byte 0 ... 3 (DR 30) 33: data record 18 34: S7 I/O 100-131: Bit no. of the status flags from bytes 0 ... 3 from data record 30, but inverted 253: Start the cyclic transmission of measured values of the Mettler-Toledo digital load cell (output 0 only) 255: Output always disabled 1000-1031: Operating error 1100-1131: Operating error, inverted 2000-2031: Technological error 2100-2131: Technological error, inverted 3000-3063: Data/command error 3100-3163: Data/command error, inverted	USHORT	2	rw	0	0	3163	1309
	Assignment for output 1: (see Output 0) 254: Stop the cyclic transmission of measured values of the Mettler-Toledo digital load cell	USHORT	2	rw	0	0	3163	1310
	Assignment for output 2: (see Output 0)	USHORT	2	rw	0	0	3163	1311
	Assignment for output 3: (see Output 0)	USHORT	2	rw	0	0	3163	1312
Response of digital outputs to faults or SIMATIC STOP (Page 93)	Response of digital outputs following module fault or CPU STOP: 0: Outputs are switched off 1: Outputs are not switched off, continue 2: The relevant substitute value is activated 3: The outputs are switched on	USHORT	2	rw	0	0	3	1313

Variable	Note	Type	Length (bytes)	RW	Default	Min.	Max.	Modbus Register
Substitute value for DQ 0, 1, 2, 3 following fault or SIMATIC STOP (Page 93)	Substitute value for DQ 1 following fault or SIMATIC CPU STOP	BIT	0	rw	0	0	1	1314.16
	Substitute value for DQ 2 following fault or SIMATIC CPU STOP	BIT	0	rw	0	0	1	1314.15
	Substitute value for DQ 3 following fault or SIMATIC CPU STOP	BIT	0	rw	0	0	1	1314.14
	Substitute value for DQ 4 following fault or SIMATIC CPU STOP	BIT	0	rw	0	0	1	1314.13
Bit 4	Reserve	BIT	0	rw	0	0	1	1314.12
Bit 5	Reserve	BIT	0	rw	0	0	1	1314.11
Bit 6	Reserve	BIT	0	rw	0	0	1	1314.10
Bit 7	Reserve	BIT	0	rw	0	0	1	1314.9
Bit 8	Reserve	BIT	0	rw	0	0	1	1314.8
Bit 9	Reserve	BIT	0	rw	0	0	1	1314.7
Bit 10	Reserve	BIT	0	rw	0	0	1	1314.6
Bit 11	Reserve	BIT	0	rw	0	0	1	1314.5
Bit 12	Reserve	BIT	0	rw	0	0	1	1314.4
Bit 13	Reserve	BIT	0	rw	0	0	1	1314.3
Bit 14	Reserve	BIT	0	rw	0	0	1	1314.2
Bit 15	Reserve	BIT	2	rw	0	0	1	1314.1
Analog output range (Page 94)	0: 0 ... 20 mA 1: 4 ... 20 mA	USHORT	2	rw	0	0	1	1315
Analog output source (Page 94)	Basis of analog value output: 0 = G/N value 1 = Gross 2 = Net 3 = Ext. specification, DR 17 4 = Ext. specification, S7 interface	USHORT	2	rw	2	0	4	1316
Response of analog output to faults or SIMATIC STOP (Page 95)	0: Switch off 1: Continue 2: Output configured output value 3: Output maximum value (24 mA, NAMUR)	USHORT	2	rw	0	0	3	1317
Start value for the analog output (Page 95)	Value at which 0 ...4 mA is to be output	FLOAT	4	rw	0	maximum weight	maximum weight	1318
End value for the analog output (Page 95)	Value at which 20 mA is to be output	FLOAT	4	rw	0	maximum weight	maximum weight	1320
Output value following fault or SIMATIC STOP (Page 95)	Value to be output when the OutDis signal is enabled (in mA)	FLOAT	4	rw	0	0	24	1322

8.9 DR 7 interface parameters

Variable	Note	Type	Length (bytes)	RW	Default	Min.	Max.	Modbus Register
Trace recording cycle (Page 95)	1: 10 ms 10: 100 ms 100: 1 s 1 000: 10 s	USHORT	2	rw	1	1	1000	1324
Trace memory type, bit 0	0: Trace recording runs as a circular buffer 1: Trace is stopped when the trace memory is full	BIT	0	rw	0	0	1	1325.16
Bit 1	Reserve	BIT	0	rw	0	0	1	1325.15
Bit 2	Reserve	BIT	0	rw	0	0	1	1325.14
Bit 3	Reserve	BIT	0	rw	0	0	1	1325.13
Bit 4	Reserve	BIT	0	rw	0	0	1	1325.12
Bit 5	Reserve	BIT	0	rw	0	0	1	1325.11
Bit 6	Reserve	BIT	0	rw	0	0	1	1325.10
Bit 7	Reserve	BIT	1	rw	0	0	1	1325.9
Bit 8	Reserve	BIT	0	rw	0	0	1	1325.8
Bit 9	Reserve	BIT	0	rw	0	0	1	1325.7
Bit 10	Reserve	BIT	0	rw	0	0	1	1325.6
Bit 11	Reserve	BIT	0	rw	0	0	1	1325.5
Bit 12	Reserve	BIT	0	rw	0	0	1	1325.4
Bit 13	Reserve	BIT	0	rw	0	0	1	1325.3
Bit 14	Reserve	BIT	0	rw	0	0	1	1325.2
Bit 15	Reserve	BIT	1	rw	0	0	1	1325.1
Reserve 1	Reserve	LONG	4	rw	0	0	-	1326
Reserve 2	Reserve	FLOAT	4	rw	0	0	-	1328

8.9.1 Assignment for digital input 0, 1, 2, 3

A command trigger can be assigned to a digital input. The assignment is made with the command number: → Command lists (Page 141).

Assignment for input 0, 1, 2, 3:

Value	Assignment
0	Not assigned
1 ... 32767	Command triggered by a rising edge (0 -> 1 transition)

8.9.2 Input filtering (hardware setting)

To ensure that the inputs do not respond too quickly to the signal change, a minimum signal pending time can be specified. The pending signal is not processed further until this time has elapsed.

8.9.3 Assignment for digital output 0, 1, 2, 3

You can assign the digital outputs different functions. The output of the scale status or the error messages as well as additional functions as listed in the following table are available for selection. This is done on the basis of the bit number.

Assignment for output 0, 1, 2, 3:

Value	Function of the digital output
0 - 31	Bit no. of the status flags from byte 0 .. 3 from data record 30
33	Control of output via data record 18
34	Control of output via SIMATIC S7 I/O
100-131	Bit no. of the status flag from byte 0 .. 3 from data record 30, but inverted
253	Only for digital output 1: Start the cyclic transmission of measured values of the WM type Mettler-Toledo digital load cell
254	Only for digital output 2: Stop the cyclic transmission of measured values of the WM type Mettler-Toledo digital load cell
255	Output always disabled
1000-1031	Operating error
1100-1131	Operating error, inverted
2000-2031	Technological error
2100-2131	Technological error, inverted
3000-3063	Data or command error
3100-3163	Data/command error, inverted

8.9.4 Response of digital outputs to faults or SIMATIC STOP

This parameter allows you to define the response of the digital outputs following a fault of the SIWAREX module or SIMATIC STOP.

Value	Response
0	Outputs are switched off
1	Outputs are not switched off (continue)
2	The relevant substitute value is activated
3	Outputs are switched on

8.9.5 Substitute value for DQ 0, 1, 2, 3 following fault or SIMATIC STOP

The outputs are usually reset following a module fault (operating error) or SIMATIC CPU STOP. This response is the default setting.

If an output is to be set following a fault, this response is defined using this parameter. The "Response of digital outputs to fault or SIMATIC STOP" parameter must also be set to "Output substitute value".

The substitute value definition is then valid.

Examples

Table 8-6 Bit 0 defines digital output 1 (DQ 1)

Value of bit 0	Value of DQ 1 following fault
0	0
1	1

Table 8-7 Bit 1 defines digital output 2 (DQ 2)

Value of bit 2	Value of DQ 2 following fault
0	0
1	1

NOTICE

Risk to the plant

If an output is set following a fault (operating error), this can pose a risk for the plant. Ensure that the parameters are correctly set.

8.9.6 Analog output range

This parameter is used to define the range of the output current.

Value	Output current
0	0 ... 20 mA
1	4 ... 20 mA

8.9.7 Analog output source

The analog output can be used for a range of purposes. This parameter defines the tag that controls the analog output.

Value	Basis for the analog output
0	Gross / net value
1	Gross value
2	Net value
3	External specification, DR 17 (Specified in mA)
4	Via SIMATIC S7 I/O modules

8.9.8 Response of analog output to faults or SIMATIC STOP

This parameter defines the response of the analog output following a fault of the SIWAREX module or SIMATIC STOP.

Value	Response
0	Switch off
1	Continue
2	Output configured output value, e.g. 3.5 mA
3	Output maximum value (24 mA, NAMUR)

8.9.9 Start value for the analog output

This parameter defines the specified value at which 0 or 4 mA is output. The value can be greater or less than the end value.

8.9.10 End value for the analog output

This parameter defines the specified value at which 20 mA is output. The value can be greater or less than the start value.

8.9.11 Output value following fault or SIMATIC STOP

The default settings set the analog output to the defined value following a module fault (operating error) or upon SIMATIC CPU STOP.

If the analog output is, for example, to be set to 3.5 mA following a fault, this is defined with this parameter. The current value to be output is entered.

NOTICE
System can be switched to unsafe state
If the analog output is to be set to a given value following a fault (operating error), you must ensure that this poses no danger.

8.9.12 Trace recording cycle

The trace function is used for the continuous recording of measured values. The recording rate is defined with the parameter.

Value	Response
1	Recording every 10 ms
10	Recording every 100 ms

8.10 DR 8 date and time

Value	Response
100	Recording every second
1 000	Recording every 10 s

8.9.13 Trace storage method

This parameter is used to specify the response of the trace memory.

Value	Response
0	Trace recording runs as circulating memory
1	Trace is stopped when the trace memory is full

8.10 DR 8 date and time

The weighing module has its own hardware clock. The current date and time is specified or read using data record DR 8. The clock is buffered by a capacitor and can continue to function without power for around 70 hours. If you are using the Modbus protocol, data record DR 48 must be used for the date and time.

Procedure

- Set the date and time
- Transfer the data record to the scales

Table 8-8 Assignment of data record 8

Variable	Note	Type	Length (bytes)	Rw	Default	Min.	Max.	Modbus registers
Data record number	Contains no. of data record	USHORT	2	r	8	-	-	1330
Length	Data record length information	USHORT	2	r	16	-	-	1331
Application	Information about which application the DR belongs to	USHORT	2	r	101	-	-	1332
Version identifier	Information on current data record version	USHORT	2	r	1	1	65635	1333
Date and time	SIMATIC DTL format	DTL	12	rw	DTL#19 70-01-0 1-00:00 :00.0	-	-	1334

8.11 DR 9 module information

No entries can be made in data record DR 9. This data record provides information on the inner workings of the SIWAREX module. This information is used to identify the module at the manufacturer plant (e.g. in the event of repairs). The entries in the data record are of no importance to the user for operation.

Table 8-9 Assignment of data record 9

Variable	Note	Type	Length (bytes)	Rw	Default	Min.	Max.	Modbus registers
Data record number	Contains no. of data record	USHORT	2	r	9	-	-	1340
Length	Data record length information	USHORT	2	r	68	-	-	1341
Application	Information on which application the DR belongs to	USHORT	2	r	101	-	-	1342
Version identifier	Information on the current data record version	USHORT	2	r	1	1	65635	1343
Order No. - header	Maximum and current string length for the order number	UBYTE[2]	2	r	16.16	-	-	1344
Order No.	Order number of the module 7MH ..	CHAR[16]	16	r	"7MH ..."	-	-	1345
Serial number - header	String header	UBYTE[2]	2	r	12,12	-	-	1352
Serial number	Serial number "XXX00001"	CHAR[12]	12	r	" "	-	-	1353
Firmware type - header	String header	UBYTE[2]	2	r	2.2	-	-	1359
Firmware type	Reference V - Release B - Test etc.	CHAR[2]	2	r	'V '	-	-	1360
FW - Version - 1st digit	Version 1.	USHORT	2	r	0	-	-	1361
FW - Version - 2nd digit	Version 2.	USHORT	2	r	0	-	-	1362
FW - Version - 3rd digit	Version 3.	USHORT	2	r	0	-	-	1363
Hardware version number	ES hardware version number (e.g. 03)	USHORT	2	r	1	-	-	1364
OS version header	String header	UBYTE[2]	2	r	1.1	-	-	1365
OS version (loader) - designation	Reference V - Release B - Test etc.	CHAR[2]	2	r	'V '	-	-	1366
OS version (loader) - designation	e.g. version n	USHORT	2	r	'V '	-	-	1367
DRAM memory	Flash memory	USHORT	2	r	0	-	-	1368
Flash memory	MRAM memory	USHORT	2	r	0	-	-	1369

8.12 DR 10 load cell parameters

Variable	Note	Type	Length (bytes)	Rw	Default	Min.	Max.	Modbus registers
MRAM memory	Memory type	USHORT	2	r	0	-	-	1370
Reserve 1	0	FLOAT	4	r	0	-	-	1371

8.12 DR 10 load cell parameters

The parameters of the analog load cells must be checked prior to the automatic calibration and modified if necessary. Only the parameters identified by bold font and asterisk (*) need be entered.

Procedure

- Check the parameters and modify them as required
- Transfer the data record to the scales
- Adjust the scales

Table 8-10 Assignment of data record 10

Variable	Note	Type	Length (bytes)	Rw	Default	Min.	Max.	Modbus registers
Data record number	Contains no. of data record	USHORT	2	r	10	-	-	1400
Length	Data record length information	USHORT	2	r	44	-	-	1401
Application	Information about which application the DR belongs to	USHORT	2	r	101	-	-	1402
Version identifier	Information on current data record version	USHORT	2	r	1	1	65635	1403
Number of load cells ¹⁾	Number of analog load cells (internal variable)	USHORT	2	rw	1	1	6	1404
50/60 Hz toggling (Page 99)	50/60 Hz toggling	USHORT	2	rw	0	0	1	1405
Number of support points (Page 99) ¹⁾	Number of support points	USHORT	2	rw	0	0	8	1406
	Reserve	USHORT	2	rw	0	0	0	1407
Load cell characteristic value (Page 99) ¹⁾	Characteristic value of the load cell (n) [mV/V], the mean value is used if there is more than one cell.	FLOAT	4	rw	2	>0.1	10	1408
Zero point offset ¹⁾	Zero point offset in uV/V, the mean value is used if there is more than one cell (internal tag).	FLOAT	4	rw	0	-1000	1000	1410
Rated load of a load cell (Page 99) ¹⁾	Rated load of a load cell	FLOAT	4	rw	60	-	-	1412
Reserve	Reserve	FLOAT	4	rw	0	-	-	1414

Variable	Note	Type	Length (bytes)	Rw	Default	Min.	Max.	Modbus registers
Reserve	Reserve	FLOAT	4	rw	0	-	-	1416
Reserve 2	Reserve	SHORT	2	rw	0	-	-	1418
Reserve 3	Reserve	USHORT	2	rw	0	-	-	1419
Reserve 4	Reserve	FLOAT	4	rw	0	-	-	1420

¹⁾ Parameter for calculation of calibration points with theoretical calibration

8.12.1 50/60 Hz toggling

To improve the suppression of faults caused by the supply network, you can specify the network frequency for signal filtering.

8.12.2 Number of support points

If no anchor points are used, the number of support points is equal to the number of load cells.

If anchor points are used in addition to load cells, the number of support points is equal to the total number of load cells and fixed support points.

8.12.3 Load cell characteristic value

The load cell characteristic value is required to correctly interpret the output voltage from the load cell. This specification is also necessary for determining load cell overload. The exact value can be entered if the measurement log for the load cell is available. The mean value can be entered if there is more than one load cell.

Example

Characteristic value = 2.018 mV/V

8.12.4 Rated load of a load cell

The rated load of a load cell is required for checking the maximum weighing range of the scales. The rated load is entered in the specified units of weight.

8.13 DR 12 Ethernet parameters

To integrate the SIWAREX module into an Ethernet network, configure the Ethernet parameters.

Table 8-11 Assignment of data record 12

Variable	Note	Type	Length (bytes)	Rw	Default	Min.	Max.	Modbus registers
Data record number	Contains no. of data record	USHORT	2	r	12	-	-	1500
Length	Data record length information	USHORT	2	r	116	-	-	1501
Application	Information about which application the DR belongs to	USHORT	2	r	101	-	-	1502
Version identifier	Information on current data record version	USHORT	2	r	1	1	65635	1503
Device MAC address (Page 102)	Device MAC address 1	USHORT	2	r		0	FF	1504
	Device MAC address 2	USHORT	2	r		0	FF	1505
	Device MAC address 3	USHORT	2	r		0	FF	1506
	Device MAC address 4	USHORT	2	r		0	FF	1507
	Device MAC address 5	USHORT	2	r		0	FF	1508
	Device MAC address 6	USHORT	2	r		0	FF	1509
Port MAC address (Page 102)	Port MAC address 1	USHORT	2	r		0	FF	1510
	Port MAC address 2	USHORT	2	r		0	FF	1511
	Port MAC address 3	USHORT	2	r		0	FF	1512
	Port MAC address 4	USHORT	2	r		0	FF	1513
	Port MAC address 5	USHORT	2	r		0	FF	1514
	Port MAC address 6	USHORT	2	r		0	FF	1515
IP address (Page 102)	IP address x.n.n.n	USHORT	2	RW	192	0	255	1516
	IP address n.x.n.n	USHORT	2	RW	168	0	255	1517
	IP address n.n.x.n	USHORT	2	RW	0	0	255	1518
	IP address n.n.n.x	USHORT	2	RW	21	0	255	1519
Subnet mask (Page 102)	Subnet mask x.n.n.n	USHORT	2	RW	255	0	255	1520
	Subnet mask n.x.n.n	USHORT	2	RW	255	0	255	1521
	Subnet mask n.n.x.n	USHORT	2	RW	255	0	255	1522
	Subnet mask n.n.n.x	USHORT	2	RW	0	0	255	1523
Gateway (Page 102)	Gateway x.n.n.n	USHORT	2	RW	192	0	255	1524
	Gateway n.x.n.n	USHORT	2	RW	168	0	255	1525
	Gateway n.n.x.n	USHORT	2	RW	0	0	255	1526
	Gateway n.n.n.x	USHORT	2	RW	21	0	255	1527
Device name (Page 102)	Current device name header	UBYTE[2]	2	rw				1528
	Current device name	CHAR[32]	32	RW	" "			1529

Variable	Note	Type	Length (bytes)	Rw	Default	Min.	Max.	Modbus registers
Byte swap for text fields (Page 103) (MODBUS TCP port 502)	0: Yes 1: No	SHORT	2	RW	0	0	1	1545.16
Byte swap for 16-bit values (Page 103) (MODBUS TCP port 502)	0: Big endian (MSB first) 1: Little endian (LSB first)	SHORT	2	rw	0	0	1	1545.15
Byte swap for 32-bit values (Page 103) (MODBUS TCP port 502)	0: Big endian (MSB first) 1: Little endian (LSB first)	SHORT	2	RW	0	0	1	1545.14
Word swap for 32-bit values (Page 103) (MODBUS TCP port 502)	0: Little endian (LSB first) 1: Big endian (MSB first)	SHORT	2	RW	0	0	1	1545.13
Bit 4	Reserve	SHORT	2	RW	0	0	1	1545.12
Bit 5	Reserve	SHORT	2	RW	0	0	1	1545.11
Bit 6	Reserve	SHORT	2	RW	0	0	1	1545.10
Deactivate MODBUS TCP port 502	0: Port is active 1: Port is deactivated	SHORT	2	RW	0	0	1	1545.9
Byte swap for text fields (Page 103) (MODBUS TCP port 503)	0: Yes 1: No	SHORT	2	RW	0	0	1	1545.8
Byte swap for 16-bit values (Page 103) (MODBUS TCP port 503)	0: Big endian (MSB first) 1: Little endian (LSB first)	SHORT	2	RW	0	0	1	1545.7
Byte swap for 32-bit values (Page 103) (MODBUS TCP port 503)	0: Big endian (MSB first) 1: Little endian (LSB first)	SHORT	2	RW	0	0	1	1545.6
Word swap for 32-bit values (Page 103) (MODBUS TCP port 503)	0: Little endian (LSB first) 1: Big endian (MSB first)	SHORT	2	RW	0	0	1	1545.5
Bit 4	Reserve	SHORT	2	RW	0	0	1	1545.4
Bit 5	Reserve	SHORT	2	RW	0	0	1	1545.3
Bit 6	Reserve	SHORT	2	RW	0	0	1	1545.2

Variable	Note	Type	Length (bytes)	Rw	Default	Min.	Max.	Modbus registers
Deactivate MODBUS TCP port 503 (Page 103)	0: Port is active 1: Port is deactivated	SHORT	2	RW	0	0	1	1545.1
Reserve 2	Reserve	FLOAT	4	r	0	-	-	1546
Reserve 3	Reserve	FLOAT	4	r	0	-	-	1548

¹⁾ Defines the format used for transfer over the Ethernet port (MODBUS TCP IP).

8.13.1 Device MAC address

Each SIWAREX module has a unique MAC address. This MAC address cannot be changed by the user.

8.13.2 Port MAC address

Each SIWAREX module has a unique MAC port address. This MAC address cannot be changed by the user.

8.13.3 IP address

Assign the IP address using the Primary Setup Tool, SIWATOOL, or via SIMATIC (see section "IP address for SIWAREX (Page 59)").

8.13.4 Subnet mask

Assign the subnet mask of your network.

8.13.5 Gateway

If a gateway is used between the SIWAREX WP231 and the communication partner, enter the gateway address here.

If a gateway is not present, enter the IP address of the SIWAREX module.

8.13.6 Device name

This parameter can be used to assign a name to the weighing module in the Ethernet network. The length of the name is limited to 32 characters. Empty spaces must be filled by "x".

8.13.7 Byte/Word swap options

Defines the format used for transfer over the Ethernet interface (MODBUS TCP IP).

8.14 DR 13 RS485 parameters

The parameters which define the response of the RS485 interface are specified in data record DR 13. If the interface is not used, keep the default values.

If the interface is not used, the default values can be retained.

Procedure

- Check the parameters and modify them as required.
- Transfer the data record to the scale.

Table 8-12 Assignment of data record 13

Variable	Note	Type	Length (bytes)	Rw	Default	Min.	Max.	Modbus registers
Data record number	Contains no. of data record	USHORT	2	r	13	-	-	1558
Length	Data record length information	USHORT	2	r	24	-	-	1559
Application	Information on which application the data record belongs to	USHORT	2	r	101	-	-	1560
Version identifier	Information on the current data record version	USHORT	2	r	1	1	65635	1561
RS485 protocol (Page 105)	0: No protocol 1: MODBUS RTU 2: SIEBERT display 3: Digital load cell Mettler-Toledo type WMS/WMH 4: Digital load cell Mettler-Toledo type PBK9-APW/PFK9-APW 5: Digital load cell Wipotec 6: SIWAREX DB	USHORT	2	rw	1	0	2	1562
RS485 baud rate (Page 105)	0: 1 200 bps 1: 2 400 bps 2: 9 600 bps 3: 19 200 bps 4: 38 400 bps (for digital load cell) 5: 57 600 bps 6: 115 200 bps (for SIWAREX DB)	USHORT	2	rw	3	0	6	1563
RS485 character parity (Page 105)	Character parity 0: even (for SIWAREX DB and digital load cell Mettler-Toledo) 1: odd (digital load cell Wipotec)	BIT	0	rw	0	0	1	1564.16

Scale parameters and functions

8.14 DR 13 RS485 parameters

Variable	Note	Type	Length (bytes)	Rw	Default	Min.	Max.	Modbus registers
RS485 number of data bits (Page 105)	Number of data bits per character 0: 7 data bits (for digital load cell from Mettler-Toledo) 1: 8 bits (for SIWAREX DB and digital load cell Wipotec)	BIT	0	rw	1	0	1	1564.15
RS485 number of stop bits (Page 105)	Number of stop bits 0: 1 stop bit for SIWAREX DB and digital load cells 1: 2 stop bits	BIT	0	rw	0	0	1	1564.14
Bit 3	Reserve	BIT	0	rw	0	0	1	1564.13
Bit 4	Reserve	BIT	0	rw	0	0	1	1564.12
Bit 5	Reserve	BIT	0	rw	0	0	1	1564.11
Bit 6	Reserve	BIT	0	rw	0	0	1	1564.10
Bit 7	Reserve	BIT	0	rw	0	0	1	1564.9
Byte swap for text fields (Page 105)	0: Yes 1: No	BIT	0	rw	0	0	1	1564.8
Byte swap for 16-bit values (Page 105)	0: Big endian (MSB first) 1: Little endian (LSB first)	BIT	0	rw	0	0	1	1564.7
Byte swap for 32-bit values (Page 105)	0: Big endian (MSB first) 1: Little endian (LSB first)	BIT	0	rw	0	0	1	1564.6
Word swap for 32-bit values (Page 105)	0: Little endian (LSB first) 1: Big endian (MSB first)	BIT	0	rw	0	0	1	1564.5
Bit 12	Reserve	BIT	0	rw	0	0	1	1564.4
Bit 13	Reserve	BIT	0	rw	0	0	1	1564.3
Bit 14	Reserve	BIT	0	rw	0	0	1	1564.2
Bit 15	Reserve	BIT	2	rw	0	0	1	1564.1
RS485 Modbus address (Page 105)	Modbus RTU address of the module	USHORT	2	rw	20	1	255	1565
Decimal place for Siebert indicator (Page 105)	Decimal place for Siebert display	SHORT	2	rw	0	-	-	1566
MODBUS RTU response delay (Page 105)	Delay time for response for MODBUS RTU in ms (RS485), with connection of digital load cell monitoring time load cell telegram	USHORT	2	rw	0	-	-	1567
Reserve 3	Reserve	FLOAT	4	rw	0	-	-	1568

¹⁾ Defines the format used for transfer over the Ethernet port (MODBUS TCP IP).

8.14.1 RS485 protocol

This parameter defines the protocol for communication via the RS485 interface.

8.14.2 RS485 baud rate

This parameter defines the baud rate for the RS485 interface.

8.14.3 RS485 character parity

This parameter defines the character parity for the RS485 interface.

8.14.4 RS485 number of data bits

This parameter defines the number of data bits for the RS485 interface.

8.14.5 RS485 number of stop bits

This parameter defines the number of stop bits for the RS485 interface.

8.14.6 Byte/Word swap options

Defines the format used for transfer over the Ethernet interface (MODBUS TCP IP).

8.14.7 RS485 Modbus address

This parameter defines the Modbus address (1 to 230) for communication via the RS485 interface with the Modbus protocol.

8.14.8 Decimal place for Siebert indicator

A fixed decimal place must be specified if a Siebert indicator is used. The following values are permitted: 0 ... 4

8.14.9 MODBUS RTU response delay

This parameter defines the delay of a response to a data request by the MODBUS RTU master (in ms).

8.15 DR 14 SIMATIC interface parameters

The parameters which define the response of the SIMATIC interface are specified in data record DR 14. It is possible to define the process values to be output on the basis of the I/O area.

Procedure

- Check the parameters and modify them as required
- Transfer the data record to the scale

Table 8-13 Assignment of data record 14

Variable	Note	Type	Length (bytes)	Rw	Default	Min.	Max.	Modbus registers
Data record number	Contains no. of data record	USHORT	2	r	14	-	-	1570
Length	Data record length information	USHORT	2	r	16	-	-	1571
Application	Information on which application the DR belongs to	USHORT	2	r	101	-	-	1572
Version identifier	Information on the current data record version	USHORT	2	r	1	1	65635	1573
Selection of process value 1, 2 (Page 106)	Selection of process value 1 (S7 I/O interface): Code for the selection of the process variable to be updated	USHORT	2	rw	4	0	10	1574
	Selection of process value 2 (S7 I/O interface): Code for the selection of the process variable to be updated	USHORT	2	rw	6	0	10	1575
Reserve 1	Reserve	SHORT	2	rw	0	0	-	1576
Reserve 2	Reserve	USHORT	2	rw	0	0	-	1577

8.15.1 Selection of process value 1, 2

The weighing module can communicate with an S7-1200 CPU in two ways: Just via the I/O or by reading out complete data records. The I/O is faster and exhibits a higher performance. Two free-definable channels are available in the S7 I/O (process value 1 and process value 2). Users can decide which scale values (see table) are to be made available cyclically at these two parameters of the PLC.

Table 8-14 Selection table for process value 1,2

Process value	Decimal code	From DR	Format
No process selected	0	-	-
Gross process	1	30	FLOAT
Net process	2	30	FLOAT
Tare process	3	30	FLOAT
Legal trade G/N weight	4	30	FLOAT
G/N weight_x10	5	30	FLOAT

Process value	Decimal code	From DR	Format
Legal trade tare weight	6	30	FLOAT
Gross-2-process-value	7	30	FLOAT
Net-2-process-value	8	30	FLOAT
Unfiltered digit value	9	31	LONG
Filtered digit value	10	31	LONG
Filtered digit value 2	11	31	LONG
Refresh counter	12	30	USHORT
Status of analog output, digital outputs, and digital inputs	13	31	WORD, BYTE

Table 8-15 Structure of status of analog output, digital outputs, and digital inputs

Byte 0 of dw_Process-Value1/2	Byte 1 of dw_Process-Value1/2	Byte 2 of dw_Process-Value1/2	Byte 3 of dw_Process-Value1/2
Analog output digits HIGH	Analog output digits LOW	Status of digital outputs	Status of digital inputs
WORD		Bit 0 = status DQ 0	Bit 0 = status DI 0
		Bit 1 = status DQ 1	Bit 1 = status DI 1
		Bit 2 = status DQ 2	Bit 2 = status DI 2
		Bit 3 = status DQ 3	Bit 3 = status DI 3

See also

Information about previous versions (Page 17)

8.16 DR 15 tare settings

Data record DR 15 is used for the external specification of up to 3 tare weights.

Procedure

- Enter the tare weight(s)
- Transfer the data record to the scale
- Enable a tare weight with a command

Table 8-16 Assignment of data record 15

Variable	Note	Type	Length (bytes)	Rw	Default	Min.	Max.	Modbus registers
Data record number	Contains no. of data record	USHORT	2	r	15	-	-	1578
Length	Data record length information	USHORT	2	r	28	-	-	1579

8.17 DR 16 simulation value

Variable	Note	Type	Length (bytes)	Rw	Default	Min.	Max.	Modbus registers
Application	Information on which application the DR belongs to	USHORT	2	r	101	-	-	1580
Version identifier	Information on the current data record version	USHORT	2	r	1	1	65635	1581
Specification of tare weight 1, 2, 3 (Page 108)	Tare setting memory 1	FLOAT	4	rw	0	0	Depends on specification in DR 3	1582
	Tare setting memory 2	FLOAT	4	rw	0	0	Depends on specification in DR 3	1584
	Tare setting memory 3	FLOAT	4	rw	0	0	Depends on specification in DR 3	1586
Reserve 1	Reserve	SHORT	2	rw	0	0	-	1588
Reserve 2	Reserve	USHORT	2	rw	0	0	-	1589
Reserve 3	Reserve	FLOAT	4	rw	0	0	-	1590

8.16.1 Specification of tare weight 1, 2, 3

Up to three tare weights can be entered. If a tare weight is to be applied, it must be enabled with the corresponding command. The tare weights may not exceed the maximum values specified in data record DR 3.

8.17 DR 16 simulation value

Specifying a weight value using data record DR 16 disables the measuring input of the SIWAREX module and "simulates" a weight with the specified value. The SIWAREX module must first be released for simulation mode in DR 3 and then switched to simulation mode with command no. 3.

Procedure

- Release simulation mode in DR 3
- Enter the weight to be simulated
- Transfer the data record to the SIWAREX module
- Start the simulation using command "Weight simulation on (3)"
- Stop the simulation using command "Weight simulation off (4)"

Table 8-17 Assignment of data record 16

Variable	Note	Type	Length (bytes)	Rw	Default	Min.	Max.	Modbus registers
Data record number	Contains no. of data record	USHORT	2	r	16	-	-	1592
Length	Data record length information	USHORT	2	r	16	-	-	1593
Application	Information about which application the data record belongs to	USHORT	2	r	101	-	-	1594
Version identifier	Information about current data record version	USHORT	2	r	1	1	65635	1595
Weight simulation specification (Page 109)	Weight value specification (only relevant if simulation mode is enabled)	FLOAT	4	rw	0	maximum weighing range	maximum weighing range	1596
Reserve 1	Reserve	SHORT	2	rw	0	0	-	1598
Reserve 2	Reserve	USHORT	2	rw	0	0	-	1599

8.17.1 Weight simulation specification

Only use weight simulation values which are within the measuring range of the scales. The word "TEST" is displayed on the main display during simulation and a status bit is set. From the start of simulation onward, all parameterized limits, inputs and outputs etc. refer to the simulation weight.

8.18 DR 17 analog output control specifications

If data record DR 17 is configured as the source for the analog output (see Analog output source (Page 94)), specifying a control output sends a corresponding output current at the analog output.

Procedure

- In data record DR 7, check that "Control by DR17" has been configured as the source for the analog output
- Check the analog output configuration (see Analog output source (Page 94))
- Enter a value in data record DR 17
- Transfer the data record to the scales

8.19 DR 18 digital output control specifications

Table 8-18 Assignment of data record 17

Variable	Note	Type	Length (bytes)	Rw	Default	Min.	Max.	Modbus registers
Data record number	Contains no. of data record	USHORT	2	r	17	-	-	1600
Length	Data record length information	USHORT	2	r	16	-	-	1601
Application	Information about which application the data record belongs to	USHORT	2	r	101	-	-	1602
Version identifier	Information about current data record version	USHORT	2	r	1	1	65635	1603
Analog output specification (Page 110)	Value which is to be output (only relevant if source is "External specification", see DR 7)	FLOAT	4	rw	0	-	-	1604
Reserve 1	Reserve	SHORT	2	rw	0	0	-	1606
Reserve 2	Reserve	USHORT	2	rw	0	0	-	1607

8.18.1 Analog output specification

The value to be entered must be between the start value (Page 95) and the end value (Page 95) of the analog output.

8.19 DR 18 digital output control specifications

If a digital output is defined in data record DR 7 for control with data record DR 18 (see Assignment for digital output 0, 1, 2, 3 (Page 93)), you can control this output with data record DR 18. Transfer is always for all four digital outputs. Only outputs which are configured for control by DR 18 (see DR 7 interface parameters (Page 89)) are enabled or disabled in accordance with the content of data record DR 18.

Procedure

- Check or adapt the desired parameter settings of the digital outputs in data record 7
- Define the value for digital output 0, 1, 2, 3
- Transfer the data record to the scales

Table 8-19 Assignment of data record 18

Variable	Note	Type	Length (bytes)	Rw	Default	Min.	Max.	Modbus registers
Data record number	Contains no. of data record	USHORT	2	r	18	-	-	1608
Length	Data record length information	USHORT	2	r	12	-	-	1609
Application	Information about which application the DR belongs to	USHORT	2	r	101	-	-	1610

Variable	Note	Type	Length (bytes)	Rw	Default	Min.	Max.	Modbus registers
Version identifier	Information on current data record version	USHORT	2	r	1	1	65635	1611
Specification for digital output 0, 1, 2, 3 (Page 111)	Specification for digital output 0=1 - > DA0 output enabled (only applies if output is assigned code 21, see DR 7)	BIT	0	rw	0	0	1	1612.16
	Specification for digital output 1=1 - > DA1 output enabled (only applies if output is assigned code 21, see DR 7)	BIT	0	rw	0	0	1	1612.15
	Specification for digital output 2=1 - > DA2 output enabled (only applies if output is assigned code 21, see DR 7)	BIT	0	rw	0	0	1	1612.14
	Specification for digital output 3=1 - > DA3 output enabled (only applies if output is assigned code 21, see DR 7)	BIT	0	rw	0	0	1	1612.13
Bit 4	Reserve	BIT	0	rw	0	0	1	1612.12
Bit 5	Reserve	BIT	0	rw	0	0	1	1612.11
Bit 6	Reserve	BIT	0	rw	0	0	1	1612.10
Bit 7	Reserve	BIT	0	rw	0	0	1	1612.9
Bit 8	Reserve	BIT	0	rw	0	0	1	1612.8
Bit 9	Reserve	BIT	0	rw	0	0	1	1612.7
Bit 10	Reserve	BIT	0	rw	0	0	1	1612.6
Bit 11	Reserve	BIT	0	rw	0	0	1	1612.5
Bit 12	Reserve	BIT	0	rw	0	0	1	1612.4
Bit 13	Reserve	BIT	0	rw	0	0	1	1612.3
Bit 14	Reserve	BIT	0	rw	0	0	1	1612.2
Bit 15	Reserve	BIT	2	rw	0	0	1	1612.1
Reserve 1	Reserve	USHORT	2	rw	0	-	-	1613

8.19.1 Specification for digital output 0, 1, 2, 3

Digital outputs 0 to 3 can be controlled using data record 18 with this parameter. This function can be used for commissioning purposes, for example.

8.20 DR 30 current process values

Current states and process values in the scales can be monitored using process values and advanced process values from data record DR 31. Monitoring selected data during commissioning is extremely useful as it helps you to optimize parameters.

8.20 DR 30 current process values

Procedure

- Read data record DR 30 cyclically or on a time-triggered basis
- Display/analyze the required tags

It is not always necessary to cyclically read data record DR 30. If the relevant process tags are already selected in data record DR 14 (Page 106), they are immediately transferred via the I/O interface. In this case, these tags and all status bits and messages are accessible without data record communication.

Table 8-20 Assignment of data record 30

Variable	Note	Type	Length (bytes)	Rw	Default	Min.	Max.	Modbus registers
Data record number	Contains no. of data record	USHORT	2	r	30	-	-	3000
Length	Data record length information	USHORT	2	r	60	-	-	3001
Application	Information on which application the data record belongs to	USHORT	2	r	101	-	-	3002
Version identifier	Information on the current data record version	USHORT	2	r	1	1	255	3003
1/4d zero	Set if gross less than $\pm 0.25e$	BIT	2	r	0	-	-	3004.16
9e max	Set if the weight has exceeded the gross weighing range by more than 9 display steps (d)	BIT	0	r	0	-	-	3004.15
Tared	Set if tare memory is not equal to zero	BIT	0	r	0	-	-	3004.14
Manual tare 1 set (pT)	Set if the tare memory is assigned an external specified value 1	BIT	0	r	0	-	-	3004.13
Reserve		BIT	0	r	0	-	-	3004.12
Waiting for standstill	Set if module is waiting for standstill to execute command	BIT	0	r	0	-	-	3004.11
Standstill	Set if standstill condition is met	BIT	0	r	0	-	-	3004.10
		BIT	0	r	0	-	-	3004.9
Empty	Set if "Empty" condition is met	BIT	0	r	0	-	-	3004.8
Limit value 1	Limit value 1 has responded	BIT	0	r	0	-	-	3004.7
Limit value 2	Limit value 2 has responded	BIT	0	r	0	-	-	3004.6
Min violated	Set if min. is violated	BIT	0	r	0	-	-	3004.5
SIWAREX DB – EXC Error	Set if the supply voltage for the load cells is less than 4.7 V	BIT	0	R	0	-	-	3005.15
SIWAREX DB – Impedance warning	Impedance value of the load cells outside the defined range	BIT	0	R	0	-	-	3005.14
SIWAREX DB - Temperature warning	Temperature of SIWAREX DB outside the defined range	BIT	0	R	0	-	-	3005.13
Digital load cell ready	Set if the digital load cell sends valid telegrams	BIT	0	r	0	-	-	3005.12

Variable	Note	Type	Length (bytes)	Rw	Default	Min.	Max.	Modbus registers
Time incorrect	Time incorrect due to empty buffer. Reset the time.	BIT	0	r	0	-	-	3005.11
Trace active	Set if trace is running	BIT	0	r	0	-	-	3005.10
Command error at digit. input	Set with synchronization error by command to digital input	BIT	0	r	0	-	-	3005.9
Calibrated	SIWAREX is calibrated	BIT	0	r	0	-	-	3005.8
Service mode	Service mode is enabled	BIT	0	r	0	-	-	3005.7
Simulation mode	Simulation mode is enabled	BIT	0	r	0	-	-	3005.6
Write protection	Write-protect jumper is enabled	BIT	0	r	0	-	-	3005.5
Analog output disrupted	Analog output fault	BIT	0	r	0	-	-	3005.4
Reserve		BIT	0	r	0	-	-	3005.3
Startup	Startup or restore to recovery point has occurred, deleted after 5 seconds	BIT	0	r	0	-	-	3005.2
Fault status	Operating fault	BIT	0	r	0	-	-	3005.1
1000	Group message "Operating error" present	BIT	2	r	0	-	-	3006.16
Reserve		BIT	0	r	0	-	-	3006.15
1104	Undervoltage	BIT	0	r	0	-	-	3006.14
1105	Load high (Overload)	BIT	0	r	0	-	-	3006.12
1106	Underload	BIT	0	r	0	-	-	3006.11
1002	RAM error	BIT	0	r	0	-	-	3006.10
1102	ADC error	BIT	0	r	0	-	-	3006.9
1005	Reserved	BIT	0	r	0	-	-	3006.8
1003	Checksum error data	BIT	0	r	0	-	-	3006.7
1107	Reserve	BIT	0	r	0	-	-	3006.6
1004	Checksum error program	BIT	0	r	0	-	-	3006.5
Reserve	-	BIT	0	r	0	-	-	3006.4
1001	Watchdog	BIT	0	r	0	-	-	3006.3
Reserve	-	BIT	0	r	0	-	-	3006.2
Reserve	-	BIT	0	r	0	-	-	3006.1
2000	Group message "Technological error" present	BIT	2	0	0	-	-	3007.16
2001	Taring or zeroing timeout	BIT	0	r	0	-	-	3007.15
2002	Trace not possible since a task is still active	BIT	0	r	0	-	-	3007.14
2003	Zeroing not possible	BIT	0	r	0	-	-	3007.13
Gross process weight (Page 114)	Gross weight (process value)	FLOAT	4	r	0	-	-	3008
Net process weight (Page 114)	Net weight (process value)	FLOAT	4	r	0	-	-	3010

8.20 DR 30 current process values

Variable	Note	Type	Length (bytes)	Rw	Default	Min.	Max.	Modbus registers
Tare process weight (Page 114)	Tare weight (process value)	FLOAT	4	r	0	-	-	3012
Gross / net weight (Page 115)	Gross or net weight	FLOAT	4	r	0	-	-	3014
Gross / net weight with increased resolution (x 10) (Page 115)	Legal trade G/N weight with 10x resolution	FLOAT	4	r	0	-	-	3016
Tare weight (Page 115)	Tare	FLOAT	4	r	0	-	-	3018
Gross process weight (commissioning aid) (Page 115)	Gross weight after dig. Filter 2 (process value)	FLOAT	4	r	0	-	-	3020
Net process weight (commissioning aid) (Page 115)	Net weight after dig. Filter 2 (process value)	FLOAT	4	r	0	-	-	3022
Refresh counter for process values (Page 115)	Cycle counter incremented by 1 if weight values have been changed	USHORT	2	r	0	-	-	3024
Reserve 1	Reserve	SHORT	2	r	0	-	-	3025
Last report ID (Page 115)	Last generated report ID	ULONG	4	r	0	-	-	3026
Reserve 3	Reserve	FLOAT	4	r	0	-	-	3028

8.20.1 Gross process weight

The current gross weight. Values are rounded as specified in data record DR 3 with the "Decimal places for process values" (Page 74) parameter.

8.20.2 Net process weight

The current net weight. Values are rounded as specified in data record DR 3 with the "Decimal places for process values" (Page 74) parameter.

8.20.3 Tare process weight

The current tare weight. Values are rounded as specified in data record DR 3 with the "Decimal places for process values" (Page 74) parameter.

8.20.4 Gross / net weight

The current weight for the main display. The resolution corresponds to the scale interval (Page 73) specified in data record DR 3.

8.20.5 Gross / net weight with increased resolution (x 10)

The current weight for the main display in higher resolution. The resolution corresponds to the scale interval specified in data record DR 3 x 10.

8.20.6 Tare weight

The current tare weight (scale interval from DR 3). The resolution corresponds to the scale interval specified in data record DR 3.

8.20.7 Gross process weight (commissioning aid)

The current gross weight. Values are rounded as specified in data record DR 3 with the "Decimal places for process values" (Page 74) parameter.

8.20.8 Net process weight (commissioning aid)

The current net weight. Values are rounded as specified in data record DR 3 with the "Decimal places for process values" (Page 74) parameter.

8.20.9 Refresh counter for process values

Measured values are calculated every 10 ms in the SIWAREX module. A counter is incremented by 1 each time. Once the counter reaches the value 65536, it starts again from zero. The counter can be used as a time stamp for data record DR 30.

8.20.10 Last report ID

The last generated report ID is displayed.

8.21 DR 31 advanced current process values

Current states and process values in the scales can be monitored using advanced process values and process values (DR 30). This data is not required for standard operation of the scales.

8.21 DR 31 advanced current process values

Monitoring selected data during trial operation is extremely useful as it helps you to optimize parameters.

Procedure

- Read data record DR 31
- Display/analyze the required tags

Table 8-21 Assignment of data record 31

Variable	Note	Type	Length (bytes)	Rw	Default	Min.	Max.	Modbus registers
Data record number	Contains no. of data record	USHORT	2	r	31	-	-	3300
Length	Data record length information	USHORT	2	r	32	-	-	3301
Application	Information about which application the data record belongs to	USHORT	2	r	101	-	-	3302
Version identifier	Information about current data record version	USHORT	2	r	1	1	65635	3303
Unfiltered digit value (Page 117)	Unfiltered digit value of AD converters / digital load cells	LONG	4	r	0	-	-	3304
Filtered digit value (Page 117)	Filtered digit value of AD converters or digital load cells after dig. filter 1	LONG	4	r	0	-	-	3306
Filtered digit value (commissioning aid) (Page 117)	Filtered digit value of AD converters or digital load cells after dig. filter 2	LONG	4	r	0	-	-	3308
Reserve		SHORT	2	r	0	-100	100	3310
Digits for analog output (Page 117)	Digit value of the analog output currently being output	USHORT	2	r	0	0	65535	3311
Current status of input 0, 1, 2, 3 (Page 117)	Current status of input 0	BIT	0	r	0	0	1	3312.16
	Current status of input 1	BIT	0	r	0	0	1	3312.15
	Current status of input 2	BIT	0	r	0	0	1	3312.14
	Current status of input 3	BIT	0	r	0	0	1	3312.13
Bit 4	Reserve	BIT	0	r	0	0	1	3312.12
Bit 5	Reserve	BIT	0	r	0	0	1	3312.11
Bit 6	Position of DIP switch 1	BIT	0	r	0	0	1	3312.10
Bit 7	Position of DIP switch 2	BIT	0	r	0	0	1	3312.9
Current status of digital output 0, 1, 2, 3 (Page 117)	Current status of output 0	BIT	0	r	0	0	1	3312.8
	Current status of output 1	BIT	0	r	0	0	1	3312.7
	Current status of output 2	BIT	0	r	0	0	1	3312.6
	Current status of output 3	BIT	0	r	0	0	1	3312.5
Reserve		BIT	0	r	0	0	1	3312.4
Reserve		BIT	0	r	0	0	1	3312.3
Reserve		BIT	0	r	0	0	1	3312.2

Variable	Note	Type	Length (bytes)	Rw	Default	Min.	Max.	Modbus registers
Reserve		BIT	2	r	0	0	1	3312.1
Refresh counter for process values (Page 118)	Refresh counter incremented by 1 if weight values were changed	USHORT	2	r	0	-	-	3313
Current load cell signal in mV (Page 118)	Currently measured load cell signal	FLOAT	4	r	0	-	-	3314

8.21.1 Unfiltered digit value

The unfiltered digit value is the internal measured value immediately before filtering.

8.21.2 Filtered digit value

The filtered digit value is the internal measured value immediately after filtering.

8.21.3 Filtered digit value (commissioning aid)

The filtered digit value is the internal measured value immediately after filtering with the commissioning filter.

8.21.4 Digits for analog output

The current digit value for the digital-to-analog converter for the analog output. The resolution of the analog output is 16 bit.

8.21.5 Current status of input 0, 1, 2, 3

This parameter allows you to check the current status of the digital inputs.

8.21.6 Current status of digital output 0, 1, 2, 3

This parameter allows you to check the current status of the digital outputs.

8.21.7 Refresh counter for process values

Measured values are calculated every 10 ms in the SIWAREX module. A counter is incremented by 1 each time. Once the counter reaches the value 65536, it starts again from zero. The counter can be used as a time stamp for data record DR 30.

8.21.8 Current load cell signal in mV

Display of currently measured signal voltage of the load cell(s) in mV.

8.22 DR 32 display of data and operator errors

Data record DR 32 is used for Modbus communication with a Modbus master. If a function which is used to write to the holding register is completed with an error, the data or operator error reported can be read from data record DR 32. Messages are displayed for at least five seconds and do not need to be acknowledged in the SIWAREX module.

Data record DR 32 does not need to be polled upon positive completion of a function for writing to the SIWAREX register.

Table 8-22 Assignment of data record 32

Variable	Note	Type	Length (bytes)	Rw	Default	Min.	Max.	Modbus registers
Data record number	Contains no. of data record	USHORT	2	r	32	-	-	3500
Length	Data record length information	USHORT	2	r	28	-	-	3501
Application	Information about which application the data record belongs to	USHORT	2	r	101	-	-	3502
Version identifier	Information about current data record version	USHORT	2	r	1	1	65635	3503
5000	Data or operating error exists	BIT		r	0	0	1	3504.16
5001	Command code or data record unknown	BIT		r	0	0	1	3504.15
5002	Command or data change not possible because write protection is active	BIT		r	0	0	1	3504.14
5003	Leaving calibration mode not possible	BIT		r	0	0	1	3504.13
5004	Command or data transmission only available in service mode	BIT		r	0	0	1	3504.12
5005	Command or data transmission not possible because service mode is active	BIT		r	0	0	1	3504.11
5006	Command or data transmission not possible because BUSY	BIT		r	0	0	1	3504.10

Variable	Note	Type	Length (bytes)	Rw	Default	Min.	Max.	Modbus registers
5007	Command or data transmission not possible because module is faulty or ODIS is active	BIT		r	0	0	1	3504.9
Reserve	-	BIT		r	0	0	1	3504.8
Reserve	-	BIT		r	0	0	1	3504.7
5101	Command is not permissible in this operating state	BIT		r	0	0	1	3504.6
5102	Command not possible because not at standstill	BIT		r	0	0	1	3504.5
5104	Command not possible because range is exceeded	BIT		r	0	0	1	3504.4
5105	Load cell parameter not plausible	BIT		r	0	0	1	3504.3
Reserve		BIT		r	0	0	1	3504.2
5107	Shifting characteristic not possible	BIT		r	0	0	1	3504.1
5199	Error in command to DI	BIT		r	0	0	1	3505.11
6002	Recording not possible because weight invalid	BIT		r	0	0	1	3505.5
7000	Permitted number range violated	BIT		r	0	0	1	3506.16
		BIT		r	0	0	1	3506.15
7001	Regulation code unknown	BIT		r	0	0	1	3506.14
7002	Specifications of string lengths not plausible	BIT		r	0	0	1	3506.13
7003	Specification of date / time not plausible	BIT		r	0	0	1	3506.12
7004	Assignment of digital inputs/outputs incorrect	BIT		r	0	0	1	3506.11
7006	Command only possible in test field	BIT		r	0	0	1	3506.10
7007	The calibration weights or calibration digits are not plausible	BIT		r	0	0	1	3506.9
7008	Zeroing/zero setting or tare parameter not plausible	BIT		r	0	0	1	3506.8
7009	Standstill range / standstill wait time not plausible	BIT		r	0	0	1	3506.7
7010	Scale interval / rounding not plausible	BIT		r	0	0	1	3506.6
7011	Filter parameter not plausible	BIT		r	0	0	1	3506.5
7013	Interface assignment for verifiable HMI not plausible	BIT		r	0	0	1	3506.4
Reserve	-	BIT		r	0	0	1	3506.3
Reserve	-	BIT		r	0	0	1	3506.2
7016	Parameter assignment of analog output not plausible	BIT		r	0	0	1	3506.1
7017	MAC address cannot be changed	BIT		r	0	0	1	3607.16
7018	Error in IP mask	BIT		r	0	0	1	3607.15
7019	RS485 parameter error	BIT		r	0	0	1	3607.14

8.22 DR 32 display of data and operator errors

Variable	Note	Type	Length (bytes)	Rw	Default	Min.	Max.	Modbus registers
Reserve	-	USHORT	2	r	0	-	-	3504
Reserve	-	USHORT	2	r	0	-	-	3505
Reserve	-	USHORT	2	r	0	-	-	3506
Reserve	-	USHORT	2	r	0	-	-	3507
Reserve	-	USHORT	2	r	0	-	-	3508
Modbus RTU error code (Page 120)	Synchronous error code for communication at the Modbus RS485 interface	USHORT	2	r	0	-	-	3509
Modbus Ethernet error code (Page 120)	Synchronous error code for communication at the Modbus Ethernet interface	USHORT	2	r	0	-	-	3510
SIWATOOL error code (Page 120)	Synchronous error code for communication at the SIWATOOL interface	USHORT	2	r	0	-	-	3511
Error code following commands at digital input (Page 121)	Synchronous error code caused by command at the DI	USHORT	2	r	0	-	-	3512
Reserve	-	USHORT	2	r	0	-	-	3513

8.22.1 Data and operator errors, bytes 0 to 7

Messages are represented by bits in this area. A set bit means that the corresponding message is activated. The message bit is set following a data or operator error and automatically reset approximately 3 seconds later.

Message bits are analyzed by the operator panel message system.

8.22.2 Modbus RTU error code

The error code is displayed here of the error which was triggered last as a result of a command at the Modbus RTU interface.

8.22.3 Modbus Ethernet error code

The error code is displayed here of the error which was triggered last as a result of a command at the Modbus Ethernet interface.

8.22.4 SIWATOOL error code

The error code is displayed here of the error which was triggered last as a result of a command at the SIWATOOL interface.

8.22.5 Error code following commands at digital input

The error code is displayed here of the error which was triggered last as a result of a command via the digital input.

8.23 DR 34 ASCII main display value

The ASCII weight corresponds to the value on the main display of the scales and can be used for a supplementary display or operating display as well as the legal trade main display. Reading of the current weight for legal trade use is only possible with the special SecureDisplay software.

Table 8-23 Assignment of data record 34

Variable	Note	Type	Length (bytes)	Rw	Default	Min.	Max.	Modbus registers
Data record number	Contains no. of data record	USHORT	2	r	34	-	-	4000
Length	Data record length information	USHORT	2	r	26	-	-	4001
Application	Information about which application the DR belongs to	USHORT	2	r	101	-	-	4002
Version identifier	Information about current data record version	USHORT	2	r	1	1	65635	4003
ASCII display string header	Maximum length and actual length of string	UBYTE[2]	2	r	16,2	-	-	4004
Content of main display as ASCII string (Page 121)	For display of legal-for-trade weight value, increased resolution, etc. (see below)	CHAR[16]	16	r	" "	-	-	4005

8.23.1 Content of main display as ASCII string

The following values can be displayed in non-automatic weighing instruments (NAWI) applications:

Gross process value	From DR 30
Net process value	From DR 30
G/N weight	From DR 0
G/N weight x10	From DR 30
Tare	From DR 30
Gross_2 process value	From DR 30
Firmware version	From DR 9
Current calibration regulation	From DR 9
Serial number of module	From DR 9

Below are some display examples. Commands are used to toggle display values.

8.24 DR 45 protocol request

The values to be displayed are hidden if, for example, a fault is pending or a value is outside the valid display range.

	Value designation		Blank	Display value							Unit of weight (from DR 3)		
Weight (Tare ≠ 0)	NET	•	•	•	•	•	2	2	0	.	5	0	•kg•
Weight (Tare = 0)	B	•	•	•	•	•	-	0	.	0	3	•t••	
Operator error	•	•	•	•	•	•	1	0	.	0	0	3	HIGH
Weight simulation activated	B	•	•	•	•	•	E	r	r	o	r		TEST
Max+9e exceeded	B	•	•	•	•	•	-	0	.	0	3		****
Tare display activated (pt)	p	T	•	1	2	5	6	7	8	.	9	0	•kg•
Tare display activated	T	•	•	•	•	•	5	0	.	5	0		•kg•

NET = net

B = gross

T = tare

pT = preset tare (tare setting active)

S = sum

8.24 DR 45 protocol request

Scale logs can be saved in the internal memory of the SIWAREX. If necessary, a log can be read out calibration-proofed using the SIWATOOL V7 program or the SecureDisplay and its contents checked.

Using data records DR 45/DR 46, you can read all logs into the SIMATIC S7 (not legal-for-trade, only as operating information). The user enters the log ID for the desired log in DR 45 and then sends DR 45 to the SIWAREX. The log is then made available in DR 46 for reading.

Table 8-24 Assignment of data record 45

Variable	Note	Type	Length (bytes)	Rw	Default	Min.	Max.	Modbus registers
Data record number	Contains no. of data record	USHORT	2	r	45			6000
Length	Data record length information	USHORT	2	r	28			6001
Application	Information about which application the DR belongs to	USHORT	2	r	101			6002
Version identifier	Information about current data record version	USHORT	2	r	1	1	65635	6003
Reserve	Reserve	UBYTE[2]	2	rw	12,12			6004
Reserve	Reserve	CHAR[12]	12	rw	" "	-	-	6005
Reserve	Reserve	USHORT	2	rw	0			6011
Protocol ID to be read, decimal	ID of requested protocol entry as decimal value	LONG	4	rw	0	1		6012

8.24.1 Protocol ID to be read

The protocol ID of the protocol to be displayed in data record 46 is entered at this point. If the value is zero, the most recently created protocol is always automatically written to data record 46.

The report ID to be read is also used for reading of the report for legal trade use by means of the SecureDisplay.

8.25 DR 46 protocol contents

Protocol data is provided in data record DR 46. The log memory can hold up to 690,000 entries.

Table 8-25 Assignment of data record 46

Variable	Note	Type	Length (bytes)	Rw	Default	Min.	Max.	Mod-bus registers
Data record number	Contains no. of data record	USHORT	2	r	46			6100
Length	Data record length information	USHORT	2	r	128			6101
Application	Information on which application the DR belongs to	USHORT	2	r	101			6102
Version identifier	Information on the current data record version	USHORT	2	r	1	1	65635	6103
Oldest protocol ID	Oldest protocol ID, 0: No entry available	ULONG	4	r	0	1	4,294,967,295	6104
Newest protocol ID	ID of last saved protocol entry, 0: No entry available	ULONG	4	r	0	1	4,294,967,295	6106
Selected protocol ID, numeric	ID of subsequent protocol entry, 0: No entry available)	ULONG	4	r	0	1	4,294,967,295	6108
Reserve	Reserve	UBYTE[2]	2	r	12,12			6110
Reserve	Reserve	CHAR[12]	12	r	" 0"	" 1"	"4294967295"	6111
Reserve	Reserve	UBYTE[2]	2	r	12,12			6117
Reserve	Reserve	CHAR[12]	12	r	" 0"	" 1"	"4294967295"	6118
Reserve	Reserve	UBYTE[2]	2	r	12,12			6124
Reserve	Reserve	CHAR[12]	12	r	" 0"	" 1"	" 4294967295"	6125
String header for report ID currently selected	String header	UBYTE[2]	2	r	28,28			6131
Gross/net identifier	Gross/net identifier	CHAR[2]	2	r	" "			6132 ^{*1)}
Delimiters	Delimiter (semicolon)	CHAR	1	r	","			
G/N weight	G/N weight	CHAR[8]	8	r	" "			

Variable	Note	Type	Length (bytes)	Rw	Default	Min.	Max.	Modbus registers
Delimiters	Delimiter (semicolon)	CHAR	1	r	","			
Weight unit	Weight unit	CHAR[4]	4	r	" "			
Delimiters	Delimiter (semicolon)	CHAR	1	r	","			
Tare identifier	Tare identifier No entry: Scale was not tared when logging T: Scale was tared with manual tare when logging pT: Scale was tared with tare specification from DR15 for logging	CHAR[2]	2	r	" "			
Delimiters	Delimiter (semicolon)	CHAR	1	r	","			
Tare	Currently effective tare	CHAR[8]	8	r	" "			
String header for checksum	String header for checksum	UBYTE[2]	2	r	4.4			
CRC16 checksum	Checksum of selected protocol	CHAR[4]	4	r	"0000"			6146
String header for date	String header for date	UBYTE[2]	2	r	10,10			6147
Date	Date	CHAR[10]	10	r	"2012-03-31"			6150
String header for time	String header for time	UBYTE[2]	2	r	8.8			6155
Time	Time	CHAR[8]	8	r	"23:59:59"			6156
String header for supplementary information	String header for supplementary information	UBYTE[2]	2	r	2.2			6100
Supplementary info	Currently not used	CHAR[4]	4	r	" "			6161
Reserve	Reserve	USHORT	2	r	0			6163

¹⁾ The protocol string is read out as a unit over Modbus (Modbus registers 6132 ... 6145)

8.25.1 Oldest protocol ID

The ID of the first saved protocol is displayed here.

8.25.2 Newest protocol ID

The ID of the last saved protocol is displayed here.

8.25.3 Selected protocol ID, numeric

The ID of the protocol requested in data record 45 and shown in data record 46 is displayed here.

8.25.4 Gross / net identifier

The identifier provides information on whether a gross weight or net weight was logged for the selected ID.

8.25.5 G/N weight

The G/N weight of the selected log is displayed here.

8.25.6 Unit of weight

The unit of weight of the selected log is displayed here.

8.25.7 Tare identification

The tare identification of the selected log is displayed here. The identification shows whether the tare has been entered by the user (semi-automatically) or whether it is a specified tare.

8.25.8 Date, time

The date and time of the selected log are displayed here.

8.26 DR 47 logbook

The changes in the SecureDisplay software versions are recorded in the logbook. If the SIWAREX has established communication with the SecureDisplay, SIWAREX checks whether the software version of the SecureDisplay has changed. Changes are recorded in the logbook. In this manner a more recent version of the SecureDisplay can also be used during operation requiring calibration without the calibration being violated.

8.26 DR 47 logbook

The logbook entries are in data record 47. Scrolling in the logbook is possible using commands 881 to 883: → Command lists (Page 141). Legal-for-trade reading of the logbook is carried out using the SecureDisplay.

Table 8-26 Assignment of data record 47

Variable	Note	Type	Length (bytes)	Rw	Default	Min.	Max.	Modbus registers
Data record number	Contains no. of data record	USHORT	2	r	46			6900
Length	Data record length information	USHORT	2	r	128			6901
Application	Information about which application the data record belongs to	USHORT	2	r	101			3902
Version identifier	Information about current data record version	USHORT	2	r	1	1	65635	6903
String header for ID of oldest logbook entry	String header	UBYTE[2]	2	r	8.8			6904
ID of oldest logbook entry	ID of first logbook entry	CHAR[8]	8	r	" 0"	1	99999999	6905
String header for ID of most recent logbook entry	String header	UBYTE[2]	2	r	8.8			6909
ID of most recent logbook entry	ID of last logbook entry	CHAR[8]	8	r	" 0"	1	99999999	6910
String header for selected logbook entry	String header	UBYTE[2]	2	r	8.8			6914
ID of selected logbook entry	ID of selected logbook entry	CHAR[8]	8	r	" 0"	1	99999999	6915
String header for logbook event	String header	UBYTE[2]	2	r	4.4			6919
Logbook event	Currently only logbook for Secure-Display SW changes, corresponds to entry "HMI"	CHAR[4]	4	r	" "			6920
String header for old SW version	String header	UBYTE[2]	2	r	10.10			6922
Old SW version	Old FW version, e.g. V1.01.03	CHAR[10]	10	r	" "			6923
String header for new SW version	String header	UBYTE[2]	2	r	10.10			6928
New SW version	New FW version, e.g. V1.01.04	CHAR[10]	10	r	" "			6929
CRC16	Checksum of logbook entry	USHORT	2	r	0			6934
Reserve	Reserve	USHORT	2	r	0			6935

8.27 DR 48 date and time 2 (for Modbus)

The SIWAREX module has its own hardware clock. The current date and the time can be set and read using data record DR 48. The clock is buffered with a capacitor and can continue operating for up to approximately 70 hours without supply voltage. If you are not using the Modbus protocol, data record DR 8 is used for the date and time.

Procedure

- Set the date and time
- Transfer the data record to the SIWAREX module

Table 8-27 Assignment of data record 48

Variable	Note	Type	Length (bytes)	Rw	Default	Min.	Max.	Modbus registers
Data record number	Contains no. of the data record	USHORT	2	r	48	-	-	6960
Length	Data record length information	USHORT	2	r	24	-	-	6961
Application	Information on which application the data record belongs to	USHORT	2	r	101	-	-	6962
Version identifier	Information on the current data record version	USHORT	2	r	1	1	65635	6963
Year	Year	USHORT	2	rw	2012	2012	2010	6964
Month	Month	USHORT	2	rw	1	1	12	6965
Day	Day in month	USHORT	2	rw	1	1	31	6966
Hour	Hour	USHORT	2	rw	0	0	23	6967
Minute	Minute	USHORT	2	rw	0	0	59	6968
Second	Second	USHORT	2	rw	0	0	59	6969
Millisecond	Millisecond	USHORT	2	rw	0	0	999	6970
Day of the week	Day of the week	USHORT	2	rw	1	1	7	6971

8.28 DR 59 Parameter string digital load cell

When using a digital load cell of the Wipotec company, the parameters and commands are sent to the cell using the string in DS59. The "Display duration" parameter defines how long the responses of the load cell are displayed in DS34.

The parameter string is transferred once when establishing the communication to the load cell (command 905). The command syntax is identical to the syntax of WIN Term.

Example: The average value filter in the load cell is to be set to 10 and stored.

- Display duration: 2000 ms
- Parameter string: R10;S;

8.29 DR 70 SIWAREX DB parameter

After establishing the communication (command 905), the average value filter is set to 10 and stored. The responses of the cell are shown for 2000 ms in DS34. Then the weight value is displayed.

Table 8-28 Assignment of data record 59

Variable	Note	Type	Length (bytes)	RW	Default	Min.	Max.	Modbus registers
Data record number	Contains no. of data record	USHORT	2	r	59	-	-	7100
Length	Data record length information	USHORT	2	r	28	-	-	7101
Application	Information about which application the DR belongs to	USHORT	2	r	101	-	-	7102
Version identifier	Information on the current data record version	USHORT	2	r	1	1	65635	7103
Display duration	String header Parameter string	USHORT	2	rw	2000	-	-	7104
String header Parameter string	String header Parameter string	UBYTE[2]	2	rw	16,16	-	-	7105
Parameter string	Parameter string	CHAR[16]	16	rw	16,16	-	-	7106

8.29 DR 70 SIWAREX DB parameter

The parameters which define the response in combination with SIWAREX DB are specified in data record DR 70.

If SIWAREX DB is not used, the default settings can be accepted.

Table 8-29 Assignment of data record DR 70

Variable	Note	Data type	Length (bytes)	Rw	Default	Min.	Max.	Modbus registers
Data record number [DR_NO]	Contains no. of data record	USHORT	2	R	70	-	-	7200
Length [DR_LEN]	Data record length information	USHORT	2	R	180	-	-	7201
Application [APPL_ID]	Information on which application the data record belongs to	USHORT	2	R	101	-	-	7202
Version identifier [DR_VERSION]	Information on the current data record version	USHORT	2	r	1	1	65635	7203
Load cell manufacturer [LOAD_CELL_MANUFACTURER]	Load cell manufacturer	CHAR[24]	24	r/w	„ „	-	-	7205

Variable	Note	Data type	Length (bytes)	Rw	Default	Min.	Max.	Modbus registers
Load cell order number [LOAD_CELL_ORDER_NUMBER]	Load cell order number	CHAR[24]	24	r/w	„ „	-	-	7218
Load cell input 1: Location designation of sensor [LOAD_CELL_INPUT_1_LOCATION_TAG]	Location designation of sensor	CHAR[24]	24	r/w	„ „	-	-	7231
Load cell input 2: Location designation of sensor		CHAR[24]	24	r/w	„ „	-	-	7244
Load cell input 3: Location designation of sensor		CHAR[24]	24	r/w	„ „	-	-	7257
Load cell input 4: Location designation of sensor		CHAR[24]	24	r/w	„ „	-	-	7270
Channel active [LOAD_CELL_ENABLE]	Bit 0: Load cell input 1 [INPUT_1] Bit 1: Load cell input 2 [INPUT_2] Bit 2: Load cell input 3 [INPUT_3] Bit 3: Load cell input 4 [INPUT_4]	USHORT	2	r/w	15	0	15	7282
Sensor type [SENSOR_TYPE]	0: 4-wire sensor 1: 6-wire sensor	USHORT	2	r/w	0	0	1	7283
Total capacity of all load cells [NOMINAL_LOAD]	Total capacity of all load cells	FLOAT	4	r/w	1000	tbd	tbd	7284

8.30 DR 80 SIWAREX DB process status

In data record DR 81, monitor the current statuses and process values in the scales with the help of the SIWAREX DB. To optimize the parameters, monitor selected data when commissioning the scales.

It is not always necessary to cyclically read data record DR 80. Messages and status bits are automatically read out by the function block when a change occurs.

Table 8-30 Assignment of data record DR 80

Variable	Note	Type	Length (bytes)	Rw	Default	Min.	Max.	Modbus registers
Data record number [DR_NO]	Contains no. of data record	USHORT	2	R	80	-	-	7300
Length [DR_LEN]	Data record length information	USHORT	2	R	76	-	-	7301
Application [APPL_ID]	Information on which application the data record belongs to	USHORT	2	R	101	-	-	7302

8.30 DR 80 SIWAREX DB process status

Variable	Note	Type	Length (bytes)	Rw	Default	Min.	Max.	Modbus registers
Version identifier [DR_VERSION]	Information on the current data record version	USH-ORT	2	r	1	1	65635	7303
Refresh counter [REFRESH_COUNTER]	Cycle counter of the SIWAREX DB incremented by 1 if process values have been changed.	USH-ORT	2	r	0	0	0xFFFF	7304
Device status [MODULE_ERROR_INFORMATION]	Bit 0: QI flag Bit 1: Load cell input faulty Bit 2: Checksum error Bit 3: Checksum error (data) Bit 4: Watchdog error Bit 5: ADC error Bit 6: Temperature warning Bit 7: Firmware update error	USH-ORT	2	r	0	-	-	7305
Load cell input 1: Status [LOAD_CELL_INPUT_1_DIAGNOSTIC_INFORMATION]	Bit 0: QI flag Bit 1: Underload Bit 2: Overload Bit 3: SEN error Bit 4: Impedance error Bit 5: EXC short circuit Bit 6: Power supply failure	USH-ORT	2	r	0	-	-	7307
Load cell input 1: filtered digit value [LOAD_CELL_INPUT_1_DIGITS_FILTERED]	Filtered digit value of AD converter from SIWAREX DB to dig. filter 1	LONG	4	r	0x7FFF FFFF	0x8000 0000	0x7FFF FFFE	7308
Load cell input 1: Load (%) [LOAD_CELL_INPUT_1_PERCENTAGE_LOAD]	Current percentual load of the load cell in relation to the rated load of the load cell	FLOAT	4	r	0	-200	200	7310
Load cell input 1: Signal voltage SIG (mV) [LOAD_CELL_INPUT_1_LOAD_CELL_SIGNAL]	Currently measured load cell signal	Float	4	r	0	-200	200	7312

Variable	Note	Type	Length (bytes)	Rw	Default	Min.	Max.	Modbus registers
Load cell input 2: Status	Bit 0: QI flag Bit 1: Underload Bit 2: Overload Bit 3: SEN error Bit 4: Impedance error Bit 5: EXC short circuit Bit 6: Power supply failure	USH-ORT	2	r	0	-	-	7315
Load cell input 2: Filtered digit value	Filtered digit value of AD converter from SIWAREX DB to dig. filter 1	LONG	4	r	0x7FFF FFFF	0x8000 0000	0x7FFF FFFE	7316
Load cell input 2: Load (%)	Current percentual load of the load cell in relation to the rated load of the load cell	FLOAT	4	r	0	-200	200	7318
Load cell input 2: Signal voltage SIG (mV)	Currently measured load cell signal	Float	4	r	0	-200	200	7320
Load cell input 3: Status	Bit 0: QI flag Bit 1: Underload Bit 2: Overload Bit 3: SEN error Bit 4: Impedance error Bit 5: EXC short circuit Bit 6: Power supply failure	USH-ORT	2	r	0	-	-	7323
Load cell input 3: filtered digit value [LOAD_CELL_INPUT_3_DIGITS_FILTERED]	Filtered digit value of AD converter from SIWAREX DB to dig. filter 1	LONG	4	r	0x7FFF FFFF	0x8000 0000	0x7FFF FFFE	7324
Load cell input 3: Load (%)	Current percentual load of the load cell in relation to the rated load of the load cell	FLOAT	4	r	0	-200	200	7326
Load cell input 3: Signal voltage SIG (mV)	Currently measured load cell signal	Float	4	r	0	-200	200	7328
Load cell input 4: Status	Bit 0: QI flag Bit 1: Underload Bit 2: Overload Bit 3: SEN error Bit 4: Impedance error Bit 5: EXC short circuit Bit 6: Power supply failure	USH-ORT	2	r	0	-	-	7331

8.31 DR 81 SIWAREX DB process status advanced

Variable	Note	Type	Length (bytes)	Rw	Default	Min.	Max.	Modbus registers
Load cell input 4: Filtered digit value	Filtered digit value of AD converter from SIWAREX DB to dig. filter 1	LONG	4	r	0x7FFF FFFF	0x8000 0000	0x7FFF FFFE	7332
Load cell input 4: Load (%)	Current percentual load of the load cell in relation to the rated load of the load cell	FLOAT	4	r	0	-200	200	7334
Load cell input 4: Signal voltage SIG (mV)	Currently measured load cell signal	Float	4	r	0	-200	200	7336

8.31 DR 81 SIWAREX DB process status advanced

Current states and process values in the scales can be monitored using SIWAREX DB specific advanced process values and process values from data record DR 80.

Table 8-31 Assignment of data record DR 81

Variable	Note	Type	Length (bytes)	Rw	Default	Min.	Max.	Modbus registers
Data record number [DR_NO]	Contains no. of data record	USHORT	2	R	81	-	-	7338
Length [DR_LEN]	Data record length information	USHORT	2	R	64	-	-	7339
Application [APPL_ID]	Information on which application the data record belongs to	USHORT	2	R	101	-	-	7340
Version identifier [DR_VERSION]	Information on the current data record version	USHORT	2	r	1	1	65635	7341
Excitation voltage EXC (V) [EXCITATION_VOLTAGE]	Excitation voltage EXC (V) with which the load cells are supplied	FLOAT	4	r	0	0	10000	7342
Load cell input 1: Impedance (Ohm) [LOAD_CELL_INPUT_1_IMPEDANCE]	Current impedance (Ohm) of connected load cell	FLOAT	4	r	0	0	20000	7344
Load cell input 2: Impedance (Ohm)		FLOAT	4	r	0	0	20000	7346
Load cell input 3: Impedance (Ohm)		FLOAT	4	r	0	0	20000	7348
Load cell input 4: Impedance (Ohm)		FLOAT	4	r	0	0	20000	7350

Variable	Note	Type	Length (bytes)	Rw	Default	Min.	Max.	Modbus registers
Load cell input 1: Sense voltage SEN (V) [LOAD_CELL_INPUT_1_SENSE_VOLTAGE]	Current voltage (V) which is measured between SENSE+ and SENSE- of the load cell	FLOAT	4	r	0	0	10000	7352
Load cell input 2: Sense voltage SEN (V)		FLOAT	4	r	0	0	10000	7354
Load cell input 3: Sense voltage SEN (V)		FLOAT	4	r	0	0	10000	7356
Load cell input 4: Sense voltage SEN (V)		FLOAT	4	r	0	0	10000	7358
Load cell input 1: Excitation current (mA) [LOAD_CELL_INPUT_1_EXCITATION_CURRENT]	Current excitation current (mA) which is required for the supply of the load cell	FLOAT	4	r	0	0	1999	7360
Load cell input 2: Excitation current (mA)		FLOAT	4	r	0	0	1999	7362
Load cell input 3: Excitation current (mA)		FLOAT	4	r	0	0	1999	7364
Load cell input 4: Excitation current (mA)		FLOAT	4	r	0	0	1999	7366
Temperature (°C) [TEMPERATURE]	Current temperature (°C) of the SIWAREX DB electronic system	FLOAT	4	r	0.0	-50	+150.0	7368

8.32 DR 82 SIWAREX DB device information

You cannot make any entries in data record DR 82. This data record only provides information on the inner workings of the SIWAREX DB. This information is used to identify SIWAREX DB at the manufacturer plant. The entries in the data record are of no importance to the user for operation.

Table 8-32 Assignment of data record DR 82

Variable	Note	Type	Length (bytes)	Rw	Default	Min.	Max.	Modbus registers
Data record number [DR_NO]	Contains no. of data record	USHORT	2	R	82	-	-	7370
Length [DR_LEN]	Data record length information	USHORT	2	R	184	-	-	7371
Application [APPL_ID]	Information on which application the data record belongs to	USHORT	2	R	101	-	-	7372
Version identifier [DR_VERSION]	Information on the current data record version	USHORT	2	r	1	1	65635	7373

8.32 DR 82 SIWAREX DB device information

Variable	Note	Type	Length (bytes)	Rw	Default	Min.	Max.	Modbus registers
Order number [ORDER_NO]	Order number SIWAREX DB	CHAR[32]	32	r	” ”	-	-	7375
Serial number [SERIAL_NO]	Serial number SIWAREX DB	CHAR[32]	32	r	” ”	-	-	7426
FW version number [FW_VERSION]	FW version number SIWAREX DB	CHAR[16]	16	r	” ”	-	-	7443
HW version [HW_VERSION]	HW version SIWAREX DB	CHAR[16]	16	r	” ”	-	-	7452
Hardware device ID [HW_DEVICE_ID]	Hardware device ID SIWAREX DB	USHORT	2	r	0	0	31	7460

Messages

9.1 Message types

The messages in the electronic weighing system described here are divided into three types.

System status messages

System status messages can be generated spontaneously at any time by an unexpected event. They include internal and external hardware problems which can occur spontaneously during weighing.

Data and operating errors

The data and operating errors are always a response to a command due to a plausibility check.

These are data errors if a plausibility error has been detected in a data packet which was sent to the module and receipt of the packet has been rejected by the module.

These are operating errors if the module cannot execute the sent command in its current operating state.

Technology errors

Technology errors occur spontaneously due to the process flow of a weighing.

Status bits, on the other hand, are not messages. The status displays describe the status of the scale during normal operation and can be monitored or evaluated at any time.

9.2 Message paths

You can read out the messages using different paths. You define the path for forwarding and processing of messages during configuration.

The messages are processed for two basic purposes:

- For display on an Operator Panel for the operator
- For linking in the control software to control specific reactions in the process.

The following message paths are possible:

- Output of the message buffer to the SIWATOOL program (takes place automatically)
- Output by means of function block as bit field in Scale data block
- Output by means of data records DR 30 and DR 32 in case of communication with a Modbus master

9.3 Evaluating messages with the help of SIWATOOL

The electronic weighing system has a message buffer that can hold up to 80 entries. If the number of alarms in the alarm buffer exceeds 80, the oldest entry is overwritten. The message buffer can be read out at any time with the help of SIWATOOL (menu item "Receive all data") and saved together with the scale parameters. This facilitates the detection, analysis and correction of errors in the system.

SIWAREX DB

If you use SIWAREX DB, the type of error of the load cell input affected is reported in SIWATOOL via Supplementary info 1.

9.4 Evaluating messages with the help of the SIMATIC FB

All messages of the electronic weighing system can be completely detected and processed in the SIMATIC controller with the help of the SIWAREX WP231 function block (FB). The messages can be evaluated directly in a signaling system by means of a bit signaling area in the scale data block. The message texts are stored in the signaling system. If a bit assumes the value "1", a message text is output.

If a message occurs for SIWAREX data block, DR 80 is automatically read; it contains the corresponding message bits.

9.5 Message list

The message list is an overview of all messages that the SIWAREX module can generate. A message can be quickly identified by the message code (number).

9.5.1 System status message list

Operating errors (code 1000 to 1999) sorted by code no.	Error code	Description and remedy
1000 Operational error exists	1000	Group message, at least one operating error exists.
1001 Watchdog	1001	Watchdog, error is displayed for at least 10 seconds. A serious error has occurred in the function of the electronic weighing system, e.g. program error, severe electromagnetic influence on device, etc. Contact SIWAREX Support if the error occurs multiple times.
1002 RAM error	1002	RAM error. An error has occurred in the memory; the memory content is no longer correct. The electronic weighing system must be switched off. If the error occurs again, the electronic weighing system is defective.
1003 Checksum incorrect parameter	1003	Checksum error at parameter. Critical error because the parameters are no longer safe.
1004 Checksum incorrect program	1004	Checksum error program code. Critical error because the program is no longer safe.

Operating errors (code 1000 to 1999) sorted by code no.	Error code	Description and remedy
1006 logbook error	1006	Error when writing/deleting, or logbook full
1102 ADU error	1102	AD converter error when reading in the measured value. If the error occurs again, make sure that the EMC recommendations are observed (chapter EMC-compliant setup (Page 26)).
1104 Undervoltage	1104	Undervoltage at sensor cables
1105 Overload	1105	Overload of scale (ca. 110%)
1106 Underload	1106	Underload of scale (ca. -10%)
1107 Legal trade main display failure	1107	The calibratable display no longer communicates with the electronic weighing system
1110 SIWAREX DB or digital load cell not ready	1110	No communication with SIWAREX DB or digital load cell

9.5.2 Technology error message list

Technology error (code 2000 to 4999)	Error code	Description and remedy
2000 Technology error exists	2000	Group message, at least one technology error exists
2001 Timeout tare/set to zero	2001	Taring of scale or set to zero is not possible because a standstill was not reached during the standstill time. The command was discarded.
2002 Trace overload	2002	The set recording rate for trace function cannot be processed. Set a slower recording rate (chapter "Trace recording cycle (Page 95)")
2003 Set to zero not possible	2003	The switch-on weight is outside the configured value range for set to zero in data record DR 3 defined by the maximum positive and negative weight.

9.5.3 Data and operating errors message list

Data and command errors (code 5000 to 8999)	Error code	Description and remedy
5000 Data or comand error exists	5000	Group error, a bit is set in the data and operating error bits.
5001 Data record or comand unknown	5001	Command code or data record is not known with current application.
5002 Command or data change not possible because write protection is active	5002	The command or changing of data is not possible due to write protection. The data record was rejected.
5003 Cannot exit service mode	5003	Cannot exit calibration mode; calibration incomplete.
5004 Command or data transfer only permitted in service mode	5004	Activation of service mode is required to execute command or transmit data.
5006 Command or data transfer not possible while BUSY	5006	Command can currently not be executed because module is BUSY (data record or command transmission already active, ...).





9.5 Message list

Data and command errors (code 5000 to 8999)	Error code	Description and remedy
5007 Command or data transmission not possible because module is faulty or SIMATIC CPU stop	5007	Command can currently not be executed because of a problem or SIMATIC CPU stop.
5102 Comand not possible while not standstill	5102	Scale command (set to zero, tare, log, ...) cannot be executed because standstill is missing.
5103 Command not possible because legal trade display is missing	5103	Command not possible because legal trade display is missing or not visible.
5104 Command not possible while limit exceeded	5104	Command (e.g. set to zero, tare, calibrate command) cannot be executed because the permitted range has been exceeded. The ranges are defined in DR 3.
5105 Load cell parameters not plausible	5105	Load cell parameters in data record DR 10 are not plausible (number, support points, load specifications, etc.).
5107 Calibration characteristic shift not possible	5107	Characteristic cannot be moved due to possibility of range violation.
5108 ID does not exist	5108	Requested logbook ID not present in memory.
5109 Logging not possible because weight has not changed since last logging	5109	Standstill must be lost at least once after logging before new logging is possible.
5199 Error in command to DI	5199	Processing of a command triggered at the DIs is not possible. The cause can be determined in data record DR 32.
6002 Logging not possible because weight is too small	6002	Logging is not possible because the limits for the minimum weight or maximum weight were not observed.
7000 Permitted number range violated	7000	The permitted number range, such as for weight values, was violated.
7001 Restriction code unknown	7001	Regulation code for application requiring official calibration not known.
7002 Length of ASCII string not plausible	7002	The string header in a specified string variable is not plausible.
7003 Date / Time parameter not plausible	7003	Specifications for date and time are not plausible.
7004 Assignment of digital input or output incorrect	7004	An error occurred while assigning the digital inputs or digital outputs.
7006 Reserved	7006	Reserved
7007 Calibration weights / Calibration digits not plausible	7007	Specifications for calibration weights or digits in data record DR 3 are incorrect (minimum distance, reversal of incline).
7008 Zero- / Tare values not plausible	7008	The specifications for set to zero (data record DR 3) or tare specifications (data record DR 15) are not plausible.
7009 Standstill range / standstill wait time	7009	Standstill range or standstill wait time are not plausible.
7010 Scale interval / rounding	7010	Resolution or selection for rounding to decimal places is not plausible.
7011 Filter parameters	7011	Specification of filter parameters is not plausible.
7013 Interface assignment for legal-for-trade HMI not plausible	7013	The assignment of the interface to the legal-for-trade HMI is incorrect.
7014 Time parameter not plausible	7014	Specified time value is not plausible or may be signaled in connection with additional errors.
7016 Analog output parameter not plausible	7016	The parameters for the analog output (data record DR 7) are not plausible.
7017 MAC address cannot be changed	7017	

Data and command errors (code 5000 to 8999)	Error code	Description and remedy
7018 Error in IP mask	7018	The specified IP addresses (DR12) are not plausible.
7019 RS485 parameter error	7019	The specified RS485 interface parameters (DR13) are not plausible.

9.5.4 Messages by LEDs on the module

The LEDs on the front of the SIWAREX module signal the following status and error messages.

Item	Color	Labeling	Function
Line 1			
LED 0	Red	DIAG	System fault
	Green		Ready
	Green flashing		Service mode is switched on
LED 1	Yellow		Limit 1 activated
LED 2	Yellow		Limit 2 activated
LED 3	Yellow		Limit 3 responded (empty limit)
LED 4	Green		Standstill status
LED 5	Green	-0-	¼ d zero status
LED 6	Red	Max	Max. violated (with NAW Max+9e)
LED 7	Yellow		Parameter input blocked (write protection)
LED 8			Not used
LED 9	Green	LC	Load cell(s) OK
	Red		Load cell(s) faulty
LED 10			Not used
LED 11			Not used
LED 12			Not used
LED 13			Not used
LED 14			Not used
LED 15			Not used
LED 16	Green	AQ	Analog output active
	Red		Analog output error
Line 2			
LED 1	Green	LINK	LAN connection exists
LED 2	Yellow	Rx/Tx	LAN communication active
LED 3			Not used

9.5 Message list

Item	Color	Labeling	Function
LED 4			Not used
LED 5	Green	DI.0	Digital input 0 active
LED 6	Green	DI.1	Digital input 1 active
LED 7	Green	DI.2	Digital input 2 active
LED 8	Green	DI.3	Digital input 3 active
LED 9			Not used
LED 10			Not used
LED 11	Yellow	Rx/Tx	RS485 communication active
LED 12			Not used
LED 13	Green	DQ.0	Digital output 0 active
LED 14	Green	DQ.1	Digital output 1 active
LED 15	Green	DQ.2	Digital output 2 active
LED 16	Green	DQ.3	Digital output 3 active

Command lists

10.1 Overview

The commands for the electronic weighing system described here can be transmitted by several interfaces:

- by the Operator Panel via the controller to the SIWAREX module
- by the Operator Panel directly to the SIWAREX module
- by SIWATOOL directly to the SIWAREX module
- by the digital inputs after corresponding assignment in data record DR 7

A data or command error is signaled if a command cannot be executed or if the sent data record is rejected.

Detailed descriptions of the commands can be found in the following command lists:

- Table 10-1 Commands 1 ... 99: Service commands (Page 142)
- Table 10-2 Commands 400 ... 449; log commands, statistics, logbook (Page 143)
- Table 10-3 Commands 450 ... 499: Trace commands (Page 143)
- Table 10-4 Commands 700 to 899: HMI display switching (Page 144)
- Table 10-5 Commands 1000 ... : Basic functions for weighing commands (Page 145)
- Command groups of the electronic weighing system (Page 146)

See also

Command lists (Page 141)

10.2 Command lists

The commands for the electronic weighing system described here can be transmitted by several interfaces:

- From the operator panel via the controller to the SIWAREX module
- From the operator panel directly to the SIWAREX module
- From SIWATOOL direct to the SIWAREX module
- Via the digital inputs after corresponding assignment in data record DR 7

A data or command error is signaled if a command cannot be executed or if the sent data record is rejected.

Table 10-1 Commands 1 ... 99: Service commands

Command code	Command	Description	Protected
1	Service mode On	Turn on service mode	
2	Service mode Off	Turn off service mode	
3	Test mode On (simulation)	Turn on test mode. The simulation value from data record 16 is used instead of the measured value for calculation of the process values.	
4	Test mode Off (simulation)	Switch off test mode.	
11	Load factory setting	The command resets the SIWAREX to the "ex works" status. During this process: <ul style="list-style-type: none"> • All parameters and saved data (including protocol memory and logbook) as well as the restore point are loaded with the default values • All message buffers (diagnostic buffer, trace memory, etc.) are reset 	P
12	Load standard parameters	Like "Load factory settings" (command code 11), but interface settings for Ethernet and Modbus RTU are not reset to the factory setting.	P
31	Load restore point	All parameters saved in the restore point are activated.	P
51	Create restore point	Saves the parameters of the restore point to the memory.	P
60	Set Calibration Point 0	Set Calibration Point 0 / save values for calibration point 0.	P
61	Set Calibration Point 1	Set Calibration Point 1 / save values for calibration point 1.	P
62	Set Calibration Point 2	Set Calibration Point 2 / save values for calibration point 2.	P
81	Characteristic shift	Move calibration characteristic. The command defines the current weight of the scale as the new zero point (0 kg) and shifts the complete characteristic without changing the gradient. The command can be used, for example, in order to compensate parts used for mounting calibration weights on the scale at the end of the calibration.	P
82	Perform automatic calibration	Calculating the scale characteristic curve with reference to the load cell from data record 10. The calculated characteristic curve is entered directly in data record 3 and 4, and thus activated immediately after executing the command. The scale must be empty when the command is executed.	P

Command code	Command	Description	Protected
83	Perform calibration check	The command calculates the theoretical digital values in relation to the calibration weights using the load cell parameters from data record 10 and the adjustment weights 0, 1 and 2 from data record 3. The output of these theoretical digits is made in data record 4. The function can be used to check the plausibility of adjustment digits in data record 3, which have been determined in a legal-for-trade calibration.	
905	Start communication with digital load cell	When using a digital load cell (Wipotec or Mettler-Toledo), initialize or start the communication between SIWAREX WP231 and the load cell once using the 905 command. The command is stored retentively. When changing the interface parameters (baud rate, parity, etc.), stop the communication and restart it. The "Digital load cell ready" status bit in DS30 provides information on whether or not communication is taking place.	
906	Stop communication with digital load cell	When using a digital load cell (Wipotec or Mettler-Toledo), you can stop the communication between SIWAREX WP231 and the load cell once using the 906 command. This is required, for example, when replacing the load cell. When communication has stopped, the "Digital load cell ready" bit in DS30 is set to FALSE and WP231 indicates a fault.	

Table 10-2 Commands 400 ... 449; **log commands, statistics, logbook**

Command code	Command	Description	Protected
401	Generate log	Log current parameters relevant to the calibration	
405	Delete log memory	Delete all logs	P
440		Delete the logbook. Only permitted in non-calibrated state.	
441	Reserve		

Table 10-3 Commands 450 ... 499: Trace commands

Command code	Command	Description	Protected
451	Trace RAM on	Start permanent tracing	
452	Trace RAM off	Stop permanent tracing	
453	Single trace RAM	Create single trace (current state)	
454	Delete trace RAM	Delete tracing memory.	

Table 10-4 Commands 700 to 899: HMI display switching

Command code	Command	Description	Protected
701	Increased resolution	Enable increased resolution on the main display and the SecureDisplay (x 10), for duration of 5 s	
705	Display current tare weight	Display current tare weight on main display and SecureDisplay	
710	Activate standard display	Enable the standard display for gross/net (main display and SecureDisplay)	
714	N process value (no write protection)	Display the net process weight on the main display, only permitted if OIML is not set as the restriction code (main display and SecureDisplay)	P
715	G process value (no write protection)	Display gross process weight on main display, only permitted if OIML R76 is not set as the regulation code (main display and SecureDisplay)	P
716	G process value after filter 2	Display gross process weight (commissioning) on main display, only permitted if OIML R76 is not set as the regulation code (main display and SecureDisplay)	P
801	Display currently set calibration regulation /country code	Display currently set calibration regulation temporarily on the main display (main display and SecureDisplay), for duration of 5 s	
802	Display weighing range data	Display weighing range data (min., max., digit step) in the legal trade display SecureDisplay (for duration of 10 s)	
860	Hide display	Hides the legal trade display SecureDisplay	
861	Legal trade display for variant 1	Acts on the legal trade display SecureDisplay. Enables version 1 for display size and position according to DisplayCali.xml file	
862	Legal trade display for variant 2	Acts on the legal trade display SecureDisplay. Enables version 1 for display size and position according to DisplayCali.xml file	
863	Legal trade display for variant 3	Acts on the legal trade display SecureDisplay. Enables version 1 for display size and position according to DisplayCali.xml file	
864	Legal trade display for variant 4	Acts on the legal trade display SecureDisplay. Enables version 1 for display size and position according to DisplayCali.xml file	
865	Legal trade display for variant 5	Acts on the legal trade display SecureDisplay. Enables version 1 for display size and position according to DisplayCali.xml file	
870	Display smallest representation of legal trade display	Shows the smallest possible display of the SecureDisplay according to parameter "Min. zoom factor Display%" in DR3	
871	Display current serial number	Display serial number of SIWAREX temporarily on the main display and in SecureDisplay for a duration of 5 s	

Command code	Command	Description	Protected
875	Display FW version	Display current firmware version of module on SecureDisplay	
876	Display SecureDisplay software version		
881	Display first logbook entry	The first logbook entry is displayed on the SecureDisplay.	
882	Display last logbook entry	The last logbook entry is displayed on the SecureDisplay.	
883	Display reading of previous entry	The logbook entry prior to the last read entry is displayed on the SecureDisplay.	
884	Display reading of subsequent entry	The logbook entry after the last read entry is displayed on the SecureDisplay.	
891	Display log entry (DS46)	The log entry requested in DS45 is displayed on the SecureDisplay, for duration of 10 s.	
Reserve			
Reserve			
Reserve			

Table 10-5 Commands 1000 ... : Basic functions for weighing commands

Command code	Command	Description	Protected
1001	Set to zero	Zeroing (semi-automatic)	
1011	Tare	Taring (semi-automatic)	
1012	Delete tare	Delete current tare weight	
1013	Tare specification 1 valid	Activate specification tare weight 1	
1014	Tare specification 2 valid	Activate specification tare weight 2	
1015	Tare specification 3 valid	Activate specification tare weight 3	
1016	SIMATIC tare specification	Specified tare weight from SIMATIC I/O interface	

See also

Integration in SIMATIC S7-1200 (Page 147)

10.3 Command groups of the electronic weighing system

The following commands can be triggered in the scale data block DB_SCALE in the area CMD1 to CMD3:

Command code	Description
1 ... 1999	The meanings of the commands correspond to the command list (see → Command lists (Page 141)).
2000 + X	Reading a data record from the electronic weighing system X = Data record number Example: Data record 3 transmitted by the electronic weighing system to the SIMATIC controller → 2000 + 3 = command code 2003
4000 + X	Writing of record to the electronic weighing system X = Data record number Example: Data record 3 transmitted by the SIMATIC controller to the electronic weighing system → 4000 + 3 = command code 4003
7001	Read all data. Read all data from the electronic weighing system to the SIMATIC controller
7002	Write all data. Write all data from the SIMATIC controller to the electronic weighing system (service mode has to be turned on)

Additional information on transmission of commands from the control program by means of the SIMATIC interface is available in chapter Integration in SIMATIC S7-1200 (Page 147).

Communication

11.1 Integration in SIMATIC S7-1200

11.1.1 General information

A SIWAREX WP231 occupies 32 bytes each in the I/O areas of the CPU. The maximum number of SIWAREX WP231 weighing modules is defined as follows:

S7-1212 CPU → up to two WP231 weighing modules

S7-1214 CPU → up to eight WP231 weighing modules

S7-1215 CPU → up to eight WP231 weighing modules

S7-1217 CPU → up to eight WP231 weighing modules

Additionally observe the memory requirements for the respective function block calls.

Two types of function block are available: with integrated data record communication (DS communication) or without data record communication. The difference is that data record communication permits full access to all parameters (e.g. calibration weights, filters, limits) of the scale from the S7-1200 CPU and thus from the Touch panel (WP231 firmware 1.0.4 and higher).

Using the alternative function blocks without data record communication, the current process values of the scale (weight, status) can be read, and commands (taring, zeroing, etc.) can be sent. Complete commissioning from the CPU or HMI is not possible since the required parameters such as the calibration weight cannot be sent. This must be carried out on site using SIWATOOL.

Table 11-1 Memory requirements of the function block

	FB with DS communication (FB231 "WP231PR")	FB without DS communication (FB231 "WP231PE")
Read weight and status	YES	YES
Send commands	YES	YES
Send parameters	YES	NO
Main memory requirements in CPU	14 700 byte + n x 1 700 byte	7 800 byte + n x 400 byte
Load memory requirements in CPU	181 100 byte + n x 40 200 byte	59 000 byte + n x 19 500 byte

n = number of WP231 modules

The function blocks described above including HMI configuring can be downloaded as a predefined example project ("Ready-for-use") at: Example project "Ready-for-use" (<http://support.automation.siemens.com/WW/view/de/66825585>)

The most recent firmware version for the weighing module can be downloaded at: Firmware (<http://support.automation.siemens.com/WW/view/de/75231231>)

11.1.2 Operation on S7-1200 failsafe controllers

As of firmware V3.1.0, operation on SIMATIC S7-1200 failsafe controllers is possible.

11.1.3 Creating the hardware configuration

Starting with TIA Portal V12, the SIWAREX WP231 is integrated as standard in the hardware profile as an S7-1200 technology module.

For TIA Portal V11, an HSP is available for integration at: Hardware Support Package (<http://support.automation.siemens.com/WW/view/de/73514020>)

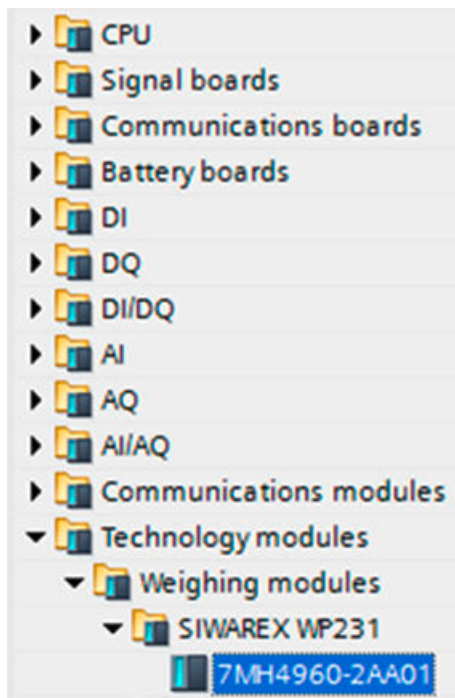

Figure 11-1 Configuration in the TIA Portal "HW catalog"

The module can be positioned directly next to the S7-1200 CPU using drag and drop.

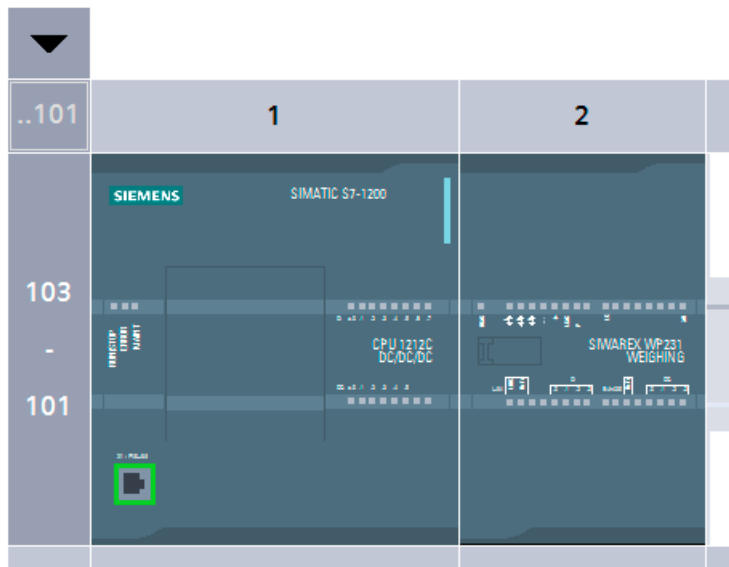

Figure 11-2 Configuration with S7-1212 CPU

TIA Portal automatically assigns a separate I/O start address and a HW ID for every SIWAREX present in the project. These two parameters are relevant for calling the function block, and can be obtained from the properties of the respective module.

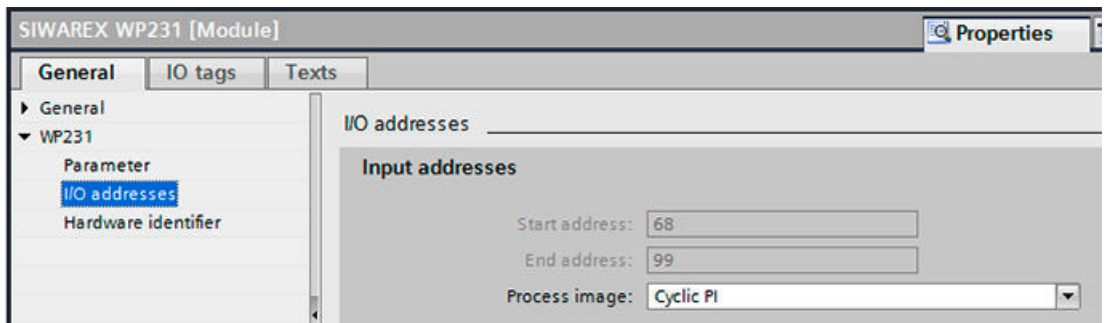

Figure 11-3 Start address of module in TIA Portal

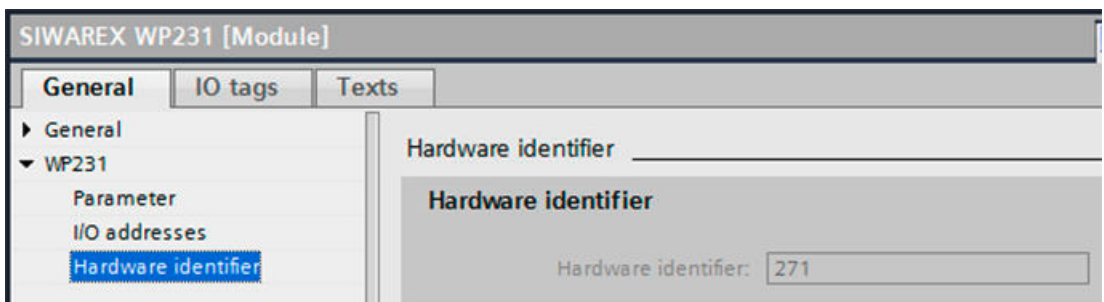

Figure 11-4 HW ID of module in TIA Portal

Diagnostic interrupts can be optionally enabled or deactivated in the module properties.

11.1.4 Calling of function block

This description is based on use of the WP231PR block with data record communication and the following data:

- **Start address** SIWAREX WP231: 68 (see → Creating the hardware configuration (Page 148))
- **HW ID** SIWAREX WP231: 271 (see → Creating the hardware configuration (Page 148))
- **Instance data block number** of SIWAREX WP231 function block: DB231

The function block can be integrated at the desired position in the user program using drag and drop. Calling of the FB must be carried out cyclically in the control program.

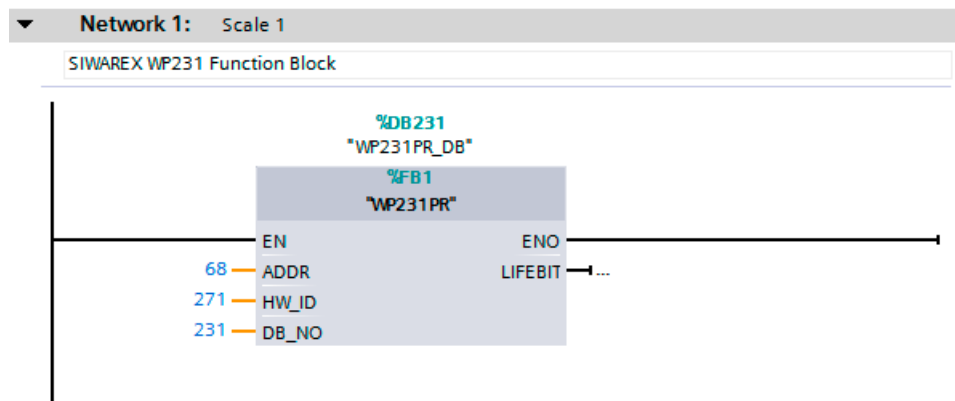

Figure 11-5 Calling of WP231PR block in user program

Function block parameter	Description
ADDR	Start address WP231 (see → Creating the hardware configuration (Page 148))
HW_ID	HW ID WP231 (see → Creating the hardware configuration (Page 148))
DB_NO	Number of FB-internal instance DB
LIFEBIT	Optional status bit can be used to monitor communication

The generated instance DB (DB231 in this case) contains all data records of the WP231 as well as all parameters required to exchange data between CPU and weighing module.

A separate FB call must be made in the user program for each weighing module. In this manner, each scale receives its own instance DB which provides the respective scale parameters. The input and output parameters of the FB must be matched to the respective WP231 for each call.

11.1.5 Working with the function block

Data records in SIWAREX weighing modules

All parameters in SIWAREX weighing modules are structured in data records. These data records must be considered as connected packages and can only be respectively read into the CPU or written to the SIWAREX as complete packages. Reading or writing of a single parameter within a data record is not possible. You can find a description of all data records and their parameters in chapter → Scale parameters and functions (Page 65).

Reading and writing of data records is performed using special command codes which can be sent with three command mailboxes handled according to priority within the instance DB:

11	[-] [0] [1] ▾ s_CMD1	Struct	456.0	
12	[-] [0] [1] ▣ i_CMD_CODE	Int	0.0	0
13	[-] [0] [1] ▣ bo_CMD_TRIGGER	Bool	2.0	false
14	[-] [0] [1] ▣ bo_CMD_InProgress	Bool	2.1	false
15	[-] [0] [1] ▣ bo_CMD_FinishedOK	Bool	2.2	false
16	[-] [0] [1] ▣ bo_CMD_FinishedError	Bool	2.3	false
17	[-] [0] [1] ▾ s_CMD2	Struct	460.0	
18	[-] [0] [1] ▣ i_CMD_CODE	Int	0.0	0
19	[-] [0] [1] ▣ bo_CMD_TRIGGER	Bool	2.0	false
20	[-] [0] [1] ▣ bo_CMD_InProgress	Bool	2.1	false
21	[-] [0] [1] ▣ bo_CMD_FinishedOK	Bool	2.2	false
22	[-] [0] [1] ▣ bo_CMD_FinishedError	Bool	2.3	false
23	[-] [0] [1] ▾ s_CMD3	Struct	464.0	
24	[-] [0] [1] ▣ i_CMD_CODE	Int	0.0	0
25	[-] [0] [1] ▣ bo_CMD_TRIGGER	Bool	2.0	false
26	[-] [0] [1] ▣ bo_CMD_InProgress	Bool	2.1	false
27	[-] [0] [1] ▣ bo_CMD_FinishedOK	Bool	2.2	false
28	[-] [0] [1] ▣ bo_CMD_FinishedError	Bool	2.3	false

Figure 11-6 CMD command mailboxes

As shown in the graphics, a command mailbox always consists of a command code (Int) and four bits (Bool). A command is set by entering the desired command code in the "i_CMD_CODE" parameter and setting the respective command trigger "bo_CMD_TRIGGER". The status bits "bo_CMD_InProgress" (command being processed), "bo_CMD_FinishedOk" (command finished without errors) and "bo_CMD_FinishedError" (command rejected or finished with error) can be evaluated in the user program.

In addition, the three command mailboxes are managed and processed according to priority. CMD1 has the highest priority, CMD3 has the lowest priority. If all three command mailboxes are triggered simultaneously by the user program, for example, the function block initially processes CMD1, then CMD2, and finally CMD3. Cyclic triggering of command mailbox 3 is also interrupted by intermediate sending of a command in mailbox 2 or 1 for processing of the respective command.

Note

Cyclic triggering of the CMD1 command mailbox makes it impossible to send commands in mailbox 2 or 3.

A summary of all existing command codes can be found in chapter → Command lists (Page 141).

The following equation for generation of a corresponding command code applies to the reading of data records from the SIWAREX to the data block:

$$\text{Command code} = 2000 + X \quad (\text{X} = \text{desired data record number})$$

The following equation for generation of a corresponding command code applies to the writing of data records from the data block to the SIWAREX:

$$\text{Command code} = 4000 + X \quad (\text{X} = \text{desired data record number})$$

Example

The following example clarifies the actions with command mailboxes and data records:

"Calibration weight 1" is to be set to a value of 12.5 by the CPU. Since "Calibration weight 1" is a parameter of data record 3 (see chapter → Scale parameters and functions (Page 65)), service mode must first be activated. This is possible using command code "1" (see chapter → Command lists (Page 141)).

The variable "i_CMD_CODE" must therefore be assigned the value "1" and the associated "bo_CMD_TRIGGER" set to TRUE. Subsequently, the module is directly in service mode (DIAG LED flashes green):

```
i_CMD_CODE = 1
```

```
bo_CMD_TRIGGER = TRUE
```

Since only complete data records can be read or written, it is recommendable to now read data record 3 into the CPU. This is carried out using command code 2003 (see chapter → Command lists (Page 141)):

```
i_CMD_CODE = 2003
```

```
bo_CMD_TRIGGER = TRUE
```

All current data from data record 3 are now present in the data block. The calibration weight is then set as desired to a value of 12.5:

```
CALIB_WEIGHT_1 = 12.5
```

The modified data record 3 must now be written into the SIWAREX again. This is carried out using command code 4003 (see chapter → Command lists (Page 141)):

```
i_CMD_CODE = 4003
```

```
bo_CMD_TRIGGER = TRUE
```

The new calibration weight is now present in the SIWAREX and can be used. Service mode for the module should subsequently be switched off again using command "2".

This procedure for reading and writing data records is identical for all data records.

11.1.6 I/O interface of function block

The following scale parameters are available cyclically in the data block in the controller without special reading of data records or can be sent to the scale without sending of data records:

Table 11-2 I/O data of function block

Parameter (read)	Meaning
SCALE_STATUS_1 (UINT)	Bytes 0 & 1 of the scale status (see data record 30)
SCALE_STATUS_2 (UINT)	Bytes 2 & 3 of the scale status (see data record 30)
PROCESS_VAL_1 (REAL)	Scale value in accordance with selection in data record 14
PROCESS_VAL_2 (REAL)	Scale value in accordance with selection in data record 14
OPERATION_ERRORS	Operating error according to Message list (Page 136)
TECHNOLOGICAL_ERRORS	Technological messages according to Message list (Page 136)
DATA_CMD_ERROR_1	Data/command error according to Message list (Page 136)
DATA_CMD_ERROR_2	Data/command error according to Message list (Page 136)
DATA_CMD_ERROR_3	Data/command error according to Message list (Page 136)
DATA_CMD_ERROR_4	Data/command error according to Message list (Page 136)
PROCESS_VAL_1 (DWORD)	Scale value in accordance with selection in data record 14
PROCESS_VAL_2 (DWORD)	Scale value in accordance with selection in data record 14
Parameter (write)	
TARE_VALUE (REAL)	Tare specification from S7 I/O (enabled by command 1016)
ANA_OUTPUT (REAL)	Specification for analog output if this has assigned "S7 interface" as the source in data record 7.
DIGIT_OUTPUT (UINT)	Specifications for digital outputs if these have been assigned as function "S7 interface" in data record 7.

11.1.7 Error codes of function block

Table 11-3 Statuses/errors when working with the function block

Error bit	Error description
bo_AppIIDError	Address module does not match the function block
bo_AppIIDDRError	Data record does not match the inserted module
bo_SFBEError	Runtime error during transmission of data record
bo_RdPerError	Reading of I/O data failed
bo_LifeBitError	SIWAREX no longer responds
bo_StartUpError	Command was sent although StartUp is still TRUE
bo_WrongFW	Data record version does not match the firmware
bo_InvalidCMD	An invalid command code was sent
bo_DataOperationError	Synchronous data operation error has occurred

Error bit	Error description
bo_StartUp	Startup synchronization of module running
bo_InvalidHW_ID	An invalid hardware ID was created at the function block call ("HW_ID" input).

Note

If execution of the function block is faulty, the variables shown do not correspond to the actual status in the module.

11.2 Communication via Modbus

11.2.1 General information

The current process values and parameters can be exchanged via the RS485 interface with Modbus RTU or the Ethernet interface with Modbus TCP/IP. It is possible to use both interfaces for the communication.

Note

The SIWAREX WP231 is designed for use in secure (closed) networks and does not have any protection against unauthorized data traffic.

The following chapters describe the specifications for handling communication. The following functions can be executed:

- Export parameters from the electronic weighing system
- Write parameters
- Export current process values
- Monitor messages

11.2.1.1 Principle of data transmission

This description is valid for communication via Modbus RTU and Modbus TCP/IP.

The standardized MODBUS protocol is used for communication. The master function is always in the connected communication partner, while the SIWAREX module is always the slave.

Data transfer is bidirectional. The master function is always in the connected module which “controls” the communication with corresponding requests to the respective SIWAREX module address. The SIWAREX module is always the slave and responds to the requests of the master, provided that the address matches, with a response frame.

Each Modbus partner has its own address. The SIWAREX module has the default address 1. This address can be changed as a parameter (e.g. in SIWATOOL). This address is without significance if the Ethernet interface is used because the connection is based on the IP address.

If the RS485 interface is used, the following character frame is valid:

Start bit	1
Number of data bits	8
Parity	Even
Stop bit	1

The following baud rates can be set:

- 9 600 bps
- 19 200 bps (default setting)
- 38 400 bps
- 57 600 bps
- 115 000 bps

Functions which can be used by the master are listed below. The structure and contents of the registers are shown in chapter "Scale parameters and functions (Page 65)".

Service	Function code	Usage
Read Holding Registers	03	Read one or more 16-bit parameter registers
Write Single Register	06	Write a single parameter register
Write Multiple Registers	16	Write multiple registers

If a request of the master is answered by the SIWAREX module (slave), the SIWAREX module sends a response frame with or without errors. In the case of a response without error message, the response frame contains the received function code; in the case of errors, the highest bit of the function code is set. This corresponds to the Modbus standard. Afterwards, the master requests the data record DR 32 to check which process-related data or command errors exist.

11.2.1.2 Data record concept

The register assignment is an image of the data records. The chapter → Scale parameters and functions (Page 65) describes the data records, variables and functions, including the register addresses. The data records are always checked as complete data packets for plausibility. For this reason, you must follow a specific procedure to change individual parameters.

11.2.1.3 Command mailboxes

Corresponding command codes must be sent in order to execute commands and to read and write data records in the Modbus buffer memories. These are described in more detail in chapter → Command lists (Page 141). The following tables list the Modbus registers used to process these commands:

Table 11-4 Command mailbox 1: Highest priority

Variable	Note	Type	Modbus registers
CMD1_CODE	Code of command to be executed	USHORT	910
CMD1_TRIGGER	Trigger for starting the command	USHORT	911
CMD1_STATUS	0=job running; 1=job finished (1 cycle)	USHORT	912
CMD1_QUIT	0=no error; <>0=error code	USHORT	913

Table 11-5 Command mailbox 2: Medium priority

Variable	Note	Type	Modbus registers
CMD2_CODE	Code of command to be executed	USHORT	920
CMD2_TRIGGER	Trigger for starting the command	USHORT	921
CMD2_STATUS	0=job running; 1=job finished (1 cycle)	USHORT	922
CMD2_QUIT	0=no error; <>0=error code	USHORT	923

Table 11-6 Command mailbox 3: Low priority

Variable	Note	Type	Modbus registers
CMD3_CODE	Code of command to be executed	USHORT	930
CMD3_TRIGGER	Trigger for starting the command	USHORT	931
CMD3_STATUS	0=job running; 1=job finished (1 cycle)	USHORT	932
CMD3_QUIT	0=no error; <>0=error code	USHORT	933

11.2.1.4 Reading registers

The method for reading registers depends on whether they belong to the writable data records (DR 3 to DR 29) or can only be read as current values (DR 30 to DR 34).

If you wish to read the registers from the data records DR 3 to DR 29, you must first export these as a complete data record to the internal output buffer.

All Modbus registers of the individual parameters can be found in chapter → Scale parameters and functions (Page 65).

Example

A parameter is to be read from data record 3 (DR 3).

- First, write register CMD3_CODE with 2003 (2000 plus the number of the data record = read data record).
- Then write CMD3_TRIGGER with "1". The DR3 is then updated in the Modbus buffer memory.
- It is now possible to read one or more registers with the corresponding variable(s). The data consistency of the registers read at this time is guaranteed.

You can find all further command numbers in chapter → Command lists (Page 141).

Example

A current measured value is to be read out from DR 30.

⇒ The register can be directly requested because its contents are automatically refreshed in the SIWAREX module at the specified measuring rate of 100 Hz and are always available up-to-date.

11.2.1.5 Writing registers

If you wish to write registers from the data records DR 3 to DR 29, you must first export the corresponding data record to the internal output buffer using an appropriate command. Individual registers can then be written. The complete data record must subsequently be written internally using an appropriate command. A plausibility check of the complete data record is carried out in the process.

Example

A parameter from DR 3 is to be written.

- First, write register CMD3_CODE with 2003 (2000 plus the number of the data record).
- Then write CMD3_TRIGGER with "1". The DR 3 is then updated in the Modbus memory.
- You can now write or change one or more registers with the corresponding variable. If you wish to transfer the written/changed registers to the scale, it is necessary to write the complete data record:
- First, write register CMD3_CODE with 4003 (4000 plus the number of the data record = write data record).
- Then write CMD3_TRIGGER with "1".
- The data record is then transferred to the process memory in the SIWAREX module. All registers of the data record are checked for plausibility in the process.

If the plausibility check fails, the complete data record is not written and a message is output to the user (from the area of data/operator errors).

You can find all further command numbers in chapter → Command lists (Page 141).

In addition, an online document is available for working with SIWAREX WP231 and Modbus → Modbus communication of WP231 (<http://support.automation.siemens.com/WW/view/de/77913998>).

Operation requiring verification

12.1 Preparing for verification

12.1.1 Calibration set

The calibration set (available as Industry Mall (<https://mallstage.industry.siemens.com/mall/en/b0/Catalog/Products/10174198?tree=CatalogTree>)) with the following contents is available for operation requiring verification:

- Information on use of the module in operation requiring verification
- EC construction license for the module
- Test certificates for the displays
- Calibration plate for covering the connection terminals
- Templates for ID labels
- Inscription foil for ID labels

You can prepare the scale verification using the calibration set.

The SecureDisplay software, a project for TIA Portal and the manual are available in the product support SIWAREX WP231 at Industry Online Support (<https://support.industry.siemens.com/cs/products/7mh4960-2aa01/siwarex-wp231-weighing-electronic?pid=184504&mlfb=7MH4960-2AA01&mfnc=ps&lc=en-VW>).

12.1.2 Scale design

If you wish to use the scale in operation requiring verification, the design must correspond to the conditions specified in the construction license. Therefore you should already take the specifications of the construction license into account when configuring and designing the scale.

12.1.3 Installation and parameterization of the main SecureDisplay for legal trade in the HMI

The SIWAREX SecureDisplay software serves as the legal trade main display of the scale. The software must be installed on the HMI prior to the verification. SIMATIC Key Panels cannot be used for SecureDisplay.

The selectable display sizes and positions on the HMI can be configured in the file, DisplayCali.xml. You can find a complete description of the software installation in the information "SIWAREX SecureDisplay".

See also

Installation of the "Software SecureDisplay for Legal-for-trade Display" from Industry Online Support (<https://support.industry.siemens.com/cs/document/109477602/software-securedisplay-for-legal-for-trade-display?dti=0&dl=en&lc=de-DE>)

12.1.4 Parameterization of the scale

The scale is parameterized prior to the verification in accordance with the envisaged use. The scale is checked and sealed during the verification. The parameters relevant to the verification cannot be changed after the verification. These are mainly the parameters in the data records DR3 and DR5. These read/write parameters are identified by "rwP" (read/write protected) in the parameter tables in Chapter 8. Certain commands cannot be used after the verification either. These are identified in the command table by "P".

12.1.5 Adjustment and preliminary checking of the scale

During commissioning, the scale adjustment (detailed description → Calibration procedure (Page 79)) is carried out following input of the scale parameters.

Depending on the type and the area of use, the scope of operations for checking the measuring properties of the scale prior to the verification may be different. A preliminary check with various calibration weights should always be carried out.

12.1.6 Calibration label

The calibration labels are edited based on the templates from the calibration set, and subsequently printed. The fields in the calibration labels can already be provided with the corresponding values prior to the verification. The protective foil is attached during the verification.

12.2 Verification

12.2.1 Checking of parameters relevant to the verification

The scale parameters are set/checked using the SIMATIC HMI operator panel.

1. Call up the main menu (function key with the open-end wrench).
2. Select the "Setup" submenu in the main menu. Select the "Advanced scale parameters" function key in the "Setup" menu.
3. The currently effective calibration parameters are shown in the display "Advanced scale parameters 1 of 4" and on the following 4 pages.

You can use the "Calibration check" submenu during the verification.

In turn, the "Calibration check" submenu branches into submenus with the contents according to the table below.

"Version and variables check" submenu	
Switch over the representation of the SecureDisplay	Display or hide the SecureDisplay using command buttons
	Switch over between 5 possible displays of variables using buttons 1 to 5
	Show smallest possible display using command button. In the area of the calibration data (display "Advanced scale parameters 4 of 4), the smallest zoom factor is applied which still results in a readily readable display size. Following the verification, users can only select larger windows for the calibration display.
Switch over contents of the SecureDisplay, the display switches back automatically to the weight display	Display SecureDisplay version
	Display calibration regulation
	Display scale data
	Display SIWAREX serial number
	Display SIWAREX firmware release
"Scale check" submenu	
Switch over contents of the SecureDisplay	x 10 increased resolution (5 s)
	Display current tare (5 s)
Scale commands	Set to zero
	Tare setting (current weight or default values)
	Delete tare
	Logging
Tare specification	Using the tare specification button you can access the form for entering various specific tare values
"Logbook check" submenu	
Display logbook entries Only the software downloads for the legal trade display SecureDisplay are retained in the logbook. It is not possible to download the firmware following verification of the scale with the jumper for write protection inserted.	Display first logbook entry
	Display last logbook entry
	Display previous logbook entry
	Display next logbook entry
"Logs" submenu	
Display logs from alibi memory	Display desired protocol via corresponding protocol ID

12.2.2 Checking of parameters relevant to the device

The following parameters relevant to the device are checked during the verification:

1. Checking of the software ID of the SecureDisplay
The software ID of the DisplayCali.exe function must agree with the requirements in the SIWAREX SecureDisplay test certificate (EC). The currently valid version can be called on the SecureDisplay.
 - Call up the main menu in the main display (function key with the open-end wrench).
Select the "Calibration check" submenu in the main menu.
 - Select the "Version and variables check" submenu in the "Calibration check" submenu.
 - Activate the "Display SecureDisplay version" command.
 - The version of the SecureDisplay is then shown on the display.
2. Checking of the firmware ID of the SIWAREX WP231 evaluation electronics
The firmware ID of the SIWAREX WP231 evaluation electronics must agree with the requirements in the EC construction license. The currently valid version can be called on the SecureDisplay.
 - Call up the main menu in the main display (function key with the open-end wrench).
Select the "Calibration check" submenu in the main menu.
 - Select the "Version and variables check" submenu in the "Calibration check" submenu.
 - Activate the "Display SIWAREX firmware release" command.
 - The current SIWAREX firmware release is then shown on the display.
3. Checking of the smallest zoom factor for the SecureDisplay display software
The zoom factor entered in DR3 for the alternative display size must comply with the minimum readability and font requirements of EN 45501, Chapter 4.2.1.
The main display with the minimum zoom size can be checked for readability.
 - Call up the main menu in the main display (function key with the open-end wrench).
Select the "Calibration check" submenu in the main menu.
 - Select the "Version and variables check" submenu in the "Calibration check" submenu.
 - Activate the "Display smallest SecureDisplay" command.
 - The smallest main display is then output and can be checked for readability.

4. Checking of the logbook entries

Only the software downloads for the legal trade display SecureDisplay are retained in the logbook. It is no longer possible to download the firmware for the SIWAREX WP231 evaluation electronics following verification of the scale with the jumper for write protection inserted.

 - Call up the main menu in the main display (function key with the open-end wrench). Select the "Calibration check" submenu in the main menu.
 - Select the "Logbook check" submenu in the "Calibration check" submenu.
 - Navigate in the logbook entries using 4 commands:
 - Display first logbook entry
 - Display last logbook entry
 - Display previous logbook entry
 - Display next logbook entry
5. Checking of the ID labels

Checking is carried out in accordance with the specifications in the EC construction license.
6. Checking of the serial number of the evaluation electronics

The serial number of the evaluation electronics used (shown at top right in the SecureDisplay) must agree with the ID label. The serial number of the evaluation electronics used can also be called on the SecureDisplay.

 - Call up the main menu in the main display (function key with the open-end wrench). Select the "Calibration check" submenu in the main menu.
 - Select the "Version and variables check" submenu in the "Calibration check" submenu.
 - Activate the "Display SIWAREX serial number" command.
 - The current serial number is then shown on the display.
7. Checking of the regulation code

Check whether the regulation code "OIML" is set in the scale parameters. The code can be called on the SecureDisplay.

 - Call up the main menu in the main display (function key with the open-end wrench). Select the "Calibration check" submenu in the main menu.
 - Select the "Version and variables check" submenu in the "Calibration check" submenu.
 - Activate the "Display calibration regulation" command.
 - The currently set code is then shown on the display.
8. Checking of the additive tare range

When using the additive tare compensation unit, you must check the complete weighing range (up to maximum load + additive maximum tare load). To do this, you must check up to the maximum load, and repeat this following taring. Repeat these steps until the upper limit of the range of the additive tare compensation unit has been reached.

 - Call up the main menu in the main display (function key with the open-end wrench). Select the "Calibration check" submenu in the main menu.
 - Select the "Scale check" submenu in the "Calibration check" submenu.
 - Check with the "Tare setting" or "Delete tare" command.

12.2 Verification

9. Checking of the parameter disabling/calibration bridge

The calibration bridge must be inserted on the weighing module. You can check the calibration bridge using the specific symbol  at the bottom right in the main display (symbol displayed = calibration bridge inserted).

10. When using the second display S102 - checking of set telegram address

The telegram address (No. 01) must be set on the Siebert display S102. Checking is carried out in accordance with the specifications in the Instruction Manual "Siebert series S102 - digital displays for Siemens Siwarex".

Technical data

24 V power supply

Note

A protective extra-low voltage (to EN 60204-1) is to be ensured by system power supply.

Rated voltage	24 V DC
Static low / high limits	19.2 V DC / 28.8 V DC
Dynamic low / high limits	18.5 V DC / 30.2 V DC
Non-periodic overvoltages	35 V DC for 500 ms with a recovery time of 50 s
Maximum current consumption	200 mA with 24 V DC
Typical power loss of the module	4.5 W

Power supply from SIMATIC S7 backplane bus

Current consumption from S7-1200 backplane bus	Typically 3 mA
--	----------------

Analog load cell interface connection

Error limit to DIN1319-1 at 20 °C +10 K	≤ 0.05% v.E. ¹⁾	
Accuracy according to EN45501 / OIML R76	• Class	III (and IV 1000d)
	• Resolution (d=e)	3000d
	• Error percentage pi	0.4
	• Step voltage	0.5 µV/e
Accuracy delivery state ²⁾	Typ. 0.1% v.E.	
Sampling rate	100 Hz	
Input signal resolution	± 4000000	
Measuring range	± 4 mV/V	
Maximum cable length between junction box ↔ WP231/WP251	1000 m (3280 ft)	
Common mode voltage range	0 V to 5 V	
Supply of the full bridge	4.85 V DC +2/-3 %	
Short-circuit and overload protection	Yes	
Connection	6-wire	
Sensor voltage monitoring	≤ 0.3 V	

Resistance of full bridge min.	• Without Ex-i interface SIWAREX IS	40 Ω
	• With Ex-i interface SIWAREX IS	50 Ω
Resistance of full bridge max.		4100 Ω
Temperature coefficient range		≤ ± 5 ppm/K v. E.
Temperature coefficient zero point		≤ ± 0.1 μV/K
Linearity error		≤ 0.002 %
Measured value filtering		Low pass
Electrical isolation		500 V AC
50 Hz / 60 Hz noise suppression CMRR		> 80 dB
Input resistance	• Signal cable	Typ. 5*10 ⁶ Ω
	• Sensor cable	Typ. 60*10 ⁶ Ω

- 1) Relative accuracy! (Absolute accuracy is only achieved by calibration on-site with calibration standard)
 2) Accuracy for module replacement or theoretical Calibration decisive
 3) Value valid at sensor; voltage drops on cables are compensated up to 5 V

Analog output

The set replacement value is output in case of a fault or SIMATIC CPU stop.

Error limit according to DIN 1319-1 of full-scale value at 20 °C +10 K	0 ... 20 mA: ≤ 0.5 % 4 ... 20 mA: ≤ 0.3 %
Refresh rate	10 ms
Resolution	16-bit
Measuring ranges	0 mA to 20 mA 4 mA to 20 mA
Max. output current	24 mA
Error signal (if configured (FW))	22 mA
Max. load	600 Ω
Temperature coefficient range	≤ ± 25 ppm/K v. E.
Temperature coefficient zero point	typ. ± 0.3 μA/K
Linearity error	≤ 0.05 %
Electrical isolation	500 V AC
Cable length	max. 100 m, twisted and shielded

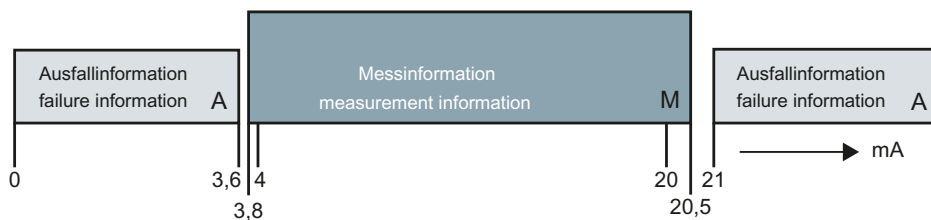

Figure 13-1 Current ranges for signal level to Namur recommendation NE43

Digital outputs (DQ)

The set value is output at the digital output in case of a fault or SIMATIC CPU stop.

A freewheeling diode has to be installed at the consumer with inductive loads at the digital output.

Quantity	4 (high-side switch)
Supply voltage range	19.2 V DC to 28.8 V DC
Max. output current per output	0.5 A (ohmic load)
Max. total current for all outputs	2.0 A
Refresh rate (FW)	100
Switching delay	Typ. 25 µs turn on Typ. 150 µs turn off
RDSON	< 0.25 Ω
Short-circuit proof	Yes
Electrical isolation	500 V AC
Cable length (meter)	Max. 500 m shielded, 150 m unshielded

Digital inputs (DI)

Number of inputs	4
Rated voltage	24 V DC
Supply voltage range	max. 30 V DC
Power consumption at 24 V DC	4 mA
Voltage surge	35 V DC for 0.5 s
Logical signal level 1 (min)	15 V DC at 2.5 mA
Logical signal level 0 (max)	5 V DC at 1.0 mA
Sampling rate (FW)	10 ms
Filtering	0.2, 0.4, 0.8, 1.6, 3.2, 6.4 and 12.8 ms
Electrical isolation	500 V DC

Real-time clock

Accuracy at 25 °C	< +/- 15 s/day
Buffered period	Typ. 10 days at 25 °C min. 6 days at 40 °C

RS485 interface

Standard	EIA-485
Baud rate	Up to 115 Kbps
Data bits	7 or 8
Parity	even odd none
Stop bits	1 or 2

Terminating resistors (can be activated)	390 Ω / 220 Ω / 390 Ω
Electrical isolation	500 V AC
Transfer protocol	<ul style="list-style-type: none"> • Display from the company Siebert, type S102 See section: Connection of Siebert display via RS485 (Page 38) • Operator Panels or other HMI devices with RS485 and Modbus protocol RTU • Communication partner with Modbus protocol RTU • SIWAREX DB See section: Connection of the SIWAREX DB (Page 43)
Cable length	≤ 115 kbps max. 1 000 m (fieldbus cable 2-wire, shielded, e.g. 6XV1830-0EH10)

Ethernet

Standard	IEEE 802.3	
Transmission rate	10/100 Mbps (determined automatically)	
Electrical isolation	1 500 V AC	
Transfer protocol	TCP/IP, Modbus TCP (see /1/)	
Autonegotiation	Yes	
Auto MDI-X	Yes	
Cable lengths	<ul style="list-style-type: none"> • Cat-5e UTP cable (unshielded) 	Max. 50 m
	<ul style="list-style-type: none"> • Cat-5e SF/UTP cable (shielded) 	Max. 100 m

Dimensions and weights

Dimensions W x H x D	70 x 100 x 75 mm
Weight	300 g

Mechanical requirements and data

Testing	Standards	Test values
Vibrational load during operation	IEC 61131-2 IEC 60068-2-6 Test Fc	5 to 8.4 Hz: 3.5 mm out. 8.4 to 150 Hz: 9.8 m/s ² (=1G) 0 cycles per axis 1 octave / min.
Shock load during operation	IEC 61131-2 IEC 60068-2-27 Test Ea	150 m/s ² (approx. 15 g), half sine Duration: 11 ms Quantity: 3 each per axis in negative and positive direction
Vibration load during transport	IEC 60068-2-6 Test Fc	5 to 8.4 Hz: 3.5 mm out. 8.4 Hz ... 500 Hz: 9.8 m/s ² 10 cycles per axis 1 octave / min.
Shock load during transport	IEC 60068-2-27: Test Ea	<ul style="list-style-type: none"> • 250 m/s² (25G), half sine • Duration: 6ms • Quantity: 1 000 each per axis • in negative and positive direction
Free fall	IEC 61131-2 IEC 60068-2-31: Test Ec, procedure 1	<ul style="list-style-type: none"> • For devices < 10 kg: • In product packaging: 300 mm drop height • In shipping package: 1.0 m drop height • per 5 attempts

13.1 Electrical, EMC and climatic requirements

Electrical protection and safety requirements

Fulfilled requirement	Standards	Comments
Safety regulations	IEC 61010-1 IEC 61131-2; UL 508 CSA C22.2 No.142	
Protection class	IEC 61140	Module is operated with protective extra-low voltage. The protective conductor connection serves only a functional earth to dissipate interference currents

13.1 Electrical, EMC and climatic requirements

Fulfilled requirement	Standards	Comments
IP degree of protection	IP20 in accordance with IEC 60529	<ul style="list-style-type: none"> Protection against contact with standard probe Protection against solid bodies with diameters in excess of 12.5 mm No special protection against water
Air gaps and creepage distances	IEC 60664 IEC 61131-2 IEC 61010-1 UL 508 CSA C22.2 No. 145 EN 50156-1	Overvoltage category II Pollution degree 2 PCB material IIIa Conductor path distance 0.5 mm
Isolation stability	IEC 61131-2 CSA C22.2, No. 142 UL508	Ethernet port: 1500 V AC (shield and signals) Additional electrical circuits: Test voltage: 500 V AC or 707 V DC Test duration: ≥ 1 minute Short circuit current: ≥ 5 mA

Electromagnetic compatibility

Table 13-1 Requirements: Interference emission in industrial area in accordance with EN 61000-6-4

Comments	Standard	Limits
Emission of radio interferences (electromagnetic fields)	Class A industrial environment: EN 61000-6-4 IEC/CISPR 16-2-3: 2008	<ul style="list-style-type: none"> 30 ... 230 MHz, 40 dB (µV/m) Q 230 ... 1000 MHz, 47 dB (µV/m) Q
Emission on power supply cables 24 V	Class A: Industrial environment: EN 61000-6-4 IEC/CISPR 16-2-1: 2010; EN 55016-2-1: 2009	Class A: Industrial environment <ul style="list-style-type: none"> 0.15 ... 0.5 MHz, 79 dB (µV) Q 0.15 ... 0.5 MHz, 66 dB (µV) M 0.5 ... 30 MHz, 73 dB (µV) Q 0.5 ... 30 MHz, 60 dB (µV) M
Emission conducted Ethernet	EN 61000-6-4	0.15 ... 0.5 MHz: <ul style="list-style-type: none"> 53 dB (µA) to 43 dB (µA) Q 40 dB (µA) – 30 dB (µA) M 0.5 ... 30 MHz: <ul style="list-style-type: none"> 43 dB (µA) Q / 30 dB (µA) M

Table 13-2 Requirements: Interference immunity in industrial area in accordance with EN 61000-6-2

Comments	Standard	Severity class
Burst pulses on power supply cables	EN45501 OIML R76	1 kV
Burst pulses on data and signal cables	EN 61000-4-4 NAMUR NE21 EN 61326	2 kV
Electrostatic discharge (ESD)	EN 61000-4-2 NAMUR NE21 EN 61326 EN45501 OIML R76	6 kV direct/indirect
Electrostatic air discharge (ESD)	EN 61000-4-2 NAMUR NE21 EN 61326 EN 45501 OIML R76	8 kV
Surge on power supply cables	EN 61000-4-5 IEC 61131-2 NAMUR NE21 EN 61326	<ul style="list-style-type: none"> • 1 kV symmetric • 2 kV asymmetric
Surge on data and signal cables	EN 61000-4-5 IEC 61131-2 NAMUR NE21 EN 61326	<ul style="list-style-type: none"> • 1 kV symmetric¹⁾ • 2 kV asymmetric
HF irradiation amplitude modulated	IEC61000-4-3 NAMUR NE21 OIML R76 EN 45501*3	<ul style="list-style-type: none"> • 80 ... 2000 MHz: 12 V/m • Mod.: 80% AM with 1 kHz <p>Note: In the ranges 87 ... 108 MHz, 174 ... 230 MHz and 470 ... 790 MHz: 3 V/m</p>
HF irradiation, cell phone frequencies	IEC 61000-4-3	<ul style="list-style-type: none"> • 900 MHz (± 5 MHz) • 1.89 Ghz (± 10 MHz) • 10 V/m
HF voltage on data, signal and power supply cables 0.15 to 80 MHz	IEC 61000-4-6 NAMUR NE21 EN 61326 OIML R76	<ul style="list-style-type: none"> • 10 kHz to 80 MHz: 10 Veff • Mod.: 80% AM with 1 kHz

¹⁾ Not applicable for shielded cables and symmetric ports

* An external protection element has to be installed to meet the requirement (e.g.: Blitzductor VT AD24V, Dehn&Söhne)

NOTICE
Radio interference is possible
This is a device of class A. The device may cause radio interference in residential areas. Implement appropriate measures (e.g.: use in 8MC cabinets) to prevent radio interference.

Ambient conditions

The use of SIWAREX WP is intended under the following conditions in SIMATIC S7-1200. Additionally observe the operating conditions of the S7-1200 system.

Table 13-3 Operating conditions in accordance with IEC 60721

Mode	IEC 60721-3-3 • Class 3M3, 3K3, stationary use, weather-proofed
Storage/transport	IEC 60721-3-2 • Class 2K4 without precipitation

Table 13-4 Climatic requirements

Comments		Ambient conditions	Application areas
Operating temperature:	Horizontal installation in S7-1200	-10 ... +55 °C	
	Vertical installation in S7-1200	-10 ... +40 °C	
	Operation with verification capability	-10 ... +40 °C	
Storage and transport temperature		- 40 ... +70 °C	
Relative humidity		5 ... 95 %	No condensation; corresponds to relative humidity (RH) stress level 2 to DIN IEC 61131-2
Contaminant concentration		SO ₂ : < 0.5 ppm H ₂ S: < 0.1 ppm;	RH < 60%, no condensation
Atmospheric pressure	Operation	IEC 60068-2-13	1080 ... 795 hPa (operation) (-1000 ... +2000 m above sea level)
	Transport and storage	IEC 60068-2-13	1080 ... 660 hPa (storage) (-1000 ... +3500 m above sea level)

Mean Time Between Failure (MTBF)

The MTBF calculation results in the following value:

Table 13-5 MTBF









Electronic Weighing System	MTBF in years
SIWAREX WP231/WP241/WP251	971 years @TA = 40 °C

13.2 Approvals

NOTICE
Safety guidelines for applications in hazardous areas
For applications in hazardous areas, read the safety instructions in the document "Product Information - Use of SIWAREX Modules in a Zone 2 Hazardous Area (https://support.industry.siemens.com/cs/ww/en/)".

Note

The current approvals for SIWAREX WP231 can be found on the module nameplate.

	→ CE approval (http://support.automation.siemens.com/WW/view/de/65692972)
	→ cULus approval (http://support.automation.siemens.com/WW/view/de/74442065)
	→ Ex approval (http://support.automation.siemens.com/WW/view/de/81803667)
	→ KCC approval
	→ EU Qualification Approval (https://support.industry.siemens.com/cs/de/de/view/109477266/en) → OIML certificate (https://support.industry.siemens.com/cs/de/de/view/109482443/en)
	→ EAC certificate (https://support.industry.siemens.com/cs/ww/de/view/109476219/en)
	→ Tick mark for Australia and New Zealand
	→ The modules are RoHS-compliant according to EU Directive 2016/65/EU

Ordering data

You can order accessories online: Industry Mall (<https://mallstage.industry.siemens.com/mall/en/b0/Catalog/Products/10174198?tree=CatalogTree>)

Digital remote display

The digital remote displays can be connected directly through the RS485 interface to the SIWAREX WP231, SIWAREX WP251, SIWAREX WP321, SIWAREX WP52x and SIWAREX FTA.

Suitable remote display: S102

Siebert Industrieelektronik GmbH

Postfach 1180

D-66565 Eppelborn, Germany

Tel.: 06806/980-0

Fax: +49 (0)6806/980-999

Internet: Siebert Industrieelektronik GmbH (<http://www.siebert-group.com/en/index.php>)

You can obtain more detailed information from the manufacturer.

Product documentation and support

A.1 Product documentation

Product documentation for process instrumentation is available in the following formats:

- Certificates (<http://www.siemens.com/processinstrumentation/certificates>)
- Downloads (firmware, EDDs, software) (<http://www.siemens.com/processinstrumentation/downloads>)
- Catalogs and technical data sheets (<http://www.siemens.com/processinstrumentation/catalogs>)
- Manuals (<http://www.siemens.com/processinstrumentation/documentation>)
You have the option to view, open, save or configure the manual.
 - "Display": The manual opens in HTML5 format.
 - "Configure": You can register and configure the specific documentation for your plant here.
 - "Download": The manual is opened or saved in PDF format.
 - "Download as html5, only PC": The manual is opened or saved in HTML5 view on your PC.

You can also find manuals at Industry Online Support (<https://support.industry.siemens.com/cs/ww/de/sc/2067>) using the mobile app. Download the app to your mobile device and scan the QR code.

See also

Generally applicable information/SIMATIC manual overview (<https://support.industry.siemens.com/cs/ww/en/view/109742709>)

A.2 Technical support

Technical support

If this documentation does not completely answer your technical questions, you can enter a Support Request (<http://www.siemens.com/automation/support-request>).

Additional information on our technical support can be found at Technical Support (<http://www.siemens.com/automation/csi/service>).

Service & support on the Internet

In addition to our technical support, Siemens offers comprehensive online services at Service & Support (<http://www.siemens.com/automation/serviceandsupport>).

Contact

If you have further questions about the device, contact your local Siemens representative at Personal Contact (<http://www.automation.siemens.com/partner>).

To find the contact for your product, go to "all products and branches" and select "Products & Services > Industrial automation > Process instrumentation".

Contact address for business unit:

Siemens AG
Digital Industries
Process Automation
Östliche Rheinbrückenstr. 50
76187 Karlsruhe, Germany

SIWAREX support

- Email (<mailto:hotline.siwarex@siemens.com>)
- Phone: +49 (721) 667-1200 CET 8:00 to 17:00

ESD guidelines

B.1 ESD Guidelines

Definition of ESD

All electronic modules are equipped with large-scale integrated ICs or components. Due to their design, these electronic elements are highly sensitive to overvoltage, and thus to any electrostatic discharge.

The electrostatic sensitive components/modules are commonly referred to as ESD devices. This is also the international abbreviation for such devices.

ESD modules are identified by the following symbol:



NOTICE

ESD devices can be destroyed by voltages well below the threshold of human perception. These static voltages develop when you touch a component or electrical connection of a device without having drained the static charges present on your body. The electrostatic discharge current may lead to latent failure of a module, that is, this damage may not be significant immediately, but in operation may cause malfunction.

Electrostatic charging

Anyone who is not connected to the electrical potential of their surroundings can be electrostatically charged.

The figure below shows the maximum electrostatic voltage which may build up on a person coming into contact with the materials indicated. These values correspond to IEC 801-2 specifications.

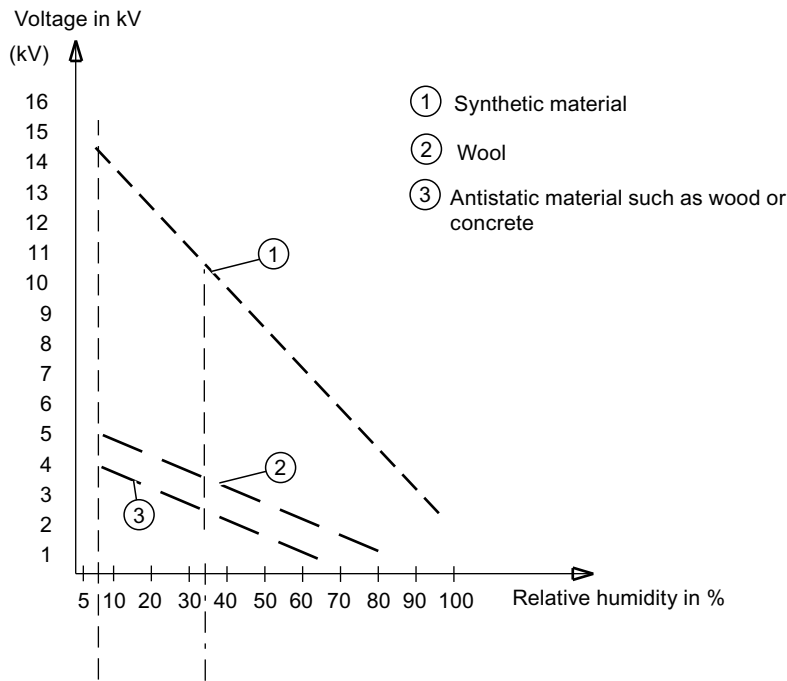

Figure B-1 Electrostatic voltages which an operator can be subjected to

Basic protective measures against electrostatic discharge

- Ensure good equipotential bonding:
When handling electrostatic sensitive devices, ensure that your body, the workplace and packaging are grounded. This prevents electrostatic charge.
- Avoid direct contact:
As a general rule, only touch electrostatic sensitive devices when this is unavoidable (e.g. during maintenance work). Handle the modules without touching any chip pins or PCB traces. In this way, the discharged energy can not affect the sensitive devices. Discharge your body before you start taking any measurements on a module. Do so by touching grounded metallic parts. Always use grounded measuring instruments.

Abbreviations

ASCII	American Standard Code for Information Interchange
B	Gross weight
CPU	Central processor, in this case SIMATIC CPU
DB	Data block
FB	SIMATIC S7 function block
HMI	Human machine interface (e.g. SIMATIC Operator Panel)
HW	Hardware
NAWI	Non-automatic weighing instrument
NAW	Non-automatic scales
OIML	Organisation Internationale de Metrologie Legale
OP	Operator Panel (SIMATIC)
PC	Personal computer
pT	Preset tare (predefined tare weight with manual taring)
RAM	Random access memory
PLC	Programmable logic controller
STEP 7	Programming device software for SIMATIC S7
T	Tare weight
TM	Technology module
TP	Touch Panel (SIMATIC)
UDT	Universal Data Type (S7)
WRP	Write protection
LC	Load cell(s)
NR	Numerical range

Index

A

ASCII, 121

C

Calibration parameters, 66

Catalog

Technical data sheets, 177

Certificates, 177

Connections, 30

Customer Support, (Refer to Technical support)

D

Date and time, 127

Data record, 96

Default for control of the analog output, 109

Default for control of the digital outputs, 110

Display duration

Parameter, 127

Display of data and operator errors, 118

Documentation

Edition, 12

Downloads, 177

E

Electrical, 169

protection requirement, 169

ESD guidelines, 179

Ethernet parameters, 100

G

Guidelines

ESD guidelines, 179

H

History, 12

Hotline, (Refer to Support request)

L

Log content

Data record, 123

Log request

Data record, 122

Logbook, 125

M

Main display value ASCII, 121

Manuals, 177

Module info, 97

P

Parameter

Display duration, 127

Parameter string

Digital load cell, 127

Parameters of the analog load cells, 98

Process value

Data record, 111, 115

protection requirement

Electrical, 169

R

Reliability, 172

RS485 interface, 103

S

safety requirement, 169

Electrical, 169

Scope of delivery, 13

Service, 177

Service and support

Internet, 177

Simulation value, 108

Support, 177

Support request, 177

T

Technical support, 177
 partner, 178
 personal contact, 178

W

Warranty, 14

Z

Zeroing memory, 83