

SIEMENS

SIWAREX MS

Weighing Module for Level Measurement, Weighbridges etc.
Calibrating SIWAREX MS with SIWATOOL MS

Quick Guide

For modules with order number 7MH4930-0AA01

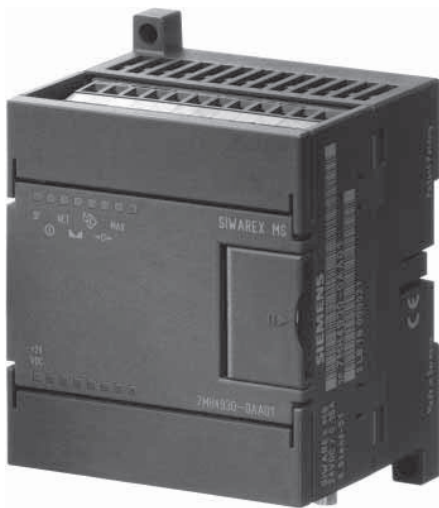

Contents

1. Hardware Requirements	3
2. Siwarex MS connections	6
3. Establish the communication to the Siwarex MS module	8
4. Adjustment with an adjustment weight.....	9
4.1 Set the SIWATOOL parameters.....	9
4.2 Adjustment procedure	12
5. Adjustment without an adjustment weight (theoretical adjustment)	14
6. Create a Siwatool backup file	18

Introduction

SIWAREX MS is a compact weighing module for SIMATIC Automation System S7-200. Main applications are bin scales, weighbridges, crane scales, force and tightening torque measuring.

Purpose of this document for functional safety

This programming manual contains all information that you will require to commission and use the device.

It is aimed at persons who install the device mechanically, connect it electrically, parameterize and commission it, as well as at service and maintenance engineers.

Notes on warranty

The contents of this programming manual shall not become part of or modify any prior or existing agreement, commitment or legal relationship. All obligations on the part of Siemens AG are contained in the respective sales contract, which also contains the complete and solely applicable warranty conditions. Any statements on the device versions described in the programming manual do not create new warranties or modify the existing warranty.

The content reflects the technical status at the time of printing. We reserve the right to make technical changes in the course of further development.

Validation of this document

This documentation is only valid in conjunction with the manual SIWAREX MS. This manual is available on the Siemens homepage.

<http://support.automation.siemens.com/WW/view/en/22600601>

1. Hardware Requirements

Following hardware parts and software are requested to integrate a scale into SIMATIC S7-200: SIWAREX MS module, 24V Power Module, S7-200 CPU, SIWATOOL MS configuration package, RS232 cable, computer with Windows XP or higher and a calibration weight bigger than 5% of the sum of the nominal value of all load cells.



24V Power Supply



SIMATIC CPU S7-200



SIWAREX MS
7MH4930-0AA01



SIWATOOL RS232 Cable
7MH4607-8CA



Configuration Package for SIWAREX MS:
7MH4930-0AK01



Adjustment weight
(>5% of the sum of the nominal value
of all load cells)



Scale

System Configuration

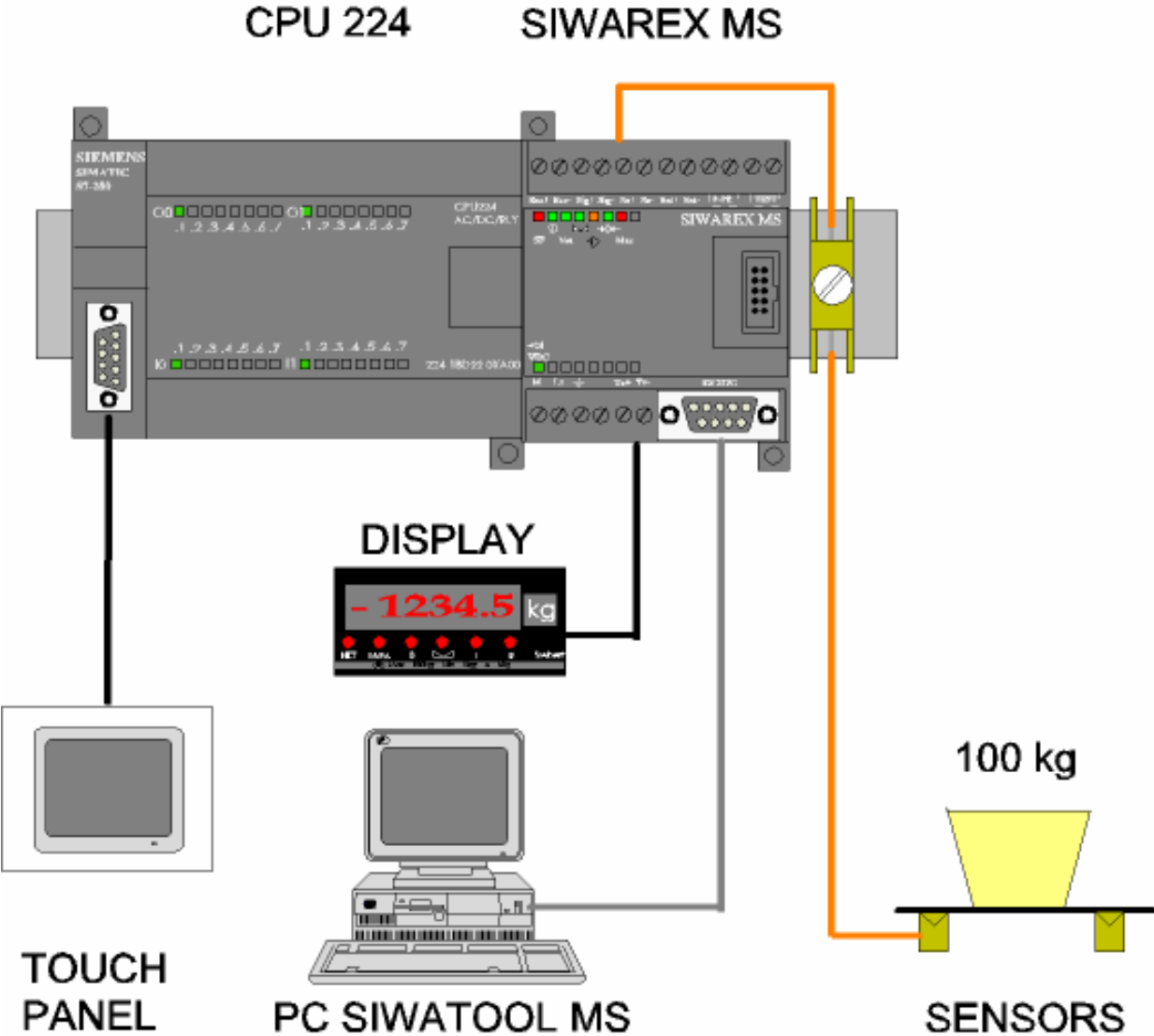

2. Siwarex MS connections

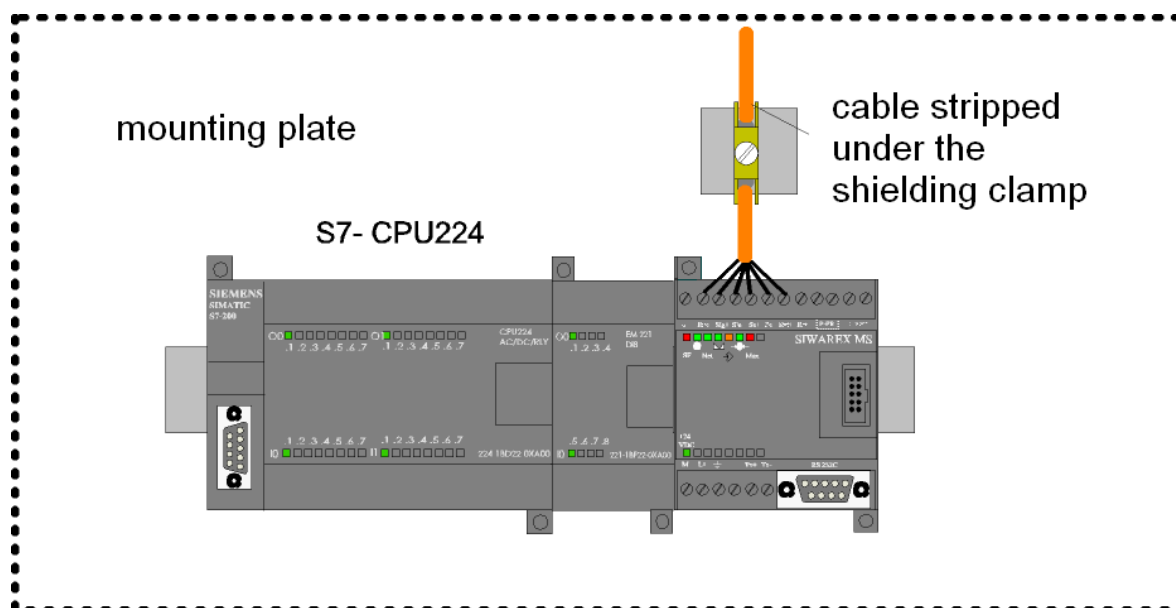

Load Cell Connection:

Connection and signal designations	Comment
SEN+	Sense line +
SEN-	Sense line -
SIG+	Measurement line +
SIG-	Measurement line -
EXC+	Load cell supply +
EXC-	Load cell supply -

Connecting the PC for SIWAREX MS:

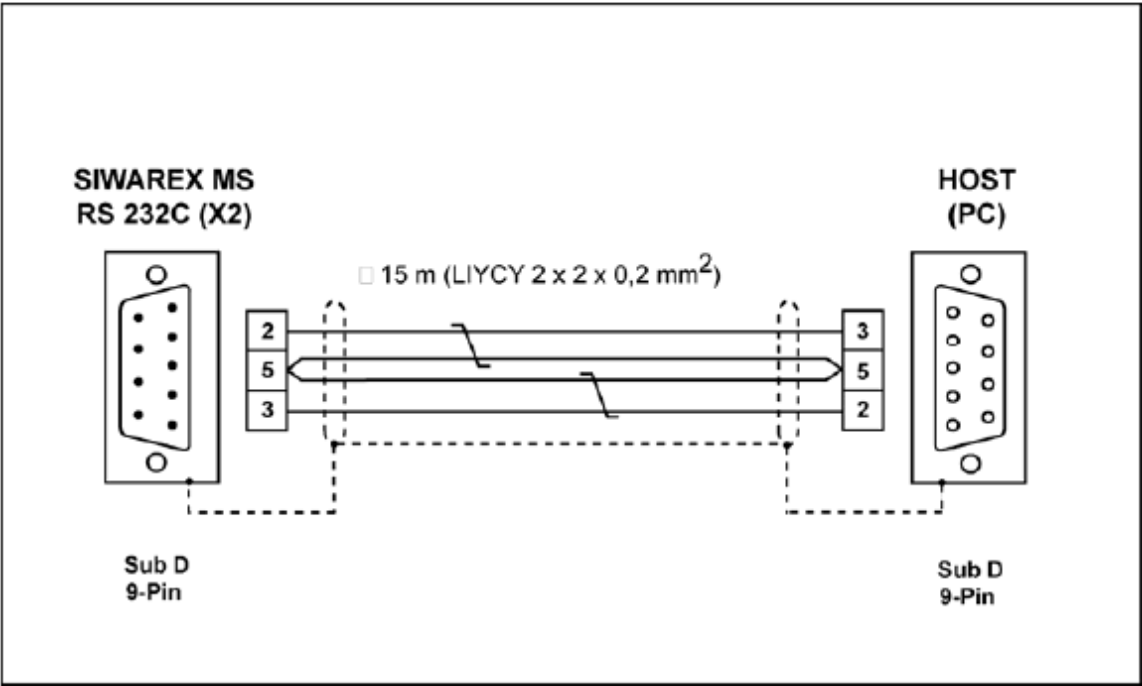

3. Establish the communication to the Siwarex MS module

Start the Siwatool MS software into Windows:

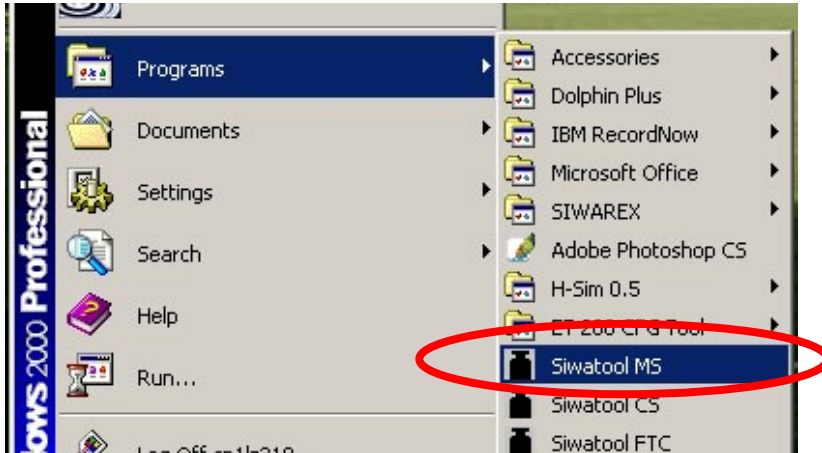

For establishing the communication between the Siwarex MS module and the Siwatool software, click the button **Online**:

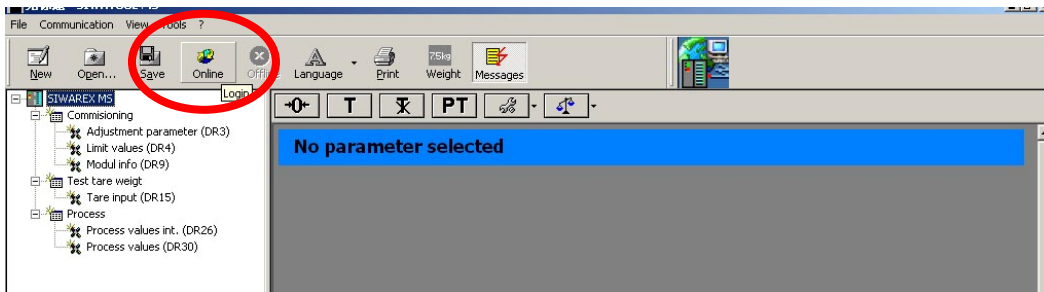

4. Adjustment with an adjustment weight

4.1 Set the SIWATOOL parameters

When the communication is established check the following parameter-settings:

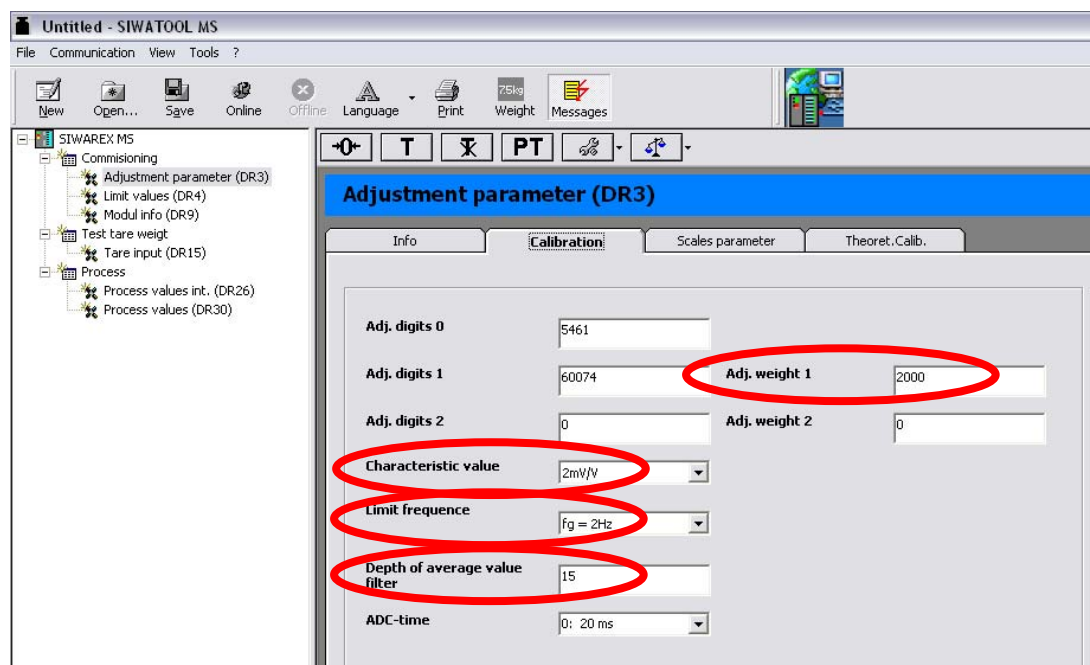

Adj.weight 1:

Enter the value of the adjustment weight.

The adjustment weight is an integer-value (up to 32767).

For example:

- a) For a 20 kg scale you may use a resolution of 1 g:
 - the parameter "Adj. weight 1" is set into gram (e.g. "20000").
 - the parameter "Numeral step" (index card "Scales parameter") is set to "1".
 - the parameter "Decimal point" (index card "Scales parameter") is set to "0".
 - the parameter "Weight unit" (index card "Scales parameter") is set to "gr".

- b) For a 40 kg scale you may use a resolution of 10 g:
 - the parameter "Adj. weight 1" is set into gram x10 (e.g. "4000").
 - the parameter "Numeral step" (index card "Scales parameter") is set to "1".
 - the parameter "Decimal point" (index card "Scales parameter") is set to "2".
 - the parameter "Weight unit" (index card "Scales parameter") is set to "kg".

The decimal point is not part of the integer-value and is only used for the Siwatool-display (and a remote display, if available).

That means the numeral step and the decimal point have to determine, so that the displayed weight value (weight value = integer-value) will not increase the value of 32767.

Characteristic Value:

Characteristic value of the load cell.

The specification of the characteristic value can be read into the technical data sheet of the load cell.

Limit frequency:

If this parameter is set to 5 Hz, the scale will respond quickly to a weight change; if it is set to 0.05 Hz, the scale will “move slowly”.

Step response of the limit frequency of 2 Hz:

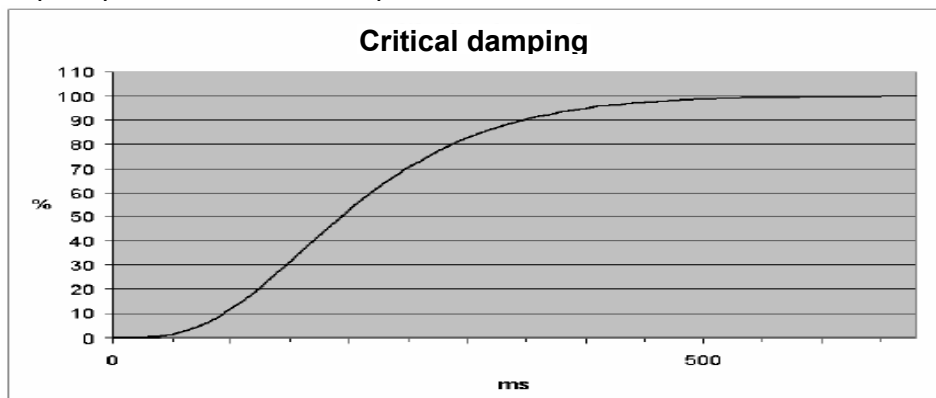

Depth of average value filter:

The average value filter ensures a stable weight value and prevents interference.

The weight is measured according to the average value of n weight values.

If n = 10, 10 weight values will be used for calculating the average value. The earliest value is discarded every 20 milliseconds and the latest value will be added for the calculation.

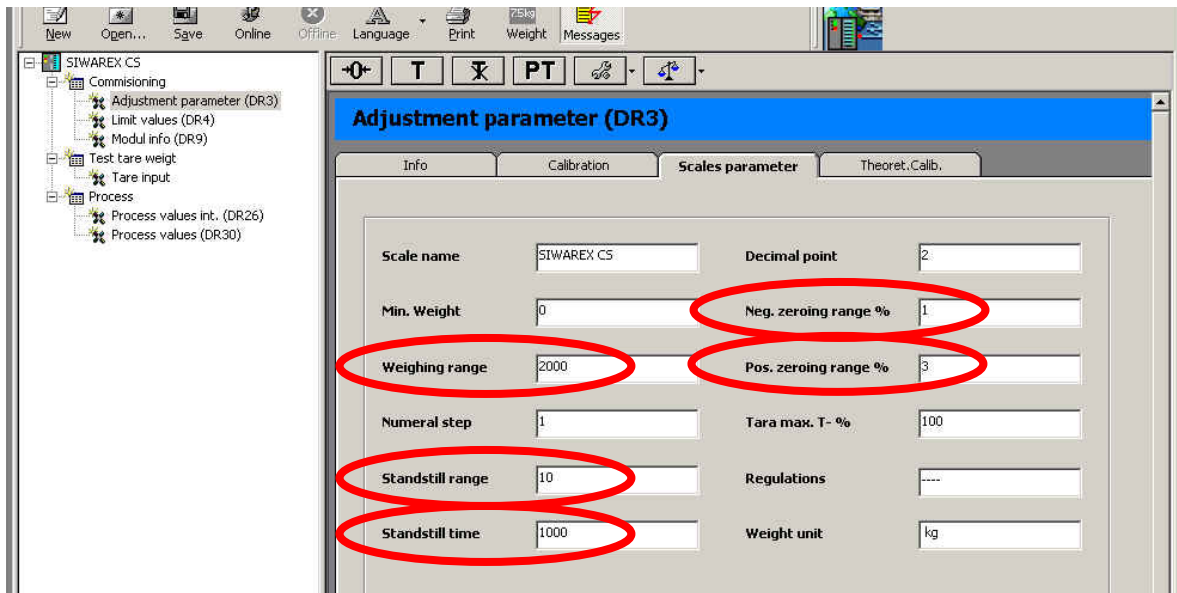

Standstill range and Standstill time:

Standstill range and Standstill time (in msec) are used to monitor when the scale has stand still.

If the weight change is lower than the specified range (standstill range) within the specified period (standstill time) the scale stands still.

The monitoring of the scale standstill is used e.g. for the commands “zeroing” or “taring”.

Neg. zeroing range %, Pos. zeroing range % and Weighing range:

By executing the command “zeroing” the weight value is set to zero. With the parameters “Neg. zeroing range %” and “Pos. zeroing range %” the zeroing range is defined. The values are set as percent of the parameter “Weighing range”.

The parameter “Weighing range” is the maximum of material, which will put on the scale.

For example (see also the picture above):

The zeroing range is between -20 kg (-1% of 2000) and +60 kg (+3% of 2000).

Zeroing will be rejected if the current gross weight is too high or too low.

After setting the parameters, click **Send** to send the changed parameters to the Siwarex MS module:

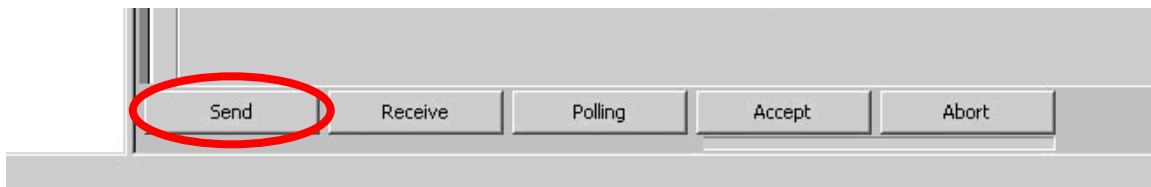

4.2 Adjustment procedure

Ensure that the scale is empty (not loaded) and execute the command **Adjustment zero valid (3)**.

The Siwarex MS module shows now the weight value “0”.

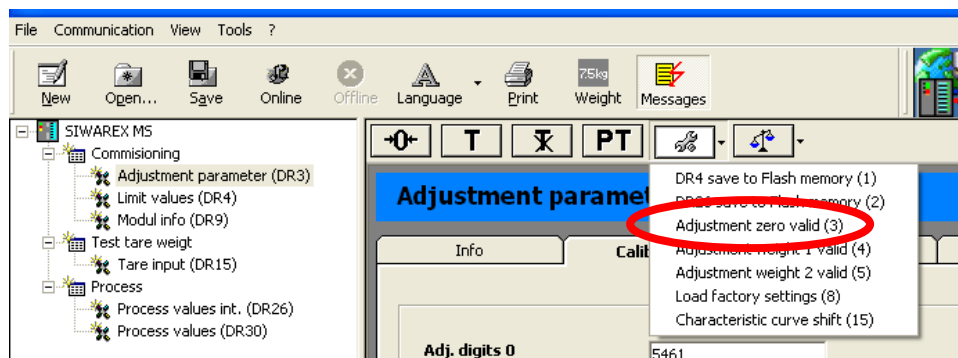
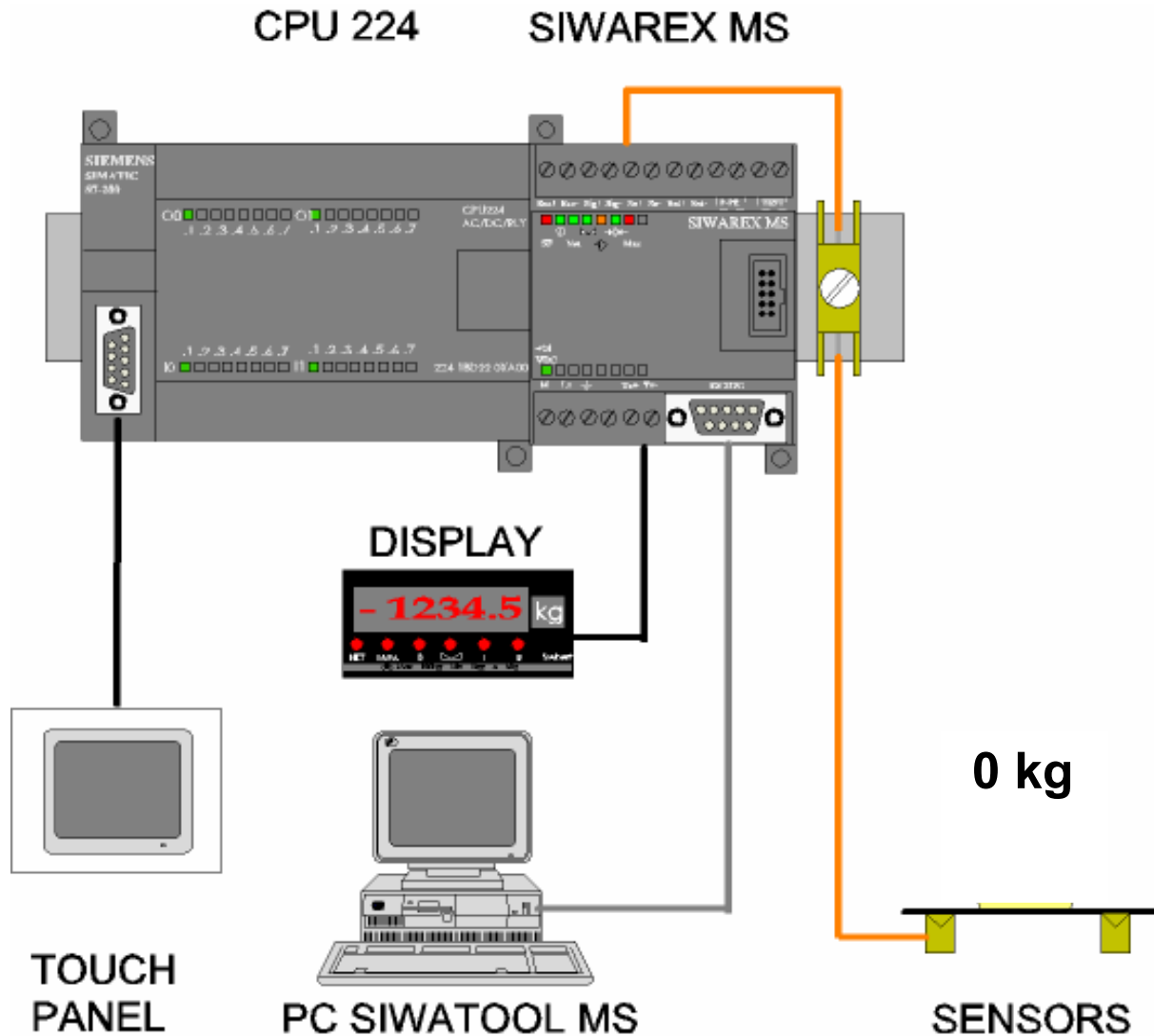

Afterwards, place the adjustment weight on the scale and execute the command **Adjustment weight 1 valid (4)**. With executing of this command, the adjustment line is detected of the scale.
 The Siwarex MS module shows now the adjustment weight.

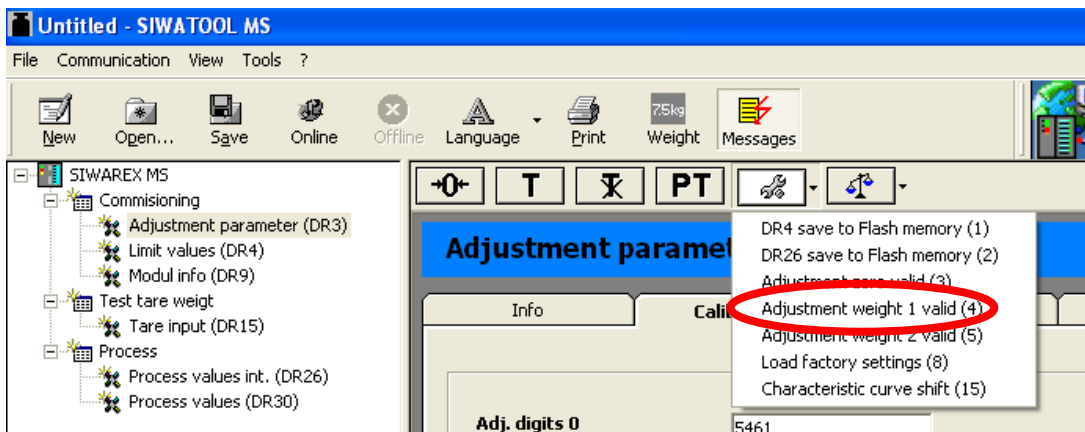
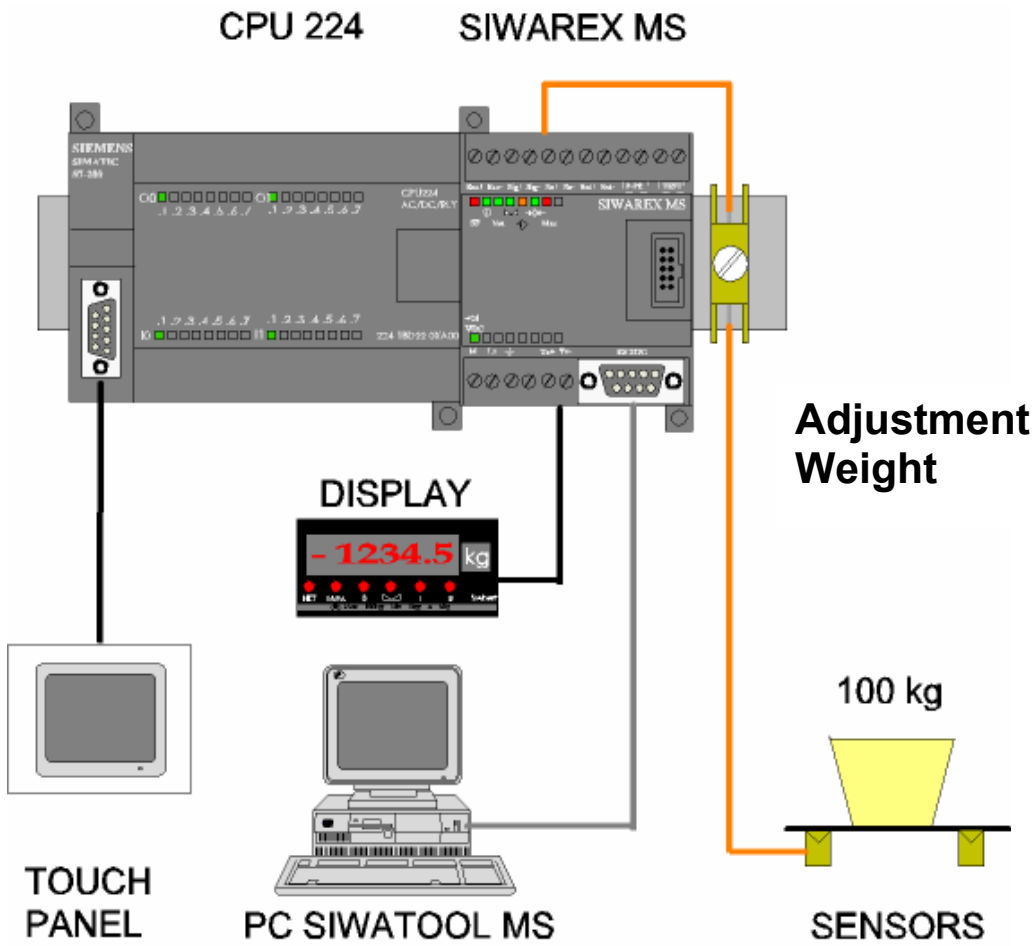

The adjustment is completed now.

5. Adjustment without an adjustment weight (theoretical adjustment)

If the adjustment is not possible by using adjustment weights, the scale can also be adjusted without adjustment weights, if the mechanical structure of the scale is correct.

If the measuring logs are available, these logs can be used for the theoretical adjustment. If the measuring logs aren't available, the default-values of the load cells can be used of the technical data sheet.

The execution of the theoretical adjustment is handled with the help of the SIWATOOL MS software.

First, the "Characteristic value" (e.g. "2 mV/V") must be defined in the DR3, index card: "Calibration":

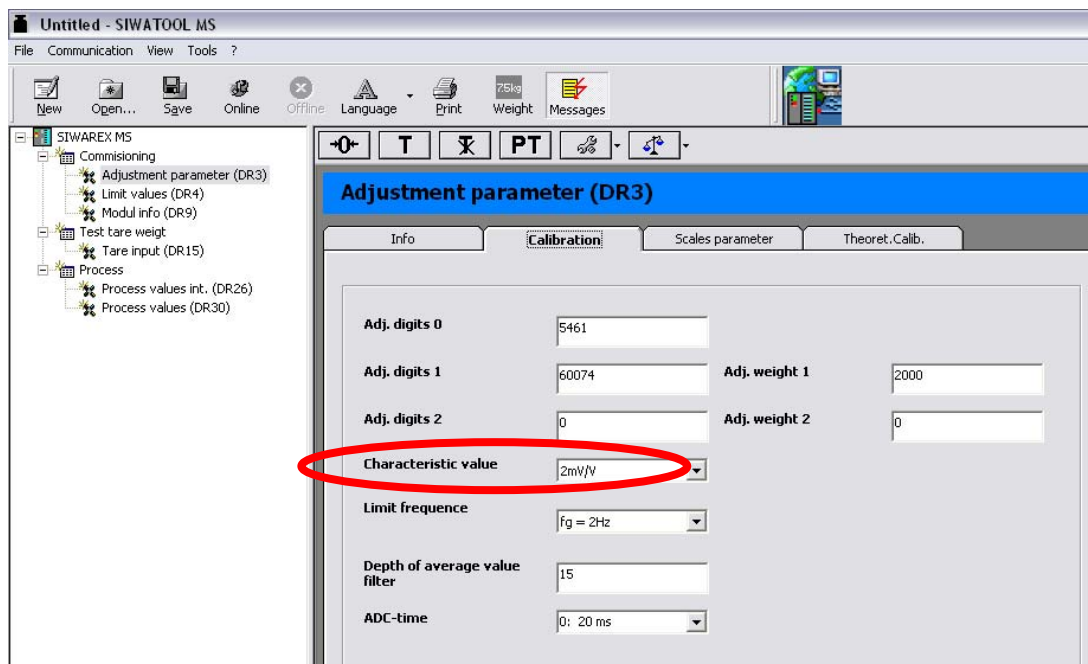

Then, switch to the "Theoret. Calib." index card.

To execute the theoretical adjustment, the rated load for all load cells is defined first, e.g. 3 load cells with 1,000 kg each result in a rated load of 3,000 kg. (See also step "1." in the picture below)

The "Zero offset in $\mu\text{V/V}$ " (unit = $\mu\text{V/V}$), and the "Characteristic value" (unit = mV/V) is then entered for each individual load cell.

(See also step "2." and "3." in the picture below)

These values are taken from the respective load cell measuring log. If the measuring logs aren't available, the default-values can be used, e.g. "Zero offset in $\mu\text{V/V}$ " = "0" and "Characteristic value" = "2.0":

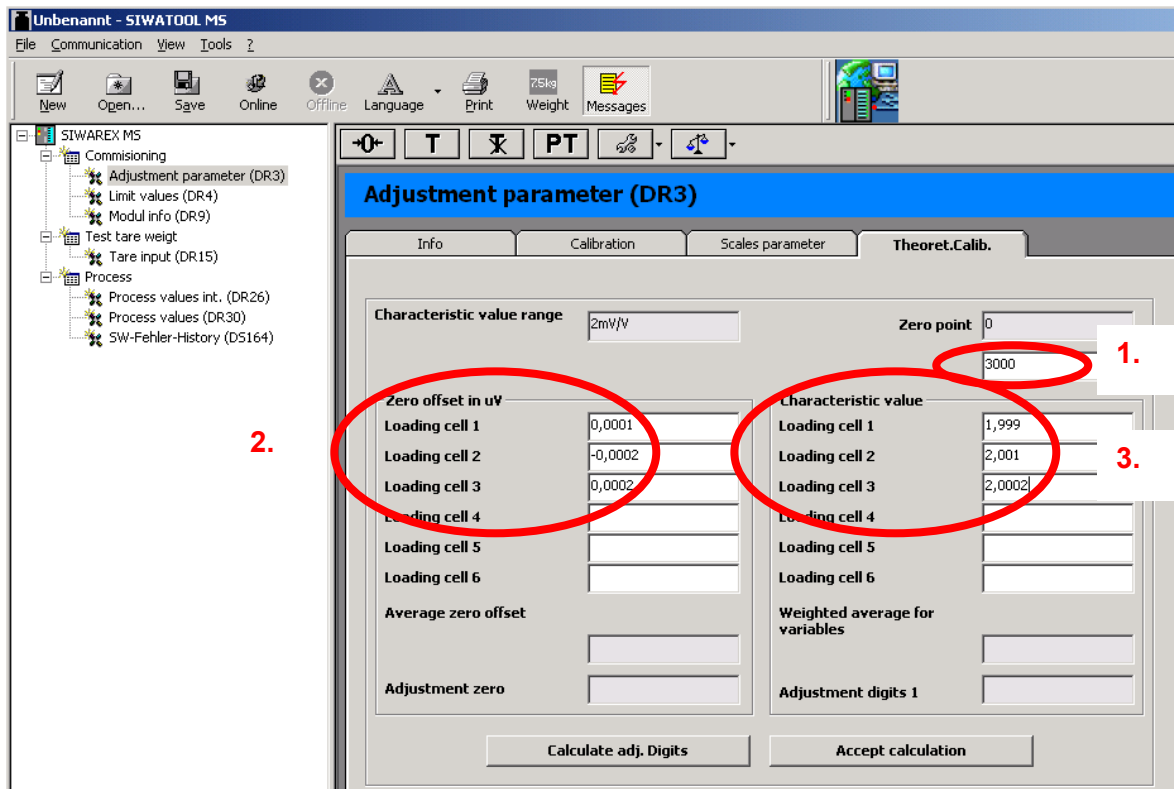

After entering the data for each load cell, the adjustment digits are calculated and the result is displayed by actuating the button "Calculate adj. Digits". Then, the calculated adjustment digits can be integrated into the DR3 by actuating the button "Accept calculation":

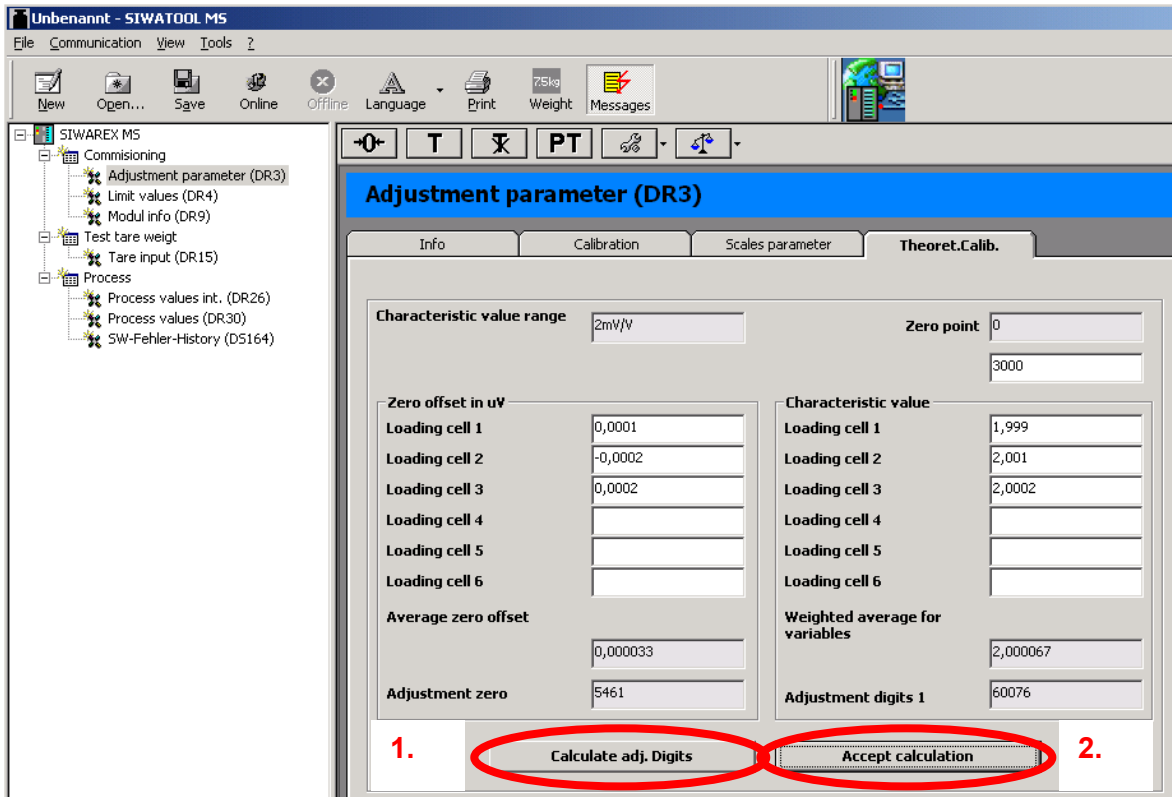

The DR3 is then sent to the weight module with the new adjustment data with the button "Send":

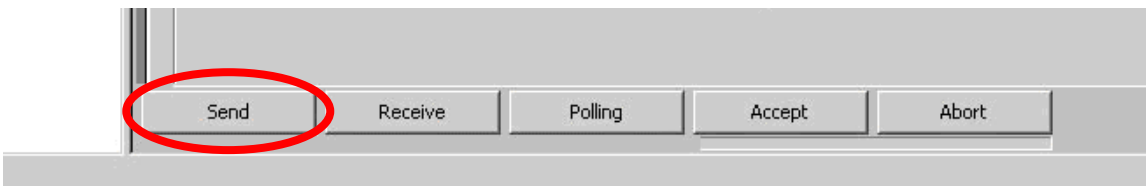

After sending the DR3, the command "Characteristic curve shift (15)" has to be executed, when the scale is empty.

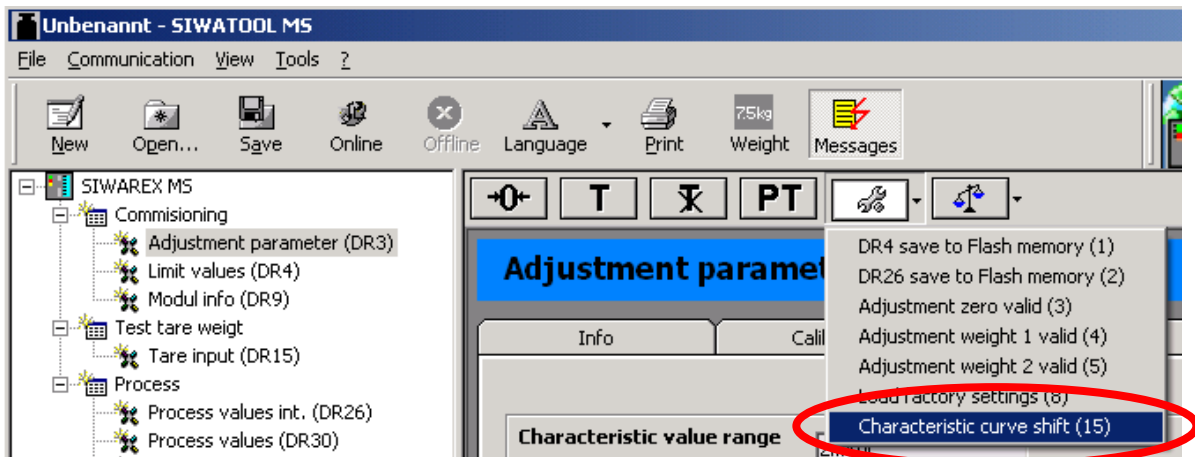

The theoretical adjustment is now finished.

6. Create a Siwatool backup file

Eventually you may save all parameter settings of the Siwarex MS module into a file

Receive all data from the Siwarex MS module the Siwatool software:

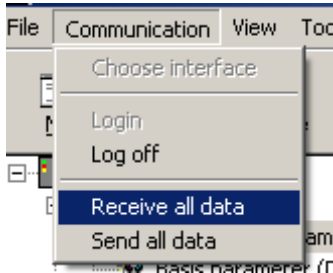

During the transmission from the Siwarex MS module to the PC, the following message-window appears:

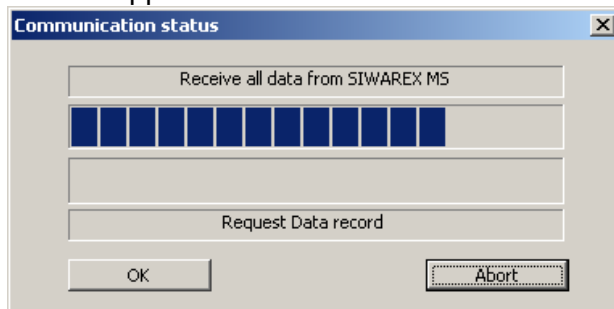

Save the data as a Siwatool MS File:

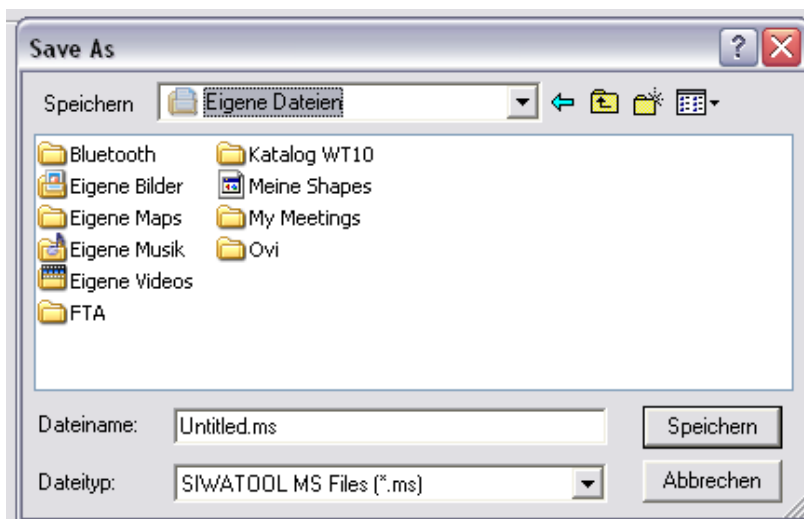
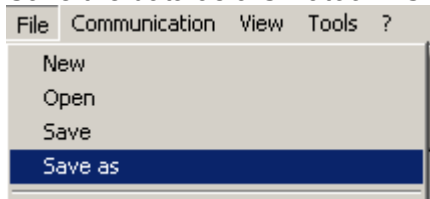

If you have any issues or suggestions regarding the related products or documents, please feel free to contact:

Technical support for SIWAREX:

Siemens AG
Industry Automation (IA)
Sensors and Communication
Process Instrumentation
D-76181 Karlsruhe
Germany

Tel: +49 721 595 2811

Fax: +49 721 595 2901

E-mail: siwarex.hotline.aud@siemens.com

Website: www.siemens.com/siwarex

Copyright Statement

All rights reserved by Siemens AG

This document is subject to change without notice. Under no circumstances shall the content of this document be construed as an express or implied promise, guarantee (for any method, product or equipment) or implication by or from Siemens AG. Partial or full replication or translation of this document without written permission from Siemens AG is illegal.