

UMV 2301 AS

Speed controller for asynchronous motors

Installation and maintenance

Speed controller for asynchronous motors UMV 2301 AS

Ref. 2881 - 4.33 / a - 2.98

ADDENDUM

UL MARKING REQUIREMENTS

1 - UL LISTING INFORMATION

The Drive conforms to UL listing requirements only when the following are observed :

- The Drive is installed in a type 1 enclosure, or better, as defined by UL50.
- UL listed fuses class RK1 600Vac are used in the AC supply.
- Class 160/75°C (140/167°F) copper wire only is used in the installation.
- The ambient temperature does not exceed 40°C (104°F) when the Drive is operating.
- The terminal tightening torques specified in the table in Terminal sizes and tightening torques in Chapter 2 installing the Drive are used.

2 - INSTALLING THE DRIVE



- **UL listing is valid when the Drive is installed in a type 1 enclosure, or better, as defined by UL50.**

2.1 - Planning the installation

UL listing is dependent on the use of the correct type of UL listed fuse, and applies when the symmetrical short-circuit current does not exceed 5 kA for model sizes 8T to 50T, and 10 kA for model size 60T to 120T.

Model	Fuse rating
UMV 2301 AS 8T	16A
UMV 2301 AS 11T	20A
UMV 2301 AS 16T	35A
UMV 2301 AS 22T	40A
UMV 2301 AS 27T	50A
UMV 2301 AS 33T	60A
UMV 2301 AS 40T	70A
UMV 2301 AS 50T	80A
UMV 2301 AS 60T	100A
UMV 2301 AS 75T	125A
UMV 2301 AS 100T	160A
UMV 2301 AS 120T	200A

2.2 - Terminal sizes and tightening torques



- **To avoid a fire hazard and maintain validity of the UL listing, adhere to the specified tightening torques for the power and ground terminals. Refer to the following tables.**

Drive

Model	Power terminals		Ground terminals	
	Size type	Torque	Size type	Torque
UMV 2301 AS 8T to 16T	Plug-in terminal block	0.5Nm 4.4 lb.in	M4 (Torx/slot-head screw)	3N.m 26.6 lb.in
UMV 2301 AS 22T to 50T	M8 stud	25 N.m 221 lb.in	M8 stud	25 N.m 221 lb.in
UMV 2301 AS 60T to 120T	M10 stud	25 N.m 221 lb.in	M10 stud	25 N.m 221 lb.in
Torque tolerance			± 10 %	

RFI filter

Size	Part No.	Torque
A	FLT 3010	0.7 N.m 6 lb.in
B	FLT 3027	1.6 N.m 14 lb.in
C	FLT 1057	12.6 N.m 111 lb.in
D	FLT 1071	12.6 N.m 111 lb.in
E	FLT 1111	25 N.m 221 lb.in
F	FLT 1171	25 N.m 221 lb.in
Torque tolerance		± 10 %

Speed controller for asynchronous motors UMV 2301 AS

2.3 - Using the gland plate and cable glands



- When the gland plate(s) are not fitted, objects less than 60 mm (2 1/2 In) wide can pass through the cable entry opening and possibly make contact with live parts inside the Drive.

Fit the gland plate and cable glands as required.
Before fitting cable glands, push out sufficient blanking caps from the gland plate.

Note that the IP rating of the Drive is reduced if any holes in the gland plate are left open. The rating is affected as follows :

Gland plate not fitted	IP00
Gland plate fitted Unused holes uncovered	IP10
Gland plate and glands fitted Blanking caps covering unused holes	IP40

Model size	Gland plate hole diameter	
	Control signal wiring	Power cables
UMV 2301 AS 8T to 16T	20 mm 3/4 in	20mm 3/4 in
UMV 2301 AS 22T to 50T	20 mm 3/4 in	28mm 1 1/4 in
UMV 2301 AS 60T to 120T	20 mm 3/4 in	28mm 1 1/4 in

Speed controller for asynchronous motors UMV 2301 AS

NOTE

LEROY-SOMER reserves the right to modify the specifications of its products at any time in order to incorporate the latest technological developments. The information enclosed in the present document may therefore change without notice.

LEROY-SOMER gives no contractual guarantee whatsoever concerning the information published in this document and cannot be liable for any error it may contain nor for any damage arising from its use.

CAUTION

For the own safety of the user, this speed controller must be connected to an approved earth (terminal B).

If an accidental start of the installation represents a risk for personnel or the machines to be driven, it is imperative that the power supply of the drive is fitted with an isolating switch and a circuit-breaking device (power contactor) controllable through an external safety system (emergency stop, fault detector).

The speed controller is fitted with safety devices which can stop the controller in the event of faults and thus stop the motor. The motor itself can be jammed for mechanical reasons. Finally, voltage fluctuations, and particularly power cuts, can also cause the motor to switch off.

The cure of the causes of the shutdown can lead to restarting, which may be dangerous for certain machines or installations. In such cases, it is essential that the user makes appropriate arrangements against restarting after unscheduled stops of the motor.

The speed controller is designed to be able to power a motor and the driven machine above its rated speed. If the motor or the driven machine is not mechanically designed to operate at such speeds, the user risks serious injury from the resulting mechanical damage.

Before programming a high speed, it is essential that the user ensures that the system can withstand it.

The speed controller is a component designed for integration within an installation or an electrical machine : it is therefore of the responsibility of the user to make sure the system complies with current standards.

LEROY-SOMER declines all responsibility whatsoever should the above recommendations not being complied with.

.....

Manual corresponding to software version 1.1.1

For more recent software versions, refer to enclosed appendix or ask LEROY-SOMER

Speed controller for asynchronous motors UMV 2301 AS

SAFETY AND OPERATING INSTRUCTIONS CONCERNING SPEED CONTROLLERS (According to low voltage directive 73/23/CEE modified by 93/68/CEE)

 Throughout the manual, this symbol warns against consequences which may arise from inappropriate use of the speed controller, since electrical risks may lead to material or physical damage as well as constitute a fire hazard.

1 - General

According to their degree of protection, speed controllers can during operation comprise bare live parts, sometimes moving or rotating, as well as hot surfaces. Unjustified removal of protections, incorrect use, faulty installation or inappropriate operation could represent a serious risk to personnel and machinery. Refer to the manual for additional information.

Any work related to transportation, installation, commissioning and maintenance must be carried out by experienced and qualified personnel (see CEI 364 or GENELEC HD 384, or DIN VDE 0100 and national specifications for installation and accident prevention).

According to these basic safety instructions, qualified personnel means persons competent to install, mount, commission and operate the concerned product and possessing the relevant qualifications.

2 - Use

Speed controllers are components designed for integration within an installation or an electrical machine. When integrated in a machine, commissioning is forbidden as long as conformity with Directive 89/392/CEE (Machinery Directive) has not been checked. It is also necessary to comply with standard EN 60204, which especially stipulates that electrical actuators (which include speed controllers) cannot be regarded as circuit-breaking devices and by no means as isolating switches.

Commissioning can take place only if the requirements of the Electromagnetic Compatibility Directive (89/336/CEE, modified by 92/31/CEE) are fulfilled.

Speed controllers fulfil the requirements of the Low Voltage Directive 73/23/CEE, modified by 93/68/CEE. The harmonized standards of the DIN VDE 0160 series in connection with standard VDE 0660, part 500 and EN 60146/VDE 0558 are also applicable.

Technical specifications and instructions concerning connection conditions specified on the rating plate and in the supplied documentation must absolutely be respected without fail.

3 - Transportation, storage

All instructions concerning transportation, storage and correct handling must be respected.

Climatic conditions specified in the technical manual must be respected.

4 - Installation

Installation and cooling of equipment must comply with the specifications stated in the manual supplied with the product.

Speed controllers must be protected against excessive stress. More particularly, avoid any damage to parts and/or modification of insulation distances between components during transportation and handling. Avoid touching electronic components and contact parts.

Speed controllers include parts which are sensitive to electrostatic stress and can easily be damaged if handled incorrectly. Electrical components must not be exposed to mechanical damage or destruction (possible risks to health !).

5 - Electrical connection

When work is carried out on the powered-up speed controller, national specifications for accident prevention must be respected.

Electrical installation must conform with the appropriate specifications (for instance wire section, protection with circuit-breaking fuse, connection of protective conductor). Refer to the documentation for more detailed information.

Instructions for an installation complying with electromagnetic compatibility requirements (such as screening, earthing, presence of filters and correct mounting of cables and conductors) are outlined in the documentation supplied with the speed controller. These instructions must always be respected even if the speed controller has the CE mark. The manufacturer of the installation or of the machine is responsible for the conformity with the limits given in the EMC legislation.

6 - Operation

Installations incorporating speed controllers must be fitted with additional protection and monitoring equipments specified in the current relevant safety regulations, such as law on electrical equipment, specifications for accident prevention, etc... Modifications to speed controllers using control software are allowed.

After the speed controller has been powered down, active parts of the equipment and live power connections must not be touched immediately as the capacitors may still be charged. In view of this, refer to the warnings marked on the speed controllers.

During operation, all doors and protections must remain closed.

7 - Service and maintenance

Refer to the manufacturer's documentation.

This document must be passed on to the end user.

Speed controller for asynchronous motors UMV 2301 AS

FOREWORD

The present manual describes how to commission digital technology UMV 2301 AS flux vector speed controllers. It gives all details about the procedures to be carried out on the controller and informs about extension options.

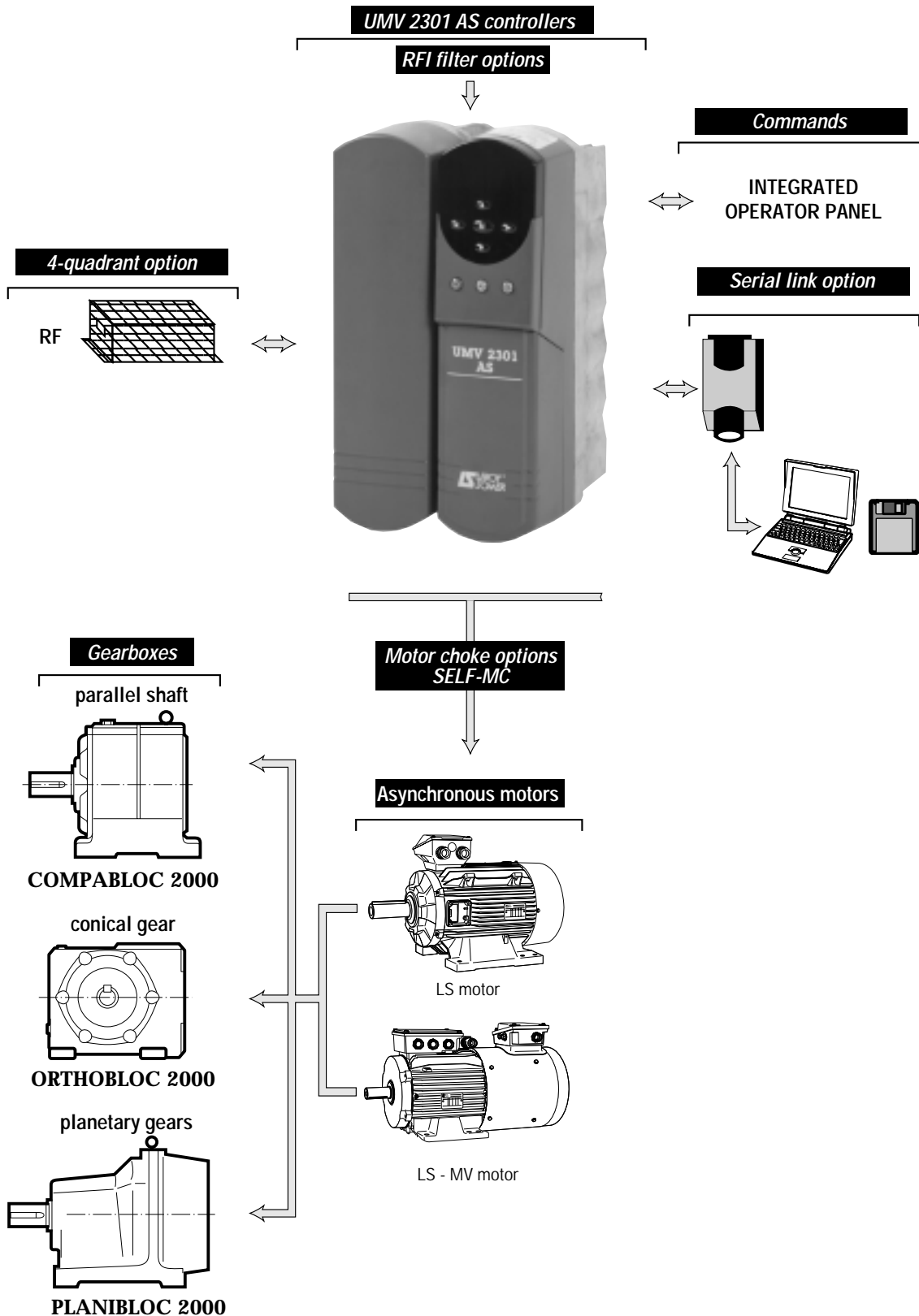

Speed controller for asynchronous motors UMV 2301 AS

CONTENTS

	Pages
1 - GENERAL INFORMATION	
1.1 - General operating principle	6 - 7
1.2 - Product designation	8
1.3 - Specifications	8 to 10
1.4 - Environmental specifications	11
1.5 - Weight and dimensions	11
2 - MECHANICAL INSTALLATION	
2.1 - Checks on receipt	12
2.2 - Installation precautions	12
2.3 - Installing the controller	12 to 15
3 - CONNECTIONS	
3.1 - Connection of asynchronous motor	16
3.2 - Connection of controller	17 to 20
3.3 - Description of cables and protections	21
3.4 - Particular connections	22
3.5 - Electrical and electromagnetic phenomena	23 to 27
3.6 - Block diagrams	28 to 34
4 - COMMISSIONING	
4.1 - Procedure for using the operator console	35 to 37
4.2 - Starting-up the controller	38 - 39
4.3 - Menu 0	40 to 50
4.4 - Fault processing	51 - 52
4.5 - Other menus.....	53 to 97
5 - FAULTS - DIAGNOSIS	
5.1 - Display of drive trip codes	98 - 99
5.2 - Display of controller status	99
5.3 - Display of controller alarms.....	99
5.4 - Logic output signals	99
6 - MAINTENANCE	
6.1 - Introduction and advice	100
6.2 - Service	100
6.3 - Voltage, current and power measurements	100
6.4 - Spare parts list	100
6.5 - Replacement of products	100
7 - OPERATING EXTENSIONS	
7.1 - Serial link option	101
7.2 - RF braking resistors	101
7.3 - RFI filters	102 - 103
7.4 - Three-phase motor chokes for attenuation of leakage current : Self-MC	103
8 - SUMMARY OF SETTINGS	105 - 106

Speed controller for asynchronous motors UMV 2301 AS

1 - GENERAL INFORMATION

1.1 - Operating principle

1.1.1 - General

The **UMV 2301 AS** is an AC power controller for asynchronous motors.

The **UMV 2301 AS** controller is fitted with an inverter bridge with IGBT transistors.

This advanced technology considerably reduces noise and temperature rise for variable speed induction motors.

Performance of the **UMV 2301 AS** controller are perfectly suitable for use in all 4 quadrants of the torque - speed diagram.

During periods of operation in generator mode, the energy restored by the motor is dissipated in resistors.

1.1.2 - Block diagram

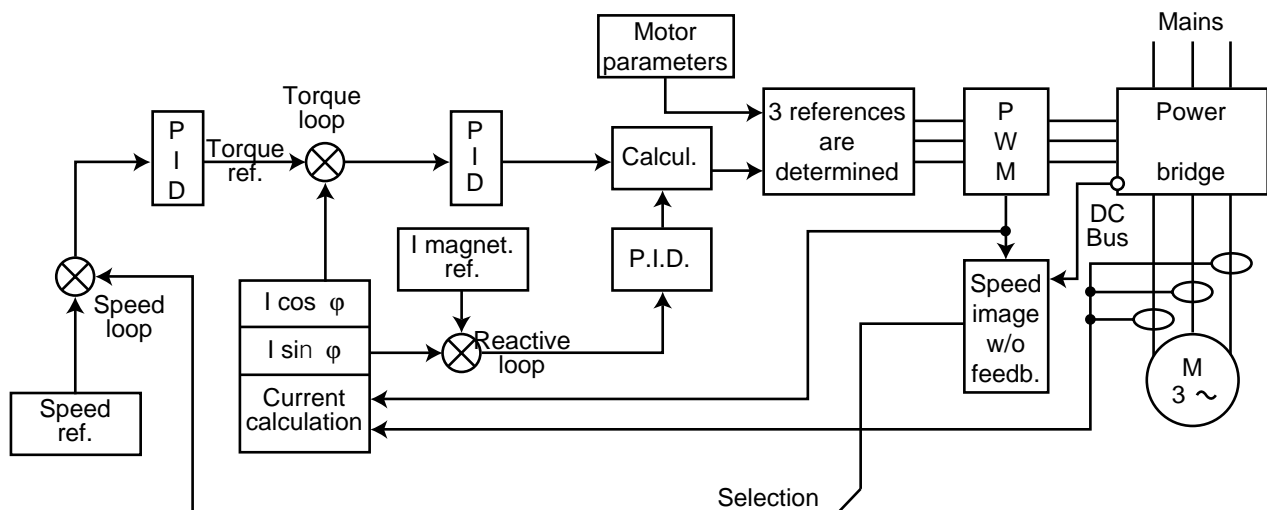

Speed controller for asynchronous motors UMV 2301 AS

1.1.3 - Organization chart of menus

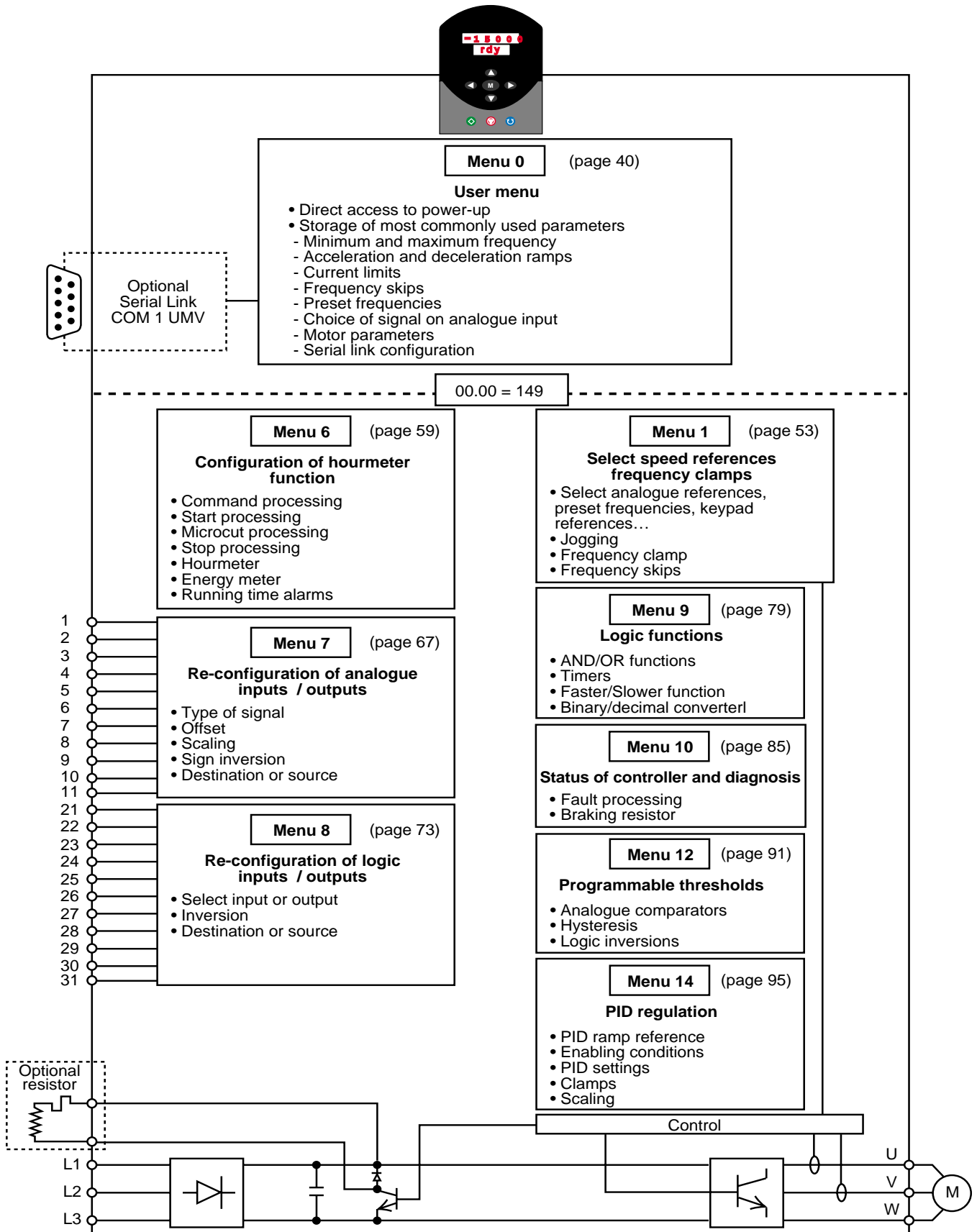

Speed controller for asynchronous motors UMV 2301 AS



1.2 - Product designation

UMV 2301 AS : open loop speed controller operating with flux vector control mode or voltage / frequency control (V to F mode).

8 = Rating in kVA at 400V,

T = 3-phase supply.

This designation appears on the nameplates located on the upper side of the controller.

Input data	Serial nr	 UMV 2301 AS 8T CT Ref : UNI 2401 VTC		Output data	Software version									
		<p>Il est indispensable de lire la notice avant de raccorder cet appareil</p> <p>Après mise hors tension, attendre 10 minutes pour toute intervention dans l'appareil</p>				<p>It is essential to read the instructions before connecting the inverter</p> <p>After switching off the inverter, wait 10 minutes before performing maintenance or inspection</p>								
		<table border="1"> <thead> <tr> <th>ENTRÉE / INPUT</th> <th colspan="2">SORTIE / OUTPUT</th> </tr> </thead> <tbody> <tr> <td>3 Ph 380/480V</td> <td>3 Ph 0-380/480 V</td> <td>4kW</td> </tr> <tr> <td>13.7 A</td> <td>12 A</td> <td>14.4A/60S</td> </tr> </tbody> </table>		ENTRÉE / INPUT	SORTIE / OUTPUT		3 Ph 380/480V	3 Ph 0-380/480 V	4kW	13.7 A	12 A	14.4A/60S		
ENTRÉE / INPUT	SORTIE / OUTPUT													
3 Ph 380/480V	3 Ph 0-380/480 V	4kW												
13.7 A	12 A	14.4A/60S												
		Date : 11/08/97 Serial N° 327310002 		SW 01.01.01 										

1.3 - Specifications

1.3.1 - Main electrical data

Power supply	3-phase supply 380V to 480V ± 10 %
Input frequency	48Hz to 62Hz
Phase unbalance of input	≤ 3 %
Output voltage	From 0V to input voltage
Maximum number of power-ups per hour	20

1.3.2 - Electrical output data

UMV 2301 AS rating	CT ref.	Data for switching frequency = 3kHz			Permanent rated current for switching frequency > 3 kHz			
		Effective motor power at 400V (kW)	Permanent rated current (A)	Overload current during 60s (A)	4,5 kHz (A)	6 kHz (A)	9 kHz (A)	12 kHz (A)
8T	UNI 2401 VTC	5,5	12	14,4	-	-	-	-
11T	UNI 2402 VTC	7,5	16	19,2	-	-	-	13
16T	UNI 2403 VTC	11	25	30	-	22	16	13
22T	UNI 3401 VTC	15	34	40,8	-	-	X	X
27T	UNI 3402 VTC	18,5	40	48	-	-	X	X
33T	UNI 3403 VTC	22	46	55,2	-	-	X	X
40T	UNI 3404 VTC	30	60	72	-	50	X	X
50T	UNI 3405 VTC	37	74	88,8	X	X	X	X
60T	UNI 4401 VTC	45	96	115	X	X	X	X
75T	UNI 4402 VTC	55	124	148	X	X	X	X
100T	UNI 4403 VTC	75	156	187	X	X	X	X
120T	UNI 4404 VTC	90	180	216	X	X	X	X

- : No derating

X : Frequency not available

Speed controller for asynchronous motors UMV 2301 AS

1.3.3 - Specifications and main functions of basic menu 0

DESCRIPTION	UMV 2301 AS 8T to 16T	UMV 2301 AS 22T to 50T	UMV 2301 AS 60T to 120T
Regulation mode	<ul style="list-style-type: none"> • Vector control, open loop • Voltage / frequency control (U/F) 		
Regulation	<ul style="list-style-type: none"> • Speed reference 		
Constant torque Constant power	Adjusted by basic frequency		
Switching frequency	3 - 4,5 - 6 - 9 and 12 kHz	3 - 4,5 - 6 kHz	3 kHz
Overload capacity	<ul style="list-style-type: none"> • 120 % of controller rated current during 60s 		
Braking	<ul style="list-style-type: none"> • Hypersynchronous. Controller alone or with RF options • Through DC injection 		
CONTROL			
Control logic	<ul style="list-style-type: none"> • Negative { high level > + 15V • Positive { low level < + 5V 		
Speed references	<ul style="list-style-type: none"> • Analogue : <ul style="list-style-type: none"> - differential voltage $\pm 10V$ (input impedance : 100 KΩ) - voltage $0/\pm 10V$ in common mode (input impedance : 100 KΩ) - current 0-20mA, 4-20mA or 20-0mA, 20-4mA • Digital : <ul style="list-style-type: none"> - from keypad - by pulses whilst running 		
Forward / reverse command	<ul style="list-style-type: none"> • Through inversion of reference polarity • Through logic inputs • From operator console 		
Controller / motor self-adaptation	Measurement of motor data (cos ϕ , magnetizing current and statoric resistances).		
FUNCTION			
Acceleration / deceleration ramps	Separate settings from 0 to 3200s. Linear or " S " curve. Radius of " S " ramp can be adjusted.		
Minimum/maximum speed limitation	Speed variation between 2 stops.		
Stop mode	<ul style="list-style-type: none"> • Coast stop : through logic input (terminal 30) instantaneous cut-out of motor power supply. • Ramp stop (following different modes). • DC injection braking stop. 		
Select dynamic V to F mode	Automatic adaptation of V/F curve to motor load in V to F mode.		
Catch spinning motor	Possibility to start the controller whilst the motor is running.		

Speed controller for asynchronous motors UMV 2301 AS

TRIPS	UMV 2301 AS 8T to 16T	UMV 2301 AS 22T to 50T	UMV 2301 AS 60T to 120T
Central unit failure	Fault internal to controller and options		
External trip	Fault forced through terminal block (terminal 30).		
Overload (I x t)	Electronic thermal relay for motor and braking resistor.		
Overheating	<ul style="list-style-type: none"> • Controller : radiator and electronic cards. • Motor : with PTC probe : - trip for PTC > 3 kΩ, - reset for PTC \leq 1,65 kΩ, - PTC detection in short-circuit, (\leq 4 Ω in TH SC mode) with PTO probe. 		
Overcurrent	200 % of rated current. Short-circuit : phase-phase/phase-earth.		
Phase loss Phase imbalance	Mains power cut.		
Under- and overvoltage, DC bus	DC bus voltage out of its normal operating range.		
Internal power supply	Monitoring of controller internal power supplies.		
INDICATIONS			
Display	On operator console: - Output frequency (Hz) or motor speed (min ⁻¹), - Output current (A).		
Relay	Relay 250 VAC - 5A (resisting charge)		
Logic output	Commutator open : external source from 0 to +24V 100 mA Active : - open loop : at speed, - closed loop : zero speed.		
Analogue output	- 0 to \pm 10V 10mA		
OPTIONS			
Filters for attenuation of radio interferences	FLT - 3027	FLT - 1051 - 1071 - 1111	FLT - 1111 - 1171
Motor chokes for attenuation of leakage current	Self MC 5,5T, 11T and 27T	Self MC 27T and 50T	Self MC 75T and 120T
Communication option	Integrated in the UMV 2301 AS - serial link RS 485 and RS 232, protocole ANSI x 3.28 : COM 1 UMV		
Resistor braking RF	RF 320T to RF 5500T	RF 320T to RF 18500T	RF 320T to RF 55000T

Speed controller for asynchronous motors UMV 2301 AS

1.4 - Environmental specifications

- ⚠ • Protection index of UMV 2301 AS controllers is IP 40.
- They are designed for installation in a cubicle or a chest in order to protect them against dust and condensation. Access of non-qualified personnel should be prohibited.

1.4.1 - General

Specifications	Level
Chest protection	IP40
Storage temperature	- 40 °C to + 50 °C, maximum 12 months.
Operating temperature	- 5 °C to + 40 °C.
Altitude	• ≤ 1000 m without derating. • Derating : 1 % of I _n per 100 m above 1000m up to 4000m maximum.
Humidity	Without condensation.
Vibration	According to CEI 68-2-34
Shocks	According to CEI 68-2-27
Immunity	According to : - CEI 801-2 Level 3 - CEI 801-3 Level 3 - CEI 801-4 Level 3 (power), Level 4 (control)
Emissions	conducted According to : - EN 50081-1 (VDE 875 N) with : switching frequency 3 kHz and filter for UMV 4301 1.5T to 16T - EN 50081-2 (VDE 875 G) UMV 4301 from 1.5T to 120T radiated According to EN 50081-2

1.4.2 - Loss tables (W)

Switching frequency	UMV 2301 AS											
	8T	11T	16T	22T	27T	33T	40T	50T	60T	70T	100T	120T
3 kHz	190	250	390	550	640	700	920	1120	1430	1860	2320	2600
4,5 kHz	↓	↓	↓	↓	↓	↓	x	x	x	x	x	x
6 kHz	↓	↓	410	770	800	860	x	x	x	x	x	x
9 kHz	↓	320	x	x	x	x	x	x	x	x	x	x
12 kHz	300	x	x	x	x	x	x	x	x	x	x	x

1.4.3 - Table over forced ventilation flow rate (m³ h)

Forced ventilation	UMV 2301 AS											
	8T	11T	16T	22T	27T	33T	40T	50T	60T	70T	100T	120T
Flow (m ³ h)	85			320					640			

1.5 - Weight and dimensions

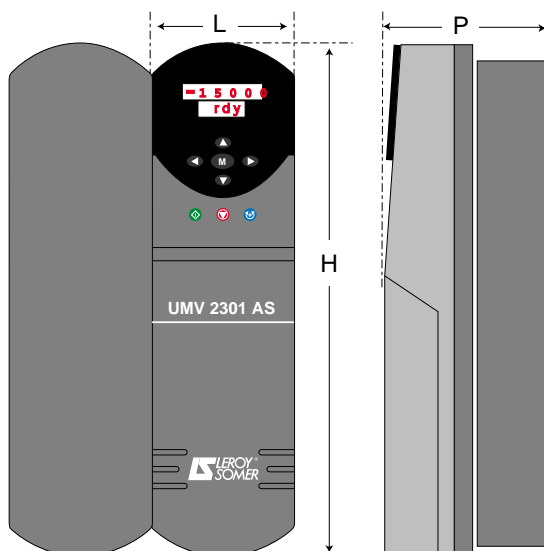

Rating	Dimensions (mm)			Weight (kg)
	H	L	P	
UMV 2301 AS				
8T to 16T	335	190	200	8
22T to 50T	335	375	260	22
60T to 120T	700	500	260	70

Speed controllers for asynchronous motors

UMV 2301 AS

2 - MECHANICAL INSTALLATION



• The owner or user is responsible for making sure that installation, operation and service of the controller and its options comply with legislation relating to the safety of machinery and personnel, and with current regulations of the concerned country.

• UMV 2301 AS controllers must be installed in an environment free from conducting dust, fumes, corrosive fluids and gases and from condensation (for instance class 2 according to UL 840 and CEI 664.1). The controller must not be installed in a hazardous area unless it is enclosed in a specially adapted cubicle. In this case the installation must be certified.

• Within atmospheres subject to condensation, it is necessary to install a heating system which functions when the controller is not in use and is disconnected when the controller is operating. Ideally this heating system should be controlled automatically.

• The housing of the UMV 2301 AS controller is not fireproof : therefore it might be necessary to use a fireproof cubicle.

• The UMV 2301 AS rating more than 22T weigh more than 22 kg. They should be handled using adapted means.

2.1 - Checks on receipt

Before installing the controller, make sure that :

- the controller has not been damaged during transport,
- all mounting accessories are included,
- the nameplate is corresponding to the power supply and motor specifications.

2.2 - Installation precautions

The controller should be mounted upright with a clearance of 100 mm over and under.

Do not mount the UMV 4301 controller over a heat source or another controller. There is a risk for tripping when the radiator temperature reaches 90°C. Never obstruct the ventilation louvres.

The UMV 2301 AS 60T to 120T controllers are supplied with 2 M10 tapped holes for fitting shackles.

2.3 - Installation of the controller

2.3.1 - General

There are 2 different ways to install the controller : heat sink inside or outside of cubicle. With the latter configuration it is not necessary to dissipate the controller losses.

- UMV 2301 AS from 8T to 16T

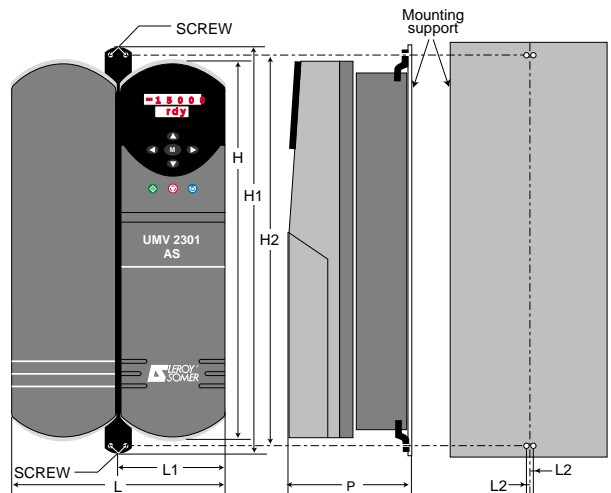

Speed controllers for asynchronous motors UMV 2301 AS

- UMV 2301 AS from 22T to 50T

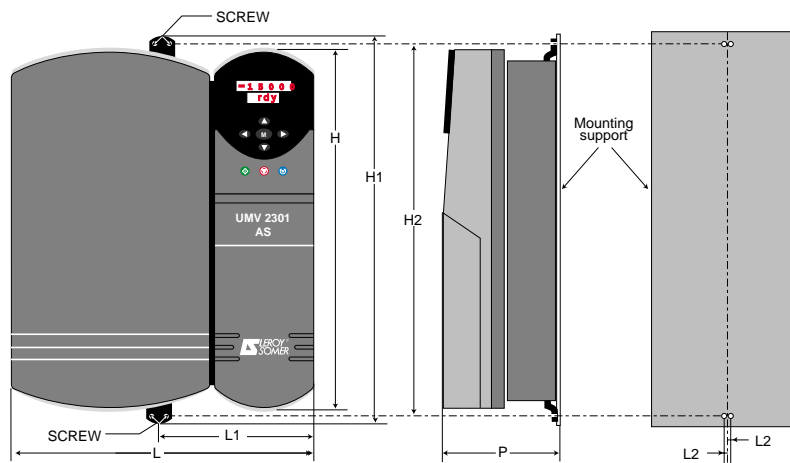

- UMV 2301 AS from 60T to 120T

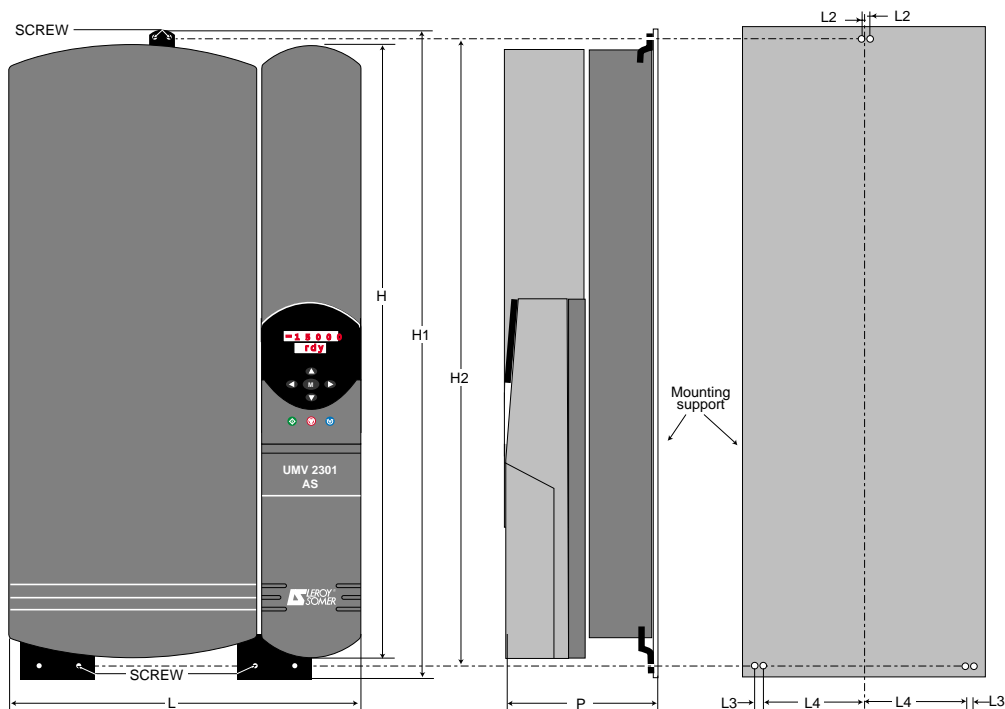

Dimensions

UMV 2301 AS rating	Dimensions (mm)									
	H	H1	H2	L	L1	L2	L3	L4	P	VIS
8T to 16T	335	368	345	190	95	16,5	-	-	200	M6
22T to 50T	335	368	345	375	187,5	16,5	-	-	260	M6
60T to 120T	700	743	717,5	500	250	-	65	143,5	260	M6

2.3.2 - Mounting with heat sink inside the cubicle

The UMV 2301 AS 8T to 16T controllers must absolutely be mounted on a massive base plate in order to direct the cooling air flow efficiently : otherwise, 20 % derating is necessary.

The UMV 2301 AS controllers 22T to 120T can also be mounted on a grille, a frame or a DIN rail support.

- Insert the mounting lugs into the grooves on top and under the heat sink,
- Fasten the lugs onto the base plate, the DIN rail support or the grille with M6 screws.

Speed controllers for asynchronous motors UMV 2301 AS

2.3.3 - Mounting with heat sink outside of cubicle

- 1 - Cut out and drill the rear panel of the cubicle.
- 2 - Insert a mounting lug into the groove on top of controller.
- 3 - For the **UMV 2301 AS** controllers rating 22T to 50T and 60T to 120T, remove the lower terminal block cover in order to get access to the mounting holes.

- 4 - Set on the frame the gasket supplied with the controller.
- 5 - Insert the controller in the cut-out of the rear panel.
- 6 - Fasten the controller through the upper mountings and the lower holes.

WARNING :

Make sure that the air flow beyond the cubicle is sufficient.

- Cut-out drawings

UMV 2301 AS from 8T to 16T

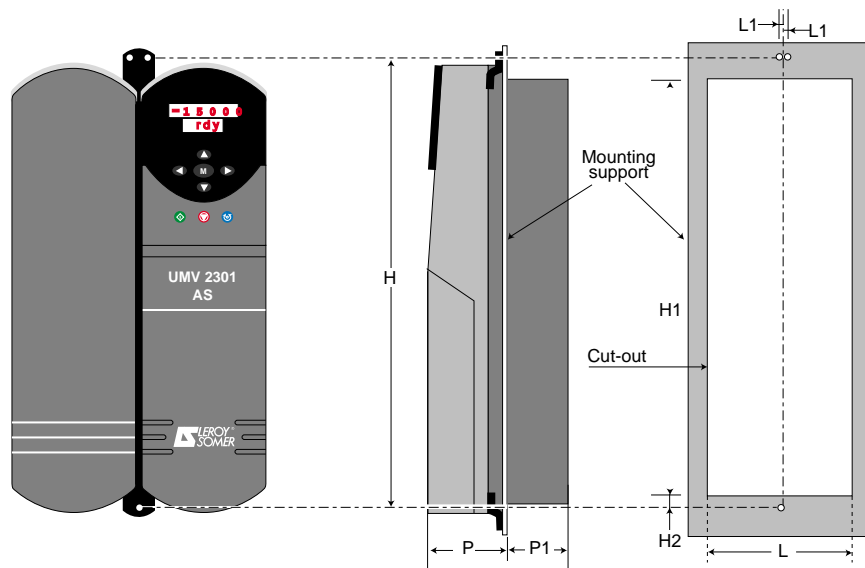

UMV 2301 AS from 22T to 50T

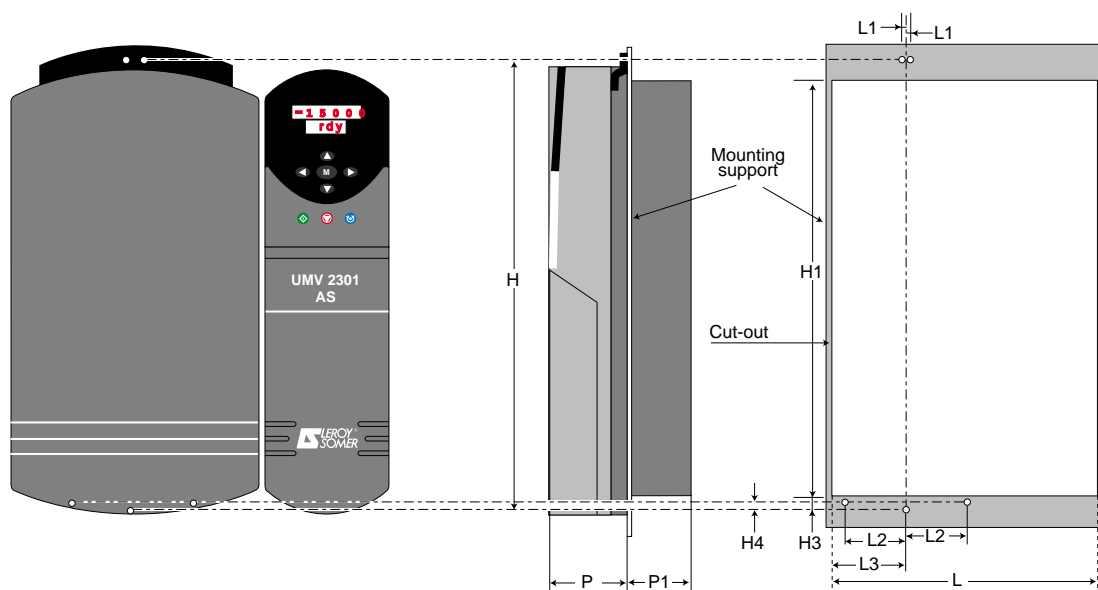

Speed controllers for asynchronous motors UMV 2301 AS

- Cut-out drawings (continued)
UMV 2301 AS from 60T to 120T

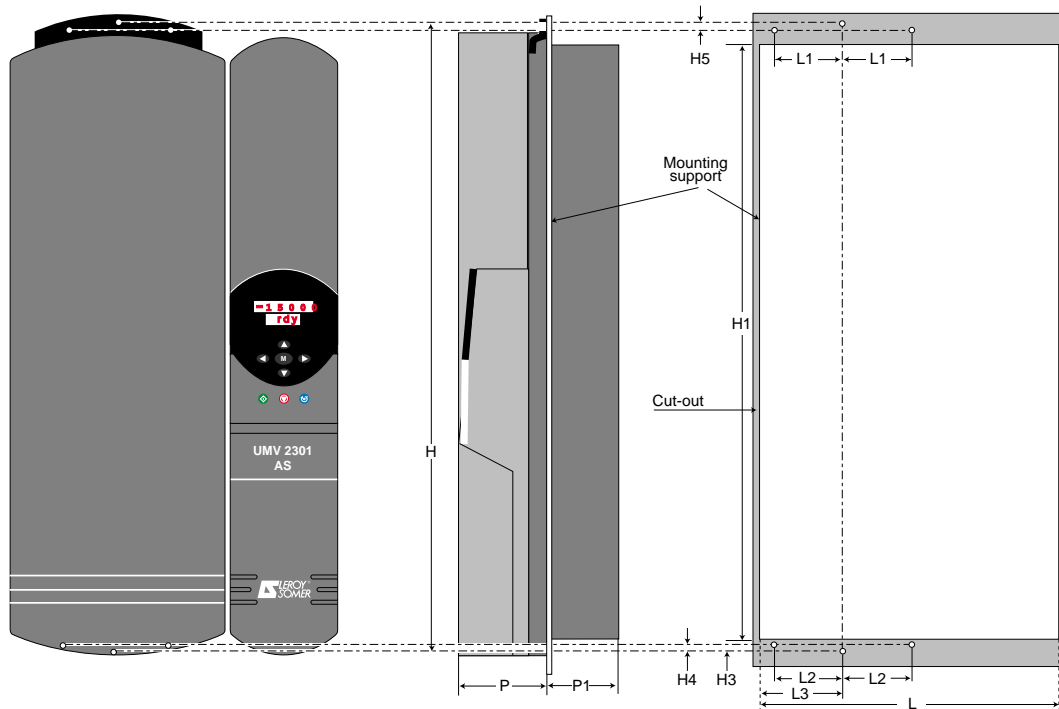

Dimensions (mm)

UMV 2301 AS rating	Dimensions (mm)												
	H	H1	H2	H3	H4	H5	L	L1	L3	L2	P*	P1**	VIS
8T to 16T	345	295	12,5	-	-	-	182	-	-	-	120	80	M6
22T to 50T	345	287	-	16	7	-	358	16,5	131,5	69	120	140	M6
60T to 120T	717,5	650	-	17	7,5	3,5	482	65	192	130	120	140	M6

* Add thickness of gasket.

** Deduct thickness of gasket.

Speed controllers for asynchronous motors UMV 2301 AS

3 - CONNECTIONS

⚠ • All connection works must be carried out according to the current legislation of the concerned country. This includes earthing or grounding in order to make sure that no directly accessible part of the controller can remain at mains potential or any other voltage that may be hazardous.

• The voltages existing on the wires or connections to the mains, the motor, the braking resistor or the filter, may cause fatal electric shocks. Avoid contact in any case.

• The controller must be supplied through a circuit-breaking device in order to disconnect it safely.

• The controller power supply must be protected against overloads and short-circuits.

• The stop function of the controller does not protect against the high voltages existing on the terminal blocks.

• The controller contains capacitors which remain charged at a fatal voltage even after the power supply has been cut off.

• After the power supply has been cut off, wait for 10mn before removing protective cover.

• Make sure that voltage of DC bus is lower than 40V before any work is carried out.

• Check that voltage and current of controller, motor and mains are compatible.

3.1 - Connection of induction motor

3.1.1 - Terminal block

The LS MV motors are mainly dual-voltage motors, 230/400V. As standard, star-connection should thus be used.

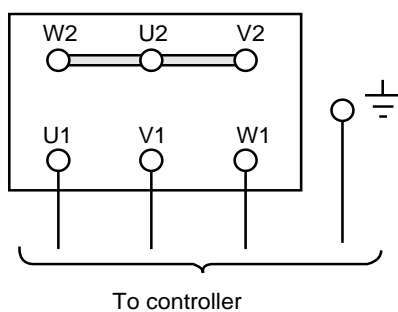

Nevertheless, check the nameplate before connecting the motor.

3.1.2 - Auxiliary terminal blocks

3.1.2.1 - Optional forced ventilation

LS MV motors can be fitted with an optional forced ventilation as follows :

• Motor LS MV with frame size ≤ 132 , single-phase power supply as standard :

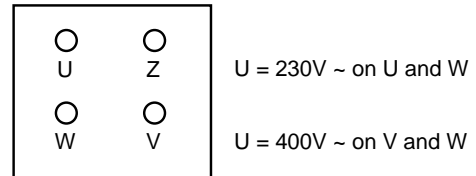

• Motor LS MV with frame size ≥ 160

Forced ventilation power supply

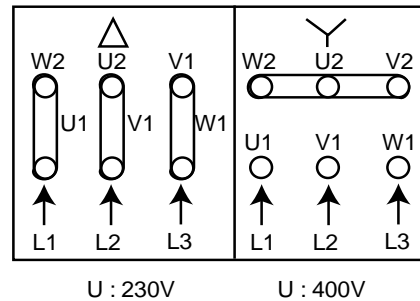

Refer to LS MV motor catalogue for further information.

Speed controllers for asynchronous motors UMV 2301 AS

3.2 - Connection of controller

3.2.1 - Power terminal block

3.2.1.1 - Access to power terminal blocks

- UMV 2301 AS 8T to 16T

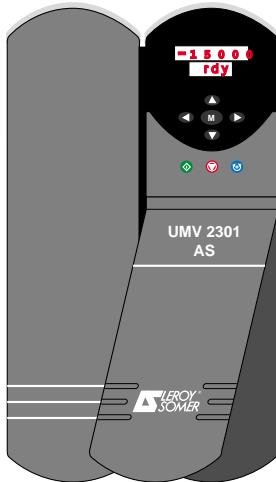

Remove the plastic cover on control side by slightly parting both lower edges.

- UMV 2301 AS 22T to 120T

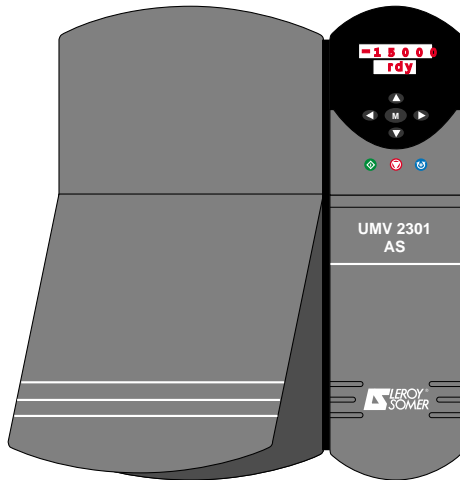

Remove the plastic cover on control side by slightly parting both lower edges.

3.2.1.2 - Wiring of power terminal block

- UMV 2301 AS 8T to 16T

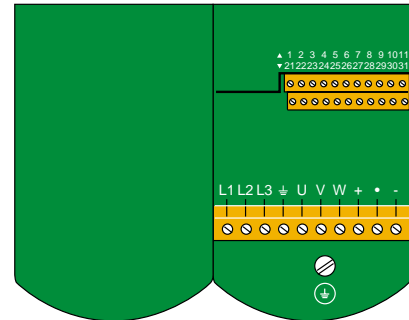

Tightening torque of power terminal blocks : 0,5 Nm.

- UMV 2301 AS 22T to 120T

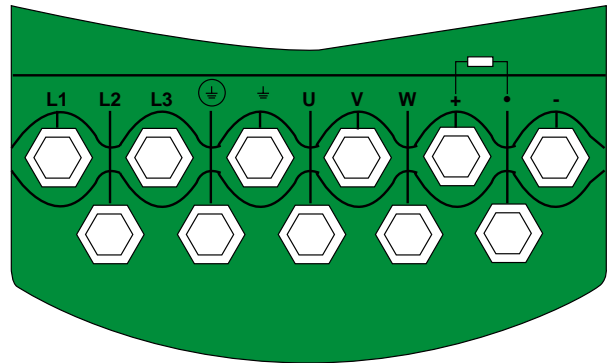

Tightening torque of power terminal blocks : 25 Nm.

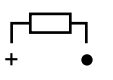
Reference	Function
L1 - L2 - L3	Controller 3-phase power supply.
B	Earth of controller and motor.
U - V - W	Connection of motor (follow the order of motor and controller phases).
	Connection of optional braking resistors R-FMV through a thermal relay. (+) access to + pole of DC bus.
-	- pole of DC bus.



Never connect the resistance directly between terminals + and -.

Speed controllers for asynchronous motors UMV 2301 AS

3.2.2 - Control terminal blocks



- Factory setting of the UMV 2301 AS controller is negative logic.
- All explanations concerning the terminal blocks refer to negative logic.
- Connecting a controller with negative logic configuration to an automat operating with positive logic configuration will cause the controller to start when powered up.

The control terminal block consist of 2 removable 11-pin connectors, accessible after removal of the control module plastic cover.

3.2.2.1 - Upper connector

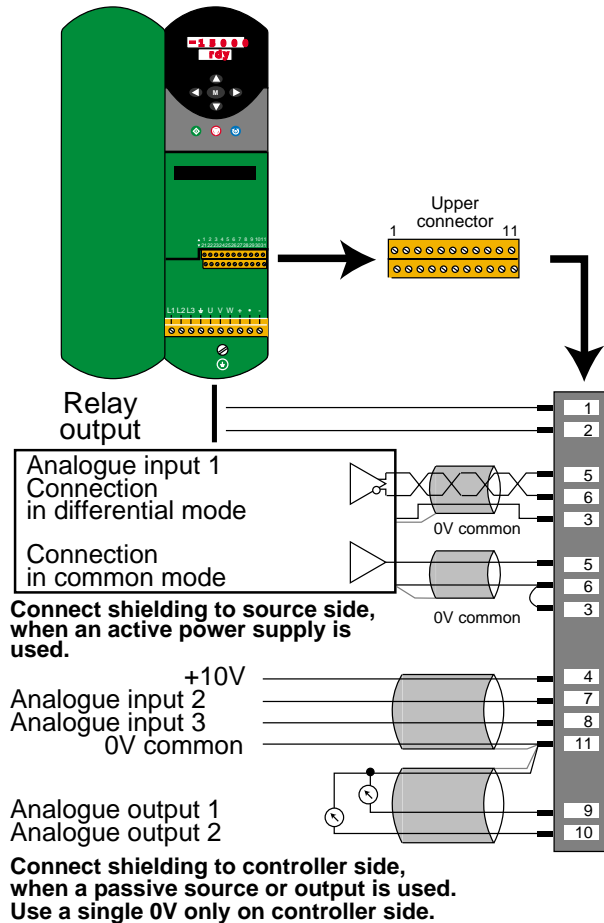

1	Programmable relay output	
2		
Specifications	250VAC maxi 5A resisting charge	
Insulation voltage	3 kV	
Reset period	8ms	
Factory configuration	Trip relay status	
	— : No voltage or fault	
	— : Controller running	

3	0V Common
----------	-----------

4	+10V analogue internal source	
Tolerance	±1 %	
Rated current	10 mA	
Protection	Overload and overheating	

5	Analogue input 1 (+)	assignable
6	Analogue input 1 (-)	
Specifications	Differential bipolar inputs (common mode operation : connect terminals 6 and 3)	
Rated voltage	± 10VDC	
Maximum voltage	± 24V/0V ± 24V differential	
Input impedance	100 kΩ	
Resolution	12 bits plus sign	
Sampling	≤ 2ms	
Factory configuration	0 - 10V : Speed input 1 0V : minimum speed 10V : maximum speed	

7	Programmable analogue input 2	
Specifications	Common bipolar mode	
Rated voltage	± 10VDC	
Maximum voltage	± 24VDC/0V	
Input impedance	100 kΩ	
Resolution	10 bits plus sign	
Sampling	≤ 2ms	
Factory configuration	0 - 10V : Speed input 2 0V : minimum speed 10V : maximum speed	

Speed controllers for asynchronous motors UMV 2301 AS

8 Programmable analogue input 3	
Specifications	Common bipolar mode
Rated voltage	± 10VDC
Maximum voltage	± 24VDC/0V
Input impedance	100 kΩ
Resolution	10 bits plus sign
Sampling	≤ 2ms
Factory configuration	Control of PTC or PTO probe
	Internal voltage : 4,25V
	Trip threshold : 3kΩ Deletion threshold : 1,65kΩ

9 Programmable analogue output 1	
10 Programmable analogue output 2	
Specifications	Common bipolar voltage mode
Voltage output or current output	± 10VDC, 10mA maxi 0-20mA, 4-20mA
Charge resistor	1 kΩ minimum
Protection	Court circuit
Resolution	10 bits plus sign
Sampling	≤ 2ms
Factory configuration	0 - 10V : Speed image
	1 0V : 0 10V : maximum speed
	0 - 10V : Torque image
2 0V : 0 10V : maximum torque	

11	0V common
-----------	-----------

Speed controllers for asynchronous motors UMV 2301 AS

3.2.2.2 - Lower connector

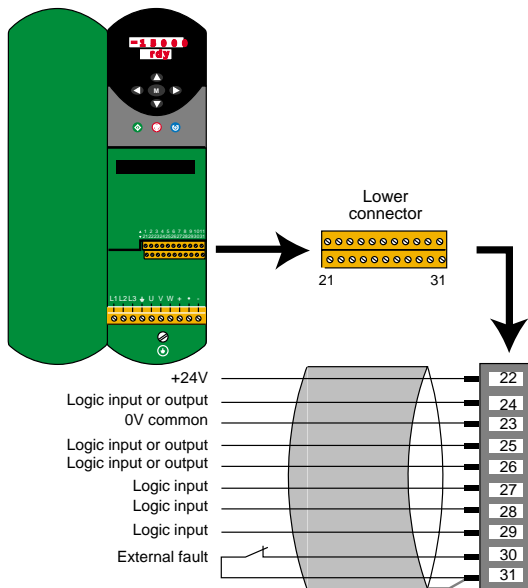

21	Earth - Do not use	
----	---------------------------	--

22	+24V internal source for logic circuit	
Tolerance	± 10 %	
Rated current	200 mA	
Overload current	240 mA	
Protection	Limitation over 240mA	

23	0V common - digital circuits only	
----	-----------------------------------	--

24	Programmable logic Inputs or Outputs	
25		
26		

Negative logic input	
Voltage	0V to +24V
Absolute max voltage	-3V to +30V
Input current with +24V	≥ 3,2mA
Logic levels	Level 0 > +15V (open circuit) Level 1 < +5V (closed circuit)

or positive logic input	
Voltage	0V to +24V
Absolute max voltage	-3V to +30V
Input current with +24V	≥ 3,2mA
Logic levels	Level 0 < +5V (open circuit) Level 1 > +15V (closed circuit)

or logic output	
Specifications	Commutator transistor open (push-pull)
Voltage	0V à +24V
Maximum output current	100mA
Overload current	120mA

Factory setting	
24	Logic output At frequency
25	Negative logic input Trip deletion
26	Negative logic input Select FP1/FP2

27	Programmable logic Inputs
28	
29	

Negative logic input	
Voltage	0V to +24V
Absolute max voltage	-3V to +30V
Input current with +24V	≥ 3,2mA
Logic levels	Level 0 > +15V (open circuit) Level 1 < +5V (closed circuit)

or positive logic input	
Voltage	0V to +24V
Absolute max voltage	-3V to +30V
Input current with +24V	≥ 3,2mA
Logic levels	Level 0 < +5V (open circuit) Level 1 > +15V (closed circuit)

Factory setting	
27	Negative logic input Forward / Stop
28	Negative logic input Reverse / stop
29	Negative logic input Select analogue input 1 (open) Select preset speeds (closed)

30	ENegative logic input - external fault
----	---

31	0V common - digital circuits only
----	-----------------------------------

WARNING :

- Negative and positive logic :
- configuration of controller is negative logic,
- connections described in § 3.6 refer to negative logic.

Speed controllers for asynchronous motors UMV 2301 AS

3.3 - Description of cables and protections



• The user is responsible for connecting and protecting the UMV 2301 AS controller according to current legislation and regulations of the concerned country. This is particularly important for the size of cables, the type and size of fuses, the connection to earth or ground, the power cut-out, the fault clearance, the insulation and protection against overcurrent.

• These tables are given as an indication, and can by no means serve as a substitute for current standards.

Rating	Motor rating (kW)	Current			Fuses		Section of power cables * * *			
		motor *	mains (A)	DC * * bus (A)	mains (A)	DC * * bus * (A)	(mm ²)			
							motor	mains	DC * * bus	B
8T	5,5	12	13,7	11,9	16	16	2,5	2,5	2,5	1
11T	7,5	16	16,8	15,7	20	25	4	4	4	2,5
16T	11	25	27	22	32	32	6	6	6	4
22T	15	34	34	30	40	40	10	10	10	10
27T	18,5	40	39	37	50	50	10	10	10	10
33T	22	46	49	44	63	63	10	10	10	16
40T	30	60	59	60	80	80	16	16	16	16
50T	37	74	74	74	80	100	16	16	16	16
60T	45	96	96	90	100	125	25	25	25	16
75T	55	124	120	110	125	160	35	35	35	16
100T	75	156	151	150	160	200	70	70	70	35
120T	90	180	173	180	200	250	70	70	70	35

* For switching frequency = 3 kHz, refer to § 1.3.2 for other frequencies.

* * In case of parallel coupling of controllers through the DC bus § 3.5.5.2.

* * * The recommended sections are valid for electric cubicles and do not take into account the line losses due to the length.

Note : the value of the mains current is a typical value depending on the source impedance. The higher the impedance, the lower the current.

Speed controllers for asynchronous motors UMV 2301 AS

3.4 - Particular connections

3.4.1 - Parallel coupling of motors in V to F mode

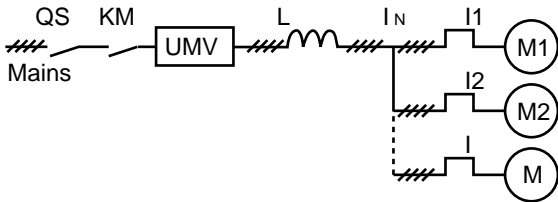

It is possible to drive several motors with different powers from one single controller. Each motor must be protected with a thermal relay.

Determination of controller rating :

$$I_N \text{ controller} > I_1 + I_2 + \dots + I$$

The specific inductance L depends on the controller rating and the total cable length to the motors. Ask LEROY-SOMER.

3.4.2 - Direct connection of the motor to the mains (by-pass) in V to F mode.

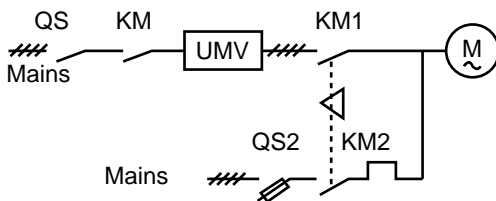

Sequence to be followed :

- KM1 must be operated before KM,
- mechanical locking between KM1 and KM2.

Time T2 = 1,5s must absolutely be respected. It corresponds to motor demagnetizing time.

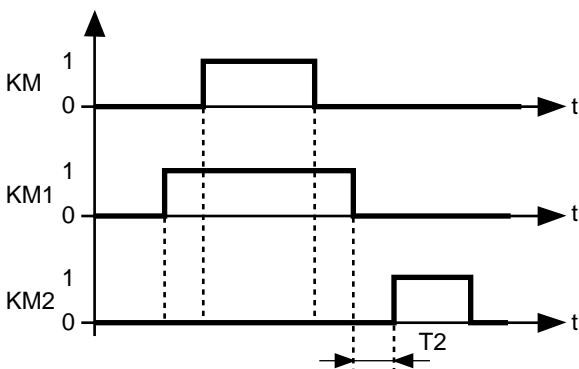

3.4.3 - Opening of switch with motor stopped

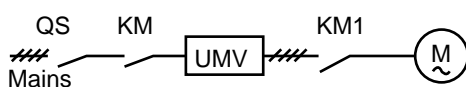

Sequence to be followed :

- start order must be given once KM1 has been operated.

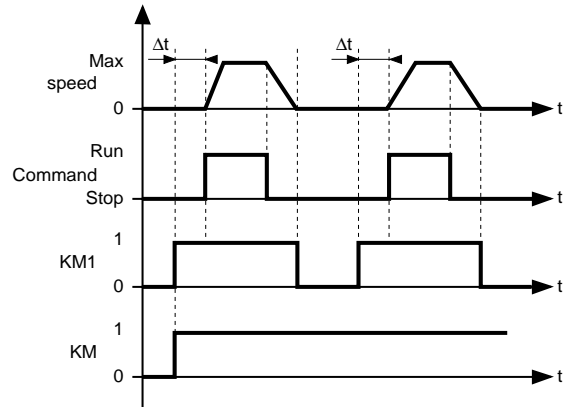

3.4.4 - Connection of earth terminals of several controllers

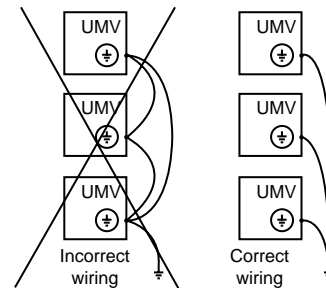

3.4.5 - Parallel coupling of controllers through the DC bus

3.4.5.1 - General

Parallel coupled controllers must have **same rating** and must be powered-up simultaneously.

The DC bus of each modulator must be fitted with fuses. (Voir § 3.4).

It is thus possible to avoid the use or to limit the number of optional braking resistors in the event of the driving energy being higher than the restored energy.

3.4.5.2 - Example : connection diagram of two UMV 2301 AS controllers

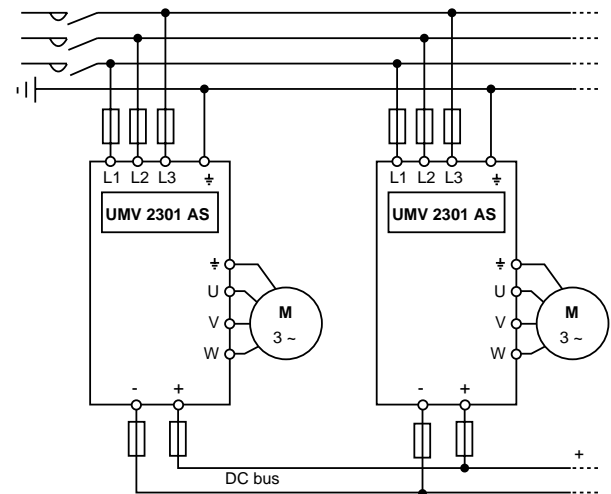

Speed controllers for asynchronous motors UMV 2301 AS

3.5 - Electrical and electromagnetic phenomena

3.5.1 - General

The power structure of speed controllers leads to the occurrence of two types of phenomena :

- low frequency harmonic feedback on the mains power supply,

3.5.2 - Low frequency harmonics

3.5.2.1 - General

The rectifier at the head of the speed controller, generates a non-sinusoidal AC line current.

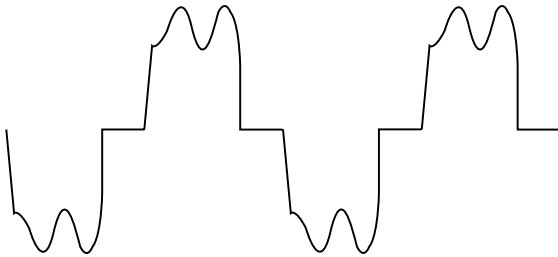

Three-phase rectifier line current consumption

This current carries harmonics with order $6n \pm 1$.

Their amplitudes depend on the impedance of the mains supply before the rectifier bridge, and on the structure of the DC bus after the rectifier bridge.

The more inductive the mains supply and the DC bus, the more these harmonics are reduced

They have a significant effect only for loads on frequency inverters of several hundred kVA and when these loads represent more than a quarter of the total on-site load.

They have virtually no effect on the electrical energy consumption level. Temperature rises associated with these harmonics in transformers and motors connected to the mains supply are negligible.

These low frequency harmonics only rarely cause interference on sensitive equipment.

3.5.3 - Radio-frequency interference : Immunity

3.5.3.1 - General

The immunity level of an equipment is defined by its ability to operate in an environment polluted by external elements or by its own electrical connections.

- emission of radio-frequency signals (RFI).

These phenomena are independant. Their consequences on the electrical environment are different.

3.5.2.2 - Standards

There is no standard for current harmonics.

Current harmonics generate voltage harmonics on the mains supply. **The amplitude of these harmonics depends on the impedance of the mains supply.**

The energy distributor, who is affected by these phenomena in the case of high **high power intallations**, has his own **recommendations** concerning the level of the voltage harmonics :

- 0,6 % on even order harmonics,
- 1 % on uneven order harmonics,
- 1,6 % on overall harmonic distortionl.

This applies to the power distribution connection and not to the harmonic generator.

3.5.2.3 - Reduction of harmonics fed back to the mains supply

The controller is fitted as standard with an inductance coil within the DC bus. The purpose is to reduce the level of harmonics fed back to the mains supply. It is therefore virtually never necessary to use any other device.

However, for some rare cases where the mains specifications and the total load on the controller make it impossible to comply with the harmonic level recommended by the energy distributor, LEROY-SOMER will offer any assistance to the installer for the determination of an additional mains choke.

3.5.3.2 - Standards

Each piece of equipment must undergo a series of standardized tests (European Standards) and meet a minimum level requirement in order to be declared in conformity with generic industrial (EN 50082-2) and domestic (EN 50082-1) standards.

3.5.3.3 - Recommendations

An installation exclusively made up of equipments complying with the standards related to immunity runs very little risk of interference.

Speed controllers for asynchronous motors UMV 2301 AS

3.5.4 - Radio-frequency interference : Emission

3.5.4.1 - General

Speed controllers use high-speed switches (transistors, semi-conductors) for switching high voltages (about 550V) and important high frequency currents (several kHz). This provides a better efficiency and a low motor noise level.

Therefore they generate radio frequency signals which may disturb operation of other equipment or distort sensor measurements :

- due to high frequency leakage currents escaping to earth via the controller / motor connection leakage capacitor and from the motor leakage capacitor through the metal structures supporting the motor.

- by conduction or feedback of radio frequency signals on the power supply cable : **conducted emissions**,

- by direct radiation close to the power supply cable or the controller / motor connection : **radiated emissions**.

These phenomena are of direct interest to the user.

The concerned frequency range (radio-frequency) does not affect the energy distributor.

3.5.4.2 - Standards

The maximum emission level is specified in the generic industrial (EN 50081-2) and domestic (EN 50081-1) standards.

3.5.4.3 - Recommendations

• **Experience shows that the levels specified in standards EN 50081-1 and 50081-2 do not necessarily need to be respected to eliminate interference.**

• **Following the elementary precautions described in the next paragraph generally results in correct operation of the installation.**

3.5.5 - Elementary precautions

These are to be taken into account during the design stage and also when wiring the cubicle and the external elements. In each paragraph, they are listed in decreasing order of influence on correct operation of the installation.

3.5.5.1 - Design

1) Choice of equipment

Give priority to components whose immunity level conforms to the generic immunity standards EN 50082-1 and EN 50082-2, and mount them in a steel cubicle.

2) Location of controller

Install the controller as near to the motor as possible in order to reduce cable length.

3.5.5.2 - Installation of controller and relevant components into the cubicle

1) Screw the controller and its components onto a metal grille or a base plate which is unpainted or paint-free around the fastening points.

2) Fasten the plate at several paint-free points on the bottom of the cubicle.

3.5.5.3 - Wiring inside the cubicle

1) Do not place the control and power cables inside the same cable duct (minimum distance 0,5m).

2) For control cables, use twisted shielded cables with tight copper shielding mesh and connect the shielding to 0V only at controller end.

3) Relays and contactors which are electrically connected to the controller should be fitted with an RC filter.

3.5.5.4 - Wiring outside the cubicle

1) Separate power cables from control cables.

2) Connect directly motor and controller earth terminals.

3) Place the motor power supply cables, as well as the auxiliary cable connecting motor and controller earth terminals, into a metallic cable duct. This cable duct should be mechanically linked to the cubicle and to the metallic structure which supports the motor. The cables should be forced to the bottom of the duct.

4) Do not route control cables (controller and feedbacks) along metallic structures which could be common with the motor support.

5) Isolate sensitive components (probes, sensors...) from metallic structures which could be common with the motor support.

3.5.5.5 - Importance of ground wiring

The immunity and radio frequency emission level are directly depending on the quality of the ground connections. All metallic grounds should be mechanically connected to each other with the greatest possible electrical contact area. By no means should the ground connections designed to ensure protection of personnel (by connecting metallic grounds to earth with a cable) serve as a substitute for ground connections.

Speed controllers for asynchronous motors

UMV 2301 AS

3.5.6 - Additional precautions

Respecting the basic precautions described in the previous paragraph generally ensures correct operation of the installation. However, its immunity could be increased by following the additional precautions below. These are listed in order of importance.

3.5.6.1 - Installation and wiring of a Self-MC choke

Most interference phenomena are caused by high frequency leakage currents escaping to earth from the controller / motor connection and from the metal structures supporting the motor.

Self-MC chokes are used to reduce these leakage currents. The longer the controller / motor cable, the more important is their role

Use the Self-MC chokes with a standard cable not exceeding 100m.

Install the choke as close to the controller as possible.

UMV 2301 AS	Self-MC choke
8T to 11T	11T
16T to 27T	27T
33T to 50T	50T
60T to 75T	75T
100T to 120T	120T

3.5.6.2 - RFI filters

The use of an RFI filter reduces the emission level of radio frequency signals, but its influence on interference phenomena is rather limited.

Depending on the type of controller, install the recommended RFI filter as described in the table below, between the mains and the controller input.

UMV 2301 AS	Length of motor cable (m)	Reference of filter
8T and 16T	1 to 75	FLT - 3027
22T to 33T	1 to 75	FLT - 1051
40T	1 to 75	FLT - 1071
50T and 60T	1 to 75	FLT - 1111
75T to 120T	1 to 75	FLT - 1171

• Precautions when installing filters

- Place the filter as close to the controller as possible.
- Fasten the filter directly on the same grille or base plate as the controller.

• Precautions for filter wiring

- Maximum length of cable towards the controller will be 0,3 m.
- Separate motor cables from mains cables.
- Earth wiring : input at general earth of cubicle, output at controller earth.

3.5.6.3 - Controller - motor wiring

Use a shielded cable between controller and motor.

• Cable specifications

Use a shielded or armed cable with 3 phases + earth, with a low leakage capacity between the shielding or the armature.

• Connection of shieldings

- Connect the shielding at both ends : to the motor earth terminal and the controller earth terminal (or to earth bus at filter output).

- Strip the cable envelope and fasten the shielding to the the base grille or the base plate of the cubicle with a metallic clamp.

- If possible, connect the shielding to the earth of the cubicle at the cable outlet by using for instance brass packing boxes and stripping the cable envelope.

• Advice for the continuity of shieldings

- When the motor is connected with the intermediary terminal block in the cubicle, connect the shielding to a terminal not insulated from the base grille or base plate. If the terminal is located further than 300 mm from the edge of the grille, fasten the shielding with a metallic clamp.

- When a circuit-breaking device is used near the motor, use a bonding jumper not exceeding 100mm to ensure continuity.

Speed controllers for asynchronous motors UMV 2301 AS

3.5.7 - Conformity to standards

Tests carried out according to conditions specified in the standards show that the UMV 2301 AS controllers conform to EMC directive 89/336/CEE modified by 92/31/CEE, provided they are installed and connected according to instructions given in paragraphs 3.5.5 and 3.5.6.

3.5.7.1 - Immunity

The UMV 2301 AS controllers conform to international immunity standards.

Standard	Type of immunity	Application	Level
EN 61000-4-2*	Electrostatic discharge	Housing of equipment	Level 3 (industrial)
EN 61000-4-3	Radiated radio frequency	Housing of equipment	Level 3 (industrial)
ENV 50140*	Radiated radio frequency	Housing of equipment	Level 3 (industrial)
ENV 50141*	Emitted radio frequency	Control and power cables	Level 3 (industrial)
EN 61000-4-4*	Successive rapid transients	Control cables	Level 4 (industrial, reinf)
		Power cables	Level 3 (industrial)
CEI 1000-4-5	Shock waves	Supply cables between phase and earth	Level 4
		Supply cables between phases	Level 4
CEI 1000-4-11	Voltage drops, momentary cuts and voltage variations	Supply cables	Level 4
EN 50082-1	Generic immunity standards, Part 1 : residential, commercial and light industry	-	Conforming
EN 50082-2	Generic immunity standards, Part 2 : industrial environment. Concern basic standards marked with*	-	Conforming

3.5.7.2 - Conducted emissions

UMV 2301AS controllers used in conjunction with associated filters are conforming to standards relating to conducted emissions according to conditions given hereunder.

UMV 2301 AS 8T to 16T Motor cable length (m)	Switching frequency (kHz)				
	3	4,5	6	9	12
1	R	R	R	R	R
5	R	R	R	R	R
10	R	R	R	R	I
20	R	R	R	I	I
50	I	I	I	I	# I
75	I	I	I	#	#

Symbols	Standards	Description	Application
R	EN50081-1	Generic emission standard for residential, commercial and light industrial environment	AC mains supply
I	EN50081-2	Generic emission standard for industrial environment	AC mains supply
#	Requires a special technique. Ex. : input filters, output filters. Ask LEROY-SOMER.		

Conducted emission levels specified in standards EN 50081-1 and 50081-2 are equivalent with the levels required in following specific standards :

Conducted emissions from 150 kHz to 30 MHz		
Generic standard	Specific standard	
EN 50081-1	EN 55011 Class B CISPR 11 Class B	Industrial, scientific and medical equipments
	EN 55014 CISPR 14	Electro-domestic equipments
	EN 55022 Class B CISPR 22 Class B	Data processing equipments
EN 50081-2	EN 55011 Class A Group 1 CISPR 11 Class A Group 1	Industrial, scientific and medical equipments
	EN 55022 Class A CISPR 22 Class A	Data processing equipments

Speed controllers for asynchronous motors UMV 2301 AS

3.5.7.3 - Radiated emissions

When the controller is installed in a steel cubicle and when wiring precautions have been followed, it conforms to the radiated emission limits specified in generic emission standard EN 50081-2, industrial environment part.

Tests have been carried out with a cubicle representative of the commonest installations. It could happen, for an equipment with different specifications, that the radiated emission levels may not be the same as those measured during tests.

The table hereunder summarizes the results for radiated emissions and give the six most unfavourable measurements between 30 and 1000 MHz.

UMV 2301 AS 8T to 16T		Maximum level permitted by industrial standard EN 50081-2 at 10m
Frequency (MHz)	Emissions (dB μ V/m)	
31	30	40
32	33	40
33	32	40
34	32	40
35	31	40
40	33	40

Radiated emission levels specified in standards EN 50081-1 and 50081-2 are equivalent with the levels required in following specific standards :

Radiated emissions from 30 to 1000 MHz		
Generic standard	Specific standard	
EN 50081-1	EN 55011 Class B Group 1 CISPR 11 Class B Group 1	Industrial, scientific and medical equipments
	EN 55022 Class B CISPR 22 Class B	Data processing equipments
EN 50081-2	EN 55011 Class A Group 1 CISPR 11 Class A Group 1	Industrial, scientific and medical equipments
	EN 55022 Class A CISPR 22 Class A	Data processing equipments

3.5.8 - Recommendations in case of interference phenomena

In spite of the strict respect of the elementary precautions described in paragraph 3.5.5, it may happen in a few cases that some components of the installation are disturbed. This more generally concerns the sensitive measurement probes.

Experience shows that the most costly solutions are not necessarily the most efficient and in most cases very simple arrangements give the best results.

All the following actions should not be systematically carried out, it is enough to stop just after the phenomenon has disappeared.

- Check that the elementary precautions described in paragraph 3.5.5 have been respected.
- Mounting of probes : insulation from the metallic structure common to the motor.
- Shielding of probes.

Measurement probes are sensitive components that may be disturbed.

Most of the problems can be solved with small decoupling capacitors (0,1 to 0,5 μ F) on the probe feedback signals. This solution is only possible with DC voltage signals (12, 24 or 48V) or with 50 Hz AC voltage up to 220V.

- Protection of sensitive components.

If the controller power is much higher than the power of sensitive components connected on the same network, it will be more economical to install an RFI filter on the supply of the low power components than to install an RFI filter on the controller input. The installation precautions are the same : filter placed close to the component, short earth connection, separation of the filter input and output cables.

- Auxiliary cables for shielding of control electronics.
In the event of these connections passing through highly disturbed areas, it might be advisable to double their shielding with an auxiliary cable connected at both ends. Circulation currents are thus concentrated in this cable and not in the shielding of the low level connections.

- Self-MC choke

Install and connect a Self-MC choke between the controller and the motor as described in § 3.5.6.1.

- RFI filter

Install and connect an RFI filter (mains) between the controller and the motor as described in § 3.5.6.2.

- Shielded motor cable

Between the motor and the controller, use a shielded cable according to the recommendations in § 3.5.6.3.

3.5.9 - Additional information

LEROY-SOMER is at the service of the manufacturer, the installer or the user to provide any additional infor-

mation which would not appear in this documentation, as well as for any technical assistance for solving a specific problem.

Speed controller for asynchronous motors UMV 2301 AS

3.6.5 - Control from terminal block Speed reference via analogue input or Faster / Slower command

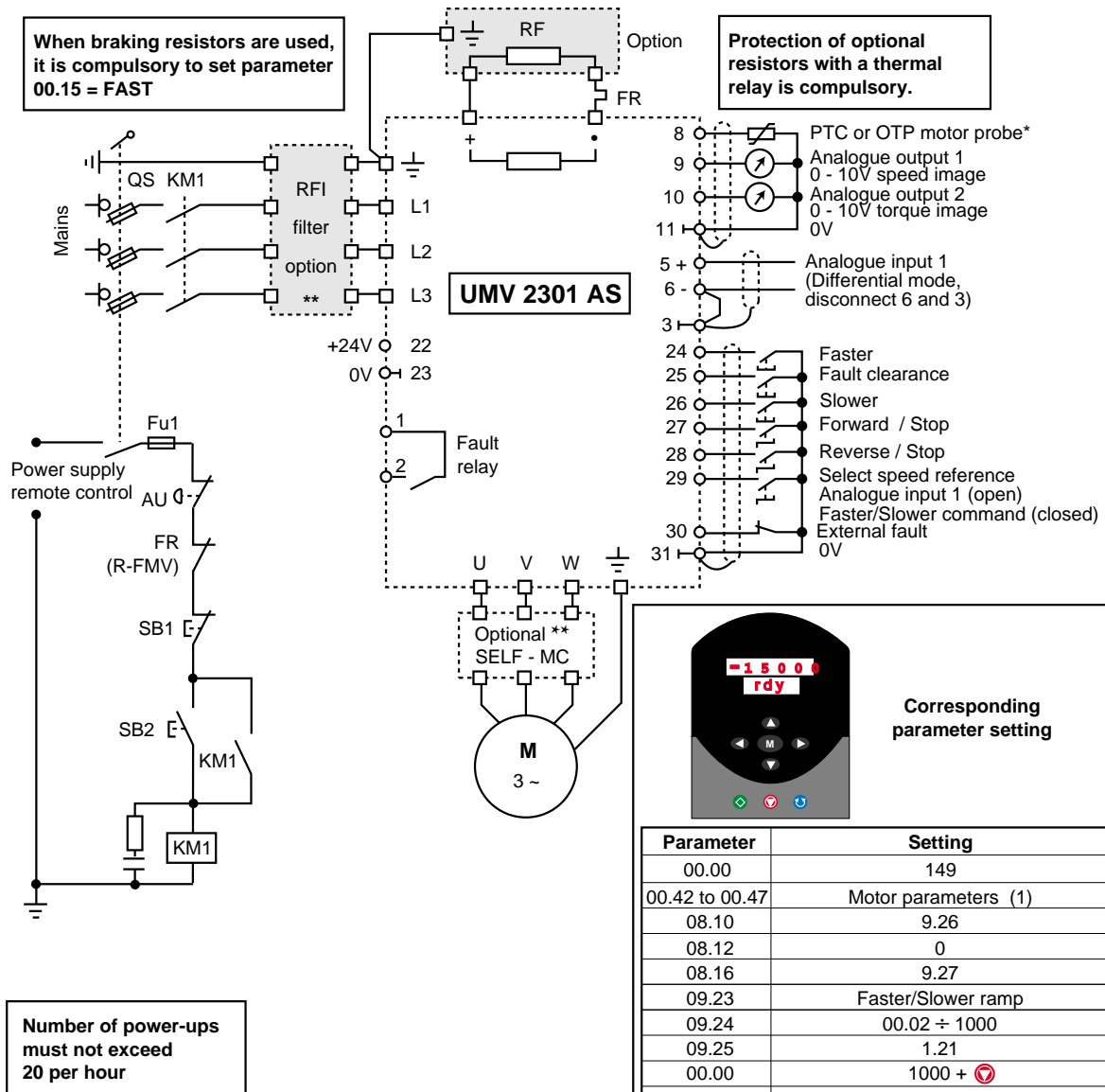

- QS : Fuse cut-out.
- AU : Emergency stop button.
- SB1 : Power-down button.
- SB2 : Power-up button.
- KM1 : Line switch.
- FR : Optional resistors thermal relay.
- RP : 10kΩ potentiometer
- * PTC or OTP probe : connect terminals 8 and 11 if not fitted.
- ** See § 7.

Note : Switch and relay coils should be fitted with an RC.

(1) CAUTION :
Before giving any run command, the parameter setting corresponding to the diagram above must absolutely be completed with the commissioning procedure described in § 4.2.

Speed controller for asynchronous motors UMV 2301 AS

3.6.6 - Control from terminal block PID loop with analogue reference

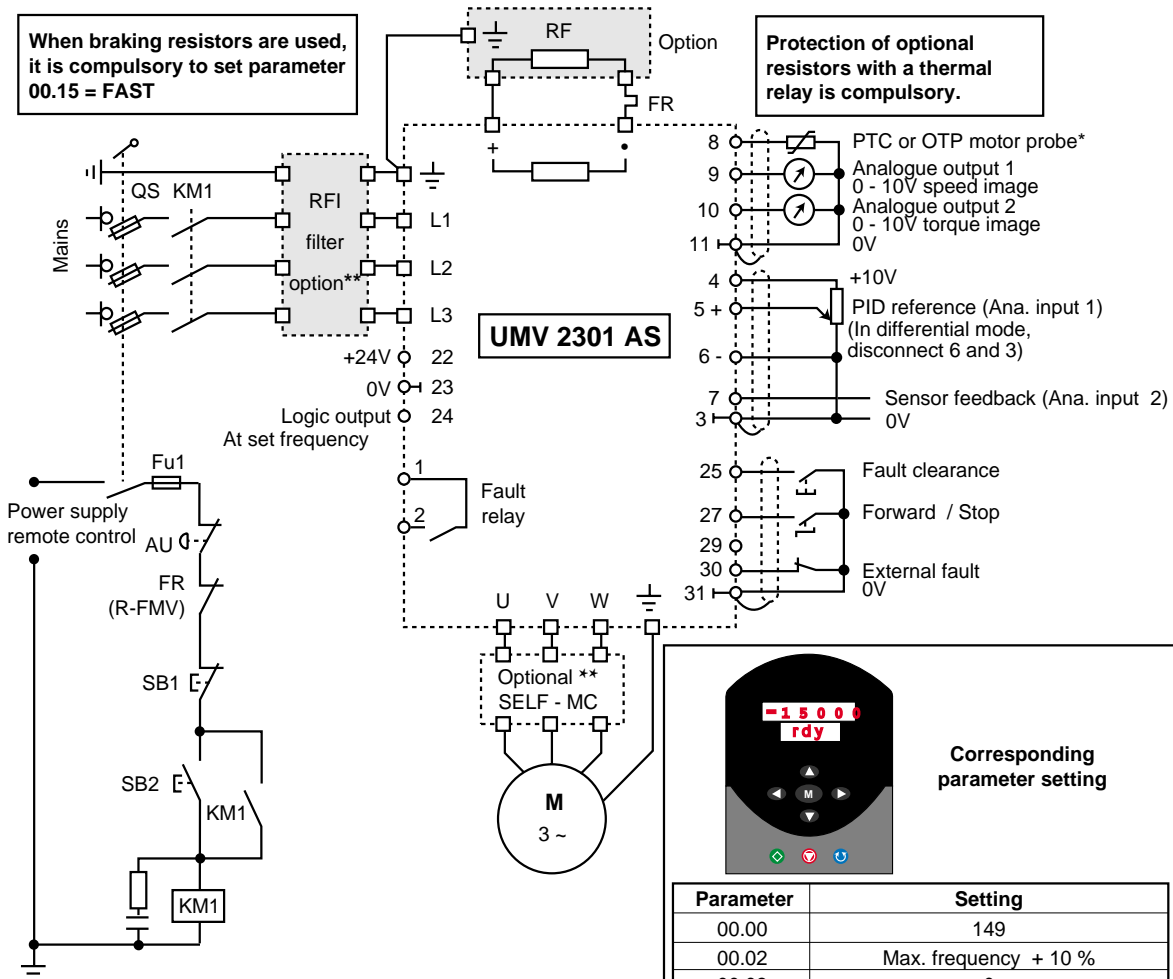

Number of power-ups must not exceed 20 per hour

- QS : Fuse cut-out.
- AU : Emergency stop button.
- SB1 : Power-down button.
- SB2 : Power-up button.
- KM1 : Line switch.
- FR : Optional resistors thermal relay.
- RP : 10kΩ potentiometer
- * PTC or OTP probe : connect terminals 8 and 11 if not fitted.
- ** See § 7.

Note : Switch and relay coils should be fitted with an RC.

(1) CAUTION :
Before giving any run command, the parameter setting corresponding to the diagram above must absolutely be completed with the commissioning procedure described in § 4.2.

Corresponding parameter setting

Parameter	Setting
00.00	149
00.02	Max. frequency + 10 %
00.03	0
00.04	Min deceleration ramp
00.42 to 00.47	Motor parameters (1)
07.08	0.9
07.10	1.27
07.14	1.28
14.03	1.27
14.04	1.28
14.07	PID slew rate
14.08	1
14.09	8.04
14.10	Proportional gain (P)
14.11	Integral gain (I)
14.12	Derivative gain (D)
14.13	High limit
14.14	0
14.16	1.36
00.00	1000 +

Speed controller for asynchronous motors UMV 2301 AS

3.6.7 - Control from terminal block PID loop with 4 preset frequencies

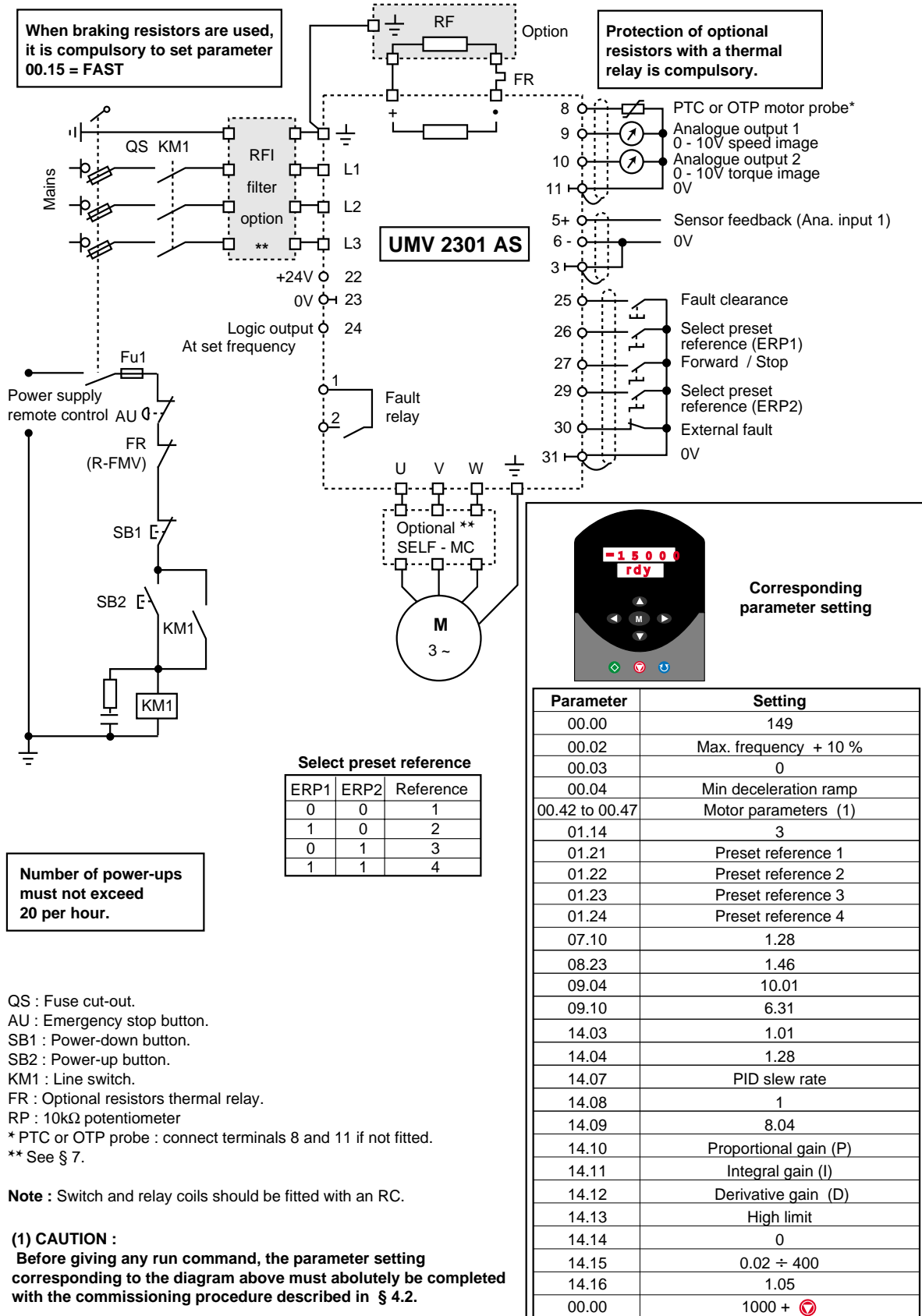

QS : Fuse cut-out.
 AU : Emergency stop button.
 SB1 : Power-down button.
 SB2 : Power-up button.
 KM1 : Line switch.
 FR : Optional resistors thermal relay.
 RP : 10kΩ potentiometer
 * PTC or OTP probe : connect terminals 8 and 11 if not fitted.
 ** See § 7.

Note : Switch and relay coils should be fitted with an RC.

Speed controller for asynchronous motors UMV 2301 AS

4 - COMMISSIONING



- The controllers use a software, which is adjusted with parameters.
- The performance level depends on the parameter setting.
- Incorrect settings may have severe consequences for personnel and machinery.
- The parameter setting of the controllers should only be carried out by experienced and qualified personnel.

4.1 - Procedure for using the keypad

4.1.1 - Presentation

All keypads are identical and provide access to adjustment parameters and control of the drive.

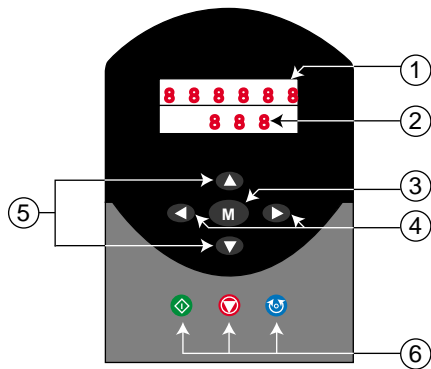

- ① Upper display consisting of six 7-segment display lines showing :
 - operating mode,
 - parameter content,
 - trip code.
- ② Lower display consisting of four 7-segment display lines showing :
 - controller operation status,
 - adjustment parameters, consisting of the menu and the parameter.
- ③ 1 mode **M** key used for switching from normal to parameter mode (in parameter mode, the upper display is flashing).
- ④ 2 keys **◀ ▶** used for moving under the 7-segment display lines of the upper display, to modify the values or switch to another menu.
- ⑤ 2 keys **▲ ▼** used for scrolling parameters and to modify their value.
- ⑥ 3 keys **◇ ○ ↻** for implementing the following commands from the keypad :
 - ◇** (green key) : Run,
 - (red key) : Stop, Reset,
 - ↻** (blue key) : Reverse rotation.

4.1.2 - Adjustment parameters

The drive is configured for a given application using the setting of parameters which are organized into menus.

Each menu corresponds to a group of parameters organized in specific functional groups.

This manual describes the parameters in menu 0, which includes the essential parameters of the different menus being useful for a quick and simple starting-up in the different standard operating modes.

The other menus and parameters are protected by an access code.

Access to the digital or bit (value 0 or 1) parameters is possible :

- either in « read only » mode (LS), for instance : speed image or motor current image,
- or in « read write » mode (LE), for instance : acceleration ramp.



















Speed controller for asynchronous motors UMV 2301 AS

4.1.3 - Modification of parameters



Action		Display	Comments												
Power-up of controller		<table border="1"> <tr><td>H</td><td>V</td><td>A</td><td>C</td></tr> <tr><td>r</td><td>d</td><td>Y</td><td></td></tr> </table>	H	V	A	C	r	d	Y		During 1 second after power-up, the upper display shows the control mode which has been selected.				
H	V	A	C												
r	d	Y													
1 second after power-up		<table border="1"> <tr><td></td><td></td><td></td><td></td><td>0</td></tr> <tr><td></td><td>r</td><td>d</td><td>Y</td><td></td></tr> </table>					0		r	d	Y		Upper display shows motor speed		
				0											
	r	d	Y												
Switch to parameter mode		<table border="1"> <tr><td></td><td></td><td></td><td></td><td>0</td></tr> <tr><td>0.</td><td>1</td><td>0</td><td></td><td></td></tr> </table>					0	0.	1	0			Parameter 0.10 corresponds to motor speed		
				0											
0.	1	0													
Access to the different parameters		<table border="1"> <tr><td></td><td></td><td></td><td></td><td>0</td></tr> <tr><td>0.</td><td>1</td><td>1</td><td></td><td></td></tr> </table>					0	0.	1	1			The key switches from a parameter to the next one. Content of parameters is shown on upper display.		
					0										
	0.	1	1												
	<table border="1"> <tr><td></td><td></td><td></td><td></td><td>0</td></tr> <tr><td>0.</td><td>1</td><td>0</td><td></td><td></td></tr> </table>					0	0.	1	0			The key switches from a parameter to the previous one			
				0											
0.	1	0													
+ simultaneously		<table border="1"> <tr><td></td><td></td><td></td><td></td><td>0</td></tr> <tr><td>0.</td><td>0</td><td>0</td><td></td><td></td></tr> </table>					0	0.	0	0			Simultaneous action on the keys & provides immediate access to parameter 0 of the currently selected menu		
				0											
0.	0	0													
Modification of a digital parameter example : setting parameter 0.01 (minimum speed) at 5Hz		<table border="1"> <tr><td></td><td></td><td></td><td></td><td>0.</td><td>0</td></tr> <tr><td>0.</td><td>0</td><td>1</td><td></td><td></td><td></td></tr> </table>					0.	0	0.	0	1				Access to parameter 0.01
					0.	0									
	0.	0	1												
		<table border="1"> <tr><td></td><td></td><td></td><td></td><td>0.</td><td>0</td></tr> <tr><td></td><td>0.</td><td>0</td><td>1</td><td></td><td></td></tr> </table>					0.	0		0.	0	1			Action on provides access to parameter 0.01
					0.	0									
	0.	0	1												
	<table border="1"> <tr><td></td><td></td><td></td><td></td><td>0.</td><td>0</td></tr> <tr><td></td><td>0.</td><td>0</td><td>1</td><td></td><td></td></tr> </table>					0.	0		0.	0	1			Move the cursor to the digit to be modified	
				0.	0										
	0.	0	1												
5 x	<table border="1"> <tr><td></td><td></td><td></td><td></td><td>5.</td><td>0</td></tr> <tr><td></td><td>0.</td><td>0</td><td>1</td><td></td><td></td></tr> </table>					5.	0		0.	0	1			Set to required value	
				5.	0										
	0.	0	1												
	<table border="1"> <tr><td></td><td></td><td></td><td></td><td>5.</td><td>0</td></tr> <tr><td></td><td>0.</td><td>0</td><td>1</td><td></td><td></td></tr> </table>					5.	0		0.	0	1			Enter setting and leave content of parameter 0.01	
				5.	0										
	0.	0	1												
Modification of bit parameter Example : selection of dynamic V to F mode	8 x	<table border="1"> <tr><td></td><td></td><td>b</td><td>i</td><td>t</td><td>1</td></tr> <tr><td></td><td>0.</td><td>0</td><td>9</td><td></td><td></td></tr> </table>			b	i	t	1		0.	0	9			Selection of dynamic V to F mode corresponds to parameter 0.09
			b	i	t	1									
		0.	0	9											
		<table border="1"> <tr><td></td><td></td><td>b</td><td>i</td><td>t</td><td>1</td></tr> <tr><td></td><td>0.</td><td>0</td><td>9</td><td></td><td></td></tr> </table>			b	i	t	1		0.	0	9			Access to content of parameter 0.09
		b	i	t	1										
	0.	0	9												
	<table border="1"> <tr><td></td><td></td><td>b</td><td>i</td><td>t</td><td>0</td></tr> <tr><td></td><td>0.</td><td>0</td><td>9</td><td></td><td></td></tr> </table>			b	i	t	0		0.	0	9			Enable dynamic V to F mode by setting bit to 1	
		b	i	t	0										
	0.	0	9												
	<table border="1"> <tr><td></td><td></td><td>b</td><td>i</td><td>t</td><td>0</td></tr> <tr><td></td><td>0.</td><td>0</td><td>9</td><td></td><td></td></tr> </table>			b	i	t	0		0.	0	9			Enable selection and leave content	
		b	i	t	0										
	0.	0	9												

Speed controller for asynchronous motors UMV 2301 AS

4.1.3 - Modification of parameters (end)

Action	Display	Comments												
Parameter memorization when adjustments have been completed	 +  simultaneously	<table border="1"><tr><td></td><td></td><td></td><td></td><td>0</td></tr><tr><td>0.</td><td>0</td><td>0</td><td>0</td><td></td></tr></table>					0	0.	0	0	0		Go to parameter 0.00	
					0									
	0.	0	0	0										
		<table border="1"><tr><td></td><td></td><td></td><td></td><td>0</td></tr><tr><td>0.</td><td>0</td><td>0</td><td>0</td><td></td></tr></table>					0	0.	0	0	0		Enter content of parameter 0.00	
					0									
0.	0	0	0											
3 x 	<table border="1"><tr><td></td><td></td><td>-</td><td></td><td>0</td></tr><tr><td></td><td></td><td></td><td></td><td></td></tr></table>			-		0						Move the cursor to the 4th digit from the right		
		-		0										
	<table border="1"><tr><td></td><td></td><td>1</td><td>0</td><td>0</td><td>0</td></tr><tr><td>0.</td><td>0</td><td>0</td><td>0</td><td></td><td></td></tr></table>			1	0	0	0	0.	0	0	0			Press key  in order to show 1000 on upper display
		1	0	0	0									
0.	0	0	0											
	<table border="1"><tr><td></td><td></td><td>1</td><td>0</td><td>0</td><td>0</td></tr><tr><td>0.</td><td>0</td><td>0</td><td>0</td><td></td><td></td></tr></table>			1	0	0	0	0.	0	0	0			Press red key  to memorize all parameters
		1	0	0	0									
0.	0	0	0											
Switching to another menu		<table border="1"><tr><td></td><td></td><td></td><td></td><td>0</td></tr><tr><td>0.</td><td>0</td><td>0</td><td>0</td><td></td></tr></table>					0	0.	0	0	0			
					0									
	0.	0	0	0										
		<table border="1"><tr><td></td><td></td><td></td><td></td><td>0</td></tr><tr><td>0.</td><td>0</td><td>0</td><td>0</td><td></td></tr></table>					0	0.	0	0	0		Enter into content of parameter 0.00	
					0									
	0.	0	0	0										
	9 x 	<table border="1"><tr><td></td><td></td><td></td><td></td><td>9</td></tr><tr><td></td><td></td><td></td><td></td><td></td></tr></table>					9						Display 9	
					9									
		<table border="1"><tr><td></td><td></td><td></td><td>-</td><td>9</td></tr><tr><td></td><td></td><td></td><td></td><td></td></tr></table>				-	9						Move the cursor to the digit located left of 9	
			-	9										
4 x 	<table border="1"><tr><td></td><td></td><td></td><td>4</td><td>9</td></tr><tr><td></td><td></td><td></td><td></td><td></td></tr></table>				4	9						Display 49		
			4	9										
	<table border="1"><tr><td></td><td></td><td></td><td>-</td><td>4</td><td>9</td></tr><tr><td></td><td></td><td></td><td></td><td></td><td></td></tr></table>				-	4	9							Move the cursor to the digit located left of 4
			-	4	9									
	<table border="1"><tr><td></td><td></td><td></td><td>1</td><td>4</td><td>9</td></tr><tr><td></td><td></td><td></td><td></td><td></td><td></td></tr></table>				1	4	9							Display 149
			1	4	9									
	<table border="1"><tr><td></td><td></td><td></td><td>1</td><td>4</td><td>9</td></tr><tr><td>0.</td><td>0</td><td>0</td><td>0</td><td></td><td></td></tr></table>				1	4	9	0.	0	0	0			Enable selection
			1	4	9									
0.	0	0	0											
	<table border="1"><tr><td></td><td></td><td></td><td></td><td></td><td>0</td></tr><tr><td>1.</td><td>0</td><td>0</td><td>0</td><td></td><td></td></tr></table>						0	1.	0	0	0			The key  switches to the next menu
					0									
1.	0	0	0											
	<table border="1"><tr><td></td><td></td><td></td><td></td><td></td><td>0</td></tr><tr><td>0.</td><td>0</td><td>0</td><td>0</td><td></td><td></td></tr></table>						0	0.	0	0	0			The key  switches to the previous menu
					0									
0.	0	0	0											

Additional information

- Without any operation on the console during 8s, the display returns to parameter 00.10 (motor speed).
- A continuous action on keys  and  provides quick scrolling.

Speed controller for asynchronous motors UMV 2301 AS

4.2 - Starting-up the controller

- ⚠** • Before the controller is powered up, make sure that all power connections are correct, that motor connection is correct and that moving or rotating parts are mechanically protected.
- The users must be especially careful to avoid accidental starts of the controller.

4.2.1 - Reset function



Notice :

Reset of the controller must be performed in the following situations :

- reset after controller trip,
- after modification of operating mode,
- when new values have been entered for certain parameters marked with  .

Enabling and memorization of new values can be performed whilst the controller is running.

- Procedure :

- with the terminal block : close trip reset contact (terminal 25),
- from keypad : press key  when the controller is stopped ,
- keep pressing run key  and press reset key  whilst the controller is running.

4.2.2 - Using parameter 00.00

- ⚠** Before going back to factory settings , make sure that the safety of the system will not be affected.

Set the following values for parameter 00.00 in order to get the functions listed hereunder :

Setting of 00.00	Function	Action
149	Access to other menus	Press on reset 
1000	Memorization of new values	
1244	Return to US factory settings	
1255	Return to European factory settings	
2000	Locked access to other menus	

4.2.3 - Selection of run command

- From the keypad (see wiring diagram in § 3.6.1) : run, stop and speed control commands with the keys.
- With the terminal block (see wiring diagram in § 3.6.2) : run, stop and speed control command with the terminal block (connector).

Parameter	Setting/Display	Description
00.05	0	Selection of analogue reference 1 or 2 with terminal 29
	1	Analogue speed reference 1
	2	Analogue speed reference 2
	3	Preset frequencies
	4	Command from the keypad
00.00	1000	Reset memorization 

4.2.4 - Programming motor parameters

- ⚠** • The values of the motor parameters affect motor protection and safety of system.
- Set values of the parameters must be read on the nameplate of the motor.
 - Motor parameters must be adjusted with a minimum accuracy of 10% of rated values in order to achieve good performance.

Parameter	Description	Factory setting	Adjustmen range	Unit
00.42	Nr of poles	4	2 to 24	Poles
00.43	Power factor (cos φ)	0.85	0 to 1.0	-
00.44	Rated motor voltage	400 (460)	0 to 480	V
00.45	Rated motor speed	0	0 to 6000	min ⁻¹
00.46	Rated motor current	I _{max} controll.	0 to I _{max} controller	A
00.47	Rated motor frequency	50 (60)	0 to 1000	Hz
00.00	Memorization	0	1000 + reset 	-

- * Before programming a high speed, make sure that the motor and machinery can withstand it.
() USA settings.

Speed controller for asynchronous motors UMV 2301 AS

4.2.5 - Self-calibration of controller to motor

- **During self-calibration phase, the controller powers the motor, thus causing it to rotate.**
- **Make sure this operation does not affect safety.**

During self-calibration, the specifications of the motor are measured and the controller adapts automatically.

- Make sure that the motor is disconnected from its load.
- Power up the controller.
- Connect lock input (terminal 30) to terminal 0V (terminal 31).
- Set value of parameter 00.40 to 1. The self-calibration sequence begins.

The motor accelerates up to half speed. The controller measures the magnetizing current, then decelerates and stops the motor. The value of the power factor is measured and automatically entered in parameter 00.43. Parameter 00.40 returns to 0.

4.2.6 - Control from the terminal block

- Refer to diagram § 3.6.2.
- Make at least the following connections :

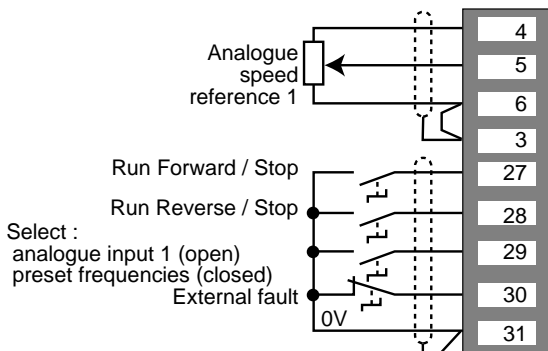

- Set potentiometer at minimum level.
- Leave terminal 29 open for the selection of analogue reference 1.
- Power up the controller, the lower display shows " rdy ".
- Display parameter 00.10 to read speed measurement.
- Close the lock (terminal 30).
- Give a run or reverse command (terminal 27 or 28).
- Give a speed reference with the potentiometer. The upper display shows speed in min^{-1} .
- Disable run command (by opening terminal 27 or 28), the motor decelerates and stops. The display shows « rdy ».

4.2.7 - Control from the keypad

- Refer to diagram § 3.6.1.
- Make at least the following connections

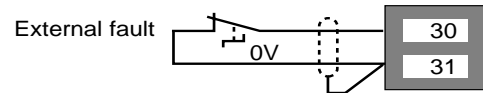

- Do not connect terminal 29 to 0V.
- Close the lock (terminal 30) to 0V (terminal 31).
- Power up the controller, the lower display shows " rdy ".
- Set parameter 00.05 to 4 (selection of speed reference from keypad).
- Display parameter 00.10 to read speed measurement.
- Press key to start.
- Wait until lower display shows « Run ».
- Press key to increase speed.
- Press key to reduce speed.
- Press key to reverse rotation.
- Press key to stop the motor, the display shows « rdy ».

Notice : to set the other parameters, refer to the open or closed loop block diagrams on next pages, with the description of the parameters.

Speed controller for asynchronous motors UMV 2301 AS

4.3 - Menu 0

4.3.1 - Menu 0 block diagram

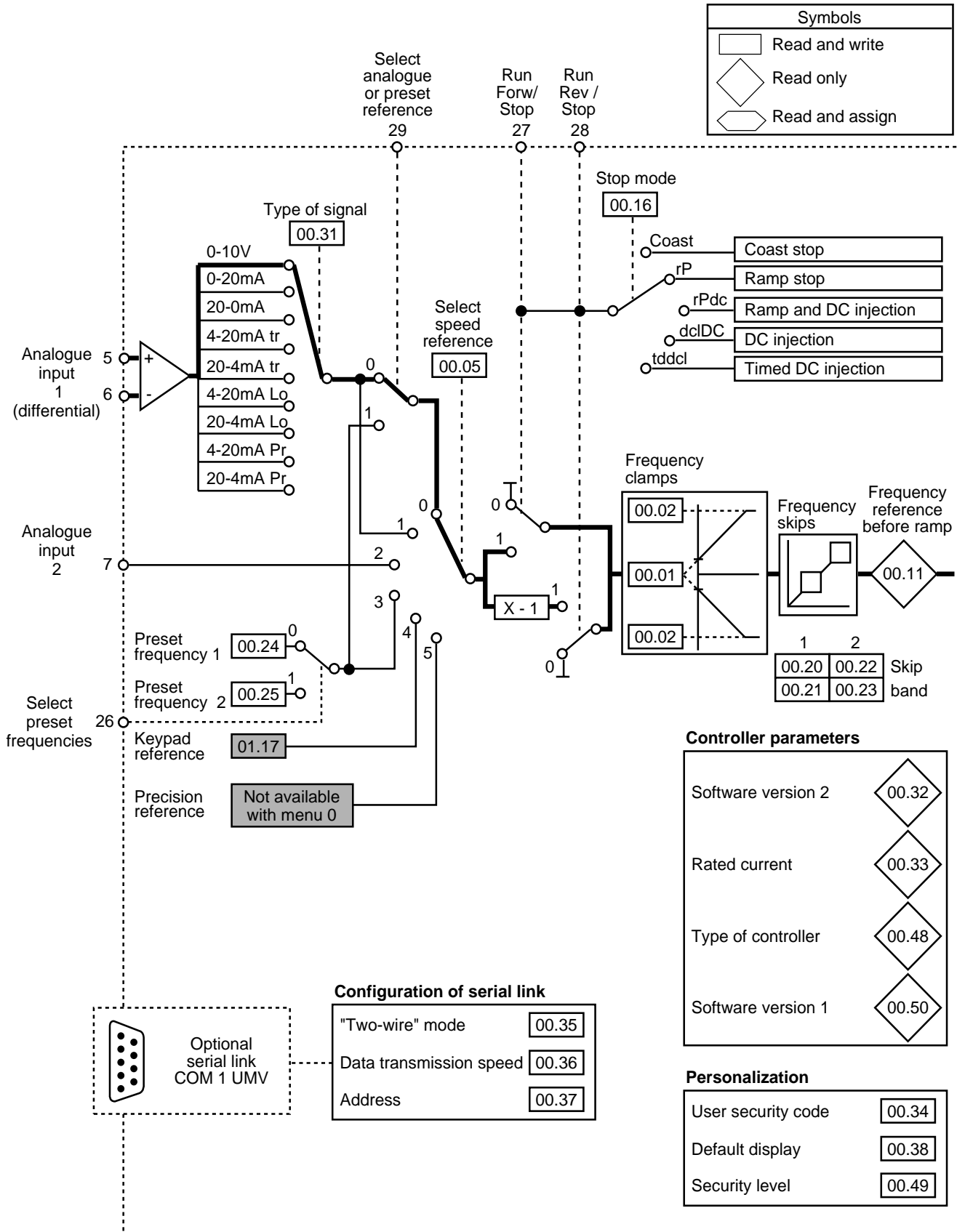

Speed controller for asynchronous motors UMV 2301 AS

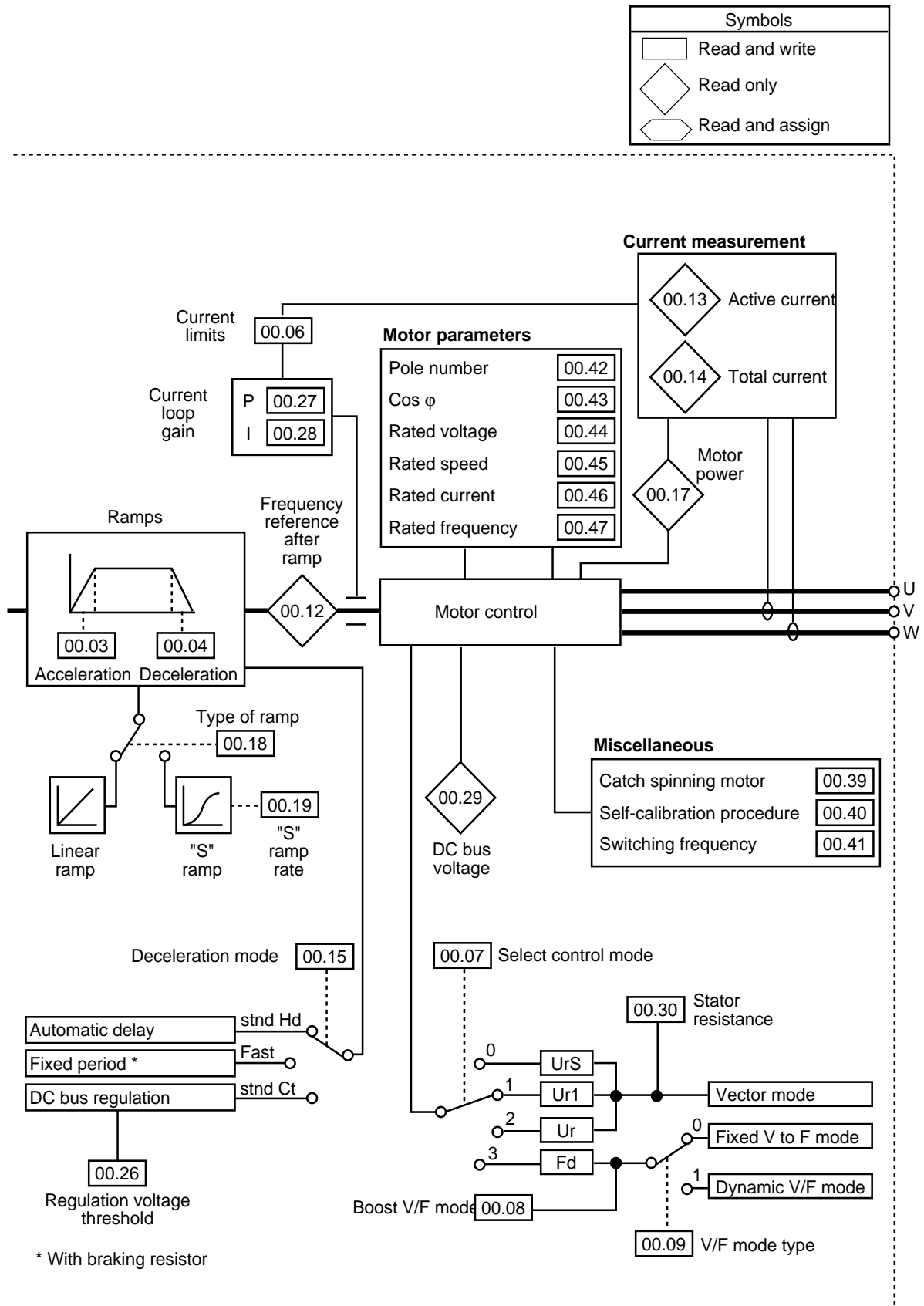

Speed controller for asynchronous motors UMV 2301 AS

4.3.2 - List over parameters in menu 0

Parameter	Description	Type	Adjustment range	Factory setting
00.00	Memorization Factory Settings Access code to other menus	R - W	0 to 2000 1000 : memorization 1244 : US factory settings 1255 : Euro factory settings 149 : Access code to other menus 2000 : Locked access to other menus	0
00.01	Minimum frequency clamp	R - W	0 to 1000.0 Hz	0.0 Hz
00.02	Maximum frequency clamp	R - W	0 to 1000.0 Hz	50.0 Hz
00.03	Acceleration ramp	R - W	0 to 3200.0s/100Hz	60.0s/100Hz
00.04	Deceleration ramp	R - W	0 to 3200.0 s/100 Hz	60.0s/100Hz
00.05	Select speed references	R - W	0 to 5	0
00.06	Current limits	R - W	0 to 150%	120 %
00.07	Select control mode	R - W	Urs, Ur1, Ur, Fd	Ur1
00.08	Starting torque (Boost)	R - W	0 to 25 %	3.0 %
00.09	Select dynamic V to F mode	R - W	0 - 1	1
00.10	Calculated motor speed	RO	0 to $\pm 60000 \text{ min}^{-1}$	-
00.11	Pre-ramp speed reference	RO	0 to $\pm 1000.0 \text{ Hz}$	-
00.12	Post-ramp speed reference	RO	0 to $\pm 1000.0 \text{ Hz}$	-
00.13	Measurement of motor active current	RO	0 to $\pm I \text{ max (A)}$	-
00.14	Total motor active current	R - W	0 to 400.0 Hz	-
00.15	Select deceleration mode	R - W	Std.Ct, Std.Hd, FAST	Std.Ct
00.16	Select stop mode	R - W	Coast, rp, rp.dc1, dc1, tdc1	rp
00.17	Motor power	R - W	$(\pm I \text{ max} \times 0.44 \times \sqrt{3})/1000$	-
00.18	Select linear ramp / S ramp	R - W	0 - 1	0
00.19	S ramp rate	R - W	0 to 3000.0 s ² /100 Hz	450.0 s ²
00.20	Frequency skip 1	R - W	0 to 1000.0 Hz	0.0
00.21	Frequency skip band 1	R - W	0 to 5,0 Hz	0,5 Hz
00.22	Frequency skip 2	R - W	0 to 1000.0 Hz	0.0
00.23	Frequency skip band 2	R - W	0 to 5,0 Hz	0.5 Hz
00.24	Preset frequency 1	R - W	0 to $\pm 1000.0 \text{ Hz}$	0.0 Hz
00.25	Preset frequency 2	R - W	0 to $\pm 1000.0 \text{ Hz}$	0.0 Hz
00.26	DC bus regulation voltage threshold	R - W	0 to 800V	700 V
00.27	Current loop proportional gain	R - W	0 to 4000	20
00.28	Current loop integral gain	R - W	0 to 4000	40
00.29	DC bus voltage	RO	0 to 830V	-
00.30	Stator resistance	R - W	0 à 32.000 Ω	0.000 Ω
00.31	Type of signal, analogue input 1	R - W	Volt, 0.20, 20.0, 4.20tr, 20.4tr, 4.20 lo, 20.4lo, 4.20Pr, 20.4Pr	Volt
00.32	Software version 2	RO	1 to 99	-
00.33	Controller rated current	RO	12.0 to 180.0A	-

Speed controller for asynchronous motors UMV 2301 AS

4.3.2 - List over parameters of menu 0

Parameter	Description	Type	Adjustment range	Factory setting
00.34	User security code	R - W	0 to 255	149
00.35	Serial link : 2-wire mode	R - W	0 or 1	0
00.36	Serial link transmission rate	R - W	4800, 9600, 19200, Bauds	4800 Bauds
00.37	Serial link controller address	R - W	0 to 9,9	1,1
00.38	Parameter displayed on power-up	R - W	0 to 0.50	0.10
00.39	Catch spinning motor	R - W	0 - 1	0
00.40	Self-calibration	R - W	0 - 1	0
00.41	Switching frequency *	R - W	3 - 4,5 - 6 - 9 - 12 kHz	3 kHz
00.42	Motor pole number	R - W	2 to 24 poles	4 poles
00.43	Power factor (cos φ)	R - W	0 to 1.000	0,850
00.44	Motor rated voltage	R - W	0 to 480 V	400 V
00.45	Motor rated speed	R - W	0 to 6000.0 min ⁻¹	0
00.46	Motor rated current	R - W	0 to IN. VAR.	IN. VARIATEUR
00.47	Motor rated frequency	R - W	0 to 1000.0 Hz	50.0 Hz
00.48	Controller operating mode	RO	-	HVAC
00.49	Security status	RO	0 - 1 / 0 - 1 / 0 - 1	0 / 0 / 1
00.50	Software version 1	RO	1.00 to 99.99	Depending on software version of product

* See necessary derating § 1.3.2 depending on set frequency.

Speed controller for asynchronous motors UMV 2301 AS

4.3.5 - Description of parameters in menu 0

Symbols :

00.00 : Parameter for memorization, return to European and US factory settings

149 : access to other menus,
1000 : memorization,
1244 : return to US factory settings,
1253 : selection of operating mode,
1255 : return to European factory settings,
2000 : locked access to other menus.

00.01 : Minimum frequency clamp

Range : 0 to 1000.0 Hz

Factory setting : 0.0 Hz

Increments of 0,1 Hz.

It is the lowest operating frequency. With this parameter set to minimum value, it corresponds to output frequency.

00.02 : Maximum frequency clamp

Range : 0 to 1000.0 Hz

Factory setting : 50.0 Hz

Increments of 0,1 Hz.

It is the highest operating frequency. With this parameter set to maximum value, it corresponds to output frequency.

00.03 : Acceleration ramp

Range : 0 to 3200.0s/100Hz

Factory setting : 60.0s/100Hz

Increments of 0,1s.

Sets acceleration time from 0 to 100 Hz.

$$\text{Value of 00.03 (s)} = \frac{t(\text{s}) \times 100\text{Hz}}{(F2-F1) \text{ Hz}}$$

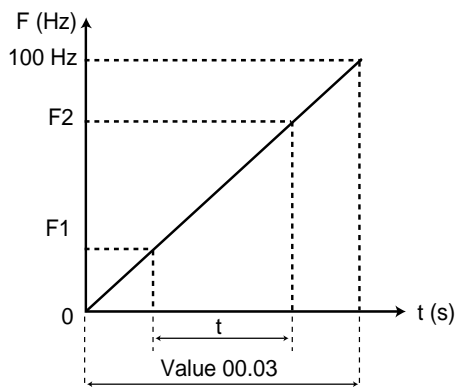

00.04 : Deceleration ramp

Range : 0 to 3200.0s/100Hz

Factory setting : 60.0s/100Hz

Increments of 0,1s.

Sets acceleration time from 100 Hz to 0.

$$\text{Value of 00.04 (s)} = \frac{t(\text{s}) \times 100\text{Hz}}{(F2-F1) \text{ min}^{-1}}$$

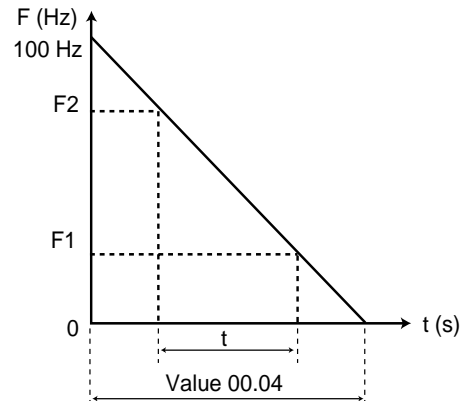

00.05 : Selection of speed references

Range : 0 to 5.

Factory setting : 0.

Increments of 1.

Used to choose speed reference.

0 : Selection of analogue reference 1 or preset frequencies.

1 : Analogue speed reference 1 - differential input - terminals 5 and 6.

2 : Analogue speed reference 2 - common mode input - terminals 7 and 11.

3 : Preset speeds (not available with menu 0).

4 : Selection of speed references from keypad.

5 : Precision speed references (not available with menu 0).

00.06 : Current limitation in motor and generator operating modes

Range : 0 to 120 % of I_n motor

Factory setting : 120 %

Increments of 1.

Sets maximum current supplied from the controller in motor and generator operating modes.

When current limit is reached, output frequency is automatically reduced.

00.07 : Selection of control mode

Range : 0 to 3.

Factory setting : 1.

Increments of 1.

0 : U_{rs} : Vector control mode, stator resistance measured for each run command of the controller.

1 : U_{r1} : Vector control mode, stator resistance measured for each power-up of the controller.

2 : U_r : Vector control mode, without stator resistance measurement.

3 : F_d : V to F mode with adjustable fixed boost.

⚠ In mode 1 (U_{r1}), at power-up, a voltage is briefly applied to the motor without any run command. For safety reasons, no electrical circuit should be accessible as soon as the controller is powered up.

Speed controller for asynchronous motors UMV 2301 AS

CAUTION :

During measurement of stator resistance, the motor must stand perfectly still. If stillness of motor cannot be guaranteed at each power-up of the controller, mode 1 may be used for the first power-up and then mode 2 should be used once the procedure has been completed.

Measurement of stator resistance allow optimization of the motor / controller unit performances.

00.08 : Starting torque (Boost)

Range : 0 to 25.0 % of Un motor (00.44).

Factory setting : 3 % of Un motor.

For operation in V to F mode, (00.07 at 3 : Fd) parameter 00.08 sets the starting torque. It is a percentage of motor rated voltage (00.44).

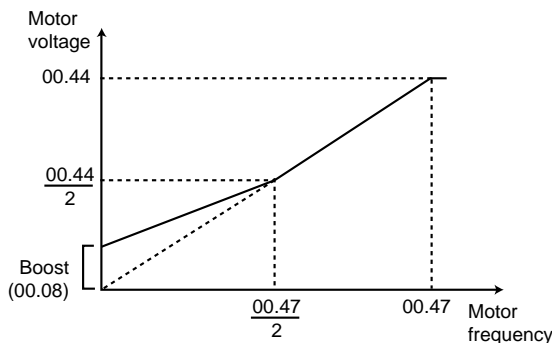

CAUTION :

If the set value is too high, the motor can become noisy and overheat.

00.09 : Selection of V to F dynamic mode

Range : 0 to 1.

Factory setting : 0.

0 : U/F ratio is fixed and set by basic frequency (00.47).

1 : U/F ratio is automatically adapted to motor load.

The voltage applied to the motor is reduced according to the load. It is thus possible to spare energy and reduce noise for low and variable loads.

00.10 : Measurement of motor speed

Range : -60.000 to +60.000 min⁻¹

Motor speed in min⁻¹. With standard setting, parameter 00.10 is displayed as soon as the controller is powered-up.

00.11 : Frequency reference before ramp

Range : -1000.0 to +1000.0Hz

Increments of 0,1 Hz.

Measurement of set frequency before ramp. Used for diagnosis.

00.12 : Frequency reference after ramp

Range : -1000.0 to +1000.0Hz

Increments of 0,1 Hz.

Measurement of set frequency after ramp. Used for diagnosis.

00.13 : Measurement of motor active current

Range : - I max to + I max contr.

The active current in the motor is the image of the torque in vector control mode.

00.14 : Measurement of total current

Range : 0 to I max contr.

Gives effective current in each output phase of the controller.

It corresponds to the vector sum of magnetizing current and active current.

00.15 : Selection of deceleration mode

Range : 0 to 2.

Factory setting : 2.

Increments of 1.

0 : Stnd Hd - Standard deceleration ramp with time delay to avoid overvoltage tripping of DC bus.

1 : FAST - Deceleration with fixed time up to current limit. With a driving load, a braking resistor option is necessary.

2 : Stnd Ct - Deceleration ramp with regulation of DC bus voltage and speed control, adapted for lightly loaded machines and permitting a smoother operation than with stnd.Hd setting.

Speed controller for asynchronous motors UMV 2301 AS

00.16 : Select stop mode

Range : 0 to 4.

Factory setting : 1 (rp).

0 (COAST) : Coast stop

The power bridge is deactivated when stop command is given. The controller cannot receive a new run command during 2s, corresponding to motor demagnetizing time. The display shows rdY 2s after run command. The machine stop time depends on its inertia.

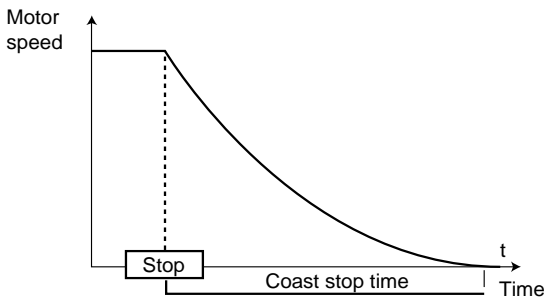

1 (rP) : Deceleration ramp stop

The controller decelerates the motor according to deceleration mode set with parameter 00.15. One second after stopping, the display shows rdY.

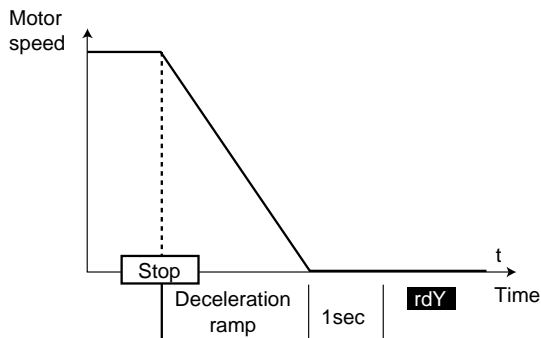

2 (rp.dcl) : Deceleration ramp stop with DC injection during 1s

The controller decelerates the motor according to the deceleration mode set with parameter 00.15. When zero frequency is reached, the controller injects DC in the motor during 1 second at a level specified by parameter 06.06. Then the display shows rdY.

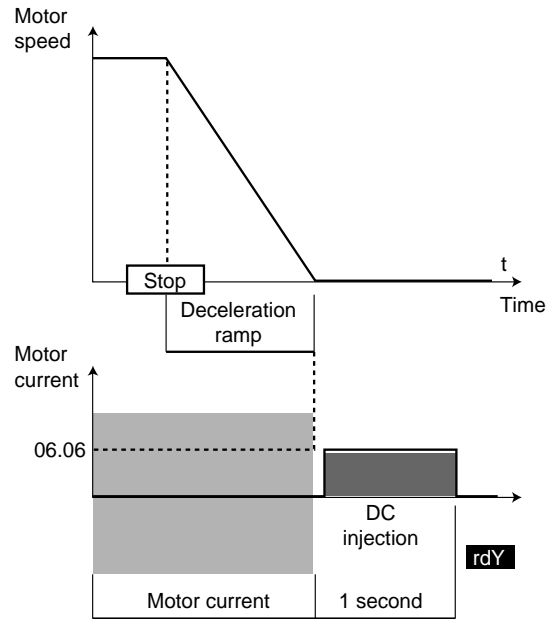

3 (dcl.DC) : Stop after DC injection braking, with zero speed detection

The controller decelerates the motor by injecting DC at a level specified by parameter 06.06 until it reaches a low speed which the controller automatically detects. The DC current is switched off 1 second after the motor has stopped. Then the controller display shows rdY.

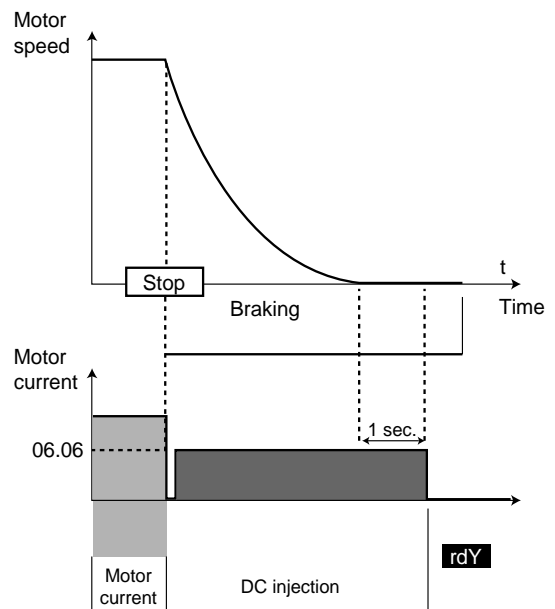

CAUTION :

For efficient braking, value of parameter 06.06 must be set at 60 % minimum.

Speed controller for asynchronous motors UMV 2301 AS

4 (td.dcl) : Timed DC injection braking stop

The controller decelerates the motor by injecting DC in the motor at a level specified by parameter 06.06 for a period set with parameter 06.07, then the controller display shows rdY. No run command can be registered as long as rdY is not displayed.

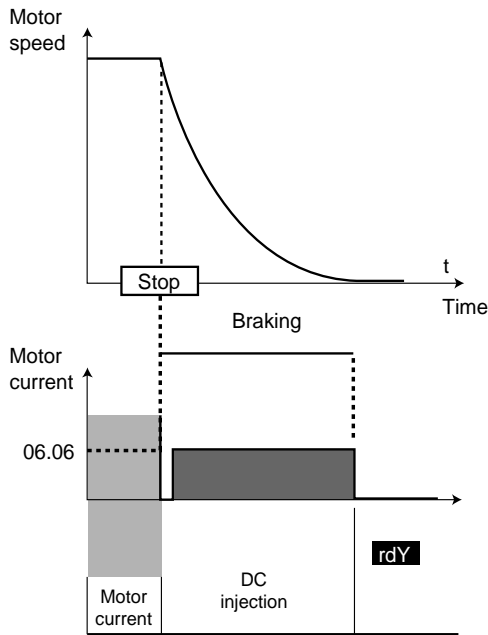

00.17 : Motor power

Range : $\pm (I \text{ max drive} \times 0.44 \times \sqrt{3}) / 1000$.

Unit : kW.

Measured active motor power.

00.18 : Selection of linear ramp / S ramp

Range : 0 to 1.

Factory setting : 0.

0 : The ramp is linear.

1 : A radius (defined in 00.19) at beginning and end of ramp avoids load balance.

00.19 : S ramp rate

Range : 0 to $3000.0s^2/100Hz$

Factory setting : $450.0 s^2$

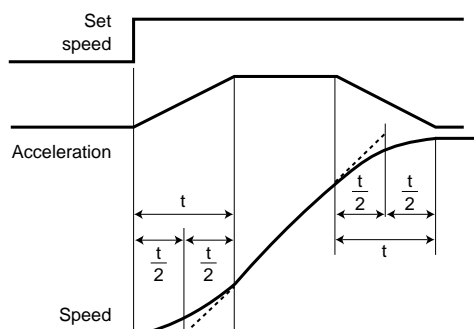

$t = (00.19) \div (00.03)$ for acceleration,
 $t = (00.19) \div (00.04)$ for deceleration.

The value of 00.19 sets the maximum acceleration and deceleration rate, from beginning to end of speed modification. Compared with a linear ramp, the S ramp increases the global value of t, (t/2 at the beginning and the end of the linear ramp).

00.20 : Frequency skip 1

00.22 : Frequency skip 2

Range : 0 to 1000.0 Hz

Factory setting : 0.0 Hz

Allows to eliminate one or two motor operating frequencies which may cause mechanical resonance. If set to 0 the function is not activated.

00.21 : Frequency skip band 1

00.23 : Frequency skip band 2

Range : 0 to 5,0 Hz

Factory setting : 0,5 Hz

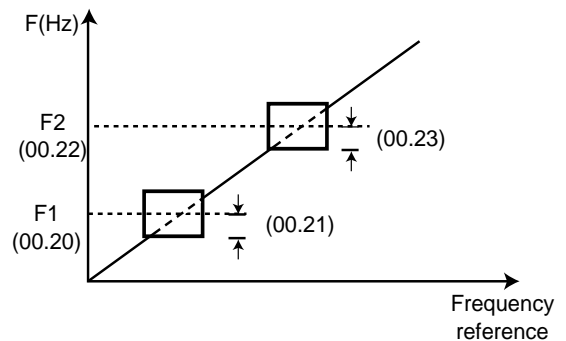

00.24 : Preset frequency 1

00.25 : Preset frequency 2

Range : 0 to ± 1000.0 Hz

Factory setting : 0.0 Hz

These parameters allow to preset 2 frequencies.

They can be used as references by commuting terminal 29 to 1.

Choice of preset frequency is achieved through terminal 26.

Status terminal 26	0	1
Reference	Preset frequency 1	Preset frequency 2

Speed controller for asynchronous motors

UMV 2301 AS

00.26 : DC bus regulation voltage threshold

Range : 0 to 800V

Factory setting : 700V

This threshold is used when the controller is configured in deceleration mode 0 (Std.Hd) or 2 (Std.Ct).

In mode 0, should this threshold be set too low, the deceleration ramp will not decrease and the machine will not stop. If this threshold is set too high and there are no resistances connected, the controller will trip due to DC bus overvoltage (OV).

In mode 0, should this threshold be set too low, the deceleration ramp will not decrease and the machine will stop in coast mode. If this threshold is set too high and there are no resistances connected, the controller will trip due to DC bus overvoltage (OV).

The minimum value of this parameter must be higher than DC bus voltage obtained with maximum mains voltage. ($V_{bus} = V_{mains} \sqrt{2}$).

00.27 : Current loop proportional gain

00.28 : Current loop integral gain

Range : 0 to 4000

Factory setting : 00.27 = 20

00.28 = 40

According to various internal factors of the controller, some oscillations may occur in the following situations :

- Frequency regulation with current limitation around rated frequency and with load impacts.
- Torque regulation on lightly loaded machines and around rated speed.
- Cutout of mains supply or on controlled deceleration ramp when DC bus regulation is functioning

To reduce these oscillations, it is recommended :

- first to increase proportional gain (00.27),
- then to reduce integral gain (00.28).

00.29 : DC bus voltage

Range : 0 to 830

Gives measurement of DC bus voltage.

00.30 : Stator resistance

Range : 0 to 32.000 Ω

Factory setting : 0.000 Ω

This parameter memorizes motor stator resistance in vector mode. It is measured according to mode selected with parameter 00.07.

00.31 : Type of signal on analogue input 1

Range : 0 to 8

Factory setting : 0

The signal of analogue input 1 (terminals 5 and 6) can be processed in different ways.

0 (Volt) : Voltage input $\pm 10V$.

1 (0-20) : Current input 0 - 20mA.

2 (20-0) : Current input 20 - 0mA.

3 (4-20.tr) : Current input 4 - 20mA with tripping on signal loss.

4 (20-4.tr) : Current input 20 - 4mA with tripping on signal loss.

5 (4-20.Lo) : Current input 4 - 20mA with setting at minimum speed reference on signal loss.

6 (20-4.Lo) : Current input 20 - 4mA with setting at minimum speed reference on signal loss.

7 (4-20.Pr) : Current input 4 - 20mA with keeping of reference before tripping on signal loss.

8 (20-4.Pr) : Current input 20 - 4mA with keeping of reference before tripping on signal loss.

Note : For the modes 4 - 20mA and 20 - 4 mA, signal loss threshold is 3mA.

00.32 : Software version 2

Range : 1 to 99

Indicates the third digit of software version installed in the controller.

Changes according to software modifications which does not affect the user.

00.33 : Controller rated current

Range : 12.0 to 180.0 A

Factory setting : according to controller rating

This parameter indicates controller rated voltage in permanent operating mode.

00.34 : User security code

Range : 0 to 255

Factory setting : 149

It is possible with this parameter to enter a personal security code which forbids any parameter modification.

The personal code can only be read when it is edited. In all other cases code 149 will be displayed.

Do not use code 0.

Access to the parameters is achieved by entering selected personal code in parameter 0.00.

00.35 : Serial link, "2-wire" mode

Range : 0 or 1

Factory setting : 0

0 : 4-wire standard mode

1 : As used ANSI protocol is of " half duplex " type, it is possible to connect Rx and Tx as well as RX and TX together and thus operate the serial link with only 2 data connections.

00.36 : Serial link transmission rate

Range : 4800 Bauds, 9600 Bauds,

19200 Bauds

Factory setting : 4800 Bauds

Speed controller for asynchronous motors UMV 2301 AS

00.37 : Controller serial link address

Range : 0 to 9,9
Factory setting : 1,1

When an optional communication card " COM 1 UMV " is used, 00.37 specifies a controller address. The address must have the following format : 1.1 to 9.9.
Do not use 0 as a group or controller address.

00.38 : Parameter displayed on power-up

Range : 0 to 00.50
Factory setting : 00.10
Defines which parameter is displayed when the controller is powered up.
0.10 corresponds to motor speed.

00.39 : Enable catch spinning motor

Range : 0 or 1
Factory setting : 1

0 : no catch spinning motor restart after fugitive cut-out.
1 : **catch spinning motor. After a fugitive cut-out of the mains, the controller measures the frequency of the remanent motor voltage in order to determine its rotating speed. Thus the controller automatically readjusts speed reference to actual motor speed.**

 • If the load stands still when run command is given or when mains supply is restored, this operation can cause an unwanted rotation of the machine before the motor accelerates.
• Make sure this function does not affect safety of personnel and machinery.

00.40 : Self-calibration

Range : 0 to 1.
Factory setting : 0.
1 : When started up for the first time, allows measurement of motor data (magnetizing current, cos φ , etc...).
This operation must be carried out with the motor unloaded. The controller accelerates the motor up to 50% of rated speed and then stops.

 • During the self-calibration phase, the controller powers the motor thus causing it to rotate. Make sure this operation does not affect safety.

00.41 : Switching frequency

Range : 3 - 4,5 - 6 - 9 - 12 kHz
Factory setting : 3 kHz
00.41 sets the PWM switching frequency as well as the sampling frequencies of the analogue and digital inputs according to the following table :

Setting	Display kHz	Switching frequency	
		Condition A kHz	Condition B kHz
0	3	3	3
1	4,5	4,5	2,2
2	6	6	3
3	9	4,5	2,25
4	12	6	3

Switching frequencies of digital and analogue inputs

- Condition A :
- operation with frequency control.
- Condition B :
- operation with analogue input control by current signal.

 Depending on switching frequency and rating of the UMV 2301 AS controller, it is necessary to derate output current. Refer to table § 1.3.2.

00.42 : Motor polarity

Range : 2 to 24 poles.
Factory setting : 4 poles
Increments of 2.

Motor pole number	Motor rated speed (min ⁻¹)
2	3000
4	1500
6	1000
8	750

00.43 : Motor rated power factor (cos φ)

Range : 0 to 1,000
Factory setting : 0,85
Increments of 0,01.
The cos φ value is automatically measured during self-calibration phase and set with the present parameter.

00.44 : Motor rated voltage

Range : 0 to 480V
Factory setting : 400V
Corresponds to rated voltage stamped on motor nameplate. Setting of the V to F rate.

00.45 : Motor rated speed

Range : 0 to 6000.0 min⁻¹
Factory setting : 0
Increments of 1.
Corresponds to motor speed under load for open loop operation (see nameplate).

CAUTION :

In certain situations and especially with very high inertial loads, a speed instability may occur around 20 Hz. If this is the case, leave rated speed at 0.

Speed controller for asynchronous motors UMV 2301 AS

00.46 : Motor rated current

Range : 0 to In controller

Factory setting : In controller

Corresponds to current value stamped on motor nameplate. Overload starts from this value.

00.47 : Motor rated frequency

Range : 0 to 1000.0 Hz

Factory setting : 50 Hz

Increments of 0,1 Hz.

Corresponds to the point where the motor operating mode switches from constant torque to constant power.

In standard operating mode, it corresponds to the frequency stamped on motor nameplate.

00.48 : Selection of operating mode

Factory setting : HVAC

HVAC : Open loop operation in vector control mode or in V to F mode.

00.49 : Security status

Factory setting : 001

Parameter 00.49 is composed of 3 digits and determinates parameter protection level.

X	X	X
Code personalized with 00.34 0 : No 1 : Yes	Personnalized code enabled. No modification of parameters is possible 0 : No 1 : Yes	Access to other menus with code 149 0 : No 1 : Yes

00.50 : Software version 1

Range : 1.00 to 9.99

Indicates the 2 first digits of the software version installed in the controller.

Speed controller for asynchronous motors UMV 2301 AS

4.4 - Fault processing

The controller has been factory configured for the most secure operation :

- memorization of all faults,
- fault clearance by voluntary action,
- controlled start.

However, depending on the application and on operating conditions, it is possible to control the operation as per the table hereunder.

Parameter	Function	Setting	Description	Factory setting
06.02	Start mode	diS	The start is controlled. If run command is present at power-up, it will be necessary to perform stop command and then run in order to obtain the start	diS
		ALYS	At power-up, start is automatic if the controller has not tripped and if run command is present	
		Pd.dP	At power-up, the controller will automatically start if the drive was running when the power supply was cut out, and if run command is present. On the other hand, it will not start if it was stopped when the power cut-out occurred.	
06.03	Processing of microcuts	diS	When a microcut occurs, the controller keeps on driving as long as the DC bus voltage is sufficient	diS
		StoP	The controller detects the microcut and decelerates in order to recover motor energy and thus maintain the DC bus voltage. When normal operating conditions are restored, deceleration continues until the motor stops.	
		ridE.th	As before, but when normal conditions are restored, the motor reaccelerates up to set speed.	
06.09	Catch spinning motor	bit 0	When starting or after a microcut, the controller starts its ramp from 0.	1
		1	The controller measures the frequency of the remanent voltage in order to determine motor rotation speed and direction and adjusts its reference to the measured value.  • if the motor is stopped, this function can cause unexpected rotation of the motor for a period of 1 or 2 seconds.	
10.34	Number of automatic reset	0	After tripping, the controller waits for a clearance before starting again.	0
		1 to 5	After tripping, the controller tries automatically to re-start as many times as the programmed number. If the number of restartings has been completed within a 5 minute interval, the controller is locked.	
10.35	Automatic restart time delay	0 to 25s	Delay between a tripping and an automatic re-start.	1
10.36	Processing of fault relay	bit 0	The fault relay gets to 0 between the fault occurrence and the automatic restarting.	0
		bit 1	The fault relay remains at 1 between the fault occurrence and the automatic restarting.	
10.37	Stop mode for minor faults	bit 0	The controller initiates a coast stop for every fault.	0
		bit 1	When a minor fault occurs (fault 14 to 26 paragraph 5), the controller decelerates before locking.	

**Speed controller for
asynchronous motors
UMV 2301 AS**

Notes

Speed controller for asynchronous motors UMV 2301 AS

4.5 - Other menus

In most cases, commissioning of the controller is possible with menu 0 or with the parameter settings given in specific diagrams. However, for particular applications, it could be interesting to have access to all the parameters of the controller. These are grouped in menus and are expressed either in tables or in logic diagrams.

4.5.1 - MENU 1 : FREQUENCY REFERENCE : Selection, limitations and filters

4.5.1.1 - Parameter list, Menu 1

Parameters also available in menu 0

Parameter	Description	Type	Adjustment range	Unit	Factory setting	User setting
01.01	Frequency reference before clamps	RO	±1000,0	Hz	-	-
01.02	Frequency reference before frequency skip	RO	± min frequency to ± max frequency	Hz	-	-
01.03	Frequency reference before ramp	RO	± min frequency to ± max frequency	Hz	-	-
01.04	Frequency reference offset	R-W	±1000,0	Hz	0	
01.05	Jog reference	R-W	0 - 400,0	Hz	1,5	
01.06	Maximum frequency clamp	R-W	0-1000,0	Hz	50,0	
01.07	Minimum frequency clamp	R-W	0 to ± 01.06	Hz	0	
01.08	Select negative minimum frequency	R-W	0 or 1	-	0	
01.09	Select frequency reference offset	R-W	0 or 1	-	0	
01.10	Select bipolar mode	R-W	0 or 1	-	0	
01.11	Run command flag	RO	0 or 1	-	-	-
01.12	Running direction flag	RO	0 or 1	-	-	-
01.13	Jog flag	RO	0 or 1	-	-	-
01.14	Select frequency references	R-W	0 - 5	Code	0	
01.15	Select preset frequencies	R-W	0 - 9	Code	0	
01.16	Preset reference timer	R-W	0 - 400,0	s	10,0s	
01.17	Keypad reference	R-W	Min limit to max limit	-	0	
01.18	Precision reference (integral value)	R-W	±1000,0	Hz	0,0	
01.19	Precision reference (decimals)	R-W	0,099	Hz	0,000	
01.20	Enable precision reference	R-W	0 or 1	-	0	
01.21	Preset frequency 1	R-W	±1000,0	Hz	0	
01.22	Preset frequency 2	R-W	±1000,0	Hz	0	
01.23	Preset frequency 3	R-W	±1000,0	Hz	0	
01.24	Preset frequency 4	R-W	±1000,0	Hz	0	
01.25	Preset frequency 5	R-W	±1000,0	Hz	0	
01.26	Preset frequency 6	R-W	±1000,0	Hz	0	
01.27	Preset frequency 7	R-W	±1000,0	Hz	0	
01.28	Preset frequency 8	R-W	±1000,0	Hz	0	
01.29	Frequency skip 1	R-W	0-1000,0	Hz	0	
01.30	Frequency skip band 1	R-W	0-5,0	Hz	0,5	
01.31	Frequency skip 2	R-W	0-1000	Hz	0	
01.32	Frequency skip band 2	R-W	0-5,0	Hz	0,5	
01.33	Frequency skip 3	R-W	0-1000,0	Hz	0	
01.34	Frequency skip band 3	R-W	0-5,0	Hz	0,5	
01.35	Frequency skip band flag	RO	0 or 1	-	-	-
01.36	Analogue frequency reference 1	R-A	±01.06 or -01.07 to +01.06	Hz	-	-
01.37	Analogue frequency reference 2	R-A	±01.06 or -01.07 to +01.06	Hz	-	-
01.38	Frequency reference percentage trim	R-A	± 100,0	%	-	-
01.41	Select reference via logic inputs	R-A	0 or 1	-	-	-
01.42	Select reference via logic inputs	R-A	0 or 1	-	-	-
01.43	Select reference via logic inputs	R-A	0 or 1	-	-	-
01.44	Select reference via logic inputs	R-A	0 or 1	-	-	-
01.45	Select reference via logic inputs	R-A	0 or 1	-	-	-
01.46	Select reference via logic inputs	R-A	0 or 1	-	-	-
01.47	Select reference via logic inputs	R-A	0 or 1	-	-	-
01.48	Timer reset flag	R-W	0 or 1	-	0	-
01.49	Selected reference indicator	RO	1 - 5	Code	-	-
01.50	Selected preset reference indicator	RO	1 - 8	Code	-	-

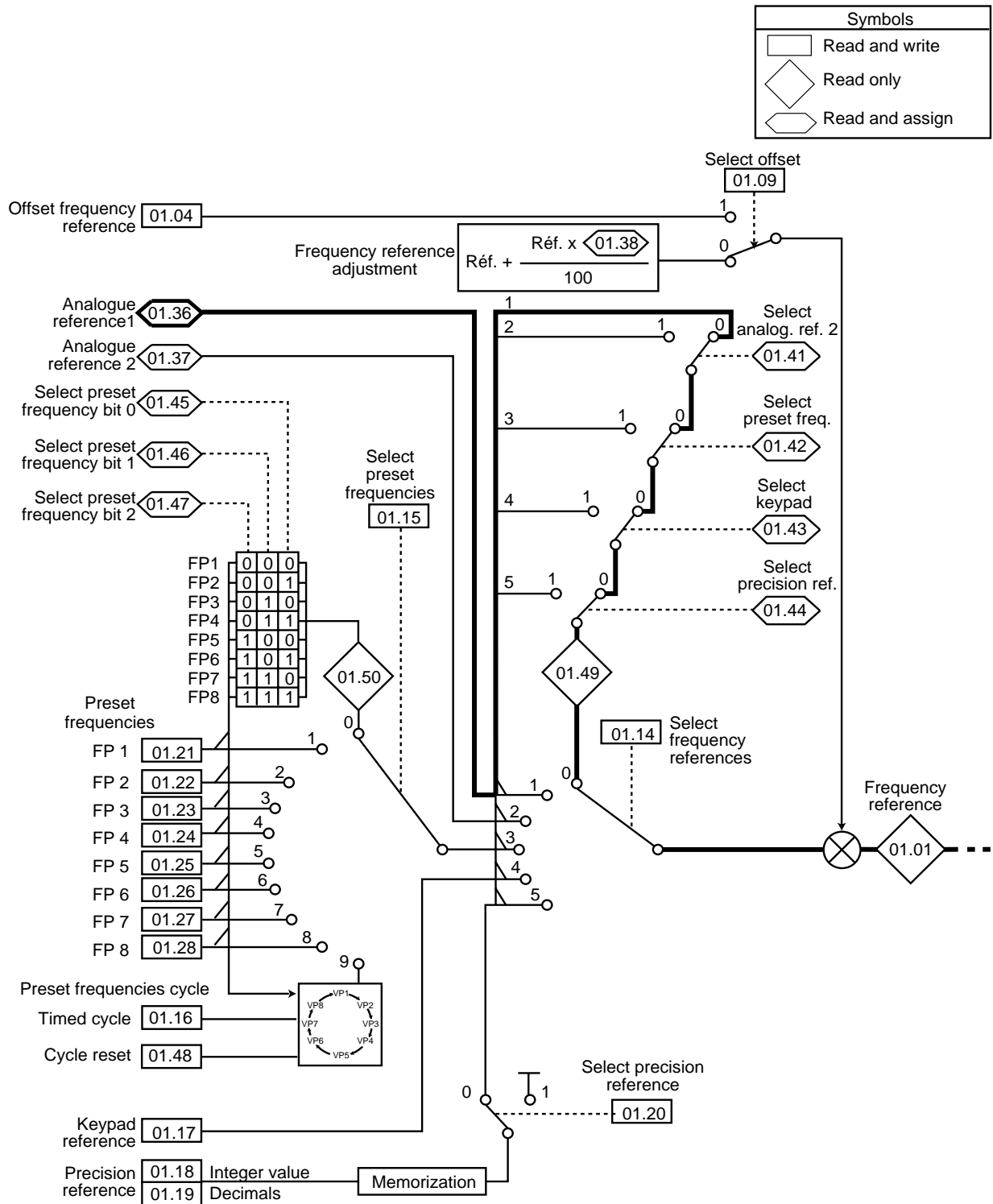

Speed controller for asynchronous motors UMV 2301 AS

4.5.1.2 - Block diagrams, Menu 1 Selection of frequency reference



Speed controller for asynchronous motors UMV 2301 AS

Limitations and filters

Symbols	
	Read and write
	Read only
	Read and assign

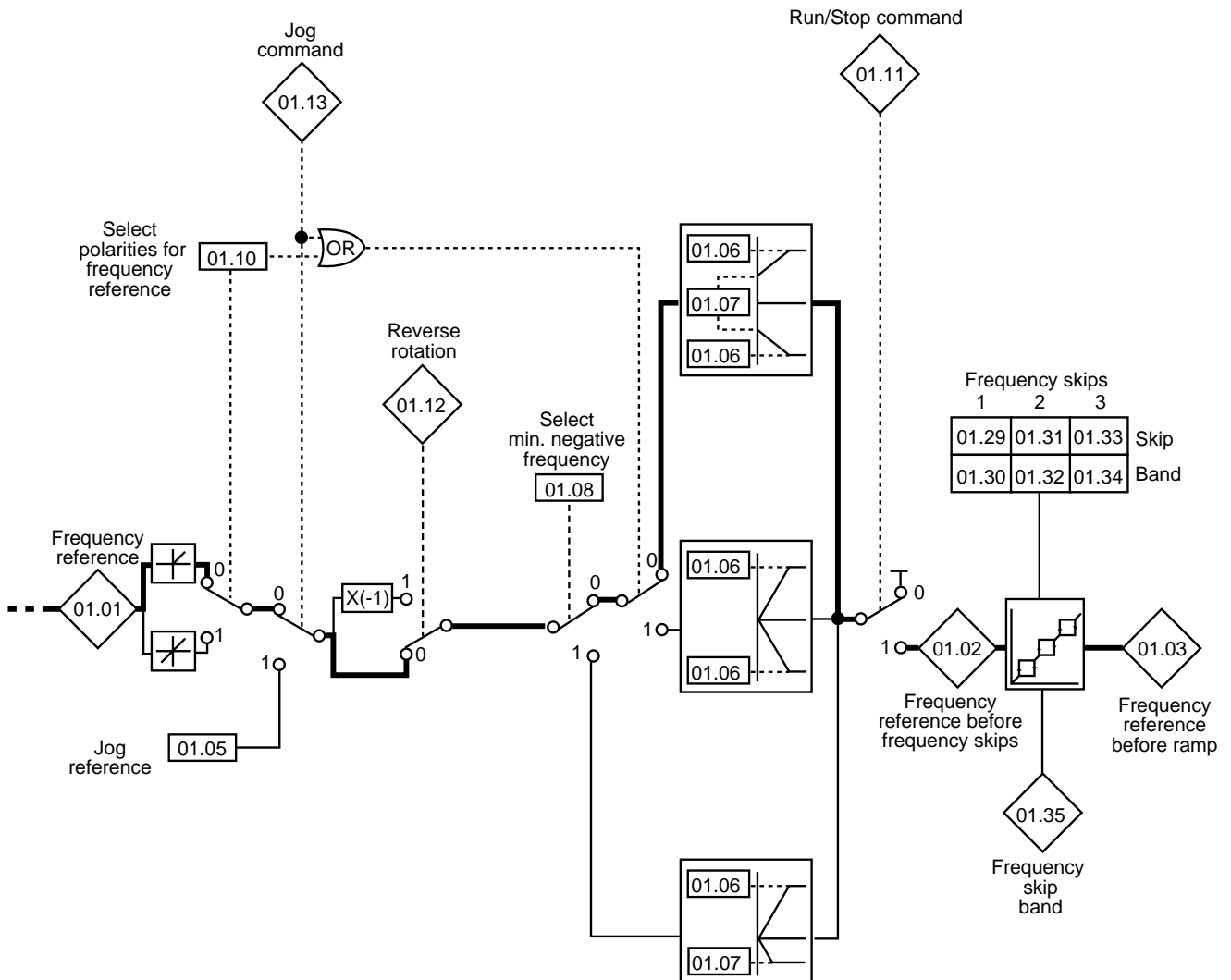



Speed controller for asynchronous motors UMV 2301 AS

4.5.1.3 - Description of parameters in menu 1

 **01.01** : Frequency reference before clamps

Range : $\pm 1000,0$
Sets the value of frequency reference.

 **01.02** &  **01.03** : Frequency reference before ramp

Range : \pm min frequency to \pm max frequency

01.02 : frequency reference after clamps but before frequency skips.

01.03 : frequency reference after frequency skips but before acceleration or deceleration ramps.

 **01.04** : Frequency reference offset

Range : $\pm 1000,0$ Hz
Factory setting : 0 Hz
This reference is added to selected reference if parameter 01.09 is set to 1. It can be used to adjust selected main reference in order to have a precise setting.

 **01.05** : Jog reference

Range : 0 - 400,0 Hz
Factory setting : 1,5 Hz
Frequency reference used for jogging.

 **01.06** : Maximum frequency clamp

Range : 0 - 1000,0 Hz
Factory setting : 50,0 Hz
If parameter 01.08 is set to 0, this parameter sets the maximum frequency in both running directions.
If parameter 01.08 is set to 1 it is the maximum frequency in forward operation only.
Sets maximum frequency. Slip compensation can increase the output frequency further.

 **01.07** : Minimum frequency clamp

Range : If 01.08 = 0 : 0 to 01.06
If 01.08 = 1 : 0 to -1000 Hz
Factory setting : 0 Hz
If parameter 01.08 is set to 0, this parameter sets the minimum frequency in unipolar mode.
Inactive parameter when operating in jog mode or bipolar mode.
If parameter 01.08 is set to 1, this parameter sets the negative minimum frequency in reverse operation.

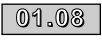
 **01.08** : Select negative minimum frequency

Range : 0 or 1
Factory setting : 0

0 : minimum frequency (01.07) can be between 0 and the maximum clamp. In this case, the reference variation range will be between 01.07 and 01.06 in forward operation and -01.07 and -01.06 in reverse operation.

CAUTION : Operation in jog mode or bipolar mode disables the minimum clamp.



1 : parameter 01.07 is used as maximum limit in reverse operation. The reference variation range is thus 01.07 in reverse operation and 01.06 in forward operation.

 **01.09** : Select frequency reference offset

Range : 0 or 1
Factory setting : 0
0 : the frequency reference offset added to selected reference corresponds to the percentage trim specified by parameter 01.38.
1 : the offset has the value of reference offset (01.04).

 **01.10** : Select bipolar mode

Range : 0 ou 1
Factory setting : 0
0 : all negative references are treated as zero.
1 : allows to change running direction through reference polarity.

 **01.11** to  **01.13** : Drive control flags

Range : 0 or 1
These flags allow to control the enabling of run commands.

01.11 : 0 = Stop
1 = Run
01.12 : 0 = Run forward
1 = Run reverse
01.13 : 1 = Enable jog operation.

Speed controller for asynchronous motors UMV 2301 AS

01.14 : Select frequency references

Range : 0 - 5

Factory setting : 0

This parameter is used to select frequency reference as follows :

0 : Select reference by logic terminal inputs

- 1 : Analogue reference 1 selected
- 2 : Analogue reference 2 selected
- 3 : Preset frequencies selected
- 4 : Keypad reference selected
- 5 : Precision reference selected

When this parameter is set to 0, the considered reference depends on the state of bit parameters 01.41 to 01.44.

01.41 : Select analogue reference 2

01.42 : Select preset frequencies

01.43 : Select keypad reference

01.44 : Select precision reference

- If all these parameters are set to 0, analogue reference 1 will be selected.

- If at least one of these parameters is set to 1, the highest parameter will have priority.

01.15 : Select preset frequencies

Range : 0 - 9

Factory setting : 0

This parameter is used to select preset frequencies. It works as follows :

0 : Select preset frequencies by logic terminal inputs

- 1 : Preset frequency 1 selected
- 2 : Preset frequency 2 selected
- 3 : Preset frequency 3 selected
- 4 : Preset frequency 4 selected
- 5 : Preset frequency 5 selected
- 6 : Preset frequency 6 selected
- 7 : Preset frequency 7 selected
- 8 : Preset frequency 8 selected
- 9 : Preset frequencies automatically selected by timer

When this parameter is set to 0, requested preset frequency is selected according to state of bit parameters 01.45 to 01.47.

Selection operates according to the table below.

01.45	01.46	01.47	Selected preset frequency
0	0	0	1
1	0	0	2
0	1	0	3
1	1	0	4
0	0	1	5
1	0	1	6
0	1	1	7
1	1	1	8

When this parameter is set to 9, the controller automatically selects in turn FP1 --> FP2 ----- FP7 --> FP8 --> FP1 ----- . Parameter 01.16 allows setting of switching time from a frequency to another.

01.16 : Preset frequencies reference timer

Range : 0 - 400,0s

Factory setting : 10,0s

When an automatic cycle is selected (01.15 = 9), this parameter sets switching time from a preset frequency to another. When parameter 01.48 gets to 1, the cycle system is reset to 0 and preset frequency 1 is selected.

01.17 : Reference setting via keypad

Range :

01.08	01.10	Range
0	0	01.07 to 01.06 (01.07 > 0)
0	1	± 01.06
1	0	0 to 01.06
1	1	01.07 to 01.06 (01.07 ≤ 0)

Factory setting : 0

This parameter is used to adjust the reference when setting via keypad is selected (01.14 = 4). Key D is used to increase the reference and key E to decrease it.

The speed reference value is saved on power down so it is automatically reset when the drive is powered-up again.

01.18 , 01.19 : Precision reference

Range : 01.18 : ± 1000,0 Hz

01.19 : 0 - 0.099 Hz

Factory setting : 01.18 : 0,0 Hz

01.19 : 0,000 Hz

As standard, the frequency reference cannot have a resolution better than 0,03 Hz. The use of the precision reference allows to reach a resolution of 0,001 Hz. In that case 01.18 allows to set the integral value of the reference, and 01.19 the decimals.

01.20 : Enable precision reference

Range : 0 or 1

Factory setting : 0

As the precision reference is set with 2 parameters, 01.20 is used to prevent the drive reading the parameters while the reference is being updated.

0 : The precision reference is stored in a memory.

1 : The precision reference is enabled.

01.21 to 01.28 : Preset frequencies

Range : ± 1000,0 Hz

Factory setting : 0 Hz

In that order, 01.21 to 01.28 are used to adjust preset frequencies FP1 to FP8.

Speed controller for asynchronous motors UMV 2301 AS

01.29 , **01.31** : Frequency skips

01.33

Range : 0 - 1000,0 Hz

Factory setting : 0 Hz

Three frequency skips are available to prevent operation at critical speeds that would cause mechanical resonance of the machine. When a parameter is set to 0, the function is inactive.

01.30 , **01.32** : Frequency skip bands

01.34

Range : 0 - 5,0 Hz

Factory setting : 0,5 Hz

These parameters set the frequency range around the avoided frequency. The total frequency skip is thus equal to the set threshold \pm skip band.

01.35 : Frequency skip band flag

Range : 0 or 1

This parameter is set to 1 when the selected reference is within one of the frequency skip regions.

In that case motor speed does not correspond to demanded reference.

01.36

01.37 : Analogue references 1 and 2

Range : 01.08 = 0 : \pm 01.06 Hz

01.08 = 1 : - 01.07 to +01.06 Hz

The analogue inputs assigned to these parameters are automatically scaled so that 100,0 % of the input corresponds to the maximal set frequency. Likewise 0 % will correspond to the minimal reference (01.07).

Unipolar mode (01.10 = 0)

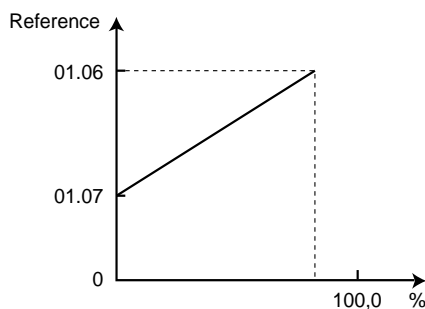

Bipolar mode (01.10 = 1)

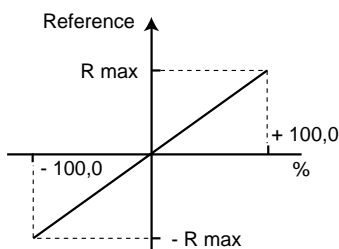

01.08 = 0, R max = 01.06.

01.08 = 1, R max = 01.06 or 01.07 which ever is greater.

01.38 : Frequency reference percentage trim

Range : \pm 100,0 %

An offset proportional to selected reference can be added to this reference. The trim factor depends on the analogue input routed to parameter 01.38.

Final ref (01.01) = selected ref \times $(1 + \frac{01.38}{100})$.

01.41 to **01.47** : Select reference via logic inputs

Range : 0 or 1

These parameters are used to control selection of the reference via logic inputs (see parameters 01.14 and 01.15)

01.41 : Select analogue reference 2

01.42 : Select preset frequencies

01.43 : Select reference via keypad

01.44 : Select precision reference

01.45 : Select bit 0 preset frequencies

01.46 : Select bit 1 preset frequencies

01.47 : Select bit 2 preset frequencies

01.48 : Timer reset flag

Range : 0 or 1

Factory setting : 0

When this parameter is set to 1, the preset frequency timer is reset to 0 (01.15 = 9), such that preset frequency 1 is selected. This parameter can be used to start a new sequence of speed selection via programmable logic input.

01.49 : Selected reference indicator

Range : 1 - 5

Shows which reference is currently being selected.

01.50 : Selected preset reference indicator

Range : 1 - 8

Shows which preset reference is currently being selected.

Speed controller for asynchronous motors UMV 2301 AS

4.5.2 - MENU 6 : PROCESSING OF LOGIC COMMANDS AND METERS

4.5.2.1 - List over parameters in Menu 6

Parameters also available in menu 0

Parameter	Description	Type	Adjustment range	Unit	Factory setting	User setting
06.01	Select stop mode	R-W	0 to 4	Code	1	
06.02	Automatic start mode	R-W	0 to 2	Code	0	
06.03	Mains loss mode	R-W	0 to 2	Code	0	
06.04	Assignment and processing of logic commands	R-W	0 to 4	Code	4	
06.05	Minimum jog time	R-W	0,0 to 25,0	s	1	
06.06	DC injection braking level	R-W	0,0 to max current limit	%	100,0	
06.07	DC injection braking time	R-W	0,0 to 25,0	s	5,0	
06.08	Hold zero speed	R-W	0 or 1	-	0	
06.09	Enable catch spinning motor	R-W	0 or 1	-	0	
06.10	Spinning motor ramp rate	R-W	0 to 25,0	s/100 Hz	5,0	
06.11	Enable keypad Run key	R-W	0 or 1	-	0	
06.12	Enable keypad Stop key	R-W	0 or 1	-	0	
06.13	Enable keypad Forward / Reverse key	R-W	0 or 1	-	0	
06.14	Disable automatic selection of keys	R-W	0 or 1	-	0	
06.15	Drive enable	R-W	0 or 1	-	1	
06.16	kWh cost	R-W	0,0 to 300,00	currency / kWh	0	
06.17	Reset power meter	R-W	0 or 1	-	0	
06.18	Running time before alarm 1	R-W	0 to 30000	h	0	
06.19	Alarm 1 and meter reset	R-W	0 or 1	-	0	
06.20	Running time before alarm 2	R-W	0 to 30000	h	0	
06.21	Alarm 2 and meter reset	R-W	0 or 1	-	0	
06.22	Time counter (years and days)	RO	0,000 to 30,365	Years/days	-	-
06.23	Time counter (hours and minutes)	RO	0,00 to 23,59	h / mn	-	-
06.24	Power meter (MWh)	RO	0 to 30000	MWh	-	-
06.25	Power meter (kWh)	RO	0,0 to 999,9	kWh	-	-
06.26	Running cost	RO	0,00 to 300,00	currency / hour	-	-
06.27	Time before alarm 1	RO	0 to 30000	h	-	-
06.28	Time before alarm 2	RO	0 to 30000	h	-	-
06.29	Hardware enable	RO	0 or 1	-	-	-
06.30	Sequencing bit 0 logic commands	R-A	0 or 1	-	0	
06.31	Sequencing bit 1 logic commands	R-A	0 or 1	-	0	
06.32	Sequencing bit 2 logic commands	R-A	0 or 1	-	0	
06.33	Sequencing bit 3 logic commands	R-A	0 or 1	-	0	
06.34	Assignment of Run / Stop terminal	R-A	0 or 1	-	0	
06.35	Forward limit switch input	R-A	0 or 1	-	-	-
06.36	Reverse limit switch input	R-A	0 or 1	-	-	-
06.37	Spinning motor start voltage	R-W	0 to 100,0	% of rated voltage	25,0	
06.38	Spinning motor voltage ramp	R-W	0 to 2,50	s	0,25	

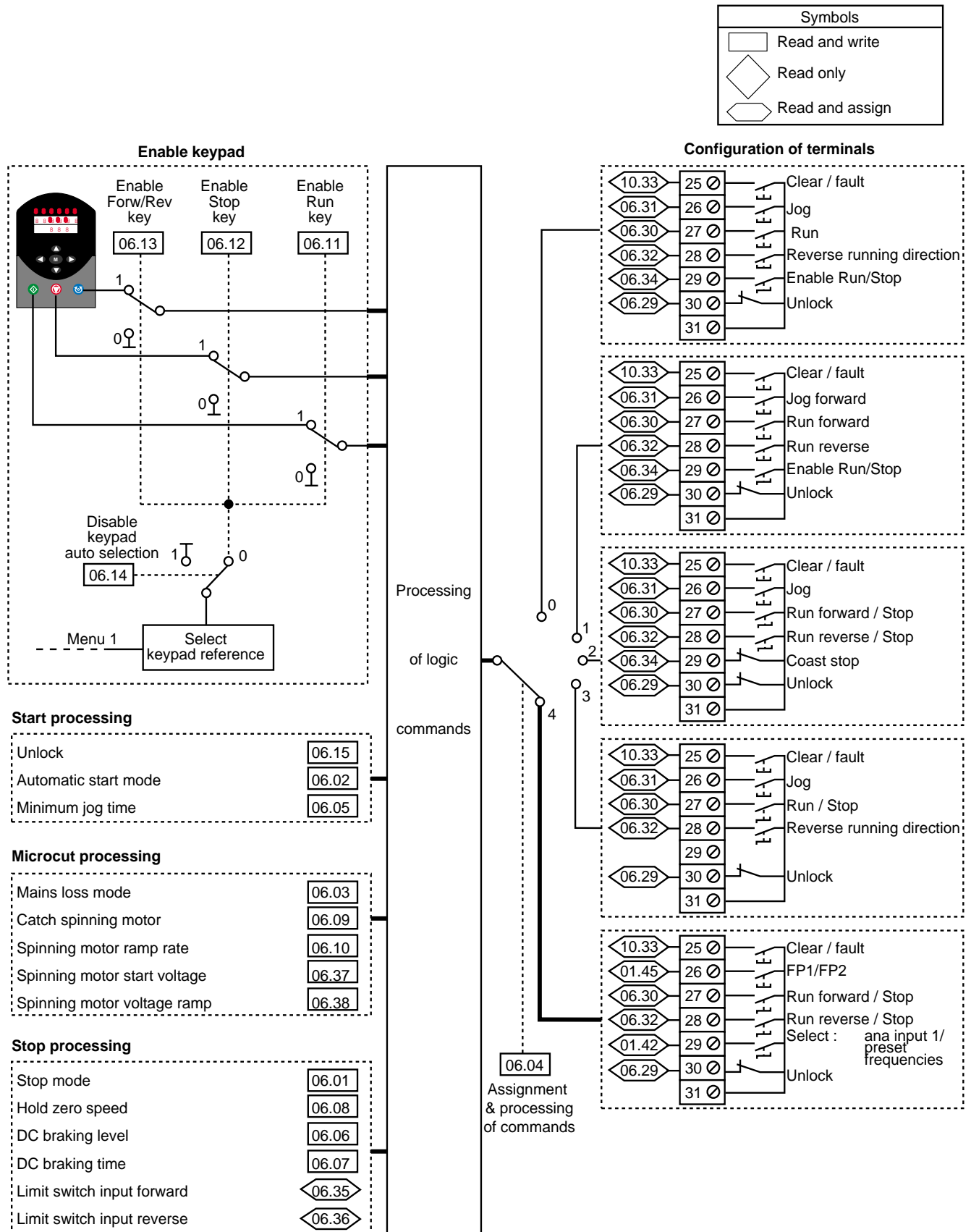

Speed controller for asynchronous motors UMV 2301 AS

4.5.2.2 - Block diagrams Menu 6 Processing of logic commands



Speed controller for asynchronous motors UMV 2301 AS

Time counter, power meter and alarms

Symbols	
	Read and write
	Read only
	Read and assign

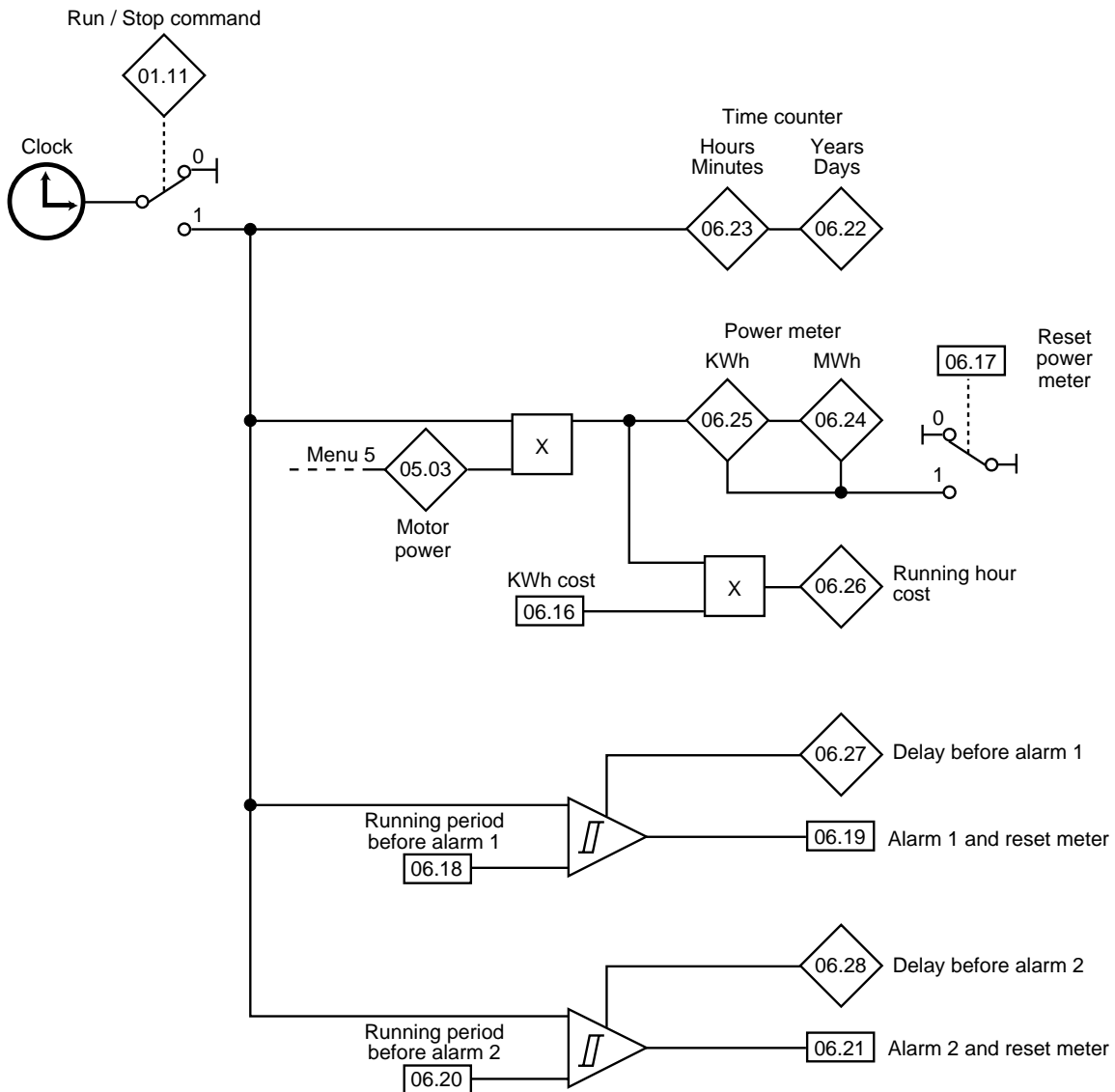

Speed controller for asynchronous motors UMV 2301 AS

4.5.2.3 - Description of parameters in menu 6

06.01 : Select stop mode

Range : 0 to 4.

Factory setting : 1 (rp).

0 (COAST) : Coast stop

The power bridge is deactivated when stop command is given. The controller cannot receive a new run command during 2s, corresponding to motor demagnetizing time. The display shows rdY 2s after run command. The machine stop time depends on its inertia.

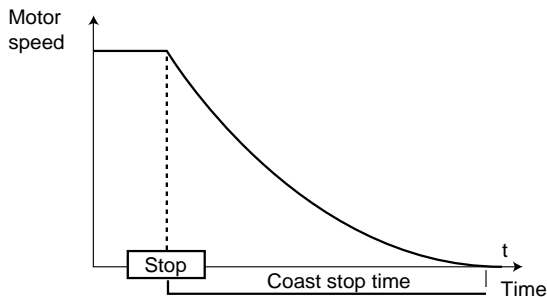

1 (rP) : Deceleration ramp stop

The controller decelerates the motor according to deceleration mode set with parameter 00.15. One second after stopping, the display shows rdY.

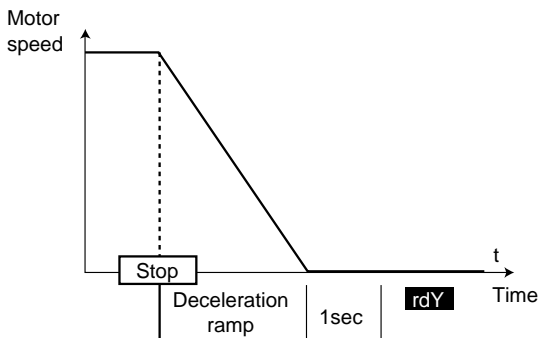

2 (rp.dcl) : Deceleration ramp stop with 1 second DC injection

The controller decelerates the motor according to the deceleration mode set with parameter 00.15. When zero frequency is reached, the controller injects DC in the motor during 1 second at a level specified by parameter 06.06. Then the display shows rdY.

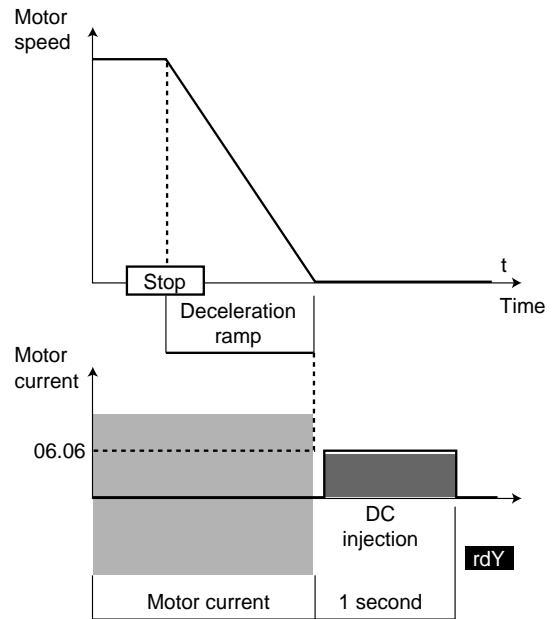

3 (dcl.DC) : DC injection braking stop with detection of zero speed

The controller decelerates the motor by injecting DC at a level specified by parameter 06.06 until it reaches a low speed which the controller detects automatically. The DC current is switched off 1 second after the motor has stopped. Then the controller display shows rdY.

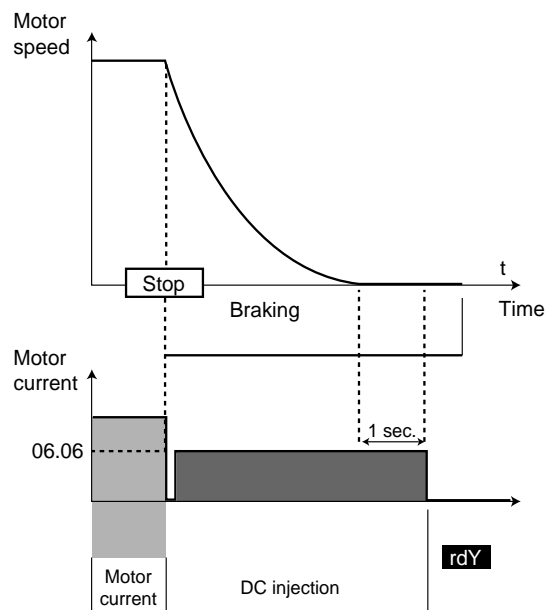

CAUTION :

For efficient braking, value of parameter 06.06 must be set to 60 % minimum.

Speed controller for asynchronous motors UMV 2301 AS

4 (td.dcl) : Stop after DC injection braking with fixed time
The controller decelerates the motor by injecting DC at a level specified by parameter 06.06 for a period set with parameter 06.07, then the controller display shows rdY. No run command can be registered as long as rdY is not displayed.

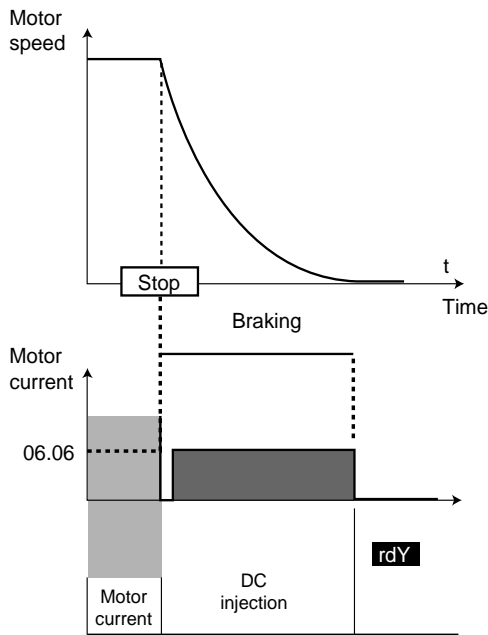

06.02 : Automatic start mode

Range : 0 to 2

Factory setting : 0

This parameter can be set to the 3 following values :

0	diS	When changing status
1	ALYS	Automatically at power-up
2	PddP	According to status when powered down

0 (diS) : Start is commanded. If the run command is present at power-up, it will be necessary to command Stop and then Run to start the drive.

1 (ALYS) : Start is automatic at power-up if the controller is not in trip mode and if the Run command is present.

2 (PddP) : The controller will start automatically at power-up if it was running when the mains power supply was cut out and if the Run command is present. It will not start if it was stopped when the mains power supply was cut out.

CAUTION :

This parameter is not operational if 06.04 = 2 - 3 or 4 because for these 3 modes, the Run inputs must remain enabled to keep the controller running.

06.03 : Mains loss mode

Range : 0 to 2

Factory setting : 0

This parameter can be set at the 3 following values :

0	diS	Not sensitive to microcuts
1	StoP	Deceleration until stopping
2	ridE.th	Deceleration until the mains is restored

0 (diS) : When a microcut occurs, the controller keeps on running as long as the DC bus voltage is sufficient

1 (StoP) : The controller detects the microcut and starts to decelerate in order to recover motor energy and maintain DC bus voltage. When normal conditions are restored, deceleration is maintained until the motor stops

2 (ridE.th) : Ride through. Like before but when normal conditions are restored, the motor accelerates again to set speed.

06.04 : Assignment and processing of logic commands

Range : 0 to 4

Factory setting : 4

5 logic command processing modes are available. The configuration of the terminal block for each value of 06.04 is given in paragraph 6.5.2.

0 : See terminal block configuration § 4.5.2.2 : 06.04 = 0
The Forward/Reverse and Run keys of the keypad have priority over terminals 27 and 28, provided they are enabled.

1 : See terminal block configuration § 4.5.2.2 : 06.04 = 1
The Forward/Reverse and Run keys of the keypad operate provided they are enabled, but terminals 27 and 28 have priority.

2 : See terminal block configuration § 4.5.2.2 : 06.04 = 2
In this mode, the terminals must be permanently made active to remain enabled. The Forward/Reverse and Run keys of the keypad are thus not available.

3 : See terminal block configuration § 4.5.2.2 : 06.04 = 3
In this mode, the terminals must be permanently made active to remain enabled. The Forward/Reverse and Run keys of the keypad are thus not available.

4 : See terminal block configuration § 4.5.2.2 :

06.04 = 4

In this mode, terminals must be permanently made active to remain enabled. Forward / Reverse and Run keys of the controller are thus not available.

CAUTION : If 06.04 = 0, 1 or 2, parameter 08.23 should be set at 06.34.

Speed controller for asynchronous motors UMV 2301 AS

06.05 : Minimum jog time

Range : 0,0 to 25,0s
Factory setting : 1s

This parameter can be used to set a minimum jog time corresponding to a pulse on a "jog" input.
This parameter is not operational if 06.04 = 2 - 3 or 4.

06.06 : DC injection braking level

Range : 0,0 to 1 max controller.
Factory setting : 100,0 %

This parameter sets the current level used for DC injection braking.

The current limit is given hereafter :

$$150,0 \times \frac{\text{controller rated current}}{\text{motor rated current}}$$

06.07 : DC injection braking time

Range : 0,0 to 25,0s
Factory setting : 5,0s

This parameter sets the low frequency current injection braking time when 06.01 = td-dcl.

06.08 : Hold zero speed

Range : 0 or 1
Factory setting : 0

When this parameter is set to 1, the controller will hold torque at standstill following a stop command instead of disabling the output bridge. Controller status will be "StoP" when it has stopped rather than "rdY".

06.09 : Enable catch spinning motor

Range : 0 or 1
Factory setting : 1

0 : no spin restart after fugitive cut-out.

1 : spin restart. After a fugitive cut-out of the mains, the controller measures the frequency of the remanent motor voltage in order to determine its rotating speed. Thus the controller automatically readjusts speed reference to actual motor speed.

 • If the load is stationary when run command is given or when mains supply is restored, this operation can cause an unwanted rotation of the machine before the motor accelerates.

• Make sure this function does not affect safety of personnel and machinery.

06.10 : Spinning motor ramp rate

Range : 0 to 25,0 s / 100 Hz
Factory setting : 5,0 s / 100 Hz

This parameter sets the frequency ramp rate during the spin restart test.

A low value should be set for applications with small inertial load in order to have a precise speed detection.
Set a higher value for applications with high inertial load in order to prevent overvoltage trip.

06.11 : Enable keypad Run key

Range : 0 or 1
Factory setting : 0

This parameter enables the "Run" key of the keypad. Default setting of this parameter will automatically be 1 when keypad reference is selected and 0 otherwise. Automatic enabling of the "Run" key can be forbidden with parameter 06.14.

0 : Run key disabled.

1 : Run key enabled.

06.12 : Enable keypad Stop key

Range : 0 or 1
Factory setting : 0

This parameter enables the "Stop" key of the keypad. Default setting of this parameter will automatically be 1 when keypad reference is selected and 0 otherwise. Automatic enabling of the "Stop" key can be forbidden with parameter 06.14.

0 : Stop key disabled.

1 : Stop key enabled.

06.13 : Enable keypad Forward / Reverse key

Range : 0 or 1
Factory setting : 0

This parameter enables the "Forward / Reverse" key of the keypad. Default setting of this parameter will automatically be 1 when keypad reference is selected and 0 otherwise. Automatic enabling of the "Forward / Reverse" key can be forbidden with parameter 06.14.

0 : Forward / Reverse key disabled.

1 : Forward / Reverse key enabled.

06.14 : Disable automatic selection of keys

Range : 0 or 1
Factory setting : 0

0 : Automatic enabling of keys is allowed.

1 : The keys are not automatically enabled when keypad reference is selected. The keys can be individually enabled with parameters 06.11 to 06.13.

06.15 : Drive enable

Range : 0 or 1
Factory setting : 1

0 : Controller enabled.

1 : Controller disabled.

06.16 : kWh cost

Range : 0,0 to 300,00 currency/kWh
Factory setting : 0 currency/kWh

When this parameter is set correctly for local currency, parameter 06.26 will allow immediate reading of running costs.

Speed controller for asynchronous motors UMV 2301 AS

06.17 : Reset power meter

Range : 0 or 1

Factory setting : 0

When this parameter is set to 1, parameters 06.24 and 06.25 are reset to 0.

06.18 : Running time before alarm 1

Range : 0 to 30000h

Factory setting : 0h

This parameter sets running time before alarm release.

06.19 : Alarm 1 and meter reset

Range : 0 or 1

Factory setting : 0

This parameter is set to 1 when running time before alarm 1 has run out.

If this parameter is reset to 0, the meter is reset to its initial value (06.18).

06.20 : Running time before alarm 2

Range : 0 to 30000h

Factory setting : 0h

This parameter sets running time before alarm release.

06.21 : Alarm 2 and meter reset

Range : 0 or 1

Factory setting : 0

This parameter is set to 1 when running time before alarm 2 has run out.

If this parameter is reset to 0, the meter is reset to its initial value (06.20).

06.22 : Time counter (years and days)

Range : 0,000 to 30,365 years, days

This parameter records running years and days since first start-up of the controller.

06.23 : Time counter (hours and minutes)

Range : 0,00 to 23,59 h, min

This parameter records running years and days since first start-up of the controller.

After 23h59 min, 06.23 is reset to 0 and 06.22 is incremented with 1 day.

06.24 : Power meter (MWh)

Range : 0 to 30000 MWh

This parameter records the power consumption of the controller expressed in MWh.

This meter can be reset to 0 by setting parameter 06.17 to 1.

06.25 : Power meter (kWh)

Range : 0,0 to 999,9 kWh

This parameter records the power consumption of the controller expressed in kWh.

This meter can be reset to 0 by setting parameter 06.17 to 1.

06.26 : Running cost

Range : 0,00 to 300,00 currency / hour

Immediate reading of running cost of the drive per hour.

This requires parameter 06.16 to be set up correctly.

06.27 : Time before alarm 1

Range : 0 to 30000 h

This parameter informs about running time remaining before the controller releases alarm 1.

06.28 : Time before alarm 2

Range : 0 to 30000 h

This parameter informs about running time remaining before the controller releases alarm 2.

06.29 : Hardware enable

Range : 0 or 1

If parameter 08.09 is set to 1, terminal 30 becomes drive enable input. In that case parameter 06.29 is set to 0 when the controller is enabled and to 1 when it is disabled.

If parameter 08.09 = 0, then parameter 06.29 remains permanently at 1.

06.30 to 06.33 : Sequencing bits

06.34 : Run permit or / Stop

Range : 0 or 1

Factory setting : 0

The processing unit of the controller logic commands (06.04) uses these bits as inputs rather than directly referring to the terminals. This allows the customer to define the use of each drive terminal according to the requirements of each application. Although these parameters are of read / write type, they are volatile and are not stored at power down. They will be reset to 0 each time the controller is powered up.

06.30 : Sequencing bit 0 logic commands

06.31 : Sequencing bit 1 logic commands

06.32 : Sequencing bit 2 logic commands

06.33 : Sequencing bit 3 logic commands

06.34 : Run permit or/Stop

Speed controller for asynchronous motors UMV 2301 AS

06.35 & **06.36** : Limit switch inputs

Range : 0 or 1

These parameters cause the controller to stop at each end of a traverse of some kind when they are set to 1. They can be used as full stroke limits.

06.35 causes the controller to stop when operating in forward direction.

06.36 causes the controller to stop when operating in reverse direction.

06.37 : Spinning motor start voltage

Range : 0 to 100,0 % of rated voltage

Factory setting : 25,0 %

This parameter sets the voltage applied during the spin restart procedure. A value set too high will induce a current limitation and might cause tripping, while too low a value will give detection problems at low speeds.

06.38 : Spinning motor voltage ramp

Range : 0 to 2,50 s

Factory setting : 0,25 s

When the spin restart procedure is completed, the controller will progressively increase the voltage from the value set in 06.37 to the normal running voltage corresponding to frequency reference. This parameter allows ramp adjustment. A time set too short will cause unwanted current transient peaks, while too long a time should be avoided for applications where speed is rapidly decreasing.

Speed controller for asynchronous motors UMV 2301 AS

4.5.3 - MENU 7 : ASSIGNMENT OF ANALOGUE INPUTS AND OUTPUTS

4.5.3.1 - List over parameters in Menu 7

 Parameters also available in menu 0

Parameter	Description	Type	Adjustment range	Unit	Factory setting	User setting
07.01	Analogue input 1	RO	±100 %	%	-	-
07.02	Analogue input 2	RO	±100 %	%	-	-
07.03	Analogue input 3	RO	±100 %	%	-	-
07.04	Heat sink temperature	RO	0 à 100	°C	-	-
07.05	Ambient temperature	RO	0 à 70	°C	-	-
07.06	Analogue input 1 mode	R-W	0 à 8	Code	0	
07.07	Offset trim analogue input 1	R-W	± 10,000	%	0	
07.08	Scaling analogue input 1	R-W	0,000 to 4,000	Factor	1,000	
07.09	Invert bits analogue input 1	R-W	0 or 1	-	0	
07.10	Destination analogue input 1	R-W	0,00 to 20,50	Menu-parameter	1.36	
07.11	Analogue input 2 mode	R-W	0 to 8	Code	0	
07.12	Scaling analogue input 2	R-W	0,000 to 4,000	Factor	1,000	
07.13	Invert bits analogue input 2	R-W	0 or 1	-	0	
07.14	Destination analogue input 2	R-W	0,00 to 20,50	Menu-parameter	1.37	
07.15	Analogue input 3 mode	R-W	0 to 10	Code	10	
07.16	Scaling analogue input 3	R-W	0,000 to 4,000	Factor	1,000	
07.17	Invert bits analogue input 3	R-W	0 or 1	-	0	
07.18	Destination analogue input 3	R-W	0,00 to 20,50	Menu-parameter	0.00	
07.19	Sources analogue output 1	R-W	0,00 to 20,50	Menu-parameter	0.12	
07.20	Scaling analogue output 1	R-W	0,000 to 4,000	Factor	1,000	
07.21	Analogue output 1 mode	R-W	0 to 2	Code	0	
07.22	Sources analogue output 2	R-W	0,00 to 20,50	Menu-parameter	0.13	
07.23	Scaling analogue output 2	R-W	0,000 to 4,000	Factor	1,000	
07.24	Analogue output 2 mode	R-W	0 to 2	Code	0	
07.25	Calibrate analogue input 1 full scale	R-W	0 or 1	-	0	
07.27	Loss of 4-20mA on analogue input 1	RO	0 or 1	-	-	-
07.28	Loss of 4-20mA on analogue input 2	RO	0 or 1	-	-	-
07.29	Loss of 4-20mA on analogue input 3	RO	0 or 1	-	-	-

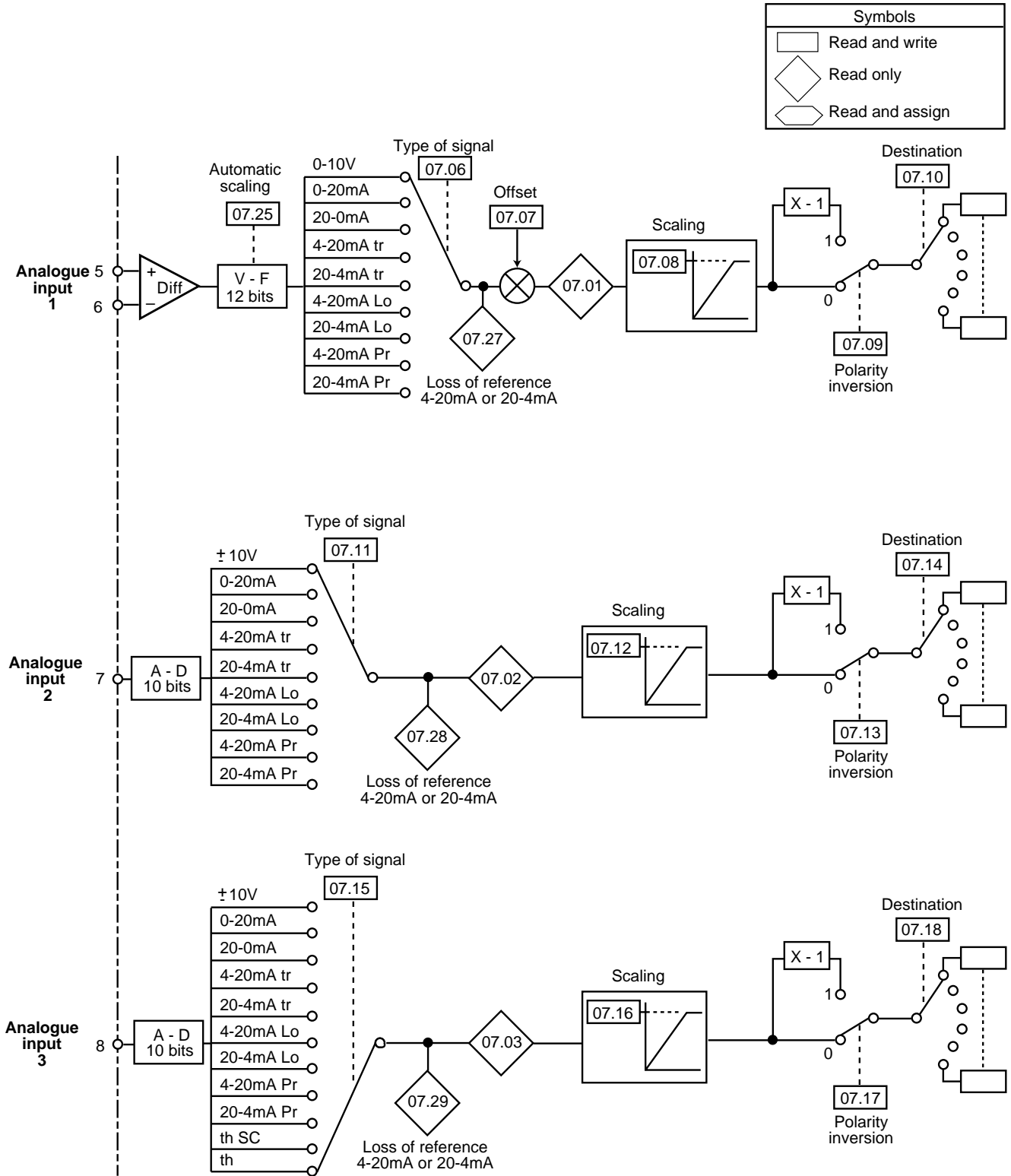

Speed controller for asynchronous motors UMV 2301 AS

4.5.3.2 - Block diagrams Menu 7 Assignment of analogue inputs



Speed controller for asynchronous motors UMV 2301 AS

Assignment of analogue inputs Controller environment

Symbols	
	Read and write
	Read only
	Read and assign

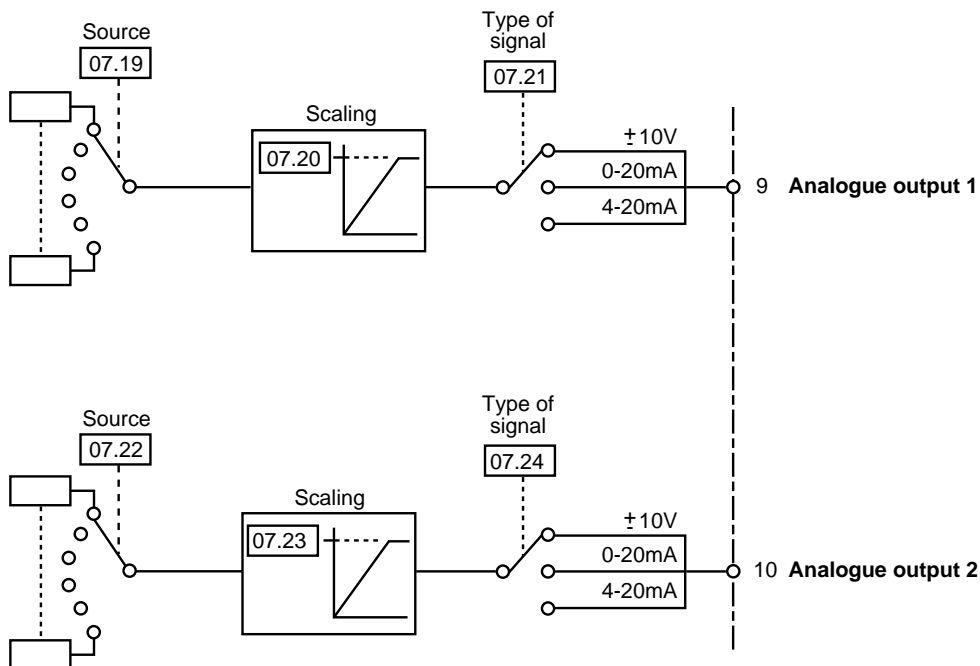

Controller environment

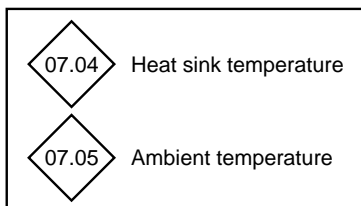

Speed controller for asynchronous motors UMV 2301 AS

4.5.3.3 - Description of parameters in menu 7

07.01 to **07.03** : Analogue inputs

Range : ± 100 % of variation range of parameter assigned to the analogue input.

- Allows to read corresponding analogue input.
- Analogue input 1 features a Voltage-to-Frequency converter with a resolution of 12 bits + sign and a better noise immunity. Inputs 2 and 3 are fitted with an Analogue - Digital converter with a resolution of 10 bits + sign.

Parameter variation ranges are ± 100 % for voltage inputs and 0 - 100 % for current inputs.

07.04 : Heat sink temperature

Range : 0 to 100 °C

Reads the temperature measured in the heat sink. If the level reaches 98 °C the controller trips and does not allow restarting as long as the temperature is over 94°C.

07.05 : Ambient temperature

Range : 0 to 70 °C

Reads the ambient temperature measured in the vicinity of the control board. If the measured value reaches 70°C the controller trips and does not allow restarting as long as the temperature is over 65 °C.

07.06 , **07.11** : Analogue input modes

07.15

Range : 0 to 8 on analogue inputs 1 et 2
0 to 10 on analogue input 3

Factory setting : 07.06 = 0 : Analogue input 1 configured as voltage input
07.11 = 0 : Analogue input 2 configured as voltage input
07.15 = 10 : Analogue input 3 configured for processing of motor probes

Signal of analogue input 1 (terminals 5 and 6) can be set up for different types of control signal.

0 (Volt) : Voltage input $\pm 10V$.

1 (0-20) : Current input 0 - 20mA.

2 (20-0) : Current input 20 - 0mA.

3 (4-20.tr) : Current input 4 - 20mA with trip release on signal loss.

4 (20-4.tr) : Current input 20 - 4mA with trip release on signal loss.

5 (4-20.Lo) : Current input 4 - 20mA with changeover to minimum reference on signal loss.

6 (20-4.Lo) : Current input 20 - 4mA with changeover to minimum reference on signal loss.

7 (4-20.Pr) : Current input 4 - 20mA with upholding of reference before tripping on signal loss.

8 (20-4.Pr) : Current input 20 - 4mA with upholding of reference before tripping on signal loss.

9 (th.SC) : Thermistor with tripping on short-circuit detection.

10 (th) : Thermistor without short-circuit detection.

Note : For 4-20mA or 20-4mA modes the signal loss threshold is 3mA.

07.07 : Offset trim, analogue input 1

Range : $\pm 10,000$ %

Factory setting : 0 %

This parameter is used to add or subtract a fixed value on analogue input 1.

07.08 , **07.12** : Analogue input scaling

07.16

Range : 0,000 to 4,000

Factory setting : 1,000

These parameters can be used, if necessary, to scale the analogue inputs. This however is rarely needed as the maximum input level (100 %) automatically corresponds to the maximum value of the destination parameter.

07.09 , **07.13** : Input inversion bits

07.17

Range : 0 or 1

Factory setting : 0

This parameter is used to invert the polarity of the input signal.

0 : Input signal not inverted.

1 : Input signal inverted.

07.10 , **07.14** : Analogue input destination

07.18

Range : 0,00 to 20,50

Factory setting : 07.10 = 1.36 : Analogue input 1 routed to Frequency reference 1
07.14 = 1.37 : Analogue input 2 routed to Frequency reference 2
07.18 = 0.00 : Analogue input 3 routed to processing of motor probes

These addresses must include the number of the parameter chosen for assignment to the analogue inputs.

Only analogue parameters can be assigned.

If a non valid parameter is programmed, the input is not routed anywhere.

Speed controller for asynchronous motors UMV 2301 AS

07.19 , 07.22 : Sources, analogue outputs

Range : 0,00 to 20,50

Factory setting : 07.19 = 5.01 : Output frequency

07.22 = 4.02 : Active current

These addresses must include the number of the parameter chosen for assignment to the analogue outputs.

Only analogue parameters can be assigned.

If an inadequate parameter is programmed, the corresponding analogue output will be set to 0.

07.20 , 07.23 : Analogue output scaling

Range : 0,000 to 4,000

Factory setting : 1,000

These parameters can be used, if necessary, to set the analogue outputs to scale. This however is rarely needed as the maximum level of the analogue output corresponds automatically to the maximum value of the parameter assigned to the analogue output.

07.21 , 07.24 : Analogue output modes

Range : 0 to 2

Factory setting : 0

Each of both analogue outputs can be configured in 3 different ways.

0	VOLt	Output range $\pm 10V$
1	0-20	Output range 0 to 20 mA
2	4-20	Output range 4 to 20 mA

For current outputs, the negative values of a parameter will be treated as zero.

Analogue outputs are restored every 8ms.

07.25 : Automatic scaling of analogue input 1

Range : 0 or 1

Factory setting : 0

When this parameter is set to 1 automatic scaling of analogue input 1 is performed.

The value of the analogue input when it is calibrated will be considered as its maximum value.

Input voltage or current must be higher than 25 % of maximum voltage or current (2,5V or 5mA) when it is calibrated.

Memory storage of the maximum value is automatically performed when the controller is powered down.

Automatic scaling can be cancelled by restarting the procedure with an input signal lower than 15 % of the maximum value (1,5V or 4,6mA).

Scaling must be done with the drive stopped.

Parameter 07.25 is automatically reset to 0 when scaling has been completed.

07.27 to 07.29 : Loss of signal 4-20mA

Range : 0 or 1

These parameters are set to 1 when the signal on analogue input 1 falls below 3mA in 4-20mA current mode.

**Speed controller for
asynchronous motors
UMV 2301 AS**

Notes

Speed controller for asynchronous motors UMV 2301 AS

4.5.4 - MENU 8 : ASSIGNMENT OF LOGIC INPUTS AND OUTPUTS

4.5.4.1 - List over parameters in Menu 8

Parameter	Description	Type	Adjustment range	Unit	Factory setting	User setting
08.01	Terminal 24 input or output status indicator	RO	0 or 1	-	-	-
08.02	Terminal 25 input or output status indicator	RO	0 or 1	-	-	-
08.03	Terminal 26 input or output status indicator	RO	0 or 1	-	-	-
08.04	Terminal 27 input status indicator	RO	0 or 1	-	-	-
08.05	Terminal 28 input status indicator	RO		-	-	-
08.06	Terminal 29 input status indicator	RO		-	-	-
08.07	Terminal 30 Enable/Trip input indicator	RO		-	-	-
08.08	Relay output indicator	RO		-	-	-
08.09	Select enable input on terminal 30	R-W	0 or 1	-	0	
08.10	Terminal 24 input destination or output source	R-W	0.00 to 20.50	Menu-parameter	10.06	
08.11	Terminal 24 logic input / output invert	R-W	0 or 1	-	0	
08.12	Configuration of terminal 24 as input or output	R-W	0 or 1	-	1	
08.13	Terminal 25 input destination or output source	R-W	0.00 to 20.50	Menu-parameter	10.33	
08.14	Terminal 25 logic input / output invert	R-W	0 or 1	-	0	
08.15	Configuration of terminal 25 as input or output	R-W	0 or 1	-	0	
08.16	Terminal 26 input destination or output source	R-W	0.00 to 20.50	Menu-parameter	01.45	
08.17	Terminal 26 logic input / output invert	R-W	0 or 1	-	0	
08.18	Configuration of terminal 26 as input or output	R-W	0 or 1	-	0	
08.19	Terminal 27 input destination	R-W	0.00 to 20.50	Menu-parameter	06.30	
08.20	Terminal 27 logic input / output invert	R-W	0 or 1	-	0	
08.21	Terminal 28 input destination	R-W	0.00 to 20.50	Menu-parameter	06.32	
08.22	Terminal 28 logic input / output invert	R-W	0 or 1	-	0	
08.23	Terminal 29 input destination	R-W	0.00 to 20.50	Menu-parameter	01.42	
08.24	Terminal 29 logic input / output invert	R-W	0 or 1	-	0	
08.25	Relay output source	R-W	0.00 to 20.50	Menu-parameter	10.01	
08.26	Relay state invert	R-W	0 or 1	-	0	
08.27	Logic input polarity	R-W	0 or 1	-	0	
08.28	Open collector outputs	R-W	0 or 1	-	0	

Speed controller for asynchronous motors UMV 2301 AS

4.5.4.2 - Block diagrams Menu 8 Assignment of logic inputs / outputs

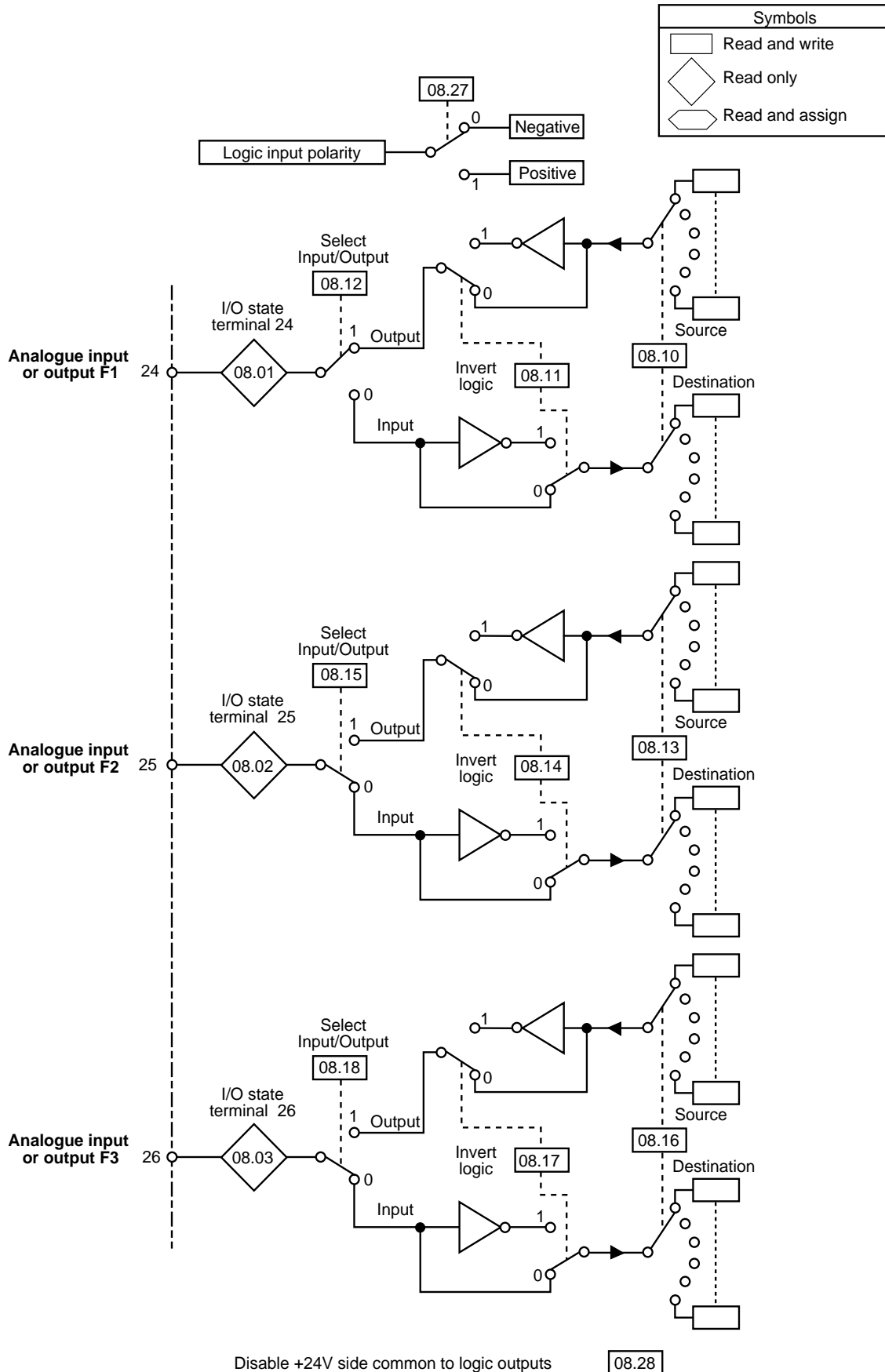

Speed controller for asynchronous motors UMV 2301 AS

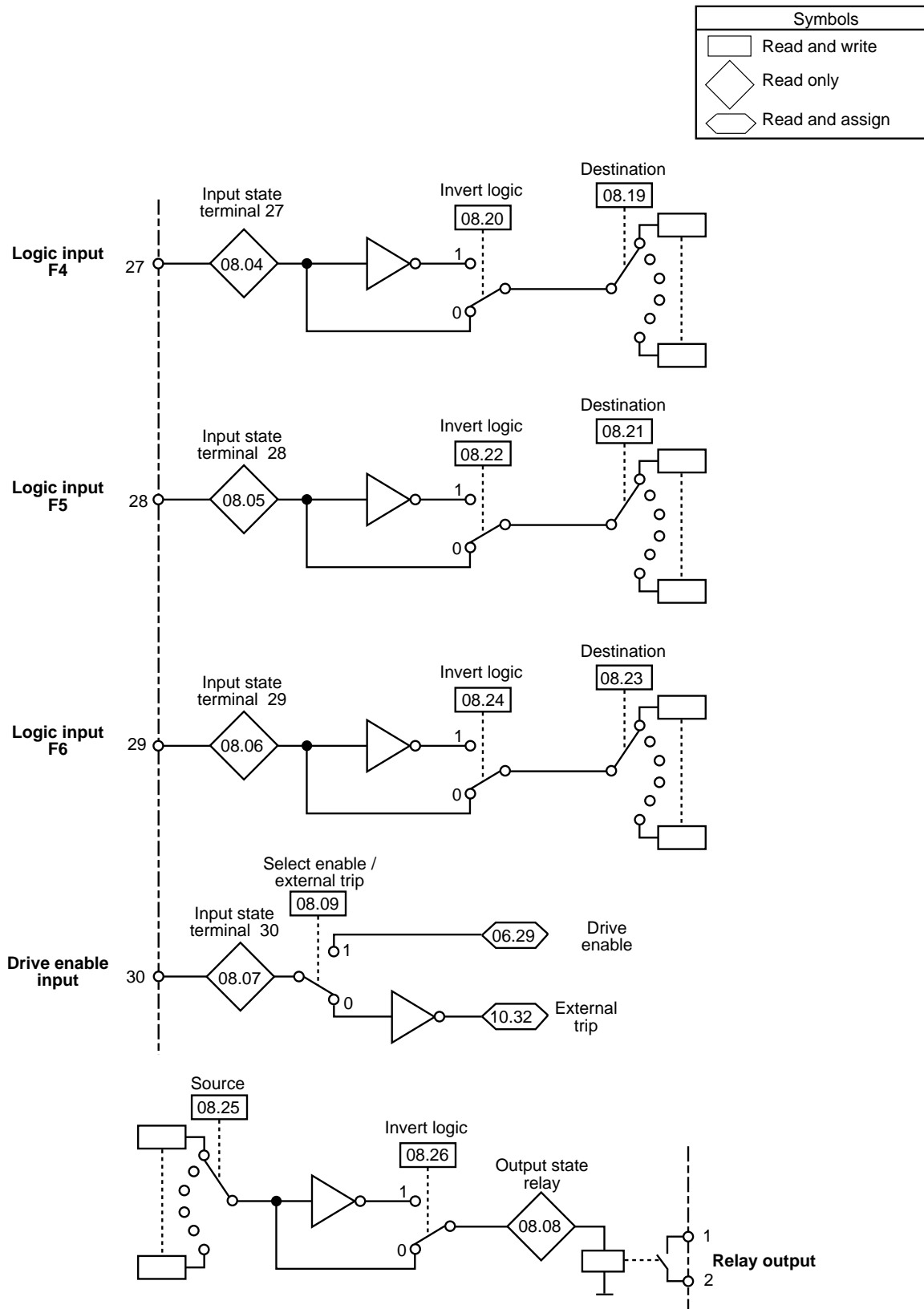

Assignment of logic inputs and relay output



Speed controller for asynchronous motors UMV 2301 AS

4.5.4.3 - Description of parameters in menu 8

Terminals 24 to 26 can be configured as inputs or outputs, while terminals 27 to 29 are inputs only. All six are fully programmable. Furthermore, terminal 30 is a dedicated input which can be used either as an enable input or as external trip input. If both features are required then terminal 30 should be used as drive enable input and one of the other inputs should be programmed to control the external trip bit (an inversion of the input logic will be necessary to avoid tripping when input terminal is active). The logic inputs are sampled and the logic outputs are updated every 8 ms.

 to  : **Input / Output indicators (terminals 24 to 26)**

Range : 0 or 1

These parameters indicate the input state of the terminals if these are set up as inputs, or the output state if they are set up as outputs.



For the inputs, 0 = disabled and 1 = enabled.

For the outputs, 0 = closed and 1 = open.

08.01 = Status of terminal 24

08.02 = Status of terminal 25

08.03 = Status of terminal 26

 to  : **Input indicators (terminals 27 to 29)**

Range : 0 or 1

These parameters indicate the state of these inputs :

0 = disabled and 1 = enabled.

08.04 = Status of terminal 27

08.05 = Status of terminal 28

08.06 = Status of terminal 29

 : **Enable/Trip input indicator (terminal 30)**

Range : 0 or 1

This parameter indicates the state of the Enable/Trip input (terminal 3) :

0 : disabled.

1 : enabled.

 : **Relay output indicator**

Range : 0 or 1

This parameter indicates the state of the drive relay (terminals 1 and 2) :

0 : Relay inactive.

1 : Relay active.

 : **Select enable input (terminal 30)**



Range : 0 or 1

Factory setting : 0

Terminal 30 of the controller can be configured either as drive enable input or as external trip input.

0 : External trip.

1 : Enabled

 ,  : **Input destination or output source, terminals 24 to 26 and relay output**

Range : 0.00 to 20.50

Factory setting : 08.10 (Terminal 24) : 10.06

(At speed output)

: 08.13 (Terminal 25) : 10.33

(Trip clearance input)

: 08.16 (Terminal 26) : 01.45



(Select preset frequency 1/2)

: 08.25 (Relay output) : 10.01

(Controller not tripping)

These parameters are used to select the destination of the input if the terminal is set up as an input or the source of the output if the terminal is set up as an output. Only unprotected " bit " type parameters can be routed to inputs or outputs.

If a non valid parameter is addressed to an input or an output, no assignment will be taken into account.

  : **Input destination, terminals 27 to 29**



Range : 0.00 to 20.50

Factory setting : 08.19 (Terminal 27) : 06.30

(Forward / Stop input)

: 08.21 (Terminal 28) : 06.32

(Reverse / Stop input)

: 08.23 (Terminal 29) : 01.42



(Select analogue or preset

frequency reference)

These parameters are used to select the destination of the logic inputs.

Only unprotected " bit " type parameters can be assigned to inputs.

If a non valid parameter is programmed, the input will not be routed anywhere.

 ,  : **Invert parameters, logic inputs or outputs**

 , 

 , 



Range : 0 or 1

Factory setting : 0

08.11 - Terminal 24 } Allow to invert destination
08.14 - Terminal 25 } parameter of input or
08.17 - Terminal 26 } source parameter of output

08.20 - Terminal 27 } Allow to invert destination
08.22 - Terminal 28 } parameter of logic input
08.24 - Terminal 29 }

08.26 - Relay invert : This parameter allows to invert the relay output

0 : Input or output not inverted.

1 : Input or output inverted.

Speed controller for asynchronous motors UMV 2301 AS

08.12 **08.15** : Activate output parameters

08.18 (terminals 24 to 26)

Range : 0 or 1

Factory setting : 08.12 (Terminal 24) : 1 (Output)
 : 08.15 (Terminal 25) : 0 (Input)
 : 08.18 (Terminal 26) : 0 (Input)

These parameters allow to set up terminals 24 to 26 as input or output.

0 : Configuration of terminal as Input.

1 : Configuration of terminal as Output.

08.27 : Logic input polarity

Range : 0 or 1

Factory setting : 0

This parameter allows to choose a positive or negative logic polarity on digital inputs.

0 : Negative logic, input is enabled when the terminal is driven at a low level (< 5V).

1 : Positive logic, input is enabled when the terminal is driven at a high level (> 15V).

08.28 : Open collector outputs

Range : 0 or 1

Factory setting : 0

Allows to disable the +24V high side of the logic circuits. Thus several controllers can be connected together in a wired "OR" configuration.

0 : +24V enabled.

1 : +24V disabled.

**Speed controller for
asynchronous motors
UMV 2301 AS**

Notes

Speed controller for asynchronous motors UMV 2301 AS



4.5.5 - MENU 9 : LOGIC FUNCTIONS AND FASTER / SLOWER COMMAND

4.5.5.1 - List over parameters in Menu 9

Parameter	Description	Type	Adjustment range	Unit	Factory setting	User setting
09.01	Output indicator of logic function 1 & 2	RO	0 or 1	-	-	-
09.02	Output indicator of logic function 3 & 4	RO	0 or 1	-	-	-
09.03	Motorized pot output	RO	± 100,0	%	-	-
09.04	Source of input 1 of function 1 & 2	R-W	0.00 to 20.50	Menu-parameter	0	
09.05	Invert input 1 of function 1 & 2	R-W	0 or 1	-	0	
09.06	Source of input 2 of function 1 & 2	R-W	0.00 to 20.50	Menu-parameter	0	
09.07	Invert input 2 of function 1 & 2	R-W	0 or 1	-	0	
09.08	Invert output of function 1 & 2	R-W	0 or 1	-	0	
09.09	Delay function 1 & 2	R-W	0,0 to 25,0	s		
09.10	Destination of output of function 1 & 2	R-W	0.00 to 20.50	Menu-parameter	0	
09.11	Not used					-
09.12	Not used					-
09.13	Not used					-
09.14	Source of input 3 of function 3 & 4	R-W	0.00 to 20.50	Menu-parameter	0	
09.15	Invert input 3 of function 3 & 4	R-W	0 or 1	-	0	
09.16	Source of input 4 of function 3 & 4	R-W	0.00 to 20.50	Menu-parameter	0	
09.17	Invert input 4 of function 3 & 4	R-W	0 or 1	-	0	
09.18	Invert output of function 3 & 4	R-W	0 or 1	-	0	
09.19	Delay function 3 & 4	R-W	0,0 to 25,0	s		
09.20	Destination of output of function 3 & 4	R-W	0.00 to 20.50	Menu-parameter	0	
09.21	Select automatic reset of faster / slower command reference	R-W	0 or 1	-	0	
09.22	Select polarity of faster / slower reference	R-W	0 or 1	-	0	
09.23	Ramp rate of faster / slower command reference	R-W	0 to 250	s	20	
09.24	Scaling of faster / slower command reference	R-W	0,000 to 4,000	Factor	1,000	
09.25	Destination of faster / slower command reference	R-W	0.00 to 20.50	Menu-parameter	0	
09.26	Input faster	R-W	-	-	-	-
09.27	Input slower	R-A	-	-	-	-
09.28	Reset of faster / slower command reference	R-A	0 or 1	-	-	
09.29	Binary input 1 of binary / decimal converter	R-A	-	-	-	-
09.30	Binary input 2 of binary / decimal converter	R-A	-	-	-	-
09.31	Binary input 3 of binary / decimal converter	R-A	-	-	-	-
09.32	Read decimal output	RO	0 to 7	-	-	-
09.33	Destination of decimal output	R-W	0.00 to 20.50	Menu-parameter	0	

Speed controller for asynchronous motors UMV 2301 AS

4.5.5.2 - Block diagrams Menu 9 Logic functions

Symbols	
	Read and write
	Read only
	Read and assign

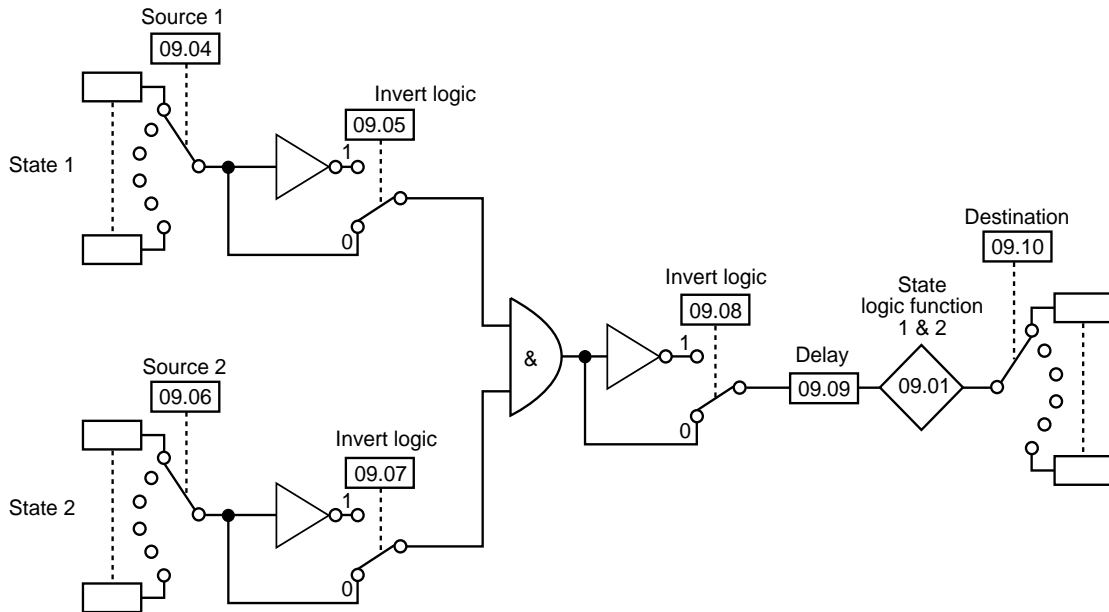

Logic function 1 & 2

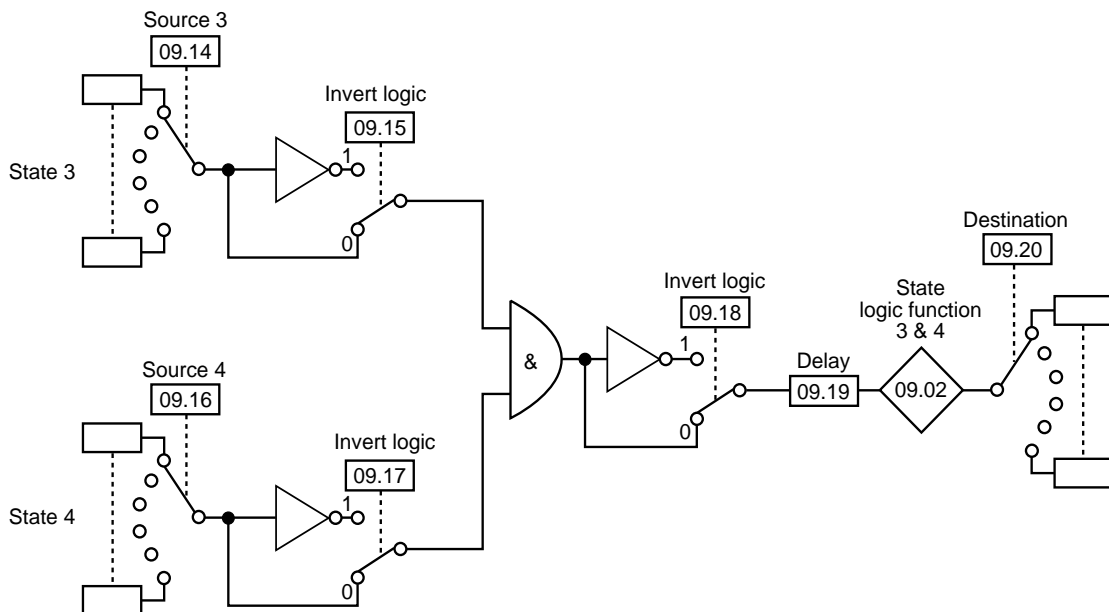

Logic function 3 & 4



Speed controller for asynchronous motors UMV 2301 AS

Symbols	
	Read and write
	Read only
	Read and assign

Faster / Slower function

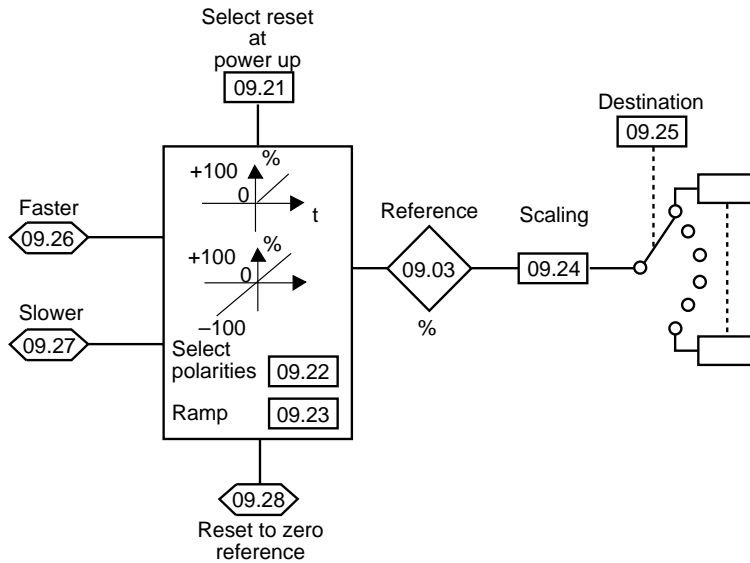

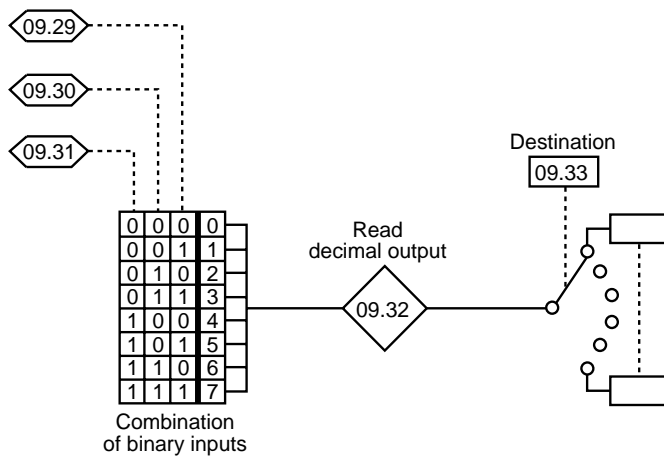

Binary / Decimal converter



Speed controller for asynchronous motors UMV 2301 AS

4.5.5.3 - Description of parameters in menu 9

 **09.01** ,  **09.02** : **Logic function output indicators**

Range : 0 or 1

These parameters indicate the output state of the two programmable logic functions. This output can be routed to a terminal by setting the appropriate digital output source in Menu 8 to output one of these parameters.

09.01 : Logic function 1 output



09.02 : Logic function 2 output

 **09.03** : **Read reference coming from Faster / Slower command**

Range : $\pm 100,0$

Unit : %

Level of the reference given by the motorized potentiometer prior to scaling.

 **09.04** ,  **09.06** : **"AND" functions inputs sources**

 **09.14** ,  **09.16**

Range : 0.00 to 20.50

Factory setting : 09.04 (Source 1 function 1 & 2) : 0

: 09.06 (Source 2 function 1 & 2) : 0

: 09.14 (Source 3 function 3 & 4) : 0

: 09.16 (Source 4 function 3 & 4) : 0

These parameters are used to select the sources of the inputs of the "AND" logic functions.

Only " bit " type parameters can be processed on these input.

If 2 inadequate parameters are addressed on both inputs of an "AND" function, the output of the "AND" function will remain at 0.

If only 1 inadequate parameter is addressed on 1 of both inputs of an "AND" function, this input will be set at 1.

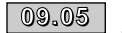
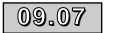
 **09.05** ,  **09.07** : **Logic inversion of "AND" functions inputs**

 **09.15** ,  **09.17**

Range : 0 or 1

Factory setting : 09.05 (Inversion of input 1 of function 1 & 2) : 0

: 09.07 (Inversion of input 2 of function 1 & 2) : 0

: 09.15 (Inversion of input 3 of function 3 & 4) : 0

: 09.17 (Inversion of input 4 of function 3 & 4) : 0

These parameters are used to make a logic inversion on the inputs of the "AND" functions.

0 : Input not inverted.

1 : Input inverted

 **09.08** ,  **09.18** : **Logic inversion of "AND" functions outputs**

Range : 0 or 1

Factory setting : 09.08 (Inversion of output of function 1 & 2) : 0

: 09.18 (Inversion of output of function 3 & 4) : 0

These parameters are used to make a logic inversion on the outputs of the "AND" functions.

0 : Output not inverted.

1 : Output inverted

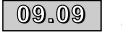
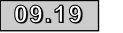
 **09.09** ,  **09.19** : **Time delay of "AND" functions outputs**



Range : 0,0 to 25,0s

Factory setting : 09.09 (Time delay of the output of function 1 & 2) : 0

: 09.19 (Time delay of the output of function 3 & 4) : 0

These parameters are used to introduce a time delay on the outputs of the "AND" functions.

This time delay is only active when the output switches from 0 to 1 (Operational time delay).

 **09.10** ,  **09.20** : **Destination of "AND" functions outputs**

Range : 0.00 to 20.50

Factory setting : 09.10 (Destination of the output of function 1 & 2) : 0

: 09.20 (Destination of the output of function 3 & 4) : 0

These parameters define which internal parameters will be assigned by the outputs of the "AND" functions.

Only unprotected " bit " type parameters can be addressed.

If an inadequate parameter is programmed, the destination will not be taken into account.

 **09.21** : **Select automatic reference reset for Faster / Slower command**

Range : 0 or 1

Factory setting : 0

0 : Reference of Faster / Slower command will remain at the same level on power-up as it was on power-down.

1 : Reference of Faster / Slower command will be reset at zero each time the controller is powered up.

 **09.22** : **Select polarity of Faster / Slower reference**

Range : 0 or 1

Factory setting : 0

0 : Reference of Faster / Slower command is limited to positive values (0 to 100,0 %).

1 : Reference of Faster / Slower command could vary between -100 % and +100 %.

Speed controller for asynchronous motors UMV 2301 AS

09.23 : Ramp rate of reference of Faster / Slower command

Range : 0 to 250s

Factory setting : 20

This parameter sets the time which is necessary for the reference of the Faster / Slower command to vary from 0 to 100,0 %.

Twice as much time will be needed for the reference to vary from -100,0 % to +100,0 %.

This parameter sets the sensitivity of the command.

09.24 : Scaling of reference of Faster / Slower command

Range : 0,000 to 4,000

Factory setting : 1,000

The maximum value of the reference of the Faster / Slower command automatically takes the maximum value of the analogue reference it is assigned to.

This parameter thus allows to adapt the maximum value of the reference of the Faster / Slower command to the maximum value required for the application.

Example :

- The reference of the Faster / Slower command is addressed to a preset speed.

- The maximum value of a preset speed is 1000 Hz.

- It is requested that the maximum value of the Faster / Slower reference corresponds to 50 Hz.

==> $09.24 = \frac{50}{1000} = 0,05$.

09.25 : Destination of reference of Faster / Slower command

Range : 0.00 to 20.50

Factory setting : 0

This parameter is used to define which analogue parameter will be controlled by the reference of the Faster / Slower command.

• Example 1 : The reference of the Faster/Slower command is used as speed reference. It is possible to send the reference of the Faster/Slower command to a preset speed.

==> $09.25 = 01.21$.

• Example 2 : The reference of the Faster/Slower command is used to adjust speed of a machine. It is possible to send the reference of the Faster / Slower command to the speed reference offset.

==> $09.25 = 01.04$.

09.26 & 09.27 : Inputs Faster, Slower

Two logic inputs must be assigned to these parameters of the command of Faster / Slower function.

09.26 : Input Faster.

09.27 : Input Slower.

09.28 : Manual reset of reference of Faster / Slower command

Range : 0 or 1

Factory setting : 0

When this parameter is set at 1, the reference of the Faster / Slower command is reset at zero.

09.29 , 09.30 , 09.31 : Binary inputs of the binary / decimal converter

• Assign 1 logic input to obtain a decimal conversion 0 or 1.

• Assign 2 logic inputs to obtain a decimal conversion 0 to 3.

• Assign 2 logic inputs to obtain a decimal conversion 0 to 7.

09.29 : Input binary sum 1.

09.30 : Input binary sum 2.

09.31 : Input binary sum 4.

Allows remote modification of a parameter which selection includes more than 2 possible choices thanks to a combination of logic inputs.

09.32 : Read decimal output

Range : 0 to 7

Allows to read the value of the binary converter output.

09.33 : Destination of decimal output

Range : 0.00 to 20.50

Factory setting : 0

This parameter is used to define which parameter will be controlled by the decimal output.

Example : 04.11 - Torque control features 5 operating modes (0 to 4).

**Speed controller for
asynchronous motors
UMV 2301 AS**

Notes

Speed controller for asynchronous motors UMV 2301 AS

4.5.6 - MENU 10 : STATUS OF CONTROLLER AND DIAGNOSIS

4.5.6.1 - List over parameters in Menu 10

Parameter	Description	Type	Adjustment range	Unit	Factory setting	User setting
10.01	Controller ready	RO	0 or 1	-	-	-
10.02	Enable controller output	RO	0 or 1	-	-	-
10.03	Zero speed	RO	0 or 1	-	-	-
10.04	Minimum speed	RO	0 or 1	-	-	-
10.05	Not used	-	-	-	-	-
10.06	At speed	RO	0 or 1	-	-	-
10.07	Not used	-	-	-	-	-
10.08	Rated load	RO	0 or 1	-	-	-
10.09	Enable current limitation	RO	0 or 1	-	-	-
10.10	Dynamic braking	RO	0 or 1	-	-	-
10.11	Resistor braking	RO	0 or 1	-	-	-
10.12	Alarm overload braking resistor	RO	0 or 1	-	-	-
10.13	Reverse rotation requested	RO	0 or 1	-	-	-
10.14	Reverse rotation	RO	0 or 1	-	-	-
10.15	No mains	RO	0 or 1	-	-	-
10.16	Fault motor overheating	RO	0 or 1	-	-	-
10.17	Alarm It overheating	RO	0 or 1	-	-	-
10.18	Alarm controller overheating	RO	0 or 1	-	-	-
10.19	Alare ambient temperature	RO	0 or 1	-	-	-
10.20	Fault - 1	RO	0 to 99	Code	-	-
10.21	Fault - 2	RO	0 to 99	Code	-	-
10.22	Fault - 3	RO	0 to 99	Code	-	-
10.23	Fault - 4	RO	0 to 99	Code	-	-
10.24	Fault - 5	RO	0 to 99	Code	-	-
10.25	Fault - 6	RO	0 to 99	Code	-	-
10.26	Fault - 7	RO	0 to 99	Code	-	-
10.27	Fault - 8	RO	0 to 99	Code	-	-
10.28	Fault - 9	RO	0 to 99	Code	-	-
10.29	Fault - 10	RO	0 to 99	Code	-	-
10.30	Maximum resistor braking time	R-W	0 to 400s	s	0	
10.31	Maximum resistor braking cycle time	R-W	0,0 to 25,0	mn	0	
10.32	External fault	RO	0 or 1	-	-	-
10.33	Fault clearance	R-W	0 or 1		0	
10.34	Number of automatic fault clearances	R-W	0 to 5	Number	0	
10.35	Time delay of automatic fault clearance	R-W	0 - 25,0s	s	1,0	
10.36	Controller operational status maintained during automatic fault clearances	R-W	0 or 1	-	0	
10.37	Minor faults	R-W	0 or 1	-	0	
10.38	Assignable forced fault	R-W	0 to 100	Code	0	
10.39	Integration of overload braking resistor	RO	0,0 to 100,0	%	-	-
10.40	Decimal value of binary status from 10.01 to 10.15	RO	0 to 32767	-	-	-

Speed controller for asynchronous motors UMV 2301 AS

4.5.6.2 - Block diagrams Menu 10

Status and trips

10.01	Drive ready	10.17	It overload alarm
10.02	Drive running	10.18	Heat sink temperature alarm
10.03	Zero speed	10.19	Ambient temperature alarm
10.04	Minimum speed	10.20	Trip - 1
10.05	Not used	10.21	Trip - 2
10.06	Atspeed	10.22	Trip - 3
10.07	Not used	10.23	Trip - 4
10.08	Rated load	10.24	Trip - 5
10.09	Active current limit	10.25	Trip - 6
10.10	Dynamic braking	10.26	Trip - 7
10.11	Resistor braking	10.27	Trip - 8
10.12	Overload alarm, braking resistor	10.28	Trip - 9
10.13	Reverse rotation commanded	10.29	Trip - 10
10.14	Reverse rotation	10.32	External trip
10.15	Mains loss	10.40	Status word, parameters 10.01 to 10.15
10.16	Motor overheating		

Speed controller for asynchronous motors UMV 2301 AS

Block diagrams Menu 10 (contd)

Resistor braking

10.30 Full power braking time

10.31 Full power braking period

10.39 Braking energy overload accumulator

Fault processing

10.33 Drive reset

10.34 Number of auto reset attempts

10.35 Auto reset delay

10.36 Hold "Drive ready" until last attempt

10.37 Stop drive on minor trips

Speed controller for asynchronous motors UMV 2301 AS

4.5.6.3 - Explication des paramètres du menu 10

10.01 : Controller status operational

Range : 0 or 1

This parameter is set at 1 as long as the controller has not tripped. If parameter 10.36 is set at 1, this bit will remain at 1 during fault phase if an automatic fault clearance is to occur. Once the number of automatic clearances is reached, next fault will set this bit at zero.

10.02 : Controller running

Range : 0 or 1

This parameter is set at 1 when the controller output is enabled.

10.03 : Zero speed

Range : 0 or 1

This parameter is set at 1 when the absolute value of ramp output is ≤ 1 Hz.

10.04 : Operation at speed below or equal to minimum threshold

Range : 0 or 1

In bipolar mode (01.10 = 1) this parameter has the same function as zero speed parameter (10.03).

In unipolar mode this parameter is set at 1 the absolute value of ramp output is \leq minimum frequency + 0,5 Hz. Minimum speed is set with parameter 01.07.

The parameter is operational only when the controller is running.

10.05 : Not used

10.06 : At speed

Range : 0 or 1

This parameter is set at 1 when the absolute value of ramp output is equal to set speed (1.03) ± 1 Hz.

The parameter is operational only when the controller is running.

10.07 : Not used

10.08 : At rated active current

Range : 0 or 1

This parameter is set at 1 when the active current is \geq rated active current.

Rated active current = 00.46 x 00.43.

10.09 : Enable current limitation

Range : 0 or 1

This parameter is set at 1 when the controller is operating with current limitation.

10.10 : Generator mode

Range : 0 or 1

This parameter is set at 1 when energy is transferred from the motor to the DC bus (driving load).

10.11 : Enable dynamic braking

Range : 0 or 1

This parameter is set at 1 when energy is dissipated in the optional braking resistor (provided it is connected).

10.12 : Alarm dynamic braking

Range : 0 or 1

This parameter is set at 1 if dynamic braking is enabled and cumulated braking energy is exceeding 75 %.

10.13 : Indication of requested rotation direction

Range : 0 or 1

This parameter is set at 1 if reference before ramp is negative (reverse).

It is reset at zero if reference before ramp is positive (forward).

10.14 : Indication of rotation direction when running

Range : 0 or 1

This parameter is set at 1 if reference after ramp is negative (reverse).

It is reset at zero if reference before after is positive (forward).

10.15 : Loss of mains

Range : 0 or 1

This parameter is set at 1 when controller input voltage is under 380V -10 %.

10.16 : Motor overheating

Range : 0 or 1

This parameter is set at 1 when motor probe reaches a level over tripping threshold.

10.17 : Alarm overload

Range : 0 or 1

This parameter is set at 1 when motor current is exceeding 105 % of programmed rated motor current and cumulated overload is exceeding 75 % of motor overload capacity. If motor current is not reduced, the controller will trip on l x t.

Speed controller for asynchronous motors UMV 2301 AS

10.18 : Alarm heat sink temperature

Range : 0 or 1

This parameter is set at 1 when heat sink temperature is exceeding 95°C and the controller is still overloaded.

10.19 : Alarm ambient temperature

Range : 0 or 1

This parameter is set at 1 when ambient temperature is exceeding 65°C.

10.20 to 10.29 : Memorization of 10 last faults

Range : 0 to 99

These parameter register the 10 last faults of the controller. Possible faults are :

N°	Mnemonic Display	Fault
1	UU	DC bus undervoltage
2	OU	DC bus overvoltage
3	OI. AC	Overcurrent controller output
4	OI. br	Overcurrent braking resistor
5	PS	Fault internal power supply
6	Et	Forced external fault
7	OV. Spd	Overspeed
19	it. br	Overload braking resistor
20	it. AC	Overload motor I x t
21	Oh 1	Thermal heat sink simulation function of I x t
22	Oh 2	Overheating heat sink detected by temperature probe (over 90°C)
23	OA	Overheating control board
24	th	Trip on motor temperature probe
25	thS	Short-circuit on motor temperature probe CTP (terminal 8) with THS configured input
26	OP.OVLd	Overload on + 24V or logic outputs
27	CL1	Loss of current setting on analogue input 1 with parameter 07.06 set at (4-20tr or 20-4tr)
28	CL2	Loss of current setting on analogue input 2 with parameter 07.11 set at (4-20tr or 20-4tr)
29	CL3	Loss of current setting on analogue input 3 with parameter 07.15 set at (4-20tr or 20-4tr)
30	SCL	Loss of serial link communication
31	EEF	EEPROM fault
32	Ph	Loss of power supply phase
33	rs	Fault during measurement of statoric resistance
40 to 49	tr xx	Specific user faults related to serial link

10.20 indicates the most recent fault.
10.29 indicates the most ancient fault.

10.30 : Maximum full power braking period

Range : 0,0 to 400,0s

Factory setting : 0s

This parameter defines the time during which the braking resistor is able to withstand maximum braking voltage (780V) without damage. It allows to set the time before tripping on braking overload.

10.31 : Interval between full power braking periods

Range : 0,0 to 25,0mn

Factory setting : 0mn

This parameter defines the time interval which must elapse between two consecutives full power braking periods as described with parameter 10.30. It is used to set the thermal time factor of the resistance. If this parameter is left at 0 then there will be no protection on the braking resistor.

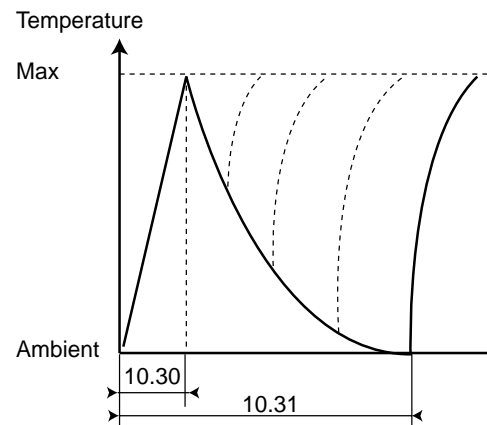

10.32 : External fault

Range : 0 or 1

This parameter is set at 1 when the " External fault" input is at 0.

If parameter 08.09 is set at 0, then " External fault" input corresponds to terminal 30.

If terminal 30 is used as " locking" input (08.09 = 1), it is possible to use another terminal as external fault input by inverting the signal to avoid tripping when the input is at 1.

Speed controller for asynchronous motors UMV 2301 AS

10.33 : Reset controller

Range : 0 or 1

Factory setting : 0

Switching from 0 to 1 of this parameter commands a reset of the controller.

If a remote fault clearance is necessary, a terminal must be assigned to this parameter.

If the controller trips on an IGBT overcurrent, either on the output bridge or the braking transistor, the controller cannot be reset at zero during 10 seconds (IGBT regeneration time).

10.34 : Number of automatic fault clearances

Range : 0 to 5

Factory setting : 0

0 : No automatic fault clearance. It should be commanded.

1 à 5 : Involve as many automatic fault clearances as the programmed number.

When the counter reaches the authorized number of automatic fault clearances, the controller is definitely locked. Clearance of this last fault must necessarily be commanded.

The counter is reset at zero when the fault which occurs is not similar to the previous one or when there is no fault during 5 minutes.

Automatic fault clearance is impossible on external fault (Et).

10.35 : Time delay of automatic fault clearance

Range : 0,0 to 25,0s

Factory setting : 1,0s

This parameter sets the time which must elapse between controller tripping and automatic clearance (provided minimum stop time for faults related to overcurrents is respected).

10.36 : Operational status maintained until definitive tripping

Range : 0 or 1

Factory setting : 0

0 : Parameter 10.01 (Controller status operational) is reset at zero each time the controller is tripping, without consideration for automatic fault clearances that might occur.

1 : Parameter 10.01 is kept at 1 during the trip phases which are automatically cleared

10.37 : Control of deceleration on minor faults

Range : 0 or 1

Factory setting : 0

1 : The controller will adjust deceleration before tripping on minor faults.

Minor faults are those which codes are between 16 and 26 inclusive.

0 : The controller trips instantaneously on minor faults. Deceleration is then obtained through coasting.

10.38 : Tripping on user faults

Range : 0 to 100

Factory setting : 0

This parameter is used to induce tripping on user faults, transmitted through the serial link.

Valid fault codes are 27 to 99, any value lower than 27 will refer to an already existing fault.

Trips released by the user will be displayed as trxx in the fault table, xx being the fault code.

User wishing to reset the controller at zero via the serial link can do it by setting this parameter at 100.

10.39 : Temperature image of braking resistor

Range : 0,0 to 100,0 %

This parameter gives an indication of the braking resistor temperature according to the model described before. A zero value means that the resistor is close to the ambient temperature and 100 % is maximum temperature (tripping level).

10.40 : Read status

Range : 0 to 32767

This parameter is used together with a serial communication interface. The value of this parameter is the sum of the controller bits planned for read only, with the following binary weights :

- 10.01 = 2^0 ,
- 10.02 = 2^1 ,
- 10.03 = 2^2 ,
- 10.04 = 2^3 ,
- 10.05 = 2^4 ,
- 10.06 = 2^5 ,
- 10.07 = 2^6 ,
- 10.08 = 2^7 ,
- 10.09 = 2^8 ,
- 10.10 = 2^9 ,
- 10.11 = 2^{10} ,
- 10.12 = 2^{11} ,
- 10.13 = 2^{12} ,
- 10.14 = 2^{13} ,
- 10.15 = 2^{14} .

Speed controller for asynchronous motors UMV 2301 AS



4.5.7 - MENU 12 : PROGRAMMABLE THRESHOLDS

4.5.7.1 - List over parameters in Menu 12

Parameter	Description	Type	Adjustment range	Unit	Factory setting	User setting
12.01	Threshold comparator 1 output	RO	0 or 1	-	-	-
12.02	Threshold comparator 2 output	RO	0 or 1	-	-	-
12.03	Threshold source comparator 1	R-W	0,00 to 20,50	Menu-parameter	0	
12.04	Threshold level comparator 1	R-W	0,0 to 100,0	%	0	
12.05	Threshold hysteresis comparator 1	R-W	0,0 to 25,0	%	0	
12.06	Output invert flag comparator 1	R-W	0 or 1		0	
12.07	Threshold destination comparator 1	R-W	0,00 to 20,50	Menu-parameter	0	
12.08	Not used					-
12.09	Not used					-
12.10	Not used					-
12.11	Not used					-
12.12	Not used					-
12.13	Threshold source comparator 2	R-W	0,00 to 20,50	Menu-parameter	0	
12.14	Threshold level comparator 2	R-W	0,0 to 100,0	%	0	
12.15	Threshold hysteresis comparator 2	R-W	0,0 to 25,0	%	0	
12.16	Output invert flag comparator 2	R-W	0 or 1		0	
12.17	Threshold destination comparator 2	R-W	0,00 to 20,50	Menu-parameter	0	

Speed controller for asynchronous motors UMV 2301 AS

4.5.7.2 - Block diagrams Menu 12

Symbols	
	Read and write
	Read only
	Read and assign

Threshold 1

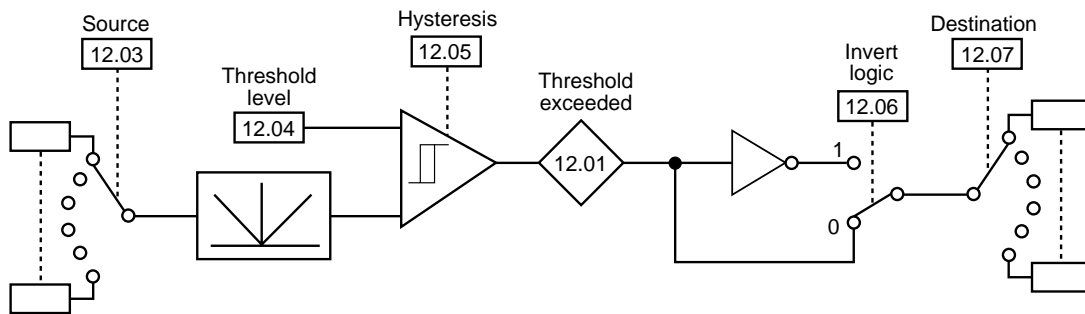

Threshold 2

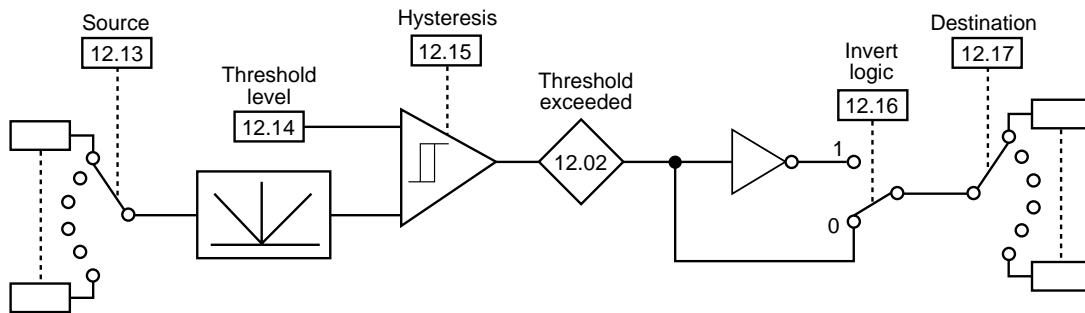

Speed controller for asynchronous motors UMV 2301 AS

4.5.7.3 - Description of parameters in menu 12

12.01 & 12.02 : Threshold comparator outputs

Range : 0 or 1

These parameters indicate whether the input variables are above (1) or below (0) the programmed thresholds.

12.01 : Output comparator 1.

12.02 : Output comparator 2.

12.03 & 12.13 : Threshold sources

Range : 0,00 to 20,50

Factory setting : 0

These parameters define which variable should be compared to the programmed thresholds.

The absolute value of the source variable is taken as input to the threshold comparator. Only non-bit parameters can be programmed as a source.

If a non valid parameter is programmed, the considered input value will be 0.

12.03 : Source comparator 1.

12.13 : Source comparator 2.

12.04 & 12.14 : Threshold levels

Range : 0,0 to 100,0 %

Factory setting : 0 %

These parameters are used for setting the switching thresholds of the comparators.

The thresholds are expressed as a percentage of the source maximum values.

12.04 : Threshold comparator 1.

12.14 : Threshold comparator 2.

12.05 & 12.15 : Threshold hysteresis

Range : 0,0 to 25,0 %

Factory setting : 0 %

These parameters define the band inside of which the comparator output will not switch.

The output will get to 1 when the variable reaches threshold value + (hysteresis \div 2).

The output will get to 0 when the variable value passes below threshold value - (hysteresis \div 2).

Hysteresis is expressed as a percentage of the source maximum value.

12.06 & 12.16 : Output invert flags

Range : 0 or 1

Factory setting : 0

These parameters are used to invert the threshold outputs of the comparators.

0 : Output not inverted.

1 : Output inverted.

12.06 : Output comparator 1 inverted.

12.16 : Output comparator 2 inverted.

12.07 & 12.17 : Threshold destination

Range : 0,00 to 20,50

Factory setting : 0

These parameters define the destination of the two programmable thresholds.

Only bit-type parameters can be programmed as threshold outputs.

If a non valid parameter is programmed, the output is not routed anywhere.

Speed controller for asynchronous motors UMV 2301 AS

4.5.8 - MENU 14 : PID CONTROL

4.5.8.1 - List over parameters in Menu 14

Parameter	Description	Type	Adjustment range	Unit	Factory setting	User setting
14.01	PID output	RO	±100	%	-	-
14.02	Source parameter of PID output	R-W	0,00 to 20,50	Menu-parameter	0	
14.03	PID reference input source	R-W	0,00 to 20,50	Menu-parameter	0	
14.04	PID feedback input source	R-W	0,00 to 20,50	Menu-parameter	0	
14.05	PID reference invert	R-W	0 or 1	-	0	
14.06	PID feedback invert	R-W	0 or 1	-	0	
14.07	PID reference slew rate limit	R-W	0 à 3200,0	s	0	
14.08	PID enable	R-W	0 or 1	-	0	
14.09	Optional PID enable source	R-W	0,00 to 20,50	Menu-parameter	0	
14.10	PID proportional gain	R-W	0 to 4,000	Factor	1,000	
14.11	PID integral gain	R-W	0 to 4,000	Factor	0,500	
14.12	PID derivative gain	R-W	0 to 4,000	Factor	0,000	
14.13	PID high limit	R-W	0 to 100,0	%	100,0	
14.14	PID low limit	R-W	± 100,0	%	-100,0	
14.15	PID scale factor	R-W	0,000 to 4,000	Factor	1,000	
14.16	PID output destination	R-W	0,00 to 20,50	Menu-parameter	0	
14.17	Hold integrator	R-W	0 or 1	-	0	

Speed controller for asynchronous motors UMV 2301 AS

4.5.8.2 - Block diagrams Menu 14

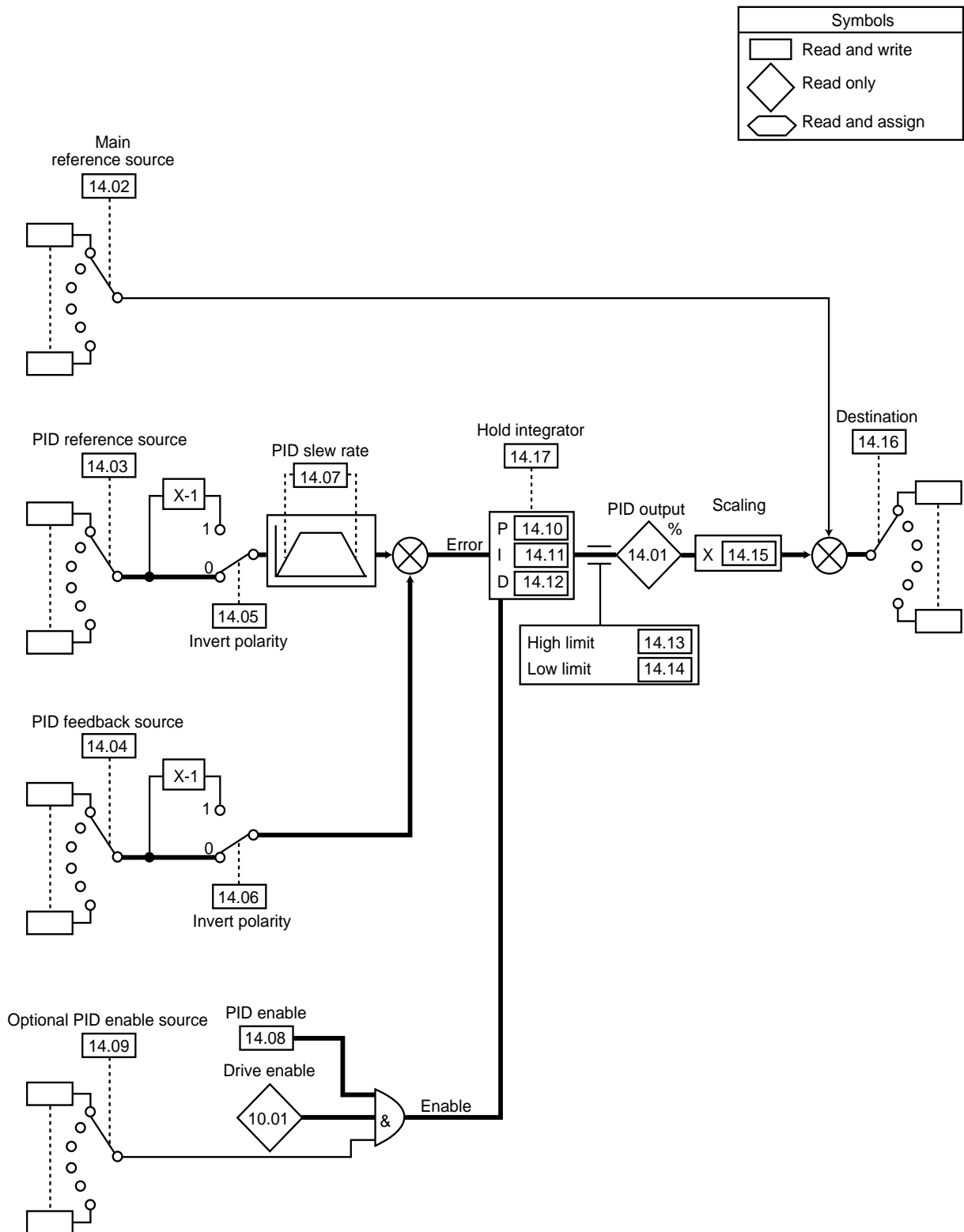

Speed controller for asynchronous motors UMV 2301 AS

4.5.8.3 - Description of parameters in menu 14

14.01 : PID output

Range : $\pm 100\%$

This parameter monitors the output level of the PID controller prior to scaling.

14.02 to 14.04 : PID input sources

Range : 0,00 to 20,50

Factory setting : 0

These parameters define which variables will serve as inputs to the PID controller.

Only non-bit parameters can be programmed as sources. If a non valid parameter is programmed the considered input value will be 0.

All PID variables will automatically be set to scale so they have a variation range of $\pm 100,0\%$ or $0 - 100,0\%$ if they are unipolar.

14.02 : Source parameter added to PID output in the destination.

14.03 : PID reference input.

14.04 : PID feedback input.

14.05 & 14.06 : Input invert bits

Range : 0 or 1

Factory setting : 0

These parameters are used to invert the sign of the PID reference and PID feedback.

0 : Input not inverted.

1 : Input inverted.

14.05 : PID reference invert.

14.06 : PID feedback invert.

14.07 : PID reference slew rate limit

Range : 0 to 3200,0 s

Factory setting : 0 s

This parameter sets the time necessary for the PID reference to ramp from 0 to 100,0 % after a sudden 0 to 100 % step change in input. Changes from -100,0 % to +100,0 % will require twice this time.

14.08 : PID enable

Range : 0 or 1

Factory setting : 0

This parameter must be set to 1 for the PID controller to operate.

If this parameter is set to 0, PIDoutput will be 0.

14.09 : Optional PID enable source

Range : 0,00 to 20,50

Factory setting : 0

This parameter allows to enable the PID controller with an additional condition to 14.08.

To enable the PID controller, 14.08, 10.01 as well as this optional condition must be set to 1.

Only bit parameters can be programmed.

If a non valid parameter is programmed the input will automatically be 1 to prevent locking of the enable output.

14.10 : PID proportional gain

Range : 0 to 4,000

Factory setting : 1,000

It is the proportionnal gain applied to the PID error.

14.11 : PID integral gain

Range : 0 to 4,000

Factory setting : 0,500

It is the gain applied to the PID error before being integrated.

14.12 : PID derivative gain

Range : 0 to 4,000

Factory setting : 0,000

It is the gain applied to the PID error before being differentiated.

14.13 : PID high limit

Range : 0 to 100,0 %

Factory setting : 100,0 %

This parameter allows to limit the maximum positive value of the PID output.

14.14 : PID low limit

Range : $\pm 100,0\%$

Factory setting : -100,0 %

This parameter allows to limit the maximum negative value or the minimum positive value of the PID output.

14.15 : PID scale factor

Range : 0,000 to 4,000

Factory setting : 1,000

This parameter allows to set the PID output to scale before being added to the main reference.

After addition, the output will automatically be scaled again to match the variation range of the destination parameter.

14.16 : PID output destination

Range : 0,00 to 20,50

Factory setting : 0

This parameter allows to define to which parameter the PID output is addressed.

Only unprotected non-bit parameters can be controlled.

If a non valid parameter is programmed the output is not routed anywhere.

If the PID is to control speed, then it is recommended to enter one of the preset speed parameters here.

If the PID is to trim speed, then it is recommended to enter the offset parameter (01.04) here.

14.17 : Hold integrator

Range : 0 or 1

Factory setting : 0

0 : Integrator is reset to 0 each time the PID loop is disabled.

1 : The integrator value is held each time the PID loop is disabled.

Speed controller for asynchronous motors UMV 2301 AS

5 - FAULTS - DIAGNOSIS

– Informations related to controller status are given on the display, or by logic outputs (relays and transistors with open commutator) for certain statuses.

– These informations can be :

- controller status
- alarm flags during controller
- faults displayed in a mnemonic form

5.1 - Display of drive trip codes

N°	Mnemonic display	Trip cause	Check points	Solution
1	UU	DC bus undervoltage	<ul style="list-style-type: none"> • Power supply terminals L1, L2, L3 / mains undervoltage 	<ul style="list-style-type: none"> • Check mains power supply • Check power components
2	OU	DC bus overvoltage	<ul style="list-style-type: none"> • Deceleration too fast (inertial load) • Terminals L1, L2, L3 / mains undervoltage 	<ul style="list-style-type: none"> • Program longer deceleration time in 00.04 • Check deceleration mode in 00.15 • Fit a braking resistor (optional) • Check mains power supply
3	OI. AC	Overcurrent at controller output	<ul style="list-style-type: none"> • Power terminal blocks U, V, W • Wiring 	<ul style="list-style-type: none"> • Eliminate short-circuit at controller output • Program longer acceleration time in 00.03
4	OI. br	Overcurrent braking resistor	<ul style="list-style-type: none"> • Power terminal blocks +, •, – • Braking resistor, value 	<ul style="list-style-type: none"> • Eliminate short-circuit at resistor output • Increase resistor ohmic value
5	PS	Internal power supply faulty	<ul style="list-style-type: none"> • Terminals + 10V and + 24V 	<ul style="list-style-type: none"> • Check that load on + 10V and + 24V is compatible with maximum flow • Eliminate short-circuit on + 10V or + 24V terminal
6	Et	Forced external fault	<ul style="list-style-type: none"> • Terminal 30 in open loop mode 	<ul style="list-style-type: none"> • Check that terminal 30 is connected to 0 V by external wiring (negative logic)
7	OV. Spd	Overspeed	<ul style="list-style-type: none"> • Motor speed higher than set speed 	<ul style="list-style-type: none"> • Check that the load is not driving • Adjust speed loop gains
19	it. br	Overload braking resistor	<ul style="list-style-type: none"> • Braking resistor • Braking resistor wiring • Integrated braking resistor • Braking cycle too important 	<ul style="list-style-type: none"> • Increase ohmic value • Check wiring • Check braking transistor • Increase braking cycle
20	it. AC	Motor overload I x t	<ul style="list-style-type: none"> • Motor load • Adjustment of IN motor 	<ul style="list-style-type: none"> • Check that motor is not overloaded • Check that motor rated current is correctly set (00.46)
21	Oh 1	Thermal simulation of heat sink depending on I x t	<ul style="list-style-type: none"> • Adjustment of IN motor 	<ul style="list-style-type: none"> • Reduce motor load • Reduce cycle
22	Oh 2	Heat sink overheating detected by thermal probe (over 90°C)	<ul style="list-style-type: none"> • cooling ventilator (if fitted) • Ambient temperature 	<ul style="list-style-type: none"> • Check that : <ul style="list-style-type: none"> - ventilators are spinning - cooling louvres are not obstructed - temperature is lower than 50°C - there is enough clearance around controller
23	OA	Control card overheating		
24	th	Motor thermal probe trip	<ul style="list-style-type: none"> • Motor temperature too high : PTC > 3 kΩ or OTP open • Reset for R < 1,65kΩ 	<ul style="list-style-type: none"> • Check motor load • Reduce overload level • Check motor ventilation and ambient temperature • Check probe wiring

Speed controller for asynchronous motors UMV 2301 AS

N°	Mnemonic display	Trip cause	Check points	Solution
25	thS	Short-circuit on motor thermal probe PTC (terminal 8) with input configured in THS	• PTC motor < 4 Ω	• Check probe ohmic value
26	OP.OVLd	Overload on + 24V power supply or digital outputs	• Terminal + 24V	• Check + 24V charging circuit
27	CL1	Loss of current setting on analogue input 1 with parameter 0.31 set at (4-20tr or 20-4tr)	• Level of current setting 4.20 mA or 20.4 mA	• Check that current setting is > 3mA
28	CL2	Loss of current setting on analogue input 2 with parameter 7.11 set at (4-20tr ou 20-4tr)		
29	CL3	Loss of current setting on analogue input 3 with parameter 7.15 set at (4-20tr ou 20-4tr)		
30	SCL	Loss of serial link communication	• Optional serial link card COM 1 UMV • PC link	• Power down and then power up • Check mounting and connection of card • Transmission rate
31	EEF	EEPROM fault	• Control card	• Power down and then power up • If the fault remains, ask LEROY-SOMER
32	Ph	Loss of a power supply phase	• L1, L2, L3	• Check the mains (motor stops before fault is displayed)
33	rs	Trip during measurement of statoric resistance	• Matching of motor power with controller power	• Adapt controller power to motor power
40 to 49	tr xx	Specific user faults with serial link	• Fault	• Check trip cause

Note : thermal components should not be reset several times consecutively.

5.2 - Display of controller status

Display	Output state	Operation
rdY	Inactive	The controller awaits a command Motor is ready to function
run	Active	Motor is controlled
inh	Inactive	Coast stop
SCAN	Active	catch spinning motor after microcut
ACUU	Active	Loss of mains power supply and controller keeps on supplying the motor
dEC	Active	Deceleration after stop command
triP	Inactive	Controller trip. Trip code is displayed

Note : the displays above are not trip codes, but inform about the controller status.

5.3 - Display of controller alarms

br.rs	Braking resistor overheating
OVLd	Motor overload I x t
hot	Heat sink overheating
Air	Excessive control card temperature

Note : when an alarm is displayed, the controller keeps on driving and the lower display alternatively shows the normal message and the alarm code.

5.4 - Logic output signal

Terminal	Type of output	Information given as standard
1	Relay	Fault indication
2		

Speed controller for asynchronous motors UMV 2301 AS

6 - MAINTENANCE

6.1 - Introduction and advice

⚠ All work related to controller installation, commissioning and maintenance must be carried out by experienced and qualified personnel.

When a fault detected by the controller causes it to power down, residual voltages which may be fatal remain at the controller terminals and inside of it.

Do not carry out any work before the controller power supply has been opened and locked, and wait 10 mn until the capacitors have discharged.

Make sure that the DC bus voltage is lower than 40 V before any intervention.

During maintenance operation with the controller powered-up, the personnel must stand on an insulating surface not connected to earth.

During work on a motor or its power supply cables, make sure that the power supply of the corresponding controller has been opened and locked.

During tests, all protective covers must be kept in place.

Maintenance and emergency repairs of the UMV 4301 controller to be carried out by the user are extremely few and simple. Ordinary service operations as well as simple methods for testing correct controller function are described hereafter.

6.2 - Service

Any controller may be subject to problems after being exposed to excessive heat, humidity, oil, dust, or if any external matter is allowed to penetrate.

Normally the printed circuits and their components do not require any maintenance. In the event of a problem, get in touch with your nearest supplier or approved service center.

DO NOT REMOVE PRINTED CIRCUIT BOARDS DURING WARRANTY PERIOD. IT WOULD IMMEDIATELY BECOME NULL AND VOID.

Do not touch integrated circuits or the microprocessor with your fingers or any charged or live material. You should be earthed, as well as the workbench or the soldering iron, before any operation on the circuits.

Check periodically that the power connections are correctly tightened.

Tightening torque :

- UMV 2301 AS 8T to 16T = 0,5 Nm,
- UMV 2301 AS 22T to 120T = 25 Nm.

6.3 - Voltage, current and power measurements

6.3.1 - Measurement of controller output voltage

Due to the harmonics generated by the controller it is not possible to make a correct measurement of the motor input voltage with a standard voltmeter. It is however possible to measure an approximate value of the fundamental wave effective voltage (the one which influences torque) with an ordinary voltmeter connected as shown below.

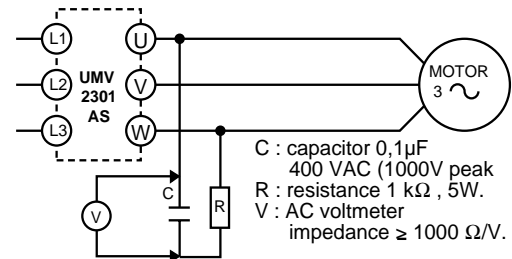

6.3.2 - Measurement of motor current

The current drawn by the motor and the controller input current can be approximately measured with an ordinary moving coil ammeter.

6.3.3 - Measurement of controller input and output power

The controller input and output powers can be measured with an electro-dynamic instrument.

6.4 - Spare parts list

Ask LEROY-SOMER

6.5 - Replacement of products

WARNING :

The products must be sent back in their original packing or at least in a similar packing in order to avoid any damage. Otherwise the warranty could be refused.

Speed controller for asynchronous motors UMV 2301 AS

7 - OPERATING EXTENSIONS

7.1 - Serial link option



• The option module should be installed or removed only after the controller has been powered down and isolated.

This option fits inside of the UMV 2301 AS controller.

- COM 1 UMV : "slow" serial link RS 232 - RS 485 - ANSI protocole.

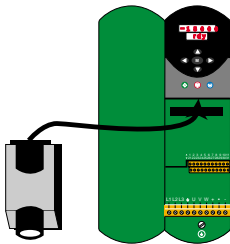

7.2 - RF braking resistors



Precautions should be observed when using measuring instruments close to the braking resistors, because of the present temperatures and voltages.

- The braking resistors must be series connected with a thermal relay calibrated for the effective resistor current in order to avoid outbreak of fire further to a malfunction of the braking transistor or a short-circuit.

• Never connect the resistance directly between the + and - terminals of the controller.

Peak power depends on the DC bus voltage. In the following tables, it has been calculated with 720V.

7.2.1 - Specifications

- RF 320 T to 55000 T with mains at 400 V $\pm 10\%$

RF	Resistance (Ω)	Thermal power (KW)	Peak power (KW)	Rms current (A)*
320 T	180	320	2880	1,33
640 T	90	640	5760	2,66
1000 T	68	1000	7620	3,8
2000 T	40	2000	12960	7,07
3500 T	40	3500	12960	9,35
5500 T	40	5500	12960	11,7
7500 T	10	7500	51840	27,4
11000 T	10	11000	51840	33,2
18500 T	10	18500	51840	43
22500 T	5	22500	103680	67
27500 T	10	27500	51840	52,4
37500 T	5	37500	103680	86,6
55000 T	5	55000	103680	104,8

* Adjustment current of the thermal relay series coupled inside the resistor.

- Minimal compatible resistance

UMV 2301 AS controller rating	Minimal ohmic value (Ω)	Peak current (A)
8T to 16T	40	20
22T to 50T	10	75
60T to 120T	5	150

7.2.2 - Mechanical specifications

- RF 320 T to 3500 T

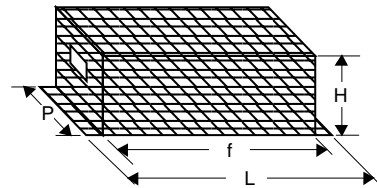

RF	Weight (kg)	Dimensions L x l x h (mm)	Fastening centre distance F (mm)
320 T	1,5	425 x 134 x 114	395
640 T	2,1	425 x 134 x 114	395
1000 T	3,6	565 x 224 x 180	535
2000 T	5,1	565 x 224 x 180	535
3500 T	7,5	565 x 370 x 180	535

- RF 5500 T to 55000 T

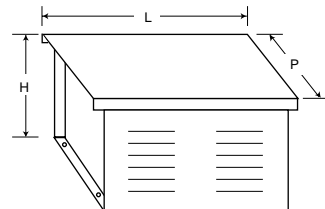

RF	L	P	H
5500 T	520	480	330
7500 T	520	480	330
11000 T	670	480	480
18500 T	970	580	480
22500 T	670	480	630
27500 T	670	480	630
37500 T	970	580	710
55000 T	970	580	860

Speed controller for asynchronous motors UMV 2301 AS

7.3 - R.F.I. filters

They are used to reduce electromagnetic emissions from the controller and thus to comply with European standards EN-50081-2 over all the available switching frequency range.

• Combination

UMV 2301 AS rating	Filter reference
8 T to 16T	FLT 3027
22T to 33T	FLT 1051
40 T	FLT 1071
50T to 60T	FLT 1111
75T to 120T	FLT 1171

• Specifications

Reference	FLT 3027
Rated current (A)	27
Overload	150% of I_n during 60s
Power supply voltage	Between phases : 480V $\pm 10\%$ 50-60 Hz Between phases and earth : 480V - 0 %
Leakage current *	7,4mA at 400V 50Hz balanced voltage 58mA at 400V one phase disconnected

Reference	FLT 1051	FLT 1071	FLT 1111	FLT 1171
Rated current (A)	50	70	110	170
Overload	150% of I_n during 60s			
Power supply voltage	Between phases : 480V $+10\%$ 50-60 Hz Between phases and earth : 500V $+ 0\%$			
Leakage current *	55mA at 400V 50Hz balanced voltage 320mA at 400V one phase disconnected			

* Proportional to power supply voltage and frequency

• Dimensions

- FLT 3027

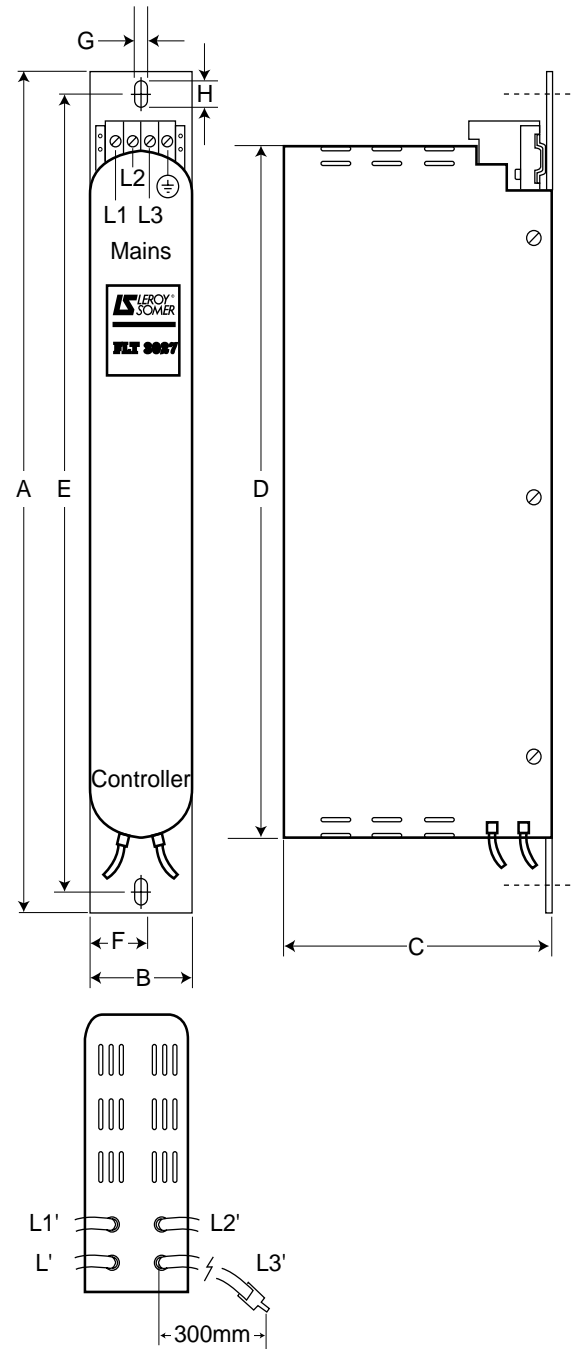

Filter reference	Dimensions (mm)								Weight (kg)
	A	B	C	D	E	F	G	H	
FLT 3027	396	75	113	335	377,5	37,5	6,5	10,5	2,7

Speed controller for asynchronous motors UMV 2301 AS

- FLT 1051 to FLT 1171

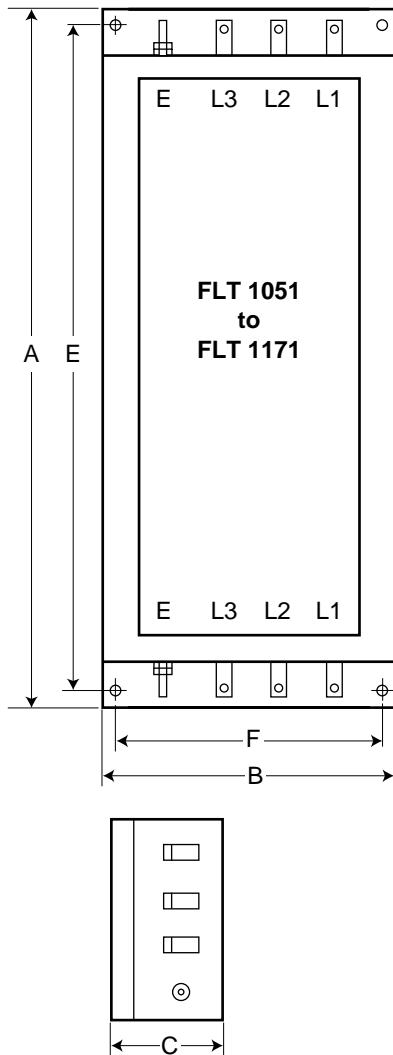

Filter reference	Dimensions (mm)					Weight (kg)
	A	B	C	D	E	
FLT 1051	330	190	145	305	160	7,5
FLT 1071	330	190	145	305	160	10,4
FLT 1111	440	220	145	400	170	13
FLT 1171	490	220	145	400	170	15

7.4 - Three-phase chokes for attenuation of leakage currents : Self MC

These are directly connected at controller output (U, V, W terminals) and help reduce leakage currents as well as interference.

They are cylindrical in shape and are fastened through a central unthreaded hole.

Self MC rating	UMV 2301 AS rating	Dimensions (mm)			Weight (kg)
		Diameter	Height	Ø hole	
11T	8T to 11T	50	50	5,1	0,75
27T	16T to 27T	125	55	6,2	1,9
50T	33T to 50T	125	65	6,2	3
75T	60T to 75T	145	90	8,3	4,5
120T	100T to 120T	220	120	10 x 25	8

• Wiring

Self MCchokes are fitted as close to the controller as possible according to the wiring diagram hereunder.

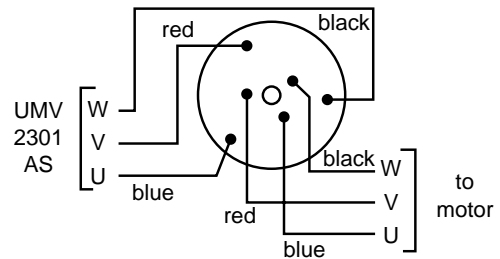

**Speed controller for
asynchronous motors
UMV 2301 AS**

Notes

Speed controller for asynchronous motors UMV 2301 AS

8 - SUMMARY OF SETTINGS FOR YOUR APPLICATION

UMV type	Rating	Software	Serial nr.	Motor type	Motor nr.	Option	Commissioning

Parameter	Description	Factory setting	Parameter set on :	Parameter set on :
-----------	-------------	-----------------	--------------------	--------------------

Menu 0

00.00	Memorization Factory Settings Access code to other menus	0		
00.01	Minimum frequency clamp	0.0 Hz		
00.02	Maximum frequency clamp	50.0 Hz		
00.03	Acceleration ramp	60.0s/100Hz		
00.04	Deceleration ramp	60.0s/100Hz		
00.05	Select speed references	0		
00.06	Current limits	120 %		
00.07	Select control mode	Ur1		
00.08	Starting torque (Boost)	3.0 %		
00.09	Select dynamic V to F mode	1		
00.15	Select deceleration mode	Std.Ct		
00.16	Select stop mode	rp		
00.18	Select linear ramp / S ramp	0		
00.19	S ramp rate	450.0 s ²		
00.20	Frequency skip 1	0.0		
00.21	Frequency skip band 1	0.5 Hz		
00.22	Frequency skip 2	0.0		
00.23	Frequency skip band 2	0.5 Hz		
00.24	Preset frequency 1	0.0 Hz		
00.25	Preset frequency 2	0.0 Hz		
00.26	DC bus regulation voltage threshold	700 V		
00.27	Current loop proportional gain	20		
00.28	Current loop integral gain	40		
00.30	Stator resistance	0.000 Ω		
00.31	Type of signal, analogue input 1	Volt		
00.34	User security code	149		
00.35	Serial link : 2-wire mode	0		
00.36	Serial link transmission rate	4800 Bauds		
00.37	Serial link controller address	1.1		
00.38	Parameter displayed on power-up	0.10		
00.39	Catch spinning motor	1		
00.40	Self-calibration	0		
00.41	Switching frequency *	3 kHz		
00.42	Motor pole number	4 poles		
00.43	Power factor (cos φ)	0.850		
00.44	Motor rated voltage	400 V		
00.45	Motor rated speed	0		
00.46	Motor rated current	IN. VARIATEUR		
00.47	Motor rated frequency	50.0 Hz		
00.48	Controller operating mode	HVAC		
00.49	Security status	0 / 0 / 1		



Speed controller for asynchronous motors UMV 2301 AS

Parameter	Description	Factory setting	Parameter set on :	Parameter set on :
Frequency reference				
01.14	Select frequency references	0		
01.21	Preset frequency 1 or faster / slower reference	0		
01.22	Preset frequency 2	0		
01.23	Preset frequency 3	0		
01.24	Preset frequency 4	0		
01.25	Preset frequency 5	0		
01.26	Preset frequency 6	0		
01.27	Preset frequency 7	0		
01.28	Preset frequency 8	0		
Fault processing				
06.02	Start mode	0 (diS)		
06.03	Mains loss mode	0 (diS)		
06.09	Catch spinning motor	1		
Assignment of analogue outputs				
07.19	Sources analogue output 1	05.01		
07.22	Sources analogue output 2	04.02		
Assignment of logic inputs / outputs				
08.10	Destination / source of terminal 24	10.06		
08.12	Select input / output terminal 24	1		
08.13	Destination / source of terminal 25	10.33		
08.15	Select input / output terminal 25	0		
08.16	Destination / source of terminal 26	01.45		
08.18	Select input / output terminal 26	0		
08.21	Terminal 28 input destination	06.32		
08.23	Terminal 29 input destination	01.42		
Faster / slower				
09.21	Select automatic reset of faster / slower reference	0		
09.22	Select polarity of faster / slower reference	0		
09.23	ARamp rate of faster / slower reference	20		
09.25	Destination of faster / slower reference	0		
PID control				
14.07	PID slew rate	0		
14.08	PID enable	0		
14.09	Optional PID enable source	0		
14.10	PID proportional gain	1,000		
14.11	PID integral gain	0,500		
14.12	PID derivative gain	0,000		
14.13	PID high limit	100,0		
14.14	PID low limit	-100,0		
14.15	PID scale factor	1,000		
14.16	PID output destination	0		
14.17	Hold integrator	0		

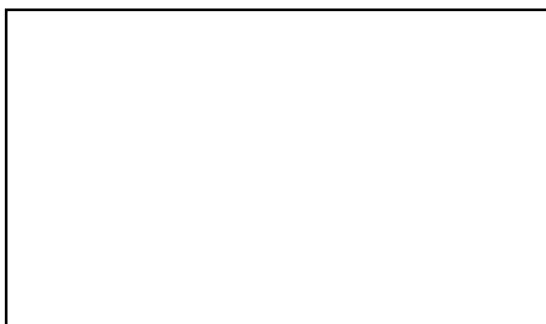

MOTEURS LEROY-SOMER 16015 ANGOULEME CEDEX-FRANCE