

Installation Guide

COMMANDER *Gp*

model sizes 1 to 4

0.75kW to 110kW
(1HP to 150HP)

COMMANDER *GpLV*

model sizes 1 to 3

0.37kW to 22kW
(0.5HP to 30HP)

General Purpose Variable Speed Drive
for induction motors

Part Number: 0451-0021

Issue Number: 2

General information

The manufacturer accepts no liability for any consequences resulting from inappropriate, negligent or incorrect installation or adjustment of the optional operating parameters of the equipment or from mismatching the variable speed drive (Drive) with the motor.

The contents of this Installation Guide are believed to be correct at the time of printing. In the interests of a commitment to a policy of continuous development and improvement, the manufacturer reserves the right to change the specification of the product or its performance, or the contents of the Installation Guide, without notice.

All rights reserved. No parts of this Installation Guide may be reproduced or transmitted in any form or by any means, electrical or mechanical including photocopying, recording or by any information-storage or retrieval system, without permission in writing from the publisher.

Important...

Drive software version

This product is supplied with the latest version of user-interface and machine-control software. If this product is to be used with other Control Techniques variable speed drives in an existing system, there may be some differences between their software and the software in this product. These differences will cause a difference in functions. This may also apply to variable speed drives returned from a Control Techniques Service Centre.

If there is any doubt, contact a Control Techniques Drive Centre.

| | |
|--------------|--|
| Copyright | © March 2000 Control Techniques Drives Ltd |
| Author: | RFD |
| Issue Code: | gpiu2 |
| Issue Date: | March 2000 |
| S/W Version: | 03.XX.XX |

Contents

Chapter

| | | |
|----------|--|------------|
| 1 | Safety Information | 1-1 |
| 1.1 | Warnings, Cautions and Notes | 1-1 |
| 1.2 | Electrical safety – general warning | 1-1 |
| 1.3 | System design | 1-1 |
| 1.4 | Environmental limits | 1-1 |
| 1.5 | Compliance with regulations | 1-1 |
| 1.6 | Safety of personnel | 1-1 |
| 1.7 | Risk analysis | 1-2 |
| 1.8 | Motor | 1-2 |
| 1.9 | Adjusting parameters | 1-2 |
| 2 | Installing the Drive | 2-1 |
| 2.1 | Environmental requirements | 2-1 |
| 2.2 | EMC considerations | 2-2 |
| 2.3 | Planning the installation | 2-3 |
| 2.4 | Calculating the enclosure size | 2-15 |
| 2.5 | Installing the Drive and RFI filter | 2-17 |
| 2.6 | Power connections | 2-31 |
| 2.7 | Wiring recommendations | 2-34 |
| 2.8 | Variations in the EMC wiring recommendations | 2-40 |
| 2.9 | Signal connections | 2-41 |

Appendix

| | | |
|----------|-----------------------------------|------------|
| A | Motor Connections | A-1 |
| A.1 | Cable length | A-1 |
| A.2 | Multiple motors | A-1 |
| B | UL Listing Information | B-1 |
| B.1 | AC supply specification | B-1 |
| B.2 | Maximum continuous output current | B-1 |
| C | Data | C-1 |
| C.1 | Drive | C-1 |
| C.2 | Optional RFI filters | C-7 |

Declaration of Conformity

Control Techniques Limited
The Gro
Newtown
Powys
UK
SY16 3BE

These products comply with the Low Voltage Directive 73/23/EEC, the Electromagnetic Compatibility (EMC) Directive 89/336/EEC and the CE Marking Directive 93/68/EEC.

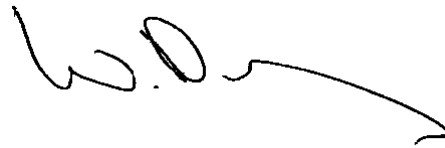

W. Drury
Executive VP Technology
Newtown

Date: 13th March 2000

| | | | | |
|----------|----------|----------|----------|----------|
| GPD 1401 | GPD 1402 | GPD 1403 | GPD 1404 | GPD 1405 |
| GPD 2401 | GPD 2402 | GPD 2403 | | |
| GPD 3401 | GPD 3402 | GPD 3403 | GPD 3404 | GPD 3405 |
| GPD 4401 | GPD 4402 | GPD 4403 | GPD 4404 | GPD 4405 |
| GPD 1201 | GPD 1202 | GPD 1203 | GPD 1204 | GPD 1205 |
| GPD 2201 | GPD 2202 | GPD 2203 | | |
| GPD 3201 | GPD 3202 | GPD 3203 | GPD 3204 | |

The AC variable speed drive products listed above, have been designed and manufactured in accordance with the following European harmonised, national and international standards:

| | |
|------------------------|--|
| EN60249 | Base materials for printed circuits |
| IEC326-1 | Printed boards: general information for the specification writer |
| IEC326-5 | Printed boards: specification for single- and double-sided printed boards with plated-through holes |
| IEC326-6 | Printed boards: specification for multilayer printed boards |
| IEC664-1 | Insulation co-ordination for equipment within low-voltage systems: principles, requirements and tests |
| EN60529 | Degrees of protection provided by enclosures (IP code) |
| UL94 | Flammability rating of plastic materials |
| UL508C | Standard for power conversion equipment |
| EN50081-1 ¹ | Generic emission standard for the residential, commercial and light industrial environment |
| EN50081-2 | Generic emission standard for the industrial environment |
| EN50082-2 | Generic immunity standard for the industrial environment |
| EN61800-3 | Adjustable speed electrical power drive systems – Part 3: EMC product standard including specific test methods |

These electronic Drive products are intended to be used with appropriate motors, controllers, electrical protection components and other equipment to form complete end products or systems. Compliance with safety and EMC regulations depends upon installing and configuring Drives correctly, including using the specified input filters. The Drives must be installed only by professional assemblers who are familiar with requirements for safety and EMC. The assembler is responsible for ensuring that the end product or system complies with all the relevant laws in the country where it is to be used. Refer to the Installation Guide. A Commander GP EMC Data Sheet is also available giving detailed EMC information.

¹ Conducted emission sizes 1 to 3, not size 4. See the relevant EMC Data Sheet.

1 Safety Information

1.1 Warnings, Cautions and Notes

A **Warning** contains information which is essential for avoiding a safety hazard.

A **Caution** contains information which is necessary for avoiding a risk of damage to the product or other equipment.

A **Note** contains information which helps to ensure correct operation of the product.

1.2 Electrical safety – general warning

The voltages used in the Drive can cause severe electric shock and/or burns, and could be lethal. Extreme care is necessary at all times when working with or adjacent to the Drive.

Specific warnings are given at the relevant places in this Installation Guide and the accompanying User Guide.

The installation must comply with all relevant safety legislation in the country of use.

1.3 System design

The Drive is intended as a component for professional incorporation into complete equipment or systems. If installed incorrectly the Drive may present a safety hazard. The Drive uses high voltages and currents, carries a high level of stored electrical energy, and is used to control mechanical equipment which can cause injury.

Close attention is required to the electrical installation and the system-design to avoid hazards either in normal operation or in the event of equipment malfunction. System-design, installation, commissioning and maintenance must be carried out by personnel who have the necessary training and experience. They must read this safety information and this Installation Guide carefully.

To ensure mechanical safety, additional safety devices such as electro-mechanical interlocks may be required. The Drive must not be used in a safety-critical application without additional high-integrity protection against hazards arising from a malfunction.

1.4 Environmental limits

Instructions in this Installation Guide regarding transport, storage, installation and use of Drives must be complied with, including the specified environmental limits. Drives must not be subjected to excessive physical force.

1.5 Compliance with regulations

The installer is responsible for complying with all relevant regulations, such as national wiring regulations, accident prevention regulations and electromagnetic compatibility (EMC) regulations. Particular attention must be given to the cross-sectional areas of conductors, the selection of fuses or other protection, and protective earth (ground) connections.

This Installation Guide contains instructions for achieving compliance with specific EMC standards.

Within the European Union, all machinery in which this product is used must comply with the following directives:

98/37/EC: Safety of Machinery

89/336/EEC: Electromagnetic Compatibility.

1.6 Safety of personnel

The STOP function of the Drive does not remove dangerous voltages from the output of the Drive or from any external option unit.

The Stop and Start controls or electrical inputs of the Drive must not be relied upon to ensure safety of personnel. If a safety hazard could exist from unexpected starting of the Drive, an interlock that electrically isolates the Drive from the AC supply must be installed to prevent the motor being inadvertently started.

Careful consideration must be given to the functions of the Drive which might result in a hazard, either through their intended functions (eg. Auto-start) or through incorrect operation due to a fault or trip (eg. stop/start, forward/reverse, maximum speed).

Under certain conditions, the Drive can suddenly discontinue control of the motor. If the load on the motor could cause the motor speed to be increased (eg. hoists and cranes), a separate method of braking and stopping the motor must be used (eg. a mechanical brake).

Before connecting the AC supply to the Drive, it is important that you understand the operating controls and their operation. If in doubt, do not adjust the Drive. Damage may occur, or lives put at risk. Carefully follow the instructions in this Installation Guide.

Before making adjustments to the Drive, ensure all personnel in the area are warned. Make notes of all adjustments that are made.

1.7 Risk analysis

In any application where a malfunction of the Drive could lead to damage, loss or injury, a risk analysis must be carried out, and where necessary, further measures taken to reduce the risk. This would normally be an appropriate form of independent safety back-up system using simple electro-mechanical components.

1.8 Motor

Ensure the motor is installed in accordance with the manufacturer's recommendations. Ensure the motor shaft is not exposed.

Standard squirrel-cage induction motors are designed for single-speed operation. If it is intended to use the capability of the Drive to run a motor at speeds above its designed maximum, it is strongly recommended that the manufacturer is consulted first.

Low speeds may cause the motor to over-heat because the cooling fan becomes less effective. The motor should then be fitted with a protection thermistor. If necessary, a separate cooling fan should be used.

If a Drive is to be used to control a number of motors, special measures need to be taken to ensure protection of the motors; refer to *Motor protection* in Appendix A *Motor Information*.

1.9 Adjusting parameters

Some parameters have a profound effect on the operation of the Drive. They must not be altered without careful consideration of the impact on the controlled system. Measures must be taken to prevent unwanted changes due to error or tampering.

2 Installing the Drive



Warning

Adhere to the instructions

The mechanical and electrical installation instructions must be adhered to. Any questions or doubt should be referred to the supplier of the equipment. It is the responsibility of the owner or user to ensure that the installation of the Drive and any external option unit, and the way in which they are operated and maintained, comply with the requirements of the Health and Safety at Work Act in the United Kingdom or applicable legislation and regulations and codes of practice in the country in which the equipment is used.



Warning

Competence of the installer

The Drive must be installed only by professional assemblers who are familiar with the requirements for safety and EMC. The assembler is responsible for ensuring that the end-product or system complies with all the relevant laws in the country where it is to be used.

2.1 Environmental requirements



Warning

Installation in an enclosure

The Drive must be protected against water, condensation and electrically conductive contamination. When the gland plate and appropriate glands are fitted, the Drive can attain ingress protection to NEMA 1 and IP40 (in accordance with IEC529). UL listing is valid when the Drive is installed in a type 1 enclosure as defined in UL 50.



Warning

Authorized access

The enclosure should prevent access by anyone except for authorized, trained service personnel.



Warning

Fire enclosure

The Drive case is not classified as a fire enclosure. When this protection is required, the Drive should be installed in a fire enclosure.



Warning

Hazardous areas

The Drive must not be located in a classified hazardous area unless the Drive is installed in an approved enclosure and the installation is certified.



Warning

Before a Commander GP size 3 or 4 is used as a motoring Drive in a Regen application, the Drive must be modified. Contact the supplier of the Drive for details.

1. Refer to Appendix C *Data* for details of the environmental requirements.
2. If condensation is likely to occur when the Drive is not in use, an anti-condensation heater must be installed. This heater must be switched off when the Drive is in use; automatic switching is recommended.
3. If the Drive is to be mounted directly above any heat-generating equipment (such as another Drive), the maximum temperature of the air immediately below the Drive should be taken as the ambient temperature for the Drive.
4. If the Drive is to be mounted beneath other equipment, such as another Drive, the Drive should not cause the ambient temperature requirements of the equipment to be exceeded.
5. When compliance with EMC emission standards is required, the enclosure must be made of metal but does not require special EMC features.

UL-listing requirements are given in Appendix B.

2.2 EMC considerations

Depending on the requirements of the installation, one of the following levels of electromagnetic compatibility (EMC) should be adopted:

Routine EMC precautions

These precautions are recommended when strict compliance with emission standards is not required. The risk of disturbing adjacent electronic equipment is minimized by adopting these precautions.

Compliance with EMC emission standards

These precautions are recommended when strict compliance with emission standards is required. In addition, it is recommended that these precautions are taken when the Drive is installed in a residential area, or adjacent to sensitive electronic equipment such as radio receivers or similar.

Compliance with EN61800-3 (standard for Power Drive Systems)

Meeting the requirements of this standard depends on the environment that the Drive is intended to operate in, as follows:

Operation in the first environment

Observe the guidelines given in *Compliance with EMC emission standards*. An RFI filter will always be required. Some model sizes may require additional filtering techniques to be applied.

Operation in the second environment

An RFI filter may not be required. Follow the guidelines given in *Routine EMC precautions* or *Compliance with EMC emission standards* depending on the requirements of the end user.



Caution

The second environment typically includes an industrial low-voltage power supply network which does not supply buildings used for domestic purposes. Operating the Drive in this environment without an RFI filter may cause interference to nearby electronic equipment whose sensitivity has not been appreciated. The user must take remedial measures if this situation arises. If the consequences of unexpected disturbances are severe, it is recommended that the emission limits of EN50081-2 be adhered to.

Instructions are given later in this chapter for these levels of EMC. Refer to Appendix C *Data* for further information on compliance with EMC standards and definitions of environments.

Detailed instructions and EMC information are given in the *Commander GP EMC Data Sheet* which is available from the Drive Centres and distributors listed at the end of the *User Guide*.

Compliance data is given in Appendix C *Data*.

Note

The installer of the Drive is responsible for ensuring compliance with the EMC regulations that apply where the Drive is to be used.

The Drive will comply with the standards for emission, such as EN50081-2, only when the instructions given in *Planning the installation* and *Wiring recommendations* later in this chapter are followed closely.



Warning

Special consideration is needed if the filter is to be used in movable equipment where the ground is connected through a flexible cable and plug/socket. Additional measures such as a supplementary ground connection or ground continuity monitoring will be required.

2.3 Planning the installation

Instructions in numbered steps

The instructions in this section are contained in numbered steps. In some of these steps you will need to make a note of a value for future reference and, to help with identification, the number of the step.

AC supply protection



Warning

The AC supply to the Drive must be fitted with suitable protection against overload and short-circuits. Table 2-1 shows recommended fuse ratings. Failure to observe this recommendation will cause a risk of fire.

STEP 1 Include a fuse of the specified rating in each phase of the AC supply. The use of the following types of fuse is recommended:

- Europe: Type gG HRC industrial fuses to IEC 269 (BS88)
- USA: RK1 600VAC

An MCB or MCCB having the correct thermal and magnetic trip ratings may be used in place of fuses, on condition the fault-current clearing capacity is sufficient for the installation.

Note

UL listing is dependent on the use of the correct type of UL-listed fuse, and applies when the symmetrical short-circuit current does not exceed 5kA for model sizes 1 to 3, and 10kA for model size 4. Refer to Appendix B *UL Listing Information*.

Table 2-1 Fuse ratings for Commander GP and LV

| Model | Fuse rating | Model | Fuse rating |
|----------------------|-------------|----------------------|-------------|
| GPD 1201 GPD 1401 | 6A | GPD 3201 GPD 3401 | 40A |
| GPD 1202 GPD 1402 | 10A | GPD 3402 | 50A |
| GPD 1203 GPD 1403 | 10A | GPD 3202 GPD 3403 | 60A |
| GPD 1204 GPD 1404 | 10A | GPD 3203 GPD 3404 | 70A |
| GPD 1205 GPD 1405 | 16A | GPD 3204 GPD 3405 | 80A |
| GPD 2201 GPD 2401 | 16A | GPD 4401 | 100A |
| GPD 2202 GPD 2402 | 20A | GPD 4402 | 125A |
| GPD 2203 GPD 2403 | 35A | GPD 4403 | 160A |
| | | GPD 4404 | 200A |
| | | GPD 4405 | 250A |

Power cables



Warning

Wiring must be in accordance with local regulations and codes of practice. The table below shows typical cable sizes for power input and output wiring. In the event of a conflict, local regulations prevail.

Cable type and size

STEP 2 For the following power connections...

- AC supply to RFI filter (when used)
- AC supply (or RFI filter) to Drive
- Drive to motor
- Drive to braking resistor

... use 105°C (221°F) pvc-insulated cable of suitable voltage rating and having copper conductors, as shown in Table 2-2.

Table 2–2 Cable sizes

| Model | Cable size | |
|----------------------|----------------------|---------------------|
| | GPD 1201 GPD 1401 | 1.5 mm ² |
| GPD 1202 GPD 1402 | 2.5 mm ² | 14 AWG |
| GPD 1203 GPD 1403 | 2.5 mm ² | 14 AWG |
| GPD 1204 GPD 1404 | 2.5 mm ² | 14 AWG |
| GPD 1205 GPD 1405 | 2.5 mm ² | 14 AWG |
| GPD 2201 GPD 2401 | 2.5 mm ² | 14 AWG |
| GPD 2202 GPD 2402 | 4 mm ² | 10 AWG |
| GPD 2203 GPD 2403 | 4 mm ² | 10 AWG |
| GPD 3201 GPD 3401 | 6 mm ² | 8 AWG |
| GPD 3402 | 10 mm ² | 6 AWG |
| GPD 3202 GPD 3403 | 10 mm ² | 6 AWG |
| GPD 3203 GPD 3404 | 16 mm ² | 4 AWG |
| GPD 3204 GPD 3405 | 25 mm ² | 4 AWG |
| GPD 4401 | 35 mm ² | 2 AWG |
| GPD 4402 | 35 mm ² | 2 AWG |
| GPD 4403 | 50 mm ² | 0 AWG |
| GPD 4404 | 70 mm ² | 2/0 AWG |
| GPD 4405 | 95 mm ² | 3/0 AWG |

When EMC emission requirements are to be met, shielded cable or steel wire armoured cable may be required for the following:

- AC supply to enclosure
- Drive to motor
- Drive to braking resistor when part of the cable is outside the enclosure

For further details, see *Wiring guidelines* later in this chapter.

Motor cable

STEP 3 Since capacitance in the motor cable causes loading on the output of the Drive, ensure the cable length does not exceed the values given in Table 2–3.

Table 2–3 Maximum cable lengths for Commander GP

| Nominal AC supply voltage | 400V | | 480V | |
|--|--|-----|------|-----|
| | Maximum cable length * (PWM switching frequency at 3kHz) | | | |
| Model | m | ft | m | ft |
| GPD 1201 GPD 1401 | 65 | 210 | 50 | 160 |
| GPD 1202 GPD 1402 | 100 | 330 | 75 | 250 |
| GPD 1203 GPD 1403 | 130 | 430 | 100 | 330 |
| GPD 1204 GPD 1404 | 200 | 660 | 150 | 490 |
| GPD 1205 GPD 1405 | 300 | 990 | 250 | 820 |
| GPD 2201 ~ GPD 2203 GPD 2401 ~ GPD 2403 | 300 | 990 | 300 | 990 |
| GPD 3201 ~ GPD 3204 GPD 3401 ~ GPD 3405 | 200 | 660 | 120 | 410 |
| GPD 4401 ~ GPD 4405 | 200 | 660 | 120 | 410 |

* Cable lengths in excess of the specified values may be used only when special techniques are adopted; refer to the supplier of the Drive.

The maximum cable length is reduced from that shown in the table under the following conditions:

- **PWM switching frequency exceeding 3kHz in model sizes 3 and 4**
The maximum cable length is reduced in proportion to the increase in PWM switching frequency, eg. at 9kHz, the maximum length is $\frac{1}{3}$ of that shown.
- **High-capacitance cables** Most cables have an insulating jacket between the cores and the armour or shield; these cables have a low capacitance and are recommended. Cables that do not have an insulating jacket tend to have high capacitance; if a cable of this type is used, the maximum cable length is half that quoted in the table. (Figure 2-1 shows how to identify the two types.)

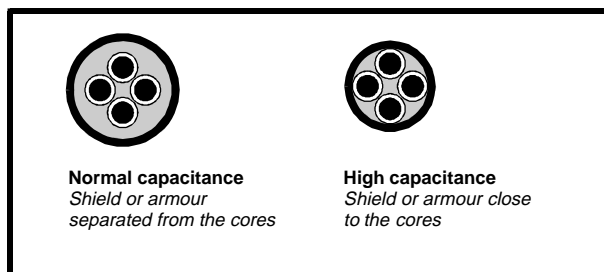

Figure 2-1 Cable construction influencing the capacitance

Multiple motors

Special requirements apply when the Drive is to control more than one motor. Refer to Appendix A *Motor Connections*.

Isolator switch in the motor cable

An isolator switch may be connected in the motor cable for safety purposes. Refer to the following Warning and Note.



Warning

The isolator switch must not be operated when the Drive is enabled. (If an AC-rated switch is used and the Drive is producing a low output frequency when the switch is opened, severe arcing can occur which will prevent the switch from breaking the circuit.)

A suitable interlock arrangement can be used, such as an isolator switch fitted with additional contacts that open before the main contacts. These additional contacts should be used to disable the Drive.

Note

If the isolator switch is closed when the Drive is enabled, the Drive may trip.

When EMC compliance is required, refer to *Variations in the EMC wiring recommendations* later in this chapter.

**Output current,
PWM switching frequency,
Ambient temperature**

Thermal protection

Note

The Drive can supply the rated current up to an ambient temperature of 40°C (104°F) (depending on the PWM switching frequency used).

The Drive can be operated in an ambient temperature up to 50°C (122°F) at de-rated output current. In this case, ensure the value of parameter 0.46 Motor rated current does not exceed the value given in Table 2-4.

The Drive has two forms of thermal protection for the power output stage (IGBT bridge), as follows:

1. A thermistor mounted on the heatsink monitors the heatsink temperature. If this exceeds 95°C (203°F), the thermistor will cause the Drive to trip. The display will indicate **Oh2**.
2. Intelligent thermal modelling estimates (by calculation) the junction temperature of the IGBTs. There are two temperature thresholds which cause the following to occur:
 - If the first threshold is reached, the PWM switching frequency is halved in order to reduce dissipation in the IGBTs. (When the frequency is halved, the value of parameter **0.41 PWM switching frequency** remains at the value set by the user; if the frequency is 3kHz or 4.5kHz, no halving occurs). Then at one second intervals, the Drive will attempt to restore the original PWM switching frequency. This will be successful if the estimated temperature has reduced sufficiently.
 - If the estimated temperature has continued to rise and reaches a second threshold, the Drive will trip. The display will indicate **Oh1**.

STEP 4 Note that the Drive can deliver an overload current up to 150% of the rated current for 60 seconds

Refer to Table 2–4 to find the maximum continuous output current that can be obtained for the required ambient temperature and PWM switching frequency. The maximum ambient temperature can be 40°C or 50°C (104°F or 122°F). Note that the nominal power rating of the Drive may not be achieved above 40°C (104°F).



Caution

Operation in a maximum ambient temperature of 50°C (122°F)

Unless the precaution described here is taken, the Drive will limit the maximum continuous output current only to the value for 40°C, (104°F) and not to the value stated in Table 2–4 for 50°C (122°F).

Make a note of the value for 50°C (122°F); you will need to refer to it when you reach *Configuring the Drive for the motor* in Chapter 2 of the *User Guide*.

At that point, ensure that the value to be entered in parameter **0.46 Motor – rated current does not exceed the noted value.**

Make a note of this step number and the following:

- Chosen maximum ambient temperature.
- Chosen **PWM switching frequency** for each Drive.
- From Table 2–5, the maximum **power dissipation** (heat) figure (P_{DISS}) at the chosen PWM switching frequency for each Drive (this figure is the total power dissipation at the maximum continuous output current available at the chosen PWM switching frequency, and includes power dissipated in option modules when fitted).
- If the maximum ambient temperature will be 50°C (122°F), note the value of the maximum permissible output current obtained from Table 2–4. This will be the maximum value that parameter **0.46 Motor – rated current** should be set at.

Table 2–4 Maximum permissible continuous output current

| 40°C (104°F) ambient | Nominal rating | | Maximum permissible continuous output current | | | | |
|-------------------------|--------------------|-------------------|--|--------|--------|--------|--------|
| | Model | 380V | 460V | 3kHz | 4.5kHz | 6kHz | 9kHz |
| GPD 1201 GPD 1401 | 0.37 kW 0.75 kW | 0.5 HP 1.0 HP | 2.1 A | 2.1 A | 2.1 A | 2.1 A | 2.1 A |
| GPD 1202 GPD 1402 | 0.55 kW 1.1 kW | 0.75 HP 1.5 HP | 2.8 A | 2.8 A | 2.8 A | 2.8 A | 2.8 A |
| GPD 1203 GPD 1403 | 0.75 kW 1.5 kW | 1.0 HP 2.0 HP | 3.8 A | 3.8 A | 3.8 A | 3.8 A | 3.8 A |
| GPD 1204 GPD 1404 | 1.1 kW 2.2 kW | 1.5 HP 3.0 HP | 5.6 A | 5.6 A | 5.6 A | 5.6 A | 4.5 A |
| GPD 1205 GPD 1405 | 2.2 kW 4.0 kW | 3.0 HP 5.0 HP | 9.5 A | 9.5 A | 8.5 A | 7.0 A | 5.5 A |
| GPD 2201 GPD 2401 | 3.0 kW 5.5 kW | 4.0 HP 7.5 HP | 12.0 A | 12.0 A | 12.0 A | 12.0 A | 11.7 A |
| GPD 2202 GPD 2402 | 4.0 kW 7.5 kW | 5.0 HP 10 HP | 16.0 A | 16.0 A | 16.0 A | 14.2 A | 11.7 A |
| GPD 2203 GPD 2403 | 5.5 kW 11.0 kW | 7.5 HP 15 HP | 25.0 A | 21.7 A | 18.2 A | 14.2 A | 11.7 A |
| GPD 3201 GPD 3401 | 7.5 kW 15.0 kW | 10 HP 20 HP | 34.0 A | 34.0 A | 34.0 A | 28.0 A | 23.0 A |
| GPD 3402 | 18.5 kW | 25 HP | 40.0 A | 40.0 A | 37.0 A | 28.0 A | 23.0 A |
| GPD 3202 GPD 3403 | 11.0 kW 22.0 kW | 15 HP 30 HP | 46.0 A | 46.0 A | 40.0 A | 32.0 A | 26.6 A |
| GPD 3203 GPD 3404 | 15.0 kW 30.0 kW | 20 HP 40 HP | 60.0 A | 47.0 A | 40.0 A | 32.0 A | 26.7 A |
| GPD 3204 GPD 3405 | 22.0 kW 37.0 kW | 30 HP 50 HP | 74.0 A 70.0 A | 56.0 A | 46.0 A | 35.0 A | 28.0 A |
| GPD 4401 | 45 kW | 75 HP | 96 A | 96 A | 88 A | 70 A | |
| GPD 4402 | 55 kW | 100 HP | 124 A | 104 A | 88 A | 70 A | |
| GPD 4403 | 75 kW | 125 HP | 156 A | 124 A | 105 A | 80 A | |
| GPD 4404 | 90 kW | 150 HP | 180 A | 175 A | 145 A | 110 A | |
| GPD 4405 | 110 kW | 150 HP | 202 A | 175 A | 145 A | 110 A | |

| 50°C (122°F) ambient | Nominal rating | | Maximum permissible continuous output current | | | | |
|-------------------------|--------------------|--------------------|---|--------|--------|--------|--------|
| | Model | 380V | 460V | 3kHz | 4.5kHz | 6kHz | 9kHz |
| GPD 1201 GPD 1401 | 0.37 kW 0.75 kW | 0.5 HP 1.0 HP | 2.1 A | 2.1 A | 2.1 A | 2.1 A | 2.1 A |
| GPD 1202 GPD 1402 | 0.55 kW 1.1 kW | 0.75 HP 1.5 HP | 2.8 A | 2.8 A | 2.8 A | 2.8 A | 2.8 A |
| GPD 1203 GPD 1403 | 0.75 kW 1.5 kW | 1.0 HP 2.0 HP | 3.8 A | 3.8 A | 3.8 A | 3.8 A | 3.3 A |
| GPD 1204 GPD 1404 | 1.1 kW 2.2 kW | 1.5 HP 3.0 HP | 5.6 A | 5.6 A | 5.1 A | 4.0 A | 3.3 A |
| GPD 1205 GPD 1405 | 2.2 kW 4.0 kW | 3.0 HP 5.0 HP | 6.9 A | 5.9 A | 5.1 A | 4.0 A | 3.3 A |
| GPD 2201 GPD 2401 | 3.0 kW 5.5 kW | 4.0 HP 7.5 HP | 12.0 A | 12.0 A | 12.0 A | 11.6 A | 9.7 A |
| GPD 2202 GPD 2402 | 4.0 kW 7.5 kW | 5.0 HP 10.0 HP | 16.0 A | 16.0 A | 14.7 A | 11.6 A | 9.7 A |
| GPD 2203 GPD 2403 | 5.5 kW 11.0 kW | 7.5 HP 15.0 HP | 20.0 A | 17.3 A | 14.7 A | 11.6 A | 9.7 A |
| GPD 3201 GPD 3401 | 7.5 kW 15.0 kW | 10.0 HP 20.0 HP | 34.0 A | 34.0 A | 28.0 A | 21.0 A | 17.9 A |
| GPD 3402 | 18.5 kW | 25.0 HP | 40.0 A | 34.0 A | 28.0 A | 21.0 A | 17.9 A |
| GPD 3202 GPD 3403 | 11.0 kW 22.0 kW | 15.0 HP 30.0 HP | 44.0 A | 36.0 A | 31.0 A | 24.0 A | 20.6 A |
| GPD 3203 GPD 3404 | 15.0 kW 30.0 kW | 20.0 HP 40.0 HP | 44.0 A | 36.0 A | 31.0 A | 24.0 A | 20.9 A |
| GPD 3204 GPD 3405 | 22.0 kW 37.0 kW | 30.0 HP 50.0 HP | 50.0 A | 41.0 A | 34.0 A | 26.0 A | 23.0 A |
| GPD 4401 | 45 kW | 75HP | 95 A | 85 A | 75 A | 60 A | |
| GPD 4402 | 55 kW | 100HP | 105 A | 85 A | 75 A | 60 A | |
| GPD 4403 | 75 kW | 125 HP | 135 A | 105 A | 85 A | 65 A | |
| GPD 4404 | 90 kW | 150 HP | 180 A | 150 A | 125 A | 95 A | |
| GPD 4405 | 110 kW | 150 HP | 190 A | 150 A | 125 A | 95 A | |

Table 2–5 Maximum total power dissipation

| Model | Nominal rating | | Maximum total power dissipation | | | | |
|----------------------|--------------------|-------------------|---------------------------------|--------|--------|--------|-------|
| | 380V | 460V | 3kHz | 4.5kHz | 6kHz | 9kHz | 12kHz |
| GPD 1201 GPD 1401 | 0.37 kW 0.75 kW | 0.5 HP 1.0 HP | 80 W | 80 W | 90 W | 90 W | 90 W |
| GPD 1202 GPD 1402 | 0.55 kW 1.1 kW | 0.75 HP 1.5 HP | 90 W | 90 W | 100 W | 100 W | 110 W |
| GPD 1203 GPD 1403 | 0.75 kW 1.5 kW | 1.0 HP 2.0 HP | 100 W | 110 W | 110 W | 120 W | 130 W |
| GPD 1204 GPD 1404 | 1.1 kW 2.2 kW | 1.5 HP 3.0 HP | 130 W | 130 W | 140 W | 150 W | 150 W |
| GPD 1205 GPD 1405 | 2.2 kW 4.0 kW | 3.0 HP 5.0 HP | 180 W | 190 W | 190 W | 190 W | 170 W |
| GPD 2201 GPD 2401 | 3.0 kW 5.5 kW | 4.0 HP 7.5 HP | 210 W | 230 W | 250 W | 280 W | 310 W |
| GPD 2202 GPD 2402 | 4.0 kW 7.5 kW | 5.0 HP 10 HP | 270 W | 290 W | 310 W | 320 W | 310 W |
| GPD 2203 GPD 2403 | 5.5 kW 11.0 kW | 7.5 HP 15 HP | 400 W | 380 W | 360 W | 330 W | 310 W |
| GPD 3201 GPD 3401 | 7.5 kW 15.0 kW | 10 HP 20 HP | 570 W | 620 W | 670 W | 660 W | 630 W |
| GPD 3402 | 18.5 kW | 25 HP | 660 W | 720 W | 730 W | 660 W | 630 W |
| GPD 3202 GPD 3403 | 11 kW 22.0 kW | 15 HP 30 HP | 730 W | 800 W | 770 W | 730 W | 700 W |
| GPD 3203 GPD 3404 | 15 kW 30.0 kW | 20 HP 40 HP | 950 W | 830 W | 790 W | 740 W | 710 W |
| GPD 3204 GPD 3405 | 22 kW 37.0 kW | 30 HP 50 HP | 1090 W | 990 W | 920 W | 850 W | 800 W |
| GPD 4401 | 45kW | 75 HP | 1460 W | 1610 W | 1630 W | 1530 W | |
| GPD 4402 | 55 kW | 100 HP | 1910 W | 1780 W | 1670 W | 1560 W | |
| GPD 4403 | 75 kW | 125 HP | 2370 W | 2130 W | 2030 W | 1860 W | |
| GPD 4404 | 90 kW | 150 HP | 2640 W | 2890 W | 2700 W | 2470 W | |
| GPD 4405 | 110 kW | 150 HP | 2970 W | 2910 W | 2720 W | 2490 W | |

The default PWM switching frequency is 3kHz

Using an RFI filter

STEP 5 For compliance with the emission standards such as EN 50081-1 or EN 50081-2, use the recommended RFI filter as shown in Table 2–6. Use one RFI filter for each Drive. (Standards that are met are specified in Appendix C *Data*)

Make a note of this step number and the following for each filter to be used:

- Size code or part number
- Maximum power dissipation figure
- IP rating

Table 2–6 RFI filter data

| Model | RFI filter | | | |
|----------------------|------------|-------------|-------------------------------|-----------|
| | Size | Part number | Maximum power dissipation (W) | IP rating |
| GPD 1201 GPD 1401 | A | 4200–0010 | 25 | IP20 |
| GPD 1202 GPD1402 | A | 4200–0010 | 25 | IP20 |
| GPD 1203 GPD 1403 | A | 4200–0010 | 25 | IP20 |
| GPD 1204 GPD 1404 | A | 4200–0010 | 25 | IP20 |
| GPD 1205 GPD 1405 | A | 4200–0010 | 25 | IP20 |
| GPD 2201 GPD 2401 | B | 4200–0027 | 40 | IP20 |
| GPD 2202 GPD 2402 | B | 4200–0027 | 40 | IP20 |
| GPD 2203 GPD 2403 | B | 4200–0027 | 40 | IP20 |
| GPD 3201 GPD 3401 | C | 4200–1051 | 60 | IP00 |
| GPD 3402 | C | 4200–1051 | 60 | IP00 |
| GPD 3202 GPD 3403 | C | 4200–1051 | 60 | IP00 |
| GPD 3203 GPD 3404 | D | 4200–1071 | 100 | IP00 |
| GPD 3204 GPD 3405 | D | 4200–1071 | 100 | IP00 |
| GPD 4401 | E | 4200–1111 | 120 | IP00 |
| GPD 4402 | F | 4200–1172 | 150 | IP00 |
| GPD 4403 | F | 4200–1172 | 150 | IP00 |
| GPD 4404 | F | 4200–1172 | 150 | IP00 |
| GPD 4405 | H | 4200–1220 | 200 | IP00 |

Model size 1

When the motor cable is to exceed 50m (165 feet), use RFI filter size *B* (4200–0027).

Using a braking resistor

Note

When a braking resistor is used the Drive should be operated in FAST ramp mode. The Drive will not follow the deceleration ramp set if this mode is not used.

Braking occurs when the Drive is decelerating the motor, or is preventing the motor from gaining speed due to mechanical influences. During braking, energy is returned to the Drive by the motor.

When the motor is being braked by the Drive, the maximum regenerated power that the Drive can absorb is equal to the power dissipation (losses) of the Drive.

When the regenerated power is likely to exceed these losses, a braking resistor must be connected.

By default, the Drive brakes the motor under PI control which extends the deceleration time as necessary in order to keep the DC bus at a constant voltage. The method of braking can be changed; if required.

Housing the resistor, and routing the connecting cable



Warning

High temperatures

Braking resistors can reach high temperatures. Locate braking resistors so that damage cannot result.

Use cable having insulation capable of withstanding high temperatures.



Warning

Overload protection

It is essential that an overload protection device is incorporated in the braking resistor circuit; this is described in *Protection circuit for an optional braking resistor* in STEP 8.

STEP 6 When a braking resistor is to be mounted outside the enclosure, ensure that it is mounted in a ventilated metal housing that will perform the following functions:

- Prevent inadvertent contact with the resistor
- Allow adequate ventilation for the resistor

When compliance with EMC emission standards is required, external connection requires the cable to be armoured or shielded, since it is not fully contained in a metal enclosure.

Internal connection does not require the cable to be armoured or shielded.

Minimum resistances and power ratings

Table 2-7 Minimum resistance values and peak power rating for the braking resistor at 40°C (104°F)

| Model | Minimum resistance | Instantaneous power rating |
|--|--------------------|----------------------------|
| GPD 1201 - GPD 1205 GPD 1401 ~ GPD 1405 | 20 Ω 40Ω | 15kW |
| GPD 2201 GPD 2401 | 20 Ω 40Ω | 15kW |
| GPD 2202, GPD 2203 GPD 2402, GPD 2403 | 15 Ω 30Ω | 20kW |
| GPD 3201 - GPD 3204 GPD 3401 ~ GPD 3405 | 5 Ω 10Ω | 60kW |
| GPD 4401 ~ GPD 4405 | 5Ω | 120kW |

The minimum resistance allows the braking resistor to dissipate up to approximately 150% of the power rating of the Drive for up to 60 seconds.

For high-inertia loads or under continuous braking, the *continuous power* dissipated in the braking resistor may be as high as the power rating of the Drive. The total *energy* dissipated in the braking resistor is dependent on the amount of energy to be extracted from the load.

The instantaneous power rating refers to the short-term maximum power dissipated during the *on* intervals of the pulse width modulated braking control cycle. The braking resistor must be able to withstand this dissipation for short intervals (milliseconds). Higher resistance values require proportionately lower instantaneous power ratings.

In most applications, braking occurs only occasionally. This allows the continuous power rating of the braking resistor to be much lower than the power rating of the Drive. It is essential, though, that the instantaneous power rating and energy rating of the braking resistor are sufficient for the most extreme braking duty that is likely to be encountered.

STEP 7 Select a value of resistance for the braking resistor that is not less than the specified minimum resistance. Larger resistance values may give a cost saving, as well as a safety benefit in the event of a fault in the braking system. Braking capability will then be reduced, which may cause the Drive to trip during braking. If this occurs, refer to *Deceleration rate* in Chapter 2 of the *User Guide*.

STEP 8 Estimate the average power that will be dissipated in the resistor. Make a note of this step number and the average power to be dissipated in the resistor.

Thermal protection circuit for the braking resistor

The thermal protection circuit must disconnect the AC supply from the Drive if the resistor becomes overloaded. Figure 2-2 shows a typical circuit arrangement.

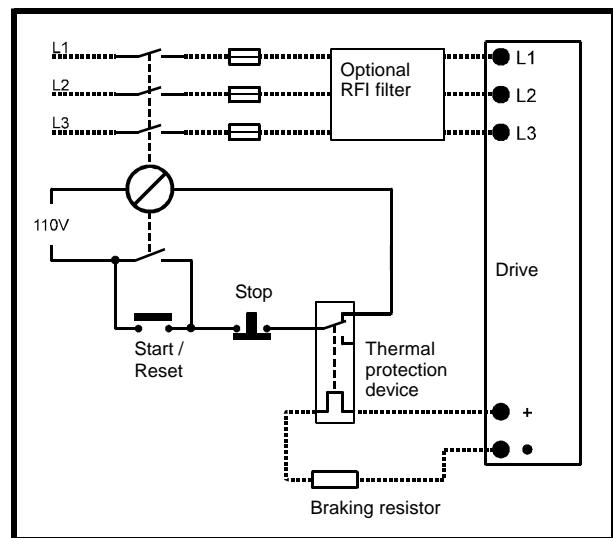

Figure 2-2 Typical protection circuit for a braking resistor

Enclosure layout

STEP 9 Use one of the following enclosure layouts, depending on the requirements of the installation:

Routine EMC precautions Refer to Figure 2–3 which shows the recommended layout for two Drives, and the signal and power cables.

Compliance with EMC emission standards Refer to Figure 2–4 which shows the recommended layout for two Drives, two RFI filters, and the signal and power cables.

STEP 10 Decide whether the enclosure is to be sealed or ventilated, as follows:

A sealed enclosure can give a high ingress-protection rating, but with reduced heat removal capabilities. If possible, locate heat-generating equipment (other than braking resistors) in the lower part of the enclosure to encourage internal convection. If necessary, a taller enclosure, and/or air-circulation fans inside the enclosure, can be used. For calculating the minimum size of sealed enclosure that will adequately cool the Drive(s), refer later in this chapter to *Calculating the size of a sealed enclosure*.

If a high ingress-protection rating is not required, a ventilated enclosure can be used with a fan to supply forced air cooling; this can give a lower ambient temperature than a sealed enclosure. For calculating the minimum required volume of cooling air, refer later in this chapter to *Calculating the air-flow in a ventilated enclosure*.

STEP 11 For compliance with EMC emission standards, ensure the enclosure is fitted with an unpainted metal back-plate for mounting the Drive and RFI filter. For example, a zinc plated steel back-plate is suitable (see Figure 2–4).

STEP 12 Ensure the Drive is installed vertically for best flow of cooling air through the Drive and heatsink.

STEP 13 Ensure the clearances around the Drive are as follows:

Above and below: $\geq 100\text{mm}$ (4 in)

Both sides: $\geq 5\text{mm}$ ($\frac{1}{4}$ in)

Note

When surface mounting a model size 3, allow a clearance of 150mm (6in) above the Drive; this is required for dismantling. A minimum clearance of 100mm (4in) is required for ventilation.

For overall dimensions and weights of the Drive and RFI filter, see Appendix C *Data*.

STEP 14 When compliance with EMC emission standards is required, the RFI filter must be installed at the specified position for each Drive (see Figure 2–4).

STEP 15 When a braking resistor is to be used, it can be installed outside or inside the enclosure. When installed inside, it must be mounted in the upper part of the enclosure to prevent it heating the other equipment by convection.

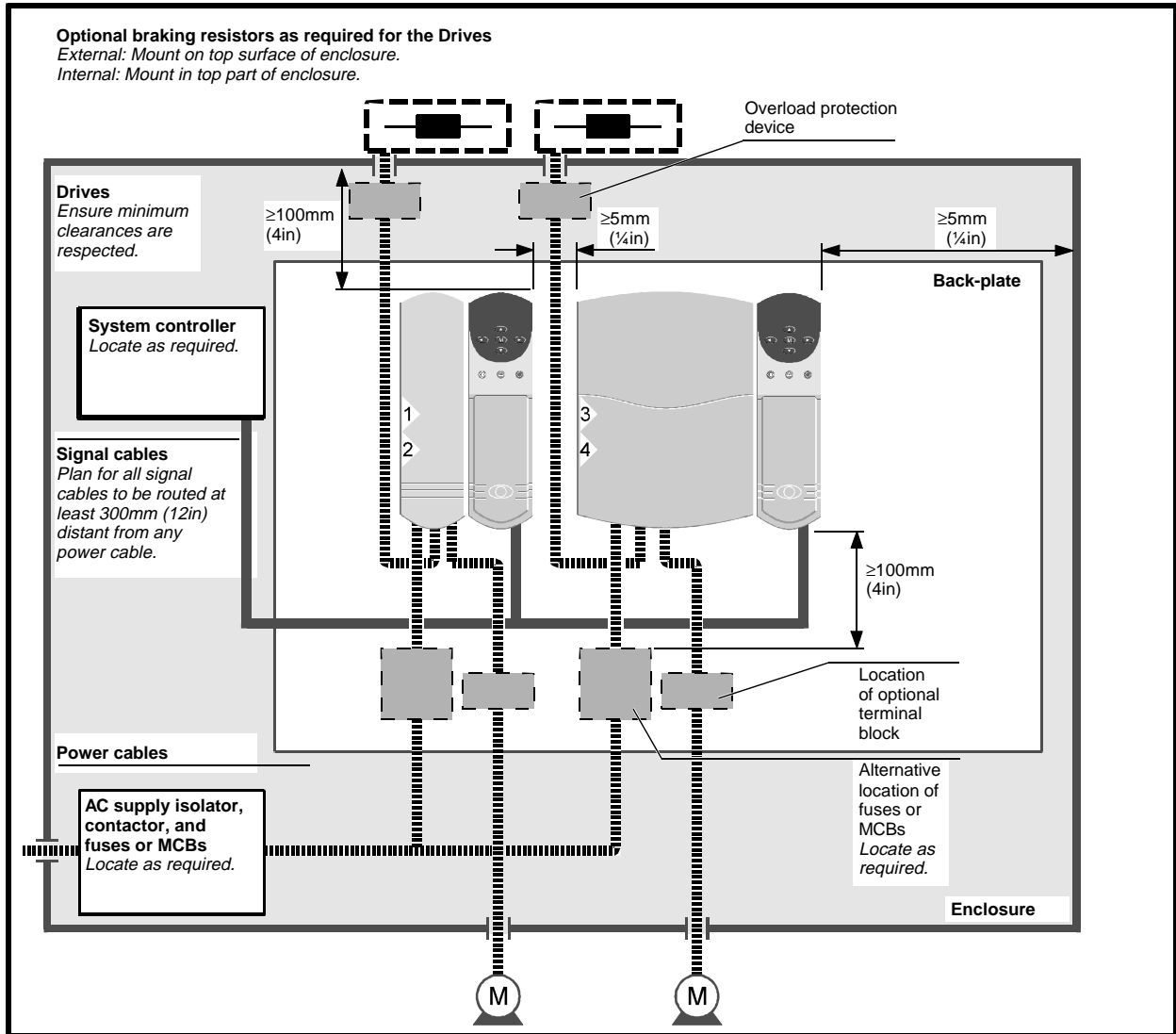

Figure 2-3 Recommended layout for routine EMC precautions (wiring recommendations are given in Figure 2-21)

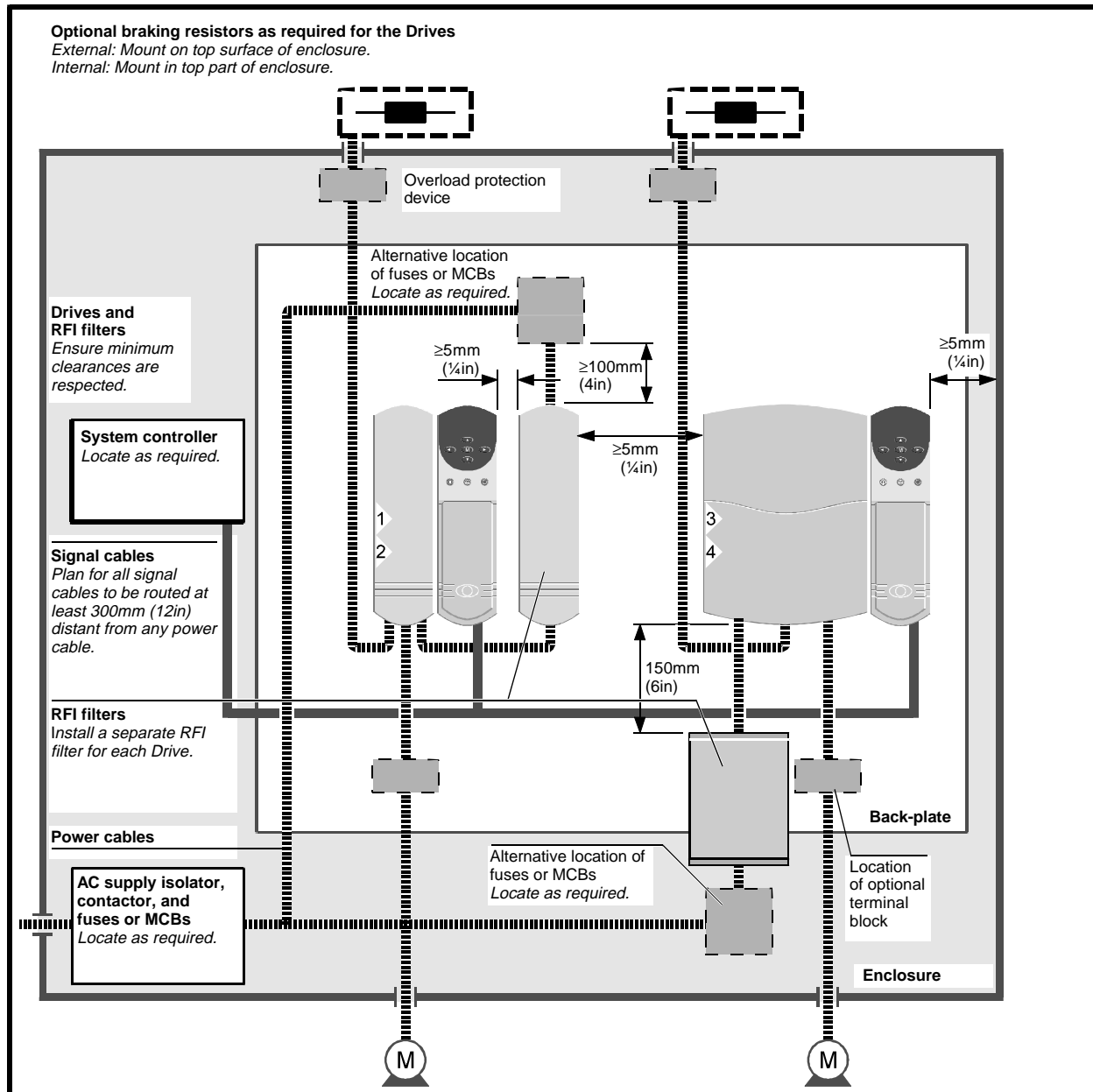

Figure 2-4 Recommended layout for compliance with EMC emission standards (wiring recommendations are given in Figures 2-22 and 2-23)

2.4 Calculating the enclosure size

- STEP 1** Add the dissipation figures from step 4 of *Planning the installation* for each Drive that is to be installed in the enclosure. Make a note of this step number and the total value.
- STEP 2** If an RFI filter is to be used with each Drive, add the dissipation figures from step 5 of *Planning the installation* for each RFI filter that is to be installed in the enclosure. Make a note of this step number and the total value.
- STEP 3** If the braking resistor is to be mounted inside the enclosure, add the average power figures from step 8 of *Planning the installation* for each braking resistor that is to be installed in the enclosure. Make a note of this step number and the total value.
- STEP 4** Make a note of this step number and the total heat dissipation (in Watts) of any other equipment to be installed in the enclosure.
- STEP 5** Add the heat dissipation figures obtained (as appropriate) from steps 1, 2, 3 and 4 above. This gives a figure in Watts for the total heat that will be dissipated inside the enclosure. Make a note of this figure and the step number.

Calculating the size of a sealed enclosure

The enclosure transfers internally generated heat into the surrounding air by natural convection (or external forced air flow); the greater the surface area of the enclosure walls, the better is the dissipation capability. Only the surfaces of the enclosure that are unobstructed (not in contact with a wall or floor) can dissipate heat.

Calculate the minimum required unobstructed surface area A_e for the enclosure from:

$$A_e = \frac{P}{k(T_{int} - T_{ext})}$$

Where:

- A_e Unobstructed surface area in m^2 ($1m^2 = 10.8 ft^2$)
- T_{ext} Maximum expected ambient temperature in $^{\circ}C$ *outside* the enclosure
- T_{int} Maximum permissible ambient temperature in $^{\circ}C$ *inside* the enclosure
- P Power in Watts dissipated by *all* heat sources in the enclosure
- k Heat transmission coefficient of the enclosure material in $W/m^2/^{\circ}C$

Example

To calculate the size of an enclosure for the following:

- Two GPD 1405 models
- Each Drive to operate at 4.5kHz PWM switching frequency
- RFI filter for each Drive
- Braking resistors are to be mounted outside the enclosure
- Maximum ambient temperature inside the enclosure: $40^{\circ}C$
- Maximum ambient temperature outside the enclosure: $30^{\circ}C$

Dissipation of each Drive: 190W (from step 4 in *Planning the installation*)

Dissipation of each RFI filter: 25W (max) (from step 5 in *Planning the installation*)

Total dissipation: $2 \times (190 + 25) = 430W$

The enclosure is to be made from painted 2mm ($3/32$ in) sheet steel having a heat transmission coefficient of $5.5W/m^2/^{\circ}C$. Only the top, front, and two sides of the enclosure are to be free to dissipate heat.

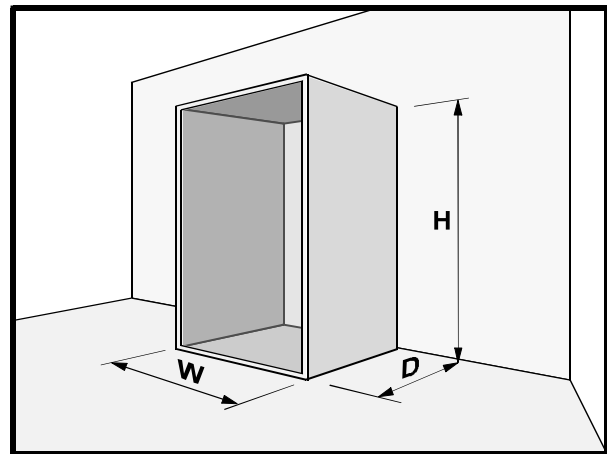

Figure 2-5 Enclosure having front, sides and top panels free to dissipate heat

Insert the following values:

- T_{int} $40^{\circ}C$
- T_{ext} $30^{\circ}C$
- k 5.5
- P $430W$

The minimum required heat conducting area is then:

$$A_e = \frac{430}{5.5(40 - 30)} = 7.8m^2 (85ft^2)$$

($1m = 3.3 ft$)

Estimate two of the enclosure dimensions — the height (H) and depth (D), for instance. Calculate the width (W) from:

$$W = \frac{A_e - 2HD}{H + D}$$

Inserting **H** = 2m and **D** = 0.6m, obtain the minimum width:

$$W = \frac{7.8 - (2 \times 2 \times 0.6)}{2 + 0.6} = 2.1\text{m (6ft 10in)}$$

If the enclosure is too large for the space available, it can be made smaller only by attending to one or all of the following:

- Using a lower PWM switching frequency to reduce the dissipation in the Drives (return to step 4 in *Planning the installation*)
- Reducing the ambient temperature outside the enclosure, and/or applying forced-air cooling to the outside of the enclosure
- Reducing the number of Drives in the enclosure
- Removing other heat-generating equipment

Calculating the air-flow in a ventilated enclosure

The dimensions of the enclosure are required only for accommodating the equipment. The equipment is cooled by the forced air flow.

Calculate the minimum required volume of ventilating air from:

$$V = \frac{3kP}{T_{\text{int}} - T_{\text{ext}}}$$

Where:

- V** Air-flow in m³ per hour
- T_{ext}** Maximum ambient temperature in °C outside the enclosure
- T_{int}** Maximum ambient temperature in °C inside the enclosure
- P** Power in Watts dissipated by *all* heat sources in the enclosure
- k** Ratio of $\frac{P_0}{P_1}$

Where:

- P₀** is the air pressure at sea level
- P₁** is the air pressure at the installation

Typically use a factor of 1.2 to 1.3, to allow also for pressure-drops in dirty air-filters.

Example

To calculate the size of an enclosure for the following:

- Three GPD 3401 models
- Each Drive to operate at 6kHz PWM switching frequency
- RFI filter for each Drive
- Braking resistors are to be mounted outside the enclosure
- Maximum ambient temperature inside the enclosure: 40°C
- Maximum ambient temperature outside the enclosure: 30°C

Dissipation of each Drive: 670W (from step 4 in *Planning the installation*)

Dissipation of each RFI filter: 60W (max) (from step 5 in *Planning the installation*)

Total dissipation: 3 x (670 + 60) = 2190W

Insert the following values:

| | |
|------------------------|-------|
| T_{int} | 40°C |
| T_{ext} | 30°C |
| k | 1.3 |
| P | 2190W |

Then:

$$V = \frac{3 \times 1.3 \times 2190}{40 - 30} = 854\text{m}^3 / \text{hr (504 ft}^3 / \text{min)}$$

(1m³/hr = 0.59ft³/min)

2.5 Installing the Drive and RFI filter



Warning

Lifting the Drive

The weights of model sizes 3 and 4 are 22kg (49 lbs) and 70kg (154 lbs) respectively. Use appropriate safeguards when lifting these models.

Removing the terminal covers

The Drive is fitted with one or two terminal covers depending on the model size. When model sizes 1, 3 and 4 are through-panel mounted, the terminal cover(s) must first be removed in order for access to be gained to the lower mounting holes.

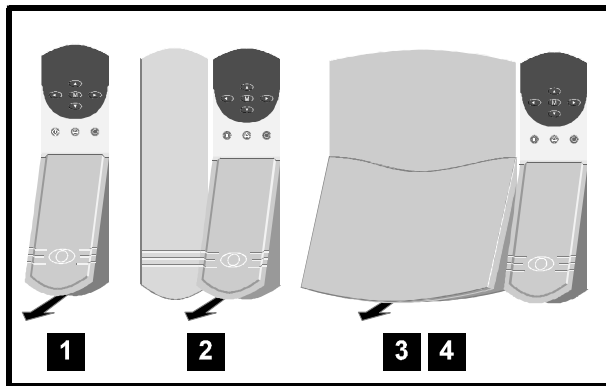

Figure 2-6 Removing the terminal covers

The terminal cover(s) of all models must be removed for access to the electrical connectors.

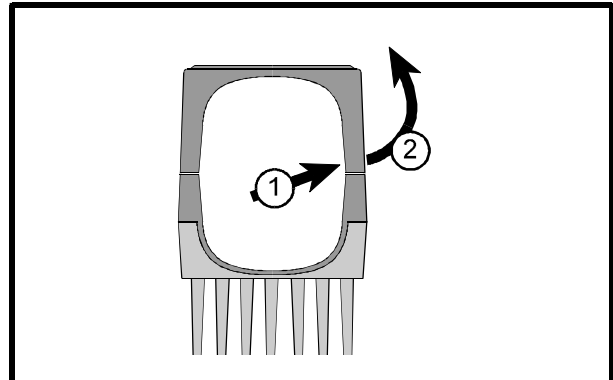

Figure 2-7 View from the underside showing how a terminal cover is removed from the Drive

Remove terminal covers, as follows:

1. Working on either side of the terminal cover, push the inner edge of the cover firmly outward until it becomes unclipped.
2. Swing the side of the cover outward and upward until the remaining clips become released.
3. Remove the gland plate (you may need to replace it later).

Mounting brackets supplied with the Drive

Table 2–8 General views of the mounting brackets

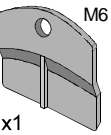
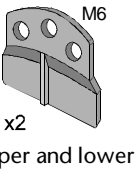
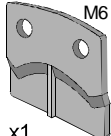
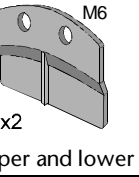
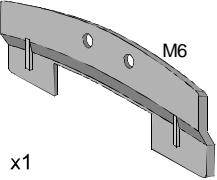
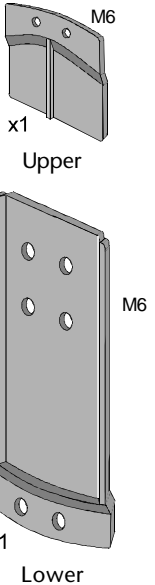
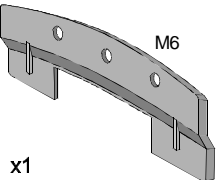
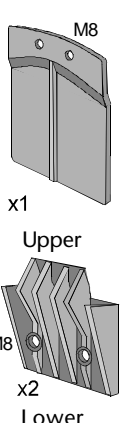
| Model size | Through-panel | Surface |
|------------|---|---|
| 1 |  |  |
| 2 |  |  |
| 3 |  |  |
| 4 |  |  |

Rear view of the brackets (except for the lower bracket for model size 4). The brackets are not shown to scale.

Surface-mounting the Drive

1. Use the two surface-mounting brackets. These are manufactured from metal. Ensure the brackets make direct electrical contact with the back-plate; for example, tap M6 ($\frac{1}{4}$ in) threaded holes in the back-plate in the positions shown in Figure 2–10 to accept the mounting screws. (For model size 1, you may use the central or, preferably, the two outer screw holes in the mounting bracket.)
2. Insert the surface mounting brackets into the slots in the top and bottom of the Drive heatsink, as shown in Figure 2–8.

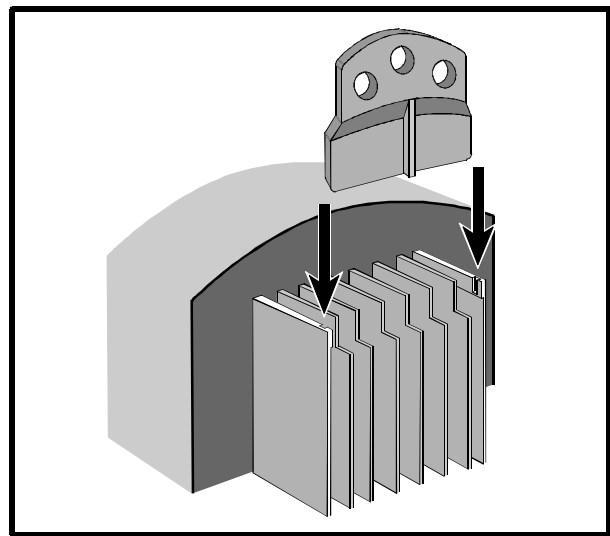

Figure 2–8 General representation showing the fitting of a surface mounting bracket in a heatsink

3. Retain the mounting brackets to the back-plate using electrically conducting screws.

Note

When surface mounting a model size 3, allow a clearance of 150mm (6in) above the Drive; this is required for dismounting. A minimum clearance of 100mm (4in) is required for ventilation.

This page is intentionally not used

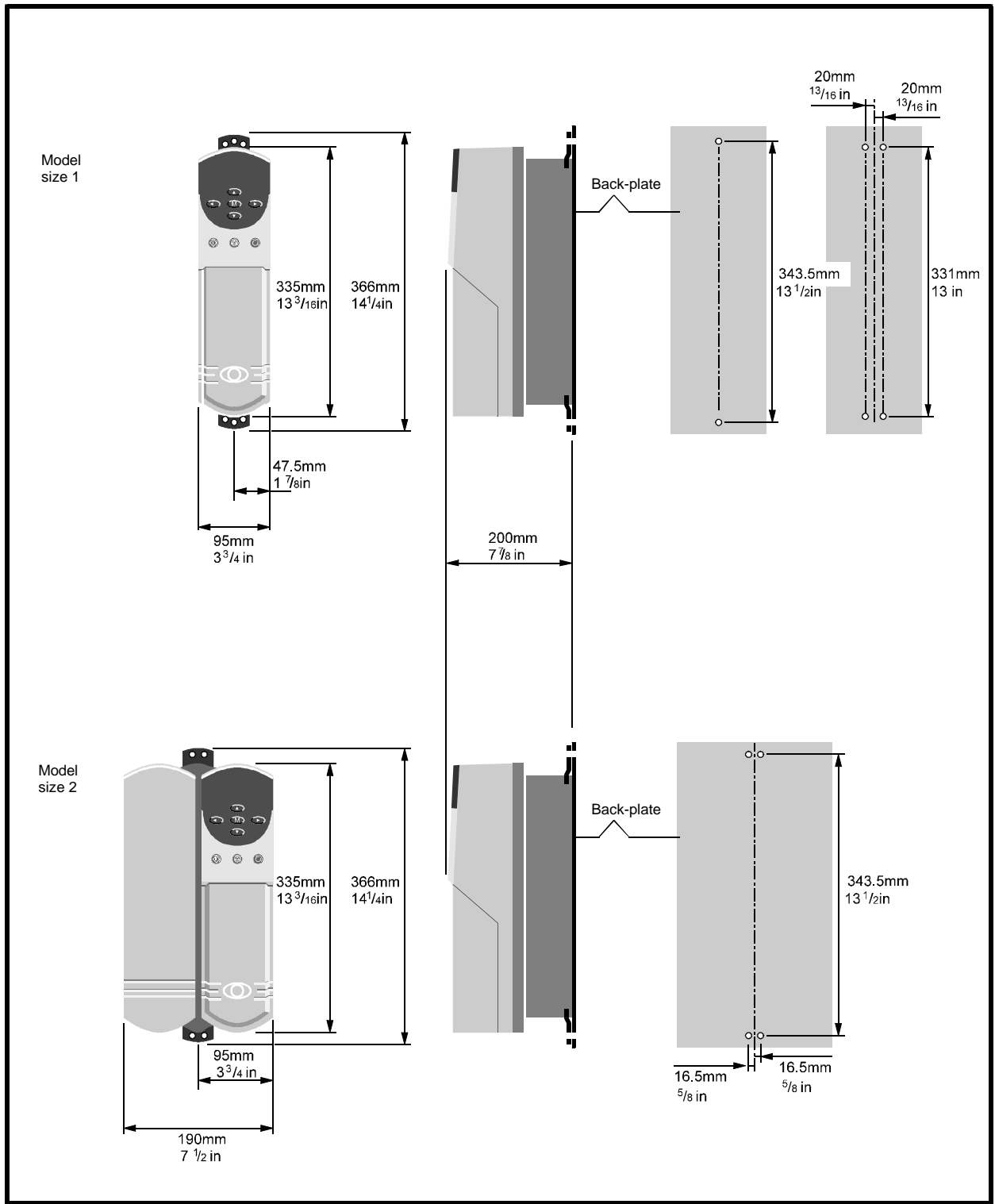

Figure 2-9 Surface mounting of model sizes 1 and 2

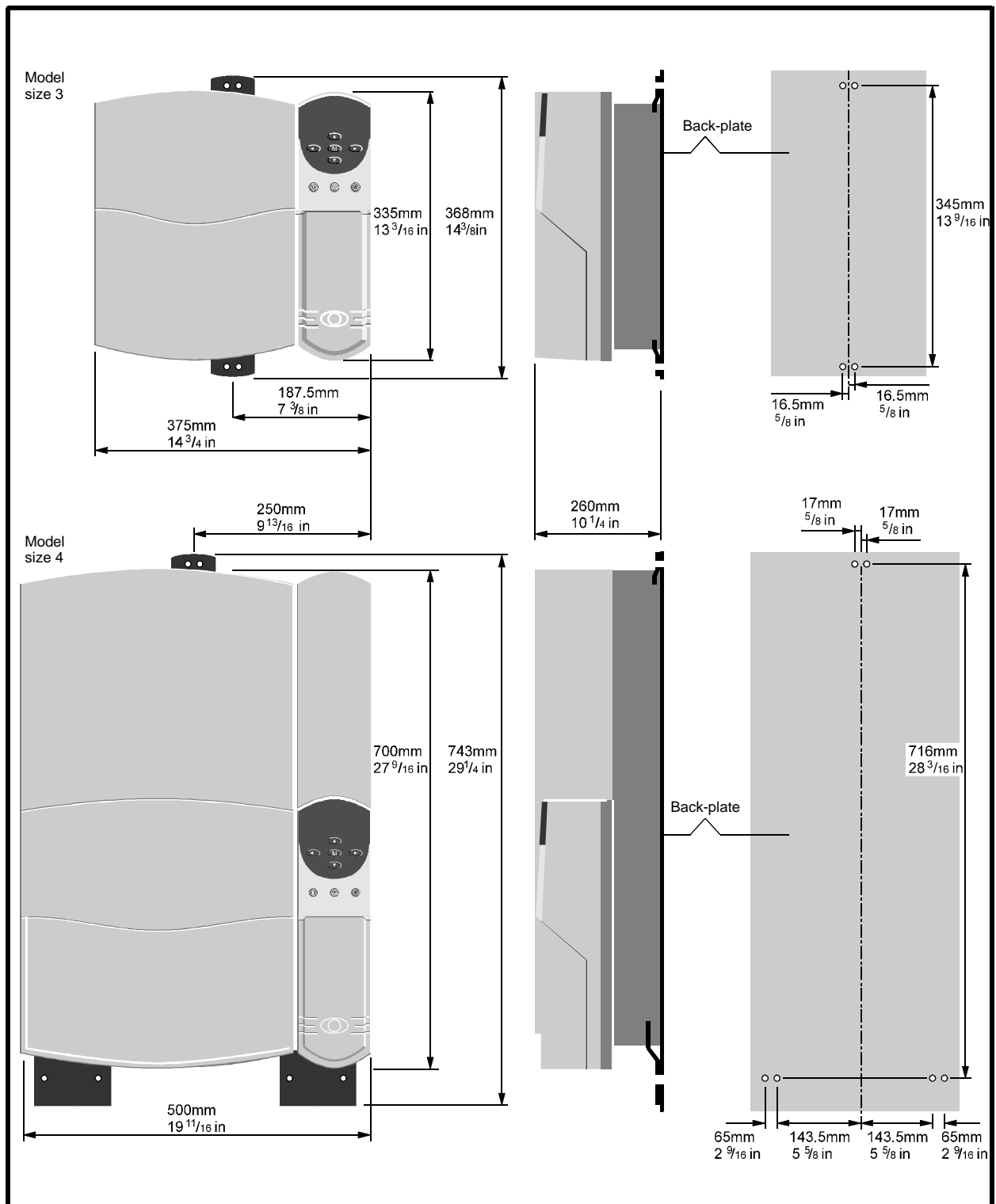

Figure 2–10 Surface mounting of model sizes 3 and 4

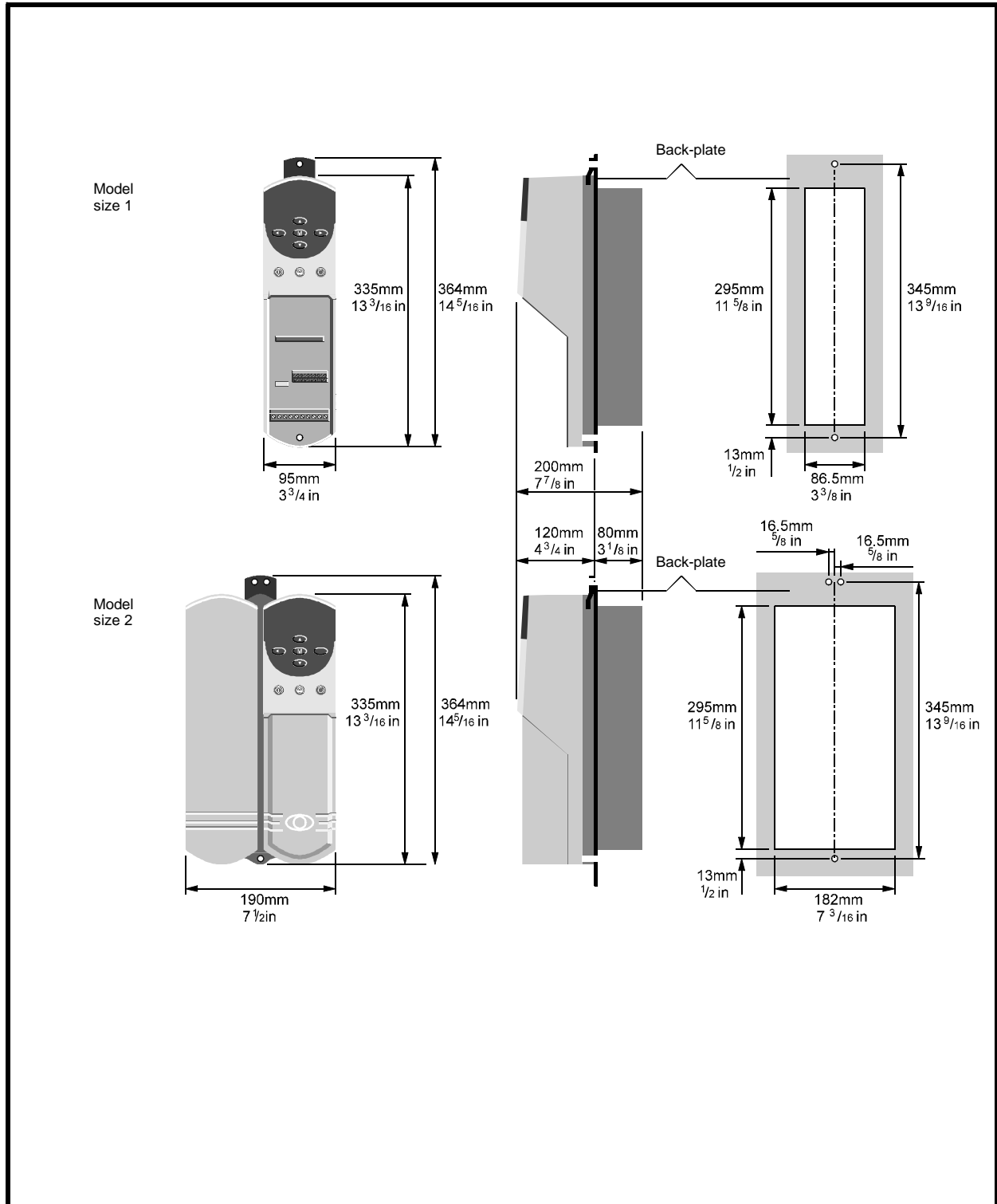

Figure 2–11 Through-panel mounting of model sizes 1 and 2

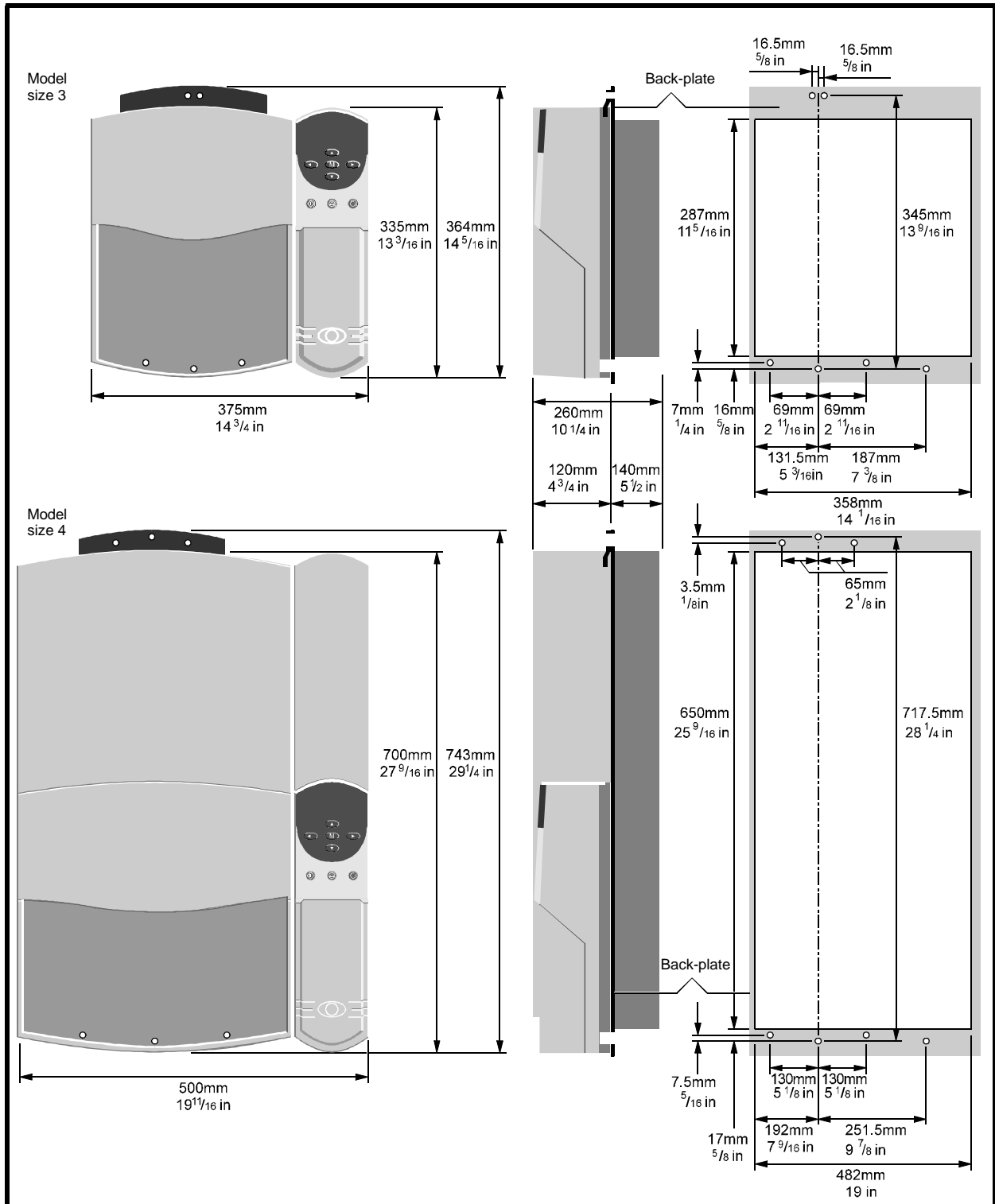

Figure 2-12 Through-panel mounting of model sizes 3 and 4

Through-panel mounting the Drive

1. Cut an aperture in the back-plate as shown in Figure 2–11 or 2–12 as appropriate.
2. Use the through-panel mounting bracket. This is manufactured from metal and is used to secure the top of the Drive to the back-plate; the bottom of the Drive is secured to the back-plate by screw(s) passed through a hole in the casing and heatsink.
Ensure the bracket and heatsink make direct electrical contact with the back-plate; for example, tap M6 (1/4 in) threaded holes in the back-plate in the positions shown in Figure 2–11 or 2–12 to accept the mounting screws.
3. Insert the through-panel mounting bracket into the recess in the top of the Drive heatsink, as shown in Figure 2–13.

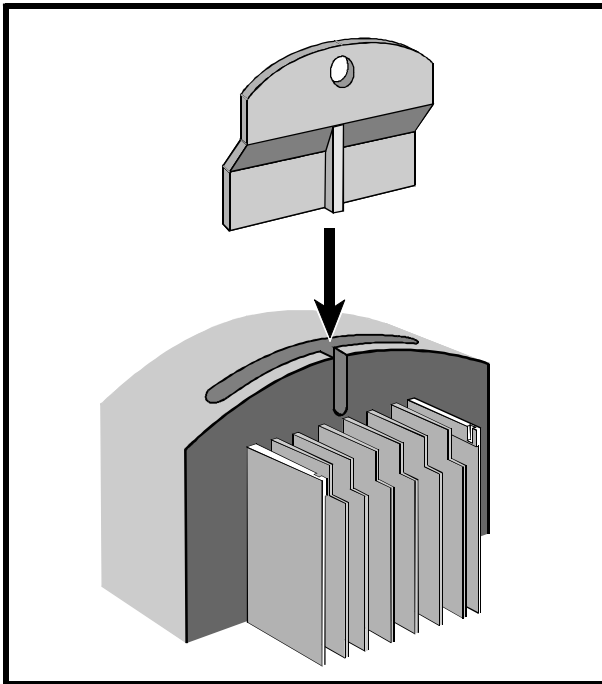

Figure 2–13 General representation showing the fitting of a through-panel mounting bracket in the top of the Drive

4. If a seal is required between the Drive and the back-plate, attach the foam sealing strip (supplied with the Drive) around the edges of the aperture in the back-plate so that the flange on the heatsink will press against the foam strip.
5. Insert the Drive into the aperture.
6. Secure the bottom of the Drive to the panel using electrically conducting screw(s).
7. Secure the through-panel mounting bracket to the panel using electrically conducting screw(s).



Caution

When the Drive is through-panel mounted, a baffle plate must be fitted at the rear of the heatsink.

Fitting a baffle plate



Warning

If the Drive has been used, the heatsink may be hot. Human contact with the heatsink should be restricted.

When the Drive is through-panel mounted, the fitting of a baffle plate causes the heatsink to act as a chimney; this enhances the air flow along the heatsink fins to aid cooling (this naturally occurs when the Drive is surface mounted).

You may make a baffle plate from any suitable conducting or non-conducting material and attach it to the heatsink by the method described overleaf.

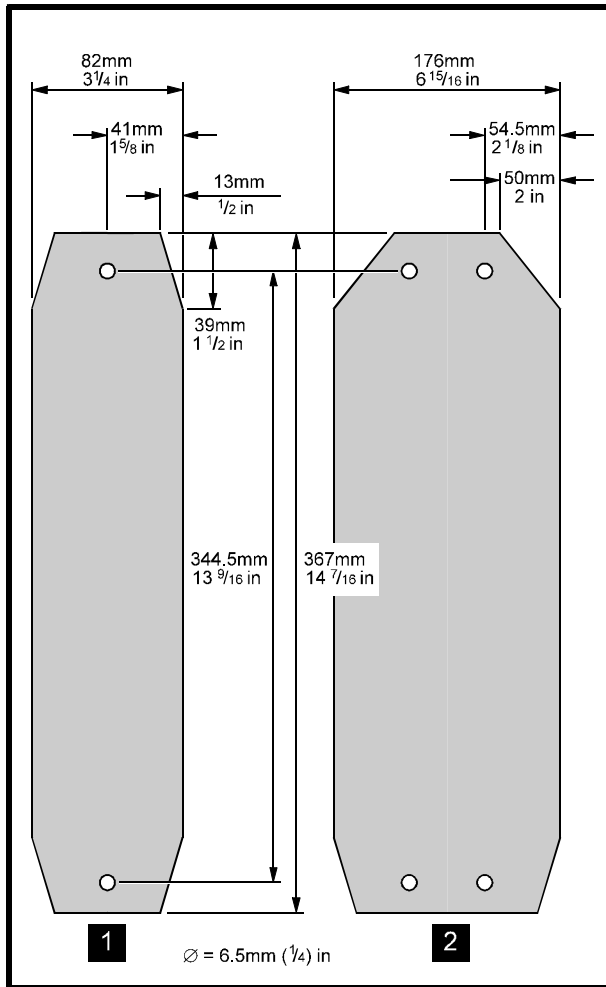

Figure 2-14 Dimensions for the fabrication of baffle plates for model sizes 1 and 2

Attaching a fabricated baffle plate to the heatsink

Table 2-10 Methods of attaching the baffle plate

| Model size | Method of attachment |
|------------|--|
| 1 2 | Use the surface mounting brackets. |
| 3 4 | Use M6 x 12mm max (or equivalent) thread-forming screws to screw into the holes in the heatsink, or tap the holes to a suitable thread size. |

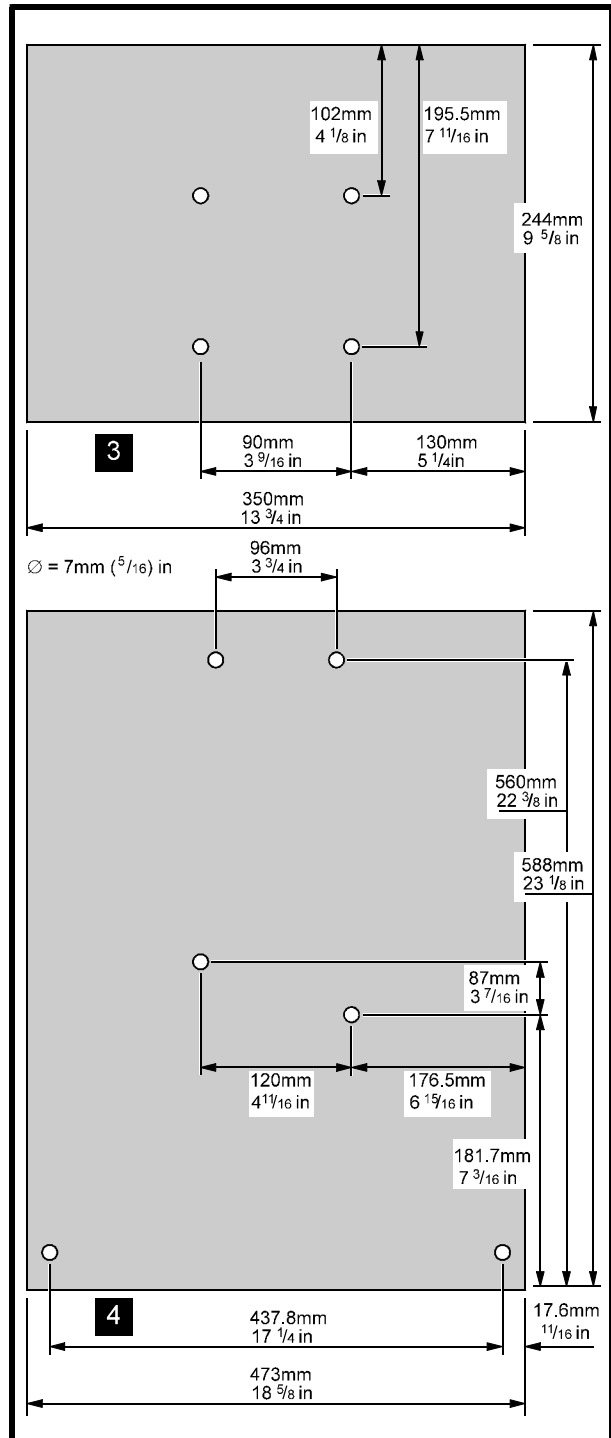

Figure 2-15 Dimensions for the fabrication of baffle plates for model sizes 3 and 4

This page is intentionally not used

Mounting the RFI filter

The RFI filters can be surface-mounted only.

Mount the RFI filter at the specified location in relation to the Drive. In the case of filter sizes C to G, ensure the LOAD terminals face the Drive.

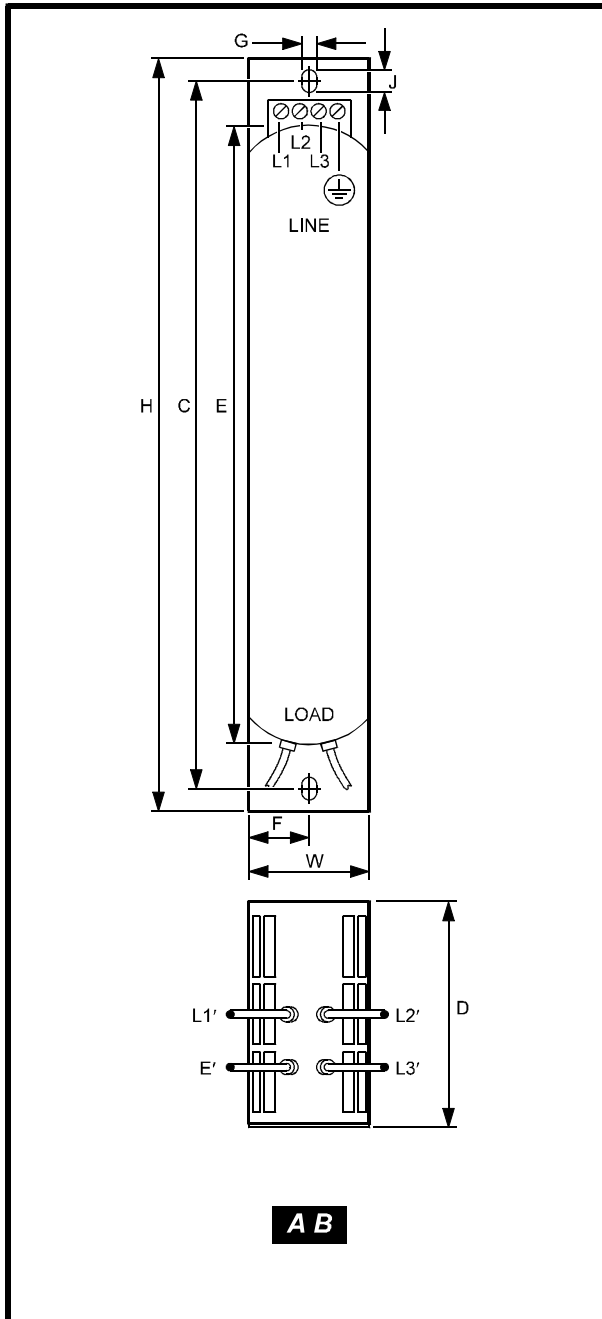

| Dimension | RFI filter size | |
|-----------|---|---|
| | A 4200-0010 | B 4200-0027 |
| C | 378mm 14 ⁷ / ₈ in | 388mm 15 ¹ / ₄ in |
| D | 114.5mm 4 ¹ / ₂ in | 114.5mm 4 ¹ / ₂ in |
| E | 335mm 13 ³ / ₁₆ in | 335mm 13 ³ / ₁₆ in |
| F | 25mm 1 in | 37.5mm 1 ¹ / ₂ in |
| G | 6.4mm ¹ / ₄ in | 6.4mm ¹ / ₄ in |
| H | 396mm 15 ⁹ / ₁₆ in | 406mm 16 in |
| J | 10mm ³ / ₈ in | 10mm ³ / ₈ in |
| W | 50mm 1 ¹⁵ / ₁₆ in | 75mm 2 ¹⁵ / ₁₆ in |

Figure 2-16 Principal dimensions of RFI filters sizes A and B, and the locations of the terminals

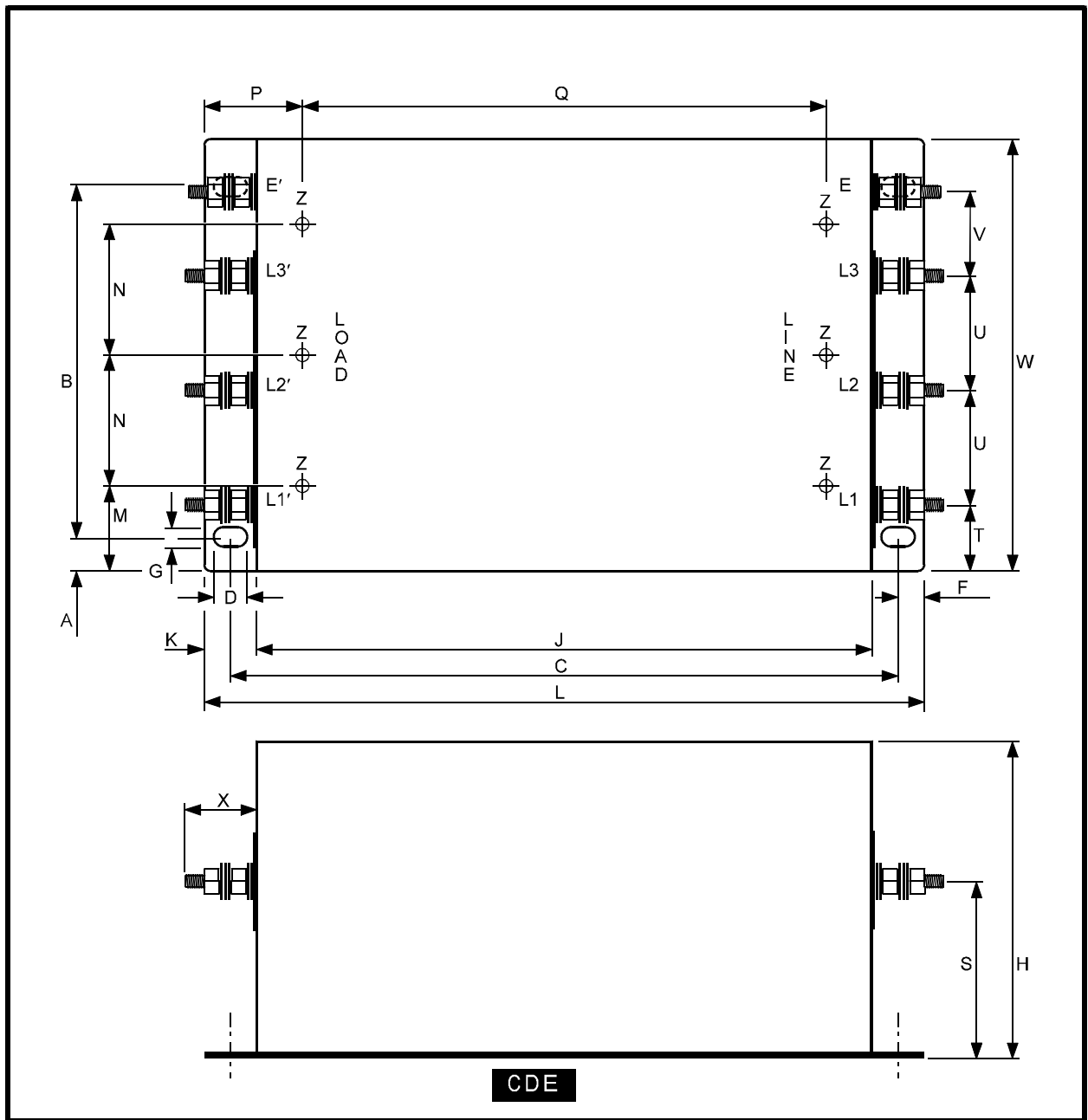

Figure 2-17 Principal dimensions of RFI filters sizes C to E, and the locations of the terminals

| Dimension | RFI filter size | | |
|-----------|------------------------------|------------------------------|-------------------------------|
| | C 4200-1051 | D 4200-1071 | E 4200-1111 |
| A | 15mm $\frac{9}{16}$ in | 15mm $\frac{9}{16}$ in | 15mm $\frac{9}{16}$ in |
| B | 160mm $6\frac{5}{16}$ in | 160mm $6\frac{5}{16}$ in | 170mm $6\frac{11}{16}$ in |
| C | 305mm 12 in | 305mm 12 in | 400mm $15\frac{3}{4}$ in |
| D | 15mm $\frac{9}{16}$ in | 15mm $\frac{9}{16}$ in | 15mm $\frac{9}{16}$ in |
| F | 12.5mm $\frac{1}{2}$ in | 12.5mm $\frac{1}{2}$ in | 20mm $\frac{3}{4}$ in |
| G | 6.5mm $\frac{1}{4}$ in | 6.5mm $\frac{1}{4}$ in | 6.5mm $\frac{1}{4}$ in |
| H | 145mm $5\frac{11}{16}$ in | 145mm $5\frac{11}{16}$ in | 145mm $5\frac{11}{16}$ in |
| J | 280mm $11\frac{3}{16}$ in | 280mm $11\frac{3}{16}$ in | 340mm $13\frac{3}{8}$ in |
| K | 25mm 1 in | 25mm 1 in | 50mm $1\frac{15}{16}$ in |
| L | 330mm 13 in | 330mm 13 in | 440mm $17\frac{5}{16}$ in |
| M | 35mm $1\frac{3}{8}$ in | 35mm $1\frac{3}{8}$ in | 35mm $1\frac{3}{8}$ in |
| N | 60mm $2\frac{3}{8}$ in | 60mm $2\frac{3}{8}$ in | 65mm $2\frac{9}{16}$ in |
| P | 45mm $1\frac{3}{4}$ in | 45mm $1\frac{3}{4}$ in | 70mm $2\frac{3}{4}$ in |
| Q | 240mm $9\frac{7}{16}$ in | 240mm $9\frac{7}{16}$ in | 300mm $11\frac{13}{16}$ in |
| S | 80mm $3\frac{1}{8}$ in | 80mm $3\frac{1}{8}$ in | 80mm $3\frac{1}{8}$ in |
| T | 30mm $1\frac{3}{16}$ in | 30mm $1\frac{3}{16}$ in | 30mm $1\frac{3}{16}$ in |
| U | 50mm 2 in | 50mm 2 in | 50mm 2 in |
| V | 40mm $1\frac{9}{16}$ in | 40mm $1\frac{9}{16}$ in | 40mm $1\frac{9}{16}$ in |
| W | 190mm $7\frac{1}{2}$ in | 190mm $7\frac{1}{2}$ in | 200mm $7\frac{7}{8}$ in |
| X | 40mm $1\frac{9}{16}$ in | 40mm $1\frac{9}{16}$ in | 40mm $1\frac{9}{16}$ in |
| Z | M5 x 10mm | M5 x 10mm | M5 x 10mm |
| Terminals | M8 | M8 | M10 |

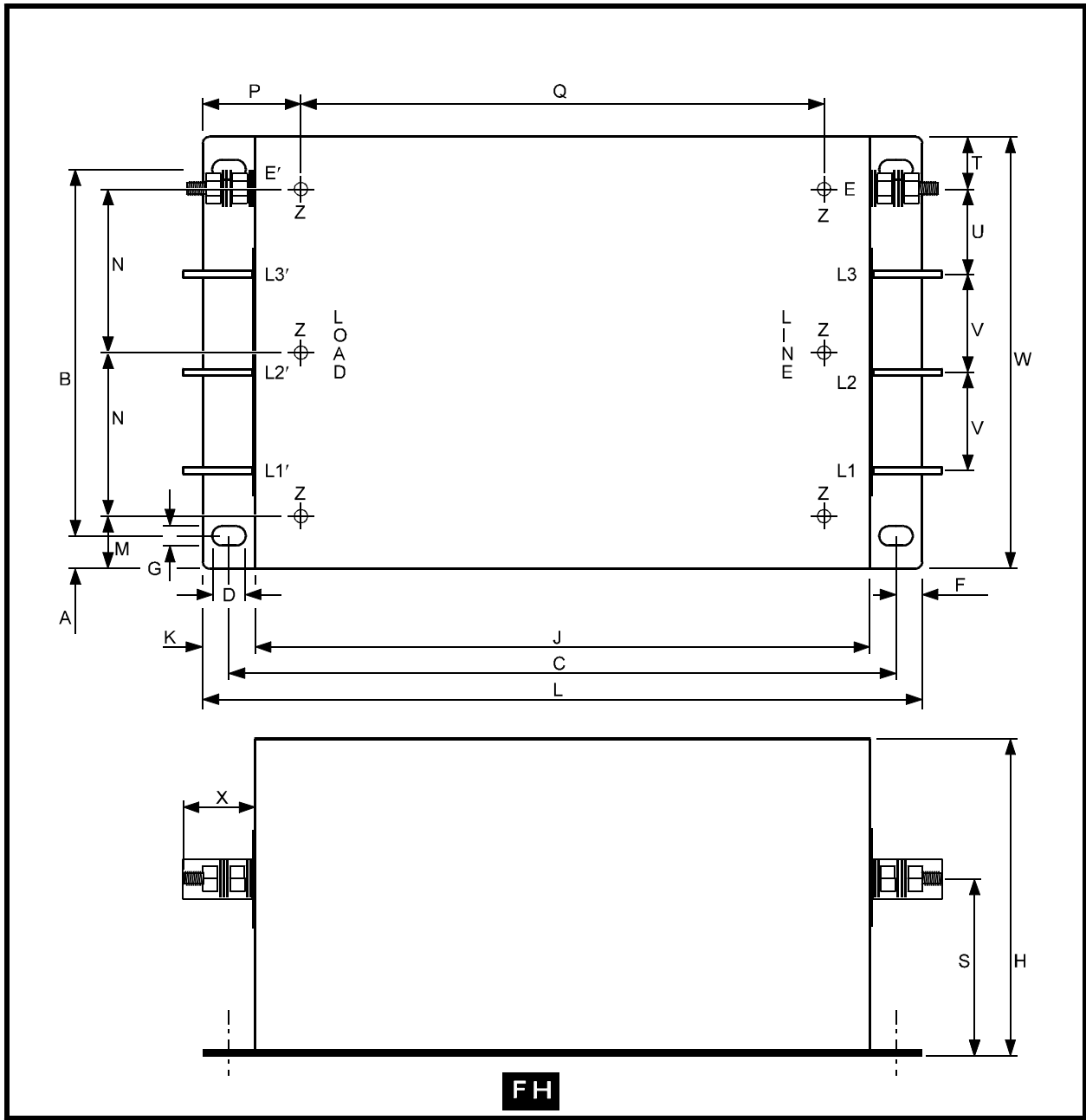

Figure 2-18 Principal dimensions of RFI filter sizes F and H, and the locations of the terminals

| Dimension | RFI filter size | |
|-----------|-------------------------------|------------------------------|
| | F 4200-1171 | H 4200-1220 |
| A | 15mm $\frac{9}{16}$ in | 15mm $\frac{9}{16}$ in |
| B | 170mm $6\frac{11}{16}$ in | 170mm $6\frac{11}{16}$ in |
| C | 400mm $15\frac{3}{4}$ in | 560mm $22\frac{7}{16}$ in |
| D | 15mm $\frac{9}{16}$ in | 15mm $\frac{9}{16}$ in |
| F | 15mm $\frac{9}{16}$ in | 15mm $\frac{9}{16}$ in |
| G | 6.5mm $\frac{1}{4}$ in | 6.5mm $\frac{1}{4}$ in |
| H | 145mm $5\frac{11}{16}$ in | 145mm $5\frac{11}{16}$ in |
| J | 430mm $16\frac{15}{16}$ in | 530mm $20\frac{7}{8}$ in |
| K | 50mm $1\frac{15}{16}$ in | 30mm $1\frac{3}{16}$ in |
| L | 490mm $19\frac{1}{4}$ in | 590mm $23\frac{1}{4}$ in |
| M | 20mm $\frac{3}{4}$ in | 20mm $\frac{3}{4}$ in |
| N | 80mm $3\frac{1}{8}$ in | 80mm $3\frac{1}{8}$ in |
| P | 50mm 2 in | 50mm $1\frac{15}{16}$ in |
| Q | 390mm $15\frac{3}{8}$ in | 490mm $19\frac{5}{16}$ in |
| S | 80mm $3\frac{1}{8}$ in | 72.5mm $2\frac{7}{8}$ in |
| T | 30mm $1\frac{3}{16}$ in | 20mm $\frac{3}{4}$ in |
| U | 50mm 2 in | 50mm $1\frac{15}{16}$ in |
| V | 40mm $1\frac{1}{16}$ in | 45mm $1\frac{3}{4}$ in |
| W | 200mm $7\frac{7}{8}$ in | 200mm $7\frac{7}{8}$ in |
| X | 40mm $1\frac{9}{16}$ in | 40mm $1\frac{9}{16}$ in |

2.6 Power connections



Warning

Electric shock risk

The voltages present in the following locations can cause severe electric shock and may be lethal:

AC supply cables and connections

Output cables and connections

Many internal parts of the Drive, and external option units



Warning

Isolation device

The AC supply must be disconnected from the Drive using an approved isolation device before any cover is removed from the Drive or before any servicing work is performed.



Warning

Stored charge

The Drive contains capacitors that remain charged to a potentially lethal voltage after the AC supply has been disconnected. If the Drive has been energized, the AC supply must be isolated at least ten minutes before work may continue.



Warning

AC supply by plug and socket

Special attention must be given if the Drive is installed in equipment which is connected to the AC supply by a plug and socket. The AC supply terminals of the Drive are connected to the internal capacitors through rectifier diodes which do not give isolation. If the plug terminals can be touched when the plug is disconnected from the socket, a means of automatically isolating the plug from the Drive must be used (eg. a latching relay).



Warning

STOP function

The STOP function does not remove dangerous voltages from the Drive or any external option units.



Warning

Ground leakage current – model sizes 3 and 4

Ground leakage current is typically 9mA*. A fixed ground connection must be made before AC power is applied. In some applications, safety regulations require a duplicate ground connection.

* 9mA at 380V ~ 415V 50Hz AC supply; up to 14mA at 480V 60Hz AC supply. Measured by the method described in IEC950 Annex D.

Ground leakage current – Low Voltage model size 3

Ground leakage current is typically 5mA at 220V 50 Hz. A fixed ground connection must be made before AC power is applied. In some applications, safety regulations require a duplicate ground connection.

Measured by the method described in IEC950 Annex D.

Ground connections (earthing, equi-potential bonding)

The ground terminal of the Drive must be connected to the system ground of the AC supply. The ground wiring must conform to local regulations and codes of practice.

Refer to *Wiring recommendations* later in this chapter.



Warning

The ground loop impedance must conform to the requirements of local safety regulations.

The Drive must be grounded by a connection capable of carrying the prospective fault current until the protective device (fuse, etc) disconnects the AC supply.

The ground connections must be inspected and tested at appropriate intervals.

Power and ground terminals

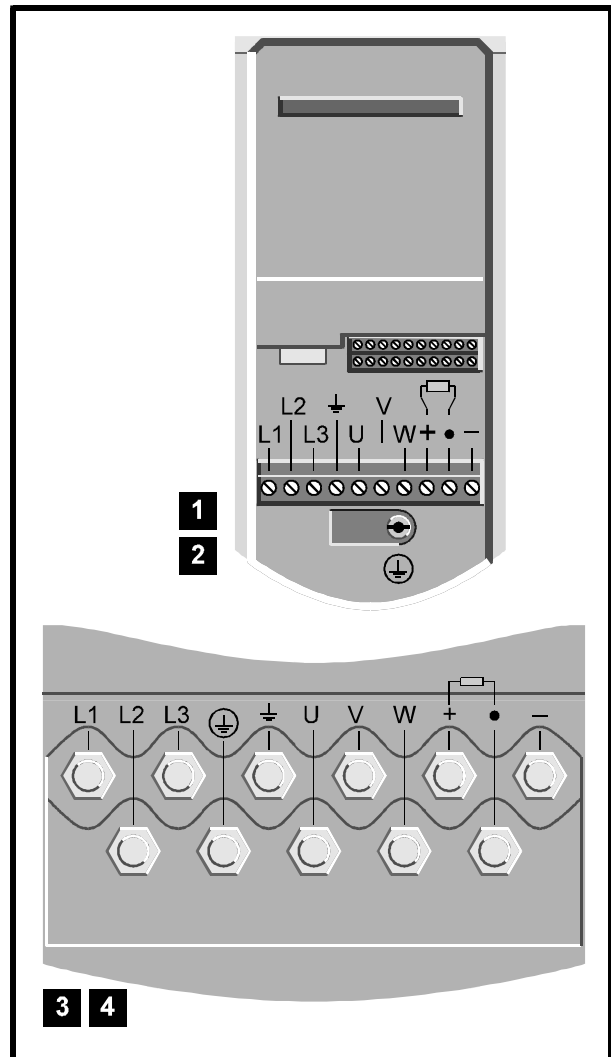

Figure 2-19 Locations of the power and ground terminals

Terminal sizes and tightening torques



Warning

To avoid a fire hazard and maintain validity of the UL listing, adhere to the specified tightening torques for the power and ground terminals. Refer to the following tables.

Drive

Table 2–11 Mechanical data for the Drive terminals

| Model size | Power terminals | | Ground terminal | |
|------------------|------------------------|----------------------|---------------------------|--------------------|
| | Size Type | Torque | Size Type | Torque |
| 1 | Plug-in terminal block | 0.5 N.m 4.4 lb.in | M4 (Torx/slot-head screw) | 3 N.m 2.2 lb.ft |
| 2 | Plug-in terminal block | 0.5 N.m 4.4 lb.in | M4 (Torx/slot-head screw) | 3 N.m 2.2 lb.ft |
| 3 | M10 stud | 15 N.m 11 lb.ft | M10 stud | 15 N.m 11 lb.ft |
| 4 | M10 stud | 15 N.m 11 lb.ft | M10 stud | 15 N.m 11 lb.ft |
| Torque tolerance | | | ±10% | |

RFI filter

Table 2–12 Mechanical data for the RFI filter terminals

| Size | Power terminals | | Ground terminal | |
|------------------|------------------|---------------------|-----------------|---------------------|
| | Size Type | Torque | Size Type | Torque |
| A | Screw terminals | 0.7 N.m 6. lb.in | Screw terminals | 0.7 N.m 0.7 N.m |
| B | Screw terminals | 0.7 N.m 6. lb.in | Screw terminals | 0.7 N.m 0.7 N.m |
| C | M8 stud | 12.6 N.m 9 lb.ft | M8 stud | 12.6 N.m 9 lb.ft |
| D | M8 stud | 12.6 N.m 9 lb.ft | M8 stud | 12.6 N.m 9 lb.ft |
| E | M10 stud | 25 N.m 18 lb.ft | M10 stud | 25 N.m 18 lb.ft |
| F | M10 stud | 25 N.m 18 lb.ft | M10 stud | 25 N.m 18 lb.ft |
| H | M10 bus-bar hole | 25 N.m 18 lb.ft | M10 stud | 25 N.m 18 lb.ft |
| Torque tolerance | | | ± 10% | |

Using the gland plate and cable glands



Warning

When the gland plate(s) are not fitted, objects less than 60mm (2¹/₂ in) wide can pass through the cable entry opening and possibly make contact with live parts inside the Drive.

Fit the gland plate and cable glands as required. Before fitting cable glands, push out sufficient blanking caps from the gland plate.

Note that the IP rating of the Drive is reduced if any holes in the gland plate are left open. The rating is affected as follows:

| | |
|--|------|
| Gland plate not fitted | IP00 |
| Gland plate fitted Unused holes uncovered | IP10 |
| Gland plate and glands fitted Blanking caps covering unused holes | IP40 |

Table 2–13 Diameters of the holes in the gland plate

| Model size | Gland plate hole diameter | |
|------------|--|---|
| | Control signal wiring | Power cables |
| 1 | 20mm ³ / ₄ in | 20mm ³ / ₄ in |
| 2 | 20mm ³ / ₄ in | 20mm ³ / ₄ in |
| 3 | 20mm ³ / ₄ in | 28mm 1 ¹ / ₁₆ in |
| 4 | 20mm ³ / ₄ in | 28mm 1 ¹ / ₁₆ in |

2.7 Wiring recommendations

Observe the wiring recommendations given in this section. Recommendations are given separately for the following:

Routine EMC precautions

- Recommended when strict compliance with emission standards is not required.
- Minimized risk of disturbing adjacent electronic equipment.

Compliance with EMC emission standards

- Strict compliance with emission standards.
- When the Drive is installed in a residential area, or adjacent to sensitive electronic equipment such as radio receivers or similar.

The details of individual installations may vary, but details which are indicated in the recommendations to be important for EMC must be adhered to closely.

For further details when EMC emission requirements are to be met, refer to the *Commander GP EMC Data Sheet* for the size of Drive used.

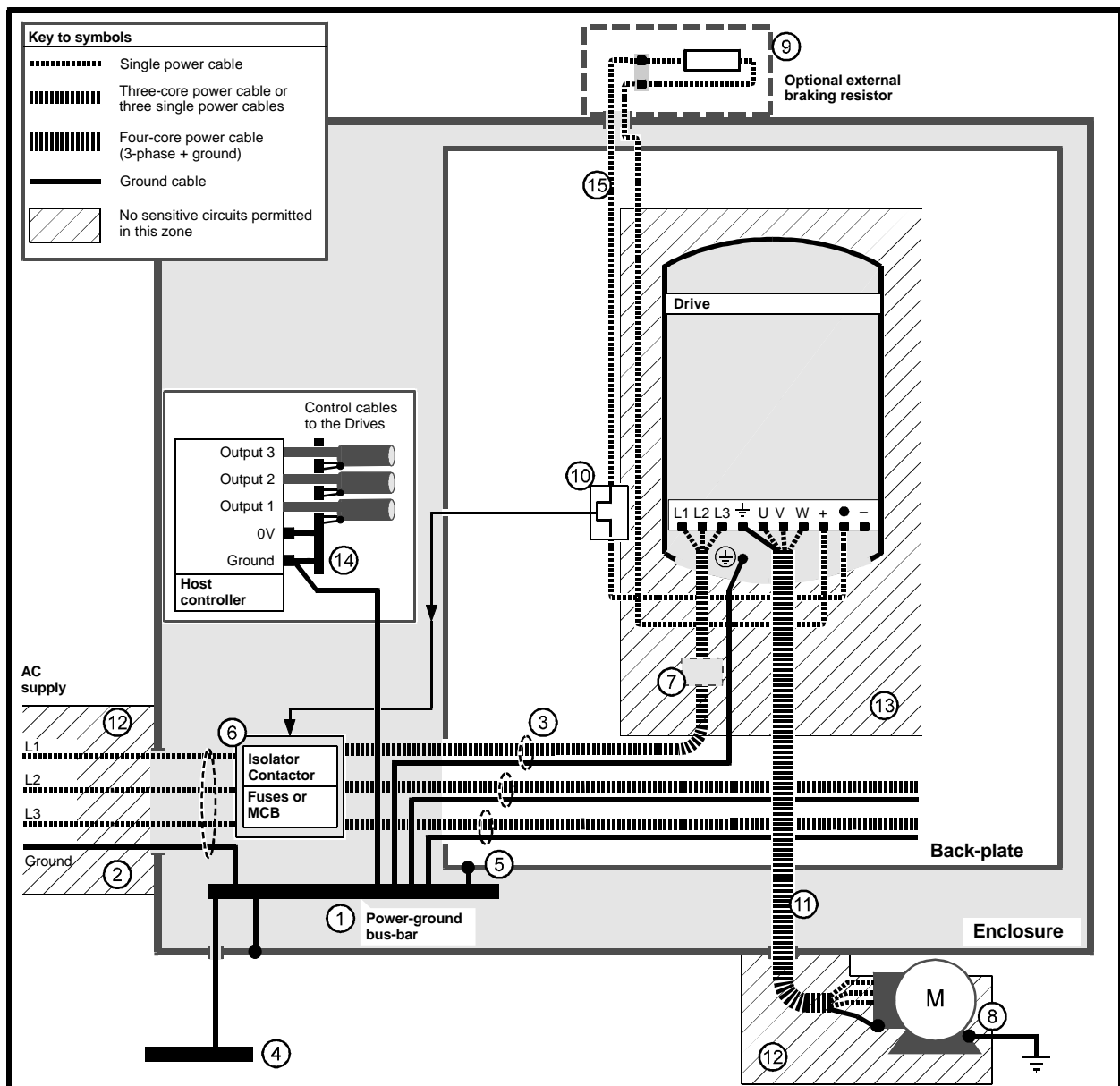

Figure 2-20 Wiring guidelines for routine EMC precautions (model sizes 1 to 4)

Routine EMC precautions (model sizes 1 to 4)

General features

1. Single power-ground bus-bar, or low-impedance ground terminal.
2. Incoming AC supply ground connected to the power ground bus-bar.
3. Connect grounds of any other circuits to the power ground bus-bar.
4. Site ground, if required.
5. Metal back-plate, safety bonded to the power ground bus-bar.
6. System isolator, circuit contactors and fuses/MCB.
7. Alternative position for Drive fuses/MCB.
8. Motor-frame ground connection, if required.
9. Optional braking resistor mounted externally, protected by a metal grille.
10. Thermal protection device to protect the braking resistor.

Routine EMC precautions

11. Use four-core cable to connect the motor to the Drive as shown. The ground conductor in the motor cable must be connected only to the ground terminals of the Drive and motor; it must not be connected directly to the power-ground bus-bar.
12. If the wiring for sensitive signal circuits is to be parallel to an unshielded motor cable (or cables for an unfiltered power supply) for more than 1 metre (3 feet), ensure the separation is at least 0.3m (12 in).
If the parallel run is to exceed 10 metres (30 feet), increase the separation proportionally. For example, if the parallel run is to be 40 metres, the spacing must be $0.3 \times 40 \div 10 = 1.2$ metres.
When a motor-thermistor is used, this constraint does not apply to the cable connecting the thermistor to the Drive. The motor-thermistor cable must be shielded (as shown in Figures 3–4 and 3–5 in the *User Guide*).
13. Do not place sensitive signal circuits in a zone extending 0.3m (12 in) all around the Drive.
14. If the control circuit 0V is to be grounded, this should be done at the system controller (eg. PLC) and not at the Drive. This is to avoid injecting noise currents into the 0V circuit.
15. When the braking-resistor wiring is unshielded, ensure a minimum spacing of 0.3m (12 in) from signal wiring.

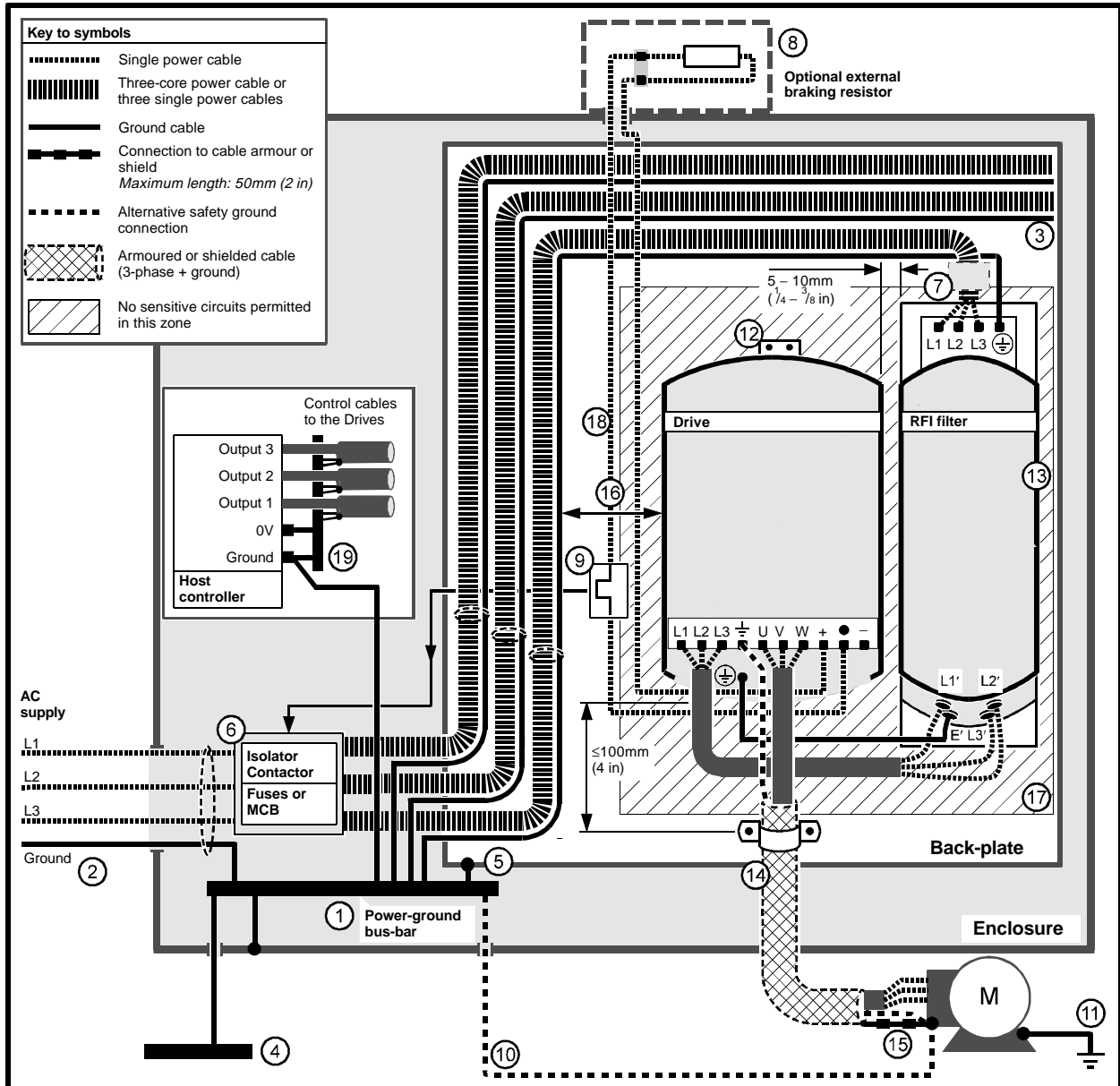

Figure 2-21 Wiring guidelines for compliance with EMC emission standards (model sizes 1 and 2)

Compliance with EMC emission standards (model sizes 1 and 2)

General features

1. Single power ground bus-bar or low-impedance ground terminal.
2. Incoming AC supply ground connected to the power ground bus-bar.
3. Connect grounds of any other circuits to the power ground bus-bar.
4. Site ground if required.
5. Metal back-plate, safety bonded to power ground bus-bar.
6. System isolator, circuit contactors and fuses/MCB.
7. Alternative position for Drive fuses.
8. Optional braking resistor mounted externally, protected and shielded by a metal grille.
9. Thermal overload device to protect the braking resistor.
10. Alternative safety ground for the motor.
11. Motor-frame ground connection, if required.

Special features for EMC

12. Drive heatsink directly grounded to the back-plate using the metal mounting-brackets. Ensure that the screws make direct electrical connection to the back-plate, for example by using screw threads tapped in the backplate.
13. RFI filter mounted at the side of the Drive. Ensure a separation of 5 to 10mm ($\frac{1}{4}$ to $\frac{3}{8}$ in) from the Drive. The RFI filter casing is directly grounded to the back-plate by the fixing screws.
14. A shielded (screened) or steel-wire armoured cable must be used to connect the Drive to the motor. The shield must be bonded to the back-plate using an uninsulated metal cable-clamp. The clamp must be positioned no further than 100mm (4 in) from the Drive.
15. Connect the shield of the motor cable to the ground terminal of the motor frame using a link that is as short as possible and not exceeding 50mm (2 in) in length. A full 360° termination of the shield to the terminal housing of the motor is beneficial.
16. Ensure the AC supply and ground cables are at least 100mm (4 in) from the Drive.
17. Avoid placing sensitive signal circuits in a zone extending 0.3m (12 in) all around the Drive.
18. Unshielded wiring to the optional braking resistor(s) may be used, provided the resistor is either in the same enclosure as the Drive or the wiring does not run external to the enclosure. When the braking-resistor wiring is unshielded, ensure a minimum spacing of 0.3m (12 in) from signal wiring and the AC supply wiring to the RFI filters.
19. If the control circuit 0V is to be grounded, this should be done at the host controller (eg. PLC) and not at the Drive. This is to avoid injecting noise currents into the 0V circuit.

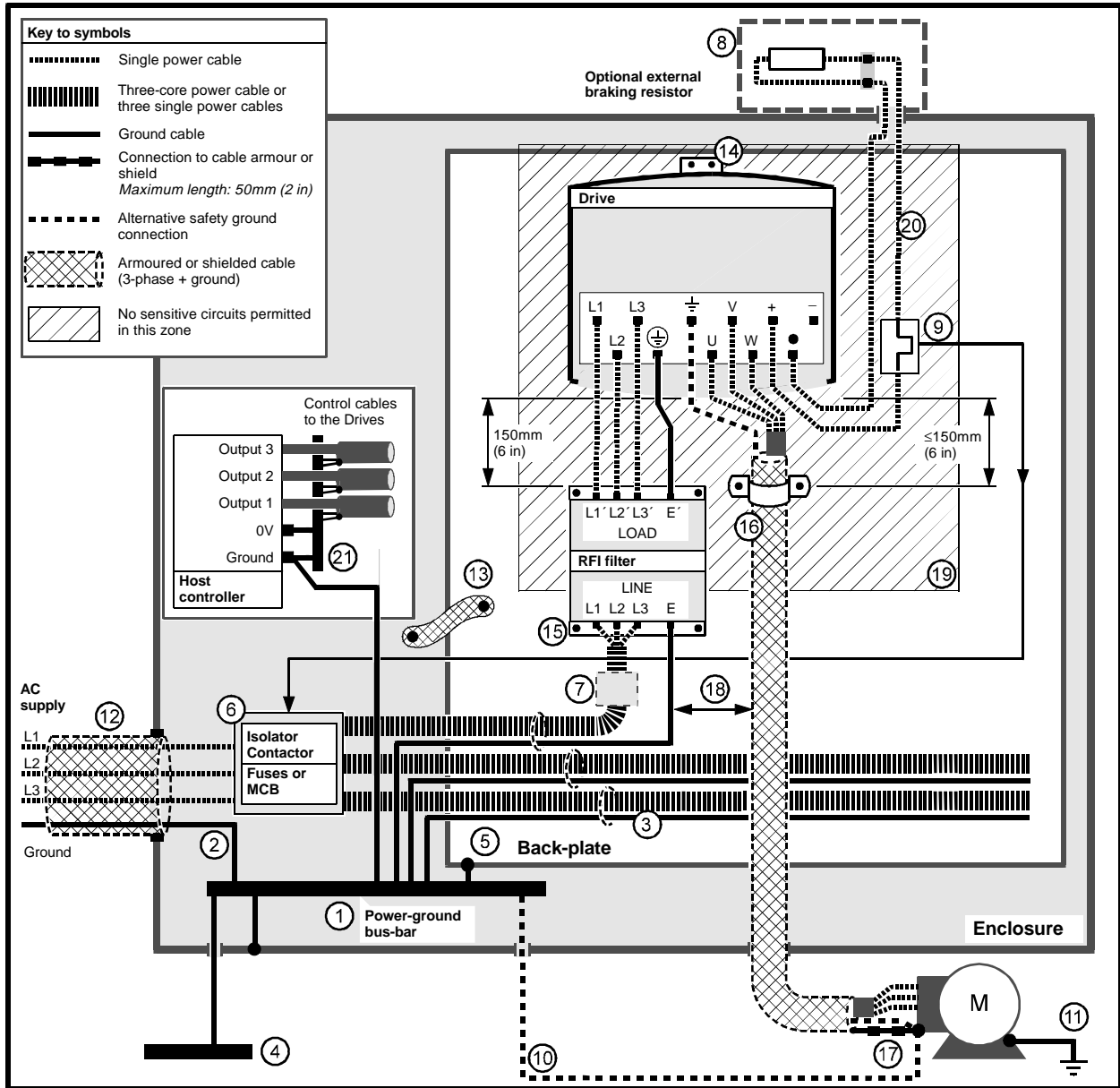

Figure 2-22 Wiring guidelines for compliance with EMC emission standards (model sizes 3 and 4)

Compliance with EMC emission standards (model sizes 3 and 4)

General features

1. Single power ground bus-bar or low-impedance ground terminal.
2. Incoming AC supply ground connected to the power ground bus-bar.
3. Connect grounds of any other circuits to the power ground bus-bar.
4. Site ground if required.
5. Metal back-plate, safety bonded to power ground bus-bar.
6. System isolator, circuit contactors and fuses/MCB.
7. Alternative position for Drive fuses.
8. Optional braking resistor mounted externally, protected and shielded by a metal grille.
9. Thermal overload device to protect the braking resistor.
10. Alternative safety ground for the motor.
11. Motor-frame ground connection, if required.
15. RFI filter mounted 150mm (6 in) from the Drive. The RFI filter casing is directly grounded to the back-plate by the fixing screws. Minimize the length of cables between the Drive and RFI filter.
16. A shielded (screened) or steel-wire armoured cable must be used to connect the Drive to the motor. The shield must be bonded to the back-plate using an uninsulated metal cable-clamp. The clamp must be positioned no further than 150mm (6 in) from the Drive.
17. Connect the shield of the motor cable to the ground terminal of the motor frame using a link that is as short as possible and not exceeding 50mm (2 in) in length. A full 360° termination of the shield to the terminal housing of the motor is beneficial.
18. Ensure the AC supply and ground cables are at least 100mm (4 in) from the motor cable.
19. Avoid placing sensitive signal circuits in a zone extending 0.3m (12 in) all around the Drive.
20. Unshielded wiring to the optional braking resistor(s) may be used, provided the resistor is either in the same enclosure as the Drive or the wiring does not run external to the enclosure. When the braking-resistor wiring is unshielded, ensure a minimum spacing of 0.3m (12 in) from signal wiring and the AC supply wiring to the RFI filters.

Special features for EMC

12. **Size 4 models only** The AC supply cable must be shielded (screened) or steel-wire armoured. Bond the shield or armour to the enclosure wall using standard cable and gland fixings.
13. **Size 4 models only** Back-plate electrically bonded to the enclosure wall using a short, low-inductance connections (eg. two flat, braided cables of 12mm x 2.3mm ($1/2 \times 1/8$ inch) nominal size, or a single braided cable of equivalent dimensions).
14. Drive heatsink directly grounded to the back-plate using fixing screws. Screw threads tapped into the back-plate must be used to ensure that a direct electrical connection is made. An unpainted back-plate (eg. zinc-plated steel) is required.
21. If the control circuit 0V is to be grounded, this should be done at the host controller (eg. PLC) and not at the Drive. This is to avoid injecting noise currents into the 0V circuit.

2.8 Variations in the EMC wiring recommendations

Control wiring

Control wiring which is connected to the Drive and leaves the enclosure must have one of the following additional treatments:

- Pass the control cable(s) through a ferrite ring (part number 3225-1004). More than one cable can pass through a ferrite ring. Ensure the length of cable between the ferrite ring and the Drive is not greater than 125mm (5 in).
- Use one or more cables having a separate overall shield. Bond this shield (s) to the back-plate using an uninsulated metal clamp. Position the clamp not further than 100mm (4 in) from the Drive. Do not make any other connections to either end of the overall shield.

Interruptions to the motor cable

The motor cable should ideally be a single piece of shielded or armoured cable having no interruptions. In some situations it may be necessary to interrupt the cable, as in the following examples:

- Connecting the motor cable to a terminal block in the Drive enclosure
- Fitting a motor isolator switch for safety when work is done on the motor

In these cases the following guidelines should be followed.

Terminal block in the enclosure

The motor cable shields should be bonded to the back-plate using uninsulated metal cable-clamps which should be positioned as close as possible to the terminal block. Keep the length of power conductors to a minimum and ensure that all sensitive equipment and circuits are at least 0.3m (12 in) away from the terminal block.

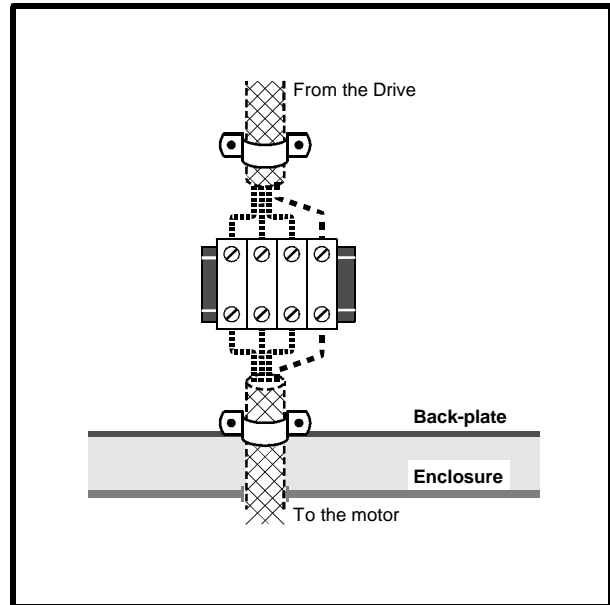

(Refer to *Key to symbols* in Figure 2–21)

Figure 2–23 Connecting the motor cable to a terminal block in the enclosure

Using a motor isolator-switch

The motor cable shields should be connected by a very short conductor having a low inductance. The use of a flat metal coupling-bar is recommended; conventional wire is not suitable.

The shields should be bonded directly to the coupling-bar using uninsulated metal cable-clamps. Keep the length of the exposed power conductors to a minimum and ensure that all sensitive equipment and circuits are at least 0.3m (12 in) away.

The coupling-bar may be grounded to a known low-impedance ground nearby, for example a large metallic structure which is connected closely to the Drive ground.

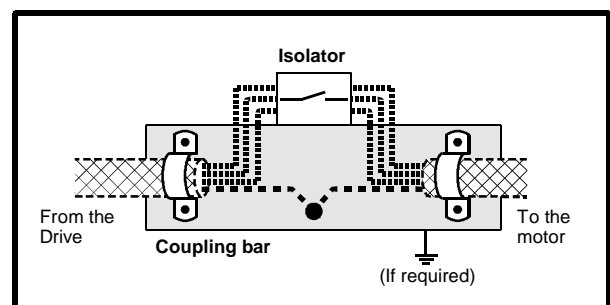

(Refer to *Key to symbols* in Figure 2–21)

Figure 2–24 Connecting the motor cable to an isolator switch

2.9 Signal connections

The signal connections to be made depend on the method of control to be used. Refer to Chapter 2 *Getting Started*, Chapter 3 *Setting up the Drive* and Appendix C *Signal Connections* in the *User Guide*.

This page is intentionally left blank

A Motor Connections

A.1 Cable length

It is not recommended that a Drive is operated with a motor-cable length greater than that specified in the table in *Planning the installation* in Chapter 2. If this is unavoidable, it is recommended that a sinusoidal filter is used to prevent the PWM switching components from entering the motor cable. Sinusoidal filters are available from specialist filter suppliers.

A.2 Multiple motors

If the Drive is to control more than one motor, make connections as shown in Figure A-1. The maximum cable lengths given in the table in Chapter 2 *Installing the Drive* apply to the total length of cable from the Drive to the farthest motor.

It is recommended that each motor is connected through a protection relay since the Drive cannot protect each motor. For star connection, a sinusoidal filter or an output inductor must be connected as shown in Figure A-1, even when the cable lengths are less than the maximum permissible. For details, of inductor sizes refer to a Drive Centre or distributor listed at the end of the User Guide.

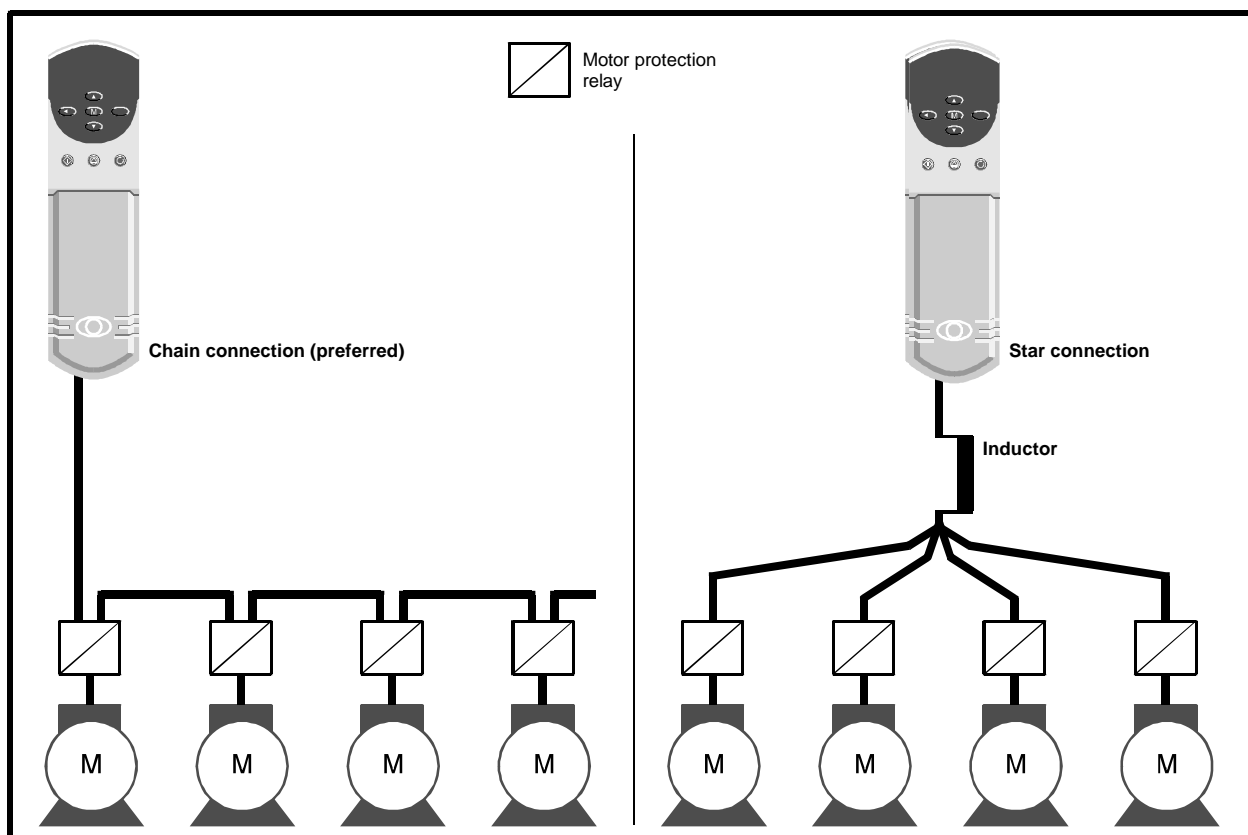

Figure A-1 Connecting motors in parallel

This page is intentionally left blank

B UL Listing Information

The Drive conforms to UL listing requirements only when the following are observed:

- The Drive is installed in a type 1 enclosure, or better, as defined by UL50
- UL-listed fuses class RK1 600VAC are used in the AC supply
- Class 1 60/75°C (140/167°F) copper wire only is used in the installation
- The ambient temperature does not exceed 40°C (104°F) when the Drive is operating
- The terminal tightening torques specified in the table in *Terminal sizes and tightening torques* in Chapter 2 *Installing the Drive* are used

2.1 AC supply specification

The Drive is suitable for use in a circuit capable of delivering not more than 5000 RMS symmetrical Amperes (10 000 RMS symmetrical Amperes for model size 4) at 528VAC RMS maximum.

2.2 Maximum continuous output current

The Drive models are listed as having the maximum continuous output currents (FLC) shown in Table B-1 (see Appendix C *Data* for details).

Table B-1 Maximum continuous output current

| Model | FLC (A) |
|----------------------|----------|
| GPD 1201 GPD 1401 | 2.1 |
| GPD 1202 GPD 1402 | 2.8 |
| GPD 1203 GPD 1403 | 3.8 |
| GPD 1204 GPD 1404 | 5.6 |
| GPD 1205 GPD 1405 | 9.5 |
| GPD 2201 GPD 2401 | 12 |
| GPD 2202 GPD 2402 | 16 |
| GPD 2203 GPD 2403 | 25 |
| GPD 3201 GPD 3401 | 34 |
| GPD 3402 | 40 |
| GPD 3202 GPD 3403 | 46 |
| GPD 3203 GPD 3404 | 60 |
| GPD 3204 GPD 3405 | 74 70 |
| GPD 4401 | 96 |
| GPD 4402 | 124 |
| GPD 4403 | 156 |
| GPD 4404 | 180 |
| GPD 4405 | 202 |

This page is intentionally left blank

C Data

C.1 Drive

Power and current ratings

| Model | Nominal motor power (4-pole motors) | | Maximum permissible continuous output current | | | | | Nominal AC supply current |
|----------------------|--|-------------------|--|--------|--------|--------|--------|------------------------------|
| | 380V | 460V | 3kHz | 4.5kHz | 6kHz | 9kHz | 12kHz | |
| GPD 1201 GPD 1401 | 0.37 kW 0.75 kW | 0.5 HP 1.0 HP | 2.1 A | 2.1 A | 2.1 A | 2.1 A | 2.1 A | 3.1 A |
| GPD 1202 GPD 1402 | 0.55 kW 1.1 kW | 0.75 HP 1.5 HP | 2.8 A | 2.8 A | 2.8 A | 2.8 A | 2.8 A | 3.2 A |
| GPD 1203 GPD 1403 | 0.75 kW 1.5 kW | 1.0 HP 2.0 HP | 3.8 A | 3.8 A | 3.8 A | 3.8 A | 3.8 A | 5.5 A |
| GPD 1204 GPD 1404 | 1.1 kW 2.2 kW | 1.5 HP 3.0 HP | 5.6 A | 5.6 A | 5.6 A | 5.6 A | 4.5 A | 8.4 A |
| GPD 1205 GPD 1405 | 2.2 kW 4.0 kW | 3.0 HP 5.0 HP | 9.5 A | 9.5 A | 8.5 A | 7.0 A | 5.5 A | 9.5 A |
| GPD 2201 GPD 2401 | 3.0 kW 5.5 kW | 4.0 HP 7.5 HP | 12.0 A | 12.0 A | 12.0 A | 12.0 A | 11.7 A | 13.7 A |
| GPD 2202 GPD 2402 | 4.0 kW 7.5 kW | 5.0 HP 10 HP | 16.0 A | 16.0 A | 16.0 A | 14.2 A | 11.7 A | 16.3 A |
| GPD 2203 GPD 2403 | 5.5 kW 11.0 kW | 7.5 HP 15 HP | 25.0 A | 21.7 A | 18.2 A | 14.2 A | 11.7 A | 24.3 A |
| GPD 3201 GPD 3401 | 7.5 kW 15.0 kW | 10 HP 25 HP | 34.0 A | 34.0 A | 34.0 A | 28.0 A | 23.0 A | 34.0 A |
| GPD 3402 | 18.5 kW | 30 HP | 40.0 A | 40.0 A | 37.0 A | 28.0 A | 23.0 A | 39.0 A |
| GPD 3202 GPD 3403 | 11 kW 22.0 kW | 15 HP 30 HP | 46.0 A | 46.0 A | 40.0 A | 32.0 A | 26.6 A | 46.0 A |
| GPD 3203 GPD 3404 | 15 kW 30.0 kW | 20 HP 40 HP | 60.0 A | 47.0 A | 40.0 A | 32.0 A | 26.7 A | 59.0 A |
| GPD 3204 GPD 3405 | 22 kW 37.0 kW | 30 HP 50 HP | 74.0 A 70.0 A | 56.0 A | 46.0 A | 35.0 A | 28.0 A | 74.0 A |
| GPD 4401 | 45 kW | 75 HP | 96 A | 96 A | 88 A | 70 A | | 96 A |
| GPD 4402 | 55 kW | 100 HP | 124 A | 104 A | 88 A | 70 A | | 120 A |
| GPD 4403 | 75 kW | 125 HP | 156 A | 124 A | 105 A | 80 A | | 151 A |
| GPD 4404 | 90 kW | 150 HP | 180 A | 175 A | 145 A | 110 A | | 173 A |
| GPD 4405 | 110 kW | 150 HP | 202 A | 175 A | 145 A | 110 A | | 190 A |

At 50°C ambient temperature

| Model | Maximum permissible continuous output current | | | | |
|----------------------|---|--------|--------|--------|--------|
| | 3kHz | 4.5kHz | 6kHz | 9kHz | 12kHz |
| GPD 1201 GPD 1401 | 2.1 A | 2.1 A | 2.1 A | 2.1 A | 2.1 A |
| GPD 1202 GPD 1402 | 2.8 A | 2.8 A | 2.8 A | 2.8 A | 2.8 A |
| GPD 1203 GPD 1403 | 3.8 A | 3.8 A | 3.8 A | 3.8 A | 3.3 A |
| GPD 1204 GPD 1404 | 5.6 A | 5.6 A | 5.1 A | 4.0 A | 3.3 A |
| GPD 1205 GPD 1405 | 6.9 A | 5.9 A | 5.1 A | 4.0 A | 3.3 A |
| GPD 2201 GPD 2401 | 12.0 A | 12.0 A | 12.0 A | 11.6 A | 9.7 A |
| GPD 2202 GPD 2402 | 16.0 A | 16.0 A | 14.7 A | 11.6 A | 9.7 A |
| GPD 2203 GPD 2403 | 20.0 A | 17.3 A | 14.7 A | 11.6 A | 9.7 A |
| GPD 3201 GPD 3401 | 34.0 A | 34.0 A | 28.0 A | 21.0 A | 17.9 A |
| GPD 3402 | 40.0 A | 34.0 A | 28.0 A | 21.0 A | 17.9 A |
| GPD 3202 GPD 3403 | 44.0 A | 36.0 A | 31.0 A | 24.0 A | 20.6 A |
| GPD 3203 GPD 3404 | 44.0 A | 36.0 A | 31.0 A | 24.0 A | 20.9 A |
| GPD 3204 GPD 3405 | 50.0 A | 41.0 A | 34.0 A | 26.0 A | 23.0 A |
| GPD 4401 | 95 A | 85 A | 75 A | 60 A | |
| GPD 4402 | 105 A | 85 A | 75 A | 60 A | |
| GPD 4403 | 135 A | 105 A | 85 A | 65 A | |
| GPD 4404 | 180 A | 150 A | 125 A | 95 A | |
| GPD 4405 | 190 A | 150 A | 125 A | 95 A | |

AC supply requirements

Voltage:
Standard: 380V to 480V ±10%
LV: 200V to 240V ±10%

No. of phases: 3

Maximum supply imbalance:
2% negative phase sequence (equivalent to 3% voltage imbalance between phases)

Frequency range: 48 to 62 Hz

Line reactors

Line reactors reduce the risk of damage to the Drive resulting from severe disturbances on the supply network. As a result of the following, for example;

- Power factor correction equipment is connected close to the Drive
- Large DC Drives having no or ineffective line reactors are connected to the supply
- Direct-on-line started motor(s) are connected to the supply and when any of these motors are started, a dip is produced in excess of 20% of the actual supply voltage

...excessive peak current may flow in the input power circuit of the Drive. Such disturbances may cause nuisance tripping or in extreme cases, failure of the Drive.

When one of the following model sizes:

GPD1201 GPD1401
 GPD1202 GPD1402
 GPD1203 GPD1403
 GPD1204 GPD1404

are used on an AC supply where one of the conditions described above is in existence, **OR** the supply is 175kVA or larger, it is recommended that a line reactor of 2% reactance is included between the AC supply and the Drive. Model sizes 1405 and larger have an internal DC bus choke.



RFI filters (for EMC purpose) do not give adequate protection against these conditions.

Caution

For three-phase Drives, three individual reactors, or a single three-phase reactor should be used. Each Drive must have its own reactor(s).

Current ratings

Continuous: Not less than the continuous current rating of the Drive

Repetitive peak: Not less than *twice* the continuous current of the Drive.

Motor requirements

Number of phases: 3

Voltage:
 Standard: 380V ~ 480V
 LV: 200V ~ 240V

Temperature, humidity and cooling method

Ambient temperature range:
 0°C to 50°C (32°F to 122°F). Output current de-rating must be applied at ambient temperatures between 40°C (104°F) and 50°C (122°F) (absolute maximum).

Minimum temperature at power-up: -10°C (14°F)

Cooling method: Forced convection

Maximum humidity:
 95% non-condensing at 40°C (104°F)

Storage temperature range:
 -40°C to 50°C (-40°F to 122°F)

Maximum storage time: After each 12 months, the capacitors will need re-forming; refer to the supplier of the Drive.

Altitude

Altitude range: 0 to 4000m (13000 ft), subject to the following conditions:

1000m to 4000m (3300 ft to 13000 ft) above sea level: de-rate the maximum output current from the specified figure by 1% per 100m (330 ft) above 1000m

Vibration

Tested to ≤0.5g as specified in IEC 68-2-34

Ingress protection

Gland plate(s) not fitted: IP00

Gland plate(s) fitted; cable glands not fitted: IP10

Gland plate(s) fitted; cable-glands fitted:
 IP40, NEMA 1

Overall dimensions

- H Height including surface mounting brackets
- W Width
- D Projection forward of panel when surface mounted
- F Projection forward of panel when through-panel mounted
- R Projection rear of panel when through-panel mounted

| Dimension | Model size | | | |
|-----------|--------------------|--------------------|--------------------|----------------------|
| | 1 | 2 | 3 | 4 |
| H | 366mm 14 1/4 in | 366mm 14 1/4 in | 368mm 14 3/8 in | 765mm 30 1/8 in |
| W | 95mm 3 3/4 in | 190mm 7 1/2 in | 375mm 14 3/4 in | 500mm 19 11/16 in |
| D | 200mm 7 7/8 in | 200 mm 7 7/8 in | 260mm 10 1/4 in | 260mm 10 1/4 in |
| F | 120mm 4 1/4 in | 120mm 4 1/4 in | 120mm 4 1/4 in | 120mm 4 1/4 in |
| R | 80mm 3 1/8 in | 80mm 3 1/8 in | 140mm 5 1/2 in | 140mm 5 1/2 in |

Weights

| Model size | kg | lb |
|------------|----|-----|
| 1 | 4 | 8.8 |
| 2 | 8 | 17 |
| 3 | 22 | 49 |
| 4 | 70 | 154 |

Electromagnetic compatibility (EMC)

This is a summary of the EMC performance of the Drive. For full details, refer to the *Commander GP EMC Data Sheet* which can be obtained from a Drive Centre or distributor listed at the end of the User Guide.

Immunity

Compliance with immunity standards does not depend on installation details. Drives meet EN50082-2 (generic immunity standard for the industrial environment) and the following specifications from the IEC6100-4 group (derived from IEC801):

Part 2, Electrostatic discharge: Level 3

Part 3, Radio frequency field: Level 3

Part 4 Transient burst:

Level 4 at the control terminals

Level 3 at the power terminals

Part 5, Surge (at the AC supply terminals)

(as specified by EN50082-2 informative annex):

Level 4 line-to-ground

Level 3 line-to-line

Part 6, Conducted radio frequency: Level 3

Emission

Compliance with emission standards depends on rigorous adherence to the installation guidelines, including the use of the specified RFI filter in the AC supply circuit. Compliance also depends on the PWM switching frequency used in the output stage of the Drive, and the length of the motor cable. For full details, refer to the *Commander GP EMC Data Sheet* which can be obtained from a Drive Centre or distributor listed at the end of the User Guide.

When installed according to the instructions the Drive can meet the emission requirements of CENELEC generic emission standards, as follows:

| GP Drive | EN50081-1 conducted | EN50081-1 radiated | EN50081-2 conducted | EN50081-2 radiated |
|----------|-------------------------------|--------------------|---------------------|--------------------|
| 1 | Restricted motor cable length | No | Yes | Yes |
| 2 | Restricted motor cable length | No | Yes | Yes |
| 3 | No | No | Yes | Yes |

The optional RFI filter specified below must be used:

| Drive model | Use RFI filter... | |
|----------------------|-------------------|-------------|
| | Type | Part number |
| GPD 1201 GPD 1401 | A | 4200-0010 |
| GPD 1202 GPD 1402 | A | 4200-0010 |
| GPD 1203 GPD 1403 | A | 4200-0010 |
| GPD 1204 GPD 1404 | A | 4200-0010 |
| GPD 1205 GPD 1405 | A | 4200-0010 |
| GPD 2201 GPD 2401 | B | 4200-0027 |
| GPD 2202 GPD 2402 | B | 4200-0027 |
| GPD 2203 GPD 2403 | B | 4200-0027 |
| GPD 3201 GPD 3401 | C | 4200-1051 |
| GPD 3402 | C | 4200-1051 |
| GPD 3202 GPD 3403 | C | 4200-1051 |
| GPD 3203 GPD 3404 | D | 4200-1071 |
| GPD 3204 GPD 3405 | D | 4200-1071 |
| GPD 4401 | E | 4200-1111 |
| GPD 4402 | F | 4200-1172 |
| GPD 4403 | F | 4200-1172 |
| GPD 4404 | F | 4200-1172 |
| GPD 4405 | H | 4200-1220 |

Power Drive Systems standard EN61800-3

The Drive meets the immunity requirements of EN61800-3 irrespective of the environment in which it is operating.

The emission requirements of this standard are also met depending on the environment category, as shown in the table at the bottom of the page:

EN61800-3 defines the following:

- The **first environment** as one that includes domestic premises. It also includes establishments directly connected without intermediate transformers to a low-voltage power supply network which supplies buildings used for domestic purposes.
- The **second environment** is one that includes all establishments other than those directly connected to a low-voltage power supply network which supplies buildings used for domestic purposes.
- **Restricted distribution** is defined as a mode of sales distribution in which the manufacturer restricts the supply of equipment to suppliers, customers or users who separately or jointly have technical competence in the EMC requirements of the application of Drives.

Note

If a Power Drive System is included as part of equipment covered by a separate EMC product standard, the EMC standard for the complete equipment applies.

Frequencies and speed

PWM switching frequency

3kHz nominal (selectable up to 12kHz)

Maximum output frequency: 1000Hz

Speed regulation: 1 ~ 2%

Speed control range: >50:1

Starts per hour

By electronic control: unlimited

By interrupting the AC supply:

model sizes 1 and 2: ≤20

model sizes 3 and 4: ≤10

| Power Drive Systems standard EN61800-3 | | |
|---|--|--------------------------|
| Model size | Environment category | |
| | First environment | Second environment |
| GPD 1201 - GPD 1205 GPD 1401 ~ GPD 1405 (Rated input current of Drive <25A) | Restricted distribution only: specified RFI filter required | No RFI filter required * |
| GPD 2201, GPD 2202 GPD 2401, GPD 2402 (Rated input current of Drive <25A) | Restricted distribution only: specified RFI filter required | No RFI filter required * |
| GPD 2203 GPD 2403 (Rated input current of Drive >25A) | Specified RFI filter required | No RFI filter required * |
| GPD 3201 - GPD 3204 GPD 3401 ~ GPD 3405 (Rated input current of Drive >25A) | Specified RFI filter required | No RFI filter required * |
| GPD 4401 ~ GPD 4405 (Rated input current of Drive >25A) | Using the specified RFI filters and following the wiring guidelines given in Figure 2-23 may not ensure that the radiated emission limits are met. Additional filtering may be required in this environment. | No RFI filter required * |

* RFI filter(s) recommended where sensitive electronic systems are operating nearby.

Accuracy and resolution

The following data applies to the Drive only; it does not include the performance of the source of the control signals.

Frequency resolution...

Preset frequency reference: 0.1Hz

Precision frequency reference: 0.001Hz

Frequency accuracy...

Preset frequency reference: 0.03Hz or 0.01% of the reference, whichever is the larger value

Precision frequency reference: 0.0001Hz or 0.01% of the reference, whichever is the larger value

C.2 Optional RFI filters

Ratings

| Type | Part number | Max. continuous current | Ingress protection |
|------|-------------|-------------------------|--------------------|
| A | 4200-0010 | 10 A | IP20 |
| B | 4200-0027 | 27 A | IP20 |
| C | 4200-1051 | 50 A | IP 00 |
| D | 4200-1071 | 75 A | IP 00 |
| E | 4200-1111 | 110 A | IP 00 |
| F | 4200-1172 | 170 A * | IP 00 |
| H | 4200-1220 | 220 A | IP 00 |

* Above 40°C (104°F), the current rating is reduced by 1.6A/°C (0.88A/°F) up to 50°C (122°F).

Maximum current overload:

150% of rated current for 1 minute in a 10 minute period.

Voltage (phase-to-phase and phase-to-ground):
480V +10%

AC supply frequency: 48 to 62 Hz

Temperature

| Type | Part number | Maximum ambient temperature at rated current | Case temperature rise at rated current |
|------|-------------|--|--|
| A | 4200-0010 | 50 °C (122°F) | <30°C (86°F) |
| B | 4200-0027 | 50 °C (122°F) | <40°C (104°F) |
| C | 4200-1051 | 50 °C (122°F) | <40°C (104°F) |
| D | 4200-1071 | 50 °C (122°F) | <40°C (104°F) |
| E | 4200-1111 | 50 °C (122°F) | <40°C (104°F) |
| F | 4200-1172 | 40 °C (104°F) * | <55°C (131°F) |
| H | 4200-1220 | 50 °C (122°F) | <40°C (104°F) |

* Above 40°C (104°F), the current rating is reduced by 1.6A/°C (0.88A/°F) up to 50°C (122°F).

Power dissipation

| Type | Part number | Power dissipation at rated current |
|------|-------------|------------------------------------|
| A | 4200-0010 | 25 W |
| B | 4200-0027 | 40 W |
| C | 4200-1051 | 60 W |
| D | 4200-1071 | 100 W |
| E | 4200-1111 | 120 W |
| F | 4200-1172 | 150 W |
| H | 4200-1220 | 200 W |

Ground leakage current

Ground-leakage current when the AC supply is 400V at 50Hz is as follows:

Commander GP

| Condition | A | B | C to H |
|--|-------|--------|--------|
| Balanced supply phase-to-phase and phase to ground | 5.6mA | 7.4mA | 55mA |
| One phase disconnected | 41mA | 57.9mA | 350mA |

Commander GP LV

| Condition | A | B | C to D |
|--|-------|-------|--------|
| Balanced supply phase-to-phase and phase to ground | 3.4mA | 4.4mA | 33mA |
| One phase disconnected | 25mA | 35mA | 210mA |

For other AC supply voltages and frequencies, scale the values of leakage current proportionally.

Discharge resistors

A and B: 330K Ω in a star network between phases, with the star point connected by a 1M Ω resistor to ground.

C to H: 10M Ω between each phase and ground.

The discharge resistors are fitted internally.

Overall dimensions

| Type | Part number | Dimension | | |
|------|-------------|---|--|---|
| | | H | W | D |
| A | 4200-0010 | 396mm 15 ⁹ / ₁₆ in | 50mm 1 ¹⁵ / ₁₆ in | 114.5mm 4 ¹ / ₂ in |
| B | 4200-0027 | 406mm 16 in | 75mm 2 ¹⁵ / ₁₆ in | 114.5mm 4 ¹ / ₂ in |
| C | 4200-1051 | 330mm 13 in | 190mm 7 ¹ / ₂ in | 145mm 5 ¹¹ / ₁₆ in |
| D | 4200-1071 | 330mm 13 in | 190mm 7 ¹ / ₂ in | 145mm 5 ¹¹ / ₁₆ in |
| E | 4200-1111 | 440mm 17 ⁵ / ₁₆ in | 200mm 7 ⁷ / ₈ in | 145mm 5 ¹¹ / ₁₆ in |
| F | 4200-1172 | 490mm 19 ¹ / ₄ in | 200mm 7 ⁷ / ₈ in | 145mm 5 ¹¹ / ₁₆ in |
| H | 4200-1220 | 590mm 23 ³ / ₄ in | 200mm 7 ⁷ / ₈ in | 145mm 5 ¹¹ / ₁₆ in |

Weights

| Type | Part number | kg | lb |
|------|-------------|------|----|
| A | 4200-0010 | 2 | 5 |
| B | 4200-0027 | 2.7 | 6 |
| C | 4200-1051 | 7.4 | 16 |
| D | 4200-1071 | 8 | 18 |
| E | 4200-1111 | 12.3 | 27 |
| F | 4200-1172 | 16 | 35 |
| H | 4200-1220 | 26 | 57 |