



User Guide

Modbus Plus

Option Module for
Unidrive

Part Number: 0400-0035
Issue Number: 2



SAFETY INFORMATION

Persons supervising and performing the electrical installation or maintenance of a Drive and/or an external Option Unit must be suitably qualified and competent in these duties. They should be given the opportunity to study and if necessary to discuss this User Guide before work is started.

The voltages present in the Drive and external Option Units are capable of inflicting a severe electric shock and may be lethal. The Stop function of the Drive does not remove dangerous voltages from the terminals of the Drive and external Option Unit. Mains supplies should be removed before any servicing work is performed.

The installation instructions should be adhered to. Any questions or doubt should be referred to the supplier of the equipment. It is the responsibility of the owner or user to ensure that the installation of the Drive and external Option Unit, and the way in which they are operated and maintained complies with the requirements of the Health and Safety at Work Act in the United Kingdom and applicable legislation and regulations and codes of practice in the UK or elsewhere.

The Drive software may incorporate an optional Auto-start facility. In order to prevent the risk of injury to personnel working on or near the motor or its driven equipment and to prevent potential damage to equipment, users and operators, all necessary precautions must be taken if operating the Drive in this mode.

The Stop and Start inputs of the Drive should not be relied upon to ensure safety of personnel. If a safety hazard could exist from unexpected starting of the Drive, an interlock should be installed to prevent the motor being inadvertently started.

GENERAL INFORMATION

The manufacturer accepts no liability for any consequences resulting from inappropriate, negligent or incorrect installation or adjustment of the optional operating parameters of the equipment or from mismatching the Drive with the motor.

The contents of this User Guide are believed to be correct at the time of printing. In the interests of a commitment to a policy of continuous development and improvement, the manufacturer reserves the right to change the specification of the product or its performance, or the contents of the User Guide, without notice.

All rights reserved. No part of this User Guide may be reproduced or transmitted in any form or by any means, electrical or mechanical including photocopying, recording or by any information storage or retrieval system, without permission in writing from the publisher.

Copyright:	© November 99 Control Techniques SSPD
Author:	Paul Bennett
Issue Code:	2
System File:	V2.07.05

Contents

1. INTRODUCTION	1
1.1. UD70 WITH MODBUS PLUS INTERFACE	1
2. MECHANICAL INSTALLATION	3
2.1. UNIDRIVE	3
3. ELECTRICAL INSTALLATION	5
3.1. MODBUS PLUS CONNECTOR	5
3.2. MODBUS PLUS CONNECTIONS	5
3.3. MODBUS PLUS NETWORK TERMINATION	6
3.4. MODBUS PLUS CABLE	6
3.5. MAXIMUM NETWORK LENGTH	7
4. GETTING STARTED	9
4.1. QUICK START	9
4.2. MODBUS PLUS NODE ADDRESS	9
4.3. MODBUS PLUS DATA RATE	10
4.4. NEGATIVE NUMBER FORMAT	10
4.4.1. Sign plus Magnitude	11
4.4.2. 2's Complement	11
4.4.3. Sign/Magnitude and 2's Complement	12
4.5. INITIALISING SET-UP CHANGES	12
4.6. NETWORK STATUS LED	13
4.7. NETWORK STATUS INDICATION	13
5. CYCLIC DATA	15
5.1. WHAT IS CYCLIC DATA?	15
5.2. MAPPING PARAMETERS ON UNIDRIVE	16
5.2.1. Global OUT Data	16
5.2.2. Global IN Data	16
5.3. INTERNAL 32-BIT PARAMETERS ON UD70	17
5.3.1. Global OUT Data	17
5.3.2. Global IN Data	18
5.4. CHANGING THE CYCLIC DATA MAPPINGS	19
5.4.1. Resetting the UD70 with Modbus Plus Interface	19
5.5. SAVING UNIDRIVE PARAMETERS	20
5.5.1. Menu 1 to 19	20
5.5.2. Menu 20 and PLC Parameters	20
5.6. MAPPING CONFLICTS	20
5.6.1. Control Word Mapping Conflicts	21
5.7. CONTROL WORD FOR UNIDRIVE	21
5.8. STATUS WORD FOR UNIDRIVE	24
5.9. EXAMPLE NETWORK 1	25

5.10.	EXAMPLE NETWORK 2	26
6.	NON-CYCLIC DATA CHANNEL	27
6.1.	SUPPORTED NON-CYCLIC COMMANDS	27
6.1.1.	PRESET SINGLE REGISTERS	27
6.1.2.	PRESET MULTIPLE REGISTERS	27
6.1.3.	READ MULTIPLE REGISTERS	27
7.	DIAGNOSTICS	29
7.1.	FIELDBUS CODE	29
7.2.	SYSTEM FILE VERSION	30
7.3.	NODE ADDRESS	30
7.4.	NETWORK DATA RATE	30
7.5.	NETWORK STATUS	30
7.6.	TRIP ACTION ON NETWORK LOSS	31
7.7.	OTHER UNIDRIVE TRIP CODES	32
8.	APPENDIX	35
8.1.	MODBUS PLUS NETWORK OPERATION	35
8.2.	ERROR DETECTION	35

1. Introduction

NOTE

Drive parameters are denoted in this manual by “#MM.PP”, where MM refers to the menu number, and PP refers to the parameter number within that menu. Please refer to the Unidrive manual for parameter definitions.

1.1. UD70 with Modbus Plus Interface

The UD70 with Modbus Plus interface for Unidrive is supplied in a large option module package. The Modbus Plus interface uses the UD70 Applications card as a host. An 80C152 processor and System Protocol Chip handle all Modbus Plus network activity, and a Dual-Port RAM interface is used to transfer data between the Modbus Plus layer and the UD70.

The UD70 retains full functionality, allowing the user to download normal DPL application programs. No program modifications are required to allow existing DPL programs to run. A different UD70 operating system file (“MBPLUS.SYS”) is used, and the UD70 has this system file pre-loaded. The UD70 also uses a second DPRAM interface to transfer data to and from the drive.

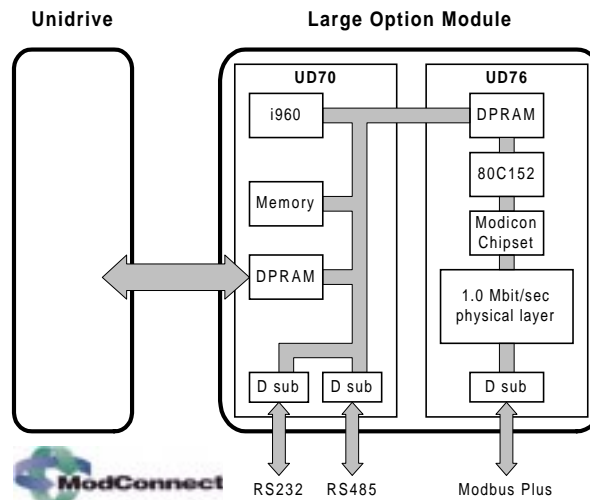

2. Mechanical Installation

NOTE

The Unidrive must be disconnected from the mains supply before installing or removing an option module.

2.1. Unidrive

Isolate the drive from the main supply and allow 5 minutes for the DC Bus capacitors to discharge.

Insert the UD70 with Modbus Plus interface module as shown below. Ensure that it is correctly inserted. The module will click firmly into place.

To remove the module, pull on the black tab, and the module will disengage from the connector and pull out of the drive.

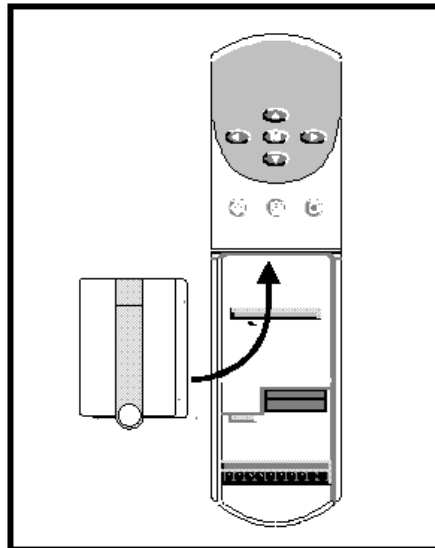

3. Electrical Installation

3.1. Modbus Plus Connector

The UD70 with Modbus Plus Interface has single 9-way D-type socket connector (B) to connect to the Modbus Plus network.

Connectors C and D on the UD70 with Modbus Plus interface are the RS232 (C) and RS485 (D) ports of the UD70.

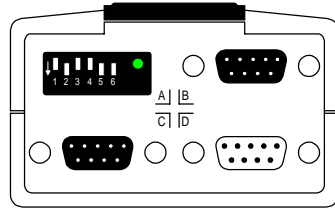

UD70 with Modbus Plus Interface for Unidrive

The pin connections for the Modbus Plus connector are given in the table below.

Function	Terminal	Description
Data+	2	Positive Data Line
Data-	3	Negative Data Line
Screen	1	Cable screen

3.2. Modbus Plus Connections

To connect a node to the Modbus Plus network, make the connections as shown in the diagram below

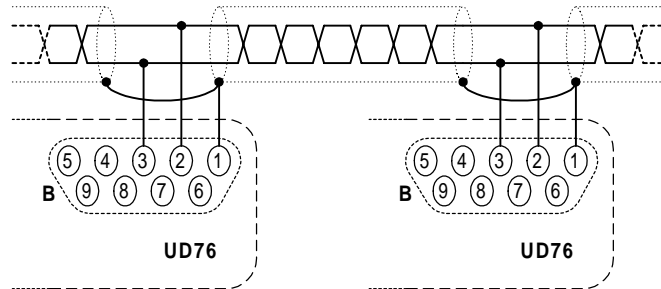

Modbus Plus Network Connections

The Modbus Plus network uses Bi-Phase S signalling which is non-phasic, i.e. it does not matter which wire is linked to Data+ and Data-.

3.3. Modbus Plus Network Termination

There is no termination resistor supplied on the UD70 with Modbus Plus Interface. It is the user's responsibility to ensure that both ends of each section of network cable are correctly terminated.

A 120Ω 0.25W resistor should be connected between the DATA+ and DATA- lines at each end of the main trunk cable, as shown in the diagram below.

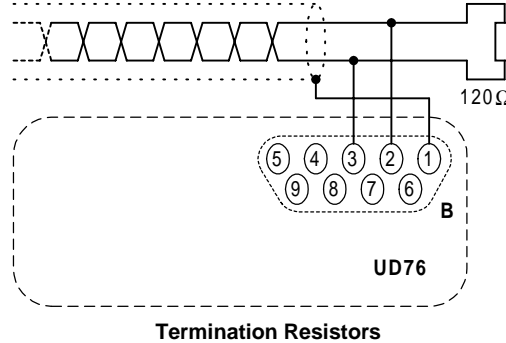

NOTE

The above method of connecting the termination resistor ensures that the network remains terminated when the Modbus Plus connector is disconnected from the node.

It is very important in high-speed communications networks that the network communications cable is correctly terminated. Failure to terminate the network properly may mean that the network operates with substantially reduced noise immunity, or in the worst case, the network doesn't work at all.

3.4. Modbus Plus Cable

Modbus Plus networks (like most fieldbus systems) run at high data rates, and consequently require cable specifically designed to carry high frequency signals. Low quality cable may attenuate the signals, and thus render the signal unreadable for the other nodes on the network. Cable specifications (and recommended cable types) are available on the Modicon web site at "www.modicon.com".

NOTE

Control Techniques can only guarantee correct and reliable operation of the Modbus Plus interface if the network cable installed has been fully approved by ModConnect.

3.5. Maximum Network Length

The maximum network length of a Modbus Plus network (without the use of repeaters) is 450m, with up to 32 nodes connected.

Repeaters can be used to extend the maximum network length, or increase the number of nodes on the network. The Modbus Plus specification allows a maximum of 3 repeaters to be used on a network, and this allows a network to be extended to 1800m. The maximum number of nodes, even with 3 repeaters, is limited to 64.

Number of Repeaters	Maximum network length (m)	Maximum number of nodes
0	450	32
1	900	64
2	1350	64
3	1800	64

Full details about network specifications are suitable repeaters are available on the Modicon web site at "www.modicon.com".

4. Getting Started

The Quick Start section shows the basic parameter configurations required for the Modbus Plus interfaces to establish communications. Detailed descriptions of each parameter function follow later in this chapter.

4.1. Quick Start

The UD70 with Modbus Plus interface is configured using parameters within the Unidrive, and DIP switches on the front of the module itself. The parameters listed in the table below should be configured on each node BEFORE connecting the node to the Modbus Plus network.

Function	Unidrive	Recommended Setting
Node Address	DIP Switches (See #20.01 after reset)	2 to 64
Network Data Rate	Fixed	
Negative Number Format	#20.02	1

The UD70 with Modbus Plus interface is configured using parameters within the Unidrive. Parameters should be configured on each node BEFORE connecting the node to the Modbus Plus network.

The LED should flash once per second for 5 seconds while the interface initialises, and changes to 6 flashes per second when initialisation has been completed and the node has joined the network.

4.2. Modbus Plus Node Address

Unidrive: #20.01 (Read Only)

Every node must be given a unique network address. If a node is assigned an address, and that address already exists on the Modbus Plus network, the node may prevent the network from operating. The valid range of addresses is from 1 and 64.

The network address is configured by setting the DIP switches on the UD70 with Modbus Plus interface. The table of settings is given below.

Node Addr	DIP Switch	Node Addr	DIP Switch	Node Addr	DIP Switch
	123456		123456		123456
1	111111	23	100101	45	110010
2	011111	24	000101	46	010010
3	101111	25	111001	47	100010
4	001111	26	011001	48	000010
5	110111	27	101001	49	111100
6	010111	28	001001	50	011100
7	100111	29	110001	51	101100
8	000111	30	010001	52	001100
9	111011	31	100001	53	110100
0	011011	32	000001	54	010100
11	101011	33	111110	55	100100
12	001011	34	011110	56	000100
13	110011	35	101110	57	111000
14	010011	36	001110	58	011000
15	100011	37	110110	59	101000
16	000011	38	010110	60	001000
17	111101	39	100110	61	110000
18	011101	40	000110	62	010000
19	101101	41	111010	63	100000
20	001101	42	011010	64	000000
21	110101	43	101010		
22	010101	44	001010		

Changes in node address will only take effect after a full reset and re-initialisation of the UD70 with Modbus Plus interface. (See section 4.5.)

4.3. Modbus Plus Data Rate

The data rate is fixed at 1.0Mbits/sec for Modbus Plus networks.

4.4. Negative Number Format

Unidrive: #20.02

There are two formats available for handling negative numbers in the UD70 with Modbus Plus interface. When Modbus Plus was originally developed for Modicon PLCs, they could not handle negative numbers, so a "sign plus magnitude" method was included to allow this to be achieved. Most modern digital equipment can handle negative numbers, and use the "2's-complement" system.

#20.02	Format	Comment
0	Sign + Magnitude	The most significant bit (b15) is set to 0 for positive numbers, and 1 for negative numbers. Remaining bits give the magnitude.
1	2's Complement	UD70 and Unidrive use the 2's complement method to represent negative numbers internally. This the most widely used format for representing negative numbers.
2	Mixed	2's complement format for cyclic data transfer, with sign + magnitude for non-cyclic data transfers.

To maintain backward compatibility in Modbus Plus modules, both systems have been included, and the desired mode must be configured. (Default mode is the same as old Modbus Plus modules.)

4.4.1. Sign plus Magnitude

The method employed to handle negative numbers was to use a "sign plus magnitude" format, where the most significant bit set is to 1 to represent a negative number, and the remaining 15 bits represent the magnitude of the number.

b15	b14	b13	b12	b11	b10	b9	b8	
Sign	Magnitude				Magnitude			

b7	b6	b5	b4	b3	b2	b1	b0
Magnitude				Magnitude			

For example, 300 in decimal is 0x012C in hex. To convert this to a value of -300 in sign plus magnitude format, simply set the most significant bit (b15) to 1. (0x812C)

4.4.2. 2's Complement

The "2's complement" is a true negative number format, that does not require any special number handling for maths on negative numbers. The UD70 with Modbus Plus interface uses the signed 16-bit number format that is common only virtually all digital equipment today.

This format should be used in nearly all cases, with the only exception being when the module is replacing a module in an existing system. This will allow backward compatibility, and does not require and changes to the PLC program.

b15	b14	b13	b12	b11	b10	b9	b8
M6	M5	#18.33	M3	M2	M1	M0	#18.32

b7	b6	b5	b4	b3	b2	b1	b0
#18.31	#1.46	#1.45	Trip	#6.32	#6.31	#6.30	#6.15

For example, 300 in decimal is 0x012C in hex. To convert this to a value of -300 in 2's complement format, invert each bit and 1 to the value produced. (0xFED4)

4.4.3. Sign/Magnitude and 2's Complement

Modbus Plus modules with system file V2.07.03 and earlier only support the non-cyclic data transfer using the PRESET SINGLE REGISTER, PRESET MULTIPLE REGISTERS and READ MULTIPLE REGISTERS commands.

A special mode has been included that will interpret data received using these commands using the "sign plus magnitude" format, while any cyclic data transfers using global data are coded using the "2's complement" format.

NOTE

The hex codes 0x812C and 0xFED4 will appear as an incorrect value if the wrong format is used. The "sign plus magnitude" format will return -300 and -32468, while the 2's complement will produce values of -32468 and -300.

4.5. Initialising Set-up Changes

Modbus Plus configuration parameters and switch settings are only read during the initialisation sequence of the Modbus Plus interface, thus preventing unpredictable network behaviour while parameters are being edited. When parameters have been configured, the UD70 with Modbus Plus interface must be reset to implement the changes in network set-up.

The UD70 can be reset from the Unidrive keypad in 2 ways.

- Set #MM.00 to 1070 and press the red RESET button. This will implement any changes made to the Modbus Plus configuration, but the changes will NOT be stored. If power is lost to the drive, the changes made will be lost, and the UD70 will revert to the stored configuration.
- Set #17.19 to 1. This causes a full reset of the UD70, and implements any changes made to the Modbus Plus configuration. It will also force the UD70 to store the #20.PP parameters in FLASH memory, thus ensuring that the changes will not be lost when power is removed from the drive. The UD70 will reset #17.19 to 0, when the reset sequence is complete.

4.6. Network Status LED

The Network Activity LED flashes in distinctive patterns to indicate network status. The following table summarises these status indications:

Flash Sequence	Description
6 flashes per sec	Normal operation - token is being passed around the network successfully.
1 flash per sec	The node is initialising or reconfiguring. This phase should last approximately 5 seconds.
2 flashes, OFF for 2 secs	The node is never receiving the token.
3 flashes, OFF for 1.7 secs	The node is the sole station, and cannot find any other node with which to exchange the token.
4 flashes, OFF for 1.4 secs	Another node has been detected as having the same node address

4.7. Network Status Indication

Unidrive: #20.50

The status of the network is also displayed in #20.50. If it displays -1 or -2, then the Modbus Plus network has malfunctioned. This can be caused the loss of the network connection, specifying a duplicate node address, or an internal hardware failure. If it displays zero or a positive number, then the Modbus Plus interface is functioning correctly.

#20.50	Indication	Description
>0	Network OK	Indicates the number of data registers being transferred (input and output) per second.
0	Network OK	The node is exchanging the token with the rest of the network, but no data is being transferred to or from the node.
-1	Network Failure	Token not being received, node is the only station on the network, or there is an internal hardware failure.
-2	Duplicate Node Address	Another node on the network has an identical node address.

5. Cyclic Data

Unlike systems such as Interbus-S, Profibus-DP and DeviceNet, Modbus Plus does not have a network master controller. Therefore, IN data is defined as data coming IN to a node, while OUT data is transmitted OUT from the node. The UD70 with Modbus Plus interface provides 3 IN and 3 OUT 16-bit data slots, and 5 IN and 5 OUT 32-bit data slots.

5.1. What is Cyclic Data?

Cyclic data is a method of data transfer that must be set-up during network configuration, but is transmitted automatically once configuration is complete. The high-speed data transfer is achieved by transmitting 16-bit data values over the Modbus Plus network, and relying on local mapping information within the drive to ensure the correct data is sent to the correct locations. This method relies on each node writing and reading data values to and from the registers allocated to the node during network configuration.

The Modbus Plus “global data” facility is used to implement the cyclic data feature. Coupled with the flexibility of the UD70 with Modbus Plus interface and Unidrive, a node can access any drive parameter, and place it in an OUT slot. This value will be transmitted to every other node on the network using the global data feature. A remote node can pick up the data value from the global data, transfer it to an IN slot and write to any read-write drive parameter.

32-bit data values can also be transferred using the global data mechanism. This allows internal UD70 integer variables to be sent to other nodes on the network. This is achieved by using two 16-bit data words for each value. Up to five 32-bit data values can be sent on cyclic data.

NOTE

The mapping configuration cannot be changed dynamically, as a full RESET of the UD70 with Modbus Plus Interface must be performed before the any mapping changes become active.

5.2. Mapping Parameters on Unidrive

The mapping for Unidrive and UD70 with Modbus Plus interface is set using menu 20 parameters. Changes to the mapping parameters will only take effect when the UD70 has been reset.

5.2.1. Global OUT Data

The mapping control parameters are shown in the table below.

Slot	Data Source Mapping Parameter
OUT Slot 1	#20.10 (MMPP)
OUT Slot 2	#20.11 (MMPP)
OUT Slot 3	#20.12 (MMPP)

The data source parameters in the Unidrive is entered in the form MMPP, where MM is the menu number and PP is the parameter number. Any read/write or read only parameter may be defined as a data source parameter.

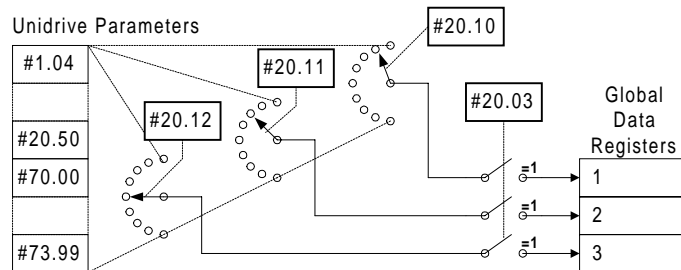

5.2.2. Global IN Data

The mapping control parameters are shown in the table below.

Slot	Data Destination Mapping Parameter	Source Node and Register Number
IN Slot 1	#20.05 (MMPP)	#20.04 (NNRR)
IN Slot 2	#20.07 (MMPP)	#20.06 (NNRR)
IN Slot 3	#20.09 (MMPP)	#20.08 (NNRR)

The data destination parameters are entered in the form MMPP, where MM is the menu number and PP is the parameter number. Any read/write or read only parameter may be defined as a data source parameter.

The source node and source global data register are entered in the form NNRR, where NN is the source node address, and RR is the global register which contains the data value. (The Unidrive control and status words can be accessed as #90.11.)

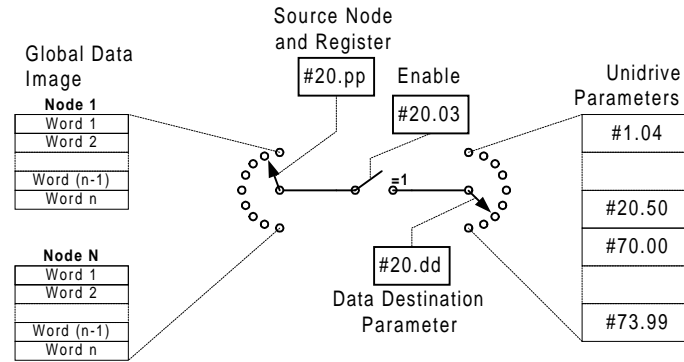

If any mapping parameter is set to an invalid value (target parameter is read-only or does not exist), the mapping will revert to 0 when the UD70 is reset. If a slot is not being used, it can be disabled by setting the mapping to 0.

5.3. Internal 32-Bit Parameters on UD70

In addition to the three 16-bit data slots, five 32-bit data words can also be transferred using cyclic data. This is achieved by using pairs of 16-bit data words in the Modbus Plus global data. The number of words to be transferred in the global data slots is set in #20.13, and allows up to five 32-bit data words to be transferred using the Modbus Plus global data mechanism.

5.3.1. Global OUT Data

The source of OUT cyclic data is fixed, with the first word coming from _R0%, and subsequent words from _R1% to _R4%, depending on how many words are being sent. DPL code is required to ensure that data is moved to the _Rx% registers for transmission.

Slot	Data Source Register (Parameter)
OUT Slot 4,5	_R0% (#72.00)
OUT Slot 6,7	_R1% (#72.01)
OUT Slot 8,9	_R2% (#72.02)
OUT Slot 10,11	_R3% (#72.03)
OUT Slot 12,13	_R4% (#72.04)

As the data source parameters are fixed for the five 32-bit data words, no mapping is required for these data words.

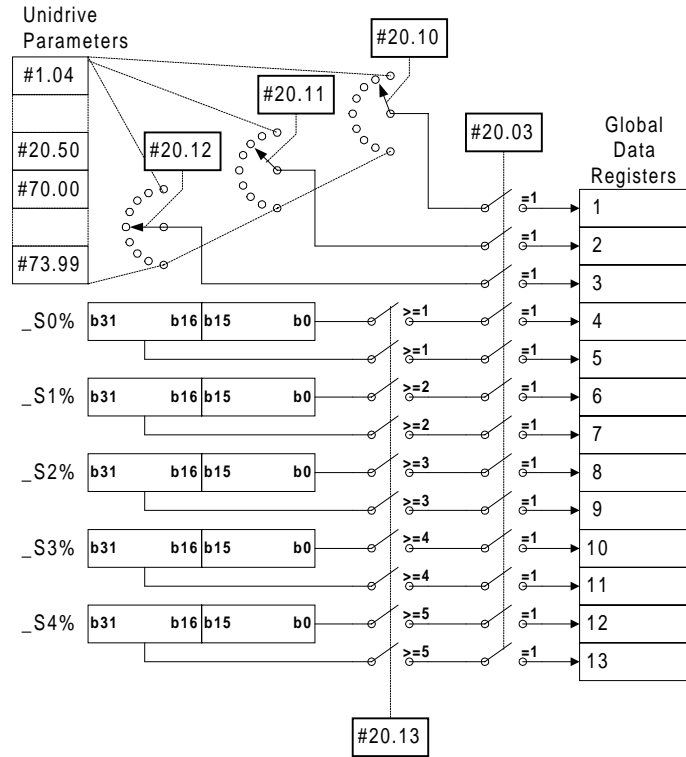

5.3.2. Global IN Data

The destination of IN cyclic data is fixed, with the first word being written to `_S0%`, with subsequent words being written to `_S1%` to `_S4%`, depending on how many words are being sent. The DPL program can access IN data directly from these registers for use in the program.

Slot	Data Destination Register (Parameter)	Source Node and Register Number
IN Slot 4,5	<code>_S0%</code> (#73.00)	#20.15 (NNRR)
IN Slot 6,7	<code>_S1%</code> (#73.01)	#20.16 (NNRR)
IN Slot 8,9	<code>_S2%</code> (#73.02)	#20.17 (NNRR)
IN Slot 10,11	<code>_S3%</code> (#73.03)	#20.18 (NNRR)
IN Slot 12,13	<code>_S4%</code> (#73.04)	#20.19 (NNRR)

Although the destination parameters are fixed for the five 32-bit IN data words, the source node and register must be specified for each word.

The mapping is specified as NNRR where NN is the source node and RR is the global data register from that node.

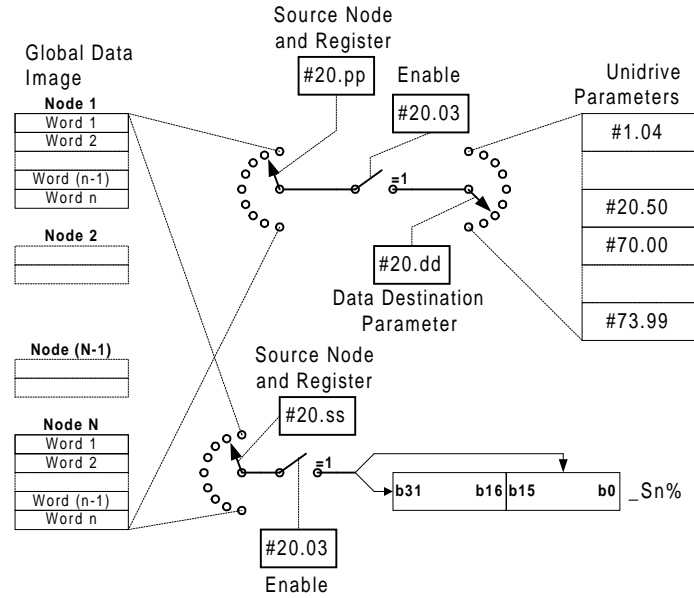

5.4. Changing The Cyclic Data Mappings

The UD70 with Modbus Plus interface must be reset before the changes will take effect. This prevents any corruption of the drive parameters as a mapping parameter is changed to its new value at the keypad.

5.4.1. Resetting the UD70 with Modbus Plus Interface

To reset the UD70 from the Unidrive keypad, set #MM.00 to 1070 and press the red RESET button on the keypad.

5.5. Saving Unidrive Parameters

5.5.1. Menu 1 to 19

All parameters #1.PP to #19.PP are saved in the EEPROM in the Unidrive. To initiate the non-volatile save sequence set #MM.00 (parameter 0 in any menu) to 1000 and press the red RESET button on the keypad.

5.5.2. Menu 20 and PLC Parameters

All #20.PP parameters and PLC parameters (_Pxx% and _Qxx%) are stored in the flash memory of the UD70. If the UD70 is moved to another drive, all #20.PP mapping parameter values will be retained in the module.

To initiate the non-volatile save sequence for these parameters, set #17.19 to 1. The UD70 will then save menu 20, clear #17.19 to zero, and reset. The Modbus Plus interface itself will also be reset, and there can be a delay of 7 seconds before data transfer over Modbus Plus will restart..

#20.PP and PLC parameters can also be stored automatically at power-down, by setting #17.20 to 1. (This parameter change must be stored and the drive reset before it will take effect.)

5.6. Mapping Conflicts

When the mapping parameters for the Modbus Plus cyclic data are set, care must be taken to ensure that there are no clashes with the mapping of the analogue and digital inputs within the drive. The UD70 with Modbus Plus Interface will NOT indicate if there is a conflict of mapping parameters. This only applies to analogue and digital inputs, and IN data mappings for the Modbus Plus global data.

If a numerical parameter is written to from two different sources, the value of this parameter will depend entirely upon the scan times for the analogue or digital input and the Modbus Plus network. Further confusion may be caused due to the update rate of the display. A parameter may appear to be steady at a particular value, but occasionally glitch in the value will be seen. In reality, this value may be changing continuously, leading to erratic drive behaviour.

Drive Input	Unidrive Mapping Parameter	Drive Input	Unidrive Mapping Parameter
Analogue Input 1	#7.10	Digital Input 1	#8.10
Analogue Input 2	#7.14	Digital Input 2	#8.13
Analogue Input 3	#7.18	Digital Input 3	#8.16
Easy Mode Slot 1	#20.10	Digital Input 4	#8.19
Easy Mode Slot 2	#20.11	Digital Input 5	#8.21
Easy Mode Slot 3	#20.12	Digital Input 6	#8.23

To ensure that there are no mapping conflicts, check that each Unidrive mapping parameter has a different value programmed. Analogue and digital inputs can be de-programmed by setting the mapping parameter value to 0.

5.6.1. Control Word Mapping Conflicts

The most common mistake with mapping conflicts occurs when using the control word. By default, the RUN, DIRECTION and JOG signals are controlled from the digital input terminals on the drive, so the control word will be over-riden by the drive terminals. Terminal control **MUST** be disabled before the control word will take effect.

The table below shows the parameters that may be affected by mapping conflicts within the drive.

Unidrive	
#6.15	#1.46
#6.30	#18.31
#6.31	#18.32
#6.32	#18.33
#1.45	

5.7. Control Word for Unidrive

The Control Word is an efficient way of remotely controlling the motion of a drive. Each bit in the control word has a particular function, and provides a method of controlling the function of the drive (RUN, JOG, etc.) with a single data word. The control word is addressed in the UD70 by writing to #90.11.

b15	b14	b13	b12	b11	b10	b9	b8
M6	M5	#18.33	M3	M2	M1	M0	#18.32

b7	b6	b5	b4	b3	b2	b1	b0
#18.31	#1.46	#1.45	Trip	#6.32	#6.31	#6.30	#6.15

The bits shown as "Mx" are individual mask bits that allow the corresponding "bx" to be masked. The "Trip" bit will cause a "tr52" trip when set to 1, but the trip cannot be cleared until b4 has been reset to 0. Parameters #18.31 to #18.33 are general user parameters and do not have mask bits.

Unidrive and UD70 with Modbus Plus Interface		
Bit	Parameter	Description
0	#6.15	Drive enable
1	#6.30	Sequencing bit 0
2	#6.31	Sequencing bit 1
3	#6.32	Sequencing bit 2
4	Trip	Drive Trip (tr52)
5	#1.45	Pre-set select 0
6	#1.46	Pre-set select 1
7	#18.31	Application bit 1
8	#18.32	Application bit 2
9	M0	Mask bit 0
10	M1	Mask bit 1
11	M2	Mask bit 2
12	M3	Mask bit 3
13	#18.33	Application bit 3
14	M5	Mask bit 5
15	M6	Mask bit 6

NOTE

If an Mx bit is reset to 0, the corresponding bit "bx" will remain at the previous value set.

All direct control of the sequencing bits (#6.30 - #6.32) from digital inputs must be disabled before the control word will can be used. (Set #8.16, #8.19 and #8.21 to another value or 0.) The sequencing bits have the following functions when set to 1.

Parameter	Sequencing bit	PLC Mode (#6.04 = 3)	Wire-proof PLC Mode (#6.04 = 4)
#6.15	Enable	Enable	Enable
#6.30	0	Run	Run Forward
#6.31	1	Jog	Jog
#6.32	2	Reverse	Run Reverse

ENABLE the display will show "Inh" when set at 0, and depends on #6.30 and #6.32 when set to 1. Setting #6.15 to 0 will override #6.30 and #6.32, and immediately disables the drive. The motor will coast to rest if it is running when the drive is disabled.

JOG the jog bit must be set, along with the appropriate run and direction signals.

To reset the drive using the Modbus Plus network, use the non-cyclic channel to set #10.38 to 100. The drive will immediately clear #10.38 back to 0 and reset. (See Unidrive manual for more information.)

Some example control word values for the Unidrive are given in the tables below.

b15-b12	b11-b8	b7-b4	b3-b0	Value	Action (Wire-proof PLC mode)
0000	0010	0000	0000	0x0200	Drive disable
0001	1110	0000	0001	0x1E01	Enabled + stopped
0001	1110	0000	0011	0x1E03	Enabled + run fwd
0001	1110	0000	1001	0x1E09	Enabled + run rev
0001	1110	0000	1101	0x1E0C	Enabled + jog rev

b15-b12	b11-b8	b7-b4	b3-b0	Value	Action (PLC mode)
0000	0010	0000	0000	0x0200	Drive disable
0001	1110	0000	0001	0x1E01	Enabled + stopped
0001	1110	0000	0011	0x1E03	Enabled + run fwd
0001	1110	0000	1011	0x1E0B	Enabled + run rev
0001	1110	0000	1111	0x1E07	Enabled + jog rev

5.8. Status Word for Unidrive

The status word is an efficient way of remotely monitoring and diagnosing the status of the drive. Each bit in the status word indicates the status of a particular function of the drive, e.g. at speed, zero speed, drive healthy, etc., and provides a quick method of checking the current status of the drive. The status word is addressed in the UD70 by reading from #90.11.

b15	b14	b13	b12	b11	b10	b9	b8
X	#10.15	#10.14	#10.13	#10.12	#10.11	#10.10	#10.09

b7	b6	b5	b4	b3	b2	b1	b0
#10.08	#10.07	#10.06	#10.05	#10.04	#10.03	#10.02	#10.01

Unidrive - UD70 with Modbus Plus Interface		
Bit	Parameter	Description
0	#10.01	Drive healthy
1	#10.02	Drive running
2	#10.03	Zero speed
3	#10.04	Running at or below min speed
4	#10.05	Below set speed
5	#10.06	At speed
6	#10.07	Above set speed
7	#10.08	Load reached
8	#10.09	In current limit
9	#10.10	Regenerating
10	#10.11	Dynamic brake active
11	#10.12	Dynamic brake alarm
12	#10.13	Direction commanded
13	#10.14	Direction running
14	#10.15	Mains Loss
15	X	Not used

5.9. Example Network 1

The network below shows a possible data transfer requirement for a draw line application. Node 10 passes a master speed reference to each of the following drives, which modify the reference as required. Nodes 11 and 12 pass their final calculated speed demand to nodes 12 and 13 respectively, where the appropriate speed reference is calculated.

Nodes 11, 12 and 13 pass a signal back to node 10, so that it can compare, re-calculate and adjust the master line speed if required.

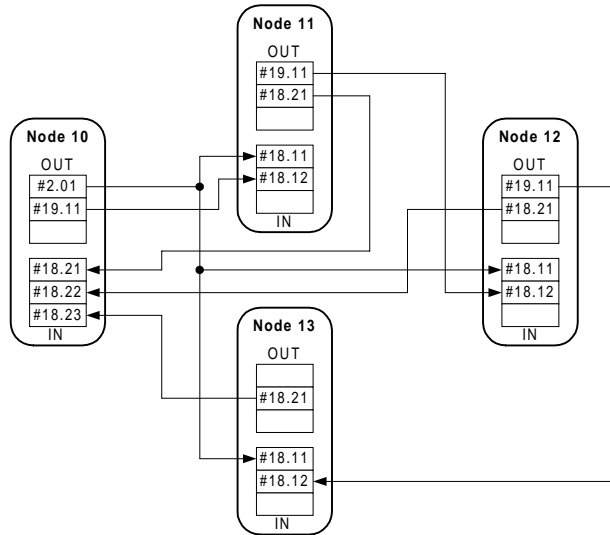

The diagram above shows parameter links that need to be set up, and the table below shows the parameter settings required in each node.

Param	Function	Node 10	Node 11	Node 12	Node 13
#20.04	IN slot 1 source node/slot	1102	1001	1001	1001
#20.05	IN slot 1 destination	1821	1811	1811	1811
#20.06	IN slot 2 source node/slot	1202	1002	1101	1201
#20.07	IN slot 2 destination	1822	1812	1812	1812
#20.08	IN slot 3 source node/slot	1302	----	----	----
#20.09	IN slot 3 destination	1823	----	----	----
#20.10	OUT slot 1 source	201	1911	1911	----
#20.11	OUT slot 2 source	1911	1821	1821	1821
#20.12	OUT slot 3 source	----	----	----	----

"----" indicates that the parameter should be set to 0.

5.10. Example Network 2

The network below shows an alternative arrangement to the first example. This solution uses a PLC to perform all system calculations, and each drive receives a speed reference and control word over the Modbus Plus network, and responds with the current drive speed and status word.

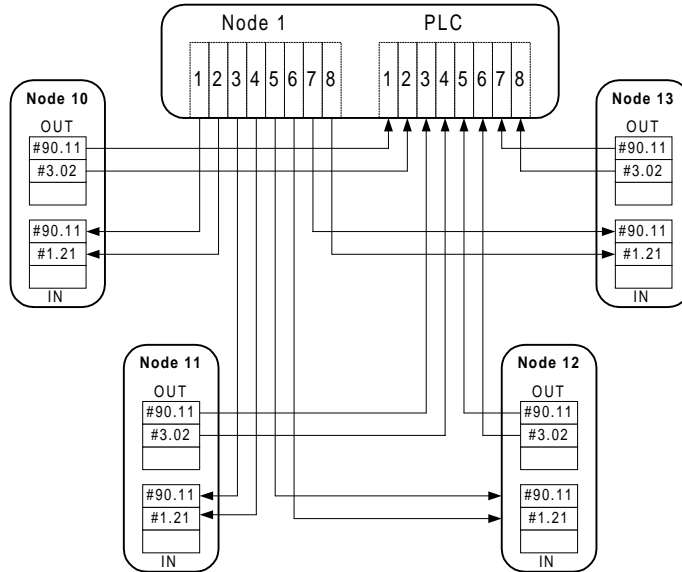

The diagram above shows parameter links that need to be set up, and the table below shows the parameter settings required in each node.

Param	Function	Node 10	Node 11	Node 12	Node 13
#20.04	IN slot 1 source node/slot	101	103	105	107
#20.05	IN slot 1 destination	121	121	121	121
#20.06	IN slot 2 source node/slot	102	104	106	108
#20.07	IN slot 2 destination	9011	9011	9011	9011
#20.08	IN slot 3 source node/slot	----	----	----	----
#20.09	IN slot 3 destination	----	----	----	----
#20.10	OUT slot 1 source	9011	9011	9011	9011
#20.11	OUT slot 2 source	302	302	302	302
#20.12	OUT slot 3 source	----	----	----	----

"----" indicates that the parameter should be set to 0.

6. Non-Cyclic Data Channel

The non-cyclic data channel provides the controlling PLC with a method of reading from or writing to any parameter within the drive. This channel can be used for single infrequent data transfers, or uploading and downloading parameter sets for a particular node. This would allow the PLC program detect new or replacement nodes, and download the required parameter set.

6.1. Supported Non-Cyclic Commands

The UD70 with Modbus Plus interface cannot issue these commands over a Modbus Plus network, but it will respond to another device on the network that has this capability, typically a PLC or PC.

All drive parameters can be considered as registers on the network, with addresses 40MMPP, or 4MMPP on some PLCs. MM represents the menu number while PP represents the parameter within the menu, so parameter #1.21 (digital speed reference 1) would be register 400121 (or 40121).

6.1.1. PRESET SINGLE REGISTERS

This command allows a single parameter to be written in the drive.

6.1.2. PRESET MULTIPLE REGISTERS

The PRESET MULTIPLE REGEISTERS command allows a PLC to write data values to a block of up to 20 consecutive parameters within a single menu. For example, parameters #18.11 through #18.30 can be written to using a single PRESET MULTIPLE REGISTERS command.

6.1.3. READ MULTIPLE REGISTERS

The READ MULTIPLE REGEISTERS command allows a PLC to read data values from a block of up to 20 consecutive parameters within a single menu. For example, parameters #18.01 through #18.20 can be read using a single READ MULTIPLE REGISTERS command.

NOTE

The maximum number of registers that can be written to or read from a UD70 with Modbus Plus interface on a single PRESET MULTIPLE command is limited to 20. This prevents any overload problems with trying to read/write parameter values between the UD70 and Unidrive.

7. Diagnostics

The information from the parameters described below should always be noted before contacting Control Techniques for technical support.

NOTE

There have been no revisions of hardware or firmware in the UD70 with Modbus Plus interface for Unidrive. All new features described in this manual can be added to existing modules by downloading the appropriate system file.

7.1. Fieldbus Code

Unidrive #20.14 (Read Only)

The fieldbus code identifies the hardware level in the option module. This information is vital when trying to determine what upgrades can be performed on older modules.

The identification of the high-speed communications option module can be read from #20.14 on the Unidrive display. (The code is also available as #89.04.) This number is shown in the form XYZ, where X is the fieldbus type, Y is the fieldbus flavour, and Z is the hardware revision level.

Code	Fieldbus Type	Fieldbus Flavour	Hardware Revision
400	4 (Modbus Plus)	0	0 (UD76A Issue A and UD76B Issue 1)

NOTE

System file V2.07.05 or later must be installed in the UD70 to indicate the full fieldbus code.

7.2. System File Version

Unidrive #17.02 (Read Only)

The system file installed in the UD70 must be the correct file for the communications option installed. The system file for the UD70 with Modbus Plus interface is "MBPLUS.SYS".

The system file that must be installed can depend on the level of hardware and firmware in the module. In general, new system files are backward compatible with older versions of firmware and hardware, but there may be some limitations when upgrading older modules. The system file version can be read from parameter #17.02 on the Unidrive.

Firmware	Hardware Revision	System File	Comments
N/A	0	V2.07.05 or later	

7.3. Node Address

Unidrive #20.01 (Read Only)

Every Modbus Plus node must be assigned a unique node address. If two or more nodes have the same address, this will cause a conflict when the master attempts to initialise the network. Ideally, the node address should be configured on each node BEFORE any attempt is made to connect it to the network.

The node address is set by configuring the DIP switches on the Modbus Plus module. #20.01 indicates the current setting of these DIP switches.

7.4. Network Data Rate

Unidrive N/A

The data rate for a Modbus Plus network is fixed at 1.0 Mbits/sec.

7.5. Network Status

Unidrive #20.50

The status of the network is also displayed in #20.50. A positive value (or 0) indicates that the Modbus Plus interface is functioning correctly, and the display indicates the number of register transfers (IN and OUT) being transmitted and received every second.

A value of -1 indicates a network error, possibly caused by a broken wire, bad connection or duplicate node address.

A value of -2 indicates that the UD70 was unable to initialise the Modbus Plus interface hardware. An internal hardware failure is a possible cause of this error, and the module should be replaced and returned to Control Techniques.

#20.50	Indication	Description
>0	Network OK	Indicates the number of data registers being transferred (input and output) per second.
0	Network OK	The node is exchanging the token with the rest of the network, but no data is being transferred to or from the node.
-1	Network Failure	Token not being received, node is the only station on the network, or there is an internal hardware failure.
-2	Duplicate Node Address	Another node on the network has an identical node address.

7.6. Trip Action on Network Loss

There is no automatic network loss trip on Modbus Plus. DPL code must be included to in the UD70 to force the drive to trip in the event of the network being lost.

When the UD70 is reset, the Modbus Plus interface takes approximately 8 seconds to re-initialise and start communicating with the network. During this period, the network loss trip must be disabled to prevent the UD70 from tripping the drive before communications has been re-established.

```
INITIAL {
; disable network loss trip for 8 secs after INITIAL task
init_time% = TIME + 8000
trip_enable% = 0
o_stat% = 0
}

ENCODER {
; if 8 secs delay has elapsed, enabling network loss trip
IF TIME > init_time% THEN trip_enable% = 1

; if network loss trip is enabled
IF trip_enable% = 1 THEN

    n_stat% = #20.50      ; check current status

    ; if status has changed from healthy to unhealthy,
    ; trip drive on tr60
    IF n_stat% < o_stat% AND n_stat% < 0 THEN #10.38 = 60

    o_stat% = n_stat%    ; store current status
ENDIF
}
```

If the Unidrive trips, then provided it is not due to a Modbus Plus network or internal UD70 error, the node will continue to operate on the network.

If a node is disconnected from the network but the network is not physically broken, the rest of the network will continue to operate. A short reconfiguration period may be seen where no data is transferred, but the network will subsequently continue operation without the disconnected node.

7.7. Other Unidrive Trip Codes

If certain errors occur, the Unidrive will trip and show the trip code in the upper window.

Trip Code	Error
tr52	This code indicates that the trip originated from the setting of bit 4 in the control Word.
tr56	The UD70 does not contain the correct operating system. Download the system file "MBPLUS.SYS".
tr57	An illegal operating system call has been made. For example, WRNET. This is a CTNet command, and is not available with Modbus Plus.

To reset the Unidrive using the Modbus Plus network, write a value of 100 to #10.38 using the non-cyclic data channel. (Refer to Unidrive Manual.)

8. Appendix

8.1. Modbus Plus Network Operation

Modbus Plus uses a "token rotation" system to prevent two or more nodes from attempting to transmit at the same time, and corrupting data on the bus. With a token rotation system, a node can only transmit data over the bus when it is in possession of the token, so preventing data collisions.

The token is a "software token", and is passed from node to node in the form of a message. When a node is in possession of the token, it has full control of the network, and can transmit a single data message. The token is then passed on to the drive with the next highest node address on the network, and so on. If there is no node with a higher address, the token is passed to the drive with the lowest address, and the token rotation sequence starts again. This process is happening continuously, even if no actual data is being transferred.

As the token message is transmitted once by every node on every complete token rotation, the Modbus Plus protocol and hardware allow data bytes to be included in the token message. This increases the time taken to transmit the token message, but does mean that the data bytes are effectively broadcast across the whole network. Every Modbus Plus node will receive the token message and extract the data bytes. This feature is known as "Global Data" and allows fast update times over the network, since every node will have been updated with the global data from every other node on the network.

8.2. Error Detection

The Modbus Plus protocol incorporates error detection automatically into each message. CRC codes are calculated and attached to each message by the Modbus Plus hardware when a message is transmitted. A receiving node will re-calculate the CRC code on the received message, and check it against the CRC code attached to the message. If they match, the message is deemed valid, and processed; otherwise the message is discarded.

Error correction is not provided, as the lifetime of data in industrial applications using real-time communications systems is very short, and transmitting error correction data would only consume additional network bandwidth.