

User Guide

UD78

Servo
large option module
for Unidrive

Part Number: 0460 - 0086

Issue Number: 2

General Information

The manufacturer accepts no liability for any consequences resulting from inappropriate, negligent or incorrect installation or adjustment of the operating parameters of the equipment or from mismatching the Drive with the motor.

This option module is intended for use only with Control Techniques Unidrive products. Any other use invalidates the warranty and may cause a safety hazard.

The contents of this Guide are believed to be correct at the time of printing. In the interests of a commitment to a policy of continuous development and improvement, the manufacturer reserves the right to change the specification of the product or its performance, or the contents of this Guide, without notice.

All rights reserved. No part of this Guide may be reproduced or transmitted in any form or by any means, electrical or mechanical including photocopying, recording or by any information storage or retrieval system, without permission in writing from the publisher.

Use within the European Union, etc

The following information applies where the end use of the Drive is within the European Union, the European Economic Area, or other regions which have implemented Directives of the European Council or equivalent measures.

The Drive, together with its associated option modules, complies with the Low Voltage Directive 73/23/EEC.

The installer is responsible for ensuring that the equipment into which the Drive is incorporated complies with all relevant Directives.

The complete equipment must comply with the EMC Directive 89/336/EEC.

If the Drive is incorporated into a machine, the manufacturer is responsible for ensuring that the machine complies with the Machinery Directive 89/392/EEC. In particular, the electrical equipment should generally comply with European Harmonised standard EN60204-1.

Copyright © January 2002 Control Techniques Drives Ltd

Issue Code: 78nu2

Contents

Chapter		
1	Introduction	1
1.1	Main features of the UD78	1
2	Safety Information	3
3	Installing the UD78	6
4	Making Connections	8
4.1	Locations of the connectors	8
4.2	<i>SK1 Precision analog input</i> connector	9
	Functions of the terminals	9
	Specification	10
4.3	<i>SK2 Back-up DC supply input</i> connector	11
	Functions of the terminals	11
	Specification	11
	Operation	12
4.4	<i>PL1 Serial communications</i> connector	13
	Functions of the terminals	13
	Specification	13
	Serial communications modes	14
	Ground connection	16
	Routing the serial communications cable	17
	Terminating the cable	17
	Operation	17
5	Related Parameters	18
5.1	Introduction	18
5.2	<i>Precision analog input</i> parameters	19
5.3	<i>Back-up DC supply</i> parameter	22
5.4	<i>Serial communications</i> parameters	21

Appendix

A	Serial Comms. ANSI Message Formats	A-1
A.1	Fundamentals of data transmission	A-1
A.2	Reading a parameter value	A-4
A.3	Re-reading a parameter value	A-5
A.4	Writing a parameter value	A-5
A.5	Re-writing a parameter value	A-6
A.6	Calculating the block checksum (BCC)	A-6
B	Setting up the Drive using UniSoft	B-1

1 Introduction

1.1 Main features of the UD78

Note

The UD78 can be used only with Drives equipped with version 3 (or later) software. (Parameter 0.50 indicates the software version.)

Main functions

The UD78 *large option module* is an interface module for installation in a Unidrive and has the following functions:

- Precision analog input
- EIA RS485, 4-wire or 2-wire, serial communications interface (fully opto-isolated)
- Back-up +24V DC supply input for keeping the control circuits of the Drive (and the UD78) operating when the AC supply to the Drive is disconnected.

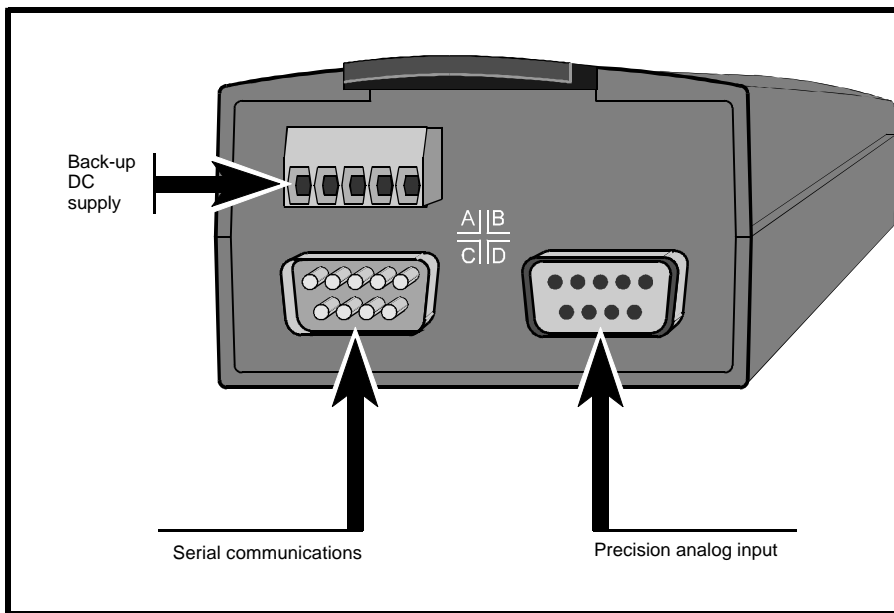

Figure 1 The functions of the UD78 connectors

- Precision analog input** The precision analog input replaces terminals 5 and 6 *Analog input 1* in the Drive. Terminals 5 and 6 can then not be used for any purpose. The parameters associated with Analog input 1 now relate to the precision input.
- Serial comms. interface** The serial communications interface allows the following:
- The Drive to be controlled and monitored remotely by a system controller
 - The Drive to control or monitor another Drive
- Installation** The UD78 must be fitted in the *large option module* bay of the Unidrive. Precision analog input and serial communications connections are made by 9-way D-type connectors. The external Back-up DC supply connections are made by a pluggable 5-way screw-terminal block.

2 Safety Information



2.1

Warnings, Cautions and Notes

A **Warning** contains information which is essential for avoiding a safety hazard.

A **Caution** contains information which is necessary for avoiding a risk of damage to the product or other equipment.

A **Note** contains information which helps to ensure correct operation of the product.

2.2

Electrical safety – general warning

The voltages used in the Drive can cause severe electric shock and/or burns, and could be lethal. Extreme care is necessary at all times when working with or adjacent to the Drive.

Specific warnings are given at the relevant places in this User Guide.

The installation must comply with all relevant safety legislation in the country of use.

The Drive contains capacitors that remain charged to a potentially lethal voltage after the AC supply has been disconnected. If the Drive has been energized, the AC supply must be isolated at least ten minutes before work may continue.

2.3

System design

The Drive is intended as a component for professional incorporation into complete equipment or systems. If installed incorrectly the Drive may present a safety hazard. The Drive uses high voltages and currents, carries a high level of stored electrical energy, and is used to control mechanical equipment which can cause injury.

Close attention is required to the electrical installation and the system-design to avoid hazards either in normal operation or in the event of equipment malfunction. System-design, installation, commissioning and maintenance must be carried out by personnel who have the necessary training and experience. They must read this safety information and this User Guide carefully.

To ensure mechanical safety, additional safety devices such as electro-mechanical interlocks may be required. The Drive must not be used in a safety-critical application without additional high-integrity protection against hazards arising from a malfunction.

2.4 Environmental limits

Instructions in the *Unidrive Installation Guide* regarding transport, storage, installation and use of Drives must be complied with, including the specified environmental limits. Drives must not be subjected to excessive physical force.

2.5 Compliance with regulations

The installer is responsible for complying with all relevant regulations, such as national wiring regulations, accident prevention regulations and electromagnetic compatibility (EMC) regulations. Particular attention must be given to the cross-sectional areas of conductors, the selection of fuses or other protection, and protective earth (ground) connections.

The *Unidrive Installation Guide* contains instructions for achieving compliance with specific EMC standards.

Within the European Union, all machinery in which this product is used must comply with the following directives:

89/392/EEC: Safety of Machinery

89/336/EEC: Electromagnetic Compatibility

2.6 Safety of personnel

The STOP function of the Drive does not remove dangerous voltages from the output of the Drive or from any external option unit.

The Stop and Start controls or electrical inputs of the Drive should not be relied upon to ensure safety of personnel. If a safety hazard could exist from unexpected starting of the Drive, an interlock that electrically isolates the Drive from the AC supply should be installed to prevent the motor being inadvertently started.

Careful consideration must be given to the functions of the Drive which might result in a hazard, either through their intended functions (eg. Auto-start) or through incorrect operation due to a fault or trip (eg. stop/start, forward/reverse, maximum speed).

Under certain conditions, the Drive can suddenly discontinue control of the motor. If the load on the motor could cause the motor speed to be increased (eg. hoists and cranes), a separate method of braking and stopping the motor should be used (eg. a mechanical brake).

Before connecting the AC supply to the Drive, it is important that you understand the operating controls and their operation. If in doubt, do not adjust the Drive. Damage may occur, or lives put at risk. Carefully follow the instructions in this User Guide.

Before making adjustments to the Drive, ensure all personnel in the area are warned. Make notes of all adjustments that are made.

2.7 Risk analysis

In any application where a malfunction of the Drive could lead to damage, loss of life or injury, a risk analysis must be carried out, and where necessary, further measures taken to reduce the risk. This would normally be an appropriate form of independent safety back-up system using simple electro-mechanical components.

2.8 Signal connections

The control circuits are isolated from the power circuits in the Drive by basic insulation only, as specified in IEC664–1. The installer must ensure that the external control circuits are insulated from human contact by at least one layer of insulation rated for use at the AC supply voltage.

If the control circuits are to be connected to other circuits classified as Safety Extra Low Voltage (SELV) (eg. to a personal computer), an additional isolating barrier must be included in order to maintain the SELV classification.

2.9 Adjusting parameters

Some parameters have a profound effect on the operation of the Drive. They must not be altered without careful consideration of the impact on the controlled system. Measures must be taken to prevent unwanted changes due to error or tampering.

3 Installing the UD78



Warning

Before using the following procedure, refer to the Warnings at the beginning of Chapter 2 *Installing the Drive in the Unidrive Installation Guide*.

- 1 Before installing the UD78 in the Unidrive, ensure the AC supply has been disconnected from the Drive for at least 10 minutes.
- 2 Check that the exterior of the UD78 is not damaged, and that the multi-way connector is free from dirt and debris. Do not install a damaged or dirty UD78 in the Drive.
- 3 Remove the terminal cover from the Drive (for removal instructions, see *Installing the Drive and RFI filter* in Chapter 2 of the *Unidrive Installation Guide*).
- 4 Push the UD78 into the cavity immediately behind the keypad and display until the UD78 locks in place.
- 5 Re-fit the terminal cover to the Drive.
- 6 Connect the AC supply to the Drive.
- 7 Set parameter **.00** at **149** to unlock security.
- 8 Check that parameter **7.31** is set at **1** to indicate that the module is fitted.
- 9 If the check in step 8 fails, perform the following:
 - Remove the AC supply from the Drive.
 - Wait at least 10 minutes.
 - Remove the terminal cover.
 - Check that the UD78 is fully inserted.
 - Replace the terminal cover.
 - Re-apply the AC supply.
 - Check again that parameter **7.31** is set at **1**.

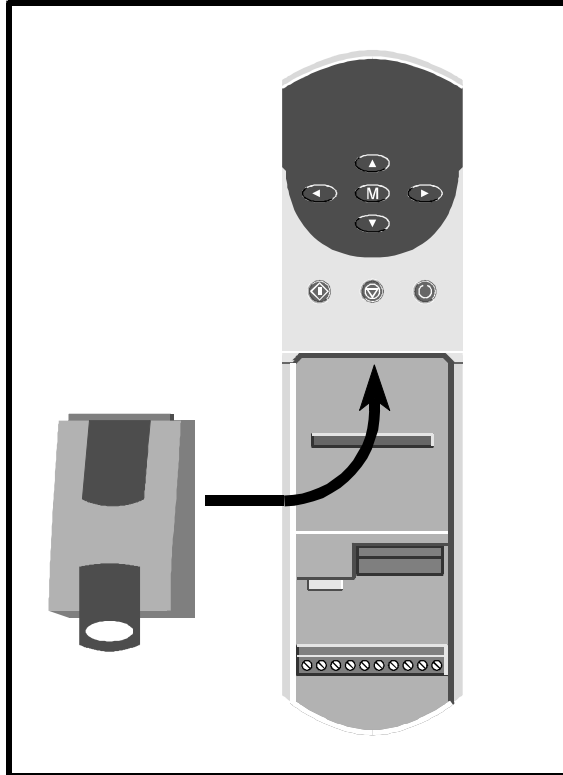

Figure 2 *Installing the UD78 in the Unidrive*

Do not remove the UD78 from the Drive when either the AC supply or a DC back-up supply is applied to the Drive. If the UD78 is removed when the Drive is powered-up, the Drive will trip; the display will indicate **ANI.diS**.

If the UD78 is deliberately removed, it may be necessary to re-adjust the parameters related to analog input 1, since they will now relate to terminals 5 and 6.

4 Making Connections



Warning

The control circuits are isolated from the power circuits in the Drive by basic insulation only, as specified in IEC664-1. The installer must ensure that the external control circuits are insulated from human contact by at least one layer of insulation rated for use at the AC supply voltage.

If the control circuits are to be connected to other circuits classified as Safety Extra Low Voltage (SELV) (eg. to a personal computer), an additional isolating barrier must be included in order to maintain the SELV classification.

4.1 Locations of the connectors

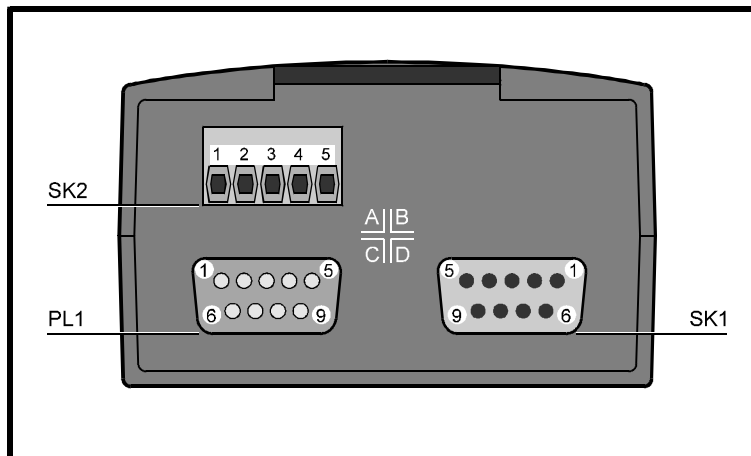

Figure 3 Locations of the connectors on the UD78

4.2 SK1
Precision analog input connector

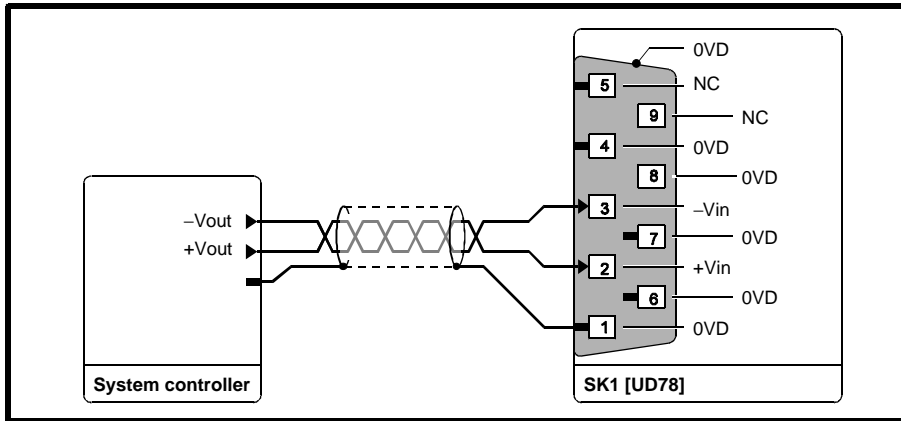

Figure 4 Connections to the precision analog input

Functions of the terminals

Terminal	Name	Function
1	OVD	0V
2	+Vin	Reference input +
3	-Vin	Reference input -
4	OVD	0V
5	NC	Not connected
6	OVD	0V
7	OVD	0V
8	OVD	0V
9	NC	Not connected
Shell	OVD	0V

Specification

Input type	Differential
Mode	Bipolar voltage
Full-scale differential input voltage	$\pm 9.8V \pm 1\%$ (see parameter 7.25)
Absolute maximum differential input voltage	$\pm 30V$
Absolute maximum input voltage	$\pm 50V$ relative to OVD
Common mode rejection ratio	95dB
Input resistance	20k Ω
Full-scale asymmetry	$\pm 0.1\%$ maximum
Offset error	$< 150\mu V$
Dead-band at zero input	$< 150\mu V$
Zero-crossing error	$< 150\mu V$
Linearity error	$\pm 0.1\%$ of full scale
Input-filter time-constant	10 μs
Resolution	Open-loop: 12-bit plus sign Closed-loop: ∞ (pulses are accumulated)
Sample period	(See below)

Operating mode	Destination parameter for the analog input	PWM switching frequency (kHz)	Sample period
Closed-loop	1.36 <i>Analog reference 1</i>	3, 6, 12	345 μs
	1.37 <i>Analog reference 2</i>	4, 5, 9	460 μs
	3.19 <i>Hard speed reference</i> 4.08 <i>Torque reference</i>		
Open-loop	1.36 <i>Analog reference 1</i>	3, 6, 12	1.38ms
	1.37 <i>Analog reference 2</i>	4, 5, 9	1.84ms
	4.08 <i>Torque reference</i>		
	All other parameters	3, 6, 12	5.5ms
		4, 5, 9	7.4ms

4.3 SK2 Back-up DC supply input connector

Functions of the terminals

Terminal	Name	Function
1	OVD	0V
2	+DC	+24 Volts supply input
3	NC	Not connected
4	OVD	0V
5	+DC	+24 Volts supply input

Terminals 2 and 5 are internally connected to allow chain connection for up to three Drives. When four or more Drives are connected, a star wiring configuration should be used.

Specification

Required supply voltage (including ripple)	22.8V ~ 26.4V
Maximum ripple at 100Hz	1V RMS
Absolute maximum voltage	+50V
Absolute maximum reverse voltage	-30V
Continuous current when the AC supply is disconnected from the Drive	<1A
Continuous current when the AC supply is connected to the Drive	20mA
Temperature limits	(See below)

Drive powered only by the back-up DC supply	Up to 30°C (86°F)	The Drive can be powered indefinitely
	Up to 40°C (104°F)	The Drive can be powered for 15 minutes maximum
Drive powered by the AC supply	Up to 40°C (104°F)	The Drive can be powered indefinitely
	Up to 50°C (122°F)	Refer to the <i>Unidrive Installation Guide</i>

Operation

For automatic operation of the back-up DC supply, this supply should be connected continuously.

The following table shows the results of a combination of supply conditions. A 400VAC supply is considered to be removed when it is below approximately 230V RMS.

AC supply	Back-up DC supply	Resulting effect
Present	Present or absent	Control circuits and power stages operate (Drive fully operational, including the precision analog input)
Absent	Present	If the AC supply is present, then removed, parameters that are saved at power-down are saved Only the control circuits operate The Drive cannot power a motor The Drive displays LOPS The Drive can be programmed either manually or via serial communications, but parameter values cannot be saved Model sizes 1 and 2: Heatsink fan operates Model sizes 3 and 4: Heatsink fans do not operate

Power-up delays

The following delays occur:

AC supply disconnected Back-up DC supply <i>being</i> connected	5 second delay for Drive display and serial communications to become active
Back-up DC supply <i>already</i> connected AC supply <i>being</i> connected	5 second delay before the Drive can be enabled

Note

Stator resistance test (open-loop only)

If parameter **5.14 (0.07)** is set at **Ur_1** for the Drive to perform a stator resistance test at power-up, and the AC supply is disconnected, the Drive will trip if the Back-up DC supply is connected. The Drive will display trip code **rS**, indicating failure to perform the stator resistance test.

To prevent this occurring, set parameter **5.14 (0.07)** at one of the following, and refer to *Voltage boost* in Chapter 4 *Menu 0 parameters* in the *Unidrive User Guide*:

Ur_S, Ur, Fd

4.4 PL1 Serial communications connector

Functions of the terminals

Terminal	Name	Function
1	OVSC	OV
2	TX\	Transmit output (inverted)
3	RX\	Receive input (inverted)
4	TXTERM	TX termination-resistor connection
5	RXTERM	RX termination-resistor connection
6	TX	Transmit output
7	RX	Receive input
8	TX\TERM	TX\ termination-resistor connection
9	RX\TERM	RX\ termination-resistor connection
Shell	OVSC	OV

Specification

RX (input)	2 unit-loads (EIA RS485)
TX (output)	2 unit-loads (EIA RS485)
2-wire (Transceiver mode)	4 unit-loads (EIA RS485)
Termination resistance	120Ω ±5% (no series capacitor)

In accordance with the EIA RS485 specification, the total load on a line must not exceed 32 unit-loads. Each transmitter and receiver of the UD78 loads the line by two unit-loads (in two-wire mode, each UD78 loads the line by four unit-loads). This allows the following to be operated:

- 15 units in 4-wire mode
- 7 units in 2-wire mode

When line repeaters are used, up to 81 Control Techniques devices can be operated. In this case the devices must be arranged in up to nine groups of nine. A particular group or groups can be given commands without affecting other devices or groups of devices.

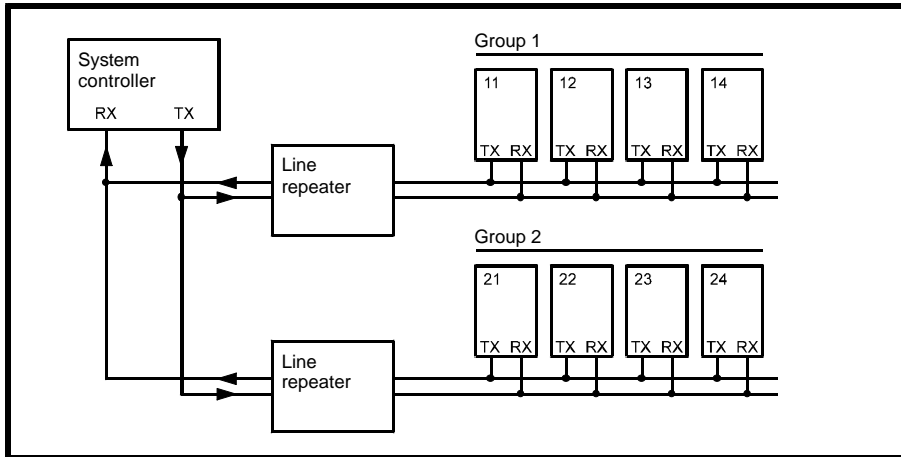

Figure 5 RS485 multi-drop link having two groups of four units

Serial communications modes

The serial communications interface can be set up for operation in the following modes:

2-wire ANSI	Half-duplex communications (transceiver mode)
4-wire ANSI	Half-duplex communications, independent RX and TX channels
Output	The Drive is to control another Drive (CT protocol)
Input	The Drive is to be controlled by another Drive (CT protocol)

Make connections as shown in Figure 6, 7 or 8 as required. If the Drive is to be set up using Unisoft on a PC, see Appendix B *Setting up the Drive using Unisoft*.

Four-wire ANSI

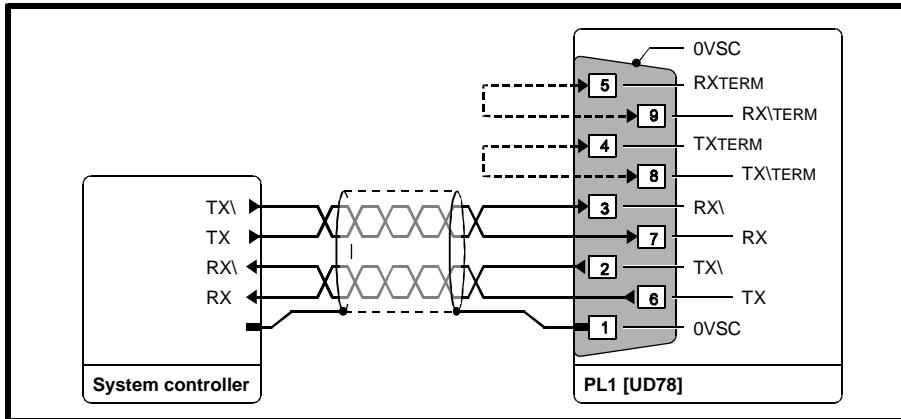

Figure 6 4-wire serial communications connections

Ensure parameter **11.24 Serial comms. mode selector** is set at **ANSI 4 (1)** (default setting).

Two-wire ANSI

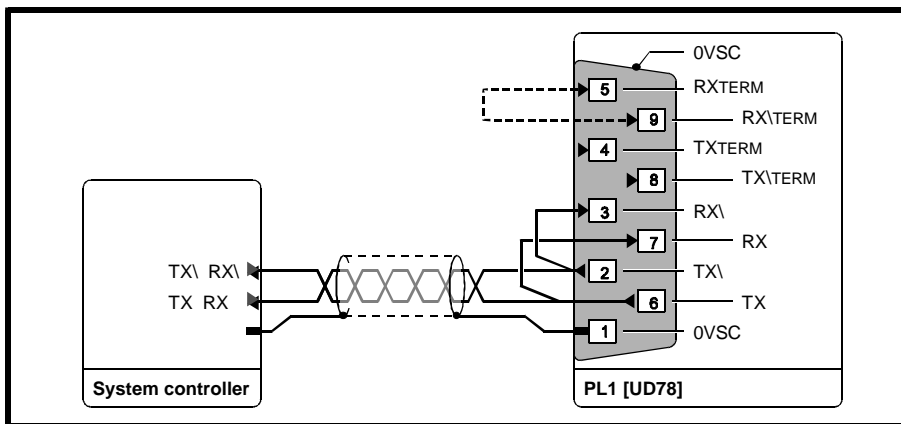

Figure 7 2-wire (transceiver mode) serial communications connections

Set parameter **11.24 Serial comms. mode selector** at **ANSI 2 (0)**.

Output and Input modes

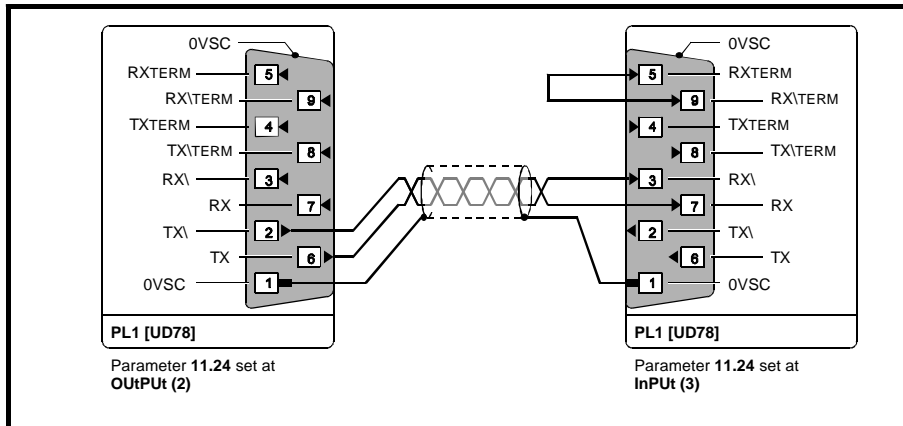

Figure 8 *Serial communications connections for the Input and Output modes*

Data is transferred at a rate of at least 140Hz. The protocol and range of baud rates allow communications with the Mentor II and CDE models, as well as other Unidrive models.

Only the value of a variable parameter can be transmitted and received. Bit parameters are excluded.

Set parameter **11.24** *Serial comms. mode selector* as follows:

Output mode: **OutPUt** (2)

Input mode: **InPUt** (3)

Output mode

The value of a variable parameter selected by parameter **11.27** *Serial comms. source selector* is sent (after scaling by **11.28** *Serial comms. parameter scaling*) to the serial communications port for transmission.

If the Drive trips, the value **0** is transmitted.

Input mode

The value received by the serial communications port is applied (after scaling by **11.28** *Serial comms. parameter scaling*) to an unprotected variable parameter selected by parameter **11.27** *Serial comms. destination selector*.

If communications fail, the Drive will trip; the display will indicate **SCL**.

Ground connection

In addition to each end of the cable shield being connected to 0V, it can be connected by a single path to a 'clean' ground.

Routing the serial communications cable

A data communications cable should not run parallel to any power cables, especially ones that connect Drives to motors. If parallel runs are unavoidable, ensure a minimum spacing of 300mm (12 in) between the communications cable and the power cable.

Where cables are required to cross, they should be at right-angles to each other in order to minimize coupling.

The maximum cable length for an EIA RS485 link is 1200 metres (4000 feet).

Terminating the cable

It is recommended that UD78 modules, the system controller and other equipment on a serial communications link are chain connected. The link must be terminated at the unit that is at the end of the link. If this unit is a UD78, the RX line can be terminated by linking terminals 5 and 9; the TX line by linking terminals 4 and 8.

Note

When 2-wire mode (transceiver) is used, link terminals 5 and 9 as shown in Figure 7. Do not link terminals 4 and 8.

Operation

Internal bias resistors ensure that logic 1 is detected when the RX lines are not driven.

The following parameters apply to the serial communications port.

Parameter		Applies to...
11.23	Serial comms. address	ANSI 2 and ANSI 4 modes
11.24	Serial comms. mode <i>selector</i>	All serial comms. modes
11.25	Serial comms. baud rate	ANSI 2 and ANSI 4 modes
11.26	Serial comms. 2-wire mode delay	ANSI 2 mode
11.27	Serial comms. source/destination <i>selector</i>	Input and Output modes only
11.28	Serial comms. parameter scaling	Input and Output modes only

See *Serial communications parameters* in Chapter 5 *Related parameters* and to Appendix A *Serial communications message formats*.

5 Related Parameters

5.1 Introduction

The parameters listed in this chapter are used for programming and monitoring the UD78 when it is fitted in a Drive. Refer to the *Unidrive User Guide* for programming instructions.



Warning

Before attempting to adjust any parameters, refer to the Warnings and Notes at the beginning of Chapter 3 *Setting up the Drive* in the *Unidrive User Guide*.

Key

Type of parameter



RO Read-only



RW Read-write

...selector Select from a number of settings

...enable Make or allow a function to operate

...indicator The value can only be read

Limitations of use

R The Drive must be reset for a new value to take effect.

P Protected parameter; the parameter cannot be used as the destination parameter for a programmable input.

Range

Bi Variable parameter having bipolar value range.

Uni Variable parameter having unipolar value range.

Bit Bit parameter

Symbols

⇄ Default value

⇅ Range of values

~ Indicates a range of values
(in the case of bit parameters, ~ indicates *or*).

5.2 Precision analog input parameters

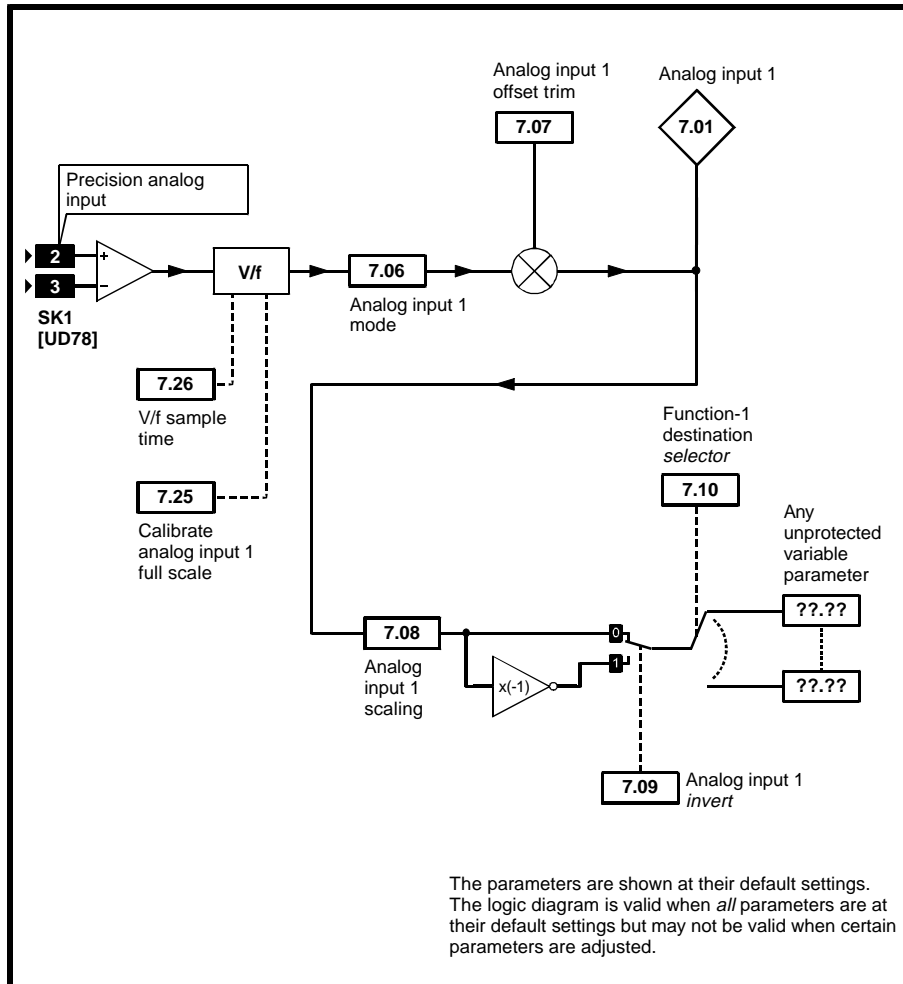

Figure 9 Logic diagram for the precision analog input

7.01 Analog input 1 indicator

±100	↔		%	RO	Bi			P
------	---	--	---	----	----	--	--	---

7.01 indicates the value of the precision analog input after offset trim has been applied by parameter **7.07 Analog input 1 offset trim**. The indicated value is a percentage of the full-scale amplitude (see parameter **7.25 Calibrate analog input 1 full-scale enable**).

7.06 Analog input 1 mode selector

VOLt	↔	VOLt		RW	Txt			P
------	---	------	--	----	-----	--	--	---

The setting of **7.06** cannot be changed.

7.07 Analog input 1 offset trim

±10.000	↔	0	%	RW	Bi			P
---------	---	---	---	----	----	--	--	---

If an unwanted offset exists in the analog reference signal, adjust **7.07** to cause **7.01 Analog input 1 indicator** to indicate zero.

7.08 Analog input 1 scaling

0 ~ 4.000	↔	1		RW	Uni			
-----------	---	---	--	----	-----	--	--	--

Set **7.08** at the required value to alter the scaling of the analog reference. The scaling takes place after full-scale calibration (see parameter **7.25 Calibrate analog input 1 full-scale enable**). **7.01 Analog input 1 indicator** is not affected by the setting of **7.08**.

7.09 Analog input 1 invert

0 ~ 1	↔	0		RW	Bit			
-------	---	---	--	----	-----	--	--	--

Set **7.09** at 1 to invert the value of the analog input.

7.10 Analog input 1 destination selector

0.00 ~ 20.50	↔	1.36	Menu. parameter	RW	Uni		R	P
--------------	---	------	--------------------	----	-----	--	---	---

The default setting of **7.10** assigns terminals 2 and 3 of SK1 to **1.36 Analog reference 1**. If required, use **7.10** to change the function of the precision analog input by entering the required **menu.parameter** number (eg. **4.08** for torque reference).

Only a variable parameter that is not protected can be specified. If any other type of parameter is specified, the input is not assigned to any parameter.



To make the new setting take effect, press

7.25 Calibrate analog input 1 full-scale enable

⇅	0 ~ 1	⇄	0		RW	Bit			
---	-------	---	---	--	----	-----	--	--	--

By default, the input is calibrated so that 9.8V sets **7.01** at 100%. Use the following procedure to change the full-scale value:

- 1 Apply the required full-scale value to terminals 2 and 3, as follows:
 - If the applied value is greater than 2.5V, it will become the new full-scale value
 - If the applied value is less than 1.5V, the new full-scale value will be the default value (9.8V)

- 2 Set **7.25** at 1.

The input scaling automatically changes according to the applied value (see step 1). This new value will set **7.01** at 100% and will remain effective until this procedure is next performed.

The new setting is saved at power-down.

7.26 V/f sample time

⇅	CL> 0 ~ 5.0	⇄	4	ms	RW	Uni			
---	-------------	---	---	----	----	-----	--	--	--

Closed-loop only

When **7.10** is set at **1.36** (default), **1.37**, or **3.19**, if required set **7.26** for the best compromise between low-speed operation and dynamic response. Low values give good dynamic response but noisy operation at low speeds. High values give smooth low-speed operation but a poorer dynamic response.

7.31 UD78 large option module fitted indicator

⇅	0 ~ 1	⇄			RO	Bit			P
---	-------	---	--	--	----	-----	--	--	---

7.31 is set at 1 when a UD78 module is fitted in the Drive.

5.3 *Back-up DC supply* parameter

10.41 Back-up DC supply active

⇅	0 - 1	⇒			RO	Bit			P
---	-------	---	--	--	----	-----	--	--	---

10.41	Indicates...
0	AC supply connected Control circuits and power stages operate (Drive fully operating)
1	AC supply disconnected, back-up DC supply active Only the control circuits operate The Drive cannot power a motor The Drive displays LOPS The Drive can be programmed either manually or via serial communications, but parameter values cannot be saved Model sizes 1 and 2: Heatsink fan operates Model sizes 3 and 4: Heatsink fans do not operate

5.4 *Serial communications* parameters

11.23 Serial comms. address

⇅	0 - 9.9	⇒	1.1	group.unit	RW	Uni			P
---	---------	---	-----	------------	----	-----	--	--	---

Enter the required address (group number and unit number) in **11.23**. The address cannot contain **0** (eg. addresses **01, 10, 20, 30** are not permissible). Each UD78 on a serial communications network must have a unique address. Up to nine groups can be created, and up to nine units can be assigned to a group. (See Appendix A *Serial communications message formats*.)

11.24 Serial comms. mode selector

⚙ (See below)	⇄	ANSI 4 (1)		RW	Txt		R	P
---------------	---	------------	--	----	-----	--	---	---

Set **11.24** as follows:

11.24	Mode	Special parameter
ANSI 2 (0)	2-wire half-duplex (transceiver mode)	11.26 <i>Serial comms. 2-wire mode delay</i>
ANSI 4 (1)	4-wire half-duplex, independent RX and TX channels	
OutPut (2)	The Drive can control another Drive	11.27 <i>Serial comms. source selector</i>
InPut (3)	The Drive can be controlled by another Drive	11.27 <i>Serial comms. destination selector</i>

See *PL1 Serial communications connector* in Chapter 4 *Making Connections*.

11.25 Serial comms. baud rate

⚙	4800 (0) 9600 (1) 19200 (2)	⇄	4800	baud	RW	Txt			P
---	-----------------------------------	---	------	------	----	-----	--	--	---

Applicable only in ANSI 2 and ANSI 4 modes.

11.26 Serial comms. 2-wire mode delay

⚙	0 ~ 255	⇄	0	ms	RW	Uni			
---	---------	---	---	----	----	-----	--	--	--

When **11.24** is set at **ANSI 2** for 2-wire (transceiver) operation, it is possible for the UD78 to reply to an interrogation from the system controller before the system controller returns from transmit to receive mode. If this occurs, data will be lost.

Use **11.26** to set sufficient delay before the UD78 replies to an interrogation.

11.27 Serial comms. source/destination selector

⇅	0.00 ~ 20.50	⇄	0	Menu. parameter	RW	Uni		R	P
---	--------------	---	---	--------------------	----	-----	--	---	---

Use **11.27** to select the following..

Output mode: Required source parameter

Input mode: Required destination parameter

Output mode

Only a variable parameter can be specified.

If any other type of parameter is specified, no value is transmitted.

Input mode

Only a variable parameter that is not protected can be specified

If any other type of parameter is specified, the input is not assigned to any parameter.

Both modes

To make the new setting take effect, press



11.28 Serial comms. parameter scaling

⇅	0 ~ 4.000	⇄	1		RW	Uni			
---	-----------	---	---	--	----	-----	--	--	--

Input and output modes

If required, use **11.28** to scale the value being transmitted or received.

A Serial Communications

ANSI Message Formats

A.1 Fundamentals of data transmission

Data frame

Data is transmitted at a fixed speed or baud rate in the form of a character. A character comprises seven bits.

In order for a receiver to recognize valid data, a frame is placed around each character. This frame contains a start bit, a stop bit, and a parity bit. Without this frame, the receiver will be unable to synchronize itself with the transmitted data.

The frame used in the ANSI protocol is as follows:

Low ASCII character byte									
1st hex character					2nd hex character				
Start bit	7 data bits							Parity bit	Stop bit
0	LSB						MSB		1

This is known as a 10-bit frame, since there are 10 bits transmitted in total. The format is described as follows:

1 start bit, 7 data bits, even parity, 1 stop bit.

lsb refers to the least significant bit (ie. bit 0)

msb refers to the most significant bit (bit 6)

The *Parity bit* is used by the receiver to check the integrity of the data it has received (even parity is used)

The character set used is called the low ASCII set. The set comprises 128 characters decimally numbered from 0 to 127. The first 32 characters in the ASCII set (hex. 00 to 1F) are used to represent special codes. These are the *control* codes, each of which has a particular meaning (eg. start of text is called STX and is ASCII code 02.)

Control characters

Commands and requests are sent in message packets. Each message is started with a special control character, and may contain additional control characters. A list of all the control characters that can be used when a message is being sent or received is as follows:

Character	Meaning	ASCII code (decimal)	Keyed as...
EOT	Reset Instructs the Drive to prepare for a new message. Also indicates parameter does not exist.	04	Ctrl D
ENQ	Enquiry Used when interrogating the Drive.	05	Ctrl E
STX	Start of text Used to start a command.	02	Ctrl B
ETX	End of text Used at the end of a command.	03	Ctrl C
ACK	Acknowledge (message accepted)	06	Ctrl F
NAK	Negative acknowledge (message not understood)	21	Ctrl U
BS	Backspace (go to previous parameter)	08	Ctrl H

Addressing

Each Drive on an ANSI communications bus must be given a unique identity or *address* so that only the target Drive will respond to a command transmitted by the system controller. The address comprises the following two parts:

- Group address (first digit)
- Unit address (second digit)

Both the group address and unit address have a range of 1 to 9. A group or unit address of 0 is not allowed (addresses 01, 10, 20, etc. are invalid). The reason for this is that Drives can be grouped together (up to 9 units per group), and a message can be sent over the ANSI communications bus to all units of the group. To address a particular group, the unit address zero (0) is used. For example, to address all units of group 6, the full address will be 60.

An additional feature is that a message can be sent to all units of all groups simultaneously using the address 00. This address can be used to send a Start command to a group of Drives which are mechanically coupled together to drive a conveyer line. All the Drives will then start simultaneously.

Note

It is important to realize that when using group addressing, the Drives will not acknowledge the command. (If several Drives try to reply at the same time, they would cause meaningless data to appear on the serial communications bus.)

For security, the format of the transmitted address requires that each digit of the two-digit address is repeated: the address of Drive number 23 is sent as four characters, eg:

2 2 3 3

The serial address follows immediately after the first control character of the message (EOT).

Parameter identification

For transmission of their values, all parameters are identified by four digits representing the menu and the parameter number, but without the decimal point.

Example To send a message to menu 4, parameter 26, write **0426** (the leading zero must be included)

To send a message to menu 16, parameter 3, write **1603**.

Data field

Data to be sent or requested occupies the characters immediately after the parameter number. The minimum length of the data field within a message structure is two characters.

The data is normally expressed as a decimal numeric value; the first character of the data field (D1) can be only one of the following:

Space (32 dec.)

+

-

Block checksum (BCC)

In order to protect the system against messages that have become corrupted in transmission, all write messages and data responses are terminated by the block checksum character (BCC). See *Calculating the block checksum (BCC)* later in this appendix.

A.2 Reading a parameter value

To read the value of a parameter, the following message is sent:

Control	Address				Parameter				Control
EOT	GA	GA	UA	UA	M1	M2	P1	P2	ENQ

Where:

- GA = Group Address
- UA = Unit Address
- M1 M2 = Menu number
- P1 P2 = Parameter number

Note

No BCC character is sent in this message.

The Drive will reply with the following structure if the message is understood:

Control	Parameter				Data				Control	BCC
STX	M1	M2	P1	P2	D1	...	Dn	ETX	BCC	

Where:

- M1 M2 = Menu number
- P1 P2 = Parameter number
- D1...Dn = Data

First character:

- + or Space for positive values
- for negative values

- BCC = Block checksum

If a requested parameter does not exist, the Drive will reply with an **EOT** character (ASCII 04).

Example To read the value of parameter **1.21** in a Drive that is unit 2 of group 1, send:

Control	Address				Parameter				Control
STX	1	1	2	2	0	1	2	1	ENQ

The Drive replies as follows:

Control	Parameter				Data				Control	BCC			
STX	0	1	2	1	-	0	0	4	7	.	6	ETX	7

A.3 Re-reading a parameter value

Once a read message has been received and understood (ie. valid data was returned), to request the parameter value again, request the value of the next parameter, or the previous parameter, a single control code character may be sent. These control codes are as follows:

Control code	Function	Keyed as...
NAK	Return the value of the same parameter	Ctrl U
ACK	Read the next parameter	Ctrl F
BS	Read the previous parameter	Ctrl H

This facility can be used to save time when monitoring a parameter over a period of time.

A.4 Writing a parameter value

To write a value to a parameter, the message structure is comprised as follows:

Control	Address			Control	Parameter				Data			Control	BCC
EOT	GA	GA	UA UA	STX	M1	M2	P1	P2	D1	...	Dn	ETX	

Where:

GA = Group address

GU = Unit address

M1 M2 = Menu number

P1 P2 = Parameter number

D1...DN = Data

First character:

+ or Space for positive values

– for negative values

BCC = Block checksum

The data field can be of a variable length with the maximum length being dependent on the parameter being edited.

The Drive will respond with a single control character, as follows:

Control code	Meaning
ACK	Acknowledge — Message has been understood and implemented.
NAK	Message invalid Data is too long or out of range Parameter is invalid Parameter is read-only BCC is incorrect

Example To set parameter **1.25** at +76.4 for a Drive that is unit 6 of group 2, send:

Control	Address				Control	Parameter				Data				Control	BCC		
EOT	2	2	6	6	STX	0	1	2	5	+	0	7	6	.	4	ETX	%

A.5 Re-writing a parameter value

Once a write message which includes the address field has been sent to a Drive and accepted with either a <ACK> or <NAK> response, subsequent write messages to that particular Drive can use a re-write message structure in which the address does not need to be re-transmitted. The re-write structure is as follows:

STX	M1	M2	P1	P2	D1	...	Dn	ETX	BCC
------------	-----------	-----------	-----------	-----------	-----------	------------	-----------	------------	------------

When a different Drive is addressed, or an invalid character is received, the re-write facility no longer functions. The first Drive can be addressed again only by using the full write message with the address.

A.6 Calculating the block checksum (BCC)

The block checksum is calculated by applying an exclusive OR function to all of the characters of a message after the STX control character.

XOR truth table

A	B	Out
0	0	0
0	1	1
1	0	1
1	1	0

Example To set parameter **1.25** at -34.5

The first character of the BCC calculation is **0** (00110000 in binary), the value of which is taken as a starting or result value. The next character is **1** (00110001 in binary), which now has the exclusive OR (XOR) operator act upon it. With the previous result value, a new result occurs of 00000001 in binary.

The complete calculation is show in the table below:

Character	Binary Value	XOR result
0	0011 0000	
1	0011 0001	0000 0001
2	0011 0010	0011 0011
5	0011 0001	0000 0110
-	0010 1101	0010 1011
3	0011 0011	0001 1000
4	0011 0100	0010 1100
.	0010 1110	0000 0010
5	0011 0101	0011 0111
ETX	0000 0011	0011 0100

The final value is the BCC, provided that its equivalent decimal value exceeds 31 (ASCII characters from 00 to 31 are used as control codes).

When the final XOR result produces a decimal value less than 32, 32 is added. In this example, 0011 0100 is 52 decimal which is above 31, so this is the final BCC value. 52 decimal is the character 4. The complete message will be as follows:

Control	Address				Control	Parameter				Data				Control	BCC	
EOT	1	1	2	2	STX	0	1	2	5	-	3	4	.	5	ETX	4
Not included in the calculation						Included in the calculation									Result	

Example QuickBasic program to calculate BCC

```

mess$ = CHR$(4)+"1122"+CHR$(2)+"0125"+"-34.5"+CHR$(3)
bcc%= 0
FOR n%= 7 TO LEN(mess$)'start at the character after 'chr$(2).
bcc%= bcc% XOR ASC(MID$(mess$, n%, 1))
NEXT
IF bcc% < 32 THEN bcc%= bcc% + 32
mess$ = mess$ + CHR$(bcc%)
PRINT mess$

```

B Setting up the Drive using UniSoft

The UniSoft package is a Windows-based Drive set-up and commissioning program that is designed to enable complete control and display of all parameters in a Unidrive. UniSoft provides the user with a graphical interface that is logically split into a series of screens, offering quick and easy viewing and, where appropriate, editing of a parameter value. Individual detailed parameter information can at any time be displayed defining the parameters function, type and min/max permitted value.

Unisoft is available from your local Drive Centre.

PCs have an RS232 serial communications interface. To enable the PC to communicate with the Drive, either of the following must be used:

- RS232 to RS485 converter.
- A special serial communications cable having the connections shown below:

PC			UD78	
Terminal	Name		Terminal	Name
5	OV	----	1	OVSC
		----	6	TX
		----	7	RX
2	RXD	----	2	TX\
3	TXD	----	3	RX\

Connect terminals 1, 6, 7 of the UD78 together.

Recommended maximum cable length: 3m (10 ft)

Note

The special serial communications cable connected as shown above must be used only for temporary connection to the Drive. It must not be used for permanent installations.
