

**User Guide
Unidrive®
Digital AC Drives**

**Unidrive®
Using The Unidrive
with a Servomotor**



***CONTROL
TECHNIQUES***

Using the Unidrive with a Servomotor



P/N UNISRV-UG
Revision: A1
Date: March 8, 2002

© Control Techniques Drives, Inc. 2002

Part Number: UNISRV-UG

Revision: A1

Date: March 2002

Printed in United States of America

Information in this document is subject to change without notice. No part of this document may be reproduced or transmitted in any form or by any means, electronic or mechanical, for any purpose, without the express written permission of Control Techniques.

The trademarks of Control Techniques and may not be reproduced in any fashion without written approval of Control Techniques.

Control Techniques is a division of EMERSON Co.

Control Techniques, Inc. is not affiliated with Microsoft Corporation, owner of the Microsoft, Windows, and Windows NT trademarks.

This document has been prepared to conform to the current released version of the product. Because of our extensive development efforts and our desire to further improve and enhance the product, inconsistencies may exist between the product and documentation in some instances. Call your customer support representative if you encounter an inconsistency.

Customer Support

Control Techniques
12005 Technology Drive
Eden Prairie, Minnesota 55344-3620
U.S.A.

Telephone: (952) 995-8000 or (800) 397-3786

It is Control Techniques' goal to ensure your greatest possible satisfaction with the operation of our products. We are dedicated to providing fast, friendly, and accurate assistance. That is why we offer you so many ways to get the support you need. Whether it's by phone, fax or modem, you can access Control Techniques support information 24 hours a day, seven days a week. Our wide range of services include:

FAX	(952) 995-8099
------------	-----------------------

You can FAX questions and comments to Control Techniques. Just send a FAX to the number listed above.

Website and Email	www.emersonct.com
--------------------------	--------------------------

Website: www.emersonct.com

Email: info@emersonct.com

If you have Internet capabilities, you also have access to technical support using our website. The website includes technical notes, frequently asked questions, release notes and other technical documentation. This direct technical support connection lets you request assistance and exchange software files electronically.

Technical Support	(800) 367-6067
--------------------------	-----------------------

Email: service@emersonct.com

Control Techniques' products are backed by a team of professionals who will service your installation. Our technical support center in Eden Prairie, Minnesota and Grand Island NY are ready to help you solve those occasional problems over the telephone. Our technical support center is available 24 hours a day for emergency service to help speed any problem solving. Also, all hardware replacement parts, if needed, are available through our customer service organization.

When you call, please be at your computer, with your documentation easily available, and be prepared to provide the following information:

- Product version number, found by choosing About from the **Help** menu
- The type of controller or drive product you are using
- Exact wording of any messages that appear on your screen
- What you were doing when the problem occurred
- How you tried to solve the problem

Need on-site help? Control Techniques provides service, in most cases, the next day. Just call Control Techniques' technical support center when on-site service or maintenance is required.

Training Services**(800) 397-3786**

Email: training@emersonct.com

Control Techniques maintains a highly trained staff of instructors to familiarize customers with Control Techniques' products and their applications. A number of courses are offered, many of which can be taught in your plant upon request.

Application Engineering**(800) 893-2321 or (800) 397-3786**

Email: applengr@emersonct.com

An experienced staff of factory application engineers provides complete customer support for tough or complex applications. Our engineers offer you a broad base of experience and knowledge of electronic motion control applications.

Customer Service (Sales)**(800) 995-8000 or (800) 893-2321**

Email: customer.service@emersonct.com

Authorized Control Techniques distributors may place orders directly with our Customer Service department. Contact the Customer Service department at this number for the distributor nearest you.

Safety Instructions

General Warning

Failure to follow safe installation guidelines can cause death or serious injury. The voltages used in the product can cause severe electric shock and/or burns and could be lethal. Extreme care is necessary at all times when working with or adjacent to the product. The installation must comply with all relevant safety legislation in the country of use.

Qualified Person

For the purpose of this manual and product, a “qualified person” is one who is familiar with the installation, construction and operation of the equipment and the hazards involved. In addition, this individual has the following qualifications:

- Is trained and authorized to energize, de-energize, clear and ground and tag circuits and equipment in accordance with established safety practices.
- Is trained in the proper care and use of protective equipment in accordance with established safety practices.
- Is trained in rendering first aid.

1. Introduction

1.1 PURPOSE OF THIS MANUAL

This manual will assist the user in set up and using Unidrive with a servomotor.

1.2 EQUIPMENT IDENTIFICATION

A Uniservo package comprises a Unidrive and servomotor .

1.2.1 Unidrive Models.

Unidrive is available in two supply voltage ranges, 480V and 230V. The 480V Unidrives are available in five physical size ranges (1 through 5). The 230V Unidrives, known as Unidrive LV, are available in size 1 through 3. The 5 size ranges are illustrated and tabulated below. It should be noted that the current ratings shown in these tables are at 6kHz switching frequency. Unidrive has user selectable switching frequencies, for current output at other frequencies please refer to the full specifications at appendix A of this manual.



1. Introduction

460 V Unidrive Range, 6kHz Switching Frequency Ratings

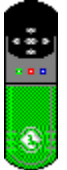
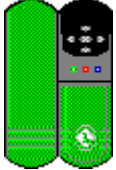
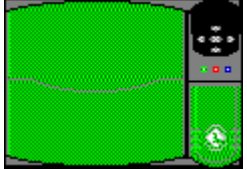
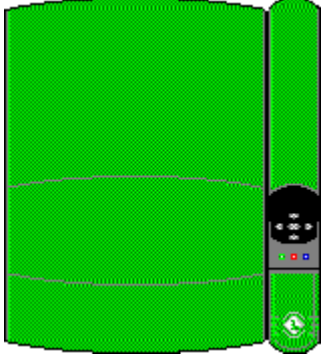

Case Style	Model Code	I Continuous	I Peak
 1	UNI 1401 UNI 1402 UNI 1403 UNI 1404 UNI 1405	2.1 A 2.8 A 3.8 A 5.6 A 8.5 A	3.7 A 4.9 A 6.7 A 9.8 A 14.9 A
 2	UNI 2401 UNI 2402 UNI 2403	12 A 16 A 18.2A	21 A 28 A 31.9 A
 3	UNI 3401 UNI 3402 UNI 3403 UNI 3404 UNI 3405	34 A 37 A 40 A 40 A 46 A	59.5 A 64.8 A 70 A 70 A 80.5 A
 4	UNI 4401 UNI 4402 UNI 4403 UNI 4404 UNI 4405	88 A 88 A 105 A 145 A 145 A	154 A 154 A 184 A 254 A 254 A

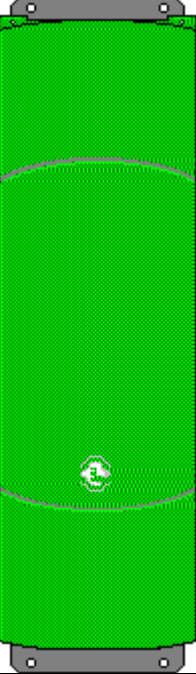
1. Introduction

	5	UNI 5401	240 A	360 A
		The size 5 Unidrive power modules may be connected in parallel to provide up to 1920 A continuous and 2850 A Peak. This is possible by linking up to 8 power modules and 1 control module . The drawing in this table shows only the power module. The control module is identical in size and shape to a size 1 Unidrive.		

1. Introduction

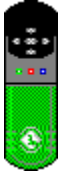
230 V Unidrive LV Range, 6kHz Switching Frequency Ratings

Case Style	Model Code	I Continuous	I Peak
 1	UNI 1203LV UNI 1204LV UNI 1205LV	3.8 A 5.6 A 5.6 A	6.7 A 9.8 A 9.8 A
 2	UNI 2201LV UNI 2202LV UNI 2203LV	12 A 16 A 18.2 A	21 A 28 A 31.9 A
 3	UNI 3201LV UNI 3202LV UNI 3203LV UNI 3204LV	34 A 40 A 40 A 46 A	59.5 A 70 A 70 A 80.5 A

Note:

For Unidrive size 1 through 4 the peak current output is 1.75 times the continuous current. If a greater ratio, for example 2:1 is needed by your application it is only necessary to select a drive **that** is able to supply the desired peak current. The continuous current limit would then be adjusted to the correct value to prevent motor damage.

1. Introduction

1.2.2 Servomotors:

Three **standard** ranges of servomotors are available from Control Techniques in North America. The Unimotor manufactured by Control Techniques Dynamics in UK, the Magna motor and the 230V NT motors manufactured by Emerson Drive Solutions in the US. These motor model ranges are tabulated in the following sub-sections. Control Techniques can also supply **GS** Linear and **PSA** rotary actuators (gear motors) suitable for use with Unidrive. **The highly flexible Unidrive is also capable of operating a wide variety of brushless servomotors from many different manufacturers.** Please consult the product catalog or your local **Control Techniques** office for details.

1. Introduction

1.2.2.1 Unimotor



Model Numbering Example

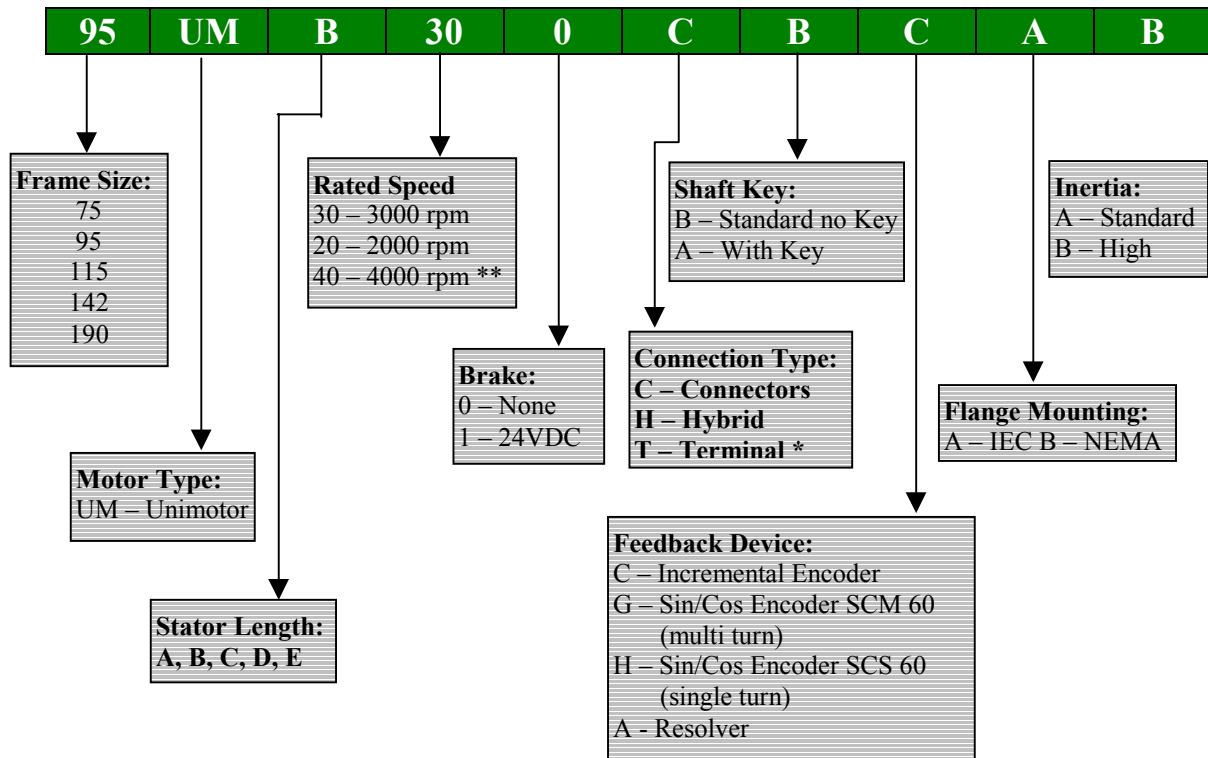

1. Introduction

- Available with resolver feedback motors only.

1. Introduction

1.2.2.2 Magna Motors:

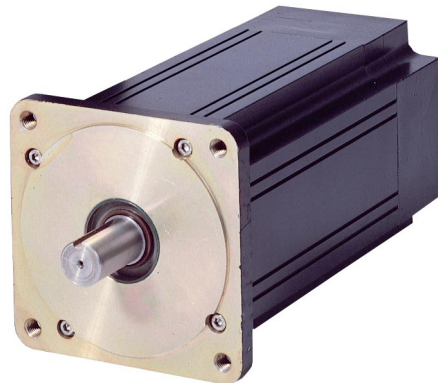

Model Numbering System Example

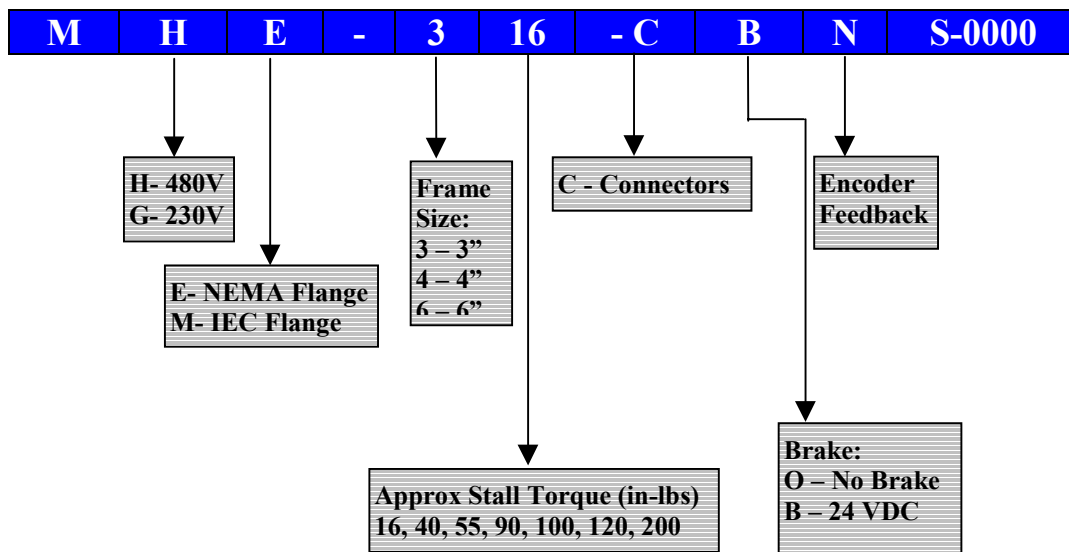

1. Introduction

1.2.2.3. NT Motors (230V for use with Unidrive LV)



Model Numbering System Example

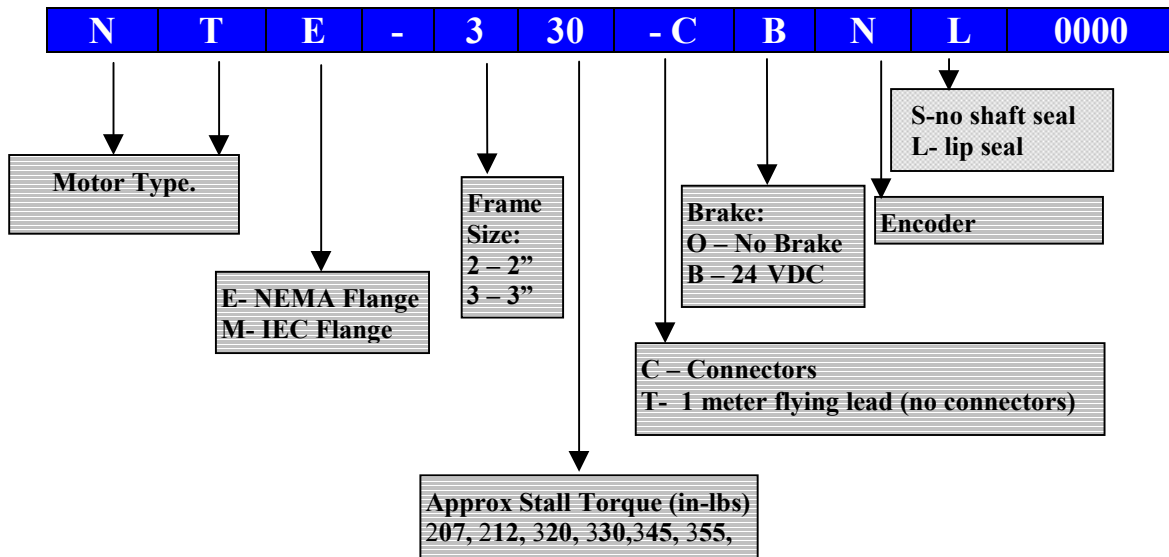

1. Introduction

1.3 Option Modules

The Unidrive is available with a number of option modules, which increase its flexibility and make it suitable for a very wide range of applications. These modules are briefly described in the following paragraphs. For full details refer to the individual product manuals supplied with each of them. The modules are in two physical formats and are known as Large Option Modules (LOM) and Small Option Modules (SOM). Each Unidrive may be fitted with one LOM and one SOM.

Unidrive Option Modules



Installed in a Drive

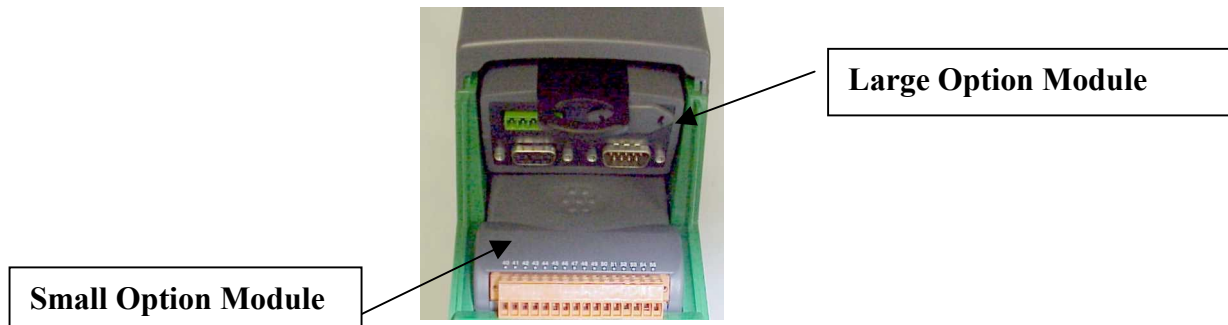

1.3.1 Large Option Modules

The following are the large option modules currently available for Unidrive.

1.3.1.1 UD78 High Precision Analog Input Module. (LOM):

This module provides the following features:

- a) Infinite resolution analog input for **precision** speed and position control.

1. Introduction

b) RS485 communication port.

c) Back up supply connector (requires user provided 24VDC) to maintain power to the drive control circuits and encoder feedback when the 3 phase input to the drive is disconnected.

1.3.1.2 UD70 Co-Processor Module (LOM)

The UD70 is an Intel 960 based co processor module that allows the user to write programs in both IEC1131 ladder / Function Block Diagram and Drive Programming Language (DPL) to provide 1.5 axis motion control and sequence control. This is accomplished using the SyPT programming tool on a PC. The module is fitted with an RS232 programming port for this purpose. It also has an RS485 port for general use and this supports the ANSI protocol as a slave or master controller and ModBus RTU as a slave only.

1.3.1.3 UD71 Serial Communications Module (LOM)

The UD71 provides simple serial communication and has both RS232 and RS485 ports.

1.3.1.4 UD73 Profibus Interface Module (LOM)

The UD73 provides full UD70 co-processor functionality and additionally allows the drive to be connected to a Profibus DP network running at speeds up to 1.5 Mbaud.

1.3.1.5 UD74 Interbus-S Interface Module (LOM)

The UD74 provides full UD70 co-processor functionality and additionally allows the drive to be connected to an Interbus-S network at a fixed data rate of 500 Kbaud.

1.3.1.6 UD75 CTNet Interface Module (LOM)

The UD75 provides full UD70 co-processor functionality and additionally allows connection to a CTNet network. CTNet is Control Techniques fully de-centralized peer to peer fieldbus. This allows implementation of a fully distributed control system with no central PLC controller required.

1.3.1.7 UD76 Modbus Plus Interface Module (LOM)

The UD76 provides full UD70 co-processor functionality and additionally allows connection to a Modbus Plus network.

1.3.1.8 UD77 DeviceNet interface module (LOM)

The UD77 provides full UD70 co-processor functionality and additionally allows connection to a DeviceNet network.

1.3.1.9 Can interface module

This is based on the UD77 hardware but has different firmware to allow the user to communicate through the CAN physical layer but using his own protocol written using the SyPT toolkit.

1. Introduction

1.3.1.10 CanOpen interface module

This is based on the UD77 hardware but the firmware is changed so that the network uses the CanOpen protocol.

1.3.2 Small Option Modules:

The following are small option modules currently available for Unidrive.

1.3.2.1 UD50 Extended I/O module

This module provides the following additional I/O capability:

- a) qty. 3, 24VDC digital inputs.
- b) qty. 3, dual function (user selectable) 24VDC digital inputs / outputs. Rated at 30mA when configured as outputs.
- c) qty. 2, 10 bit plus sign analog inputs +10 to –10VDC
- d) qty. 1, analog output +10 to –10VDC.

1.3.2.2 UD51 Second encoder module

In servo mode this provides the drive with the following additional capabilities:

- a) Allows use of a second incremental encoder as a master reference input for digital lock, Electronic Gear box and camming functions.
- b) Alternatively the UD51 may be configured for frequency and direction input to be used as the drive speed reference.

1.3.2.2 UD52 Sin/Cos encoder module

The UD52 allows a servomotor fitted with a sin/cos encoder to be used. This provides an interpolated resolution of up to 1,048,576 ppr when used with a 512 pulse sin cos encoder and also allows use of an optional 4096 revolution absolute encoder. The Unimotor is available with these encoders fitted as a standard option.

1.3.2.3 UD53 Resolver Module

The UD53 allows use with a servomotor having resolver feedback. This is much more rugged than an encoder and therefore suitable for use in harsh environments. The UD53 can operate with resolver having either 2:1 or 3:1 turns ratio (primary : secondary)

1.3.2.4 UD55 Cloning Module

The cloning module is intended to make it possible to copy up to 8 different parameter sets and subsequently load any of these onto another drive. It is useful in a production environment when many drives have to be set up with the same parameters. Unlike the other small option modules it is not normally left permanently installed in a drive.

2. Installation & Wiring Guide

2.1 Installation

2.1.1 Mechanical Installation.

Refer to the Unidrive Installation guide Part number 0447-0088 for mechanical installation details for sizes 1 to 4. For size 5 refer to Part number 0447-0025.

2.1.2 Electrical Installation.

2.1.2.1 Size 1 & 2 Connection layout.

The first photograph below shows the connection terminal layout for size 1 and 2 Unidrives. Note that both control and power connections are made using **removable** terminal strips.

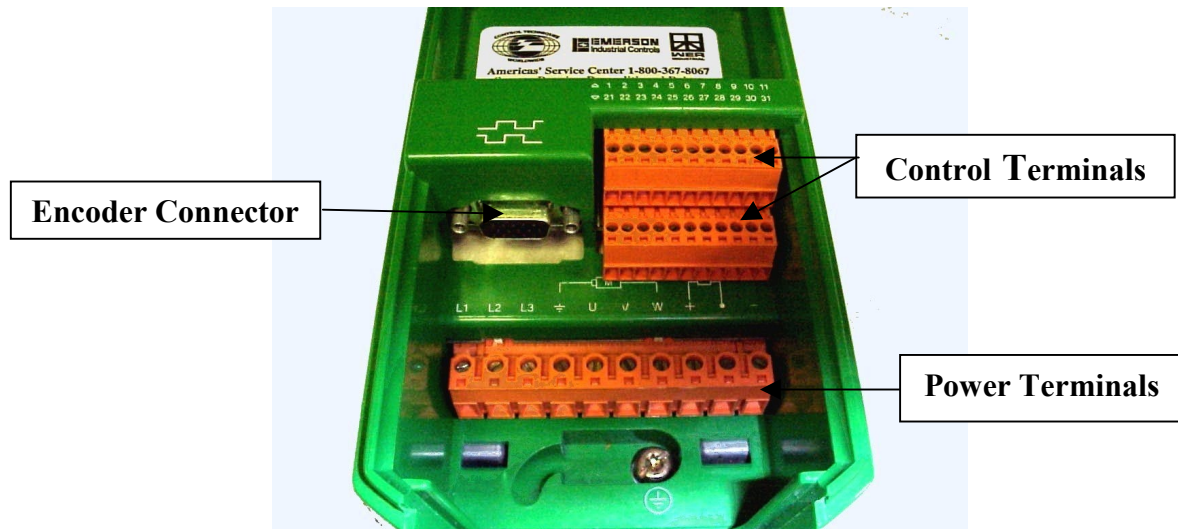

2. Installation & Wiring Guide

2.1.2.2 Unidrive Size 3, 4 & 5 Connection layout.

The photograph below shows a size 3 Unidrive. Sizes 4 and 5 are similar in that control wiring is done through **removable** terminal strips and power wiring is to studs using nuts and washers. Note that in all cases control wiring is identical to that shown for size 1.

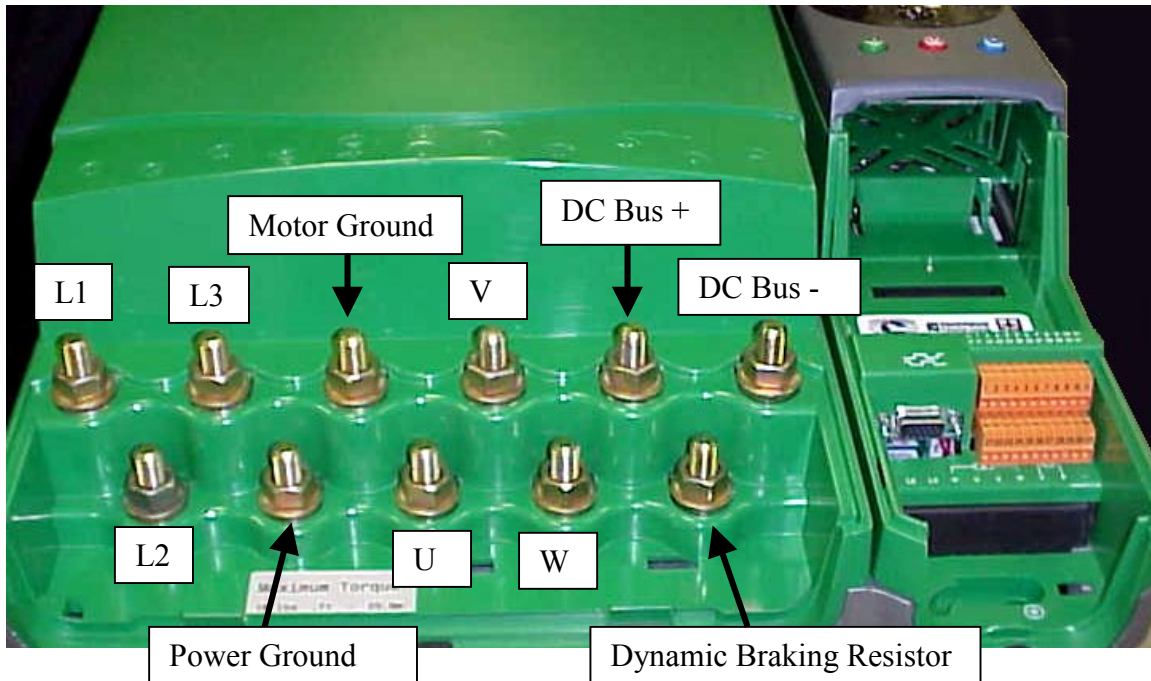

2. Installation & Wiring Guide

2.1.2.1 Drive Power Connections

Please refer to the Unidrive Installation guide, Part number 0447-0088 for power connection and wiring details for Unidrives size 1 to 4 or 0447-0025 for the Size 5.

2.1.2.2 Control Connections

The picture below is a close up showing the control terminal layout for all sizes of Unidrive. In keeping with the flexible nature of the Unidrive many of the terminal functions may be assigned through the drive parameter set. The default functions for these terminals are shown in the table below. Note the numbering format is 1-11 and 21-31 for the two rows.

Control Terminal layout

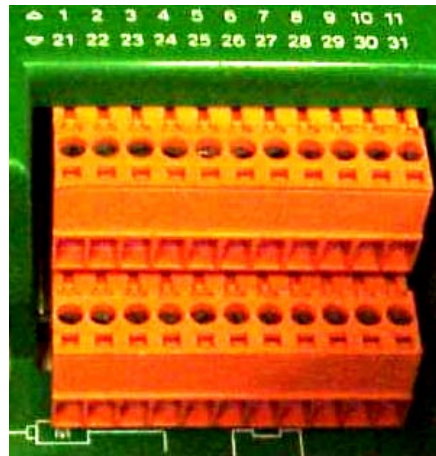

Default Terminal Functions

Note that terminals with fixed functions are shown shaded.

Term #	Function	Default Function Description
1	Status relay	Relay contact between terminals 1 &2 closes when drive is healthy and power is applied.
2	Status relay	
3	0V	Connect reference signal shield and common
4	+10VDC	+10 volt dc output can be used for speed pot
5	Analog input 1	Non inverting speed reference analog input
6	Analog input 1	Inverting speed reference analog input
7	Analog input 2	Single ended analog input see terminal 29 below
8	Analog input 3	Single ended analog input (motor thermistor)
9	Analog Output 1	Speed feedback output proportional to encoder count rate

2. Installation & Wiring Guide

10	Analog Output 2	Proportional to motor current (torque)
----	-----------------	--

2. Installation & Wiring Guide

11	Analog I/O 0v	Common for analog inputs 2 & 3, outputs 1 & 2
21	0 VDC	Common 0V connection
22	+24VDC	24VDC 200mA output. Foldback protected at >240mA
23	Digital output 0V	Common for digital I/O (internally connected to term 31)
24	Digital I or O 1	Motor at zero speed output (24V sourcing)
25	Digital I or O 2	Drive reset input
26	Digital I or O 3	Jog input
27	Digital input 1	Run forward
28	Digital input 2	Run reverse
29	Digital input 3	On selects analog input 2 as speed reference
30	Digital input 4	Drive enable
31	Digital Input 0V	Common for digital I/O (internally connected to term 23)

Notes:

1. Terminals 24, 25 and 26 can be individually configured, by parameter setting, as either inputs or 24VDC sourcing **outputs**.
2. For a typical servo application using an external position controller or PLC the default settings listed above may not be ideal and some reprogramming will be required.

2.1.2.3 Encoder Connection.

The main feedback encoder is connected through a 15 pin high density D connector. This may be connected using standard solder connections but it is highly recommended that a **UDBV1 connector be used if a standard feedback cable is not available**. The UDBV1 is shown below.

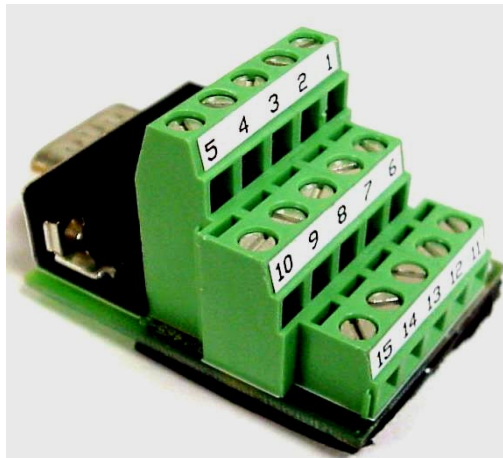

2. Installation & Wiring Guide

Standard Encoder Connector

Terminal #	Encoder Function	Frequency & Direction
1	Quadrature channel A	Frequency input FIN
2	Quadrature channel A/	Frequency input FIN/
3	Quadrature channel B	Direction input DIR
4	Quadrature channel B/	Direction input DIR/
5	Marker pulse channel Z	Not used
6	Marker pulse channel Z/	Not used
7	Commutation channel U	Frequency output FOUT
8	Commutation channel U/	Frequency output FOUT/
9	Commutation channel V	Direction output DOUT
10	Commutation channel V/	Direction output DOUT/
11	Commutation channel W	Not used
12	Commutation channel W/	Not used
13	+5 or +15 VDC	Not used
14	0 VDC & Shield	0 VDC common
15	Motor thermistor	Motor thermistor

Note: Connector can be configured as encoder feedback or frequency and direction. Unless the servomotor has resolver or sin/cos encoder feedback the drive will always be configured for encoder input.

Shielding Special Considerations:

Depending on the servomotor and encoder used the shield connection scheme should follow the rules below for best noise immunity.

Isolated Encoder:

Where the encoder is electrically isolated from the motor frame, as with the Unimotor, the shield should be grounded at both the drive and motor ends of the encoder cable.

Isolated poor encoder noise immunity:

Occasionally the encoder may be electrically isolated but suffer from poor noise immunity due to a high capacitance between the encoder and the motor frame. In this case the shield should be grounded **at the** drive end only.

Non Isolated:

If the encoder is not isolated from the motor frame the shield should be connected at the drive end only.

2. Installation & Wiring Guide

2.1.2.4 Encoder connections for CFOS cable use with Magna and NT motors.

This cable is supplied for use with the Magna and NT motors. It is also for use with the **GS and PSA** actuator products available for use with Unidrive. The cable comes with a connector at the motor end but is open at the drive. The following table shows the connections for this cable to Unidrive.

Motor Connector	Wire Color	Function	Unidrive pin #
A	Red / Green	Motor Overtemp Switch	15
B	Blue	Channel B	3
C	Orange	Channel B inverse	4
D	Not Used		
E	White / Brown	Channel V	9
F	White / Gray	Channel U	7
G	Red / Orange	Channel W	11
H	Orange / Red	Channel W inverse	12
J	Not Used		
K	Red / Blue	+5 VDC	13
L	Not Used		
M	Black	Channel Z (marker)	5
N	Green	Channel A	1
P	Brown	Channel A inverse	2
R	Brown / White	Channel V inverse	10
S	Gray / White	Channel U inverse	8
T	Blue / Red	0 VDC	14
U	Yellow	Channel Z inverse	6
V	Green / Red	Motor Overtemp common	14
W	Not Used		
X	Not Used		
Y	Not Used		
Z	Shield	Shield	14

2. Installation & Wiring Guide

2.1.2.5. Motor power connections for Magna and NT motors:

The Magna and NT motors together with the **GS and PSA** actuators use a CMMS or CMDS cable for power connection. This is wired as below:

Motor Connector	Color	Drive Terminal
A	Brown	U
B	Black	V
C	Blue	W
D	Green / Yellow	Ground
E	Not Used	
F	Not Used	
G	Not Used	

2. Installation & Wiring Guide

2.1.2.3 UD53 Resolver Option Module Wiring.

If the chosen motor is fitted with resolver feed back it will be necessary to use the UD53 small option module. In this case the 15 pin D connector on the drive can be used as a secondary encoder input if desired. The table below shows the connections for the resolver module. Cable having 3 individually shielded twisted pairs with an overall outer shield must be used for resolver connection. The UD53 also provides a simulated encoder output that can be used to provide position feed back to an external position controller such as an Axima. This output can be set, by parameter #16.08, to output either standard quadrature square waves or Frequency and Direction signals. Terminal connections for both of these options are shown in the table. The UD53 User guide gives more detail on the set up of this module.

Terminal	Function Quadrature Out	Function F & D out
40	Simulated Encoder Phase A	Frequency Out F
41	Simulated Encoder Phase A/	Frequency Out F/
42	0 Volts	0 Volts
43	Simulated Encoder Phase B	Direction Out D
44	Simulated Encoder Phase B/	Direction Out D/
45	0 Volts	0 Volts
46	Simulated Encoder Phase Z	Not Used
47	Simulated Encoder Phase Z/	Not Used
48	Sin Low	Sin Low
49	Sin High	Sin High
50	Cos Low	Cos Low
51	Cos High	Cos High
52	Excitation High	Excitation High
53	Excitation Low	Excitation Low
54	0 Volts	0 Volts
55	0 Volts	0 Volts

2. Installation & Wiring Guide

2.1.2.4. UD52 Sin Cos Option Module Wiring

If the chosen motor is fitted with Sin Cos encoder feed back it will be necessary to use a UD52 small option module. In this case the 15 pin D connector on the drive can be used for a secondary encoder. The UD52 also provides a simulated incremental encoder output **that** may be used for input to an external position controller such as Axima. The resolution of this is limited to the base resolution of the encoder, with a Unimotor this is 512 ppr and has no marker pulse. It should also be noted that the Axima does not support the absolute position capability of these encoders and that this information is not easily available outside the drive except by use of communications (supported Fieldbus or serial coms). The absolute position data can however be used by a position control program residing in a UD7x co-processor module. The following table shows the terminal functions of the UD52 connections. **Please note that in servo mode it is not possible to reverse the motor rotation by swapping the sin and cos connections together with 2 motor power phases. This is because the serial absolute data is always positive for clockwise rotation from absolute zero.** The UD52 and a sin cos encoder can be used without the serial data only on a vector motor application. In this case it is possible to reverse motor direction using the method outlined above.

Terminal	Function Quadrature Out	Function F & D Out
40	Sin input from encoder	Unchanged
41	Sin reference from encoder	Unchanged
42	Cos input from encoder	Unchanged
43	Cos reference from encoder	Unchanged
44	0 volts common	Unchanged
45	+ Venc (8 or 5) volts DC	Unchanged
46	Serial Data (RS485)	Unchanged
47	Serial Data / (inverse)	Unchanged
48	Freeze Input (RS485)	Unchanged
49	Freeze / Input (RS485)	Unchanged
50	Simulated encoder phase A	Frequency output
51	Simulated encoder phase A/	Frequency / (inverse) output
52	0 Volts common	Unchanged
53	Simulated encoder phase B	Direction output
54	Simulated encoder phase B/	Direction / (inverse) output
55	0 Volts common	Unchanged

Please note that this module may not be suitable for use in an application using an external position controller such as Axima. This is because of the following limitations:

- 1. No marker pulse available to use for axis reference.**
- 2. Absolute position data not easily available to the controller.**
- 3. Limited resolution (normally 512 ppr).**

2. Installation & Wiring Guide

2.2.2.5. Unimotor sin cos encoder cable connections:

The table below shows connections for the standard sin cos feed back cable (type SSBAC) for Unimotor.

Motor pin #	Color	Function	UD52 term
5	Brown	Sin	40
6	Black	Sin reference	41
4	Orange	Cosine	42
1	Red	Cosine reference	43
10	Blue / White	0 VDC to encoder	44
12	Red / White	+8 VDC to encoder	45
2	Blue	RS485 out	46
3	Purple	inverse RS485 out	47
9	Black	Cable Shield	55
7	Yellow	Motor thermistor	8 *
8	Green	Motor thermistor	11 *

* Note that thermistor has to go to main **drive control** terminals as numbered and not the UD52.

2. Installation & Wiring Guide

2.2 Drive Parameter Setting.

The Unidrive uses numeric parameters to set up its operation. These parameters are arranged using a menu structure with up to 50 parameters in each menu. Only menu zero is available from power up unless the user enters a password. This is designed to protect the drive, motor and machine from possible damage caused by unauthorized changing of parameter values.

2.2.1 Unidrive Menu Structure

The Unidrive parameters are grouped in several menus arranged according to function. For example motor map parameters are programmed in menu 5. The table below details the function of each of the available menus. Each menu contains individual parameters numbered from 0 to 50 or some lower value if all the parameters are not used. Parameter 0 of menu 7 would be displayed as 7.00 and parameter 1 as 7.01. Parameter 0 of any menu is used to carry out special functions such as saving changes. The available special functions are the same whichever menu is active.

Menu	Function in Servo mode
0	User definable Basic set up parameters
1	Speed reference selection, limits & filters
2	Acceleration & Deceleration Ramps
3	Feedback, Frequency slaving and Speed loop control.
4	Current Loop control.
5	Machine control (Motor set up parameters.)
6	Drive sequencing and timer set up.
7	Analog input and output set up.
8	Digital input and output set up.
9	Programmable logic and motorized potentiometer set up.
10	Drive status and trip display.
11	Menu 0 definition, operating mode serial comms and security set up.
12	Programmable threshold detectors.
13	Internal position control (orientation) and frequency set up.
14	Optional PID controller set up.
15	Not used in servo mode.
16	Small option module (SOM) set up parameters.
17	Large option module (LOM) set up parameters
18	User definable parameters for use with co processor
19	As menu 18
20	Co processor parameters.

2. Installation & Wiring Guide

2.2.2 Navigating through the Menus

The photograph below shows the Unidrive Keypad and should be referred to while carrying out the procedures detailed.

Unidrive Keypad

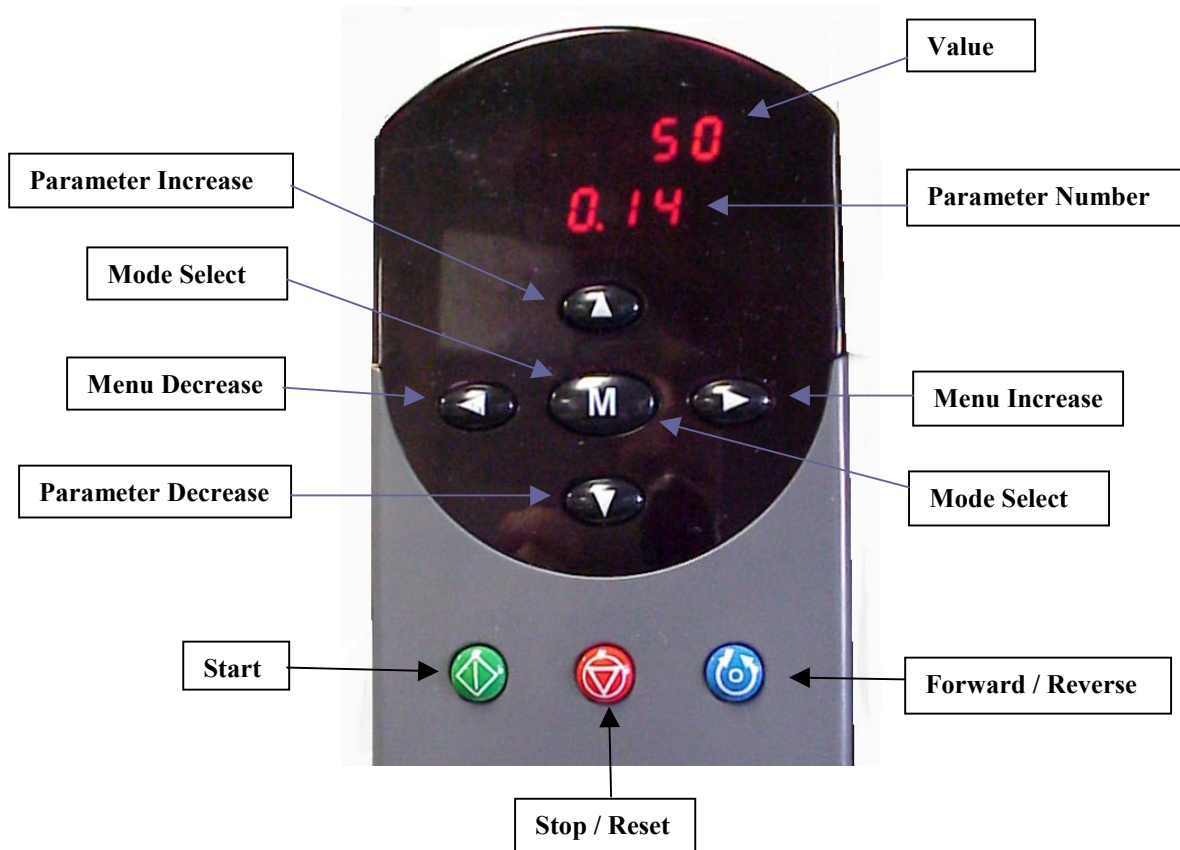

2.2.3 Accessing Menus other than zero.

2.2.3.1 Step1

After applying power to the drive the display will show “inh” on the parameter number line and “0” on the value line. Pressing the mode select key will change the display to read “0.10” on the parameter number line and “0” on the value line. This parameter is read only and displays the actual motor speed.

2. Installation & Wiring Guide

2.2.3.2 Step2

Press the Parameter decrease key until the parameter number is “0.00” (note that the arrow keys will all auto repeat if held down or you can press repeatedly to get to the desired number).

2.2.3.3 Step3

Press the Mode Select key, the number in the value line will flash.

2.2.3.4 Step 4

Use the Parameter increase key to enter a value of **149**. This can be achieved either by pressing and holding the key until 149 is displayed or use the menu decrease (left arrow) key to move to the next digit after 9 is displayed, then use the parameter increase (up arrow) to display 4. Use the left arrow to move digits again then up arrow to display 1. Once 149 is displayed press the Red Stop / Reset key.

2.2.4 Drive Mode Selection:

As shipped the Unidrive will be set for open loop mode. To change to servo use the following procedure.

2.2.4.1 Go to parameter 0.00

2.2.4.2 Enter a value of 1254 then press the mode key.

2.2.4.3 Go to parameter 0.48.

2.2.4.4 Use the up down arrows until the display shows “servo”

2.2.4.5 Now just press the mode key then the red reset key.

3. Incremental Encoder Feedback Start Up

3.1 Introduction

This section assumes that the drive, motor power, encoder and dynamic braking resistor (when required) have been wired in accordance with the installation section of this manual. A switch should be connected between terminals 30 and 31 of TB2 to act as drive enable. Ensure that this is in the off position until required. Final commissioning of the system will be dependent on the requirements of the individual application and is beyond the scope of this manual. **The motor should be mechanically disconnected from the load whilst the procedures described in this section are carried out.**

3.2. Pre-start:

Obtain the following motor and Encoder Data from the nameplate or the motor section of this manual:

1. Motor continuous stall current
2. Number of Motor Poles
3. Encoder PPR (Pulses/Rev)
4. Encoder Voltage. (standard motors are nominally 5V)

3.3. Procedure

3.3.1. Unplug the motor encoder cable.

3.3.2. Ensure motor is free to rotate.

3.3.3 Unplug drive terminal blocks TB1 and TB2.

3.3.4. Apply Power.

3.3.5. Depress both UP and Down arrow buttons on the drive keypad to take the menu display to 0.00

3.3.6. Set the drive parameters as shown in the table below: Note that the main menu parameter numbers are shown in parenthesis.

3. Incremental Encoder Feedback Start Up

Parameter Number	Setting	Comment
0.00	1254 then the RED button	To enable mode changes
0.48 (11.31)	Select Servo mode then RED button	
0.00	1244 then the RED button	To select USA Defaults
0.02 (1.06)	Max Motor RPM	Initially set for something less than intended full speed for safety
0.03 (2.11)	Accel Rate	Initially set for 0.8
0.04 (2.21)	Decel Rate	Initially set for 0.8
0.06 (4.07)	Symmetrical Current Limit	Initially set for 30-50%
0.42 (5.11)	Number of motor Poles	From nameplate
0.46 (5.07)	Motor Continuous Stall Current	From nameplate
0.00	149 to unlock security	To allow general access
2.04	1 FASt	Always in servo mode
3.08	Max Motor RPM + 100	Overspeed Trip Point
3.21	Encoder PPR	From nameplate
3.22	0 = quadrature encoder	Always in servo mode
3.23	0=+5v 1=+15v for Encoder	Always 5V for CT motors.
6.08	0	No Hold at Zero Speed
0.00	1000 then the RED button	Store this information thus far

Note: The acceleration and deceleration ramp parameters (0.03 & 0.04) have been selected to allow running a motor without need of a DB resistor. Depending on the application requirements and configuration a DB resistor may be required.

3.3.7. Remove main power

Caution

After power is removed, the **drive's cooling fans** and display will remain on for several seconds as the +700vdc bus discharges. The Drive contains high voltage capacitors that remain charged to a lethal potential long after the AC supply is disconnected. See Section 2-1 in the User Guide for details- STORED CHARGE

3.3.8. Plug in the encoder cable and TB2.

3.3.9. Re-Apply Power.

3. Incremental Encoder Feedback Start Up

3.3.10. *Check Encoder for proper operation.* Observe parameter #3.27. It should count up as you rotate the motor shaft CW (and down for CCW rotation) as viewed from the shaft end. The counter should roll over at 16384 after one complete shaft rotation.

3.3.11. If Encoder appears to be **operating correctly with the static checks**, you are ready to perform the phasing test. If not, review **Initial Encoder Problems**.

3.3.12. An encoder phasing test should now be carried out as outlined in the following table. When this is done the motor should rotate CW viewed from the shaft end for approximately 1 revolution and stop. Parameter 0.40 will be reset. If no alarms are displayed during this operation phasing is complete. See notes on the next page for possible problems. An offset value will be inserted in parameter #3.28.

Parameter Number	Setting	Comment
0.40 (3.25)	1	To enable phasing test
Close the Enable Switch	Pins 30-31	

Notes:

- 1. Enabling the drive before the phasing test may cause a trip with alarm **ENC9**.*
- 2. If the motor rotates CCW, disable the drive, remove power (wait until display goes dark and bus discharges completely) then swap any two motor phases.*
- 3. If the motor rotates CW but an **ENC4** alarm is displayed swap the V *with Y* and V/ *with Y* encoder commutation phases.*

3.3.13. Save the parameters at this stage by entering 1000 in parameter 0.00 and pressing the red reset key.

3.3.14. Verify proper drive/motor operation using keypad mode. Set the parameters to values shown in the following table and the drive can be stopped and started using the Green and Red keys on the keypad. Motor speed is controlled with the Up / Down Arrow keys.

3. Incremental Encoder Feedback Start Up

Parameter Number	Setting	Comment
6.01	rP	Set for Ramp to stop
0.05 (1.14)	4	Enable Keypad Operation
0.10	Depress M (Mode)	rdY & 0 Should appear
Depress the Green (Run) button		
Depress UP and hold		Drive should accelerate CW
Depress the RED (Stop) button		Drive should decelerate and go off
0.00	1000 then the RED button	Store this information thus far

Note: Parameter 0.10 displays motor speed during this test.

3.3.15. If the drive trips with an ENCPH4 alarm, press both the up and down arrow keys to set the commanded speed to zero and go to step 3.3.16. If the motor runs correctly go to step 3.3.17.

3.3.16. Remove power (wait for drive display to blank) and swap the connections to U, V and U/, V/ encoder commutation phases. Repeat steps from 12.

3.3.17. Adjust the speed loop proportional and integral gains (#3.10 and #3.11) as required to achieve stable running. Procedures shown in the Tuning and commissioning section of this manual should now be followed to set up the drive for correct operation of the application.

3.3.18. If it is desired to run the drive from the keypad in both directions this can be achieved by setting parameter 6.13 to 1. The direction can then be toggled by operating the blue key on the drive keypad.

3.3.19. If it is required to hold position at zero speed set **6.08** to 1.

3.3.20. It is also possible to run the drive in speed control from a potentiometer by connecting the ends across terminals 4 & 11 and the wiper to terminal 7. Enable this mode by setting parameters to values shown in the following table.

Parameter Number	Setting	Comment
6.04	0	Control Mode
6.11	1	Enable Keypad RUN
6.12	1	Enable Keypad STOP
6.34	1	Run Permit
0.05 (1.14)	2	To select Pot as Reference

3. Incremental Encoder Feedback Start Up

3.3.21. Before running the motor in this mode it is a good idea to verify the pot. reference by observing parameter #1.01 while rotating the pot from full CCW to full CW. Its value should range from zero to the full RPM reference set in parameter 0.02. If the value of #1.01 increases in the negative direction, reverse the pot wires on terminals 4 & 11.

3.3.22. The drive can also be set up so that the motor shaft will always stop at a preset angular position (shaft orientation). This is achieved by setting parameters as shown in the following table. The angular position is programmed in increments of 1/4096 revolution. To achieve the desired position first test with a value of zero in parameter 13.11. This will now stop the shaft at the rotor null position. The required stop position in should now be entered as (360/4096) counts.

Parameter Number	Setting	Comment
6.08	1	To Hold shaft a zero after stop
13.08	6	To set for orient mode
13.11	Your desired shaft position	In encoder counts

Orientation will operate under the following circumstances:

Upon Closure of TB2 30-31 Enable

If RUN (Green) then STOP (red) is depressed (if #6.34 Run Permit=1)

3.4. Changing Forward Direction

The foregoing procedure sets up the drive so that the motor turns in the clockwise direction for a positive speed reference. The speed display will also be positive. If the application requires that the motor runs counter clockwise for a positive reference it is only necessary to reverse the wires going to A and A/ of the encoder and any two motor phases. The encoder will also have to be re-phased as described in section 3.2.2.12 above. Initial Encoder Problems

- If #3.27 counts and rolls over but only counts to 8192, re-check the encoder PPR value and parameter #3.21 setting. For example this would occur is the encoder was actually a 2048 PPR but #3.21 was set to 4096.
- If #3.27 counts but rolls over after 0.5 revolutions re-check the encoder PPR value and parameter #3.21 setting. For example this would occur is the encoder was actually a 2048PPR but #3.21 was set to 1024.
- If #3.27 does not count --- re-check encoder wiring. Specifically channels A, /A and B, /B and power supply.

Measure the encoder supply voltage

3. Incremental Encoder Feedback Start Up

- If #3.27 counts but counts down rather than up for CW rotation. Swap A and /A. Re-check.

4. Resolver Feedback Start Up

4.1 Introduction

This section assumes that the drive, motor power and dynamic braking resistor (when required) have been wired in accordance with the installation section of this manual. The drive should be fitted with a UD53 Resolver module and the motor resolver wired in accordance with the instructions given in the UD53 manual. A switch should be connected between terminals 30 and 31 of TB2 to act as drive enable. Ensure that this is in the off position until required. Final commissioning of the system will be dependent on the requirements of the individual application and is beyond the scope of this manual. **The motor should be mechanically disconnected from the load whilst the procedures described in this section are carried out.**

4.2 Pre-start.

Obtain the following motor and Resolver Data from the nameplate or the motor section of this manual:

4.2.1. Motor continuous stall current

4.2.2. Number of Motor Poles

4.2.3. Resolver Transformation (Turns) Ratio. Note: only 3:1 and 2:1 are supported by the UD53

4.3 Procedure

4.3.1. Unplug the motor resolver cable either at the motor or at the UD53.

4.3.2. Ensure motor is free to rotate.

4.3.3. Unplug drive terminal blocks TB1 and TB2.

4.3.4. Apply Power.

4.3.5. Depress both UP and Down arrow buttons on the drive keypad to take the menu display to 0.00

4.3.6. Set the drive parameters as shown in the table below: Note that the main menu parameter numbers are shown in parenthesis.

4. Resolver Feedback Start Up

Parameter Number	Setting	Comment
0.00	1254 then the RED button	To enable mode changes
0.48 (11.31)	Select Servo mode then RED button	
0.00	1244 then the RED button	To select USA Defaults
0.02 (1.06)	Max Motor RPM	Initially set for something less than intended full speed for safety
0.03 (2.11)	Accel Rate	Initially set for 0.8
0.04 (2.21)	Decel Rate	Initially set for 0.8
0.06 (4.07)	Symmetrical Current Limit	Initially set for 30-50%
0.42 (5.11)	Number of motor Poles	From nameplate
0.46 (5.07)	Motor Continuous Stall Current	From nameplate
0.00	149 to unlock security	To allow general access
2.04	1 FASt	Always in servo mode
3.08	Max Motor RPM + 100	Overspeed Trip Point
16.10	Resolver transformation ratio	CTD motors are 3:1= 0 (2:1=1)
6.08	0	No Hold at Zero Speed
0.00	1000 then the RED button	Store this information thus far

Note: The acceleration and deceleration ramp parameters (0.03 & 0.04) have been selected to allow running a motor without need of a DB resistor. Depending on the application requirements and configuration a DB resistor may be required.

4.3.7. Remove main power

Caution

After power is removed, the **drive's cooling fans** and display will remain on for several seconds as the +700vdc bus discharges. The Drive contains high voltage capacitors that remain charged to a lethal potential long after the AC supply is disconnected. See Section 2-1 in the User Guide for details- STORED CHARGE

4.3.8. Plug in the resolver cable and TB2.

4.3.9. Re-Apply Power.

4. Resolver Feedback Start Up

4.3.10. *Check Resolver for proper operation.* Observe parameter #16.03 It should count up as the motor shaft is rotated CW (and down for CCW rotation) as viewed from the shaft end. The counter should roll over at 16384 after one complete shaft rotation. If the motor shaft rotates less than one turn the resolver may be driven through a gear reduction. This makes the motor unsuitable for use with the Unidrive.

4.3.11. If the resolver appears to **operate correctly** with the static checks, you are ready to perform the phasing test. If not, recheck the wiring from the resolver to the UD53.

4.3.12. A resolver phasing test should now be carried out as outlined in the following table. When this is done the motor should rotate CW viewed from the shaft end. It should initially jump 1/N revolutions where N is the number of motor poles followed by subsequent rotation of 4/N revolutions. Parameter 16.05 will be reset. If no alarms are displayed during this operation phasing is complete. See notes on the next page for possible problems. An offset value will be inserted in parameter 16.09.

Parameter Number	Setting	Comment
16.05	1	To enable phasing test
Close the Enable Switch	Pins 30-31	

Notes:

- 1. Enabling the drive before the phasing test may cause a trip with alarm **ENC9**.*
- 2. If the motor rotates CCW, disable the drive , remove power (wait until display goes dark and bus discharges completely) then swap any two motor phases.*
- 3. If the motor has a high rotor inertia it may be necessary to set parameter 5.27 to 1 before carrying out the test.*

4.3.13. Save the parameters at this stage by entering 1000 in parameter 0.00 and pressing the red reset key.

4.3.14. Verify proper drive/motor operation using keypad mode. Set the parameters to values shown in the following table and the drive can be stopped and started using the Green and Red keys on the keypad. Motor speed is controlled with the Up / Down Arrow keys.

4. Resolver Feedback Start Up

Parameter Number	Setting	Comment
6.01	rP	Set for Ramp to stop
0.05 (1.14)	4	Enable Keypad Operation
0.10	Depress M (Mode)	rdY & 0 Should appear
Depress the Green (Run) button		
Depress UP and hold		Drive should accelerate CW
Depress the RED (Stop) button		Drive should decelerate and go off
0.00	1000 then the RED button	Store this information thus far

4.3.15. Adjust the speed loop proportional and integral gains (#3.10 and #3.11) as required to achieve stable running.

4.3.16. Procedures shown in the Tuning and commissioning section of this manual should now be followed to set up the drive for correct operation of the application.

4.3.17. If it is desired to run the drive from the keypad in both directions this can be achieved by setting parameter 6.13 to 1. The direction can then be toggled by operating the blue key on the drive keypad.

4.3.18. If it is required to hold position at zero speed set **6.08** to 1.

4.3.19. It is also possible to run the drive with speed control from a potentiometer by connecting then ends across terminals 4 & 11 and the wiper to terminal 7. Enable this mode by setting parameters to values shown in the following table.

Parameter Number	Setting	Comment
6.04	0	Control Mode
6.11	1	Enable Keypad RUN
6.12	1	Enable Keypad STOP
6.34	1	Run Permit
0.05 (1.14)	2	To select Pot as Reference

4.3.20. Before running the motor in this mode it is a good idea to verify the pot reference by observing parameter #1.01 while rotating the pot from full CCW to full CW. Its value should range from zero to the full RPM reference set in parameter 0.02. If the value of 1.01 increases in the negative direction reverse the pot wires on terminals 4 & 11.

4. Resolver Feedback Start Up

4.3.21. The drive can also be set up so that the motor shaft will always stop at a preset angular position (shaft orientation). This is achieved by setting parameters as shown in the following table. The angular position is programmed in increments of 1/4096 revolution. To achieve the desired position first test with a value of zero in parameter #13.11. This will stop the shaft at the rotor null position. The required stop position in could now be entered as (360/4096).

Parameter Number	Setting	Comment
6.08	1	To Hold shaft a zero after stop
13.08	6	To set for orient mode
13.11	Your desired shaft position	In encoder counts

Orientation will operate under the following circumstances:

1. Upon Closure of TB2 30-31 Enable
2. If RUN (Green) then STOP (red) is depressed (if #6.34 Run Permit=1)

4.4. Changing Forward Direction

The foregoing procedure sets up the drive so that the motor turns in the clockwise direction for a positive speed reference. The speed display will also be positive. If the application requires that the motor runs counter clockwise for a positive reference it is only necessary to reverse the wires going to Sin Hi and Sin Lo of the resolver and any two motor phases. The resolver will also have to be re-phased as described in section 4.3.12 above.

5. Sin Cos Encoder Feedback Start Up

5.1 Introduction

This section assumes that the drive, motor power and dynamic braking resistor (when required) have been wired in accordance with the installation section of this manual. The drive should be fitted with a UD52 Sin/cos module and the motor encoder wired in accordance with the instructions given in the UD52 manual. A switch should be connected between terminals 30 and 31 of TB2 to act as drive enable. Ensure that this is in the off position until required. Final commissioning of the system will be dependent on the requirements of the individual application and is beyond the scope of this manual. **The motor should be mechanically disconnected from the load whilst the procedures described in this section are carried out.**

5.2 Servo Motor with Sin/cos Encoder Feed back.

At the time of writing the sin/cos encoder is available with 2 options. Single turn absolute and multi (4096) turn absolute. A Unidrive and servo motor fitted with this option will know the absolute position of the motor shaft immediately on power up. This is possible because the encoder uses multiple encoded disks to read the position **that** it transmits to the UD52 through a serial communications link. This means that commutation phases are not necessary. The basic resolution of the sin cos signals to the drive is 512 ppr. The UD52 converts these to standard quadrature square waves giving 2048 pulses. It then uses the sine wave to further divide each pulse into another 2048 edges. In this way the effective resolution is extended to 1,048,576. This resolution is also available for position control when a UD70 module is used. **It should be noted that the simulated encoder output of the UD52 is only equal to the base resolution of the encoder. (512 ppr). This means that the enhanced resolution is not available when an external position controller such as Axima is used. The commutation of the motor is much improved and the system can be run with much higher velocity loop gains than a traditional encoder or resolver could be.**

5.2.1 Pre-start:

Obtain the following motor and Encoder Data from the nameplate or the motor section of this manual:

1. Motor continuous stall current
2. Number of Motor Poles
3. Base resolution of the encoder.
4. Single or 4096 turn absolute.

5.3 Procedure

5.3.1. Unplug the motor encoder cable either at the motor or at the UD53.

5. Sin Cos Encoder Feedback Start Up

5.3.2. Ensure motor is free to rotate.

5.3.3. Unplug drive terminal blocks TB1 and TB2.

5.3.4. Apply Power.

5.3.5. Depress both UP and Down arrow buttons on the drive keypad to take the menu display to 0.00

5.3.6. Set the drive parameters as shown in the table below: Note that the main menu parameter numbers are shown in parenthesis.

Parameter Number	Setting	Comment
0.00	1254 then the RED button	To enable mode changes
0.48 (11.31)	Select Servo mode then RED button	
0.00	1244 then the RED button	To select USA Defaults
0.02 (1.06)	Max Motor RPM	Initially set for something less than intended full speed for safety
0.03 (2.11)	Accel Rate	Initially set for 0.8
0.04 (2.21)	Decel Rate	Initially set for 0.8
0.06 (4.07)	Symmetrical Current Limit	Initially set for 30-50%
0.42 (5.11)	Number of motor Poles	From nameplate
0.46 (5.07)	Motor Continuous Stall Current	From nameplate
0.00	149 to unlock security	To allow general access
2.04	1 FASt	Always in servo mode
3.08	Max Motor RPM + 100	Overspeed Trip Point
16.12	Encoder PPR	Usually 512 for Unimotor
16.13	Number of revolutions 0 or 12	0 for single, 12 for 4096 turns.
16.15	Encoder voltage 1 =8V	For Unimotor
6.08	0	No Hold at Zero Speed
0.00	1000 then the RED button	Store this information thus far

Note: The acceleration and deceleration ramp parameters (0.03 & 0.04) have been selected to allow running a motor without need of a DB resistor. Depending on the application requirements and configuration a DB resistor may be required.

5.3.7. Remove main power

5. Sin Cos Encoder Feedback Start Up

Caution

After power is removed, the drive's cooling fans and display will remain on for several seconds as the +700vdc bus discharges. The Drive contains high voltage capacitors that remain charged to a lethal potential long after the AC supply is disconnected. See Section 2-1 in the Unidrive User Guide for details- STORED CHARGE

5.3.8. Plug in the encoder cable. Plug in TB2 with a switch in the off (open) position connected to TB2 pins 30 and 31. (common – drive enable)

5.3.9. Re-Apply Power.

5.3.10. *Check Encoder for proper operation.* Observe parameter #16.04 It should count up as the motor shaft is rotated CW (and down for CCW rotation) as viewed from the shaft end. The counter should roll over at 16,384 after one complete shaft rotation. If the motor shaft rotates more or less than one turn parameter #16.12 is incorrectly set.

5.3.11. If the above checks are correct perform the phasing test described below. If not check the wiring from the encoder to the UD52.

5.3.12. An encoder phasing test should now be carried out as outlined in the following table. When this is done the motor should rotate CW viewed from the shaft end. It should initially jump 1/N revolutions where N is the number of motor poles followed by subsequent rotation of 4/N revolutions. Parameter 16.10 will be reset. If no alarms are displayed during this operation phasing is complete. See notes on the next page for possible problems. An offset value will be inserted in parameter 16.09.

Parameter Number	Setting	Comment
16.10	1	To enable phasing test
Close the Enable Switch	Pins 30-31	

Notes:

1. Enabling the drive before the phasing test may cause a trip with alarm *ENC9*.
2. *If the motor rotates CCW, disable the drive , remove power (wait until display goes dark and bus discharges completely) then swap any two motor phases.*
3. *If the motor has a high rotor inertia it may be necessary to set parameter 5.27 to 1 before carrying out the test.*

5.3.13. Save the parameters at this stage by entering 1000 in parameter 0.00 and pressing the red reset key.

5.3.14. Verify proper drive/motor operation using keypad mode. Set the parameters to values shown in the following table and the drive can be stopped and started using the

5. Sin Cos Encoder Feedback Start Up

Green and Red keys on the keypad. Motor speed is controlled with the Up / Down Arrow keys.

5. Sin Cos Encoder Feedback Start Up

Parameter Number	Setting	Comment
6.01	rP	Set for Ramp to stop
0.05 (1.14)	4	Enable Keypad Operation
0.10	Depress M (Mode)	rdY & 0 Should appear
Depress the Green (Run) button		
Depress UP and hold		Drive should accelerate CW
Depress the RED (Stop) button		Drive should decelerate and go off
0.00	1000 then the RED button	Store this information thus far

5.3.15. Adjust the speed loop proportional and integral gains (#3.10 and #3.11) as required to achieve stable running.

5.3.16. Procedures shown in the Tuning and commissioning section of this manual should now be followed to set up the drive for correct operation of the application.

5.3.17. If it is desired to run the drive from the keypad in both directions this can be achieved by setting parameter 6.13 to 1. The direction can then be toggled by operating the blue key on the drive keypad.

5.3.18. If it is required to hold position at zero speed set 6.08 to 1.

5.3.19. It is also possible to run the drive with speed control from a potentiometer by connecting then ends across terminals 4 & 11 and the wiper to terminal 7. Enable this mode by setting parameters to values shown in the following table.

Parameter Number	Setting	Comment
6.04	0	Control Mode
6.11	1	Enable Keypad RUN
6.12	1	Enable Keypad STOP
6.34	1	Run Permit
0.05 (1.14)	2	To select Pot as Reference

5.3.20. Before running the motor in this mode it is a good idea to verify the pot reference by observing parameter #1.01 while rotating the pot from full CCW to full CW. Its value should range from zero to the full RPM reference set in parameter 0.02. If the value of 1.01 increases in the negative direction reverse the pot wires on terminals 4 & 11.

5. Sin Cos Encoder Feedback Start Up

5.3.21. The drive can also be set up so that the motor shaft will always stop at a preset angular position (shaft orientation). This is achieved by setting parameters as shown in the following table. The angular position is programmed in increments of 1/4096 revolution. To achieve the desired position first test with a value of zero in parameter #13.11. This will stop the shaft at the rotor null position. The required stop position in could now be entered as (360/4096).

Parameter Number	Setting	Comment
6.08	1	To Hold shaft a zero after stop
13.08	6	To set for orient mode
13.11	Your desired shaft position	In encoder counts

Orientation will operate under the following circumstances:

1. Upon Closure of TB2 30-31 Enable
2. If RUN (Green) then STOP (red) is depressed (if #6.34 Run Permit=1)

6. Application Guide

6.1 Introduction:

This section will outline how Unidrive in servo mode may be used in the following system configurations:

- a) As a stand alone servo drive, possibly as part of a motion system using analog reference for velocity or torque control. An Axima multi axis position controller is a good example of this type of application.
- b) With a UD7x co processor large option module.

6.1.1 General

The Unidrive has some specific set up requirements which are valid for any of the system configurations to be covered here. These are covered in detail below.

6.1.1.1 Motor Thermal Protection.

In addition to the thermostat or thermistor devices fitted to most servo motors for protection the Unidrive uses sophisticated thermal modeling techniques to prevent the motor from overheating due to over current or excessive duty cycle demands in an application. This provides the best protection for the motor but it must be set up correctly or the application may suffer either from motor overheating or from premature overload trips and current limit foldbacks. A full operational description of this scheme follows below.

6.1.1.1.1 Explanation of rated current (#5.07):

The rated or continuous current of a servomotor is that current which causes the winding temperature to stabilize at the maximum permitted value. Although this may vary depending on wire material and motor design a typical value would be 135 degrees Celsius.

6.1.1.1.2 Overcurrent situations.

If the load on the motor causes current to be drawn in excess of the continuous value the following will occur:

1. The motor winding temperature will rise more quickly dependent on the actual excess of current draw over the continuous rating.
2. If the current excess is permitted to continue the temperature will eventually stabilize at some value beyond the maximum permissible allowed (in our example 135 degrees). This would either burn out the windings or if the installation is correctly implemented the motor thermal protection device (thermostat or thermistor) would operate and trip the drive

6.1.1.1.3 Thermal Time Constant #4.15

The motor manufacturer often has derived a thermal time constant for the motor windings. One time constant is the time in seconds taken for the winding

6. Application Guide

temperature to reach 63.2% of the maximum temperature with rated current flowing. This data may not always be published by the motor manufacturer. Values for the Unimotor are given in Appendix B of this manual. No values are yet published for the Magna and NT motors and it is suggested that the value for the Unimotor nearest in size to the actual motor is used.

6.1.1.1.3. Unidrive Protection Scheme.

Instantaneous over current trip OI.AC will occur if current draw exceeds 215% of the drive rated value. This is primarily to protect the Unidrive not the motor. The “It” accumulator overload It.AC. This will occur when the thermal overload accumulator, parameter #4.19 Reaches 100%.The effect of this depends on the setting of parameter #4.16. If #4.16 is set to its default value of 0 the drive will trip but if #4.16 = 1 then the drive output current will fold back to the motor rated current set in parameter #5.07. The way in which the overload accumulator functions is explained in the following section of this document.

Peak current limits. These are the values loaded into parameters #4.05, #4.06 and #4.07. The drive will limit its maximum output current to these values. A typical servo application will use the symmetrical limit in parameter #4.07.

6.1.1.1.4 Thermal Accumulator (parameter #4.19).

If the motor rated current (#5.07) and the motor thermal time constant (#4.15) have been correctly set the accumulator will model the winding temperature of the motor. This is scaled such that the trip or fold back point of 100% equates to a motor winding temperature 105% of the maximum. The time to trip (or fold back) for a given maintained overload can be calculated using the following formula. $T = -(\#4.15) * \ln(1-(105^2 / (\text{current as \% of \#5.07})^2))$

As an example assume the following:

Rated current (#5.07) = 10 amps

Actual current draw = 15 amps = 150%

Thermal time constant (#4.15) = 89 secs.

Therefore:

$T = -89 * \ln(1-(105^2 / 150^2)) = 60 \text{ seconds}$

In reality this is an oversimplification since a servomotor will usually be performing a more or less complex motion profile. This should be taken into account by using the current draw in the acceleration, steady motion, deceleration and dwell phases of the profile to calculate the RMS current. Input the calculated RMS current as a percentage of motor rated current (#5.07) to the above formula to calculate the trip or current fold back time. **In a correctly sized application the RMS current will be less than the rated current of the motor so that a trip or fold back should not occur during normal operation.**

6. Application Guide

Notes:

1. If all of the relevant parameters are correctly set, with a running motor the accumulator will always display a value equal to the motor winding temperature expressed as a percentage of the trip point temperature.
2. If the motor has been running at its rated current for sufficient time for the winding temperature to reach and stabilize at maximum, **any** over current will (**and should**) cause a trip or fold back to occur after a very short time.

6.1.1.2 Tuning

Tuning of a Unidrive servo system is similar to most other drives when used in velocity mode. The basic technique is to first tune the drive velocity loops for best response to a small step change in velocity reference commensurate with stability and then to tune any position loop used in either an external position controller, such as Axima or the drive co processor option module software. It is also possible to use the Unidrive in torque mode with position controllers which support this (Axima is one example). The advantage to this approach is that there is no velocity loop tuning required.

The latest versions of Unisoft (V3.4.3 and above) include Velocity and Current Loop tuning wizards that can be used to calculate starting loop gain values.

6.1.1.2.1 Velocity Loop Tuning.

This is done in a similar manner to **many** other servo drives using PID parameters in that the proportional gain parameter #3.10 should be adjusted to give best response to a **small** step change in velocity reference without producing instability. The integral gain, parameter #3.11 should now be adjusted to minimize the overshoot at the top and bottom of the acceleration ramps. If the Integral gain is set too high an oscilloscope trace would show excessive rounding in the corners. The diagrams below show some typical results. Unidrive does have a limitation here in that the scan rate of the analog outputs is a little slow to give meaningful oscilloscope traces for this purpose. A way around this is to use a frequency to voltage converter circuit and connect this to either one of the encoder quadrature outputs or, if a UD52 or UD53 is used it may be connected to one of the quadrature phases from the simulated encoder output of the module.

6.1.1.2.2 Current loop gains.

Normally the default values for parameters #4.13 (current loop proportional gain) and #4.14 (integral gain) will work fine for most motors. Occasionally it may be necessary, particularly with motors having low winding inductance to change these values. For a current loop bandwidth of 500 Hz and minimal overshoot after a step change in current reference use the following formula to calculate proportional gain:

$1800 * L * \text{Drive rated current}$, where L is the motor inductance in Henries.

Note that the motor inductance for a servomotor is half the phase to phase inductance which is normally given in the motor data tables. If 500Hz bandwidth

6. Application Guide

is not satisfactory for your application it is possible to increase the proportional gain calculated above by a factor of 1.5. This will result in a current loop bandwidth of 800Hz but may cause some overshoot in response to a step change in the current reference.

To calculate the Integral gain use the following:

$0.044 * R/L$ where L is the motor inductance and R is the phase to phase resistance.

6.1.1.2.3 Current demand filter time constant.

Occasionally there may be some motor winding noise after tuning the drives. It may be possible to reduce or eliminate this by changing the value of #4.12. This filter will introduce a lag in the speed loop and unless the speed loop gains are reduced may result in some instability. If maximum response is required keep the value of #4.12 to a minimum.

6.1.1.3 Velocity and torque modes.

The default operating mode of the drive as a servo is velocity mode but it is easily possible to run Unidrive in torque mode by changing changing parameter #4.11.

6.1.1.3.1 Velocity mode. Parameter #4.11 = 0

This is used where the position controller outputs a position profile in the form of a velocity reference. In this case the position controller may be external with an analog voltage sent to the drive as the velocity reference or it may be the advanced position controller embedded in the drive co-processor and sending the reference directly to the drive parameters.

In either of these cases there are user adjustable position loop gains. These are tuned after the drive velocity and current loop gains have been set. A typical motion controller may have proportional and feed forward gains. The feedforward gain can normally be set to a predefined value proportional to the gear ratio between the motor and the position controller feed back device (encoder). The proportional gain is then set to achieve minimum following error without inducing instability. .

6.1.1.3.2 Torque mode. Parameter #4.11 =1

Many position controllers are designed to operate using torque reference sent to the drive in the form of an analog voltage. In this is necessary to set the Unidrive to operate in torque mode by setting parameter 4.11 to 1. This eliminates the drive velocity loop completely and simplifies tuning of the application considerably.

The tuning operation now consists simply of setting the position loop gains in the controller. Occasionally it may be necessary to also set the current loop gains in the Unidrive although in most cases the default values are fine.

6.1.1.3.3 Torque control with Speed override. Parameter #4.11 = 2

In this mode the drive will operate in torque mode but with its speed limited by the velocity reference. This mode is of limited use in a servo positioning application.

6. Application Guide

6.1.1.3.4 Speed control with torque feed forward. Parameter #4.11 =4

This mode can be used to provide inertia compensation for example. It is then able to increase torque demand when the system is decelerating a load to stop at a final position. The effect is to greatly reduce overshoot caused by the load inertia. Most external position controllers, such as Axima cannot support this mode as it requires both a velocity and torque reference to be provided. It is fairly simple to implement with the drive co processor advanced position controller however.

6.1.1.4 Effects of drive switching frequency on performance.

Unidrive can be set to operate at switching frequencies of 3, 4.5, 6, 9 and 12 KHz. In servo mode it is normally best to operate at the highest frequency possible. The problem is that the drive output current is de-rated considerably at the higher values and it is normally necessary to compromise.

The switching frequency also has an effect on the co-processor clock speed which will be slower when the frequency is set at 4.5 or 9Khz.

Although the current output is optimized when the switching frequency is set at 3Khz this has been found to suffer from two disadvantages for servo use:

1. The motor can be very noisy particularly when holding a load at zero speed.
2. Due to either cross coupling effects or the fact that the current loop sampling rate is slow the drive can suffer from intermittent OIAC trips.

It is therefore strongly recommended that the Unidrive should be used with the switching frequency set to 6 kHz when in servo mode. This results in the best compromise between available current (torque) and dynamic performance of the drive internal control loops. The drive de-rating at this switching frequency should be taken into account when sizing the application.

6.2 Optimizing the Unidrive for use with an external motion controller.

6.2.1 The motion controller should use plus minus 10 volt analog reference signal as either a velocity or torque demand.

6.2.3 The position feedback input of the controller should be a standard incremental encoder with 5 volt quadrature (ideally RS 422 line receiver inputs). Alternatively a separate feed back device to match the controller could be driven by the motor or the load.

6.2.4 It is strongly recommended that a UD78 high precision analog reference option module should be used in these applications since the standard analog reference input on Unidrive suffers from a 2 to 5 millivolt dead band around zero volts.

6. Application Guide

6.2.5 The servomotor used with the Unidrive should have either incremental encoder or resolver feedback. The UD53 resolver option module does provide a simulated encoder output of up to 4096 ppr resolution. The sin cos encoder is not useful in these applications because:

- a) The quadrature output from the UD52 module is limited to 512 ppr. (When used with the standard sin cos option of Unimotor.
- b) The output is incremental and no marker pulse is provided for homing.

6.3 Position control using a drive Co processor module (UD7x).

This range of modules allow powerful 1.5 axis motion programs to be developed by the user. The program can be written in Control Techniques proprietary **Drive Programming Language (DPL)** which uses the embedded “Advanced Position Controller” or by Use of special motion function blocks.

In either case the Control Techniques SyPT programming tool is used. The actual program development is beyond the scope of this manual but is covered in other Control Techniques publications. Control Techniques also offers training classes in the use of SyPT.

6.3.1 Features of co processor position Control.

The co processor “Advanced Position Controller” and Function Blocks include the following capabilities:

- 6.3.1.1.** Homing cycles to either a marker pulse or switch contact.
- 6.3.1.2.** Simple indexing (move to a position at a single speed)
- 6.3.1.3** Compound indexing string together indexes at different speeds without stopping.
- 6.3.1.4** Digital lock or Electronic Gear box. to Master encoder.
- 6.3.1.5** Cam profiling to a master encoder. Interpolation between cam points can be any of the following types:
 - a) Linear
 - b) Sin 1 and 2
 - c) Cos 1 and 2
 - d) Square.

The profile may be divided into segments using different interpolation types.

- 6.3.1.6.** Absolute positioning using sin cos encoder feed back (4096 motor revolutions) to a resolution of 1,048,576 lines per motor revolution.

Appendix A Unimotor Installation Guide.

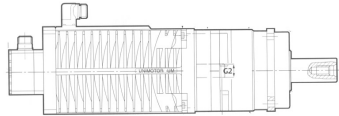

APPLICABILITY
 SIZES: 75; 95; 115; 142; 190
 TYPE: UM; SL; DM; EZ

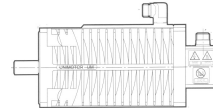

Motor-gearbox

Motor

- All motors are brushless three phase AC motors featuring:-
- Rare earth permanent magnet rotors
 - Sinusoidal waveforms
 - High performance
 - Low inertia
 - Optical encoder or resolver feedback devices
 - Optional internal parking brakes

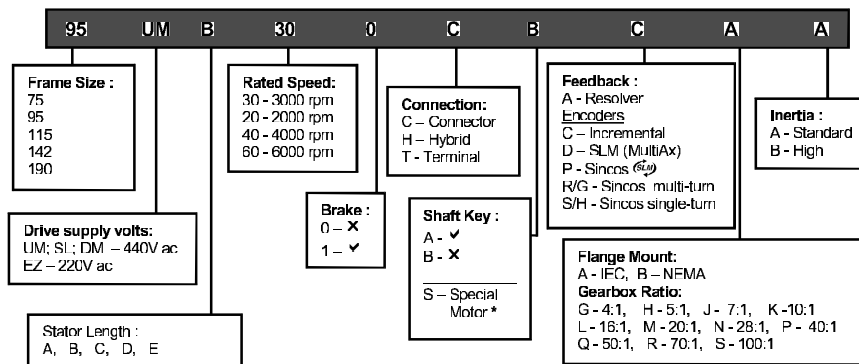

*S = Special motor e.g. 95UMD301CSJH = special type "JH"

Motors & Drives

MOTOR TYPE	DRIVE	DRIVE SUPPLY VOLTS AC
75 - 190 UM	Unidrive	440 V
75 - 190 SL	MultiAx $\frac{60}{p}$	440 V
75 - 190 SL	M'Ax $\frac{60}{p}$	440 V
75 - 142 DM	Digitax	440 V
75 - 115 EZ	Epsilon & EN series	220 V

Transportation



All servomotors are inspected before leaving the factory and are packed in perfect condition. Upon receipt, please check the packaging for damage. If the package is damaged, notify the carrier before signing for the motor.

Handling



NO lift at feedback cover!

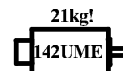

142UM motor, mass - up to 21kg.



190UM motor, mass - up to 48kg

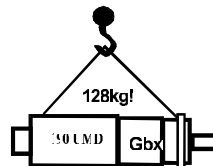

Motor-gearboxes mass = up to 128kg

Motor help line: Tech@ctdynamics.com	CTD sales: Sales@ctdynamics.com	www.ctdynamics.com
---	---	--

Appendix A Unimotor Installation Guide.



Storage

Store the motor only in an enclosed, dry, ventilated and vibration-free place. Any damage caused by incorrect storage or handling is not covered by the defects warranty.

Safety

IMPORTANT!  READ INSTRUCTIONS!

POWERFUL MOTORS!

- 700V DC SWITCHED MODE
- REMOTELY CONTROLLED
- HIGH ACCELERATION
- QUALIFIED INSTALLERS ONLY!

 KEEP HANDS AND CLOTHING CLEAR!

 CLAMP MOTOR BEFORE OPERATING!

 INCORRECT DRIVE SET-UP CAN DESTROY THE MOTOR!

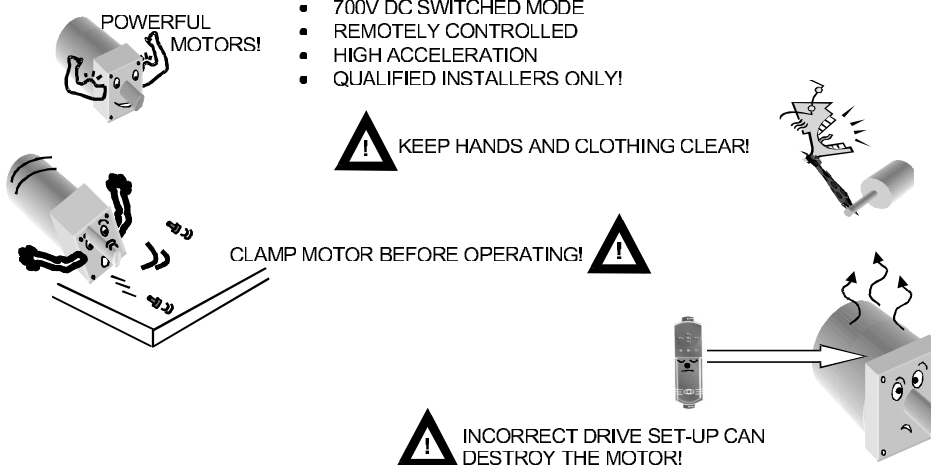

Installation - mechanical

For full details, refer to motor manual.



700V DC - SWITCH OFF POWER!

1. To determine if a phase test is required, refer to "Commutation" on Page 8.
2. If a phase test is required, it must be performed with no mechanical load on the motor.
Note that with a fitted gearbox, a phase-offset test may not be suitable, in this case use offset value as shown on motor offset label.

Where applicable, phase offset values are printed on a label at the encoder cover and phase offset values can be entered directly to the Unidrive. In this way, the phase test is rendered unnecessary.

3. If a phase test is not required, mount the motor to the machine using high tensile bolts.

Motor help line: Tech@ctdynamics.com	CTD sales: Sales@ctdynamics.com	www.ctdynamics.com
---	---	--

Appendix A Unimotor Installation Guide.



Installation – mechanical (continued)

Fixing Dimensions

Frame	Register Ø (mm)	Pitch Circle Dia	Fixing Holes Ø (mm)	Preferred Pitch	Thread Pitch	Tightening Torque
75	60.0 (J6)	75	5.8 (H14)	M5	0.8	5.0
95	80.0 (J6)	100	7.0 (H14)	M6	1.0	8.4
115	95.0 (J6)	115	10.0 (H14)	M8	1.25	20.0
142	130.0 (J6)	165	12.0 (H14)	M10	1.50	41.0
190	180.0 (J6)	215	14.5 (H14)	M12	1.75	71.0

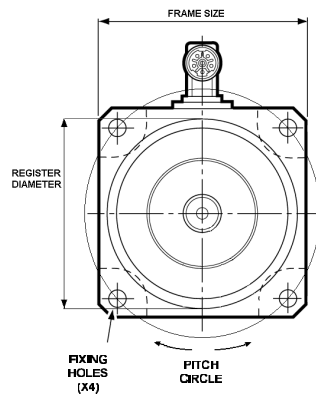

If the motor rating label is obscured after mounting, affix the duplicate rating label (supplied) to a visible part of the motor or machine.

Bolt the motor flange to a substantial steel or aluminium plate 6 -15mm thick. Correctly locate registration spigot.

If the thermal path via the front flange is impeded, de-rate the motor performance by up to 10%.

The motor shaft should be correctly aligned with the driven load.

Allow sufficient space around the motor for the free circulation of air. Ambient temperatures of between 0°C and 40°C are acceptable.

Hot Surface

Surface temperature may exceed 100°C. Keep low temperature rated materials away from surface.

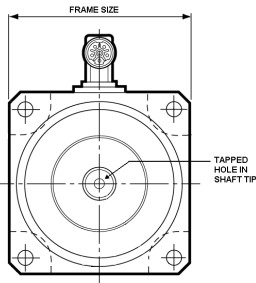
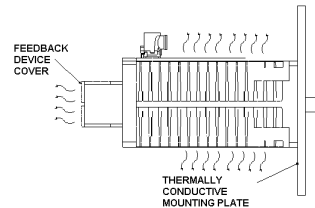
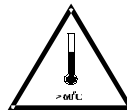

Shaft Connection

Ensure the output key is correctly seated before mounting keyed components to the shaft.



Do NOT use a hammer to fit components to the shaft. This will damage the motor bearings and the encoder.

Use bolt & washer in shaft thread to draw component hub against shaft step.

Remove components using a suitable gear puller.

Frame Size	Tapped Hole Ø (mm)
55A-C	M4 x 10.0
75A	M4 x 10.0/12.0
75B-95A	M5 x 12.5/14.5
95B-115C	M6 x 16.0/18.0
115D-142F	M8 x 19.0/21.0
190A-D	M12 x 28.0

Motor help line: Tech@ctdynamics.com	CTD sales: Sales@ctdynamics.com	www.ctdynamics.com
---	---	--

Appendix A Unimotor Installation Guide.





CAUTION! Output key can fly off

Remove output key
Do NOT run keyed motors when no shaft components are fitted.
Remove the output key first to prevent injury.

Installation - Electrical



DO NOT CONNECT OR DISCONNECT WITH POWER ON!

Switch off the drive for at least two minutes before connecting or disconnecting the motor. Refer to the drive documentation. The motor contains a permanent magnet rotor. As a result, a voltage is generated at the motor terminals when the rotor is turned. If the motor is back-driven for any reason care must be exercised to avoid electric shocks.

POWER CONNECTIONS

Earth Connections

The motor operates at switching voltages of up to 700V DC, even when stationary.

It is essential that the safety earth be connected via the power cable to the supply safety earth point.

It is good practice to connect an earth bond strap from the machine to the motor body. Fit the strap to the front flange of the motor such that it will not interfere with mounting alignment.

Power connections to Plug or Hybrid / Terminal box

Hybrid or Terminal boxes are denoted in the motor type number - by an H (Hybrid) or T (Terminal),

e.g:

Function	Plug Pin marking	Hybrid terminal marking
Phase U	1	U
Phase V	2	V
Phase W	4	W
Safety Earth	3	
Brake 24VDC	5	+
Brake return	6	-

142XXE301TAAAA Terminal box – box has two glands for power and resolver cables.

142XXE301HAAAA Hybrid box – box has one gland for power cable, plus a signal receptacle on motor end cover.

142XXE301CAAAA Connector receptacles for both signal and power – no box or glands.

For motors with connections made via a terminal or hybrid connection box, ensure that a good seal is made between cables and the cable glands. Connect power cable earth to box earth screw.

Connector Orientation

The power receptacle on most motors can be rotated, so that the desired cable outlet direction can be easily achieved.

90 ° elbow signal plugs are available on cable assemblies and as connector kits (see later).

Motor help line: Tech@ctdynamics.com	CTD sales: Sales@ctdynamics.com	www.ctdynamics.com
---	---	--

Appendix A Unimotor Installation Guide.



Signal Cable Connections

RESOLVER

Signal Connector Resolver (12 pin)	
Size 1 (All Frames)	
Function	Pin
Excitation (High)	1
Excitation (Low)	2
Cosine (High)	3
Cosine (Low)	4
Sin (High)	5
Sin (Low)	6
Thermistor - PTC	7
Thermistor - PTC Return	8
not used	9
not used	10
not used	11
not used	12
Screen	Shell

Resolver gives absolute position information (non-volatile).

Resolver requires UD53 Small Options Module for Unidrive.

UM, DM & EZ motors

It is essential to make signal connections exactly as specified otherwise direction sense and commutation will be incorrect.

ENCODER

Signal Connector Encoder (17 pin)	
Size 1 (All Frames)	
Function	Pin
Thermistor - PTC	1
Thermistor - PTC Return	2
Screen	Shell
S1	4
S1 Inverse	5
S2	6
S2 Inverse	7
S3	8
S3 Inverse	9
Channel A	10
Index	11
Index Inverse	12
Channel A Inverse	13
Channel B	14
Channel B Inverse	15
+5 V DC	16
0 V	17



Signal Connector SLM (5 pin)	
Amphenol C91D	
Function	Pin
Comms inverse	1
0V	2
+24V	3
Screen (0V)	4
Comms	5
Screen	Shell

SL Motors

Cable length should not exceed 50m.

SL encoder contains motor map.

M'Ax and electronics offers thermal protection without motor thermistors.

Note: Screen is connected to plug body on connectors detailed above.

Motor help line: Tech@ctdynamics.com	CTD sales: Sales@ctdynamics.com	www.ctdynamics.com
---	---	--

Appendix A Unimotor Installation Guide.



SINCOS SIGNAL CONNECTION

Signal Connector Sincos (12 way) size1 (all frames)	
Function	Pin
Ref Cosine	1
+RS485	2
- RS485	3
Cosine	4
Sine	5
Ref Sine	6
Thermistor	7
Thermistor return	8
Screen	9
0V	10
not connected	11
8V dc	12

UM motors with Sincos Feedback

For SCS60 & SCM60 absolute encoders.

UD52 interface required for Unidrive.

Suitable for both single and multi-turn versions.

Isolate screen from shell.

Note: Screen is isolated from plug body on this connector.

Connector Kits



For those who wish to manufacture their own cables, connector kits, crimp tools and insertion/removal tools may be purchased.

Kits consist of plug shell, plus crimp socket contacts to match, including brake socket contacts for power plugs.

Power plugs, cable end kits

KIT No.	DESCRIPTION	USED ON
IM/0039/KI	6 WAY SIZE 1.0" POWER PLUG KIT 1-4mm ²	75-142 UM; DM; EZ; SL
IM/0053/KI	6 WAY SIZE 1.5" POWER PLUG KIT, 1.5 –10 mm ²	190 UM; DM; FZ; SI
IM/0054/KI	6 WAY SIZE 1.5" POWER PLUG KIT, 6.0 –16 mm ²	190 UM; FZ; SI

Signal plugs, cable end kits

KIT No.	DESCRIPTION	USED ON
IM/0022/KI	17 WAY SIGNAL PLUG KIT	Incremental
IM/0023/KI	12 WAY SIGNAL PLUG KIT	Resolver & Sincos
IM/0033/KI/02	17 WAY SIGNAL 90 deg. FI BOW PLUG KIT	Incremental
IM/0033/KI/01	12 WAY SIGNAL 90 deg. FI BOW PLUG KIT	Resolver & Sincos
IM/0024/KI	5 WAY  SL PLUG KIT (Amphenol)	

Power & Signal Plugs, cable end kits

KIT No.	DESCRIPTION	USED ON
IM/0011/KI	6 WAY SIZE 1.0" POWER PLUG & 12 WAY SIGNAL	Resolver & Sincos, UM; DM
IM/0012/KI	6 WAY SIZE 1.0" POWER PLUG & 17 WAY SIGNAL	Incremental, UM; EZ

Ready Made Cables

Ready made power and signal cables of all types can be supplied to the nearest whole metre. Contact your local Drive centre for details.

Motor help line: Tech@ctdynamics.com	CTD sales: Sales@ctdynamics.com	www.ctdynamics.com
---	---	--

Appendix A Unimotor Installation Guide.



Commutation

For the motor to operate correctly, it is essential to set correct commutation at both drive and feedback device. If drive commutation is set incorrectly, motor may be grossly inefficient and permanent damage may occur.

For 'plug and play drives' such as Epsilon / EN (selected motors only) and M'Ax drives, commutation setting will be automatic. For all other drives, the number of poles must be set.

UM/EZ motors fitted with resolver feedback have preset commutation to match Digitax Unidrive set with default commutation (zero phase offset).

EZ motors with encoders have commutation correctly set to match motor maps in Epsilon drives without offset correction. Sincos motors have commutation set to zero, fully implemented March 2001.

Due to certain constraints, UM motors with encoder feedback may not have sufficiently accurate pre-set zero commutation. This is a temporary situation, and for these motors a Unidrive phase offset correction value is printed on a label on the motor's encoder cover. This may be entered directly into the Unidrive.



Auto-Phase Offset

For incremental encoder feedback the Unidrive offers a Phasing test, (parameter #03.25). This will enable the user to automatically set commutation offset without the use of the offset correction figure. It is essential that this test is performed with no mechanical load on the motor. Where this is not practical, use the offset value as printed on the label of the feedback cover. This number can be entered directly into the Unidrive Phase Offset value, parameter #03.28. Once entered, the offset will remain until the parameter is changed. Unidrive will retain this number even when powered off. Commutation will then be correctly set.



Motor Rating & Thermal Protection

Drive parameters must be set to provide the motor with adequate protection.
Set the maximum continuous motor current as per the motor stall current.
Set peak current not greater than 300% of stall. (N.B. Peak current must not increase when motor is forced cooled.)

Always connect the thermistor wires to the drive sensor circuits (M'Ax & MultiAx do not require thermistor protection).



Thermal Time Constant

Incorrect settings of the current and thermal time constant could cause the motor to overheat and invalidate the warranty. Note that the thermal time constant referred to here relates to the thermal time constant of the windings for short term motor overdrive conditions and NOT the thermal time constant of the complete motor that is often listed in performance data.

Motor winding thermal time constants are given below.

Motor Type	75A	75B	75C	75D	95A	95B	95C	95D	95E	115A	115B	115C	115D	115E	142A	142B	142C	142D	142E	190A	190B	190C	190D
Time Constant (s)	90	102	120	131	91	116	129	145	166	52	77	86	97	102	75	98	119	133	138	112	149	188	195

Other parameters usually required for drive settings are encoder count, number of motor poles, maximum speed gain (PID) settings for current, speed and position loops.

Motor help line: Tech@ctdynamics.com	CTD sales: Sales@ctdynamics.com	www.ctdynamics.com
---	---	--

Appendix A Unimotor Installation Guide.



Servo Stability

Servo instability is a common cause of motor overheating or over-current trips. Servo instability can be seen with an oscilloscope at speed monitor points or by careful audible checks at the motor (e.g. with a stethoscope or similar).

Always adjust drive PID (Proportional, Integral and Differential Gains) to give adequate stability margins to allow for changes of circumstances such as motor function (accelerate, run, stationary torque, hold position), load, temperature, etc. Consult your drive supplier for further information.

M'Ax, MultiAx, Epsilon and EN drives have plug and play motor maps for quick start set-up, but final adjustments may be required for optimum set up of any particular servo mechanism.

Parking brakes

Brakes are 24V DC, and are not polarity conscious. It is recommended that a reverse polarity diode be fitted across the brake at the drive-end relay contacts or semi-conductor device, together with appropriate R/C (Resistor/Capacitor) noise suppression.

To release the brake, the coil must be energised.



The brake can only survive a limited number of emergency braking operations and should not be used for repeated dynamic braking.

DO NOT APPLY BRAKE WHILE THE SHAFT IS ROTATING, EXCEPT IN AN EMERGENCY.

Servicing



The motor surface only should be kept clean with a damp cloth to maintain effective cooling.

Do not use degreasing agents in the vicinity of the bearings

Except for cleaning, no routine maintenance is required. Except for in special circumstances periodic bearing changes (dependent on application) that should be carried out by CT Dynamics or an approved repair centre.

Only CT Dynamics or an approved repair centre may make repairs, contact your local Drive Centre for details.

Related Products

Cable Assemblies

Cable assemblies simplify motor connection and reduce installation time. Made to order in lengths of up to 100 metres, they have a PUR sheath for high resistance to oil, grease and solvents and have excellent dynamic performance. VDE approved.

Fan Cowling Kits

Fan cowlings force cool air through the fins on the motor housing to increase continuous torque output by up to 87%. Available to fit all frame sizes, the units may be retrofitted to maximise power density.

Motor help line: Tech@ctdynamics.com	CTD sales: Sales@ctdynamics.com	www.ctdynamics.com
---	---	--