

**INSTRUCTION MANUAL
ELECTRONIC TOTAL STATION**

GTS-750 SERIES

GTS-751
GTS-752
GTS-753
GTS-755

PULSE TOTAL STATION

GPT-7500 SERIES

GPT-7501
GPT-7502
GPT-7503
GPT-7505

FOREWORD

Thank you for purchasing the TOPCON Total Station GTS-750/GPT-7500 series. For the best performance of the instruments, please carefully read these instructions and keep them in a convenient location for future reference.



This instruction manual explains the basic operation of this instrument. Regarding the Program Mode, please see the supplementary manual, "Program Mode."

General Handling Precautions

Before starting work or operation, be sure to check that the instrument is functioning correctly with normal performance.

Do not aim the instrument directly into the sun

Aiming the instrument directly into the sun can result in serious damage to the eyes. Damage to the instrument could also result from exposing the instrument's objective lens to direct sunlight. The use of a solar filter is suggested to alleviate this problem.

Setting the instrument on a tripod

When mounting the instrument on a tripod, use a wooden tripod when possible. The vibrations that may occur when using a metallic tripod can effect the measuring precision.

Installing the tribrach

If the tribrach is installed incorrectly, the measuring precision could be effected. Occasionally check the adjusting screws on the tribrach. Make sure the base fixing lever is locked and the base fixing screws are tightened.

Guarding the instrument against shocks

When transporting the instrument, provide some protection to minimize risk of shocks. Heavy shocks may cause the measurement to be faulty.

Carrying the instrument

Always carry the instrument by its handgrip.

Exposing the instrument to extreme heat.

Do not leave the instrument in extreme heat for longer than necessary. It could adversely affect its performance.

Sudden changes of temperature

Any sudden change of temperature to the instrument or prism may result in a reduction of measuring distance range, i.e when taking the instrument out from a heated vehicle. Let instrument acclimate itself to ambient temperature.

Battery level check

Confirm battery level remaining before operating.

Memory back up

The back-up battery built in the instrument needs to be charged approximately 24hrs. before using it for the first time after purchase. Connect the fully charged battery to the instrument in order to charge the back-up battery.

Taking the battery out

Leaving the instrument without the battery for more than an hour will cause the memorized data to be lost, due to low voltage of the back-up battery. Connect the battery as soon as possible or execute RAM back-up.

No responsibility

TOPCON Corporation has no responsibility for loss of data stored in the memory in case unexpected accidents.

Battery cover

Completely close the battery cover before using the GTS-750/GPT-7500. If the battery cover is not completely closed, the GTS-750/GPT-7500 will not operate normally, regardless of whether the battery or the external power source is used.

If the battery cover is opened while the GTS-750/GPT-7500 is in operation, operation will automatically be suspended.

Power OFF

When turning off the power, be sure to turn off the GTS-750/GPT-7500's power switch.

Do not turn off the power by removing the battery.

Before removing the battery, press the power switch and confirm that the power is off. Then remove the battery.

While using the external power source, do not turn off the GTS-750/GPT-7500 with the switch on the external power source.

If the above-mentioned operating procedure is not followed, then, the next time that power is turned on, it will be necessary to reboot the GTS-750/GPT-7500.

External power source



Use only recommended batteries or external power source. Use of batteries or an external power source not recommended by us may result in equipment failure.

(For further information see Chapter 13 "BATTERY SYSTEM" .)

Display for Safe Use

In order to encourage the safe use of products and prevent any danger to the operator and others or damage to properties, important warnings are put on the products and inserted in the instruction manuals.

We suggest that everyone understand the meaning of the following displays and icons before reading the "Safety Cautions" and text.

Display	Meaning
 WARNING	Ignoring or disregard of this display may lead to the danger of death or serious injury.
 CAUTION	Ignoring or disregard of this display may lead to personal injury or physical damage.

•Injury refers to hurt, burn, electric shock, etc.

•Physical damage refers to extensive damage to buildings or equipment and furniture.

Safety Cautions

 WARNING
<p>•There is a risk of fire, electric shock or physical harm if you attempt to disassemble or repair the instrument yourself. This is only to be carried out by TOPCON or an authorized dealer, only!</p>
<p>•Cause eye injury or blindness. Do not look at the sun through a telescope.</p>
<p>•Laser beams can be dangerous, and can cause eye injury's if used incorrectly. Never attempt to repair the instrument yourself.</p>
<p>•Cause eye injury or blindness. Do not stare into beam.</p>
<p>•High temperature may cause fire. Do not cover the charger while it is charging.</p>
<p>•Risk of fire or electric shock. Do not use damaged power cable, plug and socket.</p>
<p>•Risk of fire or electric shock. Do not use a wet battery or charger.</p>
<p>•May ignite explosively. Never use an instrument near flammable gas, liquid matter, and do not use in a coal mine.</p>
<p>•Battery can cause explosion or injury. Do not dispose in fire or heat.</p>
<p>•Risk of fire or electric shock. Do not use any power voltage except the one given on manufacturers instructions.</p>
<p>•To reduce the risk of hazards, use only CSA/UL certified power supply cord set, cord is Type SPT-2 or heavier, minimum No.18 AWG copper, one end is provided with a moulded-on male attachment plug cap (with a specified NEMA configuration), and the other end is provided with a moulded-on female connector body (with a specified IEC non-industrial type configuration).</p>
<p>•Battery can cause outbreak of fire. Do not use any other type of charger other than the one specified.</p>
<p>•Risk of fire. Do not use any other power cable other than the one specified.</p>
<p>•The short circuit of a battery can cause a fire. Do not short circuit battery when storing it.</p>

CAUTION

- Do not connect or disconnect equipment with wet hands, you are at risk of electric shocks if you do!
- Use of controls or adjustment or performance of procedures other than those specified herein may result in hazardous radiation exposure.
- Let the laser beam reach the aimed object or the target without anybody else in the laser beam path. In case you operate laser beam open, avoid radiating laser beam to the height of man's head. It is quite possible for the beam to enter into one's eyes, and it is possible to lose visual sight temporarily, and lose one's caution and awareness of other dangers - avoid glaring beam.
- Risk of injury by overturn the carrying case.
Do not stand or sit on the carrying cases.
- Please note that the tips of tripod can be hazardous, be aware of this when setting up or carrying the tripod.
- Risk of injury by falling down the instrument or case.
Do not use a carrying case with a damaged which belts, grips or latches .
- Do not allow skin or clothing to come into contact with acid from the batteries, if this does occur then wash off with copious amounts of water and seek medical advice.
- A plumb bob can cause an injury to a person if used incorrectly.
- It could be dangerous if the instrument falls over, please ensure you attach a handle to the instrument securely.
- Ensure that you mount the tribrach correctly, failing to do so may result in injury if the tribrach were to fall over.
- It could be dangerous if the instrument falls over, please check that you fix the instrument to the tripod correctly.
- Risk of injury by falling down a tripod and an instrument.
Always check that the screws of tripod are tightened.

User

1)This product is for professional use only!

The user is required to be a qualified surveyor or have a good knowledge of surveying, in order to understand the user and safety instructions, before operating, inspecting or adjusting.

2)Wear the required protectors (safety shoes, helmet, etc.) when operating.

Exceptions from Responsibility

- 1)The user of this product is expected to follow all operating instructions and make periodic checks of the product's performance.
- 2)The manufacturer, or its representatives, assumes no responsibility for results of a faulty or intentional usage or misuse including any direct, indirect, consequential damage, and loss of profits.
- 3)The manufacturer, or its representatives, assumes no responsibility for consequential damage, and loss of profits by any disaster, (an earthquake, storms, floods etc.).
A fire, accident, or an act of a third party and/or a usage any other usual conditions.
- 4)The manufacturer, or its representatives, assumes no responsibility for any damage, and loss of profits due to a change of data, loss of data, an interruption of business etc., caused by using the product or an unusable product.
- 5)The manufacturer, or its representatives, assumes no responsibility for any damage, and loss of profits caused by usage except for explained in the user manual.
- 6)The manufacturer, or its representatives, assumes no responsibility for damage caused by wrong movement, or action due to connecting with other products.

Laser Safety

- **Distance Measurement**

GPT-7500 series uses the invisible laser beam. The GPT-7500 series are manufactured and sold in accordance with "Performance Standards for Light-Emitting Products" (FDA/BRH 21 CFR 1040) or "Radiation Safety of Laser Products, Equipment Classification, Requirements and User's Guide" (IEC Publication 825) provided on the safety standard for laser beam.

As per the said standard, the GPT-7500 series is classified as "Class 1 (I) Laser Products".

In case of any failure, do not disassemble the instrument. Contact TOPCON or your TOPCON dealer.

- **Laser pointer**

GPT-7500 series laser pointer use the visible laser beam. The GPT-7500 series laser pointer are manufactured and sold in accordance with "Performance Standards for Light-Emitting Products" (FDA/BRH 21 CFR 1040) or "Radiation Safety of Laser Products, Equipment Classification, Requirements and User's Guide" (IEC Publication 825) provided on the safety standard for laser beam.

In case of any failure, do not disassemble the instrument. Contact TOPCON or your TOPCON dealer.

Laser class of each mode is as follows.

Mode	Laser class
Distance measurement	Class 1 (CLASS I)
Laser pointer	Class 2 (CLASS II)

Labels

Find the labels which describes the caution and safety about the laser beam as follows in GPT-7500 series.

We request you to replace it one anytime the caution labels are damaged or lost and paste a new one at the same place. You can get the labels from Topcon or your dealer.

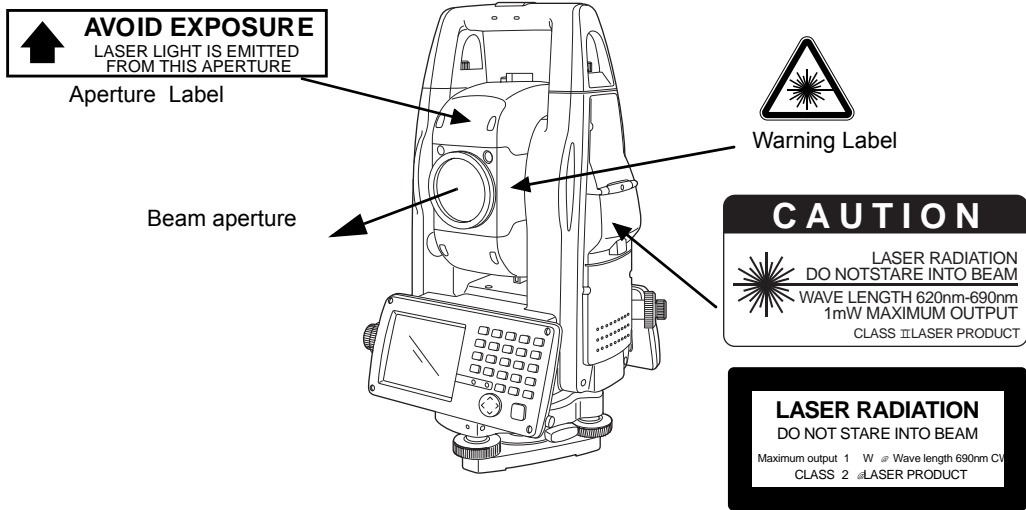

Each label is differed by the market.

Symbol Mark while the Laser is Emitting.

These symbol marks will come on while the laser is working

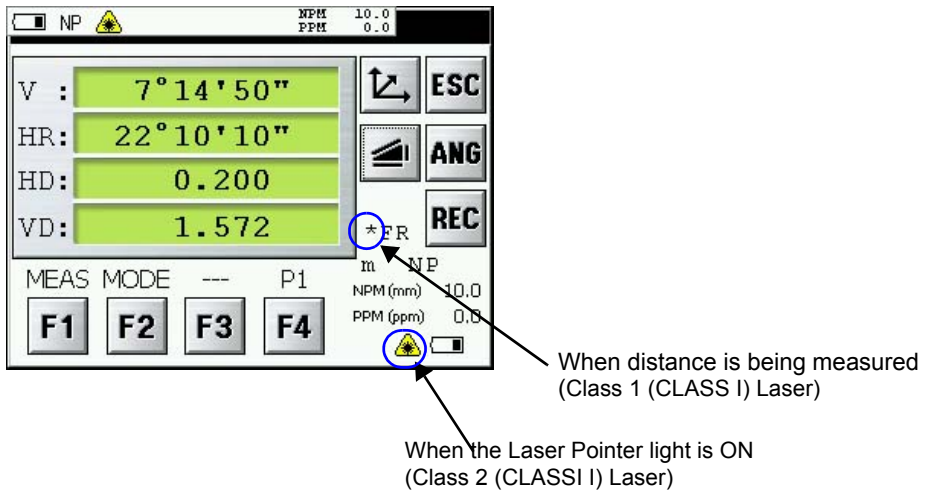

Contents

FOREWORD	1
General Handling Precautions	2
Display for Safe Use	3
Safety Cautions	3
User	4
Exceptions from Responsibility	4
Laser Safety	5
Labels	5
Symbol Mark while the Laser is Emitting	6
Contents	7
1 NOMENCLATURE AND FUNCTIONS	10
1.1 Nomenclature	10
1.2 Display	12
1.2.1 Main Menu Contains	12
1.2.2 Measurement Menu	13
1.2.3 Display Marks	13
1.2.4 Display keys	14
1.2.5 Shortcut Keys	14
1.3 Backlight, Key Light Adjustment	15
1.3.1 How to Adjust Reducing Time of Backlight	15
1.3.2 Adjust the Backlight Brightness by Manual	17
1.3.3 Selecting the Automatic Lighting Option	18
1.3.4 Selecting the Key Light Option	19
1.4 RAM Data Backup	20
1.4.1 Execute the Backup Function	20
1.4.2 Set the Automatic Backup for Every Suspension	22
1.4.3 Set the Restoration Disabled after Hardware Reset	22
1.5 Hardware Reset	23
1.6 Cover Sensor	23
1.7 Touch Panel Calibration	24
1.8 Operating Panel Key	26
1.8.1 Operating Key	26
1.9 Power OFF	27
1.10 Function Key (Soft Key)	28
1.11 Star Key Mode	30
1.11.1 Switching Measurement Distance Modes	34
1.11.2 Setting by Using Star Key	35
1.12 Auto Power Off	36
1.13 Using the USB Port	38
2 PREPARATION FOR MEASUREMENT	39
2.1 Power Connection	39
2.2 Setting Instrument Up For Measurement	40
2.3 Power Switch Key ON	41
2.4 Battery Power Remaining Display	42
2.5 Vertical and Horizontal Angle Tilt Correction	43
2.5.1 Setting Tilt Correction by Soft Key	44
2.6 Compensation of Systematic Error of Instrument	45
2.7 How to Enter Numerals and Alphabet Letters	46
2.8 Data Memory Card	50
2.9 Active Sync	51
2.9.1 Getting Connected	51
3 STANDARD MEASUREMENT MODE	52
3.1 Angle Measurement	52
3.1.1 Measuring Horizontal Angle Right and Vertical Angle	52
3.1.2 Switching Horizontal Angle Right/Left	53
3.1.3 Measuring from the Required Horizontal Angle	54
3.1.4 Vertical Angle Percent Grade(%) Mode	55
3.2 Distance Measurement	56
3.2.1 Setting of the Atmospheric Correction	58
3.2.2 Setting of the Correction for Prism Constant	58

3.2.3	Setting Measurement distance range of Non-prism long mode	58
3.2.4	Distance Measurement (Continuous Measurement)	60
3.2.5	Distance Measurement (Single/N-times Measurement)	61
3.2.6	Fine / Coarse / Tracking Measuring Mode	62
3.2.7	Stake Out (S.O)	64
3.3	Coordinate Measurement	66
3.3.1	Setting Coordinate Values of Occupied Point	66
3.3.2	Setting of the Instrument Height / Reflector(Prism) Height	68
3.3.3	Execution of Coordinate Measuring	69
3.4	Data Output	70
3.5	Data Output by [REC] Key	71
4	PROGRAM MODE	72
4.1	Setting a Direction Angle for Backsight Orientation(BS)	73
4.2	Remote Elevation Measurement (REM)	75
4.3	Missing Line Measurement (MLM)	78
4.4	Repetition Angle Measurement (REP)	80
5	PARAMETERS SETTING MODE	82
5.1	Parameter Setting Options	83
5.1.1	Measurement	83
5.1.2	Communication	84
5.1.3	Value Input	84
5.1.4	Unit	84
5.2	Setting Parameters	85
6	CHECK AND ADJUSTMENT	86
6.1	Checking and Adjusting of Instrument Constant	86
6.1.1	Checking of the accuracy of the non-prism mode / non-prism long mode	86
6.2	Checking the Optical Axis	87
6.2.1	Checking the optical axis of EDM and theodolite	87
6.2.2	Checking the optical axis of Laser pointer	92
6.3	Checking/Adjusting the Theodolite Functions	94
6.3.1	Checking /Adjusting the Plate Level	95
6.3.2	Checking /Adjusting the Circular Level	95
6.3.3	Adjustment of the Vertical Cross-hair	96
6.3.4	Collimation of the Instrument	97
6.3.5	Checking / Adjusting the Optical Plummet Telescope	98
6.3.6	Adjustment of Vertical Angle 0 Datum	99
6.4	How to Set the Instrument Constant Value	100
6.5	Compensation Systematic Error of Instrument	101
6.5.1	Adjustment of Compensation Systematic Error of Instrument	101
6.5.2	Showing Compensation Systematic Error of Instrument	103
7	SETTING THE PRISM / NON-PRISM CONSTANT VALUE	104
8	SETTING ATMOSPHERIC CORRECTION	105
8.1	Calculation of Atmospheric Correction	105
8.2	Setting of Atmospheric Correction Value	106
9	CORRECTION FOR REFRACTION AND EARTH CURVATURE	111
9.1	Distance Calculation Formula	111
10	POWER SOURCE AND CHARGING	112
10.1	On-board Battery BT-65Q	112
11	DETACH/ATTACH OF TRIBRACH	114
12	SPECIAL ACCESSORIES	115
13	BATTERY SYSTEM	117
14	PRISM SYSTEM	118
15	PRECAUTIONS	119
16	MESSAGE/ERROR DISPLAYS	120
16.1	Message	120
16.2	Error	121
17	SPECIFICATIONS	122

18 APPENDIX	127
Dual Axis Compensation	127
19 INDEX	129

1 NOMENCLATURE AND FUNCTIONS

1.1 Nomenclature

The GTS-755 and GPT-7505 are one-display models.

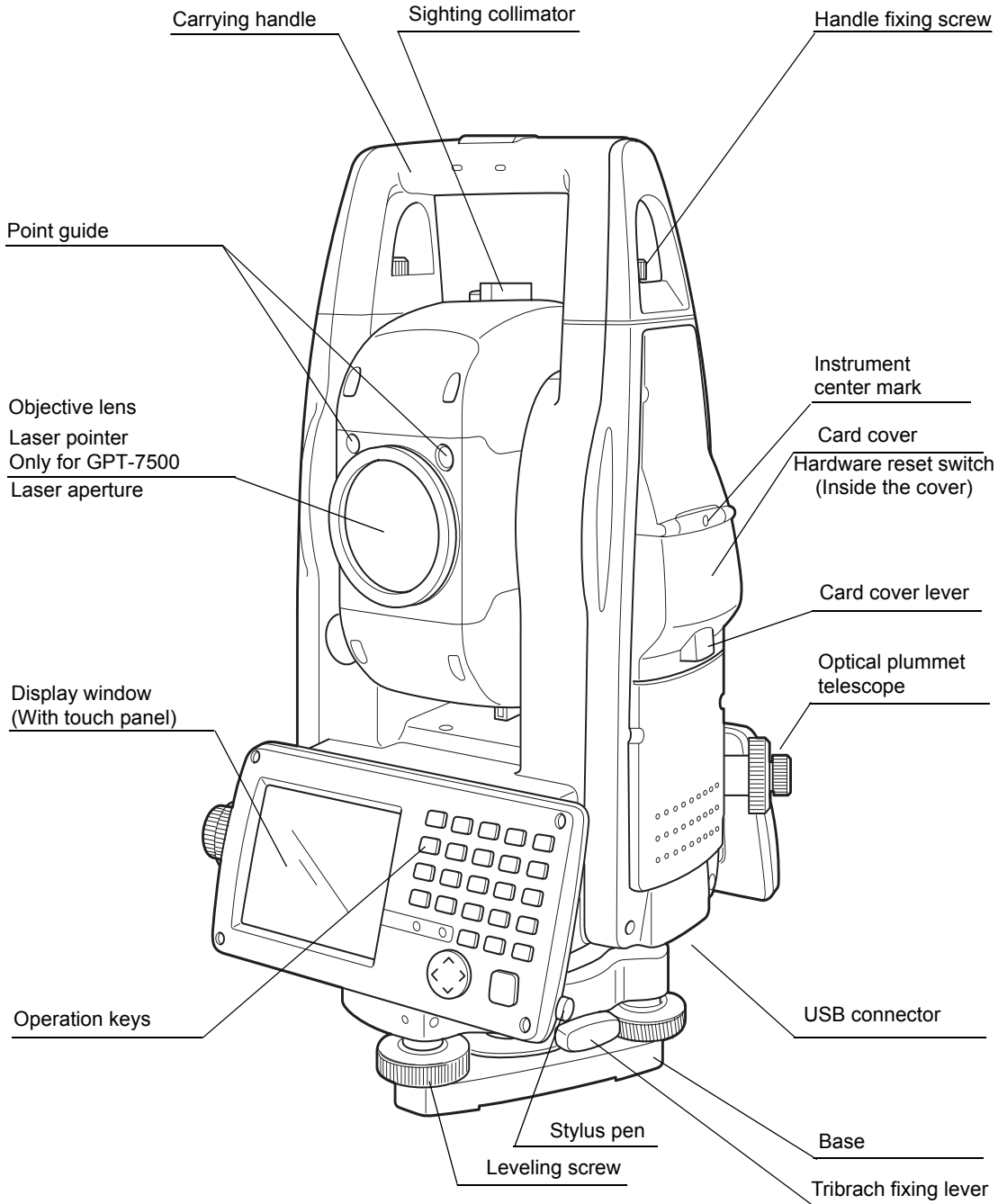

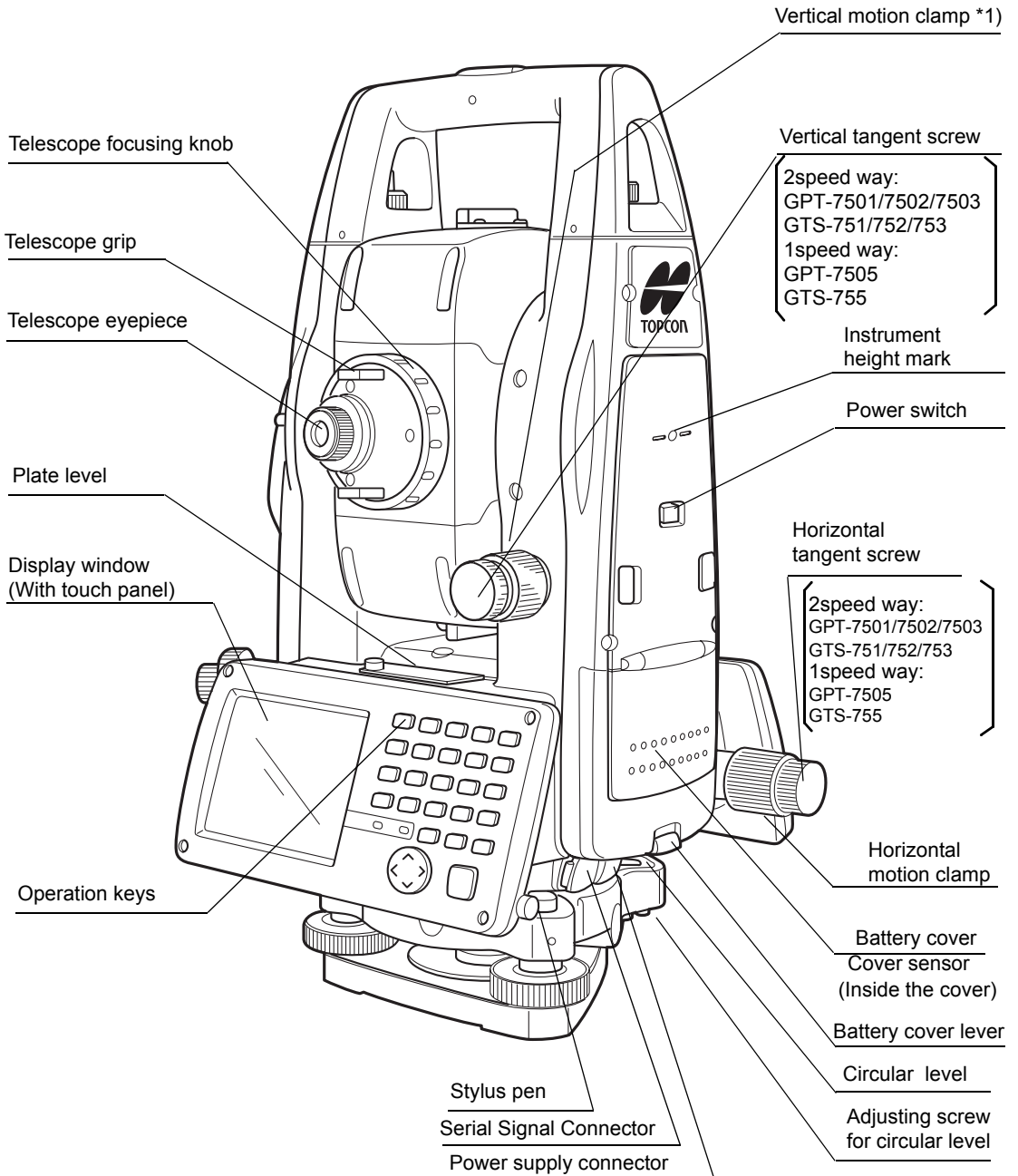

*1) The position of vertical motion clamp and tangent screw will differ depend on the markets.

1.2 Display

1.2.1 Main Menu Contains

The main menu contains as following items.

Select the menu by pressing icons.

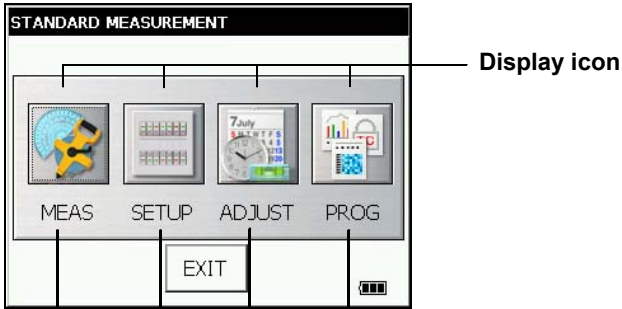

PROGRAM MODE

- Setting a direction angle for backsight orientation
- Remote elevation measurement
- Missing line measurement
- Repetition angle measurement
(see Chapter 4 "PROGRAM MODE" .)

ADJUSTMENT MODE

This mode is used for checking and adjustment.

- Error of vertical angle 0 datum
- Setting instrument constant value
- Compensation systematic error of Instrument
- Checking the optical axis of EDM
(see Chapter 6 "CHECK AND ADJUSTMENT" .)

PARAMETERS SETTING MODE

This mode is used for follows

- Setting measurement
- Setting communication
- Value input
- Setting unit

The PARAMETERS SETTING MODE settled is memorized even power is off.

(see Chapter 5 "PARAMETERS SETTING MODE" .)

STANDARD MEASUREMENT MODE

This mode is used for follows

- Angle measurement
- Distance measurement
- Coordinate measurement

(see Chapter 3 "STANDARD MEASUREMENT MODE" .)

1.2.2 Measurement Menu

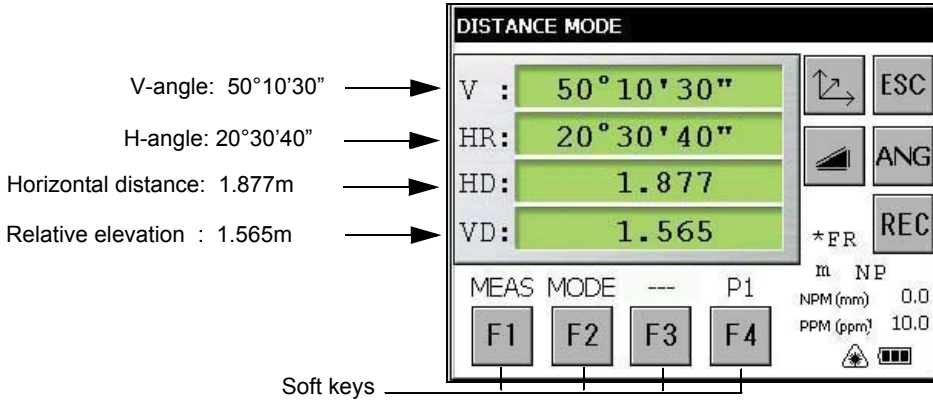

Example:Distance Mode



1.2.3 Display Marks

Display	Contents	Display	Contents
V	V-angle	m	Meter unit
V%	Percent grade	ft	Feet unit
HR	H-angle right	F	Fine mode
HL	H-angle left	C	Coarse mode
HD	Horizontal distance	c	Coarse 10mm mode
VD	Relative elevation	R	Repeat measurement
SD	Slope distance	S	Single measurement
N	N coordinate	N	N-times measurement
E	E coordinate	PPM	Atmospheric correction value
Z	Z coordinate	PSM	Prism constant value
*	EDM working	NPM	Non-Prism constant value
	Battery Level Indicator Refer to see Chapter 2.4 "Battery Power Remaining Display" . for further information.	NP	Non-prism mode
	Laser emitting mark	LNP	Non-prism long mode
	Setting Non-prism long range		

1.2.4 Display keys

Keys	Name of Key	Function
F1~F4	Soft key	Functions are according to the displayed message.
ESC	Escape key	Returning to the previous mode or display.
ANG	Angle measuring key	To be angle measuring mode.
	Distance measuring key	To be distance measuring mode.
	Coordinate measuring key	To be coordinate measuring mode.
REC	REC key	Result of measurement is transferred.

1.2.5 Shortcut Keys

Software Reset	[Shift]+[Func]+[ESC]
Windows Start Menu	[Ctrl]+[ESC]
Shortcut Commands	Continue tapping on an item or [Alt]+Tap on an item
Windows CE Task Manager	[Alt]+[TAB] to switch to another active program or to END Task on running program(s).

1.3 Backlight, Key Light Adjustment

1.3.1 How to Adjust Reducing Time of Backlight

To conserve battery power, this instrument would automatically turn the backlight off or reduce the backlight brightness by itself when it's not in use. In addition, the instrument can control the backlight brightness automatically by an equipped illuminometer.

You can adjust the settings of this function to conserve more battery power or set your liking.

- 1 Press the icon [Start]-[Settings]-[Control Panel]-[Power].

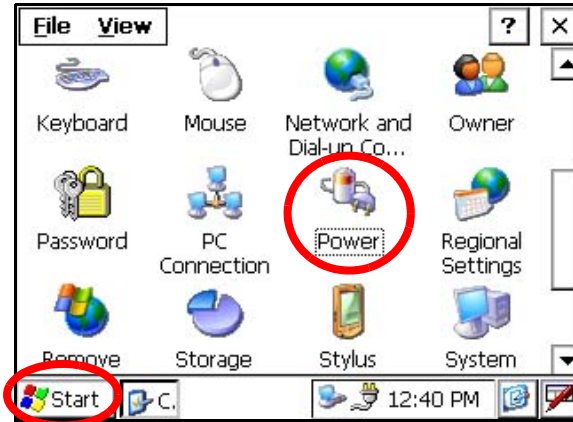

You can see the "Power Properties" screen on Display.

- 2 Press the tab [Backlight].



You can see the "Backlight" screen on Display.

1 NOMENCLATURE AND FUNCTIONS

- 3 Press the time-menu down arrow to select the reducing time.

Factory setting is '3 minutes' as default.

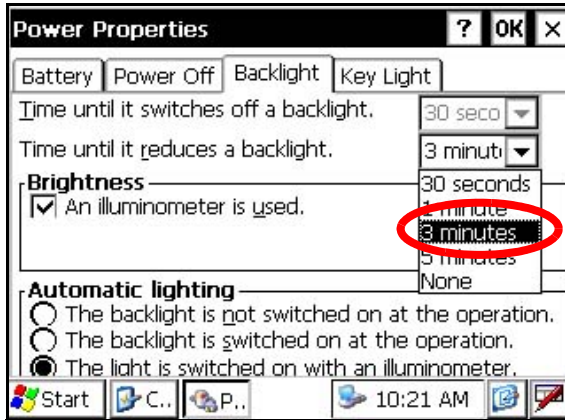

- 4 Press the [OK] key on title bar. After that "Power Properties" screen will close automatically.

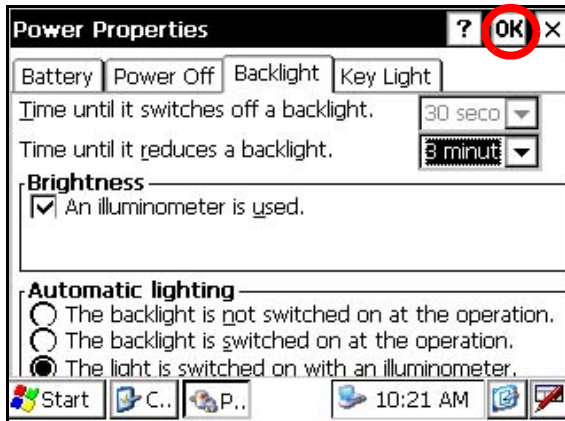

1.3.2 Adjust the Backlight Brightness by Manual

- 1 On the "Backlight" screen, please check it 'OFF' "An illuminometer is used." (Factory setting is 'ON' as default)

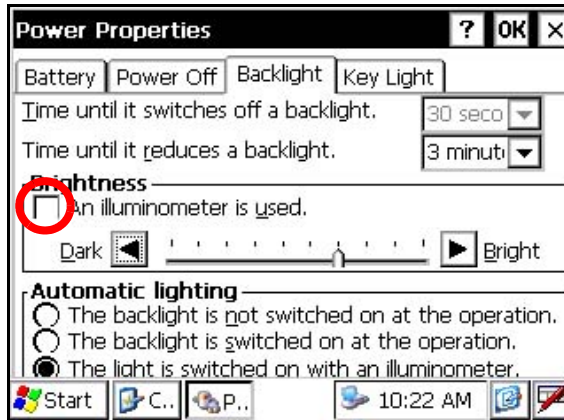

The "Brightness adjusting slide bar" will be appeared on Display.

- 2 Adjust the brightness by pressing [UP-DOWN] button.

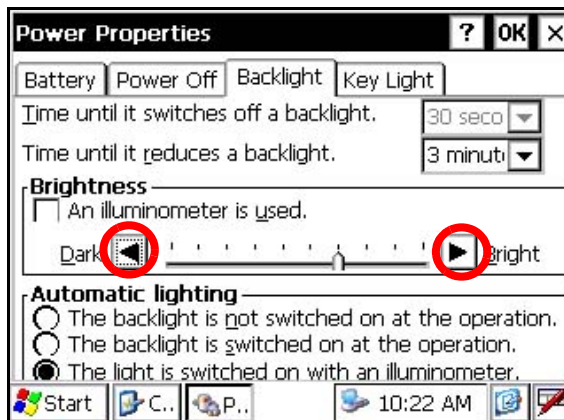

- 3 Press the [OK] key on title bar. After that "Power Properties" screen will close automatically.

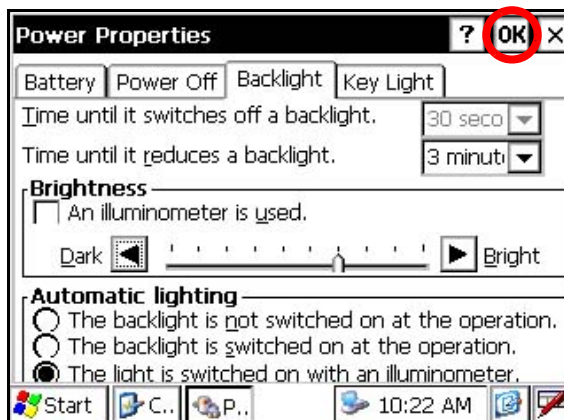

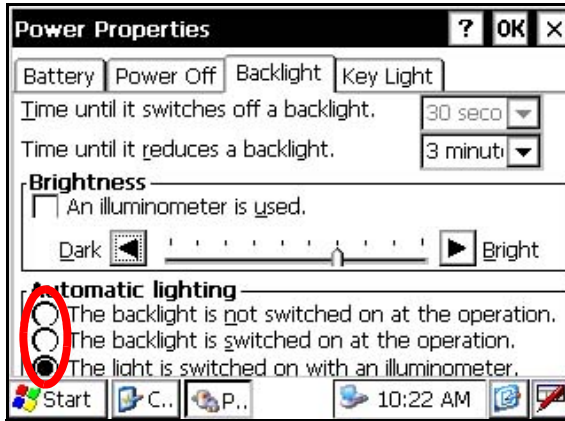

1.3.3 Selecting the Automatic Lighting Option

- 1 On the "Backlight" screen, select a Radio button from "Automatic lighting" column. (Factory setting is "The light is switched on with an illuminometer." as default)

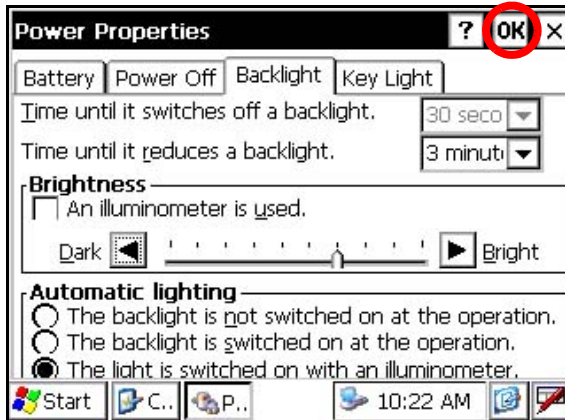

- 2 Press the [OK] key on title bar. After that "Power Properties" screen will close automatically.



 • The "Time until it switches off a backlight." time-menu is not activate if "The light is switched on with an illuminometer." option is selected.

1.3.4 Selecting the Key Light Option

The Key Light option:

[Key light is always off, Key light is always on, Key light synchronizes with backlight]

- 1 Press the tab [Key Light].



You can see the "Key Light" screen on Display.

- 2 Select a Radio button.
(Factory setting is "Key light synchronizes with backlight." as default)

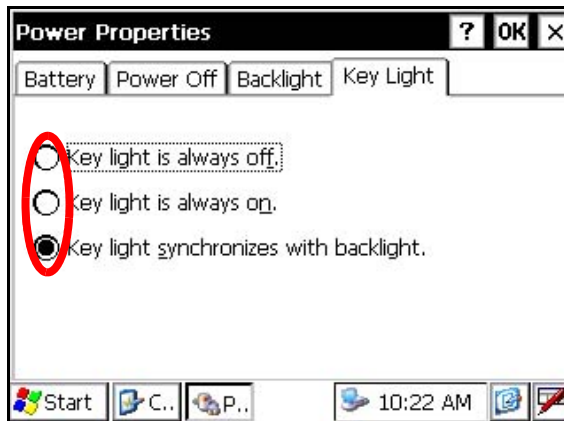

- 3 Press the [OK] key on title bar. After that "Power Properties" screen will close automatically



1.4 RAM Data Backup

If your device had not recharged during several days, the battery will be running down, and you would lose all of data on the device other than that in the "Internal Disk (internal SD card)". In addition, you might perform hardware reset by the hardware problem or software problem. In this case, you would lose all data same as the above.

You can use Backup function of the instrument in order to evade such kind of uneasiness. Your data will be restored to latest condition 1) automatically when rebooting by using the Backup function. The Backup function saves all data files of RAM (except for OS files), registry file and additionally installed programs into named "Backup" folder in the "Internal Disk".
1) The conditions that you executed the backup function last.

 * Restoring former backup data may be incomplete if you upgrade OS version.

1.4.1 Execute the Backup Function

Make sure the mode is Windows CE mode.

- 1 Press the icon [Start]-[Settings]-[Control Panel]-[Backup].

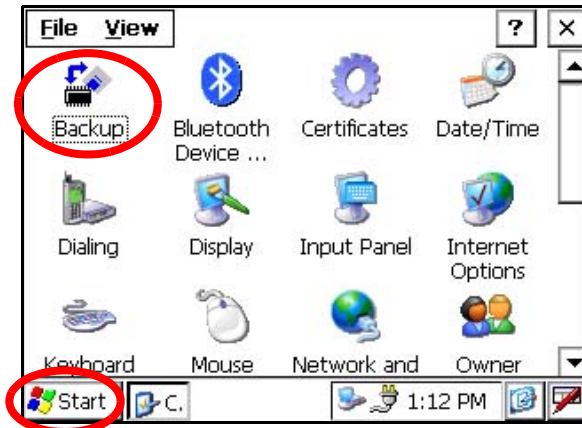

You can see the "RAM Backup" screen on Display.

- 2 Press the [RAM data backup] key.

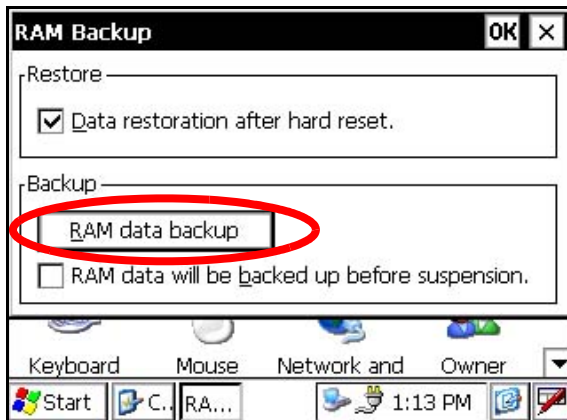

You can see the "Confirmation screen" on display.

3 Press the [YES] key.

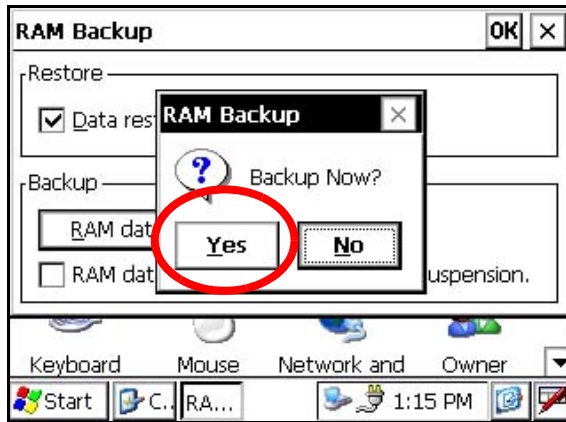

Backup function will start.

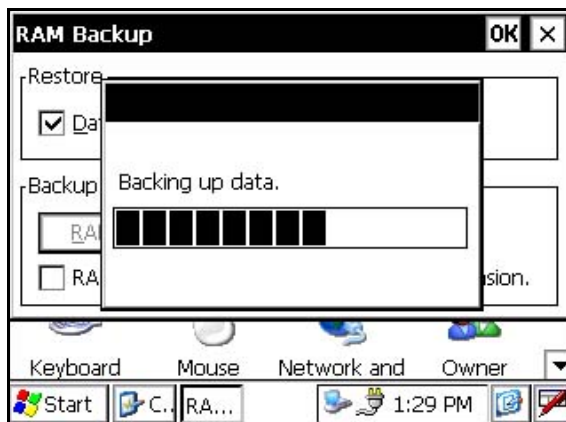

Return to "RAM Backup" screen automatically, when the data back up has been completed.

4 Press the [OK] key on title bar. After that "RAM Backup" screen will close automatically.



- Backing up data may be incomplete if remaining capacity of "Internal Disk" is not enough. Please make sure the remaining capacity of "Internal Disk" before proceeding to the data back up.
- Restoration will be impossible if you delete the "Backup" folder in the "Internal Disk".

1.4.2 Set the Automatic Backup for Every Suspension

- 1 On the "RAM Backup" Screen, please check it 'ON' the "RAM data will be backed up before suspension."
(Factory setting is 'ON' as default)

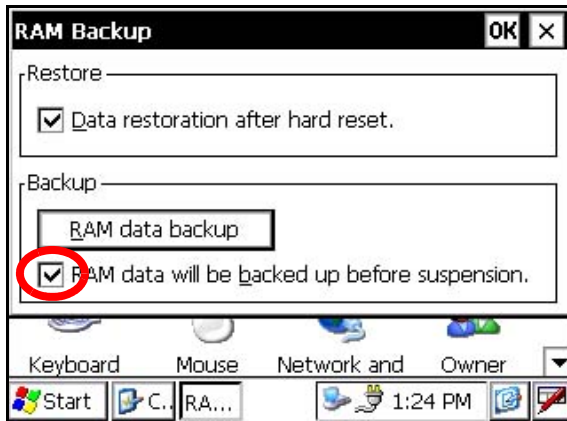

- 2 Press the [OK] key on title bar. After that, "RAM Backup" screen will close automatically.

1.4.3 Set the Restoration Disabled after Hardware Reset

- 1 On the "RAM Backup" Screen, check it 'OFF' the "Data restoration after hard reset."
(Factory setting is 'ON' as default)

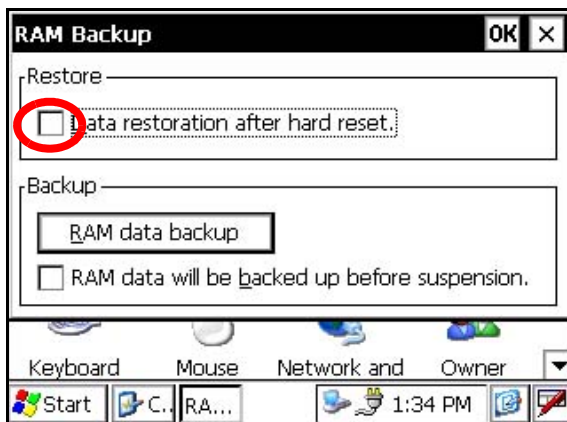

- 2 Press the [OK] key on title bar. After that, "RAM Backup" screen will close automatically.

1.5 Hardware Reset

If your instrument not responding or an application hangs, please try to perform a software reset first. Still, when useless, please perform hardware reset.



You will lose all of data on the device other than that in the "Internal Disk" after hardware reset and will need to reinstall the applications and the data you install on your instrument.

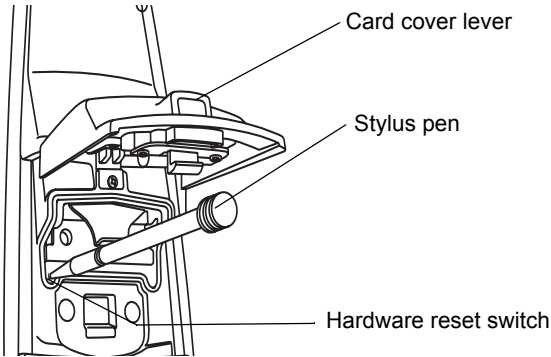

1 Pull the card cover lever to open the card cover.

2 Insert the stylus into the unit of hardware reset switch.

3 Press the switch for two seconds.

The instrument will reboot.

1.6 Cover Sensor

Completely close the battery cover before using the instrument.

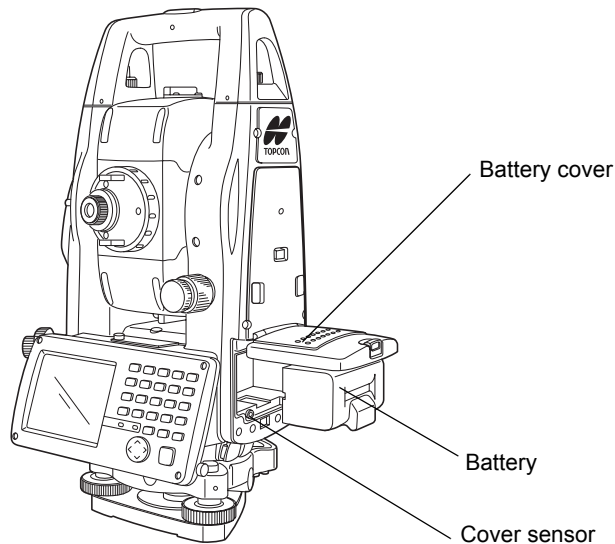

- If the battery cover is not completely closed, the instrument will not operate normally, regardless of whether the battery or the external power source is used.
- If the battery cover is opened while the instrument is in operation, operation will automatically be suspended.

1.7 Touch Panel Calibration

If your instrument is not responding properly to your taps, you may need to calibrate the touch panel.

- How to calibrate the touch panel



- 1 Press the icon [Start]-[Settings]-[Control Panel]-[Stylus].

You can see the "Stylus Properties" screen on Display.

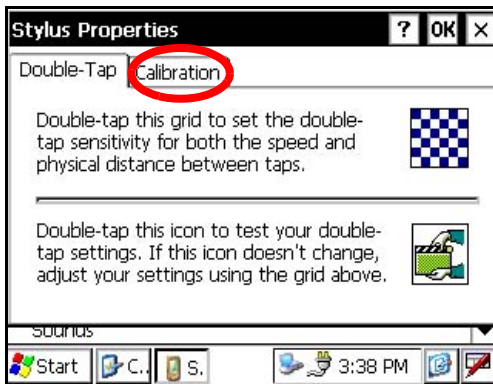

- 2 Press the tab "Calibration".

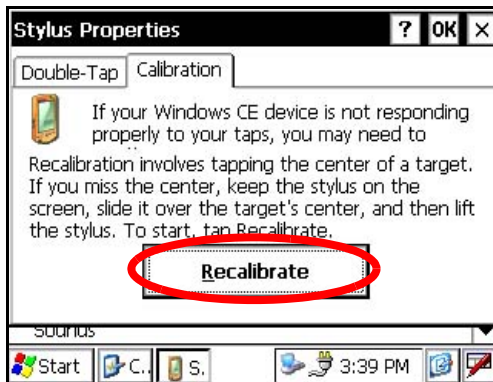

- 3 Press the [Recalibrate] key.

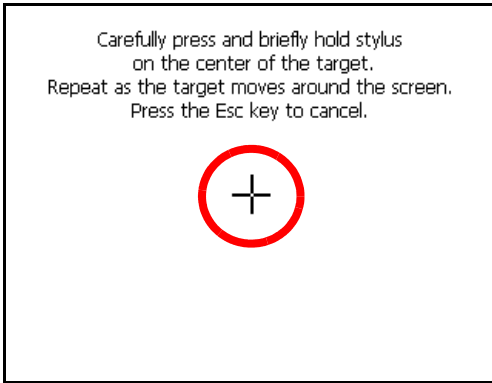

4 Using the stylus pen, press the center of the targets on the screen.

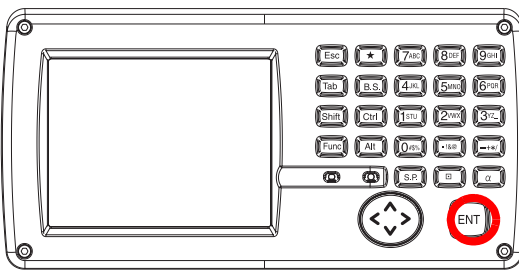

5 After pressing all targets (5 points), press the [ENT] key, or tap the display.

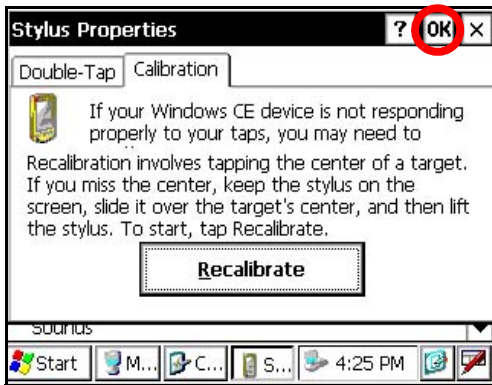

6 Press the [OK] key.
The display returns to previous menu.

1.8 Operating Panel Key



To operate the keys on the screen, touch them lightly with either the accessory stylus pen or your finger.

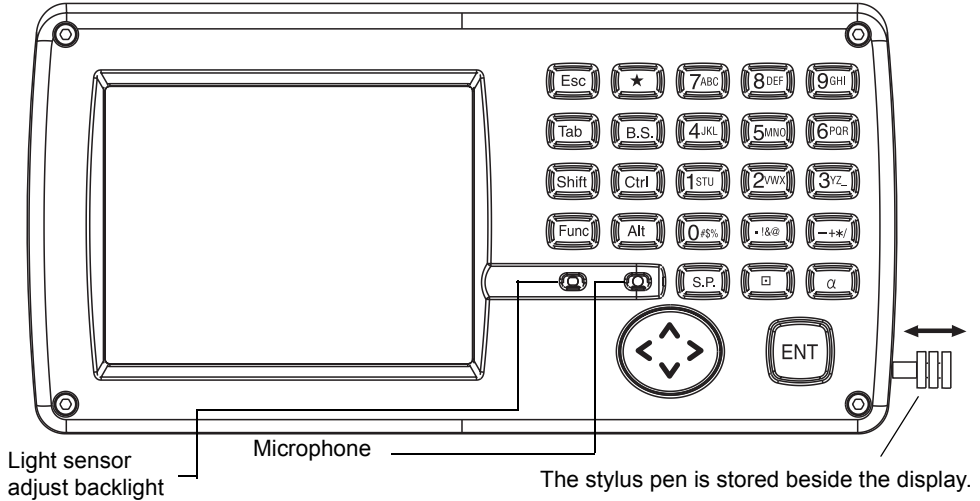

Use either the stylus pen or your finger.
Do not use a ballpoint pen or a pencil.

1.8.1 Operating Key



Keys	Name of Key	Function
0~9	Numeric key	Entering numerals.
A ~/	Alpha key	Entering Alphabets.
Esc	Escape key	Returning to the previous mode or display.
★	Star key	Star key mode is used for each presetting or displaying.
ENT	Enter key	Press at the end of inputting values.
Tab	Tab key	Moves the cursor to the right or downwards.
B.S.	Back space key	When inputting numbers or characters, return the cursor to the left.
Shift	Shift key	Used with other keys. Refer to "1.2.5 Shortcut Keys".
Ctrl	Control key	Used with other keys. Refer to "1.2.5 Shortcut Keys".
Alt	Alt key	Used with other keys. Refer to "1.2.5 Shortcut Keys".
Func	Function key	Used with other keys. Refer to "1.2.5 Shortcut Keys".
d	Alphabet key	Switches the keys to alphabet input mode.
	Cursor	Moves the selected item or the cursor laterally and vertically.
S.P.	Space key	Inputs a space.
	Input panel key	Displays the software input panel.

1.9 Power OFF

When turning off the power, be sure to turn off the GTS-750/GPT-7500's power switch.



- Do not turn off the power by removing the battery. Before removing the battery, press the power switch and confirm that the power is off. Then remove the battery.
- While using the external power source, do not turn off the GTS-750/GPT-7500 with the switch on the external power source.

If the above-mentioned operating procedure is not followed, then, the next time that power is turned on, it will be necessary to reboot the GTS-750/GPT-7500.

1.10 Function Key (Soft Key)

The functions are according to the displayed message.

Angle measuring mode (Page 1)

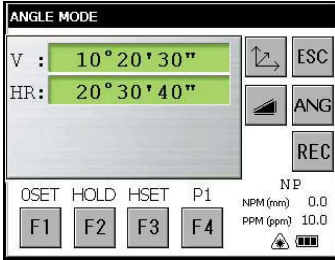

Angle measuring mode (Page 2)

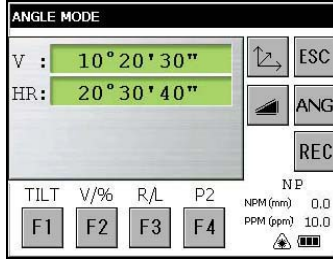

Angle measuring mode (Page 3)

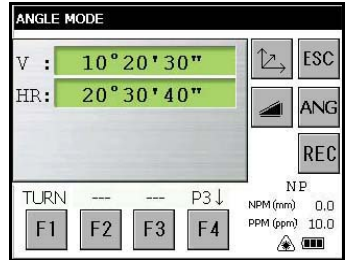

Distance measuring mode (Page 1)

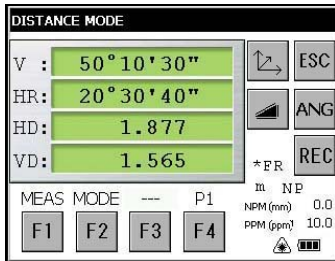

Distance measuring mode (Page 2)

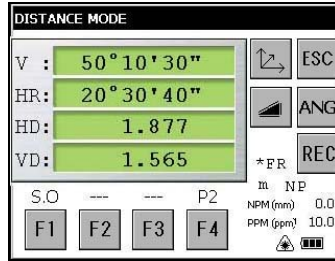

Coordinate measuring mode (Page 1)

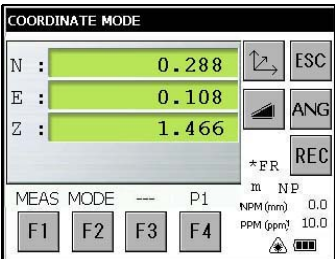

Coordinate measuring mode (Page 2)

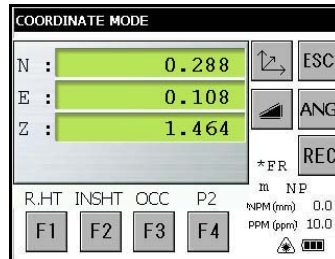

Angle measuring mode

Page	Soft key	Display	Function
1	F1	0SET	Angle of horizontal is set to 0° 00'00".
	F2	HOLD	Holds the horizontal angle.
	F3	HSET	Sets the horizontal angle by input value.
	F4	P1	The function of soft keys on next page (P2).
2	F1	TILT	Sets the tilt function, ON/OFF. If ON, the display shows tilt correction value.
	F2	V/%	Switches the vertical angle and percent grade.
	F3	R/L	Switches R/L rotation of horizontal angle.
	F4	P2	The function of soft keys on next page (P1).

Distance measuring mode

1	F1	MEAS	Distance measuring starts.
	F2	MODE	Sets to the mode for Fine, Coarse or Coarse 10mm.
	F3	---	---
	F4	P1	The function of soft keys on next page (P2).
2	F1	S.O	To be stake out measurement mode.
	F2	---	---
	F3	---	---
	F4	P2	The function of soft keys on next page (P1).

Coordinate measuring mode

1	F1	MEAS	Coordinate measuring starts.
	F2	MODE	Sets to the mode for Fine, Coarse or Coarse 10mm.
	F3	---	---
	F4	P1	The function of soft keys on next page (P2).
2	F1	R.HT	Sets a Reflector Height by input value.
	F2	INSHT	Sets an Instrument Height by input value.
	F3	OCC	Sets an occupied point by input values.
	F4	P2	The function of soft keys on next page (P1).

1.11 Star Key Mode

Press the star (★) key to view the instrument options.

The following instrument options can be selected from the star key:

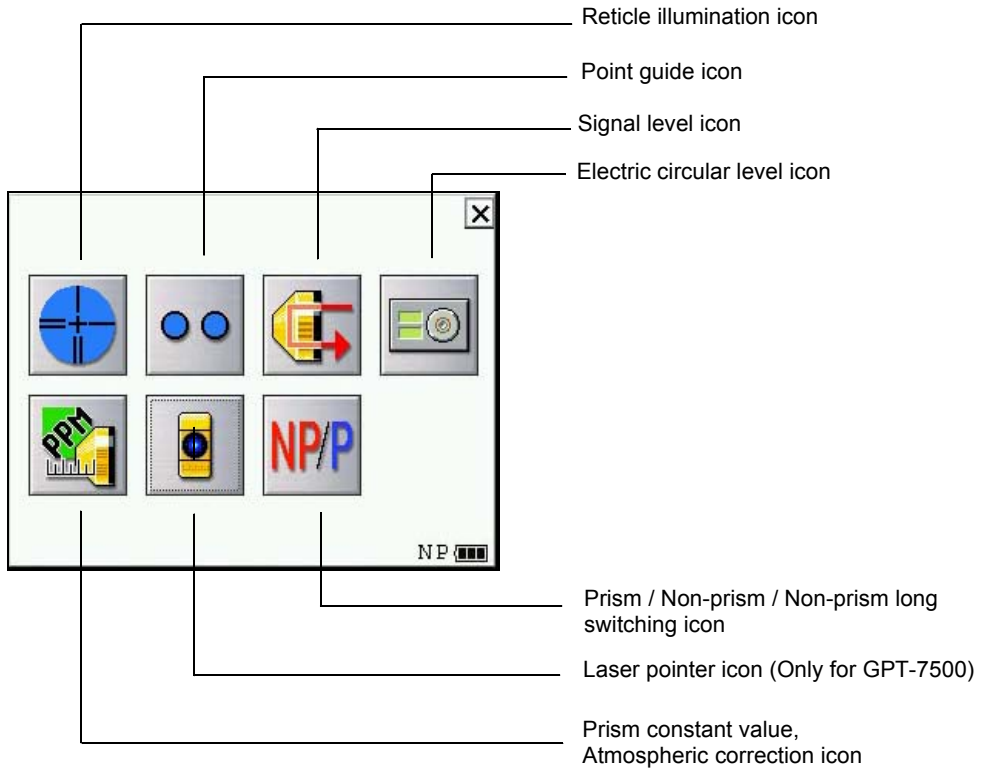

- **Electric circular level graphic display**

Electric circular level can be displayed by graphic. This function is good for level the instrument when the circular level is difficult to see directly. In the displays of reverse side, the graphic bubble moves in reverse.



Rotate the leveling screws while observing the display.

- **Point guide ON/OFF**

This feature is most useful when doing stake out work. The Point Guide's red LEDs on the GTS-750/GPT-7500 Series telescope assist the rod person in getting on-line. The Point Guide feature is fast and simple to use.

The Point Guide should be used within a distance of 100 meters (328 ft.). The quality of its results will depend on the weather conditions and the user's eyesight.

The goal of the rod person is to look at both LEDs on the instrument and move the prism on-line until both LEDs become equally bright. If the solid LED is brighter, move to the right. If the blinking LED is brighter, move to the left.

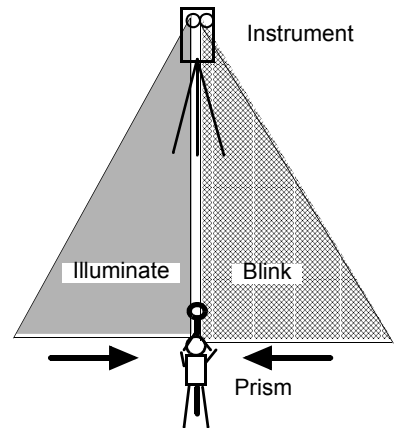

1 NOMENCLATURE AND FUNCTIONS

- **Signal level mode**

The light acceptance quantity level (Signal level) is displayed in this mode. When reflected light from the prism is received, a buzzer sounds. This function is good for easy collimation when the target is difficult to find.

The received return signal level is displayed with bar graph as follows.

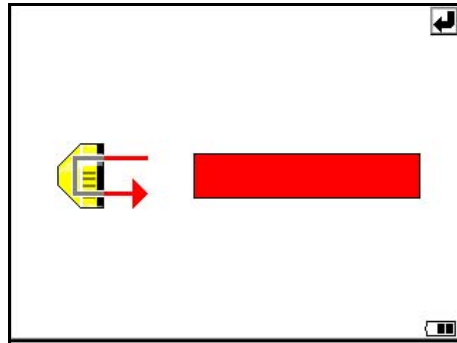

- **Reticle illumination**

Select the brightness by sliding [UP-DOWN] slider. The brightness setting is stored in memory after power is turned off. To turn on or off the reticle illumination, press the [reticle illumination] icon.

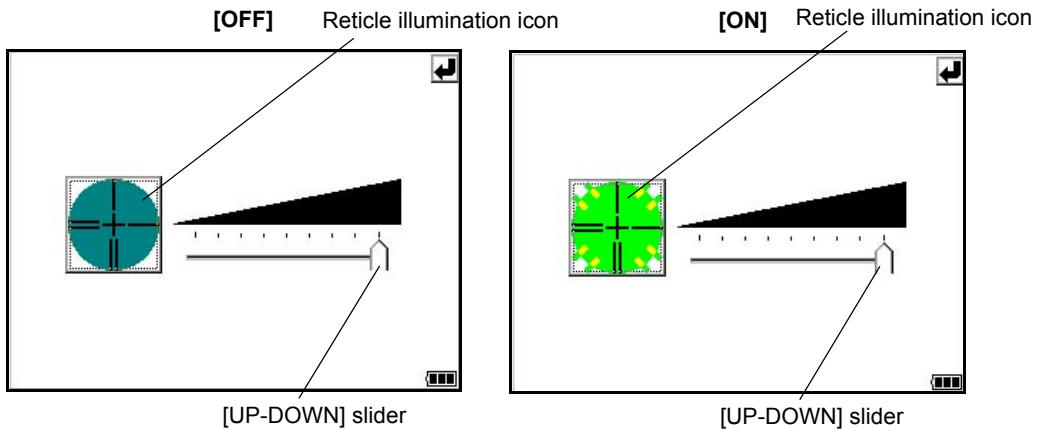

- **Laser Pointer ON/ON(blink)/OFF (GPT-7500)**

The laser pointer assists with collimation by radiating visible laser light from the objective lens to the target. The laser pointer can be used for the Prism, Non-prism and Non-prism long mode.

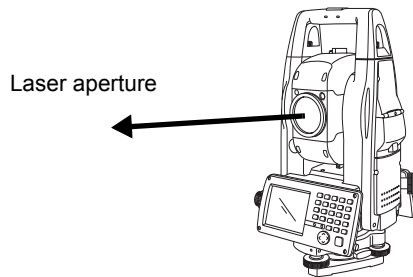

- The laser pointer indicates the approximate collimation position of the telescope. It does not indicate the exact collimation position.
- When the EDM is working, the laser pointer will blink.
- You cannot see the laser pointer when looking through the telescope. Therefore, please look directly, with the naked eye, at the point indicated by the laser pointer.
- The distance to which the laser pointer can be used will vary with climatic conditions and with the eyesight of the user.
- When the laser pointer is used, the operating time of internal power source will become short.
- When the GPT-7500/GPT-9000M is used in the open air, in an urban area, etc., the laser pointer can be stopped and distance measurement then conducted, making it possible to prevent the laser light from hitting a third party.
- Use the operation keys on the telescope eyepiece side for key operation. If you use the operation keys on the objective lens side, an error will be displayed and the laser pointer will not turn on. This prevents the laser beam from hitting the eyes of the operator.

- **Non-prism mode / prism mode**

To switch the non-prism / prism mode, press the Non-prism / prism switching icon.
For more information, see Chapter 3.2 "Distance Measurement".

1.11.1 Switching Measurement Distance Modes

Pressing the [Prism / Non-prism / Non-prism long switching] icon displays the following screen. Each mode can be switched by using the buttons as shown below.

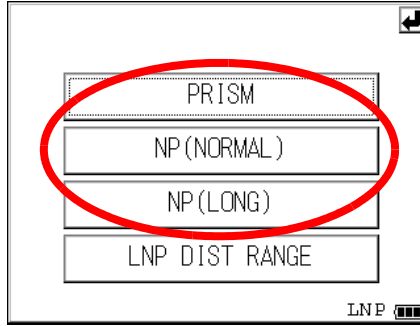

- **Setting Measurement distance range of ‘Non-prism long mode’**

It is possible to measure long distance in the Non-prism Long mode. However, not all beams can be thrown onto the target object since the diameters become bigger at long distance. In such a case, the beam may also reach behind (or front) the object and the measurement may cause inaccuracies. (See “Precautions for Use of Non-prism long mode” on page 57.)

If there is a certain distance between the object and its rear (or front), the correct measurement can be obtainable by setting the measuring range.

Input range : 5m (17ft) - 1,800m (5,900ft)

Measuring range : from the distance you input to 200m backward

[e.g.]

When the distance to the target object is about 500m and when the distance to the wall behind the object is about 700m, input 400m and measure between 400m and 600m. This will eliminate the wall 700m ahead.

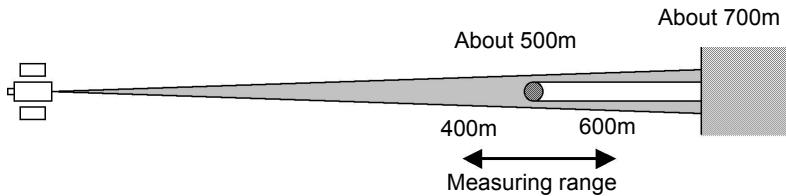

To set measurement distance range, see Section 3.2.3“Setting Measurement distance range of Non-prism long mode” .

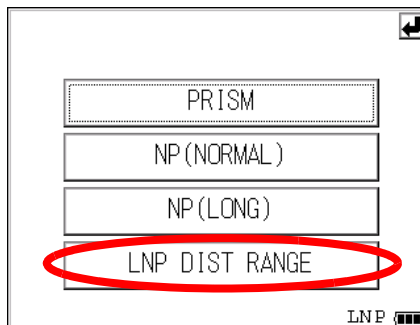

1.11.2 Setting by Using Star Key

[Example] : Switch on the laser pointer

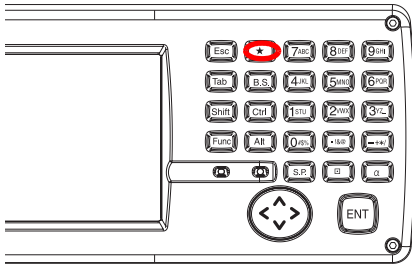

- 1 Turn the power switch on.
- 2 Press the [★] key.

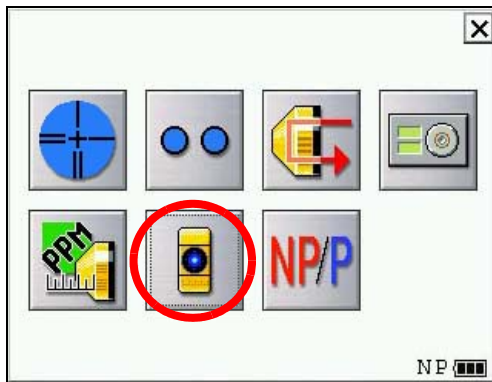

- 3 Press the [Laser pointer] icon.

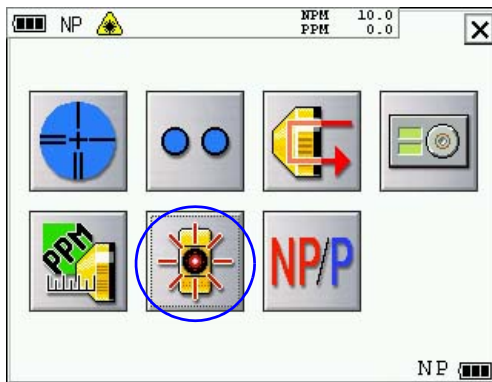

The laser pointer will be turned on.

1.12 Auto Power Off

To save battery power, the GTS-750/GPT-7500 would automatically turn the power off (suspend) by itself when it's not in use. You can adjust the settings of this function.

- How to adjust the settings of auto power off function

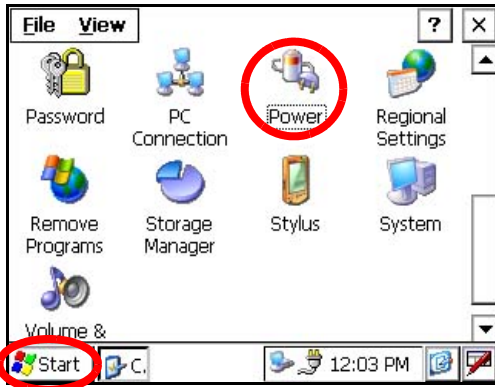

- 1 Press the icon [Start]-[Settings]-[Control Panel]-[Power].

You can see the "Power Properties" screen on Display.



- 2 Press the tab "Power Off".

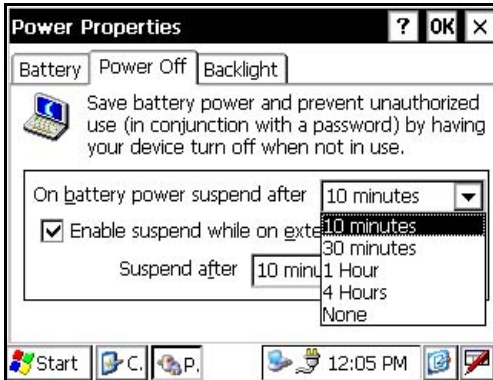

- 3 Press the time-menu down arrow to select the auto power off time.

(Factory setting is '10 minutes' as default)

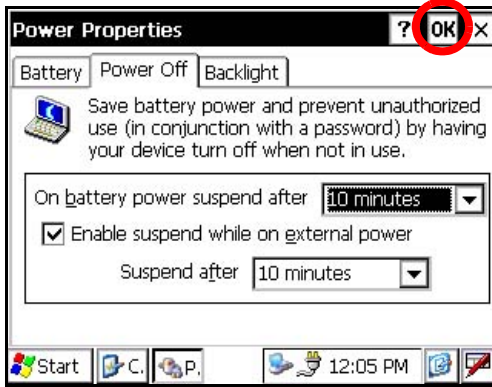

- 4 Press the [OK] key on title bar.
After that "Power Properties" screen will close automatically.



While on external power, the auto power off function can be enabled too.

To set this function, please check it 'ON' the "Enable suspend while on external power" on the "Power Off " screen, and select the auto power off time.
(Factory setting is 'OFF' as default)

1.13 Using the USB Port

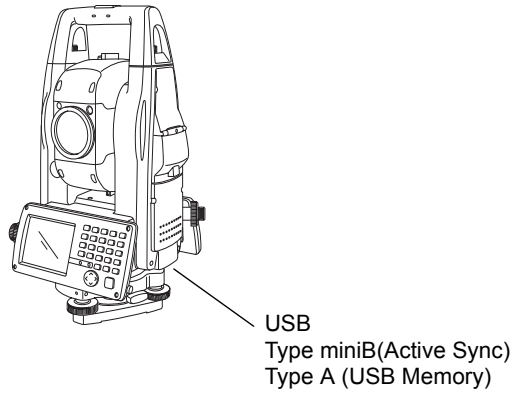

- **Using ActiveSync**

For Type mini B, refer to Chapter 2.9 “Active Sync”.

- **Using a USB memory**

- 1 Open the USB Port cover.
- 2 Insert a USB memory into the Type A side.
- 3 Confirm that the USB memory has been recognized.



When using the USB port (Mini B, Type A), do not rotate the instrument.

It will cause damage to the instrument, USB memory or F-25 cable.

2 PREPARATION FOR MEASUREMENT

2.1 Power Connection

Obtain power from BT-65Q battery or an external battery.

- When using the BT-65Q, leave the power of the instrument switched ON.
- When using an external battery, leave the BT-65Q battery mounted onto the instrument.

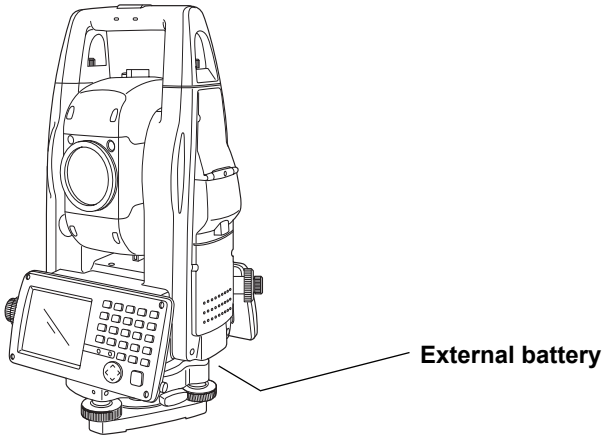

- Selecting an external battery

When using an external battery, select the battery type, either "Li-ion" or "12V BATTERY."

Regarding operating procedures, refer to Chapter 5 "PARAMETERS SETTING MODE".

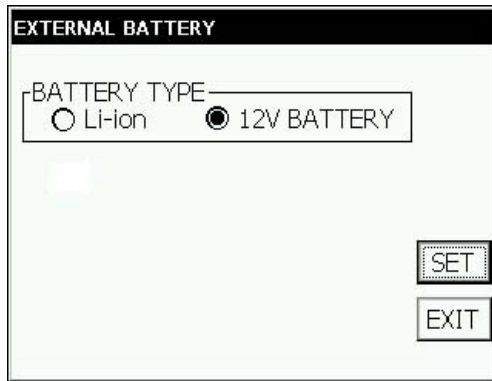

2.2 Setting Instrument Up For Measurement

Mount the instrument to the tripod. Level and center the instrument precisely to insure the best performance. Use tripods with a tripod screw of 5/8 in. diameter and 11 threads per inch, such as the Type E TOPCON wide- frame wooden tripod.

Reference: Leveling and Centering the Instrument

1. Setting up the Tripod

First, extend the extension legs to suitable lengths and tighten the screws on their midsections.

2. Attaching the Instrument on the Tripod Head

Place the instrument carefully on the tripod head and slide the instrument by loosening the tripod screw. If the plumb bob is positioned right over the center of the point, slightly tighten the tripod screw.

3. Roughly Leveling the Instrument by Using the Circular Level

- 1 Turn the leveling screws A and B to move the bubble in the circular level. The bubble is now located on a line perpendicular to a line running through the centers of the two leveling screws being adjusted.

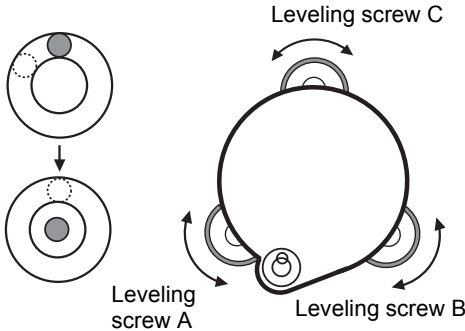

- 2 Turn the leveling screw C to bring the bubble to the center of the circular level.

4. Centering by Using the Plate Level

- 1 Rotate the instrument horizontally by using the Horizontal motion/clamp screw and place the plate level parallel with the line connecting leveling screws A and B, and then bring the bubble to the center of the plate level by turning leveling screws A and B.

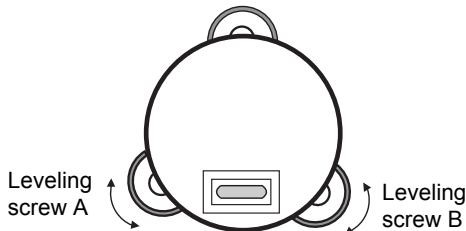

- 2 Rotate the instrument 90° (100g) around its vertical axis and turn the remaining leveling screw or C to center the bubble once more.

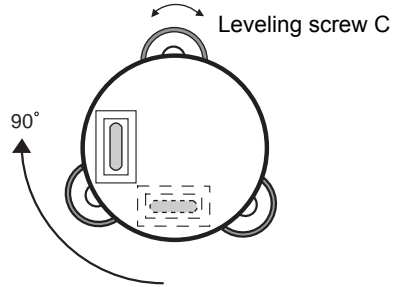

- 3 Repeat the procedures 1 and 2 for each 90° (100g) rotation of the instrument and check whether the bubble is correctly centered for all four points.

5. Centering by Using the Optical Plummet Telescope

Adjust the eyepiece of the optical plummet telescope to your eyesight. Slide the instrument by loosening the tripod screw, place the point on the center mark, and then tighten the tripod screw. Sliding the instrument carefully not to rotate that allows you to get the least dislocation of the bubble.

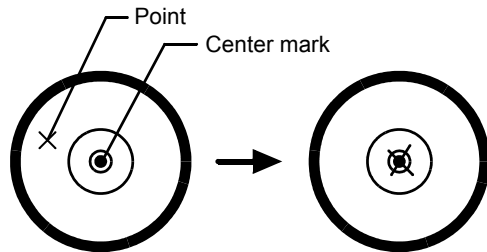

6. Completely Leveling the Instrument

Leveling the instrument precisely in a similar way to 4. Rotate the instrument and check to see that the bubble is in the center of the plate level regardless of telescope direction, then tighten the tripod screw hard.

2.3 Power Switch Key ON



Main menu

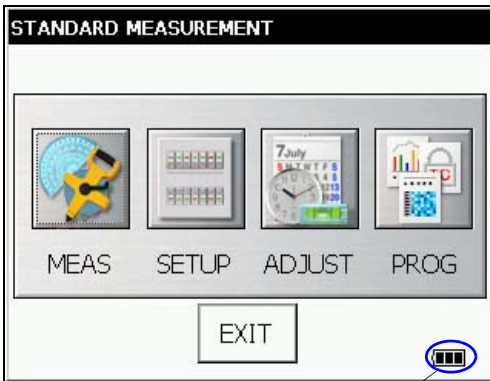

1 Confirm the instrument is leveled.

Turn the power switch ON.

Progress bar will be displayed during reloading the Operating System, after you turn the instrument on at the first time or perform hardware reset.

You will see the Desktop display of Windows CE with "Standard Meas." icon.

2 Press the "Standard Meas." icon.

The main menu will be displayed.

- Confirm the battery power remaining on the display. Replace with charged battery or charge when battery level is low. see section 2.4 "Battery Power Remaining Display" .

2.4 Battery Power Remaining Display

Battery power remaining display indicates the power condition.

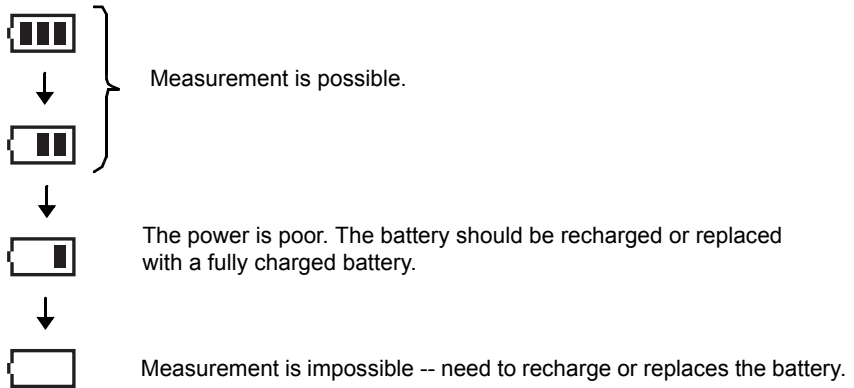
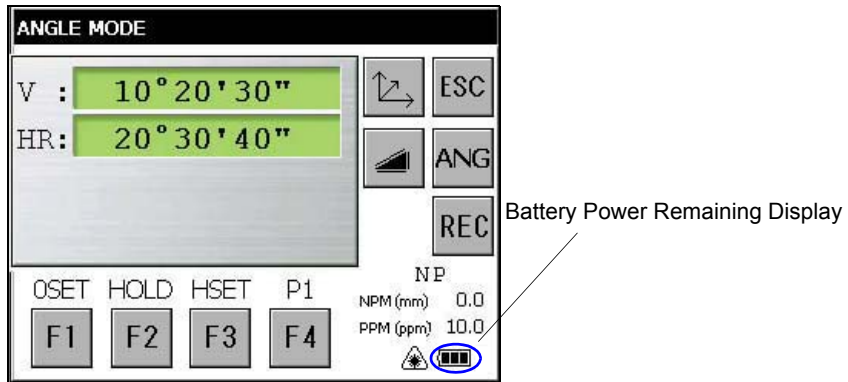

Note:

- 1) The battery operating time will vary depending on the environmental conditions such as ambient temperature, charging time, the number of times of charging and discharging etc. It is recommended for safety to charge the battery beforehand or to prepare spare full charged batteries.
- 2) For general usage of the battery, see Chapter 10 "POWER SOURCE AND CHARGING" .
- 3) The battery power remaining display shows the power level regarding to the measurement mode now operating.
 The safety condition indicated by the battery power remaining display in the angle measurement mode does not necessarily assure the battery's ability to be used in the distance measurement mode.
 It may happen that the mode change from the angle mode to the distance mode will stop the operation because of insufficient battery power for the distance mode which consumes more power than angle mode.
- 4) When the measurement mode is changed, it rarely may happen that the Battery Power Remaining Display will decrease or increase two steps momentarily because of the accuracy of the battery checking system is rough. It is not trouble with the instrument.

2.5 Vertical and Horizontal Angle Tilt Correction

When the tilt sensors are activated, automatic correction of vertical and horizontal angle for mislevelment is displayed.

To ensure a precise angle measurement, tilt sensors must be turned on. The display can also be used to fine level the instrument. If the (TILT OVER) display appears the instrument is out of automatic compensation range and must be leveled manually.

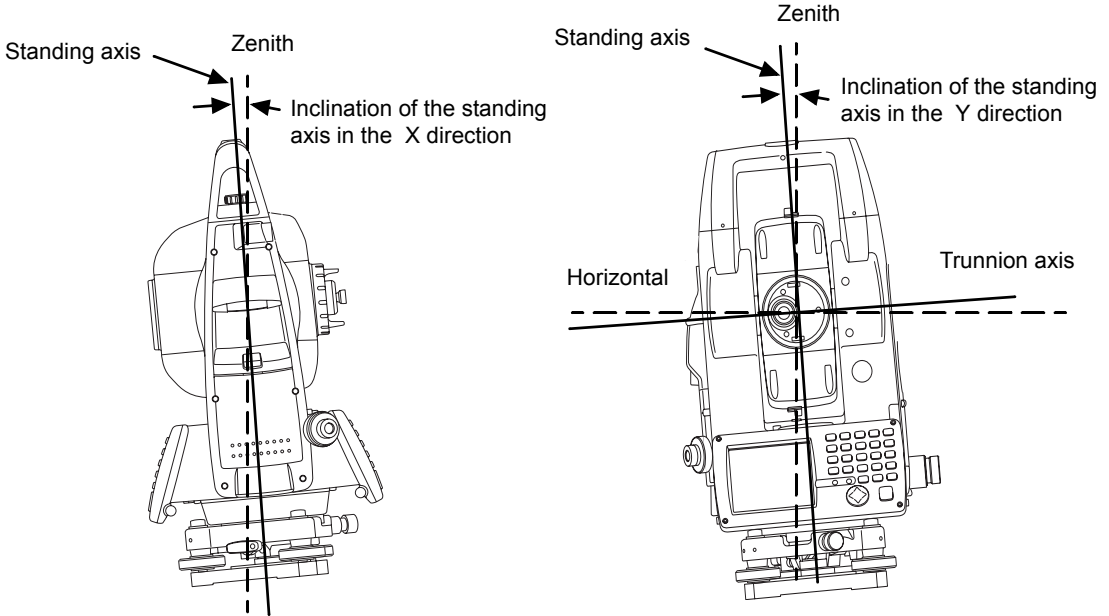

- GTS-750/GPT-7500 compensates both the vertical angle and the horizontal angle readings due to inclination of the standing axis in the X and Y directions.
- For more information about dual axis compensation, see Chapter 18 “APPENDIX” .

When the instrument is out of compensation. (TILT OVER)

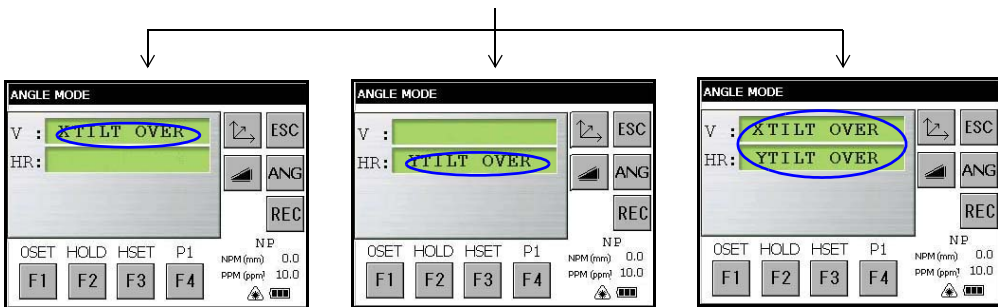

Standing Axis in the X direction out of range

Standing Axis in the Y direction out of range

Standing Axis in the X and Y directions out of range

- The display of Vertical or Horizontal angle is unstable when instrument is on an unstable stage or a windy day. You can turn off the auto tilt correction function of V/H angle in this case. To set TILT correction mode ON/OFF, refer to section 2.5.1 “Setting Tilt Correction by Soft Key” or Chapter 5 “PARAMETERS SETTING MODE”

2.5.1 Setting Tilt Correction by Soft Key

[Example] Setting Tilt OFF

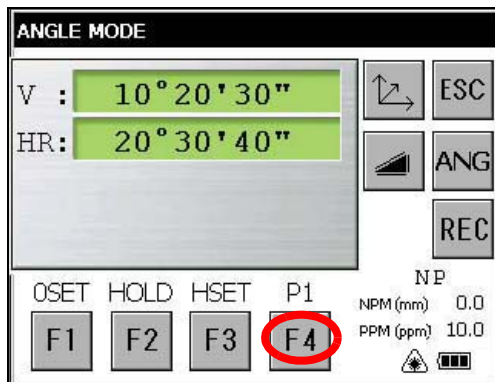

1 Press the [F4] key to get the function page 2.

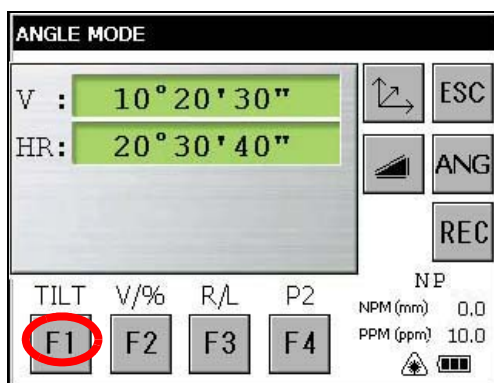

2 Press the [F1] key.
Current setting is displayed.

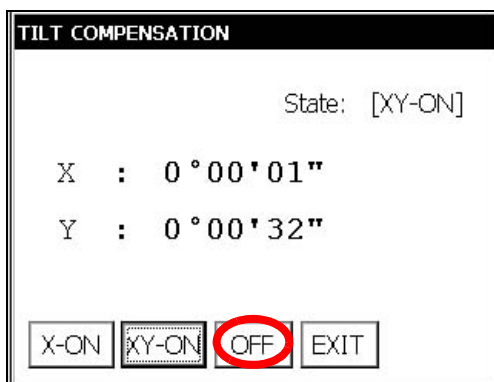

3 Press [OFF] key.

4 Press [EXIT] key.
The display returns previous mode.

- The setting performed here will be interlocked with setting in Chapter 5 "PARAMETERS SETTING MODE"

2.6 Compensation of Systematic Error of Instrument

- 1) Error of vertical axis (X,Y tilt sensor offset)
- 2) Collimation error
- 3) Error of vertical angle 0 datum
- 4) Error of horizontal axis

The above mentioned errors can be compensated by software, which calculated internally according to each compensation value.

Also these errors can be compensated by software collimating one side of the telescope that is carried out to delete the error by turning in normal and reverse both sides of telescope so far.

- To adjust or reset the above compensation value, see Chapter 6 "CHECK AND ADJUSTMENT" .
- Enable you to stop this function, see Chapter 5 "PARAMETERS SETTING MODE" or Chapter 6 "CHECK AND ADJUSTMENT"

2.7 How to Enter Numerals and Alphabet Letters

This instrument supports two ways to enter numerals and alphabet letters.

One is by physical(hardware) keyboard that is similar to cellular phone method. Three alphabet characters are assigned to one numeral key.

The other is by using the software input panel.

Press the [□] key or press keyboard icon on the task bar will invoke the software input panel.

- [Example] : Enter "job_104" as the New Folder name by physical(hardware) keyboard. Make sure the mode is Windows CE desktop screen.

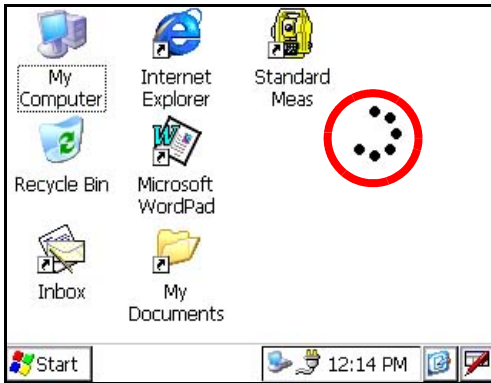

- 1 Press and hold the background of Desktop.
You can see the "Pull down menu" on Display.



- 2 Select "New Folder".



You can see the "New Folder" waiting a new name inputting on Display.



Alphabet letter mode indicator

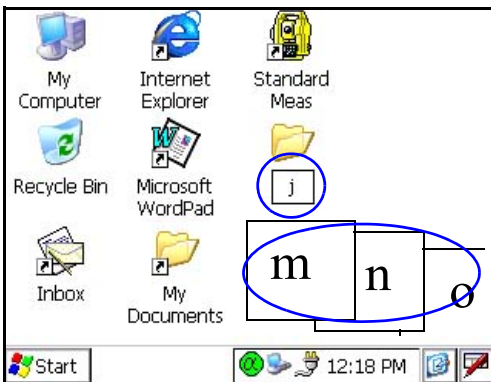
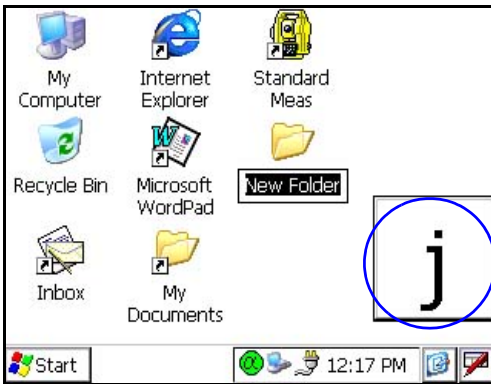

- 3 Press the [**α**] key to be entering alphabet letter mode.

Alphabet letter mode indicator will be appeared on the task bar.

- 4 Enter Alphabets.

Input 'j',
Press [4](JKL)key. then the sub window featuring 'j' character will appear on the display which indicate a entering character.

Then 'j' will be displayed.

- 5 Input 'o',
Press [5](MNO),[5],[5].
The character in the sub window will be altered 'm', 'n', 'o'.

Then 'o' will be appended after 'j'.

- 6 Input 'b',
Press [7](ABC), [7].The character in the sub window will be altered 'a', 'b'.
Then 'b' will be appended after 'jo'.

- 7 Input '_',
Press [3](YZ_), [3], [3].
The character in the sub window will be altered 'y', 'z', '_'.
Then '_' will be appended after 'job'.

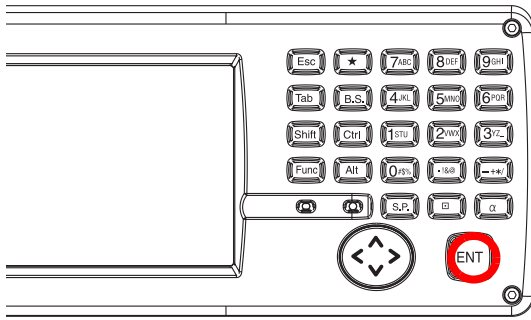

- 8** Press the [] key to be returning numeric mode.
Alphabet letter mode indicator will be disappeared on the task bar.
- 9** Input '104',
Press [1], [0], [4].
Then '104' will be appended after 'job_'.
- 10** Press the [ENT] key.

In alphabet letter mode, [Shift] + [0-9,.-] keys perform uppercase character.

- Invoke the software input panel.

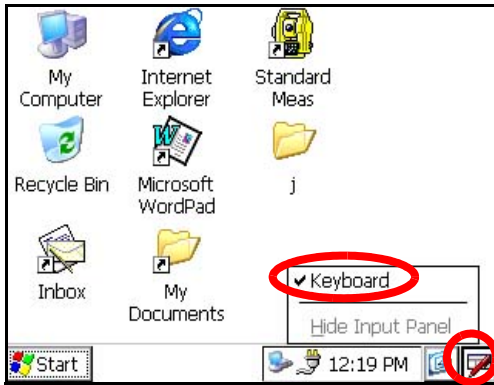

- 1 Press the [⌄] key or press keyboard icon on the task bar and select "Keyboard"

You can see the software input panel on display.

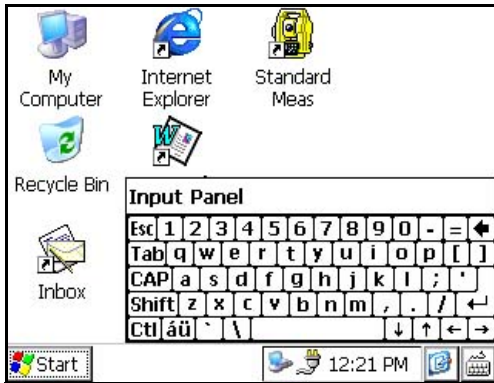

You can input data as if you were typing on your PC keyboard.

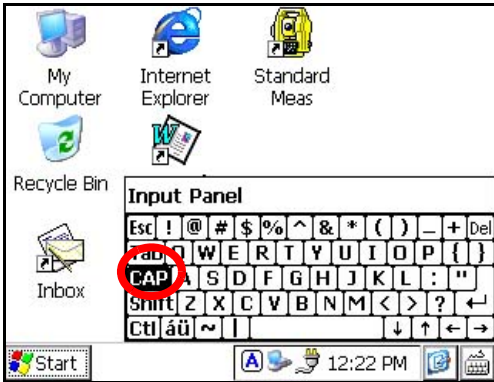

To change the keyboard:

Press the [CAP] key or the [au] key.

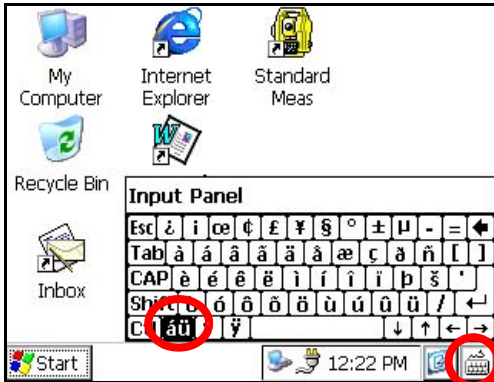

- 2 To hide the software input panel, press the [⌄] key or press keyboard icon on the task bar and select "Hide Input Panel".

2.8 Data Memory Card

• How to insert a data memory card(CF card)

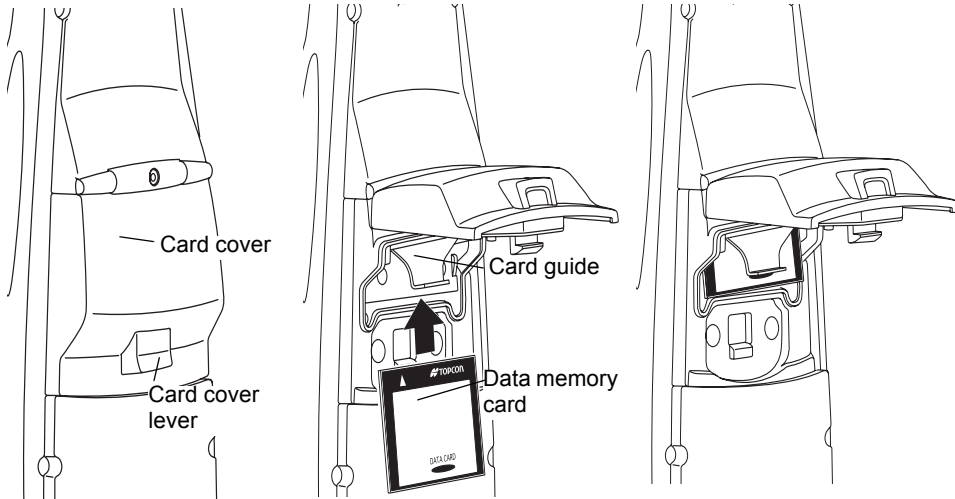

- 1 Push up the card cover lever to open the card cover.
- 2 Insert a data memory card.

Please make sure you have the front and back of the CF cards facing correctly when inserting into the card slot.
If you forcibly insert the card incorrectly, the pin at the card slot may be damaged and cause a breakdown.

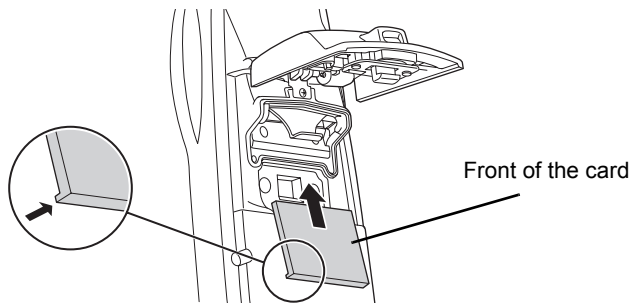

Please insert straight up into the card slot.
If you forcibly insert the card at an angle, the pin at the card slot may be damaged and cause a breakdown.

- 3 Close the card cover.

• How to extract a data memory card

- 1 Push up the card cover lever to open the card cover.
- 2 Pull down the card guide.
Note: Hold the card with your hand to protect the card against falling.
- 3 Extract the card.
- 4 Close the card cover.

2.9 Active Sync

Microsoft ActiveSync is the data synchronization software:
It synchronizes data between Windows CE devices (such as the GTS-750/GPT-7500) and PCs.

Using ActiveSync, the GTS-750/GPT-7500 can exchange data to a PC via USB cable.
To establish a connection between the instrument and your PC, you first need to install ActiveSync in your PC.

For downloading ActiveSync, access the following website.
<http://www.microsoft.com/windowsmobile/>

2.9.1 Getting Connected

- 1 Install ActiveSync in your PC (if it is not already installed).
- 2 Connect the instrument to your PC with an interface cable F-25 as shown below.

GTS-750/GPT-7500

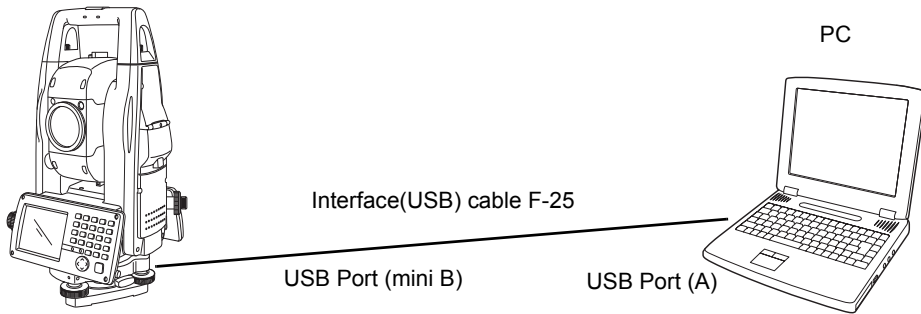

- 3 The instrument will give the prompt, "Conneting to Host".
- 4 The PC will prompt you to set up a partnership or set up as a guest.
- 5 Select the [NO] key to setting up as a guest.
- 6 Press the [Next] key.
Once a connection has been established, the ActiveSync window will appear on your PC.
- 7 Click the [Explorer] icon. You will then see the GTS-750/GPT-7500 file structure.

3 STANDARD MEASUREMENT MODE

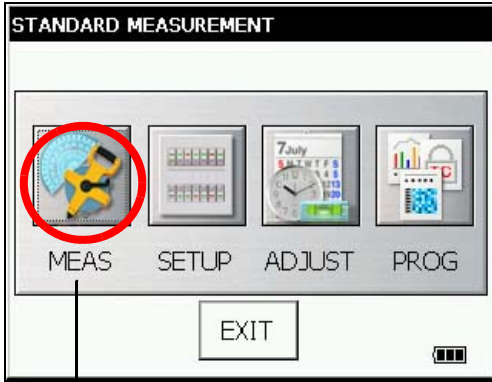

STANDARD MEASUREMENT MODE
 Angle measurement, Distance measurement, Coordinate measurement .
 Press the [MEAS] icon.

3.1 Angle Measurement

3.1.1 Measuring Horizontal Angle Right and Vertical Angle

Make sure the mode is in angle measurement.

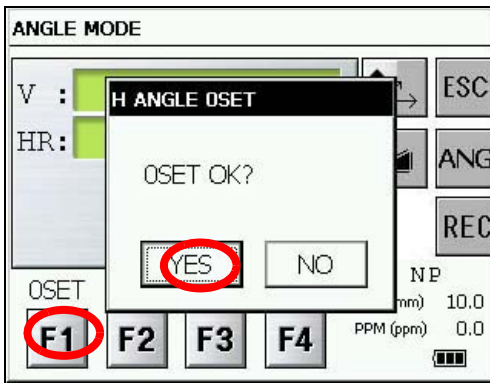

- 1 Collimate the 1st target (A).
- 2 Set horizontal angle of target (A) at 0° 00' 00". Press the [F1] key and the [YES] key.

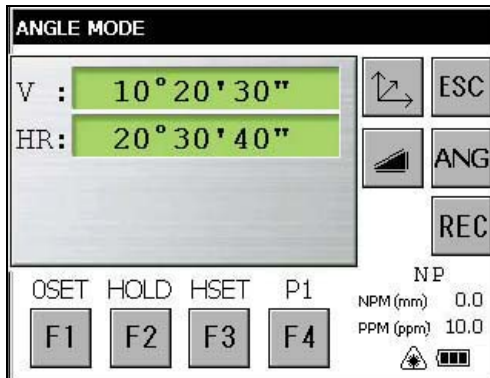

- 3 Collimate the 2nd target (B). The required H/V angle to target B will be displayed.

3.1.2 Switching Horizontal Angle Right/Left

Make sure the mode is angle measurement.

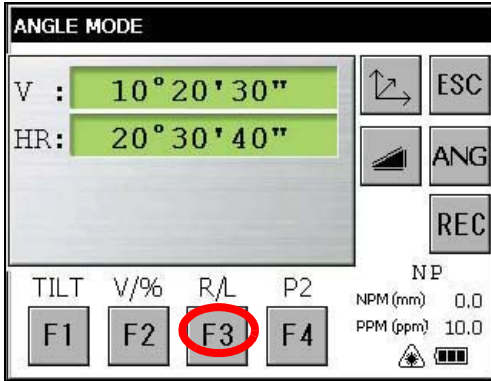

- 1 Press the [F4] key to get the function as on page 2.
- 2 Press the [F3] key.
The mode Horizontal angle Right(HR) switches to angle Left(HL) mode.

- 3 Measure the target in the same manner as HR mode.

- Every time pressing the [F3] key is pressed, HR/HL mode switches.

Reference : How to Collimate

- 1 Point the telescope toward the light. Turn the diopter ring and adjust the diopter so that the cross hairs are clearly observed.
(Turn the diopter ring toward you first and then backward to focus.)
- 2 Aim the target at the peak of the triangle mark of the sighting collimator. Allow a certain space between the sighting collimator and yourself for collimating.
- 3 Focus the target with the focusing knob.

*If parallax is created between the cross hairs and the target when viewing vertically or horizontally while looking into the telescope, focusing is incorrect or diopter adjustment is poor. This adversely affects precision in measurement or survey. Eliminate the parallax by carefully focusing and using diopter adjustment.

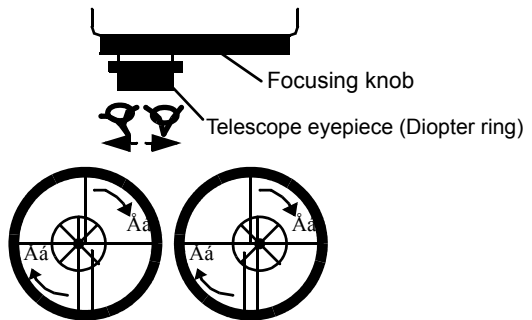

3.1.3 Measuring from the Required Horizontal Angle

1) Setting by Holding the Angle

Make sure the mode is angle measurement.

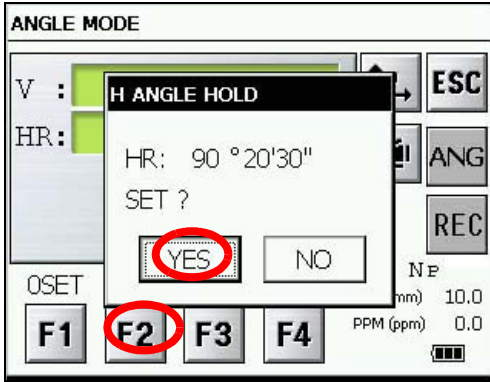

- 1 Set the required horizontal angle, using Horizontal tangent screw.
Example : 90°20'30"
- 2 Press the [F2] (HOLD) key.
- 3 Collimate the target.*1)
- 4 Press the [YES] key to finish holding the horizontal angle.
The display turns back to normal angle measurement mode.

*1)To return to the previous mode, press the [NO] key.

2) Setting a Horizontal Angle from the Keys

Make sure the mode is angle measurement.

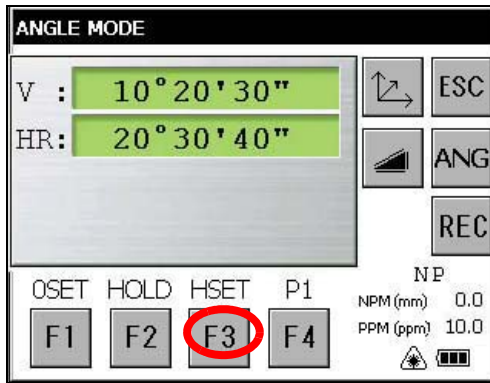

- 1 Collimate the target.
- 2 Press the [F3] key.

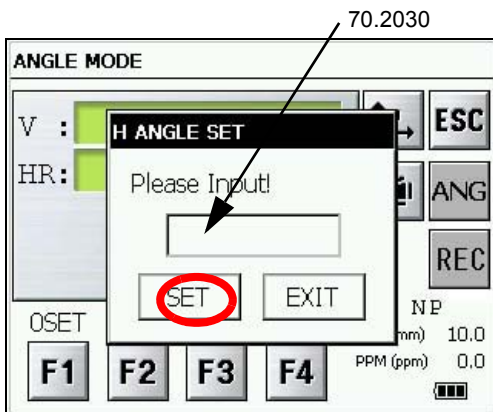

- 3 Input the required horizontal angle.
For example:70°20'30"
Input 70.2030
- 4 Press the [SET] key. *1)
When completed, normal measuring from the required Horizontal angle is possible.

*1)With wrong input value(for example 70'), setting will not be completed. Input again from step 3.

3.1.4 Vertical Angle Percent Grade(%) Mode

Make sure the mode is angle measurement.

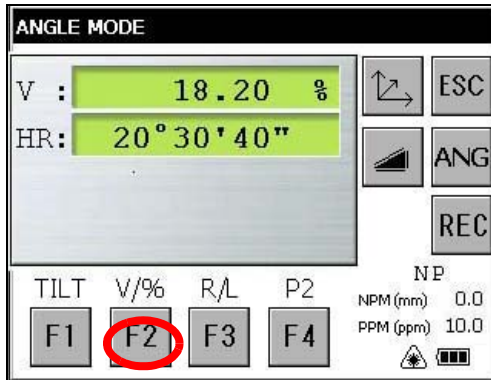

1 Press the [F4] key to get the function as on page 2.

2 Press the [F2] key. *1)

*1) Every time pressing the [F2] key, the display mode switches.

3.2 Distance Measurement

Note: Those distance shorter than 1m and 400m or more will not be displayed in Non-prism mode.
 Those distance shorter than 4.5m and 2010m or more will not be displayed in Non-prism long mode.

- Prism mode and Non-prism mode (Only for GPT-7500)**

In GPT-7500 series, the distance measurement will be done using invisible pulse laser beam emitted from pulse laser diode. You can select measurement mode between Prism mode which collimating a prism and Non-prism mode, Non-prism long mode that is collimating a target object except prism.

- For measurement with a prism, be sure to measure with the prism mode. If you measure with the non-prism mode and non-prism long mode accuracy cannot be guaranteed.
- Non-prism mode and non-prism long mode enable all distance measurements such Distance measurement, Coordinate measurement, Offset measurement and Layout.
- To switch over Prism mode to Non-prism mode or Non-prism long mode, press the [NP/P] soft key in each measurement display. [NP] of Non-prism mode indicator will be shown at the right corner of the display in Non-prism mode measurement. (or [LNP] of Non-prism long mode indicator will be shown.)
 Changing mode shall be done before measurement.

Example Distance measurement mode

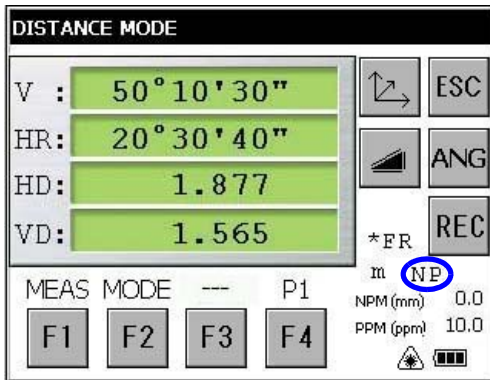

Coordinate measurement mode

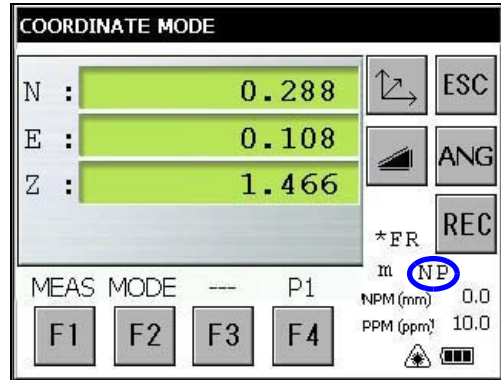

Non-prism mode indicator

- When using a reflection sheet, measure with the prism mode.
- It is possible to set Non-prism mode or Non-prism long mode for distance measurement during the power on time.
- If happened collimating the near distance prism in Non-prism mode or Non-prism long mode, measurement will not be done because of too much light.

- Precautions for Use of Non-prism long mode

GPT-7500 series made non-prism measurement possible to reach the distance that had never been achieved before.

In the non-prism long mode, the following attentions need to be paid because the farther the target object be, the weaker the reflection from the target and the larger the beam diameter become.

1) Measurement Time

In the non-prism long mode, the measuring time largely depends on a distance to the target object and the color (or reflectance) of the object. Especially when the measurement distance is far, or when the reflectance of the measured surface is low, measuring time will become longer.

2) Beam Diameter

Beam diameter becomes large in the long distance. Try to bring as much beam as possible to the measured surface.

If the beam is not lased rightly as in the cases below, may cause incorrect measurement.

In such cases, collimate the position where the beam is not fallen besides the measured surface, set measurement distance range (Chapter 3.2.3 “Setting Measurement distance range of Non-prism long mode”).

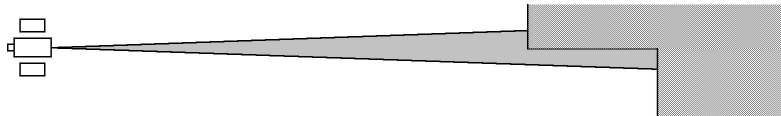

(e.g.1) the beam also reaches the wall either before or behind the object

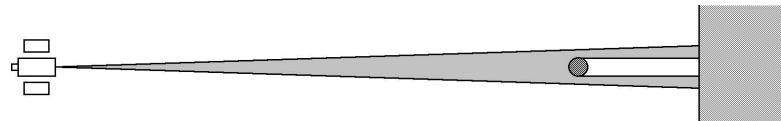

(e.g.2) the beam reaches the wall behind due to the size of the object

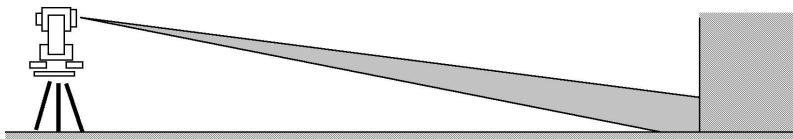

(e.g.3) the beam is thrown on the ground before the object

3) Cutoff during Measurement

While in the Non-prism long mode, you had better use the instrument in the place where the light path may not be cut off by cars or people. You may not be able to collect accurate figures if it is often cut off.

4) Re-measuring

When the reflectance of the measured surface drastically changes as in the case of looking quickly from the white object to the black object, or when the distance to the object changes a lot, you may face a temporary suspension. If you cannot measure even after a while, press [MEAS] or [MODE] key to restart measurement.

3.2.1 Setting of the Atmospheric Correction

When setting the atmospheric correction, obtain the correction value by measuring the temperature and pressure.

Setting the atmospheric correction, see Chapter 8 "SETTING ATMOSPHERIC CORRECTION" .

3.2.2 Setting of the Correction for Prism Constant

Topcoat's prism constant value is 0. Set correction for prism at 0. If the prism is of another manufacture, the appropriate constant shall be set beforehand.

Setting the prism / non-prism constant value, see Chapter 7 "SETTING THE PRISM / NON-PRISM CONSTANT VALUE" . The setting value is kept in the memory even after power is off.

Note: Confirm that Non-prism correction value is set at zero before measurement target such as a wall in Non-prism mode.

3.2.3 Setting Measurement distance range of Non-prism long mode (Only for GPT-7500)

To set measurement distance range, carry out the following operating procedure.

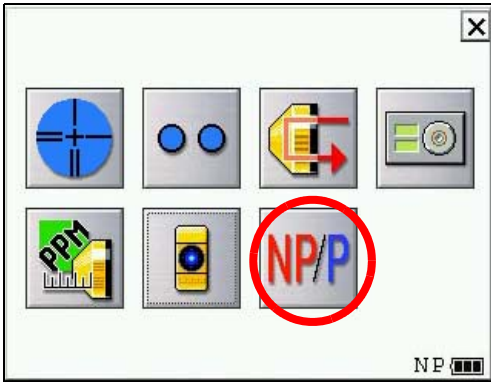

- 1 Press the star [★] key.
- 2 Press the [NP/P] key.

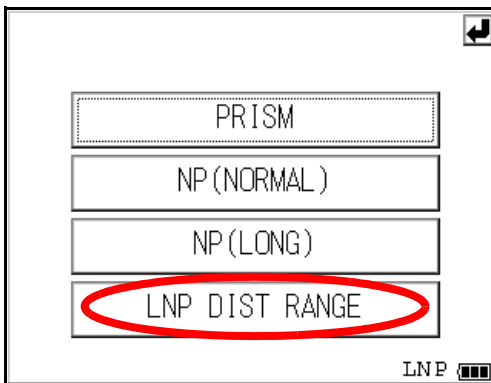

- 3 Press the [LNP DIST RANGE] key.

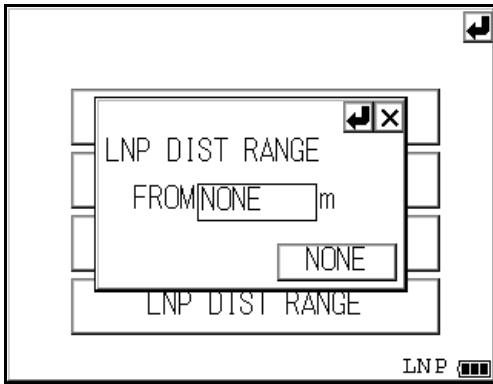

- 4 Input the distance range by pressing the numeric key. *1)

Example: 10m

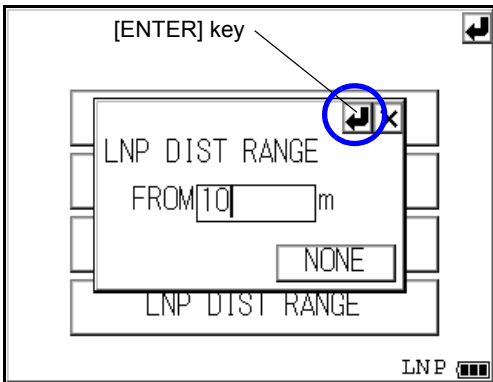
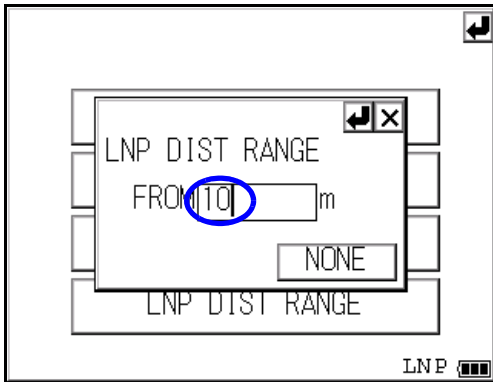

- 5 Press the [ENTER] key.

The display returns to the star key mode.

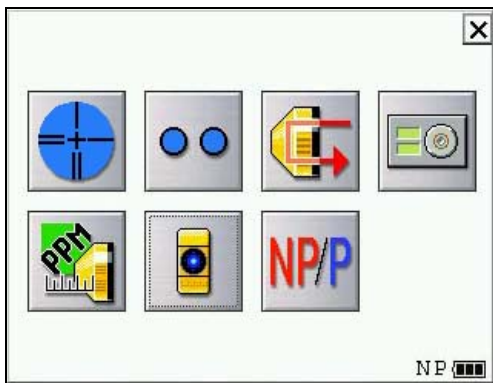

*1) Input range: 5 m ~ 1,800 m (17 ft. ~ 5,900 ft.)

3.2.4 Distance Measurement (Continuous Measurement)

Make sure the mode displays angle measurement.

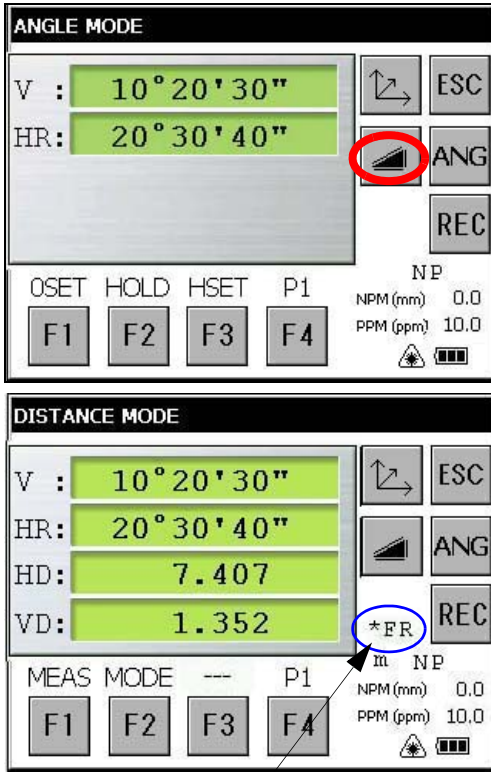

- 1 Collimate the center of prism.
- 2 Press the [] key.
*1),*2)

[Example]:
Horizontal distance / Relative elevation mode

The result are shown.*3) ~ *7)

*1)The following characters will be shown on the 4th line right hand of the display to represent measurement mode.

F=Fine; C=Coarse; t=Tracking ; R=Continuous (Repeat); S=Single; N=N-times

*2)When EDM is working, the " *" mark appears in the display.

*3)The result is shown with buzzer sound.

*4)Measurement may repeat automatically if the result is affected by shimmer etc..

*5)To change single measuring, press the [F1] key.

*6)To change SD/HD&VD, press the [] key.

*7)To return to the angle measurement mode, press the [ANG] key.

3.2.5 Distance Measurement (Single/N-times Measurement)

When presetting the number of times, the instrument measures the distance as the setting times and the average distance will be displayed.

When presetting the number of times as 1 or 0, it does not display the average distance, because of single measurement. It has been set at single measurement at factory.

1)Setting the number of times

Refer to Chapter 5 "PARAMETERS SETTING MODE" .

2)Measuring Method

Confirm the angle measurement mode.

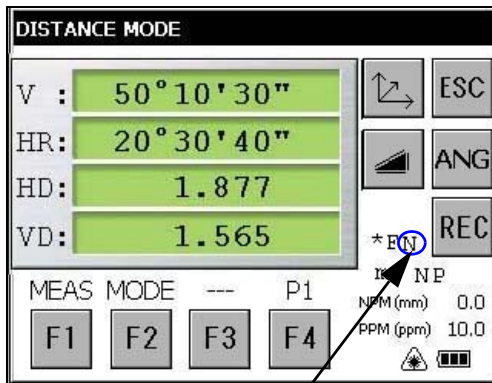
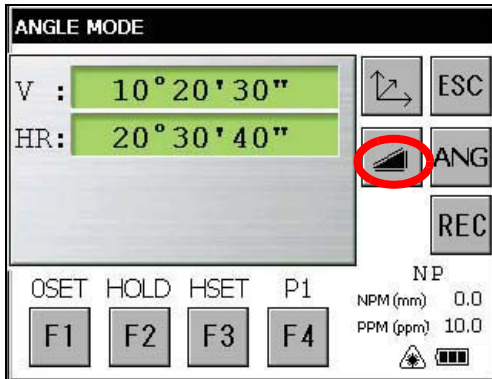

*1)

- 1 Collimate the center of the prism.
- 2 Select the measurement mode by pressing the [] key.
Example:
Horizontal distance / Relative elevation mode

N-times measurement starts.

The average value is displayed following with buzzer sound.

*1)The following characters will be shown on the 4th line right hand of the display to represent measurement mode.

R=Continuous (Repeat); S=Single; N=N-times

3.2.6 Fine / Coarse / Tracking Measuring Mode

GTS-750

- Fine mode : This is a normal distance measuring mode.
Measurement time 0.2mm mode : approx.2.8 seconds
1 mm mode : approx.1.2 seconds
The unit to be displayed is 0.2mm or 1mm. (0.001ft or 0.005ft)
- Coarse mode : This mode measures in shorter time than in fine mode.
Use this mode for the objects which may be slightly unstable.
Measurement time : approx. 0.7seconds
The unit to be displayed is 1mm or 10mm. (0.005ft or 0.02ft)
- Tracking mode : This mode measures in shorter time than in fine mode.
Use this mode for stake out measurement. It is very useful when tailing the moving object or carrying out stake-out work.
Measurement time : approx. 0.4 seconds
The unit to be displayed is 10mm. (0.02ft)

GPT-7500

Prism Mode

- Fine mode : This is a normal distance measuring mode.
Measurement time 0.2mm mode : approx.3 seconds
1 mm mode : approx.1.2 seconds
The unit to be displayed is 0.2mm or 1mm. (0.001ft or 0.005ft)
- Coarse mode : This mode measures in shorter time than in fine mode.
Use this mode for the objects which may be slightly unstable.
Measurement time : approx. 0.5seconds
The unit to be displayed is 1mm. (0.005ft)
- Tracking mode : This mode measures in shorter time than in fine mode.
Use this mode for stake out measurement. It is very useful when tailing the moving object or carrying out stake-out work.
Measurement time : approx. 0.3 seconds
The unit to be displayed is 10mm. (0.02ft)

Non Prism Mode

- Fine mode : This is a normal distance measuring mode.
Measurement time 0.2mm mode : approx.3 seconds
1 mm mode : approx.1.2 seconds
The unit to be displayed is 0.2mm or 1mm. (0.001ft or 0.005ft)
- Coarse mode : This mode measures in shorter time than in fine mode.
Use this mode for the objects which may be slightly unstable.
Measurement time : approx. 0.5seconds
The unit to be displayed is 1mm. (0.005ft)
- Tracking mode : This mode measures in shorter time than in coarse 1mm mode.
Use this mode for stake out measurement. It is very useful when tailing the moving object or carrying out stake-out work.
Measurement time : approx. 0.3 seconds
The unit to be displayed is 10mm. (0.02ft)

Non Prism Long Mode

- Fine mode : This is a normal distance measuring mode.
Measurement time : approx. 1.5~6 seconds
The unit to be displayed is 1mm. (0.005ft)

- Coarse mode : This mode measures in shorter time than in fine mode.
Use this mode for the objects which may be slightly unstable.
Measurement time : approx. 1~3 seconds
The unit to be displayed is 5mm. (0.015ft)

- Tracking mode : This mode measures in shorter time than in coarse 5mm mode.
Use this mode for stake out measurement. It is very useful when tailing the moving object or carrying out stake-out work.
Measurement time : approx. 0.4 seconds
The unit to be displayed is 10mm. (0.02ft)



In the non-prism long mode, the measuring time largely depends on a distance to the target object and the color (or reflectance) of the object. Especially when the measurement distance is far, or when the reflectance of the measured surface is low, measuring time will become longer.

3 STANDARD MEASUREMENT MODE

- To select distance measurement mode
Confirm the distance measurement mode.

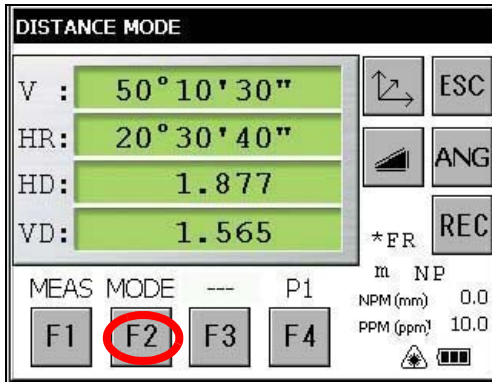

The first letter of the current mode is displayed.*1)

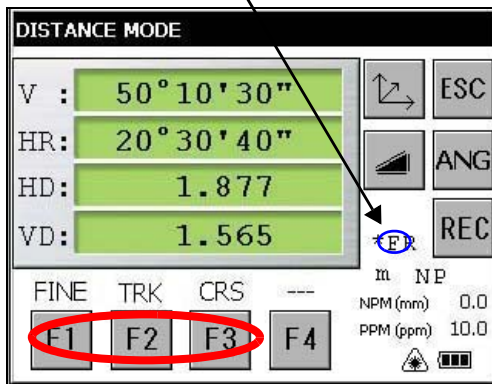

- Collimate the center of prism.
- Press the [F2] key.

- Select the measurement mode by pressing the [F1], [F2] or [F3] key. *2)

The mode is set and distance measuring mode reappears.

*1)The following characters will be shown on the 4th line right hand of the display to represent measurement mode.

F=Fine; C=Coarse; c=Coarse 10mm

*2)To cancel the setting, press the [ESC] key.

3.2.7 Stake Out (S.O)

The difference between the measured distance and the distance preset is displayed.

The displayed value = Measured distance - Standard (Preset) distance

Stake out operation can be performed for horizontal distance (HD), relative elevation (VD) or slope distance (SD).

[Example : Horizontal distance]

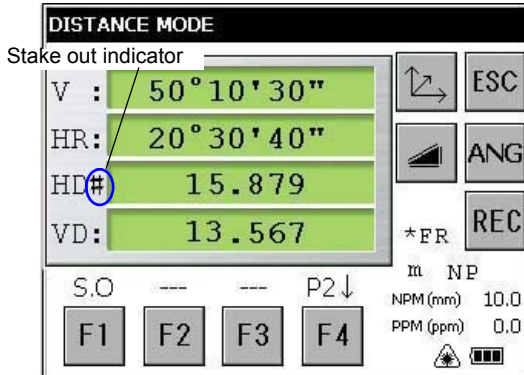
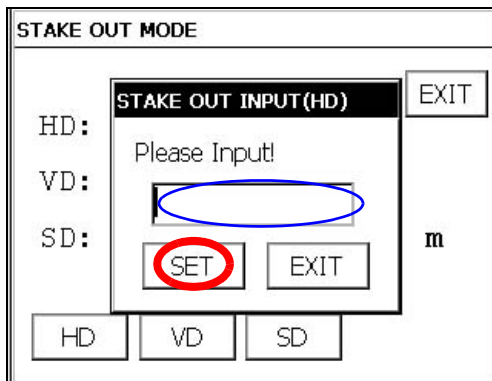
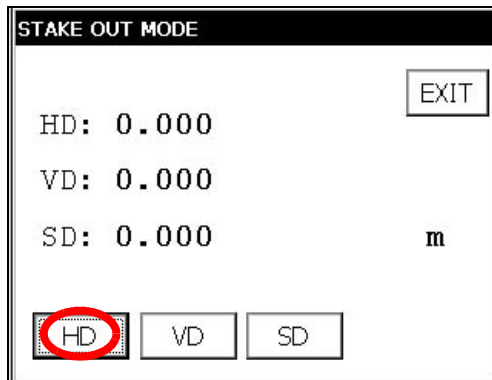
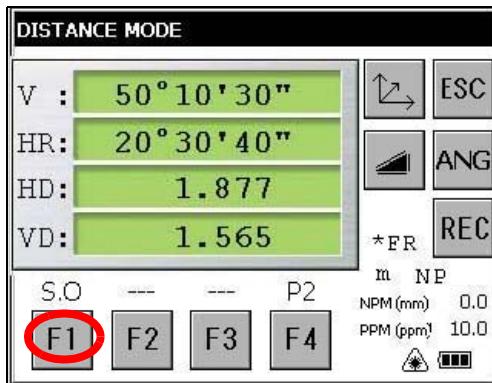

- 1 Press the [F4] key in the distance measurement mode to get the function as in page 2.
- 2 Press the [F1] key .
The current setting value is displayed.
- 3 With the [HD] - [SD] keys, select a mode for inputting the standard distance.
- 4 Enter the horizontal distance for stake out.
- 5 Press the [SET] key.
- 6 Press the [EXIT] key.
- 7 Collimate the Prism.
The difference between the measured distance and the standard distance is displayed.

- To return to normal distance measurement mode, reset the standard distance to " 0 " .

3.3 Coordinate Measurement

3.3.1 Setting Coordinate Values of Occupied Point

Set the coordinates of instrument (occupied point) according to coordinate origin, and the instrument automatically converts and displays the unknown point (reflector point) coordinates following the origin.

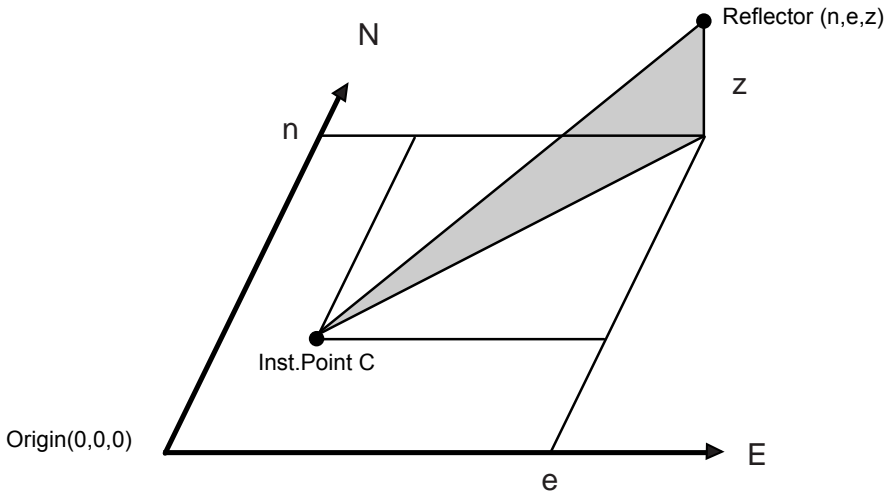

Confirm the angle measurement mode.

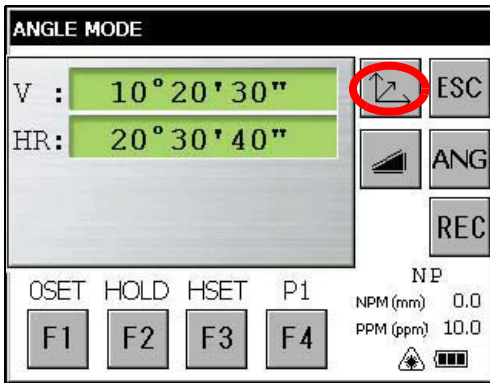

- 1 Press the [] key.
- 2 Press the [F4] key.

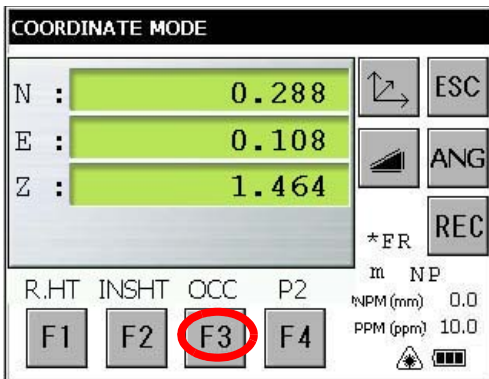

- 3 Press the [F3] key.
The previous data will be shown.

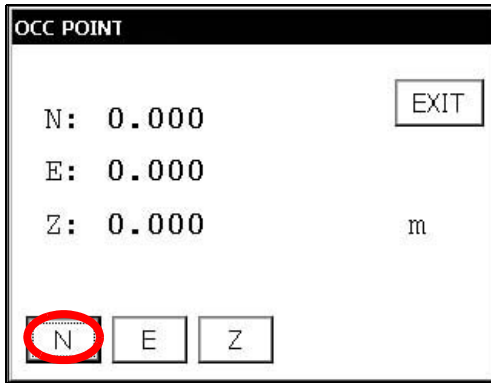

4 Press the [N] key.

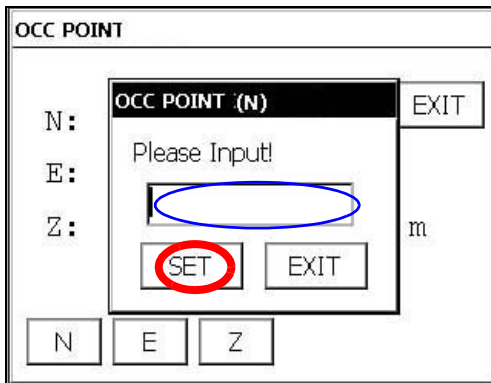

5 Input the N coord.

6 Press the [SET] key.*1)

7 Press the [E] key.

8 Input the E coord.

9 Press the [SET] key.*1)

10 Press the [Z] key.

11 Input the Z coord.

12 Press the [SET] key.*1)

13 Press the [EXIT] key.

The display returns to coordinate measurement mode.

*1)To return to the previous mode, press the [EXIT] key.

3.3.2 Setting of the Instrument Height / Reflector(Prism) Height

Measure the coordinates by entering the instrument height / reflector height, coordinates of unknown point will be measured directly.

[Example] : Instrument height

Confirm the angle measurement mode.

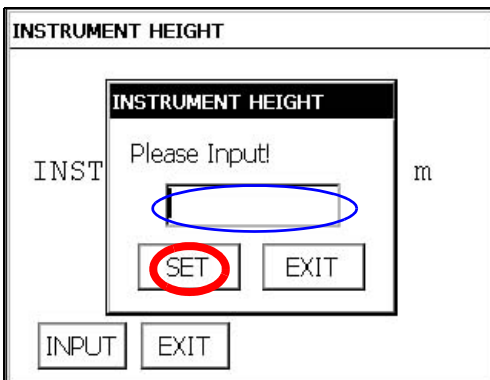
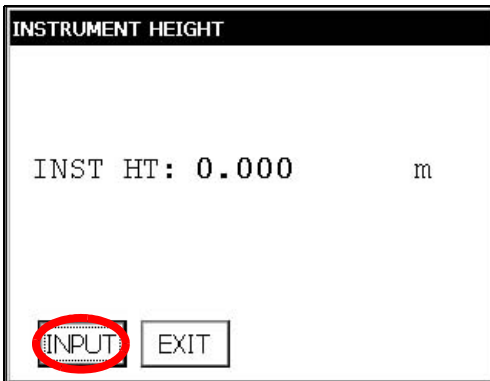
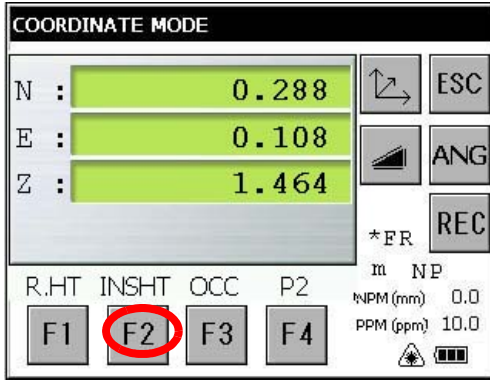

- 1 Press the [\angle] key.
- 2 Press the [F4] key to get the function as in page 2.
- 3 Press the [F2] key .
The previous data will be shown.

- 4 Press the [INPUT] key.

- 5 Input instrument height, and press [SET] key.*1)
- 6 Press the [EXIT] key.

The display returns to coordinate measurement mode.

*1)To return to the previous mode, press the [EXIT] key.

3.3.3 Execution of Coordinate Measuring

Measure the coordinates by entering the instrument height and reflector height, coordinates of unknown point will be measured directly.

- When setting coordinate values of occupied point, see section 3.3.1“Setting Coordinate Values of Occupied Point” .
- When setting the instrument height and reflector height, see section 3.3.2“Setting of the Instrument Height / Reflector(Prism) Height” .
- The coordinates of the unknown point are calculated as shown below and displayed:

Coordinates of occupied point : (N_0, E_0, Z_0)
 Instrument height : INST.HT
 Reflector height : R.HT
 Vertical distance(Relative elevation) : z
 Coordinates of the center of the reflector,
 originated from the center point of the instrument : (n, e, z)
 Coordinates of unknown point : (N_1, E_1, Z_1)
 $N_1 = N_0 + n$
 $E_1 = E_0 + e$
 $Z_1 = Z_0 + \text{INST.HT} + z - \text{R.HT}$

Coordinates of the center of the reflector, originated from the center point of the instrument (n, e, z)

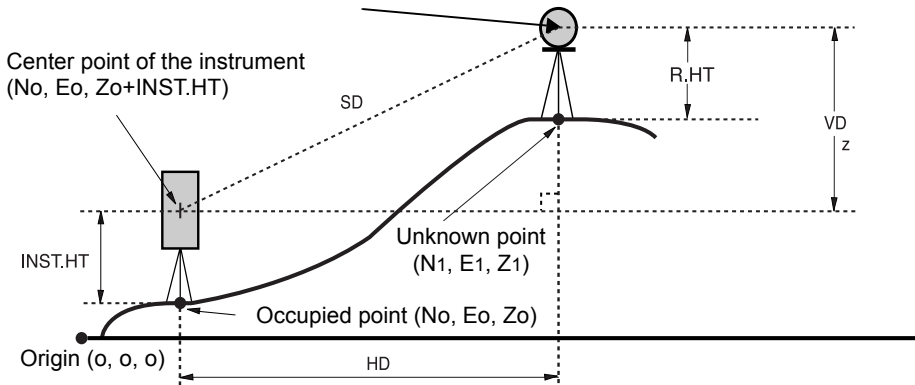

Confirm the angle measurement mode.

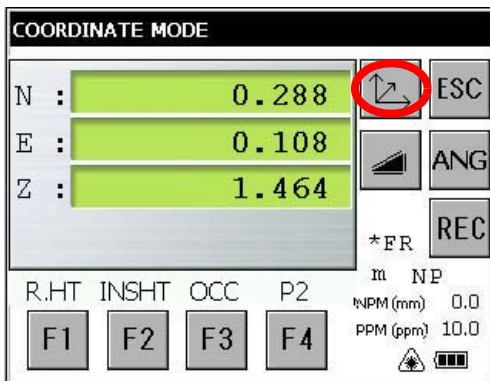

- 1 Set coordinates values of occupied point and instrument/reflector height. *1)
- 2 Set the direction angle of known point A. *2)
- 3 Collimate the reflector.
- 4 Press the [] key. Measuring starts.

*1) In case the coordinate of occupied point is not entered, (0,0,0) will be used as the default for the occupied point.

The instrument height will be calculated as 0 when the instrument height is not entered.

The reflector height will be calculated as 0 when the reflector height is not set.

*2) Refer to section 3.1.3“Measuring from the Required Horizontal Angle” .

3.4 Data Output

Result of measurement is transferred from the GTS-750/GPT-7500 series to Data Collector.

[Example: Distance measurement mode]

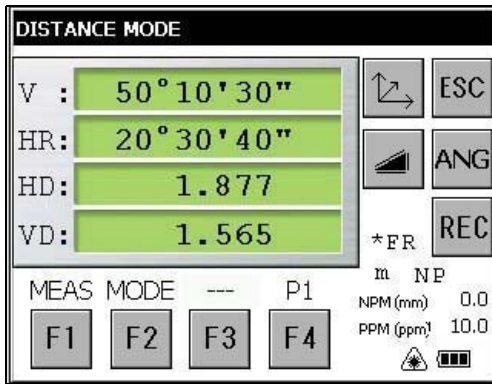
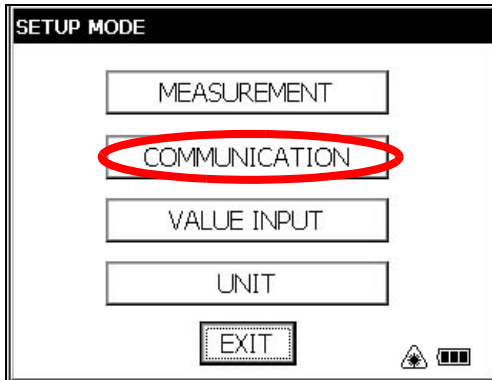

- 1 With the SETUP mode, set the communication parameters.

Refer to Chapter 5 “PARAMETERS SETTING MODE” .

- 2 After setting the communication parameters, select the distance measurement mode.

- 3 Operate the data collector to measure the distance.

Measurement will be started.

After the measurement, the result will be shown and transferred to the Data Collector.

The following data will be output at each mode.

Mode	Output
Angle mode (V,HR or HL) (V in percent)	V, HR (or HL)
Horizontal distance mode (V,HR, HD, VD)	V, HR, HD, VD
Slope distance mode (V, HR,SD)	V, HR, SD,HD
Coordinate mode	N, E, Z, HR

- The display and the output at the coarse mode are the same as the contents above.
- Output at the tracking mode is displayed as distance data only (HD,VD or SD).

3.5 Data Output by [REC] Key

It is also possible to output the result of measurement by pressing the [REC] key .

[Example: Distance measurement mode]

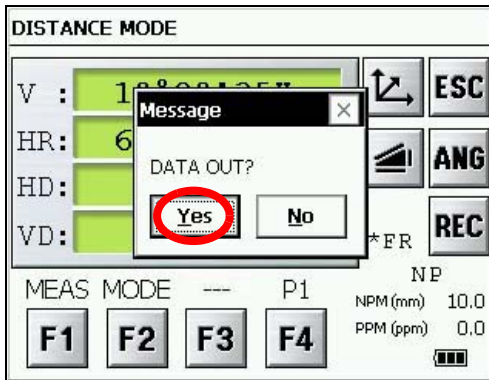
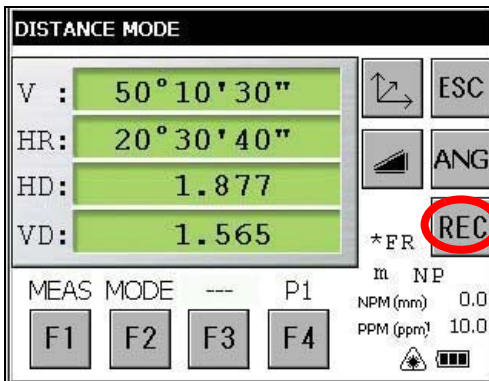
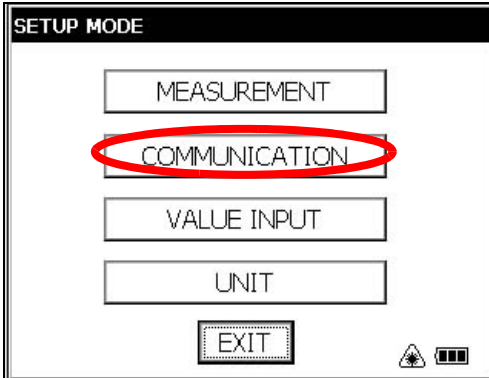

- 1 With the SETUP mode, set the communication parameters.

Refer to Chapter 5 "PARAMETERS SETTING MODE" .

- 2 After setting the communication parameters, select the distance measurement mode.

- 3 Press the [REC] key.

Measurement will be started.

- 4 After the measurement, press the [Yes] key.

The data will be transferred to the Data Collector.

4 PROGRAM MODE

Select the menu by pressing panel icon.

Main menu

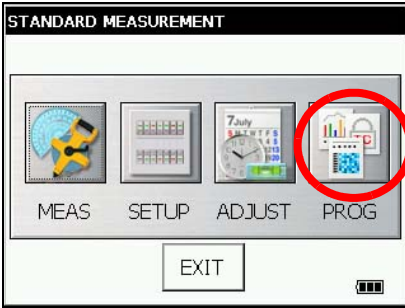

Press the [PROG] icon.

Program mode menu

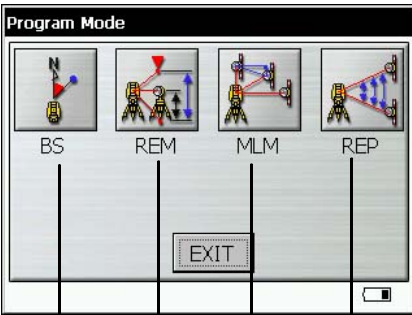

Repetition angle measurement

Refer to Chapter 4.4 "Repetition Angle Measurement (REP)".

Missing line measurement

Refer to Chapter 4.3 "Missing Line Measurement (MLM)".

Remote elevation measurement

Refer to Chapter 4.2 "Remote Elevation Measurement (REM)".

Setting a direction angle for backsight orientation

Refer to Chapter 4.1 "Setting a Direction Angle for Backsight Orientation(BS)".

4.1 Setting a Direction Angle for Backsight Orientation(BS)

(Entering the instrument and backsight coordinate values)

This program uses the input coordinate values of the occupied point, (instrument), and backsight point to calculate the backsight orientation direction angle.

The occupied and backsight coordinate input display appears.

After the coordinate values are entered for both points, the instrument calculates the backsight direction angle for orientation.

Also the occupied coordinate values are stored in memory. The program does not store the backsight coordinate values in memory.

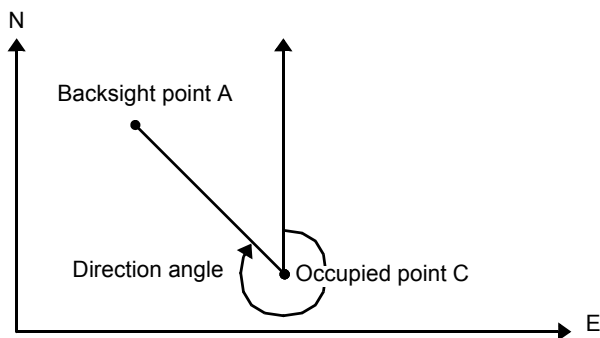

Example: Occupied point C : N coordinate 5.321m, E coordinate 8.345m
 Backsight point A : N coordinate 54.321m, E coordinate 12.345m

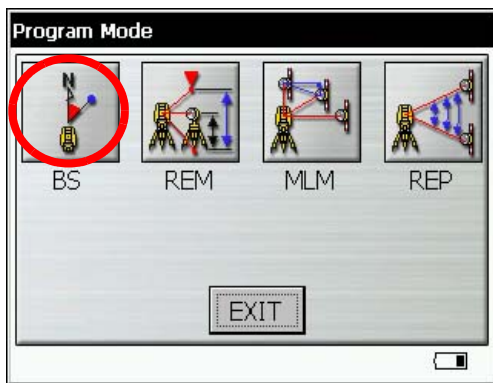

1 Press the [BS] icon.

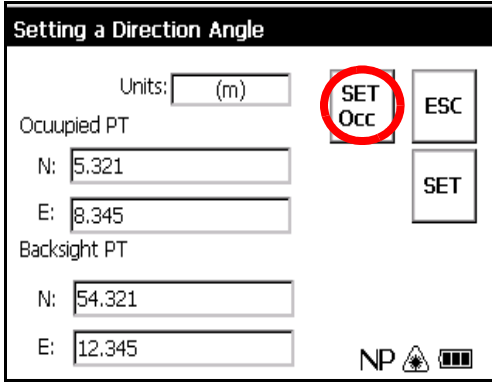

2 Input N and E coordinate of occupied point C.

Example : N coordinate; 5.321m
: E coordinate; 8.345m

3 Input N and E coordinate of backsight point A.

Example : N coordinate; 54.321m
: E coordinate; 12.345m

4 To memorize the occupied point, press the [SET OCC] key.

5 Press the [YES] key.

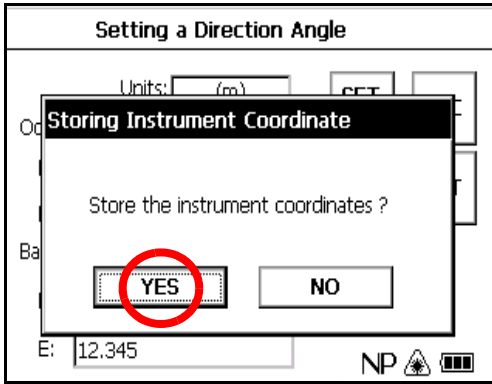

6 Press the [SET] key.

7 Collimate the backsight.

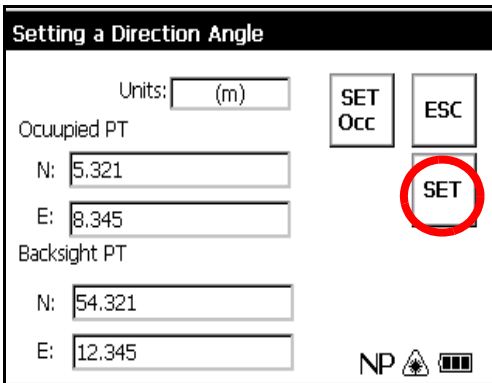

8 Press the [YES] key.

The display returns to Program mode menu.

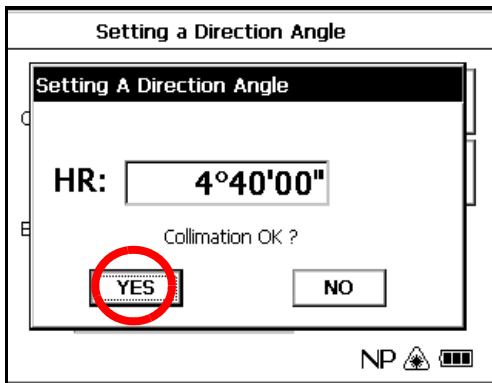

4.2 Remote Elevation Measurement (REM)

The Remote Elevation program calculates the vertical distance (height) of a remote object relative to a prism and its height from a ground point, (without a prism height). When using a prism height, the remote elevation measurement will start from the prism (reference point). If no prism height is used, the remote elevation will start from any reference point in which the vertical angle is established. In both procedures, the reference point should be perpendicular to the remote object.

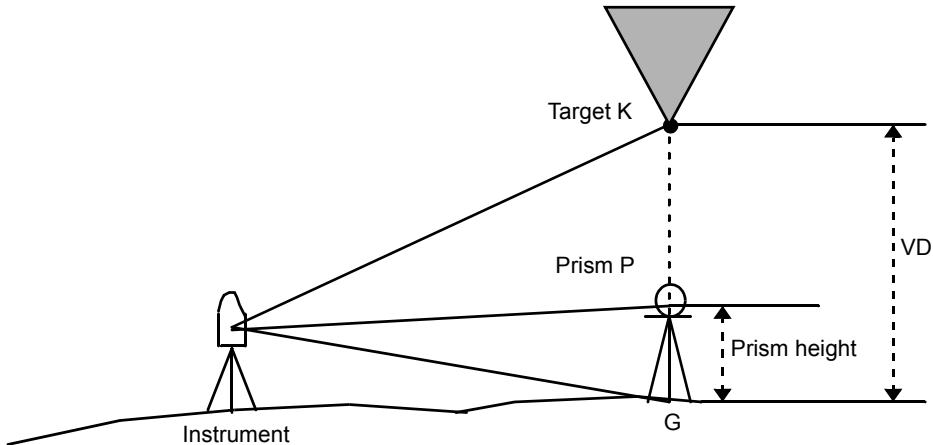

1) With prism height input

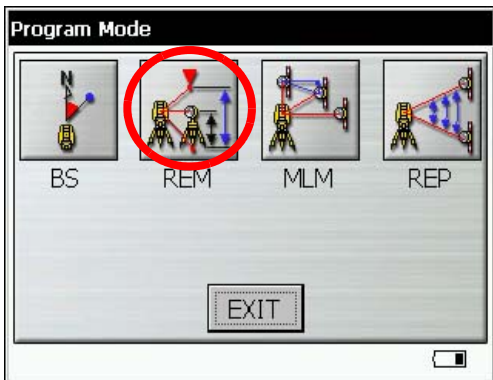

1 Press the [REM] icon.

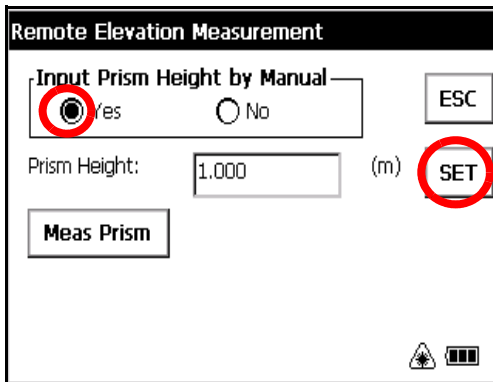

2 Select the [YES] button.

3 Input the Prism Height. (Example;1.000m)

4 To memorize the prism height, press the [SET] key.

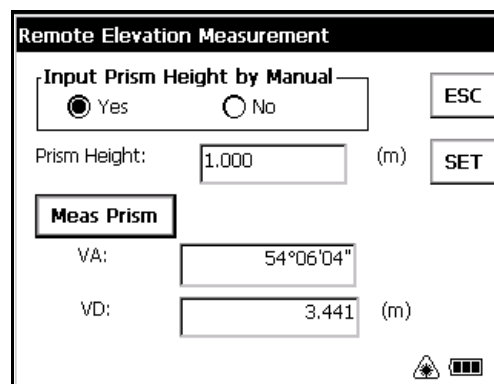
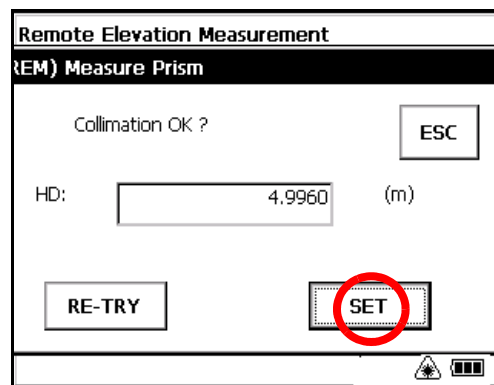
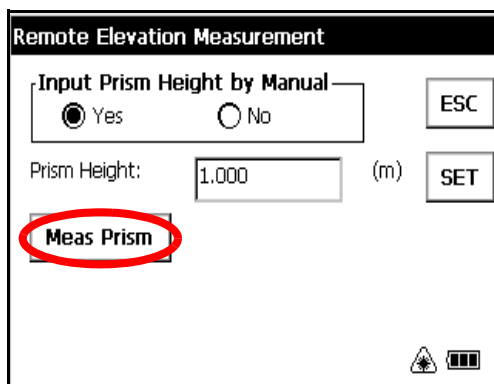
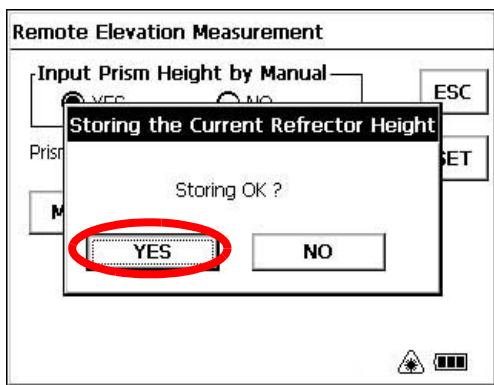

5 Press the [YES] key.

6 Collimate prism.

7 Press the [Meas Prism] key.

8 Press the [SET] key.

(To measure the distance again, press the [RE-TRY] key.)

9 Collimate target K.

Vertical angle(VA) and Vertical distance(VD) will be shown.

2) Without prism height input



1 Press the [REM] icon.

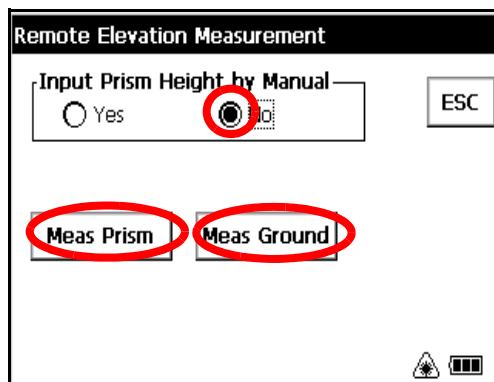

2 Select the [NO] button.

3 Collimate prism.

4 Press the [Meas Prism] key.

5 Press the [SET] key.

6 Collimate ground point G.

7 Press the [Meas Ground] key.

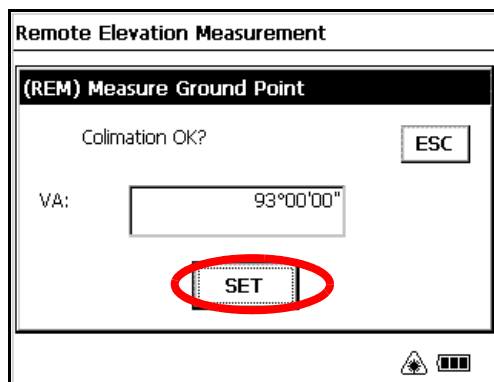

8 Press the [SET] key.

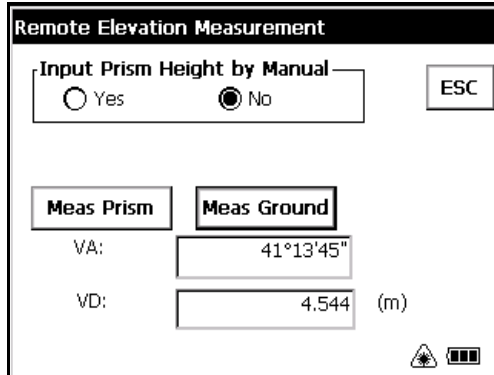

9 Collimate target K.
Vertical angle(VA) and Vertical distance(VD)
will be shown.

4.3 Missing Line Measurement (MLM)

The Missing Line Measurement program calculates the horizontal distance (dHD), slope distance (dSD) and elevation (dVD) between two target prisms.

The instrument can accomplish this in two ways:

MLM Method (A-B, A-C): Measurement is A-B, A-C, A-D,

MLM Method (A-B, B-C): Measurement is A-B, B-C, C-D,

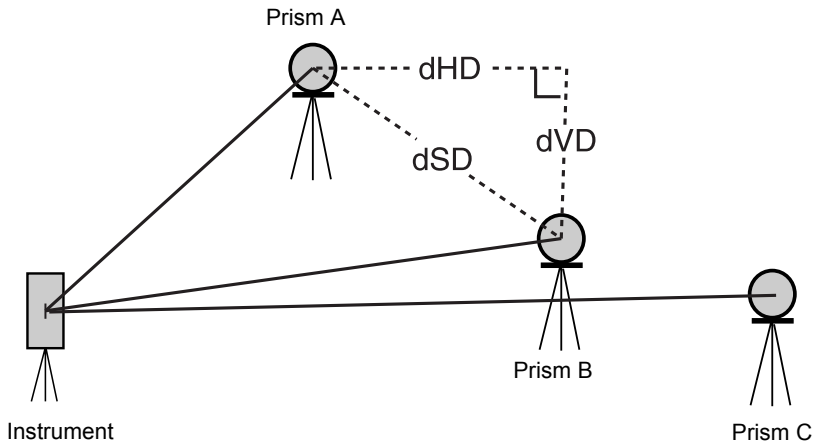

[Example] MLM Method (A-B, A-C)

Procedure of MLM Method (A-B, B-C) is completely same as Method (A-B, A-C) Method.

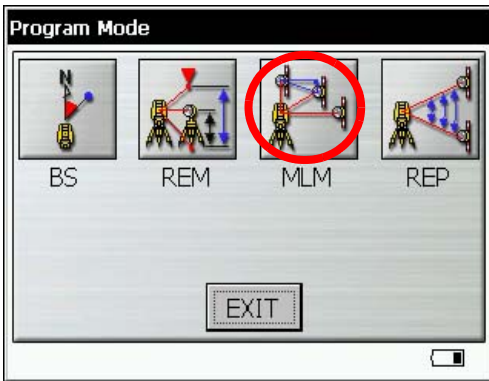

1 Press the [MLM] icon.

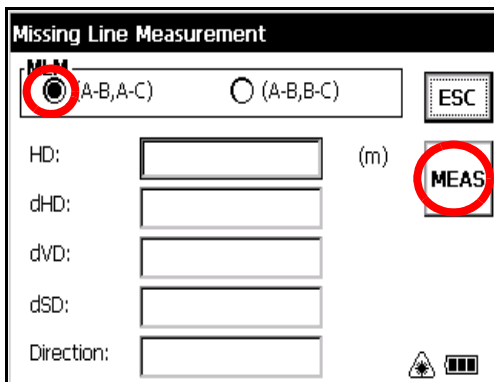

2 Select the [(A-B, A-C)] button.

3 Collimate prism A.

4 Press the [MEAS] key.
Horizontal distance between the instrument and prism A will be shown.

Missing Line Measurement

MLM (A-B,A-C) (A-B,B-C) ESC



HD: (m) MEAS

dHD:

dVD:

dSD:

Direction:

- 5 Collimate prism B, and press the [MEAS] key. Horizontal distance between the instrument and prism B will be shown.

Missing Line Measurement

MLM (A-B,A-C) (A-B,B-C) ESC



HD: (m) MEAS

dHD:

dVD: 1

dSD: <- ->

Direction: RESET

And then, the horizontal distance (dHD), relative elevation (dVD) and slope distance (dSD) between prism A and B will be shown.

Missing Line Measurement

MLM (A-B,A-C) (A-B,B-C) ESC



HD: (m) MEAS

dHD:

dVD: 2

dSD: <- ->

Direction: RESET

- 6 To measure the distance between points A and C, repeat procedure 5.

- To confirm the previous data, press the [←] or [→] key.
- To clear all data, press the [RESET] key.

4.4 Repetition Angle Measurement (REP)

Repetition Angle Measurement program calculates horizontal angles and shows the total angle (Ht) and the mean (Hm) of all the angles measured. The program also keeps track of the amount of complete sets of horizontal angles measured.

Repetition Angle Measurement program can be done by horizontal angle right measurement mode.



1 Press the [REP] icon.

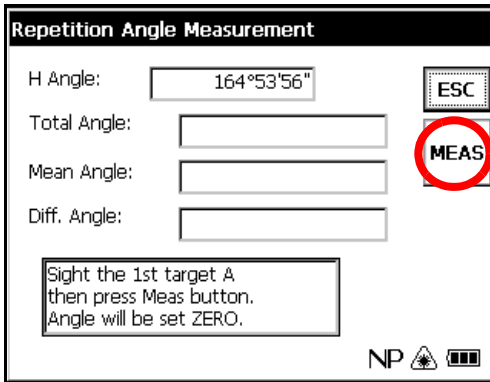

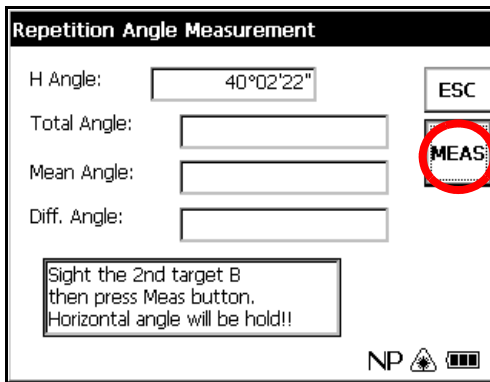

2 Collimate the first target A.

3 Press the [MEAS] key.



4 Collimate the second target B.

5 Press the [MEAS] key.

Repetition Angle Measurement	
H Angle:	<input type="text" value="40°02'22"/> <input type="button" value="ESC"/>
Total Angle:	<input type="text" value="40°02'22"/> <input type="button" value="MEAS"/>
Mean Angle:	<input type="text" value="40°02'22"/> <input type="button" value="1"/>
Diff. Angle:	<input type="text" value="0°00'00"/> <input type="button" value="RESET"/>
<div style="border: 1px solid black; padding: 5px; width: fit-content;"> Sight the 1st target A then press Meas button. Horizontal angle will be released!! </div>	
NP  	

The total of angle and the mean of angle are shown.

- 6** Repeat procedure **2 ~ 5** to measure the desired number of repetitions.

- Horizontal angle can be accumulated up to 99 times.
- To clear all data, press the [RESET] key.

5 PARAMETERS SETTING MODE

PARAMETERS SETTING MODE

In this mode, setting of parameters regard with measuring and communications will be done. When a parameter is changed and set, the new value is stored into the memory.

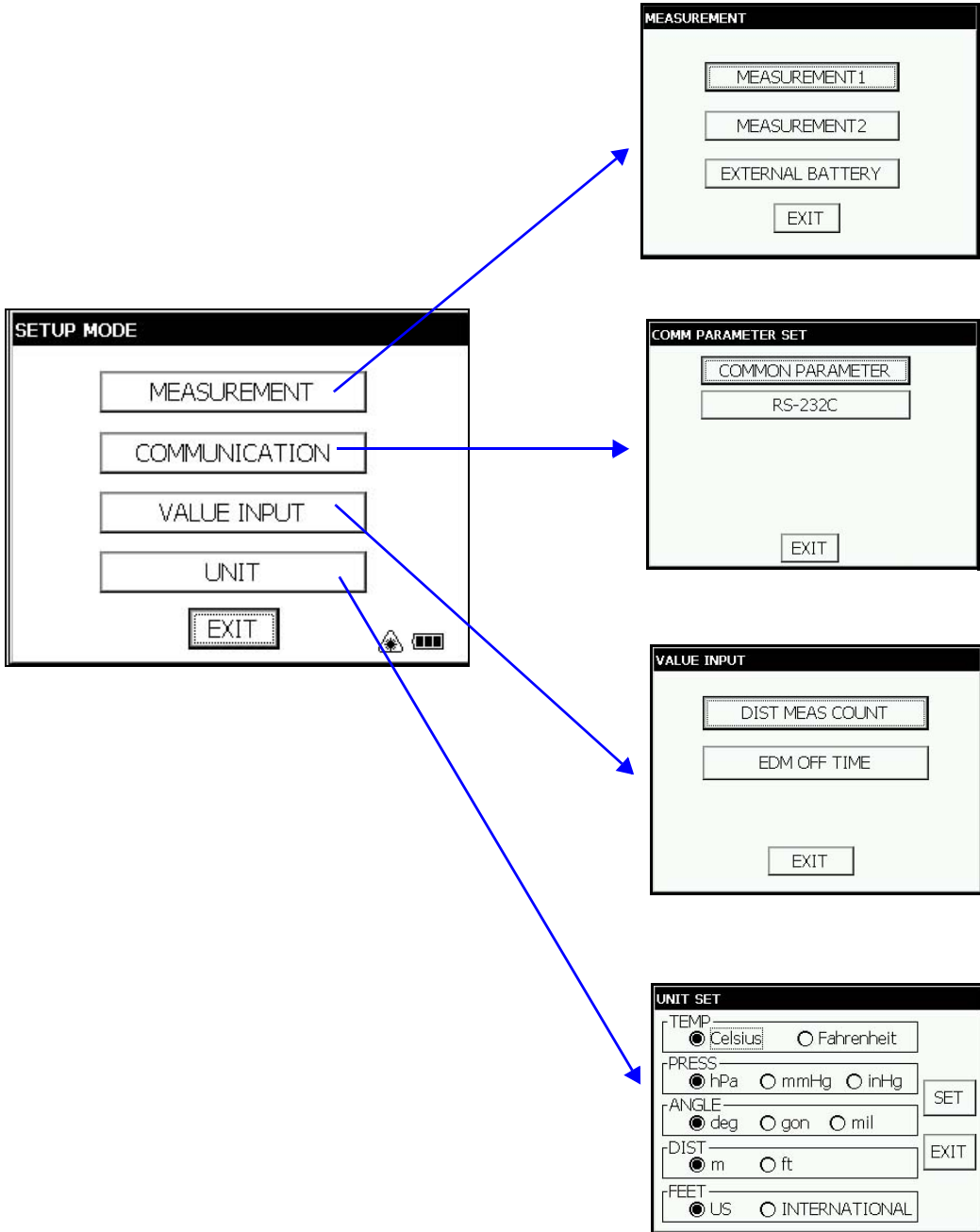

5.1 Parameter Setting Options

5.1.1 Measurement

Menu	Selecting Item	Contents
MEASUREMENT 1		
MINI ANG READING	NORM / MINI	Select the minimum display angle reading unit.
FINE READING	1mm / 0.2mm	Select 1mm/0.2mm for the minimum distance in fine mode.
TILT	OFF/X-ON/XY-ON	Select the tilt sensor option for OFF, X-ON, XY-ON.
3AXIS COMPENSATION	OFF/ON	Select the error correction ON or OFF for collimation and error adjustment. Perform this item after complete Chapter 6.5 "Compensation Systematic Error of Instrument". For more information, refer to Chapter 6.3.6 "Adjustment of Vertical Angle 0 Datum" and Chapter 6.5.2 "Showing Compensation Systematic Error of Instrument".
CRS READING	10mm / 1mm (Prism/Non-Prism mode) 10mm / 5mm (Non-Prism long mode)	Select 10mm/1mm (or 10mm/5mm) for the minimum distance in coarse mode.
POWER ON MODE	ANGLE/DIST	Select the measuring mode when the power is on to angle measurement or distance measurement.
DIST MODE	FINE/CRS/TRK	After turning on the power, select the same measuring mode (FINE/CRS/TRK) as when distance measurement was initially carried out.
DIST DISPLAY	HD&VD/SD	After turning on the power, select the same measuring mode (HD&VD/SD) as when distance measurement was initially carried out.
V ANGLE Z0/H0	ZENITH/ HORIZONTAL	Select the vertical angle reading for Zenith 0 or Horizontal 0.
DIST MEAS NUMBER	REPEAT/N TIME	After turning on the power, select the same measuring mode (REPEAT/N TIME) as when distance measurement was initially carried out.
NEZ / ENZ	NEZ / ENZ	Select the display format in the coordinate measurement mode for NEZ or ENZ.
W CORRECTION	OFF/0.14/0.20	Select the coefficient correction for refraction and earth curvature. Selections for the refraction coefficient are; OFF (No correction), K=0.14 or K=0.20.
S/A BUZZER	OFF/ON	Select the Audio tone OFF or ON for the Set Audio Mode.
MEASUREMENT 2		
START MODE	NORMAL/ STD MEAS/	Select the start mode.
EXTERNAL BATTERY		
	Li-ion/12V BATTERY	Select the external battery type.

5.1.2 Communication

Factory default settings are indicated with underlines.

Menu	Selecting Item	Contents
COMMON PARAMETER		
RECKey Data Out	<u>RS232C</u>	Select communication route for REC key data output.
NEZ REC FORM	<u>STANDARD</u> /WITH RAW	Select to record coordinates in standard or 11 digits with raw data.
REC TYPE	<u>REC-A</u> /REC-B	Select the option to record the data. REC-A :The measurement is started and new data is output. REC-B :The data being displayed is output.
RS-232C		
BAUD RATE	<u>1200</u> / 2400 / 4800 / 9600/19200	Select the baud rate.
DATA LENGTH	<u>7 BIT</u> / 8BIT	Select the data length seven digits or eight digits.
PARITY BIT	NON/ <u>EVEN</u> /ODD	Select the parity bit.
STOP BIT	<u>1 BIT</u> / 2BIT	Select the stop bit.
CR, LF	<u>OFF</u> /ON	Select the option OFF or ON for carriage return and line feed when collecting measurement data with a computer.
ACK MODE	OFF/ <u>ON</u>	When communicating to an external device, the protocol for handshaking can omit the [ACK] coming from the external device so data is not sent again. OFF : Omit the [ACK] ON : Standard

5.1.3 Value Input

Menu	Selecting Item	Contents
DIST MEAS COUNT SET	0~99	N-times measurement set. Set N (number of times) for times of distance measurement. When setting number of times as 1 or 0, it is single measurement.
EDM OFF TIME SET	0~99	The time when EDM is cut off from distance measurement is completed can be changed. 0 : After completing distance measurement, EDM is cut off. 1-98 : EDM is cut off after 1~98 minutes. 99 : EDM is always switched ON.

5.1.4 Unit

Menu	Selecting Item	Contents
TEMP	Celsius/Fahrenheit	Select the temperature unit for the atmospheric correction.
PRESS	hPa/mmHg/inHg	Select the air pressure unit for the atmospheric correction .
ANGLE	deg / gon / mil	Select degree(360°), gon(400G) or mil (6400M) for the measuring angle unit to be shown on the display .
DIST	m/ft	Select the distance measuring unit Meter or Feet shown on the display.
FEET	US/ INTERNATIONAL	Select the meter / feet conversion factor. US survey feet 1m=3.2808333333333333 ft. International feet 1m=3.280839895013123 ft.

5.2 Setting Parameters

[Example setting] S/A BUZZER: OFF

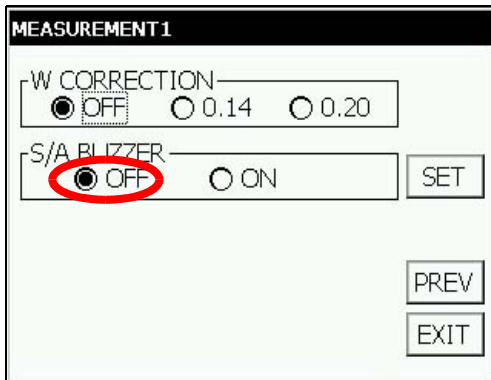
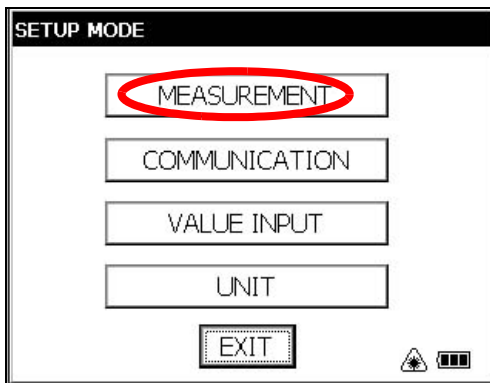
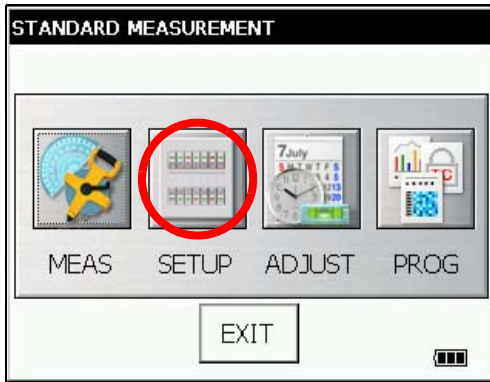

- 1 Press the [SETUP] icon.
- 2 Press the [MEASUREMENT] key.
- 3 Press the [MEASUREMENT1] key.
- 4 Press the [NEXT] key three times.
- 5 Select the [OFF] button of S/A BUZZER.*1)
- 6 When the [SET] key is pressed, the setting will be set and the SETUP MODE screen will reappear.

*1)To return to the SETUP MODE screen, press the [EXIT] key.

6 CHECK AND ADJUSTMENT

6.1 Checking and Adjusting of Instrument Constant

Note: Each of the Prism mode, Non-prism mode and Non-prism long mode has instrument constant. You must obtain the instrument constant of the prism mode.
If you change the instrument constant of the prism mode, be sure to change the instrument constant of the non-prism mode and the instrument constant of the non-prism long mode by the same amount.

Normally, the instrument constant does not have discrepancy. It is recommended you measure and compare with an accurately measured distance at a location where the precision is specifically monitored on a consistent basis. If such a location is not available, establish your own base line over 20m (when purchasing the instrument) and compare with the data measured with newly purchased instrument.

In both cases note that the setup displacement of the instrument position over the point, the prism, baseline precision, poor collimation, atmospheric correction, and correction for refraction and earth curvature determine the inspection precision. Please keep in mind these points.

Also, when providing a base line in a building, please note that the difference in temperature greatly changes the length measured in the building.

If the difference between the measured length of the baseline and the actual length exceeds the range of the nominal accuracy, change the instrument constant of the prism mode according to the following procedure.

- 1) On a basically horizontal line of about 100 meters, line AB, establish point C. Measure each distance, AB, AC and BC, about 10 times, and calculate the average value for each.

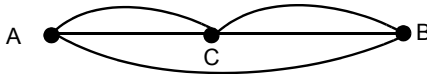

- 2) Repeat Step 1 several times. Then calculate the variance with the current instrument constant (ΔK).
$$\Delta K = AB - (AC + BC)$$
- 3) Calculate the new instrument constant according to the formula below. Then reset the instrument constant according to Section 6.4 "How to Set the Instrument Constant Value".
New instrument constant = current instrument constant + ΔK
- 4) Once again, measure the baseline and compare the results to the baseline's actual length. If the difference between the two is within the range of the nominal accuracy, change the instrument constant of the non-prism mode and the instrument constant of the non-prism long mode according to the formula in Step 3.
- 5) If the results of the measurement conducted in Step 4 exceed the range of the nominal accuracy, contact TOPCON or your TOPCON dealer.

6.1.1 Checking of the accuracy of the non-prism mode / non-prism long mode

If you reset the instrument constant, you must check the accuracy of the non-prism mode/non-prism long mode.

Non-prism mode

- 1) Set a prism 30 to 50 meter apart from the instrument and measure the distance to the prism by prism mode.
- 2) Take off the prism and set a (white) board.
- 3) Change the mode to the non-prism mode and measure the distance to the board.
- 4) Repeat above procedure and measure some points.
If the difference of the prism mode and non-prism mode is the range of $\pm 10\text{mm}$ even one time, the instrument is normal.
If the difference is never the range of $\pm 10\text{mm}$, contact TOPCON or your TOPCON dealer.

Non-prism long mode

- 1) Set a prism 30 to 50 meter apart from the instrument and measure the distance to the prism by prism mode.
- 2) Take off the prism and set a (white) board.
- 3) Change the mode to the non-prism long mode and measure the distance to the board.
- 4) Repeat above procedure and measure some points.
If the difference of the prism mode and non-prism long mode is the range of $\pm 20\text{mm}$ even one time, the instrument is normal.
If the difference is never the range of $\pm 20\text{mm}$, contact TOPCON or your TOPCON dealer.

6.2 Checking the Optical Axis

6.2.1 Checking the optical axis of EDM and theodolite

GTS-750

To check if the optical axis of EDM and theodolite are matched, follow the procedure below. It is especially important to check after adjustment of the eyepiece reticle is carried out.

- 1) Position the Instrument and prism with about 2m apart and face them at each other.
(At this time, the power is ON.)

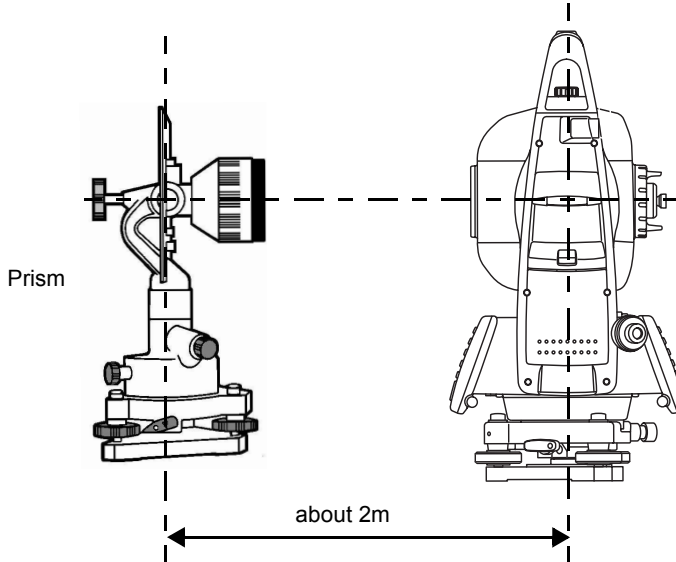

- 2) Sight through the eyepiece and focus to the prism. Then center the prism on the cross hairs.

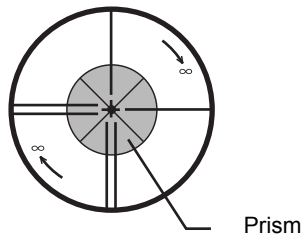

- 3) Set to the measure mode to distance measurement or set audio.
- 4) Sight through the eyepiece and focus the (blinking) red light spot by turning the focusing knob in the direction of infinity (clockwise). If displacement of the reticle cross hairs is within one-fifth of the diameter of the round red light spot both vertically and horizontally, adjustment will not be required.



If displacement is more than one-fifth in the above case, and still remains so after rechecking the original line of sight, the instrument must be adjusted by competent technicians. Please contact TOPCON or your TOPCON dealer to adjust the instrument.

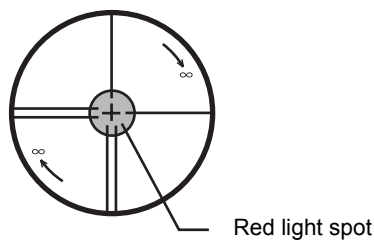

GPT-7500

Check each of the optical axis of EDM and theodolite about prism mode and non-prism mode in order. (In non-prism long mode: Check the same way in non-prism mode.)

To check if the optical axis of EDM and theodolite are matched, follow the procedure below.

It is especially important to check after adjustment of the eyepiece reticle is carried out.

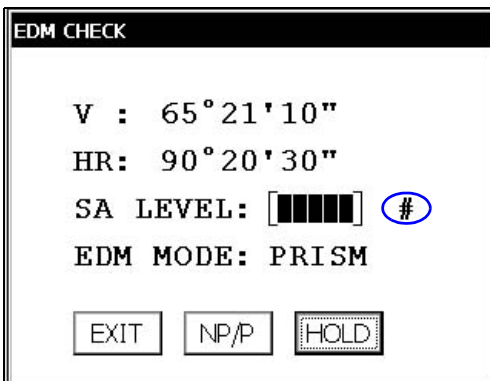
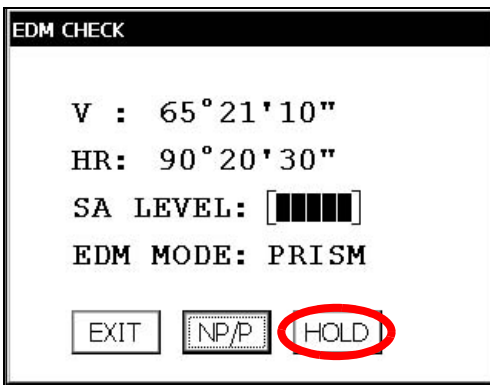
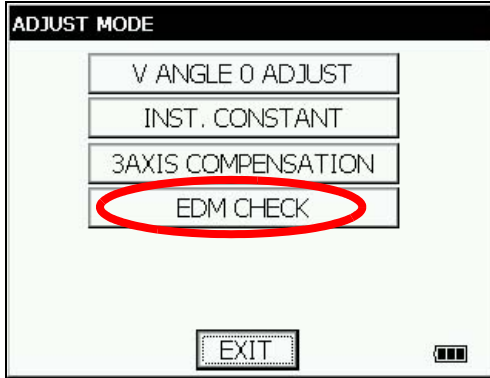
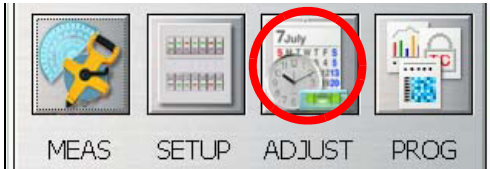

- 1 Position a prism about 50 to 100m apart from GPT-7500.
- 2 Press the [ADJUST] icon.
- 3 Press the [EDM CHECK] key.

In non-prism long mode:
The unit can not switch into EDM check mode.

In EDM check mode:
The unit can not switch into star key mode.
- 4 Collimate the center of a prism by prism mode.
The buzzer will sound.
- 5 Press the [HOLD] key to hold the quantity of the light.

The mark "#" will appear on the right side of the signal level indicator.

- **H direction confirmation (Do not move V direction).**

6 Turn the horizontal tangent screw, move the collimating point to the left side of prism gradually until buzzer sound stops.

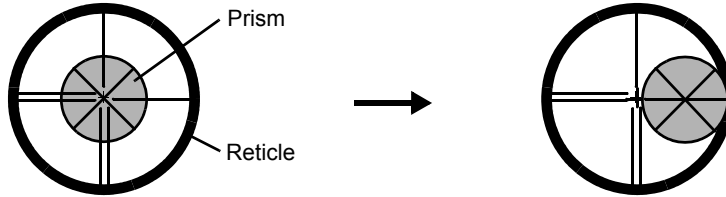

7 Turn the horizontal tangent screw slowly, and move the collimating point to the prism center gradually until at the position buzzer starts. Confirm the level of the signal (light quantity level) in display to adjust at the level of one to two as shown in below by turning the horizontal tangent screw.

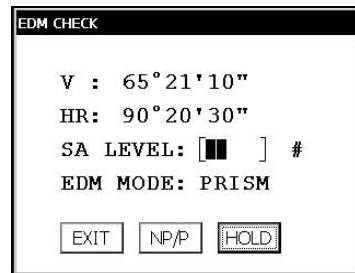
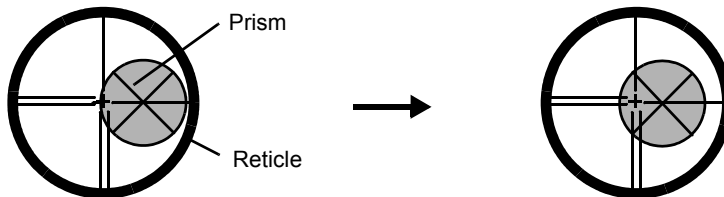

Quantity level two

8 Note the horizontal angle displayed.

9 Turn the horizontal tangent screw, move the collimating point to the right side of prism gradually until buzzer sound stops.

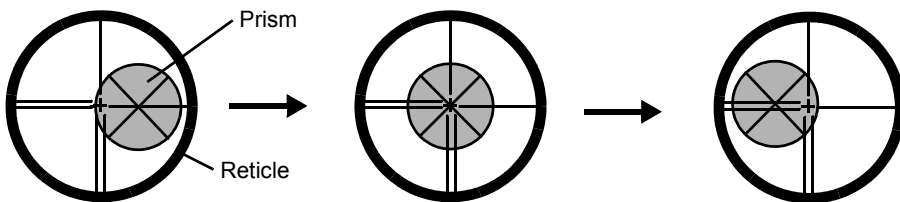

10 Move the collimating point to the center of prism gradually until buzzer sound starts. Turning the horizontal tangent screw to be one to two level of SIG value to adjust the collimating point same as step 7 procedure.

11 Note horizontal angle same as step 8 procedure.

6 CHECK AND ADJUSTMENT

12 Calculate the horizontal angle of center of the prism by step 8 and 11.

[Example]	Step 8 :	0°01'20"
	Step 11 :	0°09'40"
		Calculated value 0°05'30"

13 Collimate to the center of prism.

Compare the reading horizontal angle and calculated average value in step 12.

[Example] Horizontal angle of the center of the prism: 0°05'50"
 Difference of Average value and Horizontal reading of the center of the prism : 20"

If the difference is within 2', no problem for use.

- **Vertical direction confirmation (Do not move Horizontal direction).**

14 Carry out as Horizontal direction confirmation.

Compare the reading vertical angle of center of prism and calculated average value.
 If the difference is within 2', no problem for use.

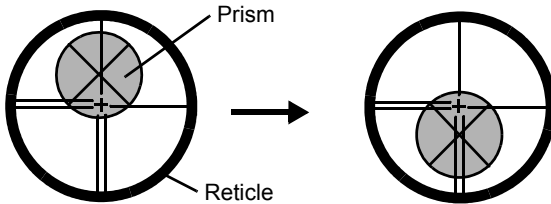

[Example]	Lower side of prism	90°12'30"
	Upper side of prism	90°04'30"
		Average 90°08'30"

Reading to prism center 90°08'50"

Difference 20"

If the difference is more than mentioned value, contact with your Topcon dealer or Topcon.

- **For non-prism mode**

If the instrument is in the hold mode, press the [HOLD] key to release the hold mode.

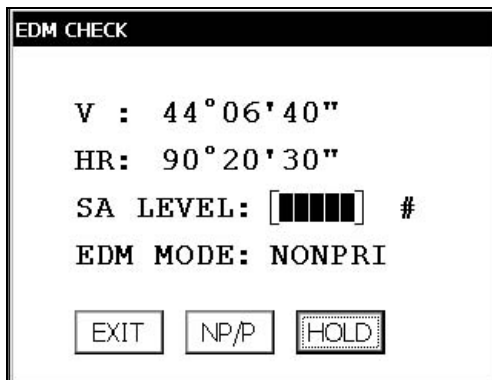
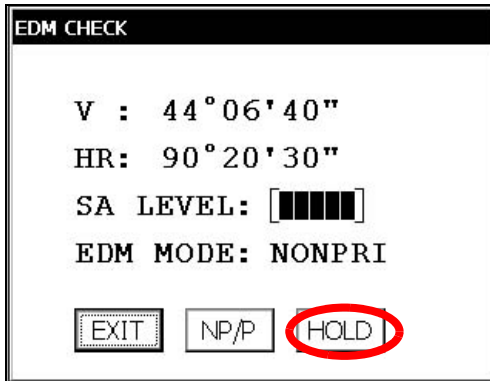

- 15** Press the [NP/P] key to change the non-prism mode.
- 16** Collimate the center of the prism.
- 17** Press the [HOLD] key to hold the quantity of the light.
The mark "#" will appear on the right side of the signal level indicator.

- 18** Repeat the previous procedure 6 to 14 in the same way in the non-prism mode.
If the difference is within 2', no problem for use.
If the difference is more than mentioned value, contact with your Topcon dealer or Topcon.

6.2.2 Checking the optical axis of Laser pointer

(Only for GPT-7500)

Check whether the optical axis of the laser pointer coincides with the optical axis of the telescope by carrying out the following steps.

The laser pointer indicates the approximate collimation position of the telescope. It does not indicate the exact collimation position. Therefore, it is not failure of the GPT-7500 although it may shift to 6mm by the optical axis and laser point on the target about 10 meters from the GPT-7500.

- 1) On the center of a piece of graph paper or white paper, draw a target in the form of a vertical line and an intersecting horizontal line.
- 2) Set up the target about 10 meters from the GPT-7500, and collimate the instrument to the point of intersection of the two lines.
- 3) Turn on power to the instrument, press the star key mode, and then press the L. P. key, lighting up the laser pointer.

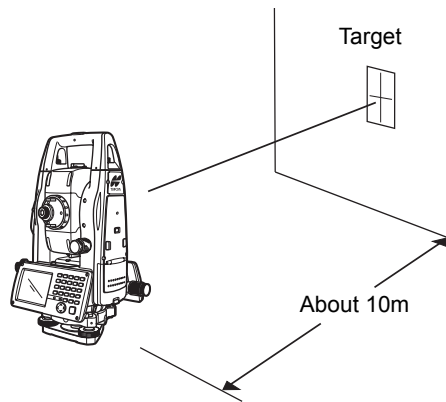

• Checking of laser pointer's optical axis

- 4) With the instrument collimated to the point of intersection of the two lines, check whether the center of the laser pointer is within about 6 mm of the point of intersection.

Note: If you look through the telescope at this time, you will not be able to see the laser pointer. Therefore, conduct this check with the naked eye, viewing the target and the laser pointer from the side of, or from above, the GPT-7500.

- 5) If the center of the laser pointer is within about 6 mm of the point of intersection, there will be no problems with using the instrument. If the distance is greater than 6 mm, carry out the following steps to align the center of the laser pointer with the point of intersection, and to align the laser pointer's optical axis with that of the telescope.

• Adjusting the laser pointer's optical axis

- 6) As shown in the drawing, remove the 3 rubber caps on top of the instrument, revealing the adjustment screws.
- 7) Using the accessory hexagonal wrench, adjust each of the screws - A, B and C - thereby moving the laser pointer so that it coincides with the point of intersection.

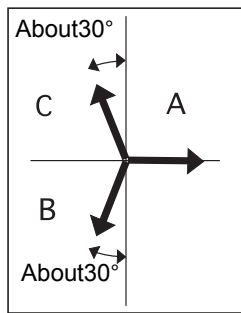

The direction of the laser pointer

As seen from above

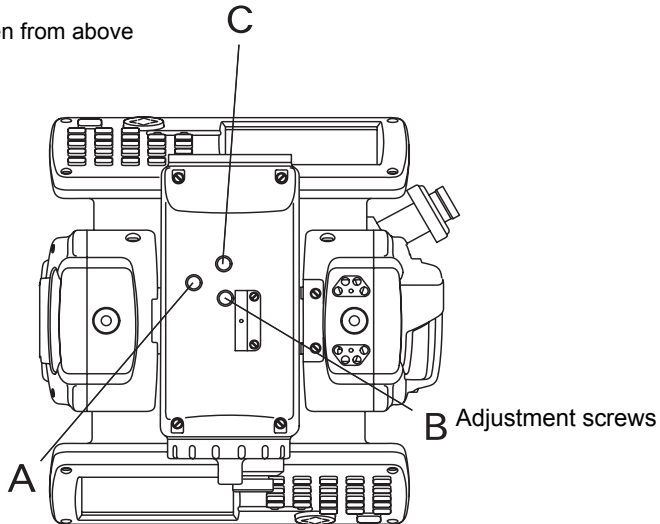

When screws A, B and C are turned clockwise (the direction for tightening them), the laser pointer, as seen on the target from the standpoint of the GPT-7500, will move in the direction shown in the drawing.

- Tighten the 3 screws so that they are equally tight.
- Do not lose the rubber caps of the adjustment screws.
- Place the operation keys on the telescope eyepiece side, and then turn on the laser pointer (The laser pointer will not be emitted if the operation keys are placed on the objective lens side).

6.3 Checking/Adjusting the Theodolite Functions

- **Pointers on the Adjustment**

- 1) Adjust the eyepiece of the telescope properly prior to any checking operation which involves sighting through the telescope.
Remember to focus properly, with parallax completely eliminated.
- 2) Carry out the adjustments in the order of item numbers, as the adjustments are dependent one upon another. Adjustments carried out in the wrong sequence may even nullify previous adjustment.
- 3) Always conclude adjustments by tightening the adjustment screws securely (but do not tighten them more than necessary, as you may strip the threads, twist off the screw or place undue stress on the parts).
Furthermore, always tighten by revolving in the direction of tightening tension.
- 4) The attachment screws must also be tightened sufficiently, upon completion of adjustments.
- 5) Always repeat checking operations after adjustments are made, in order to confirm results.

- **Notes on the Tribrach**

Note that the angle measuring precision may be effected directly if the tribrach has not been installed firmly.

- 1) If any leveling screw becomes loose and slack or if collimation is unstable due to the looseness of leveling screws, adjust by tightening the adjusting screws (in 2 places) installed over each leveling screw with a screwdriver
- 2) If there is any slack between the leveling screws and the base, loosen the set screw of the holding ring and tighten the holding ring with adjusting pin, until it is properly adjusted. Re-tighten the set screw on completing the adjustment.

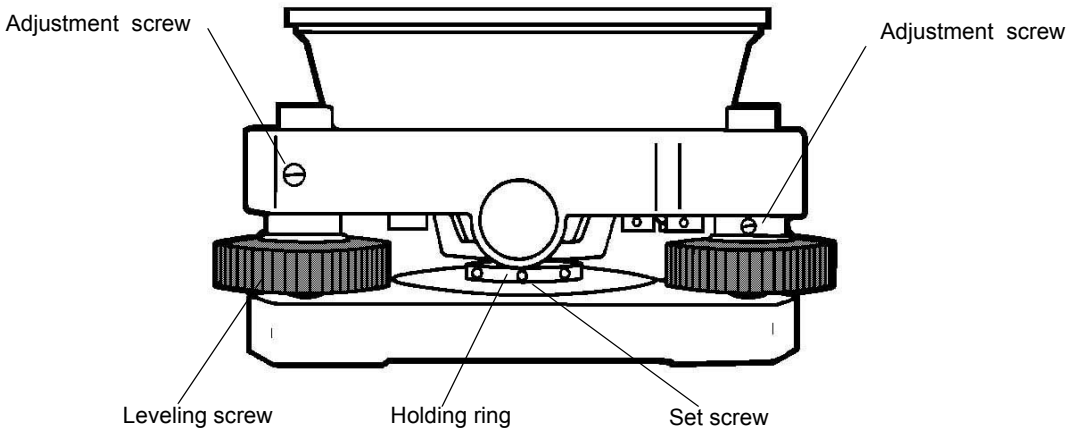

6.3.1 Checking /Adjusting the Plate Level

Adjustment is required if the axis of the plate level is not perpendicular to the vertical axis.

- **Check**

- 1) Place the plate level parallel to a line running through the centers of two leveling screws, say, A and B. Use these two leveling screws only and place the bubble in the center of the plate level.
- 2) Rotate the instrument 180° or $200g$ around the vertical axis and check bubble movement of the plate level. If the bubble has been displaced, then proceed with the following adjustment.

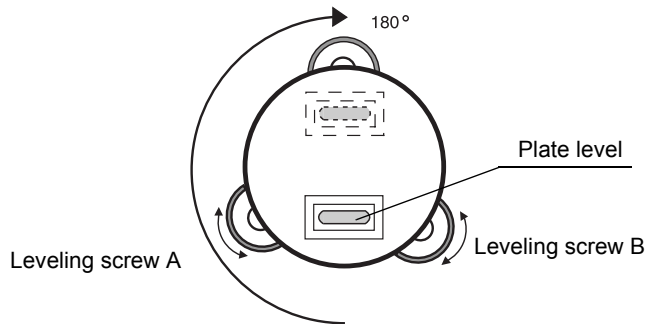

- **Adjustment**

- 1) Adjust the level adjustment capstan screw, with the accessory adjusting pin and return the bubble towards the center of the plate level. Correct only one-half of the displacement by this method.
- 2) Correct the remaining amount of the bubble displacement with the leveling screws.
- 3) Rotate the instrument 180° or $200g$ around the vertical axis once more and check bubble movement. If the bubble is still displaced, then repeat the adjustment.

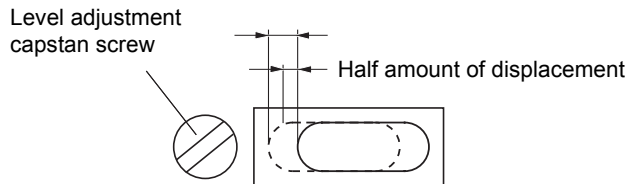

6.3.2 Checking /Adjusting the Circular Level

Adjustment is required if the axis of the circular level is also not perpendicular to the vertical axis.

- **Check**

- 1) Carefully level the instrument with the plate level only. If the bubble of the circular level is centered properly, adjustment is not required. Otherwise, proceed with the following adjustment.

- **Adjustment**

- 1) Shift the bubble to the center of the circular level, by adjusting three capstan adjustment screws on the bottom surface of the circular level, with the accessory adjusting pin.

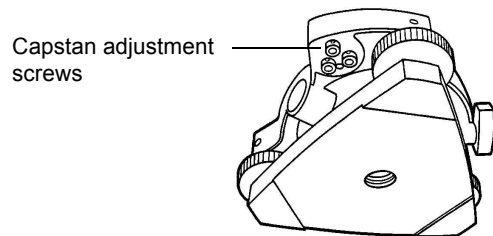
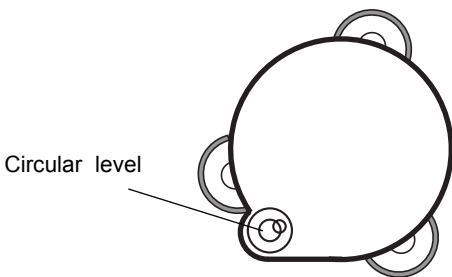

6.3.3 Adjustment of the Vertical Cross-hair

Adjustment is required if the vertical cross-hair is not in a plane perpendicular to the horizontal axis of the telescope (since it must be possible to use any point on the hair for measuring horizontal angles or running lines).

• **Check**

- 1) Set the instrument up the tripod and carefully level it.
- 2) Sight the cross-hairs on a well defined Point A at a distance of, at least, 50 meters (160ft.) and clamp horizontal motion.
- 3) Next swing the telescope vertically using the vertical jog/shuttle, and check whether the point travels along the length of the vertical cross-hair.
- 4) If the point appears to move continuously on the hair, the vertical cross-hair lies in a plane perpendicular to the horizontal axis (and adjustment is not required).
- 5) However, if the point appears to be displaced from the vertical cross-hair, as the telescope is swung vertically, then proceed with the following adjustment.

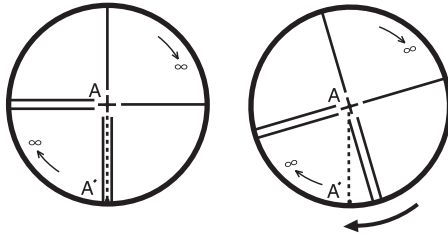

• **Adjustment**

- 1) Unscrew the cross-hair adjustment section cover, by revolving it in the counterclockwise direction, and take it off. This will expose four eyepiece section attachment screws.

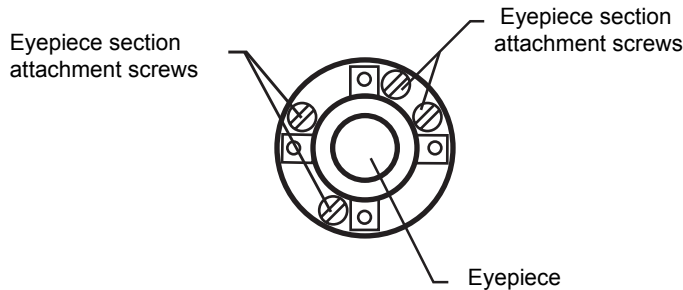

- 2) Loosen all four attachment screws slightly with the accessory screw-drive (while taking note of the number of revolutions).
Then revolve the eyepiece section so that the vertical cross-hair coincides to Point A'.
Finally, re-tighten the four screws by the amount that they were loosened.
- 3) Check once more and if the point travels the entire length of the vertical cross-hair, further adjustment is not required.

Perform following adjustment after completing the above adjustment.
 Section 6.3.4 "Collimation of the Instrument",
 Section 6.3.6 "Adjustment of Vertical Angle 0 Datum"
 Section 6.2 "Checking the Optical Axis"

6.3.4 Collimation of the Instrument

Collimation is required to make the line of sight of the telescope perpendicular to the horizontal axis of the instrument, otherwise, it will not be possible to extend a straight line by direct means.

• Check

- 1) Set the instrument up with clear sights of about 50 to 60 meters (160 to 200 ft.) on both sides of the instrument.
- 2) Level the instrument properly with the plate level.
- 3) Sight Point A at approximately 50 meters (160 ft.) distance.
- 4) Loosen the vertical motion clamp only, and rotate the telescope 180° or $200g$ around the horizontal axis, so that the telescope is pointed in the opposite direction.
- 5) Sight Point B, at equal distance as Point A and tighten the vertical motion clamp.
- 6) Loosen the horizontal motion clamp and rotate the instrument 180° or $200g$ around the vertical axis. Fix a sight on Point A once more and tighten the horizontal motion clamp.
- 7) Loosen the vertical motion clamp only and rotate the telescope 180° or $200g$ around the horizontal axis once more and fix a sight on Point C, which should coincide with previous Point B.
- 8) If Points B and C do not coincide, adjust in the following manner.

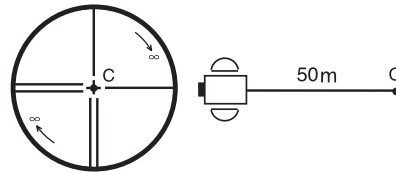
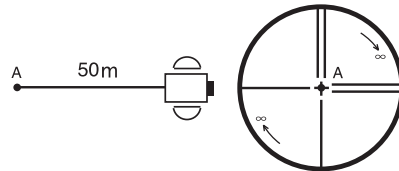
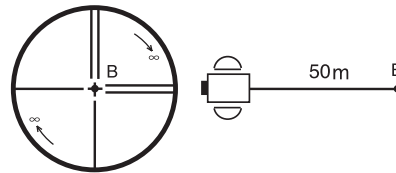
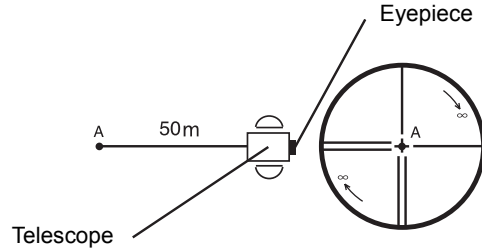

• Adjustment

- 1) Unscrew the cross-hair adjustment section cover.
- 2) Find Point D at a point between Points C and B, which should be equal to $1/4$ th the distance between Points B and C and measured from Point C. This is because the apparent error between Points B and C is four times the actual error since the telescope has been reversed twice during the checking operation.
- 3) Shift the vertical cross-hair line and coincide it with Point D, by revolving the left and right capstan adjustment screws with the adjusting pin. Upon completing the adjustment, repeat the checking operation once more. If Points B and C coincide, further adjustment is not required. Otherwise, repeat the adjustment.

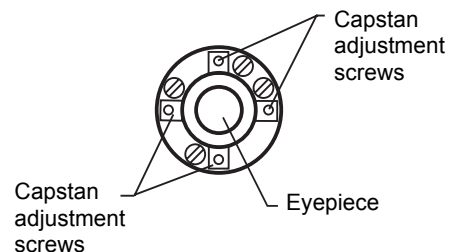
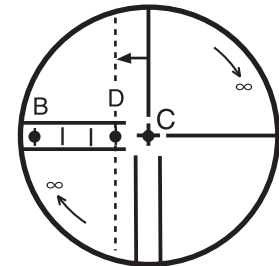



First, loosen the capstan adjustment screw on the side to which the vertical cross-hair line must be moved. Then tighten the adjustment screw on the opposite side by an equal amount which will leave the tension of the adjustment screws unchanged. Revolve in the counterclockwise direction to loosen and in the clockwise direction to tighten, but revolve as little as possible.

Perform following adjustment after complete above adjustment.
 Section 6.5 "Compensation Systematic Error of Instrument".
 Section 6.2 "Checking the Optical Axis".

6.3.5 Checking / Adjusting the Optical Plummet Telescope

Adjustment is required to make the line of sight of the optical plummet telescope coincide with the vertical axis (otherwise the vertical axis will not be in the true vertical when the instrument is optically plumbed).

• **Check**

- 1) Coincide the center mark and the point. (See Chapter 2 "PREPARATION FOR MEASUREMENT".)
- 2) Rotate the instrument 180° or 200g around the vertical axis and check the center mark.
 If the point is properly centered in the center mark, adjustment is not required. Otherwise, adjust in the following manner.

• **Adjustment**

- 1) Take off the adjustment section cover of the optical plummet telescope eyepiece. This will expose four capstan adjustment screws which should be adjusted with the accessory adjusting pin to shift the center mark to the point. However, correct only one-half of the displacement in this manner.

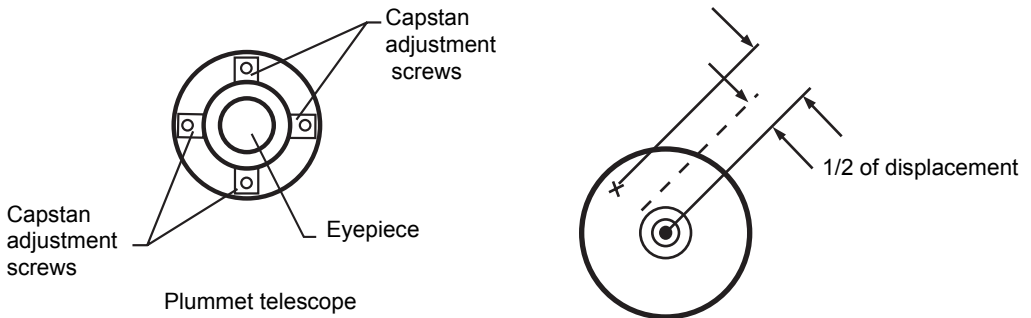

- 2) Use the leveling screws and coincide the point and center mark.
- 3) Rotate the instrument 180° or 200g around the vertical axis once more and check the center mark. If it is coincided to the point, then further adjustment is not required. Otherwise, repeat the adjustment.



First, loosen the capstan adjustment screw on the side to which the center mark must be moved. Then tighten the adjustment screw on the opposite side by an equal amount which will leave the tension of the adjustment screws unchanged. Revolve in the counterclockwise direction to loosen and in the clockwise direction to tighten, but revolve as little as possible.

6.3.6 Adjustment of Vertical Angle 0 Datum

If when measuring the vertical angle of target A at telescope position normal (direct) and reverse settings, the amount of normal and reverse measurements combined is other than 360° (ZENITH-0), half of the difference from 360° is the error amount from corrected 0 setting. Carry out adjustment. As adjustment for vertical angle 0 setting is the criteria for determining instrument coordinate origin, use special care for adjustment.

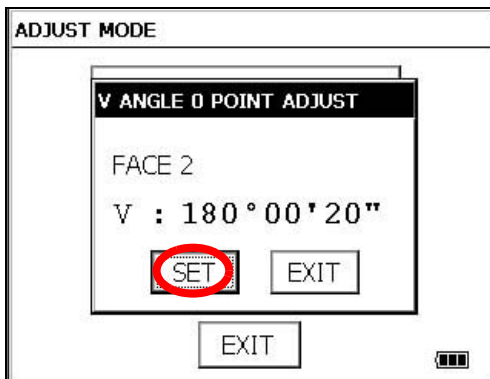
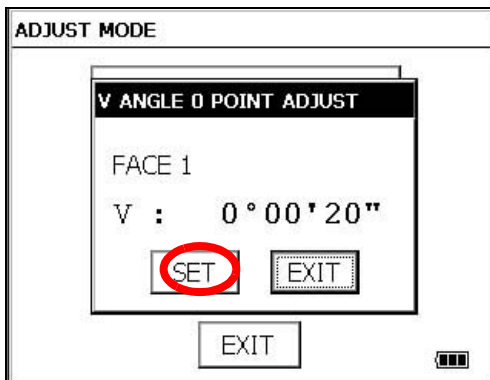

- 1 Level the instrument properly with the plate level.
- 2 Press the [ADJUST] icon.
- 3 Press the [V ANGLE 0 ADJUST] key.
- 4 Collimate target A from the telescope properly in normal setting.
- 5 Press the [SET] key.
- 6 Collimate target A in reverse telescope setting.
- 7 Press the [SET] key. Measured value is set and carry out adjustment mode.
- 8 Check that the total amount of normal and reverse angular travel is 360° collimating the target A by normal and reverse positions.

6.4 How to Set the Instrument Constant Value

To set the Instrument constant which is obtained in section 6.1“Checking and Adjusting of Instrument Constant” , follow as below.

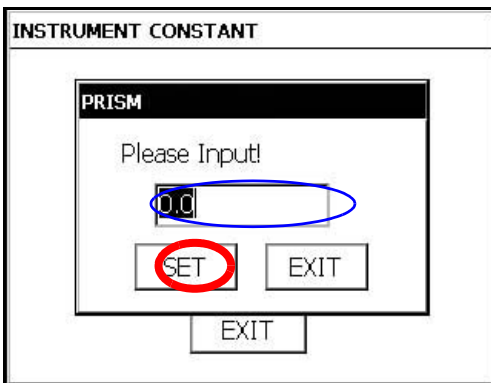

1 Press the [ADJUST] icon from the main menu.

2 Press the [INST. CONSTANT] key.

3 Press the [PRISM] key.

4 Input value. * 1)

5 Press the [SET] key.

The display returns to previous menu.

*1) To cancel the setting, press the [EXIT] key.

6.5 Compensation Systematic Error of Instrument

6.5.1 Adjustment of Compensation Systematic Error of Instrument

- 1) Error of vertical axis (X,Y tilt sensor offset)
- 2) Collimation error
- 3) Error of vertical angle 0 datum
- 4) Error of horizontal axis

The above mentioned errors will be compensated by software, which calculated internally according to each compensation value.

Also these errors can be compensated by software collimating one side of the telescope that is carried out to delete the error by turning in normal and reverse both sides of telescope so far.

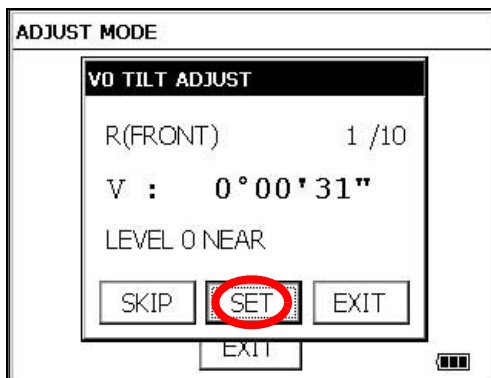
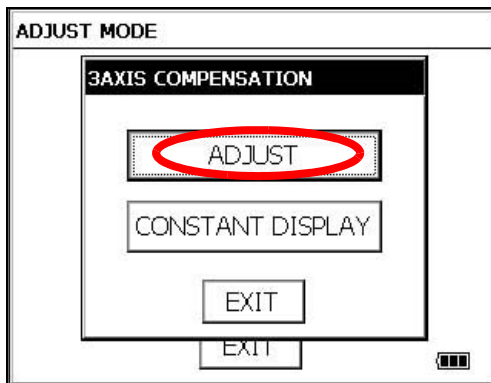
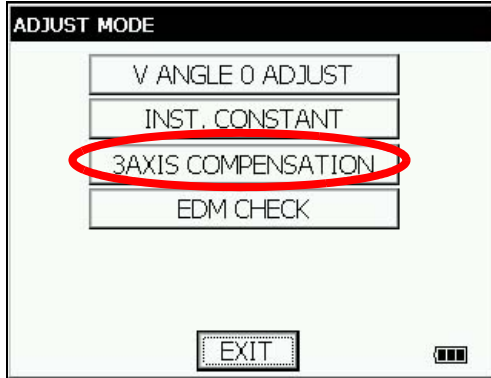

- 1 Level the instrument properly with the plate level.
- 2 Press the [ADJUST] icon from the main menu.
- 3 Press the [3AXIS COMPENSATION] key.

- 4 Press the [ADJUST] key.

- 5 Collimate target A (around 0° in horizontal within $\pm 3^\circ$) in normal telescope setting.

- 6 Press the [SET] key ten times.

The number of measurements is displayed at the top right of the display. *1)

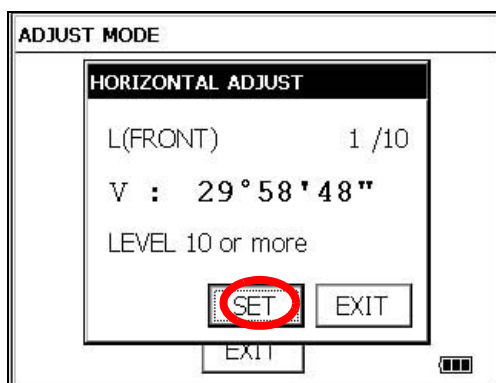
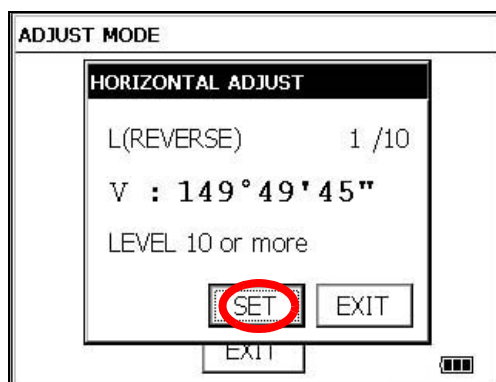
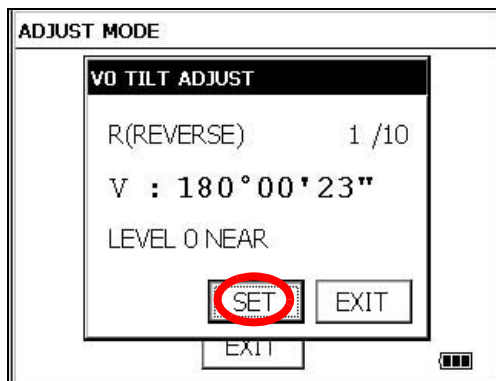

- 7 Turn the telescope in reverse telescope setting.
- 8 Collimate target A.
- 9 Press the [SET] key ten times.

The number of measurements is displayed at the top right of the display.

- 10 Collimate target B (more than $\pm 10^\circ$ from the level) in reverse telescope setting.
- 11 Press the [SET] key ten times.
The number of measurements is displayed at the top right of the display. *1)
- 12 Turn the telescope in normal telescope setting.
- 13 Collimate target B.

- 14 Press the [SET] key ten times.

Then the display returns to 3AXIS compensation menu.

*1) Pressing the [SKIP] key enables to set next step without changing the last compensated value.

6.5.2 Showing Compensation Systematic Error of Instrument

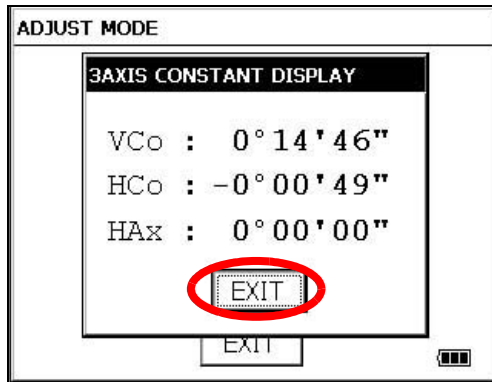
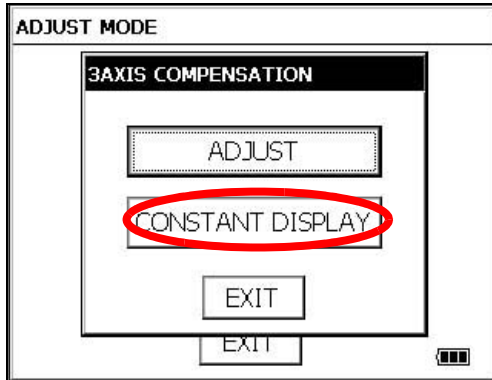

- 1 Press the [ADJUST] icon from the main menu.
- 2 Press the [3AXIS COMPENSATION] key.
- 3 Press the [CONSTANT DISPLAY] key.
- 4 Press the [EXIT] key.
The display returns to previous menu.

7 SETTING THE PRISM / NON-PRISM CONSTANT VALUE

The prism constant value of Topcon is set to zero. When using prisms other than Topcon's, it is necessary to set the prism constant correction value of that specific prism. Once you set the correction value for prism constant, it is retained after power is OFF.

Note: Confirm the non-prism constant value is set at 0 when measuring target such as walls in Non-prism mode/Non-prism long mode.

[Example]

• **How to Set Prism Constant Value**

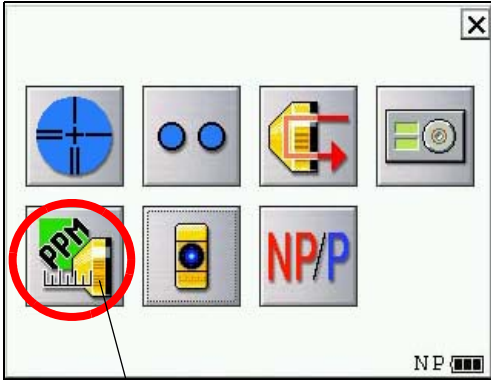

[Prism constant value, Atmospheric correction] icon

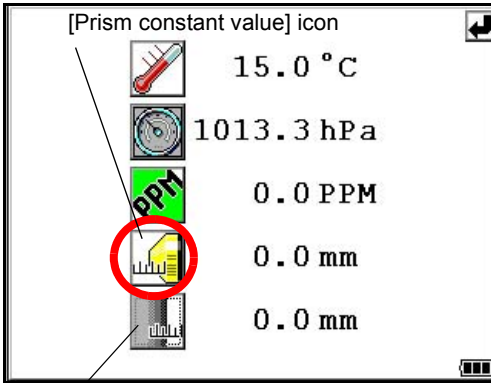

[Non-Prism constant value] icon

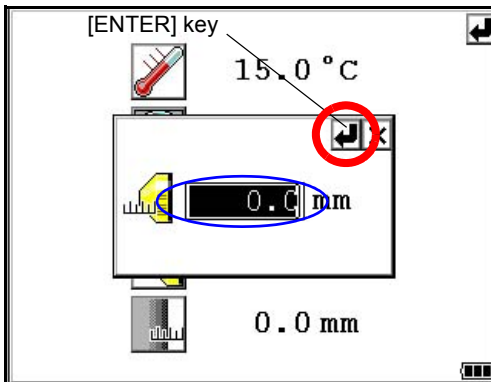

- 1 Turn the power switch on.
- 2 Press the [★] key.
- 3 Press the [Prism constant value, Atmospheric correction] icon.
- 4 Press the [Prism constant value] icon.
- 5 Input Prism constant value. *1)
[Example] 0.0mm
- 6 Press the [ENTER] key.

*1) Input range : -99.9mm ~ +99.9mm (0.1mm step)

8 SETTING ATMOSPHERIC CORRECTION

The velocity of light through air is not constant and depends on the atmospheric temperature and pressure. The atmospheric correction system of this instrument corrects automatically when the correction value is set. 15°C/59°F, and 1013.25hPa / 760mmHg / 29.9 inHg is as a standard value for ppm in this instrument. The values are kept in the memory even after power is OFF.

8.1 Calculation of Atmospheric Correction

GTS-750

The followings are the correction formulas. Unit; meter

$$Ka = \left\{ 279.67 - \frac{79.535 \times P}{273.15 + t} \right\} \times 10^{-6}$$

Ka: Atmospheric correction value
P : Ambient atmospheric pressure (hPa)
t : Ambient Atmospheric temperature (°C)

The distance L (m) after atmospheric correction is obtained as follow.

$$L = l / (1 + Ka)$$

l : Measured distance when atmospheric correction is not set.

Example : In case Temperature +20°C, Air pressure 847hPa, *l* = 1000 m

$$Ka = \left\{ 279.67 - \frac{79.535 \times 847}{273.15 + 20} \right\} \times 10^{-6}$$

$$\cong + 50 \times 10^{-6} \text{ (50 ppm)}$$

$$L = 1000 (1 + 50 \times 10^{-6}) = 1000.050 \text{ m}$$

GPT-7500

The followings are the correction formulas. Unit; meter

$$Ka = \left\{ 279.85 - \frac{79.585 \times P}{273.15 + t} \right\} \times 10^{-6}$$

Ka: Atmospheric correction value
P : Ambient atmospheric pressure (hPa)
t : Ambient Atmospheric temperature (°C)

The distance L (m) after atmospheric correction is obtained as follow.

$$L = l / (1 + Ka)$$

l : Measured distance when atmospheric correction is not set.

Example : In case Temperature +20°C, Air pressure 847hPa, *l* = 1000 m

$$Ka = \left\{ 279.85 - \frac{79.585 \times 847}{273.15 + 20} \right\} \times 10^{-6}$$

$$\cong + 50 \times 10^{-6} \text{ (50 ppm)}$$

$$L = 1000 (1 + 50 \times 10^{-6}) = 1000.050 \text{ m}$$

8.2 Setting of Atmospheric Correction Value

- **How to Set Temperature and Pressure Value Directly**

Measure the temperature and air pressure surrounding the instrument beforehand.

- Example : Temperature: +15°C, Pressure:1013.3 hPa

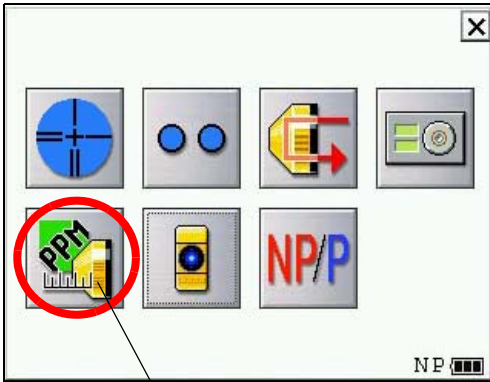

[Prism constant value, Atmospheric correction] icon

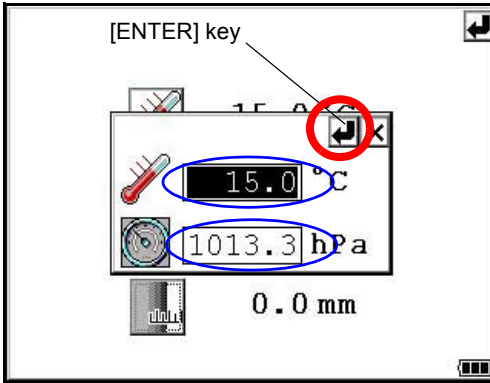
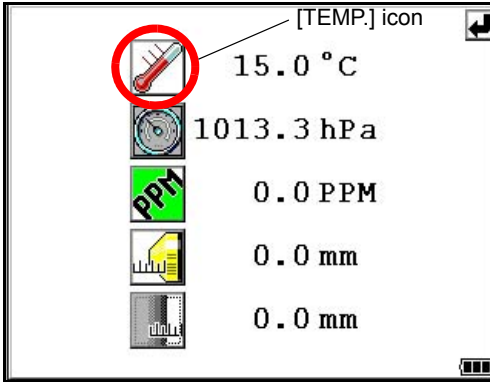

- 1 Turn the power switch on.
- 2 Press the [★] key.
- 3 Press the [Prism constant value, Atmospheric correction] icon.

- 4 Press the [TEMP.] icon.

- 5 Input Temp. value and Press. value.

[Example] *1) Temp. : +15.0°C
Press. : 1013.3hPa.

- 6 Press the [ENTER] key.

*1) Range :

Temp.

-30.0 °C to +60.0 °C (0.1 °C step) ,

-22.0 °F to +140.0 °F (0.1 °F step)

Press.

560.0 to 1066.0hPa (0.1hPa step) ,

420.0 to 800.0mmHg (0.1mmHg step) ,

16.5 to 31.5inHg (0.1inHg step)

• **How to Set the Atmospheric Correction Value Directly**

Measure the temperature and air pressure to find atmospheric correction value(PPM) from the chart or correction formula.

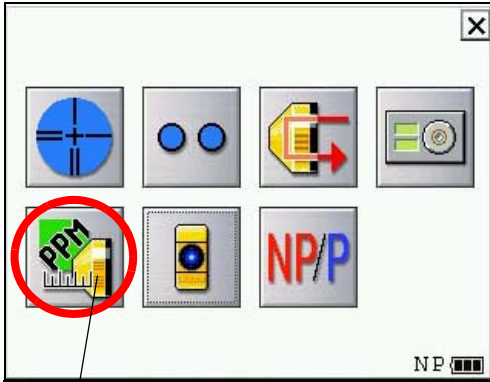

[Prism constant value, Atmospheric correction] icon

[PPM] icon

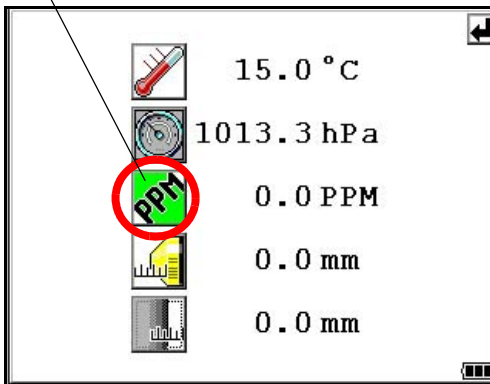

- 1 Turn the power switch on.
- 2 Press the [★] key.
- 3 Press the [Prism constant value, Atmospheric correction] icon.
- 4 Press the [PPM] icon.
- 5 Input atmospheric correction value. *1)
- 6 Press the [ENTER] key.

*1) Input range : -999.9mm ~ +999.9mm (0.1mm step)

8 SETTING ATMOSPHERIC CORRECTION

Atmospheric Correction Chart (For your reference)

The atmospheric correction value is obtained easily with the atmospheric correction chart. Find the measured temperature in horizontal, and pressure in vertical on the chart.

Read the value from the diagonal line, which represents the required atmospheric correction value.

Example:

The measured temperature is +26°C

The measured pressure is 1014 hPa

There fore,

The correction value is +10ppm

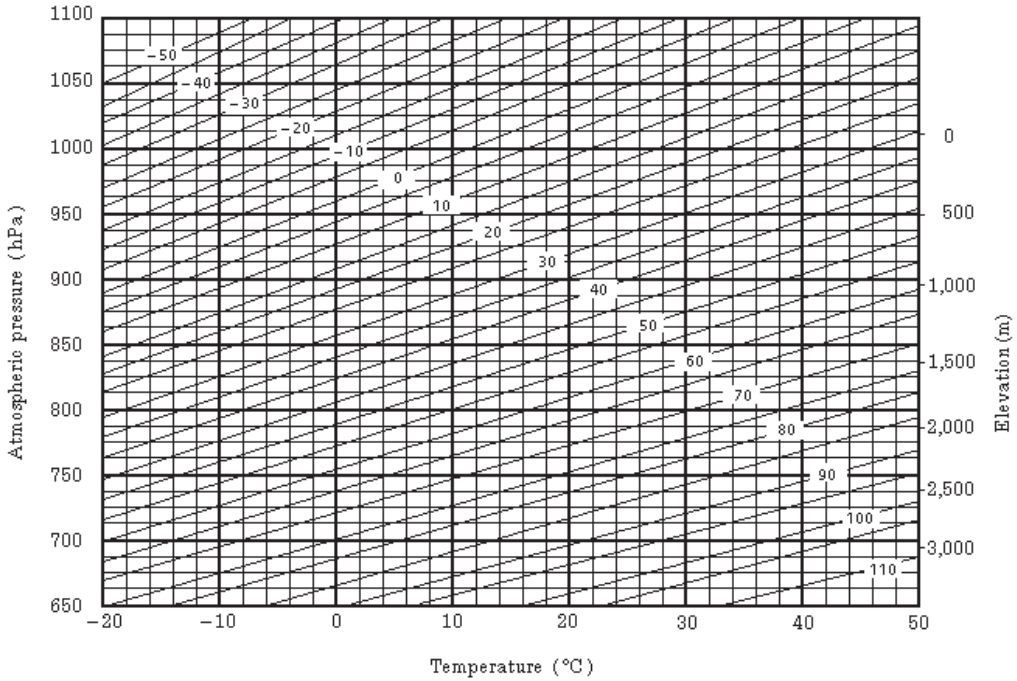

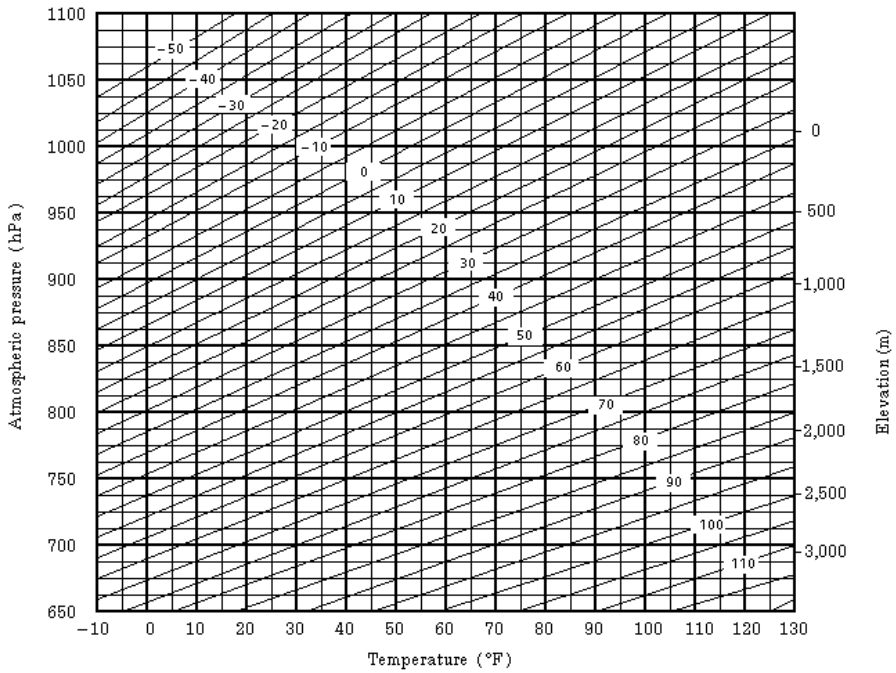
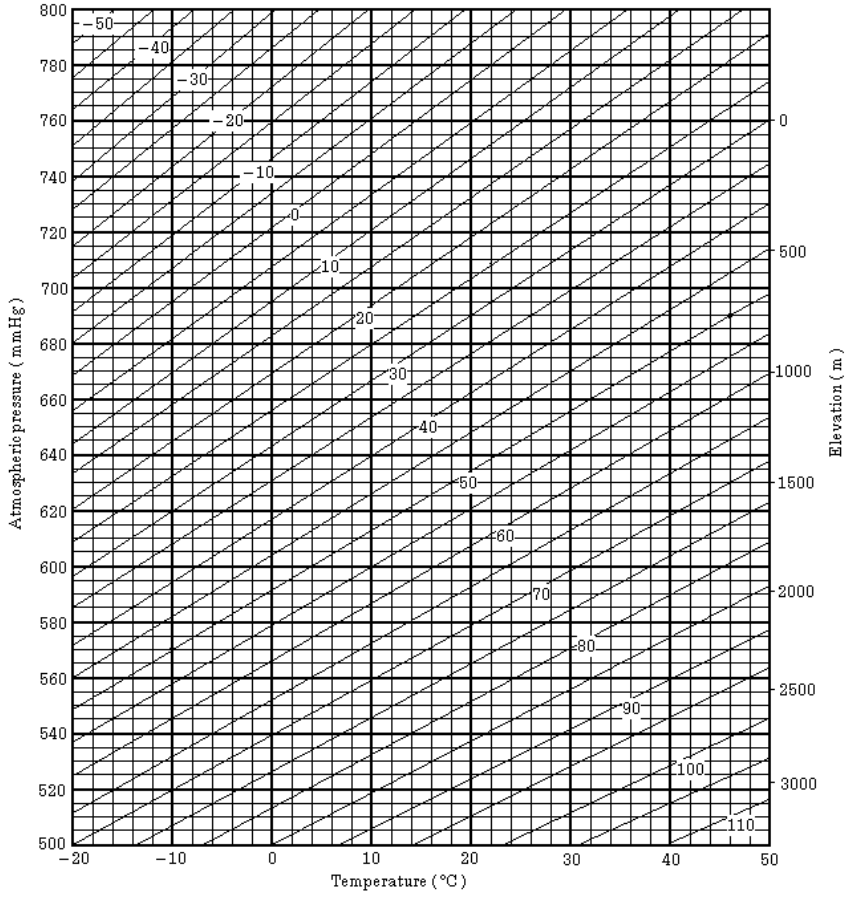

8 SETTING ATMOSPHERIC CORRECTION

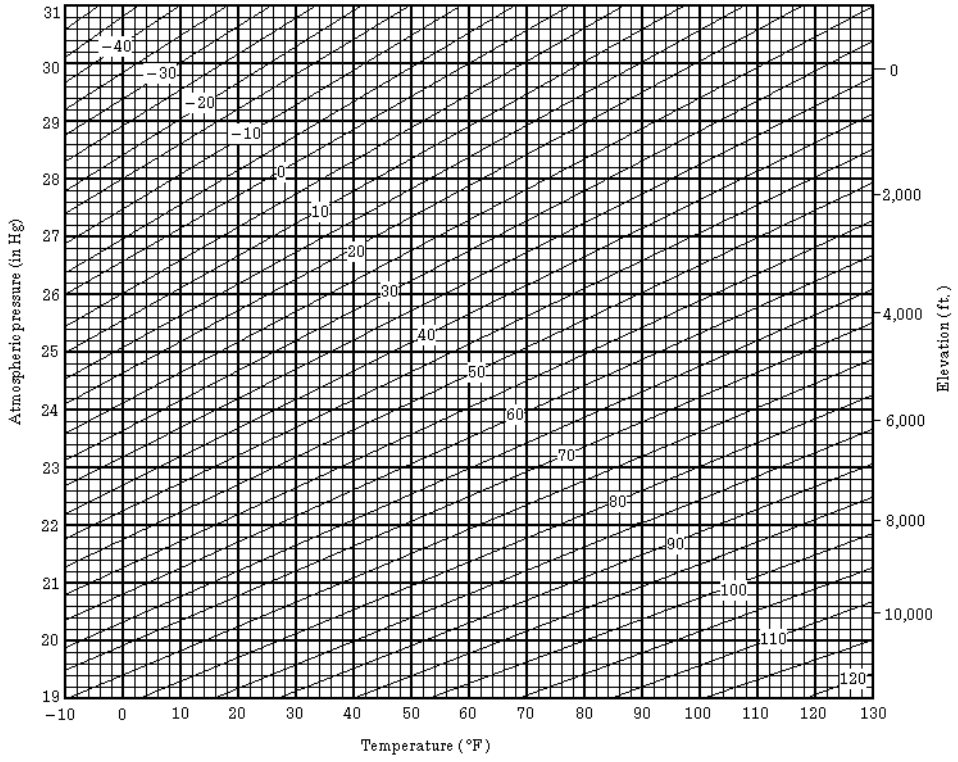

9 CORRECTION FOR REFRACTION AND EARTH CURVATURE

The instrument measures distance, taking into account correction for refraction and earth curvature.

9.1 Distance Calculation Formula

Distance Calculation Formula; with correction for refraction and earth curvature taken into account. Follow the Formula below for converting horizontal and vertical distances.

- Horizontal distance $D = AC(\alpha)$ or $BE(\beta)$
- Vertical distance $Z = BC(\alpha)$ or $EA(\beta)$
- $D = L\{\cos\alpha - (2\theta - \gamma) \sin\alpha\}$
- $Z = L\{\sin\alpha + (\theta - \gamma) \cos\alpha\}$
- $\theta = L \cdot \cos\alpha / 2R$ Earth curvature correcting item
- $\gamma = K \cdot L \cos\alpha / 2R$ Atmospheric refraction correcting item
- $K = 0.14$ or 0.2 Coefficient of refraction
- $R = 6372\text{km}$ Radius of earth
- α (or β)..... Altitude angle
- L Slope distance

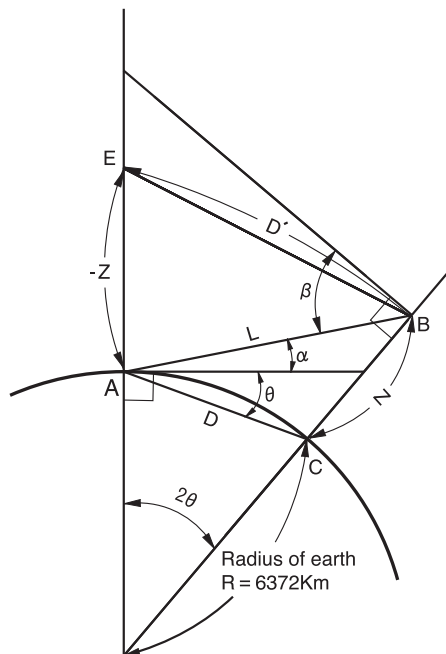

- The conversion formula for horizontal and vertical distances is as follows when correction for refraction and earth curvature is not applied.
 $D = L \cdot \cos\alpha$
 $Z = L \cdot \sin\alpha$

 The coefficient of the instrument has been set at 0.14 before shipment (K=0.14). if the "K" value is to be changed, refer to 5 "PARAMETERS SETTING MODE".

10 POWER SOURCE AND CHARGING

10.1 On-board Battery BT-65Q

- **To remove**

- 1 Pull the battery cover lever and open the cover.
- 2 Remove the battery.

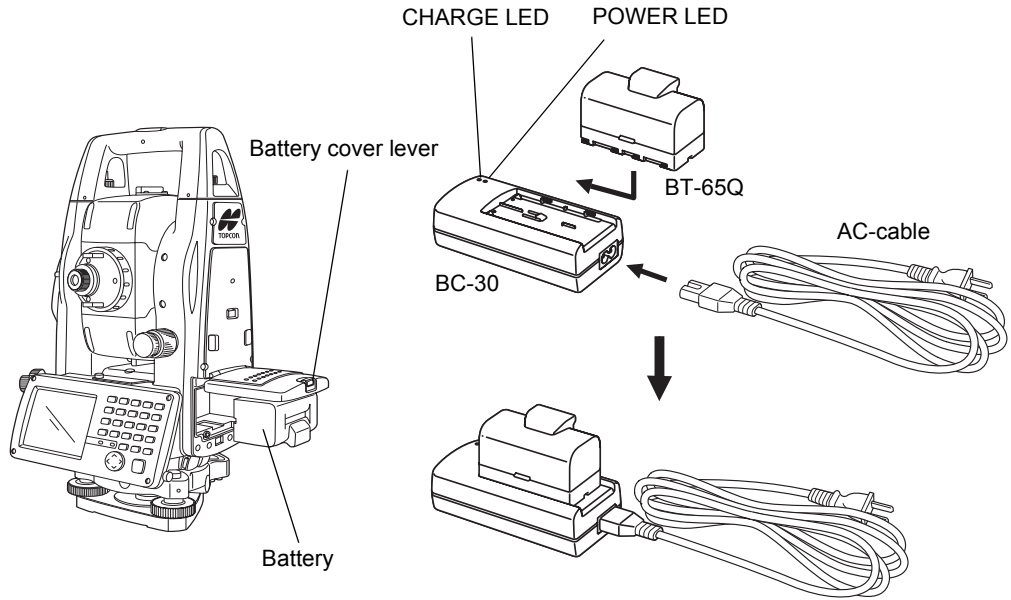

- **To charge**

- 1 Connect the AC-Cable to the charger.
- 2 Plug the AC-Plug into the outlet. (The POWER LED will light.)
- 3 Attach the battery in the charger. Charging will start. (The CHARGE LED will light.)
Charging will take approximately 5 hours. (The CHARGE LED will go out.)
If battery power is at a very low level when beginning charging, such as after the instrument has been in storage over an extended period of time in a discharge state, a full charge may not be possible with a single charging. In such a case, recharge a second time.
- 4 After charging, remove the battery from the charger.
Remove the charger from the outlet.

The POWER LED

Red ON : Power is on.

The CHARGE LED will indicate charging status;

On Solid : Wait for charging.
 Red ON : Charging.
 On Solid : Charging completed.
 Red Flashing: Charging error.

CHARGE LED will flash when the battery life is over or the battery is broken down. Replace the battery to new one.

- **To install**

- 1 Place the battery to the instrument.
- 2 Shut the battery cover until click sound can be heard.

- Do not charge or discharge continuously, otherwise the battery and the charger may be deteriorated.
If charging is necessary, use the charger after stopping charge for approximately 30 minutes.
- Do not charge the battery or discharge the battery in right after the battery is charged, it causes deterioration of the battery in rare cases.
- The charger may develop heat while charging, there is no problem of it.



- Note:
- 1 Recharging should take place in a room with an ambient temperature range of 10°C to 40°C (50°F to 104°F).
 - 2 If charging is done at high temperature, charging time of the battery may take longer.
 - 3 Exceeding the specified charging time may shorten the life of the battery and should be avoided if possible.
 - 4 The battery source will discharge when stored and should be checked before using with instrument.
 - 5 If the instrument is not used over an extended period of time, store in a place at 30°C or below in a 50% charged state.
Over discharge will lower performance and a full charge may become impossible.
Please charge once every few months.

11 DETACH/ATTACH OF TRIBRACH

The instrument is easily detached or attached to the tribrach.

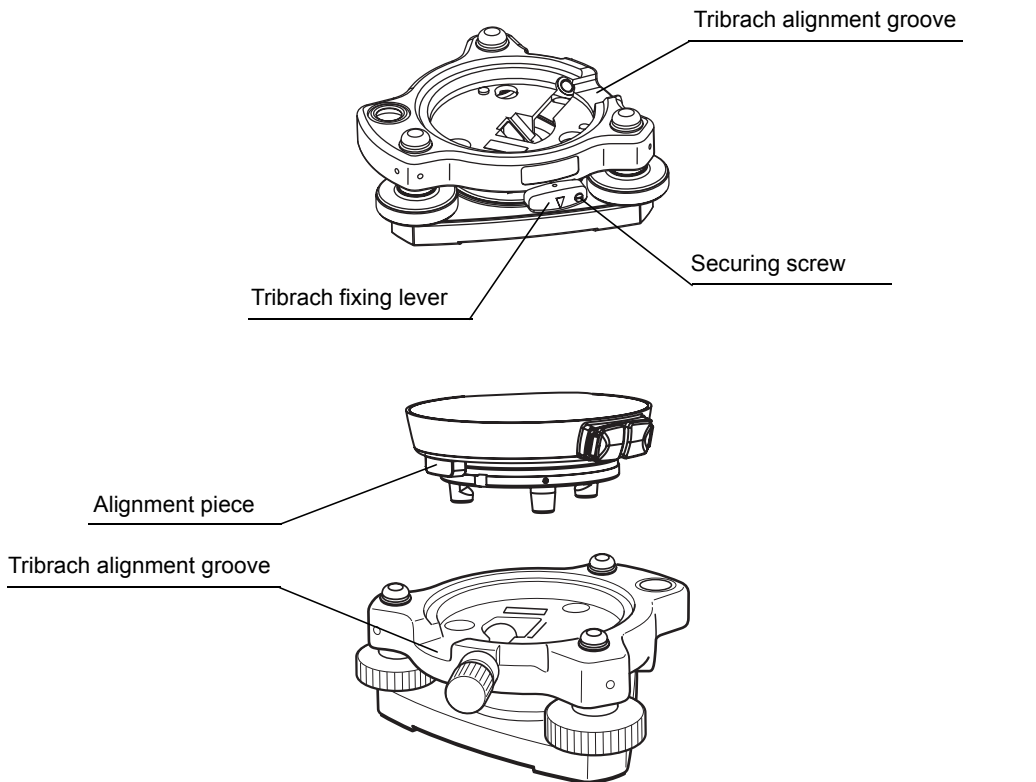

- **Detachment**

- 1) Loosen the tribrach fixing lever by turning counterclockwise.
- 2) Lift the instrument straight upwards and off.

- **Attachment**

- 1) Coincide the white alignment piece on the lower part of the instrument with the tribrach alignment groove.
- 2) Tighten the tribrach fixing lever firmly by turning clockwise.

- **Locking the Tribrach Fixing lever**

The tribrach fixing lever can be locked from being moved accidentally. This is useful if the upper instrument section is not being detached very often. Simply tighten the securing screw on the fixing lever with the accessory screw driver.

12 SPECIAL ACCESSORIES

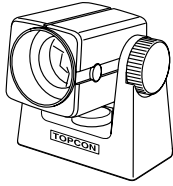

Mini prism

The mini prism (25.4mm) is made from precision ground glass and mounted in high impact plastic housings.

The mini has the unique capability of being positioned either at a "0" or "-30" with the same prism.

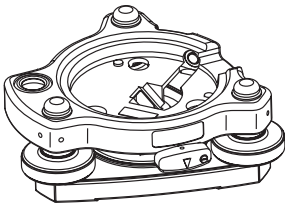

Tribrach TR-2

This is detachable tribrach having tribrach fixing screw.

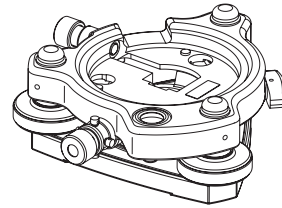

Optical plummet tribrach TR-2P

This is detachable tribrach having built-in optical plummet telescope.

(Compatible with Wild)

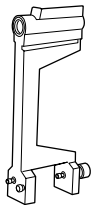

Trough compass, Model 6

Shock proof construction. No clamp is necessary when carrying the instrument.

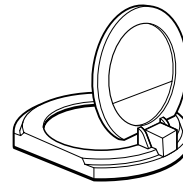

Solar filter, Model 6

A filter designed exclusively for direct collimation of the sun.

Solar filter of flap-up type.

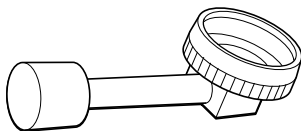

Diagonal eyepiece, Model 10

Observation in an easy posture will be provided up to the zenith position

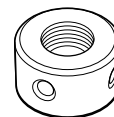

Solar reticle, Model 6

A reticle designed for collimation of the sun. Can be used together with Solar Filter.

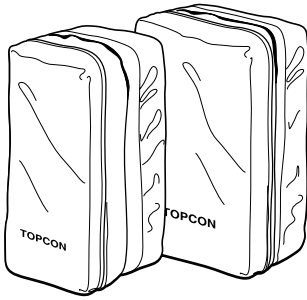

Prism unit case, Model 6

Fixed 9 prisms unit or tilting 3 prisms unit can be stored in this case. Especially, this is a very easy case to carry. Soft material is used.

- External dimensions:
250(L)×120(W)×400(H) mm
- Weight:0.5kg

Prism unit case, Model 5

1 prisms unit or fixed 3 prisms unit can be stored in this case. Especially, this is a very easy case to carry. Soft material is used.

- External dimensions:
200(L)×200(W)×350(H) mm
- Weight:0.5kg

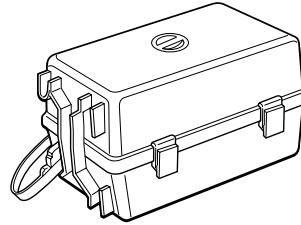

Prism unit case, Model 3

This is the plastic case to store and carry various sets of prisms.

The case covers one of the following prism sets:

- Tilt single prism set
- Tilt single prism set with a target plate
- Fixed triple prism unit
- Fixed triple prism unit with a target plate
- External dimensions:
427(L)×254(W)×242(H) mm
- Weight:3.1kg



Gadget case, Model 1

A case to store and carry accessories.

- External dimensions:
300(L)×145(W)×220(H) mm
- Weight:1.4kg

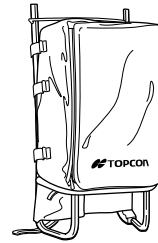

Back pack, Model 2

Convenient for use in mountainous terrain.

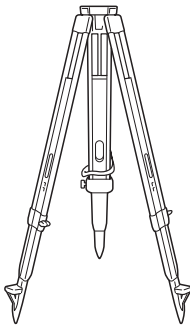

Aluminum extension leg tripod, Type E

- Flat head 5/8" × 11 threads with adjustable legs.

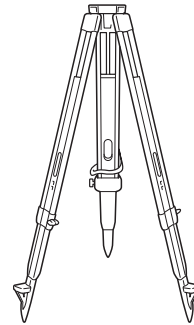

Wide-frame extension leg tripod, Type E (Wood)

- Flat head 5/8" × 11 threads with adjustable legs.

13 BATTERY SYSTEM

In case of On-board battery In case of External battery

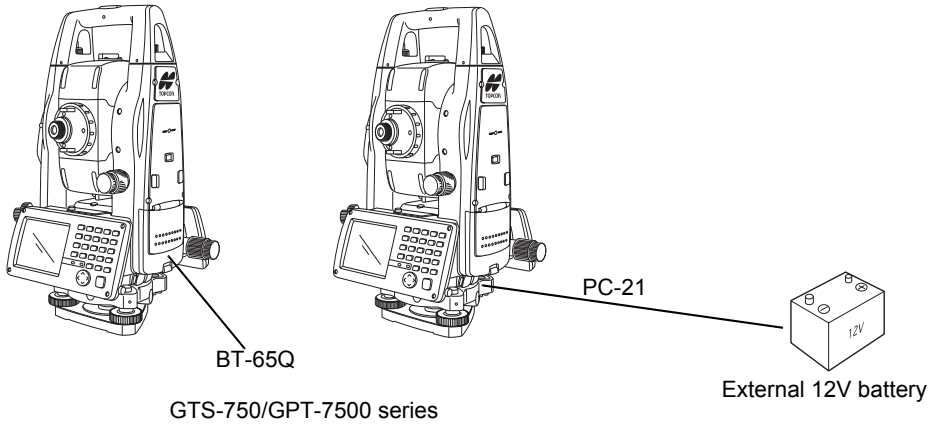

Charging

Charging time

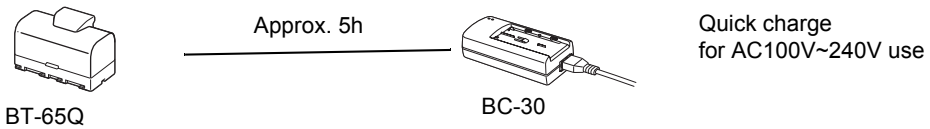

Note:

Use only recommended batteries or external power source.
Use of batteries or an external power source not recommended by us
may result in equipment failure.

14 PRISM SYSTEM

Arrangement according to your needs is possible.

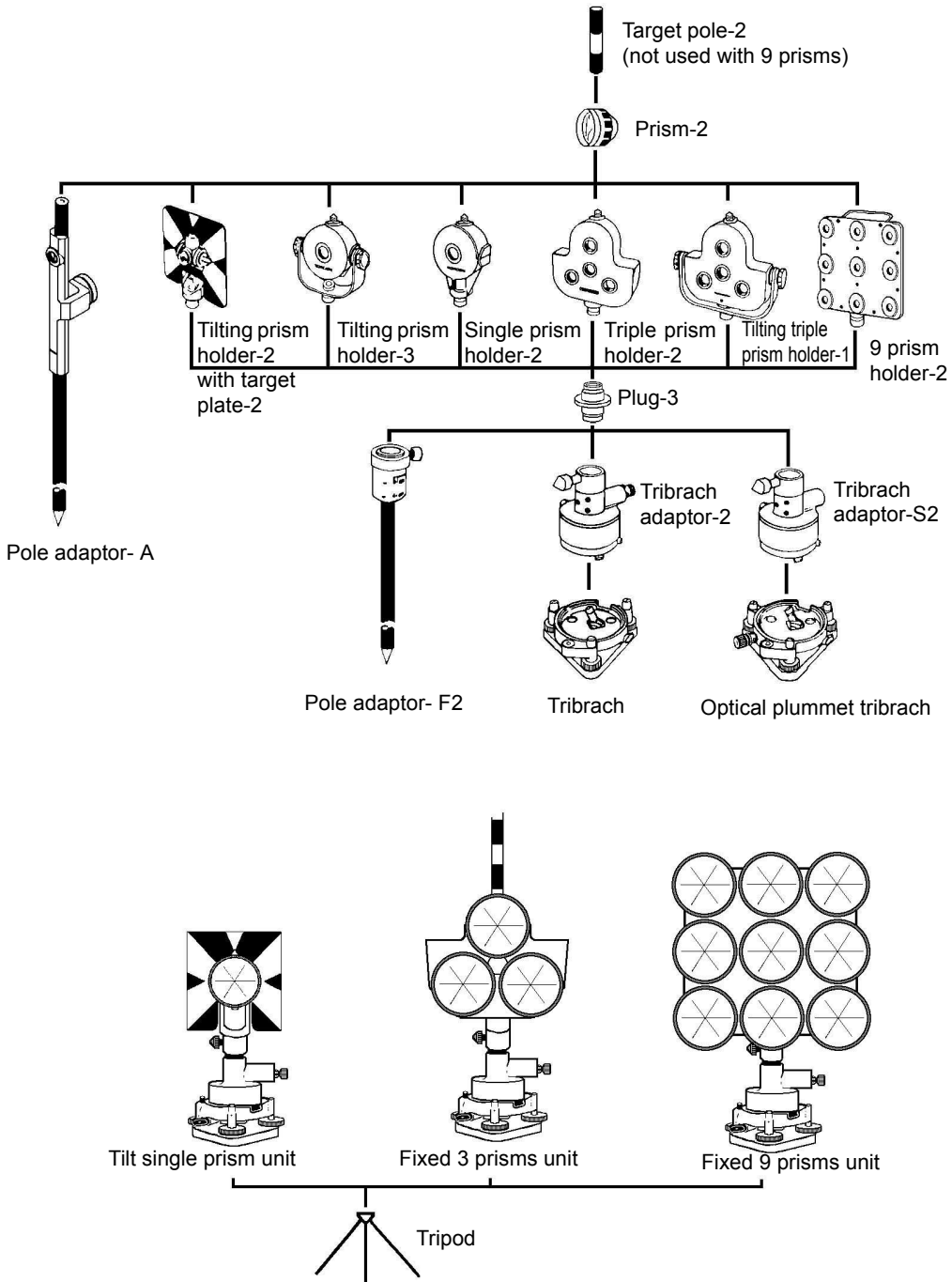

- Use the above prisms after setting them at the same height as the instruments. To adjust the height of prism set, change the position of fixing screws. Plug 3 is necessary for the tribrach adaptor-2, tribrach adaptor-S2 and pole adaptor-F2 to coincide with the height of GTS-750/GPT-7500 series.

15 PRECAUTIONS

- 1) For transportation, hold by the handle or yoke of the instrument. Never hold by the lens barrel as it can affect the fixing bracket inside and reduce the accuracy of the instrument.
- 2) Never expose the instrument without a filter to direct sunlight. It may damage the components inside the instrument.
- 3) Never leave the instrument unprotected in high temperature. The temperature inside instrument may easily reach up to 70°C or above and will reduce the service life.
- 4) When a high degree of precision is required for measurement, provide shade against direct sunlight for the instrument and tripod.
- 5) Any sudden change of temperature to the instrument or prism may result in a reduction of measuring distance range, i.e. when taking the instrument out from a heated vehicle.
- 6) When opening the carrying case and taking out the instrument, place the case horizontally, then open the case.
- 7) When returning the instrument to its case, be sure to match the white positioning marks provided with the case and place the instrument.
- 8) For transportation, provide dampening or a cushion appropriately to avoid sudden shock or vibration.
- 9) For cleaning the instrument after use, remove dust using a cleaning brush, then wipe off with a cloth.
- 10) For cleaning the lens surface, use a cleaning brush to remove the dust, then use a clean lintless cotton cloth. Moisten it with alcohol (or mixture with ether) to wipe gently in a rotational motion from the center out.
- 11) Even if any abnormality occurs, never attempt to disassemble or lubricate the instrument yourself. Always consult with TOPCON or your dealer.
- 12) To remove the dust on the case, never use thinner or benzine. Use a clean cloth moistened with neutral detergent.
- 13) Check each part of the tripod after extended use. Parts (screws or clamps) may work themselves free.

16 MESSAGE/ERROR DISPLAYS

16.1 Message

Message code	Description	Countermeasures
Please Input Value!	No value was entered at time of numerical value input.	Input numerical value.
Please Input Exact Value!	A value outside permissible range was input at time of numerical value input.	Input exact numerical value.
V Angle 0Set Error(Step1)	V angle 0-set is over. (in normal telescope)	Confirm the operation procedure is correct and adjust again.
V Angle 0Set Error(Step2)	V angle 0-set is over. (in reverse telescope)	
V Angle 0Set Over(Total)	V angle 0-set is over. (in normal and reverse telescope)	
V Angle Range Over	V angle range is over.	Adjust again from the beginning.
V Angle Offset Range Over	V angle offset range is over.	
V Angle Tilt Offset Range Over	V angle tilt offset range is over.	Level the instrument properly and adjust again.
Collimation constant Range Over	Collimation constant range is over.	
Horizontal angle axis constant Range Over	Horizontal angle axis constant range is over.	

16.2 Error

Error code	Description	Countermeasures
Data Read Error 01~27	The data could not be loaded.	Close the program and restart the instrument. If this error code continues to be displayed, repair is required.
Data Set Error 01~16	The data could not be set.	
EDM Offset Read Error	The EDM offset could not be loaded.	
EDM Offset Set Error	The EDM offset could not be set.	
Ext Communication Retry Error	The external communication could not be accomplished.	Confirm the operation procedure is correct. Confirm the cable connection is correct.
XTILT OVER	X tilt is over. Instrument tilts over more than 6 minutes.	Level the instrument properly.
YTILT OVER	Y tilt is over. Instrument tilts over more than 6 minutes.	
V-Angle Error	Displayed when the telescope rotated too fast.	There is no error.
H-Angle Error	Displayed when the instrument rotated too fast	If this error code continues to be displayed, repair is required
Tilt Error	Any abnormality occurs with Tilt sensor.	Repair is required.
E-60'	Any abnormality occurs with EDM.	
E-86 Internal Comm Error	Any abnormality occurs with the internal communication of the instrument.	Close the program and restart the instrument.
E-99	Any abnormality occurs with internal memory.	Repair is required.
LNP Range Set Error	-----	Close the program and restart the instrument. If this error code is consistently displayed, repair is required.
LNP Range Read Error	-----	
Prism Constant Set Error	-----	

- If error still persist after attempting to clear them, contact your local Topcon dealer or Topcon head office.

17 SPECIFICATIONS

Telescope

- Length : 150mm (GTS-750)
165mm (GPT-7500)
- Objective lens : 45mm (EDM 50mm)
- Magnification : 30x
- Image : Erect
- Field of view : 1°30'
- Resolving power : 2.8" (GTS-750)
3" (GPT-7500)
- Minimum focus : 1.3m
- Reticle illumination : Provided

Distance measurement

Measurement range (GTS-750 series)

Model	Prism	Atmospheric conditions	
		Condition 1	Condition 2
GTS-751 GTS-752 GTS-753	Mini prism	1,000m (3,300ft)	----
	1 prism	3,000m (9,900ft)	3,500m (11,500ft)
	3 prisms	4,000m (13,200ft)	4,700m (15,400ft)
	9 prisms	5,000m (16,400ft)	5,800m (19,000ft)
GTS-755	Mini prism	900m (3,000ft)	----
	1 prism	2,000m (6,600ft)	2,300m (7,500ft)
	3 prisms	2,700m (8,900ft)	3,100m (10,200ft)
	9 prisms	3,400m (11,200ft)	4,000m (13,200ft)

Condition 1: Slight haze with visibility about 20km (12.5miles) moderate sunlight with light heat shimmer.

Condition 2: No haze with visibility about 40km(25 miles), overcast with no heat shimmer.

Measurement range (GPT-7500 series)

- Prism mode

Prism	Atmospheric conditions	
	Condition 1	Condition 2
Mini prism	1,000m (3,280ft)	----
1 prism	3,000m (9,842ft)	4,000m (13,123ft)
3 prisms	4,000m (13,123ft)	5,300m (17,388ft)
9 prisms	5,000m (16,404ft)	6,500m (21,325ft)

Condition 1: Slight haze with visibility about 20km (12.5miles) moderate sunlight with light heat shimmer.

Condition 2: No haze with visibility about 40km(25 miles), overcast with no heat shimmer.

- Non-prism mode

Target	Atmospheric conditions
	In low light condition and without sun glare on target
Kodak gray card (White surface)	1.5m to 250 m (5 to 820 ft)

- Non-prism long mode

Target	Atmospheric conditions
	In low light condition and without sun glare on target
Kodak gray card (Gray surface, A square wall with sides of 0.5 meter)	5 to 700 m (16.4 to 2296 ft)
Kodak gray card (White surface, A square wall with sides of 1 meter)	5 to 2000 m (16.4 to 6561 ft)

Measurement accuracy/Least Count in Measurement/Measurement Time (GTS-750 series)

- Prism mode

D:Measuring distance

Measurement mode		Measurement accuracy	Least Count in Measurement	Measurement Time
Fine	0.2mm mode	$\pm (2\text{mm} + 2\text{ppm} \times D)$ m.s.e.	0.2mm (0.001ft)	2.8 sec. (Initial 5 sec.)
	1mm mode		1mm (0.005ft)	1.2 sec. (Initial 4 sec.)
Coarse	1mm mode	$\pm (7\text{mm} + 2\text{ppm} \times D)$ m.s.e.	1mm (0.005ft)	0.7 sec. (Initial 3 sec.)
	10mm mode		10mm (0.02ft)	
Tracking		$\pm (10\text{mm} + 2\text{ppm} \times D)$ m.s.e.	10mm (0.02ft)	0.4 sec. (Initial 3 sec.)

Measurement accuracy/Least Count in Measurement/Measurement Time (GPT-7500 series)

- Prism mode

D:Measuring distance

Measurement mode		Measurement accuracy	Least Count in Measurement	Measurement Time
Fine	0.2mm mode	$\pm (2\text{mm} + 2\text{ppm} \times D)$ m.s.e.	0.2mm (0.001ft)	3 sec. (Initial 4 sec.)
	1mm mode		1mm (0.005ft)	1.2 sec. (Initial 3 sec.)
Coarse	1mm mode	$\pm (7\text{mm} + 2\text{ppm} \times D)$ m.s.e.	1mm (0.005ft)	0.5 sec. (Initial 2.5 sec.)
	10mm mode		10mm (0.02ft)	
Tracking		$\pm (10\text{mm} + 2\text{ppm} \times D)$ m.s.e.	10mm (0.02ft)	0.3 sec. (Initial 2.5 sec.)

17 SPECIFICATIONS

- Non-prism mode (Diffusing Surface)

D:Measuring distance

Measurement mode		Measurement accuracy	Least Count in Measurement	Measurement Time *1)
Fine	0.2mm mode	± (5mm) m.s.e.	0.2mm (0.001ft)	3 sec. (Initial 4 sec.)
	1mm mode		1mm (0.005ft)	1.2 sec. (Initial 3 sec.)
Coarse	1mm mode	± (10mm) m.s.e.	1mm (0.005ft)	0.5 sec. (Initial 2.5 sec.)
	10mm mode		10mm (0.02ft)	
Tracking		± (10mm) m.s.e.	10mm (0.02ft)	0.3 sec. (Initial 2.5 sec.)

- Non-prism long mode *2)*3) (Diffusing Surface)

D:Measuring distance

Measurement mode		Measurement accuracy	Least Count in Measurement	Measurement Time
Fine	1mm mode	± (10mm +10ppm x D) m.s.e.	1mm (0.005ft)	1.5~6 sec. (Initial 6~8 sec.)
Coarse	5mm mode	± (20mm +10ppm x D) m.s.e.	5mm (0.02ft)	1~3 sec. (Initial 6~8 sec.)
	10mm mode		10mm (0.02ft)	
Tracking		± 100mm m.s.e.	10mm (0.05ft)	Approx. 0.4 sec. (Initial 4~7 sec.)

*1)The initial time will be different by a condition.

*2)However, when the measurement distance is more than 500 m, or when the reflectance of the measured surface is low, measurement time will become longer.

*3)Measurement distance: No more than 500m, When Kodak gray card (white surface) is used.

Laser class for distance measurement

: Class 1(IEC Publication 825)
: Class I(FDA/BHR 21 CFR 1040)

Atmospheric Correction Range

: -999.9 ppm to +999.9 ppm, in 0.1 ppm increments

Prism Constant Correction Range

: -99.9 mm to +99.9 mm, in 0.1 mm increments

Coefficient Factor

: Meter / Feet

International feet 1meter = 3.2808398501 ft.

US SURVEY feet 1meter = 3.2808333333 ft.

Electronic Angle Measurement

Method

: Absolute reading

Detecting system :

Horizontal

: 2 sides

Vertical

: 2 sides

Minimum reading

GTS-751/GPT-7501

: 1"/0.5" (0.5mgon/0.1mgon, 5mmil/2mmil) reading

GTS-752/GPT-7502/

GTS-753/GPT-7503/

GTS-755/GPT-7505

: 5"/1" (1mgon/0.2mgon, 20mmil/ 5mmil) reading

Accuracy(Standard deviation based on DIN 18723)

GTS-751/GPT-7501	: 1"(0.3mgon)
GTS-752/GPT-7502	: 2"(0.6mgon)
GTS-753/GPT-7503	: 3"(1.0mgon)
GTS-755/GPT-7505	: 5"(1.5mgon)

Diameter of circle : 71 mm

Tilt Correction

Type	: Automatic vertical and Horizontal index
Method	: Liquid type
Compensating Range	: $\pm 6'$
Correction unit	: 1"(0.1mgon)

Computer unit

Microprocessor	: Intel PXA255
Processor speed	: 400MHz
Operating system	: Microsoft® Windows® CE.NET 4.2
Memory	: 64MB / RAM 2MB Flash ROM 64MB SD Card

Display

LCD	: 3.5 inch TFT color LCD (240x320 dots)
Touch panel	: Electrical analog resistor thin film system

Interface

Based on RS-232C (6 pin)

Based on CompactFlash (Type I/II)*

*CompactFlash is a trademark of SanDisk corporation.

USB	: Type miniB Rev.1.1(Active Sync) Type A Rev.1.1(USB Memory)
-----	---

Others

Instrument height : 196mm (7.7in) Base unit detachable
(Height from the tribrach dish to the center of telescope)

Level sensitivity	
Circular level	: 10"/2mm
Plate level	: 30"/2 mm

Optical Plummet Telescope

Magnification	: 3×
Focusing range	: 0.5m to infinity
Image	: Erect
Field of view	: 4°

Laser pointer (GPT-7500)

Light source	: LD (Visible laser)
Wave length	: 690nm
Out put	: 1mW maximum
Laser class	: Class 2(IEC Publication 825) : Class II(FDA/BHR 21 CFR 1040)

Dimension (With tribrach)

GTS-751/752/753, GPT-7501/7502/7503	: 377 (H) × 223 (W) × 201 (L) mm (14.8 (H) × 8.7 (W) × 7.9 (L) in)
GTS-755, GPT-7505	: 377 (H) × 223 (W) × 185 (L) mm (14.8 (H) × 8.7 (W) × 7.2 (L) in)

17 SPECIFICATIONS

Weight

Instrument	GTS-750	: 5.9 kg (12.9 lbs)
	GPT-7500	: 6.6 kg (14.2 lbs)
Battery(BT-65Q)		: 0.2 kg (0.4 lbs)
Carrying case		: 4.5kg (9.9 lbs)

Durability

Protection against water and dust	: IP54 (Based on the standard IEC60529)
Ambient Temperature Range	: -20°C to +50°C (-4°F to +122°F)

External Battery

Input voltage	: DC12 V
---------------	----------

Rechargeable Battery BT-65Q (This battery does not contain mercury.)

Output voltage	: DC7.4 V
Capacity	: 5000mAh
Maximum operating time (when fully recharged) at +20°C (+68°F)	
Including distance measurement	
GTS-750	: Approx. 10.0 hours
GPT-7500	: Approx. 6.0 hours
Angle measurement only	
	: Approx. 12hours

Battery Charger BC-30

Input voltage	: AC 100-240V
Frequency	: 50/60Hz
Recharging time (at +20°C /+68°F)	
Battery BT-65Q	: 5 hours
Operating temperature	: +10°C to +40°C (+50°F to 104°F)
Charging signal	: Red charge lamp should glow
Finishing signal	: Red charge lamp should go out
Weight	: 0.15kg (0.3 lbs)

- Battery using time will vary depending on environmental conditions and operations done with GTS-750/GPT-7500 series.

18 APPENDIX

1 Dual Axis Compensation

Inclination of the vertical axis with respect to true vertical will result in incorrectly measured horizontal angles. The extent of the error in horizontal angle measurement due to axis tilt depends on three factors :

- the amount of the tilt of axis
- the elevation of the target
- the horizontal angle between the direction of tilt of the vertical axis and the target.

These factors are related by the following formula :

$$Hz_{err} = V \cdot \sin \alpha \cdot \tan h$$

where v = tilt of axis in arcseconds

α = azimuth angle between vert. axis direction and target

h = elevation of target

Hz_{err} = error in horizontal angle

Example: When the vertical axis is tilted by 30 arcseconds, the target is 10° above the horizon and rotated 90 in azimuth from the direction of the vertical axis error.

$$Hz_{err} = 30'' \cdot \sin \alpha \cdot \tan 10^\circ$$

$$Hz_{err} = 30'' \cdot 1 \cdot 0.176326 = 5.29''$$

From the above example it can be seen that horizontal angle errors will increase with steeper vertical sights (tangent will increase as vertical angle increases) and will be at a maximum when the target is at right angles ($\sin 90^\circ = 1$) to the direction of the vertical axis error. Errors will be at a minimum when the sights are nearly horizontal ($h=0$, $\tan 0=0$) and in the same direction as the vertical axis error ($\alpha=0$, $\sin 0=0$). Please refer to the table below to see the relationship between axis tilt (v) and elevation (h) and the error in horizontal angles which results from these factors.

h	0°	1°	5°	10°	30°	45°
V						
0"	0"	0"	0"	0"	0"	0"
5"	0"	0.09"	0.44"	0.88"	2.89"	5"
10"	0"	0.17"	0.87"	1.76"	5.77"	10"
15	0"	0.26"	1.31"	2.64"	8.66"	15"
30"	0"	0.52"	2.62"	5.29"	17.32"	30"
1'	0"	1.05"	5.25"	10.58"	34.64"	1'

It is clear from the table that dual axis compensation has the most benefit when the elevation of the target is greater than 30° and the axis is tilted more than $10''$. The entries indicated in bold in the table show, in fact, that for many common surveying applications i.e. target elevation $<30^\circ$ and axis error $<10''$, virtually no correction would be required. Dual axis compensation is especially suited then for applications where the sights are very steep.

Even though the compensators can correct horizontal angles for vertical axis errors, ***it is still important to use care in setting up the instrument.***

Centering error, for instance, cannot be corrected by the compensators. If the vertical axis is tilted by $1'$ with the instrument 1.4 meters above the ground, a centering error of approx. 0.4mm will result. The maximum effect of this error at 10m is about $8''$ of horizontal angle error.

In order to maintain the increased accuracy possible through dual axis compensation, it is necessary to keep the compensators in proper adjustment. The compensators must agree with the actual level condition of the instrument. Through various environmental stresses, the agreement between the level condition sensed by the compensators and the true level condition of the instrument may be disturbed. In order to reestablish the correct relationship between the compensator and the true level condition of the instrument, it is necessary to carry out the vertical indexing procedure listed on Section 6.3.6 "Adjustment of Vertical Angle 0 Datum". This adjustment will both reset the vertical index (cause a direct + indirect zenith reading to the same elevation to equal 360°) and zero the level reference for the horizontal compensator. While correct vertical angles can be obtained by averaging direct and indirect reading even when the index is improperly adjusted, the same is not true for horizontal angles. Since the vertical axis error is fixed for a given setup, its effect cannot be removed by averaging two readings. ***For this reason, it is extremely important to maintain the vertical indexing adjustment to insure proper correction of the horizontal angles.***

19 INDEX

A

Active Sync	51
Angle Measurement	52
Angle measuring mode	29
Auto Power Off	36

B

Backlight Adjustment	15
Battery Power Remaining Display	42
BATTERY SYSTEM	117

C

CHARGING	112
CHECK AND ADJUSTMENT	86
Coordinate Measurement	66
Coordinate measuring mode	29
correction for earth curvature	111
correction for refraction	111

D

Data Output	70, 71
Distance Measurement	56
Distance measuring mode	29

E

ERROR DISPLAYS	120
----------------------	-----

F

Function Key (Soft Key)	28
-------------------------------	----

H

Hardware Reset	23
How to Enter Numerals and Alphabet Letters	46
How to Set the Instrument Constant Value	100

I

Instrument Constant	86
---------------------------	----

L

Laser Pointer	33, 92
---------------------	--------

M

Main Menu Contains	12
Memory Card	50

O

Operating Panel Key	26
Optical Plummet Telescope	98

P

PARAMETERS SETTING MODE	82
Point guide ON/OFF	31
POWER SOURCE AND CHARGING	112
Power OFF	27
PRISM / NON-PRISM CONSTANT VALUE	104
Prism mode and Non-prism mode	56

R

Reticle illumination	32
RAM Data Backup	20

S

Set audio mode (S/A mode)	32
SETTING ATMOSPHERIC CORRECTION	105
Shortcut Keys	14
Software Reset	14
Stake Out (S.O)	64
Star Key Mode	30

T

Task Manager	14
Touch Panel Calibration	24
TRIBRACH	114

V

Vertical Angle Percent Grade(%) Mode	55
--	----



EMC NOTICE

In industrial locations or in proximity to industrial power installations, this instrument might be affected by electromagnetic noise. Under such conditions, please test the instrument performance before use.

This is a CLASS A product. In a domestic environment this product may cause radio interference in which case the user may be required to take adequate measures.

TOPCON CORPORATION

75-1 Hasunuma-cho, Itabashi-ku, Tokyo 174-8580, Japan
Phone: 3-3558-2520 Fax: 3-3960-4214 www.topcon.co.jp

©2007 TOPCON CORPORATION
ALL RIGHTS RESERVED