

XPR2 PowerStations

The New Generation Affordable and Enhanced Reliability PowerStations for Interact Xpress



Joining the Xpress family of “Information Anywhere” PowerStations, the XPR2 sets a new standard as a durable and affordable platform for Interact Xpress HMI applications. Newly added robustness and reliability features include:

- Solid State CompactFlash based mass storage
- Fan-less convection cooling
- Elimination of all moving parts for enhanced reliability and long-term service

These design enhancements place the XPR2 among the most rugged and reliable Interact Xpress PowerStations ever!



Contact Information:

Parker Hannifin Corporation
Electromechanical Automation Division
 5500 Business Park Drive
 Rohnert Park, CA 94928
phone 800.358.9068
www.parkermotion.com/HMI



Performance Features		
CPU		AMD LX800 (500 MHz)
DRAM		256 MB
Hard Drive		512 MB CompactFlash
Display Size	Resolution	Model Number
No Display	—	XPR200XN-2P3
6" Display	VGA (640 x 480)	XPR206VT-2P3
8" Display	VGA (640 x 480)	XPR208VT-2P3
10" Display	VGA (640 x 480)	XPR210VT-2P3
15" Display	XGA (1024 x 768)	XPR215XT-2P3 XPR215AT-2P3*

* Stainless steel bezel



The second generation XPR2 PowerStation family offers a hardware/software solution that is optimized for harsh environments.

The XPR2's Interact Xpress™ HMI software is designed specifically to simplify and cost reduce HMI applications. Interact Xpress takes full advantage of the internet and the wide availability of web browsers to design, publish, run and support your HMI applications without the cost and complexity of desktop Windows software and hardware.

The bundled Xpress HMI runtime software offers the flexibility of Adobe Flash™ based web publishing that allows you to run, view and even edit your HMI application from anywhere.

XPR2 Features

All XPR2 models are designed to be the perfect complement to our Interact Xpress HMI software by offering a rugged industrial design with core features including:

- **No display, 6", 8", 10.4" and 15" touchscreen displays**
- **Slim profile with consistent features**
- **Interact Xpress HMI software**
- **CompactFlash storage**
- **AMD LX-800 CPU**
- **2 USB ports**
- **2 Serial ports**
- **100BaseT Ethernet port**
- **Multiple control device connectivity**
- **Quick and easy clip mounting**
- **NEMA 4X rating**
- **24 VDC power**



ENGINEERING YOUR SUCCESS.

XPR2 PowerStation Specifications

Features	XPR200	XPR206	XPR208	XPR210	XPR215	
Size	XPR200 has no display, but is pre-configured with a standard XGA output.	6" Color TFT 5.7" Diagonal	8" Color TFT 7.5" Diagonal	10" Color TFT 10.4" Diagonal	15" Color TFT 15" Diagonal	
Resolution		VGA (640x480)	VGA (640 X480)	VGA (640 x 480)	XGA (1024 x 768)	
Display	Viewing Angle	Can be used with our PHM Family monitors to create a "split" system	±80° L/R 80° U, 70° D	±70° L/R 60° U, 65° D	±70° L/R 50° U, 60° D	±80° L/R 80° U, 60° D
	Brightness		350 NIT	400 NIT	200 NIT	250 NIT
	Bulb Life (hrs)		75,000	50,000	50,000	40,000
Weight (lbs)	2.0	2.6	4.1	8.4	13.8	
Dimensions Inches (HxWxD)	6.05 x 4.12 x 2.52	6.00 x 7.40 x 2.99	7.60 x 10.20 x 3.06	11.00 x 13.78 x 4.01	13.30 x 16.80 x 5.19	
Interface	Analog Resistive Touchscreen					
Power Requirement*	12/24VDC @ 18W (Range: min 11 VDC, 28 VDC Max)		24 VDC @ 22W (Range: min 18 VDC, 28 VDC max)			
HMI Software	Interact Xpress embedded development and runtime (pre-installed)*					
Processor	AMD LX800 (500 MHz)					
CompactFlash Storage	512 MB CompactFlash (Minimum- Actual storage volumes may be higher)					
Ports	Keyboard	USB 2.0				
	Mouse	USB 2.0				
	USB	(2) USB 2.0, Type A				
	Serial	(1) RS-232, (1) RS-232/422/485				
	Ethernet	(1) 10/100Base-T w/ RJ45				
Environment	Temperature	0 – 50°C				
	Rel. Humidity	5-95% (non-condensing)				
	Vibration	10-500 Hz 2grms (Random)				
	Shock	10G, 11 msec (operating); 30G, 11 msec (non-operating)				
Agency Approval	CE; UL/CUL, NEMA 4X (Indoor Only); Class 1 Div. 2 (Available as an option)					



*Units use P1X-PWARC power supply which can be mounted on back of 10" and 15" units.

XPR2 Ordering Information

Order Example:	①	②	③	④	⑤
	XPR2	00XN	-	2	P
					1

Select an option from each numbered field to create a complete model order code.

① Series XPR2 Industrial PC	③ Processor 2 AMD LX800 500MHz	⑤ Agency Approval 1 No approvals 3 UL/CUL/CE 5 UL/CUL/CE Class 1 Div 2
② Display 00XN No-display 06VT 6" VGA (640x480 pixels) 08VT 8" VGA (640x480 pixels) 10VT 10" VGA (640x480 pixels) 15XT 15" XGA (1024x768 pixels) 15AT 15" XGA Stainless Bezel (1024x768 pixels)	④ CompactFlash Storage P 512 MB	

Cutout Dimensions

XPR200

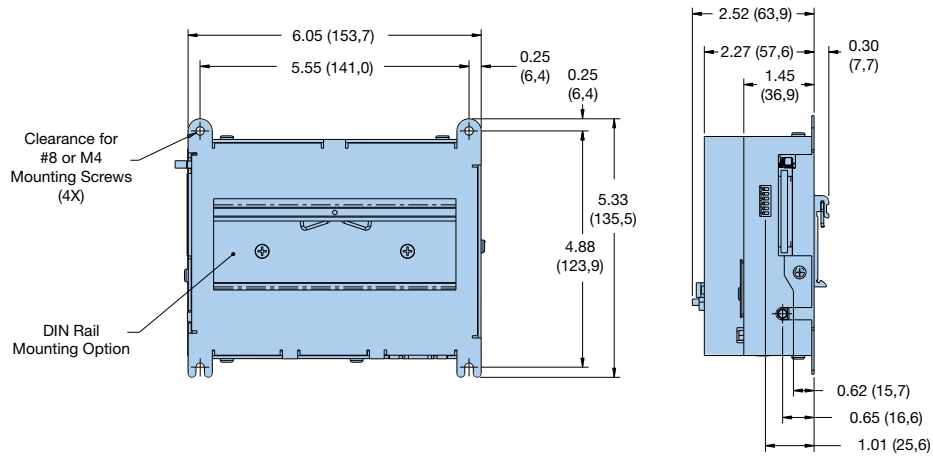

XPR206

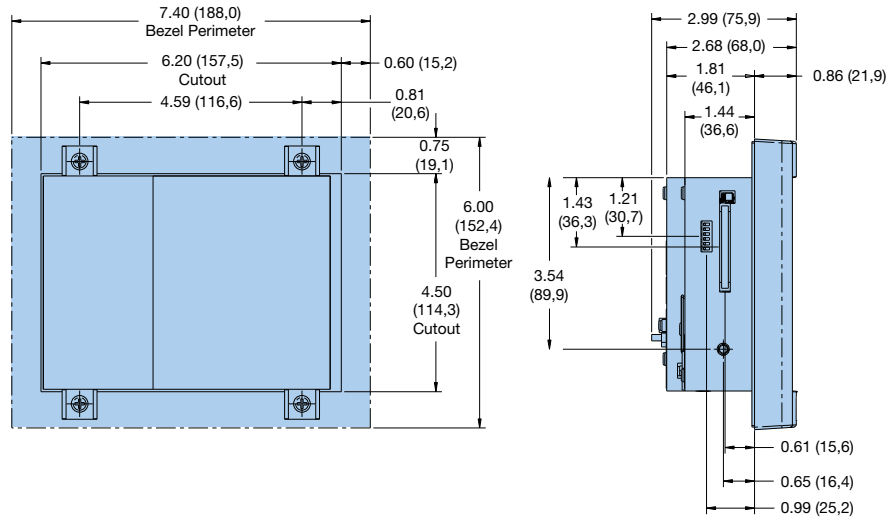

XPR208

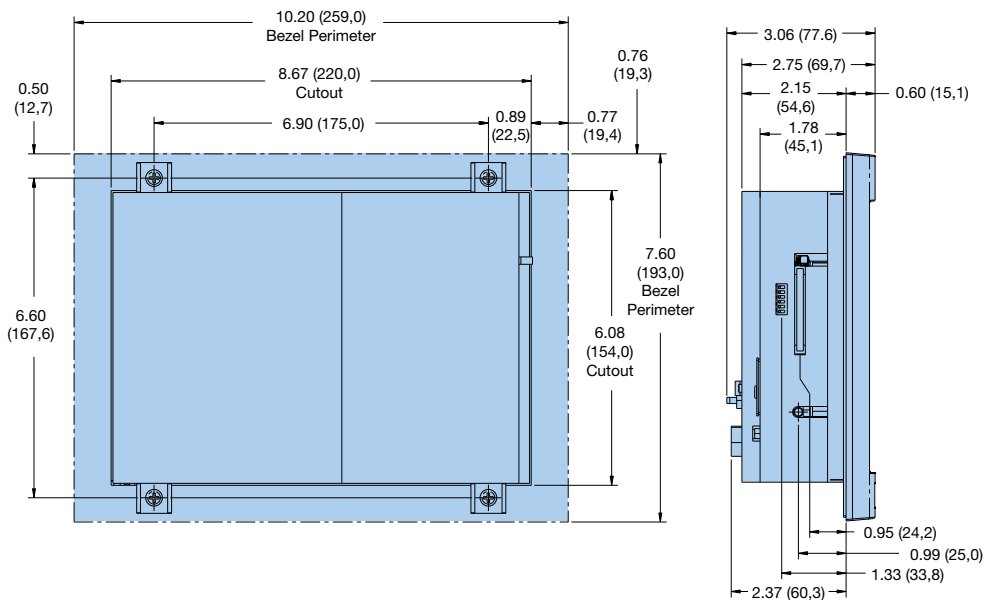

Cutout Dimensions

XPR210

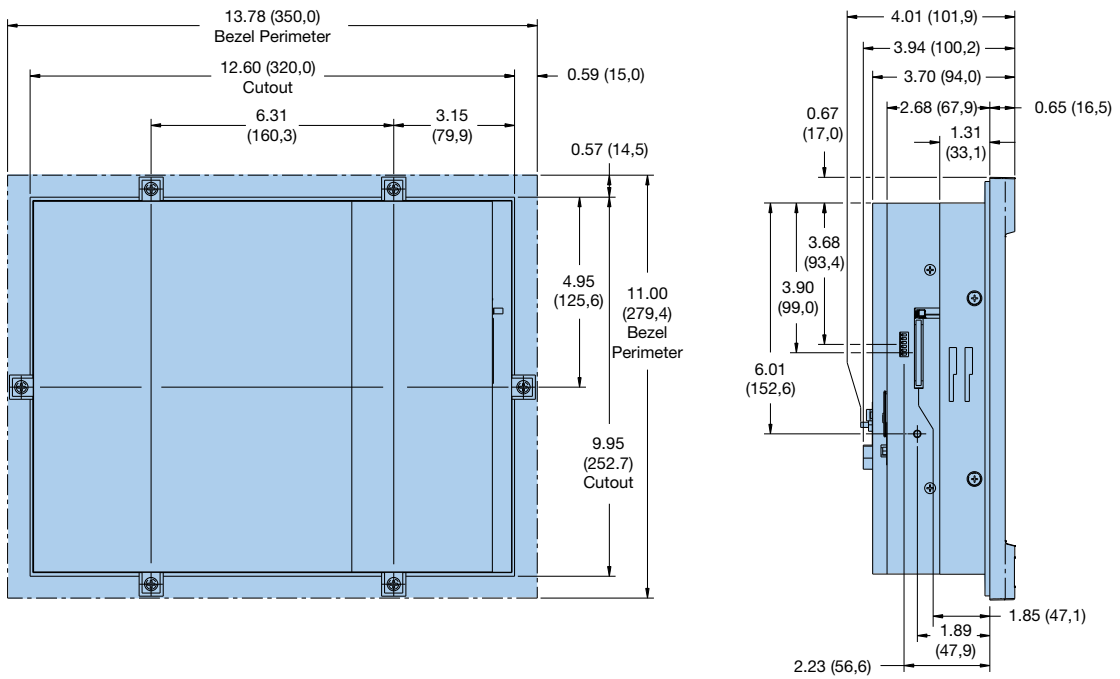

XPR215

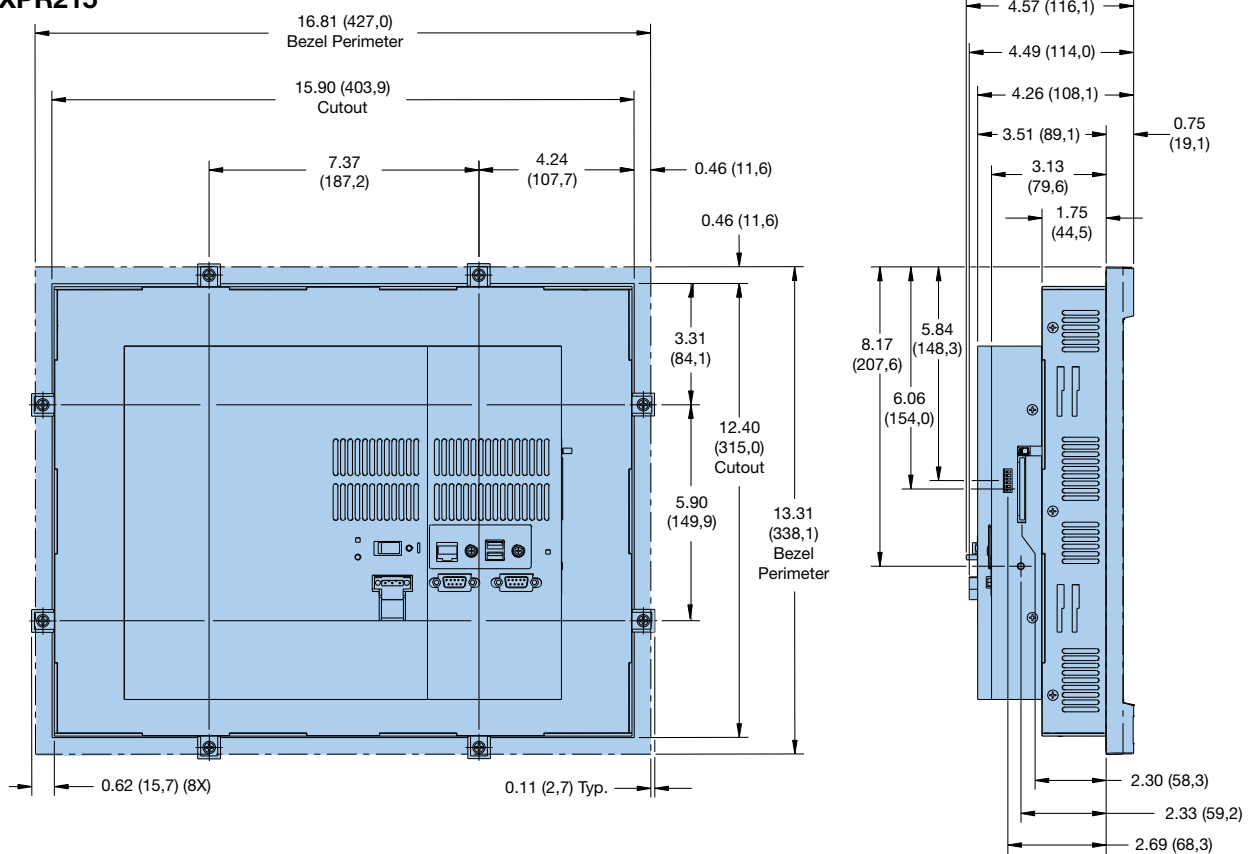

ENGINEERING YOUR SUCCESS.