



aerospace  
climate control  
**electromechanical**  
filtration  
fluid & gas handling  
hydraulics  
pneumatics  
process control  
sealing & shielding



# Motion Solutions

For Food Processing and Packaging Machinery

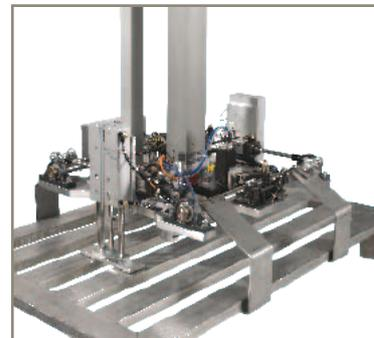

VICPAS  
HMT Parts Center

ENGINEERING YOUR SUCCESS.



**WARNING – USER RESPONSIBILITY**

**FAILURE OR IMPROPER SELECTION OR IMPROPER USE OF THE PRODUCTS DESCRIBED HEREIN OR RELATED ITEMS CAN CAUSE DEATH, PERSONAL INJURY AND PROPERTY DAMAGE.**

- This document and other information from Parker-Hannifin Corporation, its subsidiaries and authorized distributors provide product or system options for further investigation by users having technical expertise.
- The user, through its own analysis and testing, is solely responsible for making the final selection of the system and components and assuring that all performance, endurance, maintenance, safety and warning requirements of the application are met. The user must analyze all aspects of the application, follow applicable industry standards, and follow the information concerning the product in the current product catalog and in any other materials provided from Parker or its subsidiaries or authorized distributors.
- To the extent that Parker or its subsidiaries or authorized distributors provide component or system options based upon data or specifications provided by the user, the user is responsible for determining that such data and specifications are suitable and sufficient for all applications and reasonably foreseeable uses of the components or systems.

<b>Our Packaging Focused 360° Offer .....</b>	<b>4</b>
<b>Mechatronic Problem-solving Skills .....</b>	<b>6</b>
Reduced design time .....	7
Improved time-to-market .....	7
Faster changeovers.....	7
Higher output and plant efficiency .....	7
<b>International Standards.....</b>	<b>8</b>
<b>References.....</b>	<b>8</b>
<b>Success Stories.....</b>	<b>9</b>
Sponge cake and waffle machine .....	10
Slicing machine for meat portioning .....	10
Piston filling machine for pasty products.....	11
Auger filler for powdery products.....	11
Capping machine for PET bottles .....	12
Tray sealing machine .....	12
Horizontal flow wrapping machine.....	13
Form, fill and seal machine for coffee pads.....	13
Labeling machine.....	14
Carton folding and glueing machine .....	14
Cartoner and case packer.....	14
Sync gates in bottle handling systems .....	15
Turnkey palletizing robots as a complete system .....	15

# Our Packaging Focused 360° Offer

Parker offer bespoke solutions to meet all of your motion control needs

## HMIs and operator panels

- Text based panels
- Graphical touch panels
- Multi-client web server for remote diagnostics
- User management offering FDA CFR21 / Part 11 compliance



## Cylindrical linear motor actuators

- Cost-optimized plug & play solution
- IP67 option
- Infeed applications
- Ejector applications
- Filling and dosing applications
- Pick and place applications
- Product alignment applications



## Technology Functions

- Electronic line shaft (ELS)
- Electronic Gearbox (Gearing)
- Electronic Cams
- Electronic Cam switches
- Print mark synchronization
- Winding
- Rotating cutter and flying shear / cut on the fly

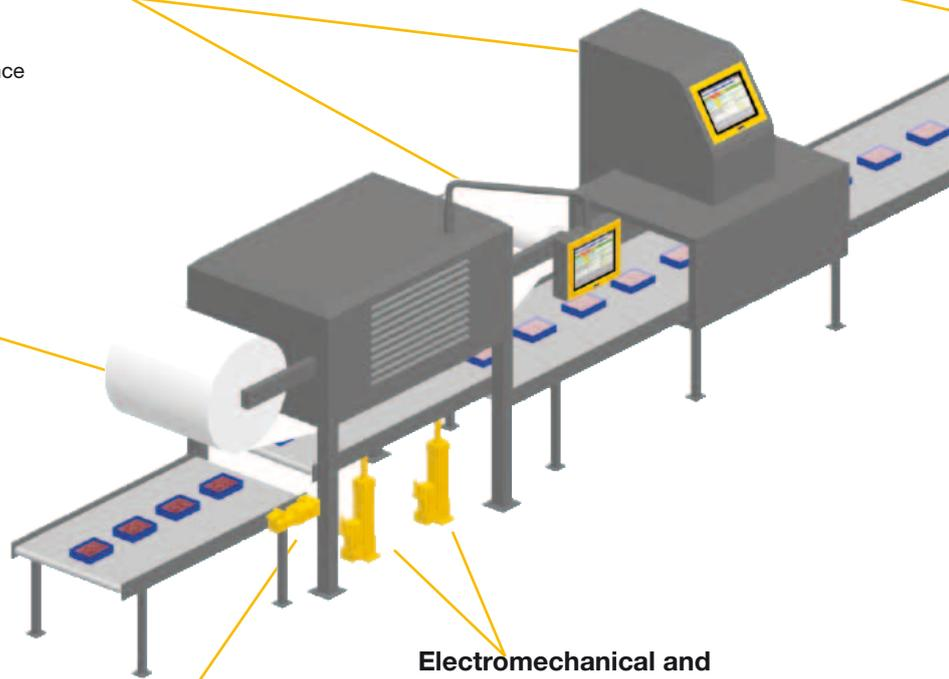
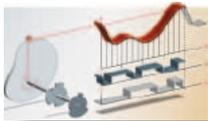

## Electromechanical and Pneumatic Cylinders

- Ballscrew actuator optimized for vertical applications
- IP65 option
- Lifting applications
- Press applications
- Flying shear applications
- Handling applications



## Global Air Preparation

- 3 distinct sizes
- Body ported & fully modular
- Metal bodies with choice of metal or plastic bowls
- Soft-start & quick dump valves
- 5 micron filtration as standard



## Rotary Servo Motors and Motors with Integrated electronics

- Variety of motor feedback systems
- High dynamics and low rotor inertia
- ATEX motors
- Motors with integrated drive electronics



+

## Gearheads

- Low noise operation
- Fitting in any plane possible
- Life time lubrication
- Easy adaptation to different mechanical systems



- PUR seals for long service life
- Corrosion resistant design
- Lubricated with food grade grease
- Magnetic piston as standard
- Simple installation and mounting



### Complete Subsystems

- Application specific subsystems for handling and pick & place
- Standard or customized solutions
- Optional integration of pneumatic axes

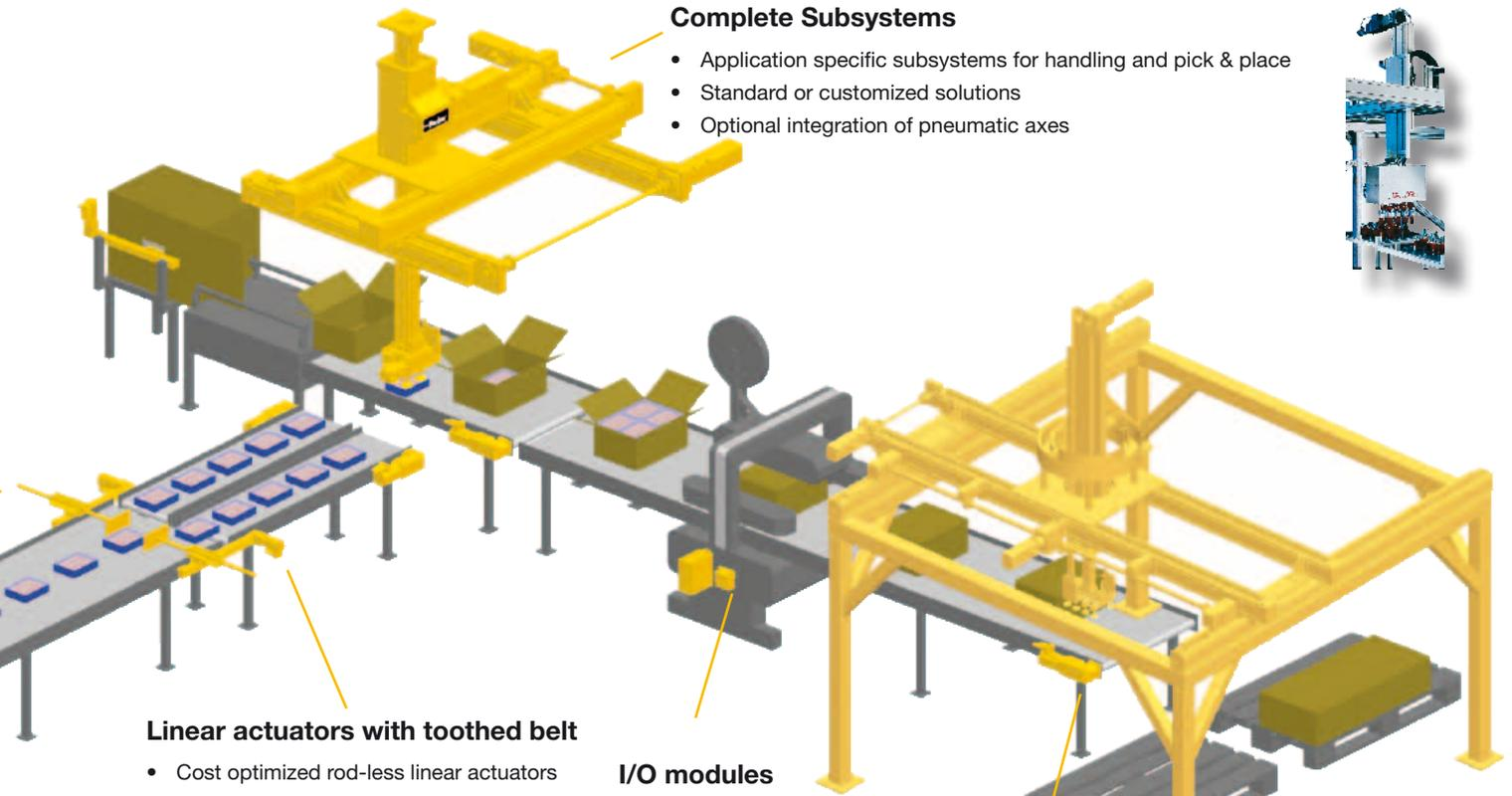

### Linear actuators with toothed belt

- Cost optimized rod-less linear actuators
- Food grade
- Infeed applications
- Removal handling applications
- Ejector applications
- Cut on the fly applications
- Pick and place applications

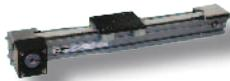

### I/O modules

- Decentralized I/O modules
- All common fieldbusses
- Simple mounting and cabling



### Rodless Pneumatic Cylinders

- Parker's Origa rodless cylinder takes high loads and moments and are available in many special versions for the demanding requirements of packaging applications



### Complete gantry robots

- X-Z line gantries
- X-Y-Z gantries
- Optional rotary axis modules
- Complete systems including all components & software
- Short lead time



### Logic and motion controllers

- IEC61131-3 controllers
- Optimized motion controllers
- Application software

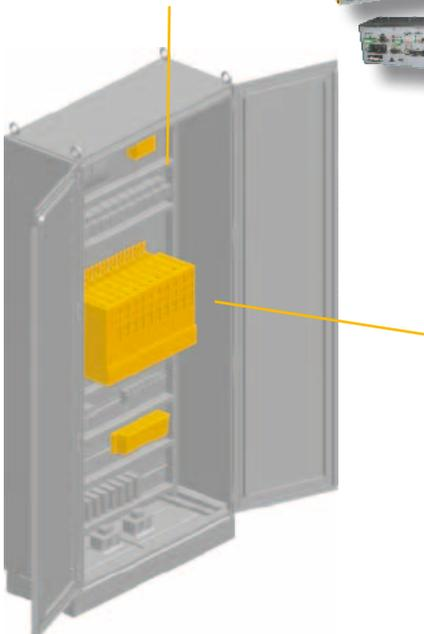

### Isys Micro

- Up to 32 solenoids per valve island
- Wear compensating seal system, 50 million cycles +
- 4 valves mounted back to back in 42 mm width
- Front or bottom ported manifolds
- Profbus DP, CANopen & DeviceNet protocols

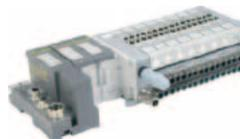

### Servo drives, stepper drives, frequency inverters

- Highly dynamic drives
- Cost optimized drives
- Drives for format changes and supply movements
- Safety drive technology
- Simple device changeover
- Decentralized and centralized concepts
- Size-optimized multi axis controllers to reduce cabinet space
- All common fieldbusses



# Mechatronic Problem-solving Skills

Helping you to meet the challenges you face every day

Convenience products and flexible package sizes are in demand more than ever. This in turn results in reduced batch sizes. A key challenge of today's machines is to design machines that combine flexible and quick format changes with high cycle rates and low life cycle costs.

Parker has been supporting food processing equipment and packaging machinery manufacturers for more than 15 years in:

- Electric drive and control technology
- Pneumatic control technology
- Electromechanical linear actuators
- Pneumatic actuators
- Linear motor technology
- Application software
- Handling and palletizing solutions

Thanks to our drive technology, mechanical and application specific know-how, we are the ideal partner to help you meet the mechatronic challenges posed by your customers. Our offer comprises:

- **Standard products**
- **Customized solutions**
- **Sub-system and system solutions**



Parker offers support throughout all stages of your project



Machine for waffle and sponge cake production

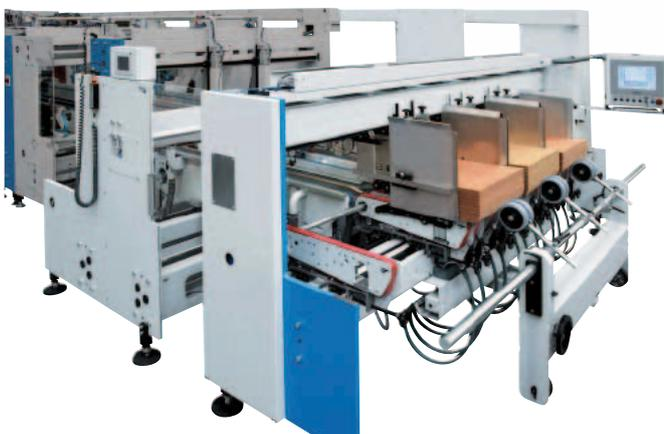

Machine for erecting carton blanks

## Reduced design time



- Thanks to proven food grade standard linear actuators, in-house development become redundant
- CAD data for all components
- Component sizing & selection including application engineering
- Customer specific adaptations and developments
- Servo technology with autotuning and plug & play
- Support for all common programming and communication standards

## Improved time-to-market



- Solutions reducing control cabinet and machine footprint and minimizing wiring overhead
- Complete mechatronic systems consisting of drive, motor and actuator
- Pre-engineered mechanical and mechatronic sub systems
- Common platform for centralized and decentralized architectures depending on the machine type

## Faster changeovers



- High levels of flexibility thanks to purely electronic axis synchronisation and coupling and electronic line shaft
- Fast changeovers thanks to flexible stepper motor technology and cost optimized servo drives
- Actuators for changeover applications

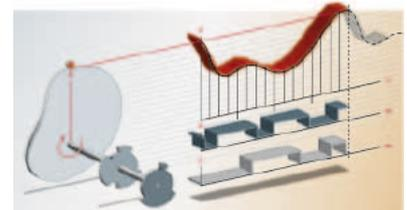

## Higher output and plant efficiency



- Higher cycle rates thanks to optimized systems with servo technology and electromechanical actuators from one source
- Powerful and maintenance free linear motor technology
- Simple device swap-out in case of maintenance
- Flexible service intervals thanks to condition monitoring
- Higher overall equipment efficiency (OEE) and reduced downtimes thanks to single vendor product connection and network communications

# International Standards

Our consistent focus on international standards guarantees easy handling and optimized return on investment



# References

Renowned companies trust Parker to deliver reliable products and system solutions for their machines

- Henkel
- Nestlé
- Unilever
- Procter & Gamble
- Philips
- Danone
- L’Oreal
- Storck
- Ferrero
- TetraPak
- Coca Cola
- Master Foods
- Johnson & Johnson
- Kraft Foods
- Novartis
- Bayer
- Pfizer
- Philip Morris
- Kimberly Clark
- GlaxoSmithKline
- Colgate Palmolive
- Müller Milch
- Hershey
- Merck



# Success Stories

Here are some of Parker's Success Stories demonstrating our capabilities in food processing and packaging machinery construction

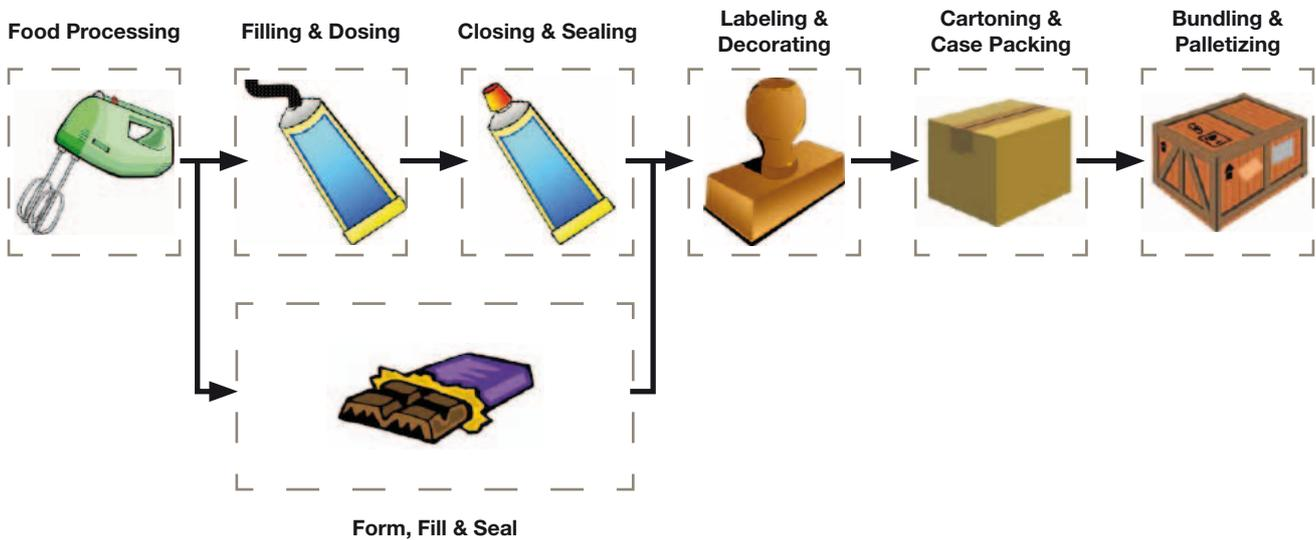

Field of application	→ Typical applications	→ Parker success story
<b>Food Processing</b>	→ Machinery for producing and processing food	→ Sponge cake and waffle machine Slicing machine for meat portioning
<b>Filling &amp; Dosing</b>	→ Machines for filling and dosing of liquid, powder, pasty and solid products	→ Piston filling machine Auger filling machine
<b>Closing &amp; Sealing</b>	→ Machines for closing or sealing filled primary packages	→ Lid sealer capping machine for PET bottles Tray sealer
<b>Form, Fill &amp; Seal</b>	→ Machines combining several processes such as form, fill and sealing machines	→ Horizontal flow wrapping machine Form/fill/seal machine for coffee pads
<b>Labeling &amp; Decorating</b>	→ Machines for decorating, labeling and coding packages	→ Labeling machine
<b>Cartoning &amp; Case Packing</b>	→ Machines for erecting folding cartons and filling them with one or multiple primary packages	→ Carton folding & glueing machine Case packer
<b>Bundling &amp; Palletizing</b>	→ Machines bundling and/or stacking secondary packages on pallets	→ Sync gate in a bottle handling system Parker turnkey palletizing robot

# Sponge cake and waffle machine

## Food Processing



Precisely cut waffles thanks to electro thrust cylinder and servo drive

### Many rejects due to complicated cutting processes

A manufacturer of machinery for the production of waffles faced customers complaining about too many defective products. The cause was the complicated cutting process of the dry and brittle waffle products resulting in product breakage.

### Electro thrust cylinder and servo drive with special motion profile

In cooperation with Parker they developed a mechatronic solution using a highly dynamic electro thrust cylinder pushing the product through a fixed cutting grid. Thanks to the special motion profile of the cylinder, the breakage rate could be considerably reduced. The solution was realized via decentralized servo drives which can be seamlessly integrated into the customer's proven control architecture via Profibus. In order to prevent the inevitable waffle dust from entering the body of the electro thrust cylinder, Parker developed an application specific sealing system with air purge at the thrust rod outlet for this customer.

### Shorter cycle times and reduced product wastage

This results in shorter cycle times, a dramatically reduced number of rejects and an increased total plant efficiency due to more than 43 000 precisely controlled double strokes per day.

# Slicing machine for meat portioning

## Food Processing



Bacon cut with electro thrust cylinder

### Opening new markets with reduced engineering overheads

In order to open new markets in the fully automated high power segment, a manufacturer of cutting machines for the production of bacon rashers was planning a new generation of machine. At the same time, they wanted to reduce their engineering overheads. In order to reach this goal, they decided to use electromechanical standard actuators instead of in-house engineering solutions. The standard products were however not suitable for the environmental conditions and the wet cleaning procedures.

### Food grade electromechanical solution

Parker was able to offer a food grade solution with an IP 65 electro thrust cylinder. The cylinder pushes the bacon parts through a fixed multiple grid cutter. After a stroke of 30 mm, a cross cutting unit cuts the rashers. The electro thrust cylinder works with a thrust force of 10 000 N. A new stroke is advanced every 0.2 seconds. After 20 strokes, the cylinder will return to its initial position. The solution is complemented by a servo drive and control technology perfectly matched to the mechanical system from one source without interface issues.

### The new machine produces 350 cuts per minute

Thus, the customer was able to quickly develop and introduce a new cutting machine into the market delivering over 350 cuts per minute.

# Piston filling machine for pasty products

## Filling & Dosing



Precisely dosed fruit yogurt

### Dosing precision poses a problem

A machine manufacturer offering dosing systems for liquid and pasty products wanted to improve the dosing precision of their piston filling pumps and to ensure the gentle handling of the products to be dosed.

The inaccuracies were due to the poor positioning properties of their traditional solution.

### Electro thrust cylinder and decentralized servo drive enhance precision

In cooperation with Parker, the existing traditional solution was replaced by an IP65 electro thrust cylinder driving the pump piston. In combination with a Parker servo drive controller, this allows for extremely delicate and precisely repeatable dosing.

### Flexible use and reduced mounting times

The servo drives provides complete control of the dosing pump. Via a defined interface and a corresponding fieldbus option card, it can be easily integrated into the end customer's existing control and fieldbus architecture or can be operated independently without an external controller in cost sensitive applications. In addition to construction time savings thanks to a standardized mechanical solution, the mounting time was reduced by several hours due to pre-mounted and customized components.

# Auger filler for powdery products

## Filling & Dosing



Precise auger filler with servo controller

### Component reduction and modular design

Auger fillers are preferred in applications where precise dosing of powders and granules is essential. A machine manufacturer wishing to create new market potential in the area of semi-automated individual fillers faced the problem that a solution incorporating a servo driven dosing auger and separate PLC was too expensive. They wanted a cost-effective modular solution for semi-automated systems as well as for fully-automated dosing modules requiring integration into filling and flow wrapping machines.

### Decentralized servo drive reduces costs and enhances precision

Thanks to a Parker servo drive solution tailored to the application offering a completely integrated control system meeting the requirements of IEC 61131-3 and PLCopen, it was possible to eliminate external controllers and I/O modules and to reduce total system costs. Furthermore, the process-oriented control integrated into the drive allows for faster response times of the mechanical shutoff slide and thus delivers better precision. running at 80 strokes per minute with a spread reduced by 0.2 g, more than 3300 kg of product can be saved annually over a two shift operation. By connecting

an operating panel to the servo drive, the module can be used as a standalone version. Control via I/O or fieldbus options allows integration into complex machine structures.

### Linear motor for highest performance filling

In automatic high performance filling systems, the mechanical shutoff slide can be optionally replaced by a tubular plug & play linear motor actuator, which allows for more than 90 strokes per minute with high precision and maintenance free operation. Again the servo drive provides the complete control technology, which results in additional savings.

# Capping machine for PET bottles

## Closing & Sealing



PET bottles

### No more hard to open sealing caps!

PET bundles for drinks are very popular. However some retailers complain of loose or incorrectly sealed bottles or sealing caps that were hard to open. The reason can be found in the mechanical sealing heads with a torque coupling. The sealing torques depend on the speed of the filling system, due to the mechanical coupling of the upstream filling system and the capping machine.

### Servo drive solution allows for precise default capping torques and better quality control

In cooperation with a manufacturer of filling and capping systems, Parker developed a complete solution, where each sealing head is controlled by a servo drive. The servo drive not only specifies the default capping torque, but the actual value is also used for continuous quality control. The sealer is mechanically independent of the filling system and is electronically synchronized.

### Format changes at the push of a button

As a positive side effect, package changes to other bottles or lids can be made at the push of a button without additional changeover time. All recipes can be stored in the controller.

In addition to more than 30 servo drives, the cost effective solution offered by Parker included the complete control technology with motion control and operating panel as well as the machine control software. This allowed the machine manufacturer to focus on his core competences and to successfully introduce the new machine into the market.

# Tray sealing machine

## Closing & Sealing



Fresh products in a tray package

### Convenience trends fuel higher output and machine flexibility

Packaging fresh food such as meat products in trays is common and becoming ever more popular in the course of the general convenience food trends. This forces machine manufacturers to continuously increase the output of their machines in order to meet rising demands. At the same time, they have to face the demand for quick product changeover times due to the increased variety of products.

The limiting factor in conventional machines was the execution of linear tool and gripper movements.

### Higher cycle rates thanks to electromechanically operated tools

Parker supported the manufacturer in developing a new machine featuring servo motor driven tools with food grade leadscrew electro thrust cylinders . They allow for high cycle rates and combine high thrust forces with a long lifetime, resulting in reduced service costs. Thanks to the advanced positioning features, the tools can be used more flexibly. In addition to the complete package

including servo drive and controller, the Parker solution can also be easily integrated into other control architectures that may be specified by the machine's end user.

By using standard components, the manufacturer was able to reduce the mechanical construction overhead. The CAD data and dimensioning calculations provided by Parker were also key to this process.

### Higher total plant efficiency due to quicker changeover times

The machine manufacturer's end customers benefit from an 100 % increase in machine output and quick format changes reducing typical changeover times by 10 minutes. An end customer performing 2 format changes per day profits from 100 additional annual production hours, representing a significant increase in his overall equipment effectiveness.

# Horizontal flow wrapping machine

## Form/Fill/Seal



### Cost pressure and falling profits

The flow wrapping machine market is very competitive. A machine manufacturer was facing falling profit margins. At the same time, the request for more flexible machines forced him to develop even more elaborate concepts, increasing design times and costs.

### Optimized complete package solution by Parker

With Parker, the manufacturer found a partner able to offer a complete servo drive and control solution for his horizontal flow wrapper. This cost-effective package comprises a special motion controller, cost optimized servo drives as well as the application software engineering. Technology functions such as empty bag monitoring or program modules for synchronous product infeed are also part of the package.

An electronic line shaft and mechanically independent drives for supply and sealing prevent the sealing jaws from closing and damaging the product if it is not correctly positioned in the foil hose.

### Focusing on core competences

Thus the manufacturer was able to focus on the mechanical construction, to reduce costs. The end customers profit from the flexibility and quick format changes of the completely servo driven machines.



Tubular bags

# Form, fill and seal machine for coffee pads

## Form/Fill/Seal



### Strong demand requires increased product output

Single portion coffee pads represent a convenient alternative to conventional filter coffee and are becoming very popular. As a result of the high demand from the market, coffee producers are on the lookout for even better machines with a higher throughput.

The production process is technically demanding, as the pads must be formed from a strip of fabric, precisely filled, sealed and punched out.

### Parker's solution for highest performance or synchronization demands

A market leading machine manufacturer uses a drive and control solution made by Parker for the development of his high performance machines in order to precisely synchronize up to 25 servo drives via an electronic line shaft. The movements of the individual drives were implemented via powerful electronic camming functions. Auxillary axes are driven via dead time compensated electronic cam switches for maximum performance. Due to Parker's modular architecture, the number of servo driven dosing lanes can be varied to meet

the needs of the customer with optional machine modules.

### 800 Coffee pads per minute

This result is more than impressive: With considerably reduced down times, up to 800 pads per minute, i.e. 48 000 pads per hour can be produced thus ensuring optimum plant efficiency for the end customer.



Machine for forming, filling and sealing single portion coffee pad

# Labeling machine

## Labeling & Decorating



Motors with servo drive on board on the carousel labeling machine

### Customer was looking for a compact design!

On a carousel labeling machine with a large number of axis, the manufacturer has mounted motors with servo drive on board that has led, compared to the previous solution, to substantial savings in time and materials to be realised, while reducing machine footprint.

### Quick and simple machine configuration and reduced wiring

The hybrid cabling solution, which contains all power supply, control and communications signalling offered the

manufacturer a number of benefits including the simplified connections at the motor and a reduction of the wiring time and cost of associated cabling.

### Many advantages, modularity included

Because of the modular nature of Motornet DC, the machine design becomes very easy. The manufacturer can add, following its customer requirements, with very little effort new axis and this simply by duplicating schematic drawings from other axes.

# Carton folding and glueing machine

## Cartoning & Case Packing

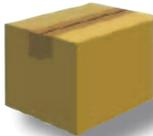

Linear motor driven placing unit of a folding & glueing machine

### Conventional linear drives make the placing unit a bottleneck

A manufacturer of folding carton glueing machines faced the challenge of further increasing the output of his machines. When manufacturing complex folding cartons from several basic cartons, the placing unit which is subject to significant wear represented a bottleneck.

### Linear motor with 2 carriages and harmonized drive technology

Conventional linear drives were insufficient for the simultaneous feed of up to 3 cuts, as the movement was not dynamic enough. Currently available linear motor kits required a prohibitive level of engineering design for the machine manufacturer. Parker was in the position to furnish a ready to mount linear motor module with 2 parallel carriages

simplifying integration into the machine and increasing the achievable output considerably.

### Complete solution increases throughput to 10000 cartons per hour

In addition to the controller including visualization contained in the package, the servo drives optimally suited for linear motor technology were a guarantee for success. Special control algorithms for linear motors and jerk-limited acceleration helped optimize the response behaviour, which in turn increases the cycle rate. The expectations regarding machine output were exceeded thanks to the performance of the new system. The new machine is able to produce up to 10000 cartons per hour. As the linear motor has a non lubricating bearing system, the new solution is also maintenance free.

# Cartoner and case packer

## Cartoning & Case Packing

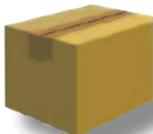

Robot based cartoner and case packer

### Footprint was to be reduced

The customers of a cartoner and case packer manufacturer requested a more economical solution requiring less floor space. Previous systems consisted of a complex packaging line rather than individual machines occupying substantially more space. Furthermore, they faced many downtime issues due to jammed cartons caused by problems with the air cylinders used in the machine.

### System solution integrates robotics and motion control

In cooperation with Parker, the manufacturer developed a new generation of case packers, where a Scara robot performs all relevant tasks such as erecting and positioning the carton, filling,

closing and palletizing. Parker not only provided the drive and control technology, but also supported the machine manufacturer with application support and integration of the robot, which is directly driven by the Parker motion controller.

### One of the most compact secondary packaging machines on the market

With reference to compactness and flexibility, the machine is among the best on the market.

The consistent use of servo technology instead of traditional drives helped minimize product jams. Increased flexibility with reference to usable format width has proven to be a positive side effect of the servo technology.

# Sync gates in bottle handling systems

## Palletizing



Sync gate for bottle transporting system

### A continuous product stream must be divided into several lanes

In many filling systems, one of the challenges frequently faced by manufacturers is the need to separate a single lane continuous product stream of bottles into several lanes in order to bundle them for palletizing.

The main issue is that the bottles require careful handling at high speeds with high dynamic response. The limited stroke length of the linear actuators regularly used in these applications also limits the flexibility of the machine.

### Standard linear actuator drives distributor lid

Parker worked in partnership with a manufacturer of conveyor systems for bottles and pallets to create a sync gate where the distribution of the product stream takes place via a two axis system with one axis placed orthogonally to the travel direction and a linear drive parallel to the conveyor. A ready-to-mount standard linear actuator with toothed belt was used for this purpose. At the time

of distribution, the linear actuator moves synchronously to the conveyor speed. The distributor lid is mounted on the linear actuator. The actuator is first synchronized to the conveyor speed in order to split the product stream and then moves orthogonally to the conveyor direction. After completion of the cross movement, the linear actuator returns to its original position.

### Servo drives with technology functions for reduced engineering overhead

In addition to the linear actuator, the Parker kit also comprised 2 servo drives and a complete software technology package. The servo drives can be integrated via a communication bus option to all common control environments. Thanks to the complete application solution offered by Parker, it was possible to bring the machine to market with minimized engineering overhead.

# Turnkey palletizing robots as a complete system

## Palletizing



Parker turnkey palletizing system

### Rising demand for complete packaging lines

In addition to components, application solutions and sub systems, Parker also offers turnkey automation systems, in particular palletizing robots. These are not only of interest to end users in the pharmaceuticals and food processing industries, but also for machine manufacturers wishing to complement their product portfolio in order to offer turnkey packaging lines where the end customer doesn't want to make time and cost intensive integration or customization changes, which is a common demand packaging machine manufacturers have to face.

### Turnkey palletizing system for case packer manufacturers

Parker's linear actuator guiding systems are lubricant free and feature optimal hygienic properties thanks to their lifetime lubricated bearings. Parker succeeded, for instance, in providing a turnkey palletizing system to a manufacturer of pharmaceutical packaging machines. This system features a multi function gripper with rotary module which bundles the secondary packages coming out of the

case packer into a buffer area to form a stack following a defined pattern. At the same time, the multi function gripper ensures the feeding of new folding cartons into the case packer.

### Minimum footprint and short time to market

As the end user's factory building has a clearance height of only 4.5 m, a special telescopic linear actuator provided the ideal solution. The result was a compact packaging line with a minimal footprint. The machine manufacturer was able to deliver a packaging line within the shortest possible time to market to its customer, who is highly satisfied with the system and has already ordered additional lines.

# Parker Worldwide

## Europe, Middle East, Africa

**AE – United Arab Emirates,**  
Dubai

Tel: +971 4 8127100  
parker.me@parker.com

**AT – Austria,** Wiener Neustadt

Tel: +43 (0)2622 23501-0  
parker.austria@parker.com

**AT – Eastern Europe,** Wiener  
Neustadt

Tel: +43 (0)2622 23501 900  
parker.easteurope@parker.com

**AZ – Azerbaijan,** Baku

Tel: +994 50 2233 458  
parker.azerbaijan@parker.com

**BE/LU – Belgium,** Nivelles

Tel: +32 (0)67 280 900  
parker.belgium@parker.com

**BY – Belarus,** Minsk

Tel: +375 17 209 9399  
parker.belarus@parker.com

**CH – Switzerland,** Etoy

Tel: +41 (0)21 821 87 00  
parker.switzerland@parker.com

**CZ – Czech Republic,** Klecany

Tel: +420 284 083 111  
parker.czechrepublic@parker.com

**DE – Germany,** Kaarst

Tel: +49 (0)2131 4016 0  
parker.germany@parker.com

**DK – Denmark,** Ballerup

Tel: +45 43 56 04 00  
parker.denmark@parker.com

**ES – Spain,** Madrid

Tel: +34 902 330 001  
parker.spain@parker.com

**FI – Finland,** Vantaa

Tel: +358 (0)20 753 2500  
parker.finland@parker.com

**FR – France,** Contamine s/Arve

Tel: +33 (0)4 50 25 80 25  
parker.france@parker.com

**GR – Greece,** Athens

Tel: +30 210 933 6450  
parker.greece@parker.com

**HU – Hungary,** Budapest

Tel: +36 1 220 4155  
parker.hungary@parker.com

**IE – Ireland,** Dublin

Tel: +353 (0)1 466 6370  
parker.ireland@parker.com

**IT – Italy,** Corsico (MI)

Tel: +39 02 45 19 21  
parker.italy@parker.com

**KZ – Kazakhstan,** Almaty

Tel: +7 7272 505 800  
parker.easteurope@parker.com

**NL – The Netherlands,** Oldenzaal

Tel: +31 (0)541 585 000  
parker.nl@parker.com

**NO – Norway,** Asker

Tel: +47 66 75 34 00  
parker.norway@parker.com

**PL – Poland,** Warsaw

Tel: +48 (0)22 573 24 00  
parker.poland@parker.com

**PT – Portugal,** Leca da Palmeira

Tel: +351 22 999 7360  
parker.portugal@parker.com

**RO – Romania,** Bucharest

Tel: +40 21 252 1382  
parker.romania@parker.com

**RU – Russia,** Moscow

Tel: +7 495 645-2156  
parker.russia@parker.com

**SE – Sweden,** Spånga

Tel: +46 (0)8 59 79 50 00  
parker.sweden@parker.com

**SK – Slovakia,** Banská Bystrica

Tel: +421 484 162 252  
parker.slovakia@parker.com

**SL – Slovenia,** Novo Mesto

Tel: +386 7 337 6650  
parker.slovenia@parker.com

**TR – Turkey,** Istanbul

Tel: +90 216 4997081  
parker.turkey@parker.com

**UA – Ukraine,** Kiev

Tel +380 44 494 2731  
parker.ukraine@parker.com

**UK – United Kingdom,** Warwick

Tel: +44 (0)1926 317 878  
parker.uk@parker.com

**ZA – South Africa,** Kempton Park

Tel: +27 (0)11 961 0700  
parker.southafrica@parker.com

## North America

**CA – Canada,** Milton, Ontario

Tel: +1 905 693 3000

**US – USA,** Cleveland

Tel: +1 216 896 3000

## Asia Pacific

**AU – Australia,** Castle Hill

Tel: +61 (0)2-9634 7777

**CN – China,** Shanghai

Tel: +86 21 2899 5000

**HK – Hong Kong**

Tel: +852 2428 8008

**IN – India,** Mumbai

Tel: +91 22 6513 7081-85

**JP – Japan,** Tokyo

Tel: +81 (0)3 6408 3901

**KR – South Korea,** Seoul

Tel: +82 2 559 0400

**MY – Malaysia,** Shah Alam

Tel: +60 3 7849 0800

**NZ – New Zealand,** Mt Wellington

Tel: +64 9 574 1744

**SG – Singapore**

Tel: +65 6887 6300

**TH – Thailand,** Bangkok

Tel: +662 186 7000-99

**TW – Taiwan,** Taipei

Tel: +886 2 2298 8987

## South America

**AR – Argentina,** Buenos Aires

Tel: +54 3327 44 4129

**BR – Brazil,** Sao Jose dos Campos

Tel: +55 800 727 5374

**CL – Chile,** Santiago

Tel: +56 2 623 1216

**MX – Mexico,** Apodaca

Tel: +52 81 8156 6000

We reserve the right to make technical changes. The data correspond to the technical state at the time of printing.  
© 2012 Parker Hannifin Corporation.  
All rights reserved.

192-490100N3

February 2012



### EMEA Product Information Centre

Free phone: 00 800 27 27 5374

(from AT, BE, CH, CZ, DE, DK, EE, ES, FI, FR, IE, IL, IS, IT, LU, MT, NL, NO, PL, PT, RU, SE, SK, UK, ZA)

US Product Information Centre

Toll-free number: 1-800-27 27 537

www.parker.com

Your local authorized Parker distributor