

# PA2 PowerStation Family

The Power of Interact HMI  
In an Affordable Package

**New  
No-Display  
System**

The new PA2 family of PowerStations is CTC-designed and manufactured to be an economical push button panel replacement solution with the option to include advanced software features.

Including no-display option, 6", 8", 10.4" and 15" color touchscreen displays, all units combine the connectivity, functionality and expandability of Interact HMI software with standard hardware features such as TFT displays, CompactFlash storage, RS-232, RS-422/485 and 100BaseT Ethernet ports. The PA2 family has been designed as a direct drop in replacement for our popular PA family of PowerStations. The PA2 offers new higher performance processors and TFT displays in all sizes.



## Contact Information:

Parker Hannifin Corporation  
**Electromechanical Automation Division**  
5500 Business Park Drive  
Rohnert Park, CA 94928  
phone 800.358.9068  
[www.parkermotion.com/HMI](http://www.parkermotion.com/HMI)

## PA2 Functionality

- **CTC-designed and manufactured for reliability with consistent hardware features for all units**
- **Feature-rich with Interact Panel Tools, Graphics, Alarming and Networking software features**
- **Expandable with optional Interact software modules such as Historical Trending and advanced recipe management**
- **Flexible connectivity including 60+ communication drivers - including Ethernet drivers**
- **Designed for easy "drop-in" replacement of our PA family PowerStations and many other popular operator panels**

## PA2 Features

- **No-Display, 6", 8", 10.4" and 15" Touchscreen Displays**
- **CompactFlash and 100-Base-T Ethernet**
- **Interact HMI Software with advanced module support**
- **Multiple control device connectivity**
- **Slim profile with consistent features**
- **Quick and easy clip mounting**
- **Type 4/4X rating**



ENGINEERING YOUR SUCCESS.

# PA2 Specifications

## PA2 Model Number Configurations

Model	Description
<b>PA200V-133</b>	PA2 system with no display
<b>PA206Q-133</b>	PA2 with 6" TFT display, 320 x 240 Resolution
<b>PA206V-133</b>	PA2 with 6" TFT display, 640 x 480 Resolution
<b>PA208T-133</b>	PA2 with 8" TFT display, 640 x 480 Resolution
<b>PA210T-133</b>	PA2 with 10.4" TFT display, 640 x 480 Resolution
<b>PA215T-133</b>	PA2 with 15" TFT display, 1024 x 768 Native Resolution

All PA2 models include an AMD LX700 CPU (433 MHz), 512MB (Min.) Compact Flash card, UL/CUL and CE Agency approvals.

Class 1 Division 2 Agency approvals are available at extra cost, The last digit of the model number changes from 3 to 5 on Class 1 Division 2 approved products.



## Specifications

Features	PA200	PA206Q/PA206V	PA208	PA210	PA215
<b>Size</b>		6" Color TFT 5.7" Diagonal	8" Color TFT 7.5" Diagonal	10" Color TFT 10.4" Diagonal	15" Color TFT 15" Diagonal
<b>Resolution</b>	PA200 has no display, but is pre-configured with a standard VGA output.	1/4 VGA (320 X 240), Optional VGA (640x480)	VGA (640 X480)	VGA (640 x 480)	XGA (1024 x 768)
<b>Viewing Angle</b>		±70° L/R 70° U, 50° D ±80° L/R 80° U, 70° D	±70° L/R 60° U, 65° D	±70° L/R 50° U, 60° D	±80° L/R 80° U, 60° D
<b>Brightness</b>	Can be used with our PHM Family monitors to create a "split" system	QVGA - 470 NIT VGA - 350 NIT	400 NIT	200 NIT	250 NIT
<b>Bulb Life (hrs)</b>		75,000	50,000	50,000	40,000
<b>Weight (lbs)</b>	2.0	2.56	4.1	8.4	13.8
<b>Dimensions Inches (HxWxD)</b>	6.05 x 4.12 x 2.52	6.00 x 7.40 x 2.99	7.60 x 10.20 x 3.06	11.00 x 13.78 x 4.01	13.30 x 16.80 x 5.19
<b>Interface</b>	Analog Resistive Touchscreen				
<b>Power Requirement</b>	12/24VDC @ 18W (Range: min 11 VDC, 28 VDC Max)		24 VDC @ 22W (Range: min 18 VDC, 28 VDC max)		
<b>HMI Software</b>	Interact Runtime included (PTM, GMM, AMM and NET)				
<b>Processor</b>	AMD LX700 [433 MHz]				
<b>CompactFlash Storage</b>	Minimum 512MB Compact Flash External				
<b>Ports</b>	<b>Keyboard</b>	USB 2.0			
	<b>Mouse</b>	USB 2.0			
	<b>USB*</b>	(2) USB 2.0, Type A*			
	<b>Serial</b>	(1) RS-232, (1) RS-232/422/485			
	<b>Ethernet</b>	(1) 10/100Base-T w/ RJ45			
<b>Environment</b>	<b>Temperature</b>	0 - 50°C			
	<b>Rel. Humidity</b>	5-95% (non-condensing)			
	<b>Vibration</b>	10-500 Hz 2grms (Random)			
	<b>Shock</b>	10G, 11 msec (operating); 30G, 11 msec (non-operating)			
<b>Agency Approval</b>	CE; UL/CUL, NEMA 4/4X; Class 1 Div. 2 (Available as an option)				

\*Note: (USB Ports are not accessible from Interact)

All published product specifications are subject to change without notice.

# Cutout Dimensions

## PA200

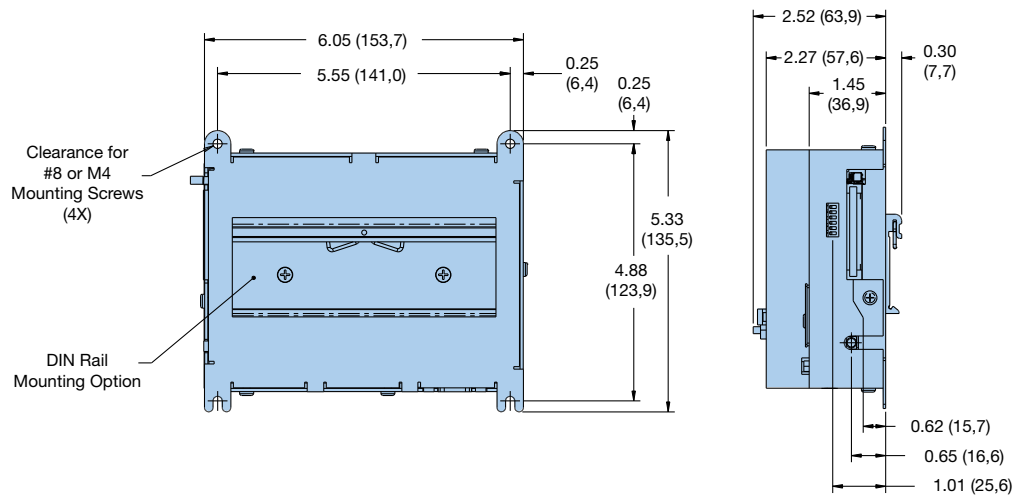

## PA206

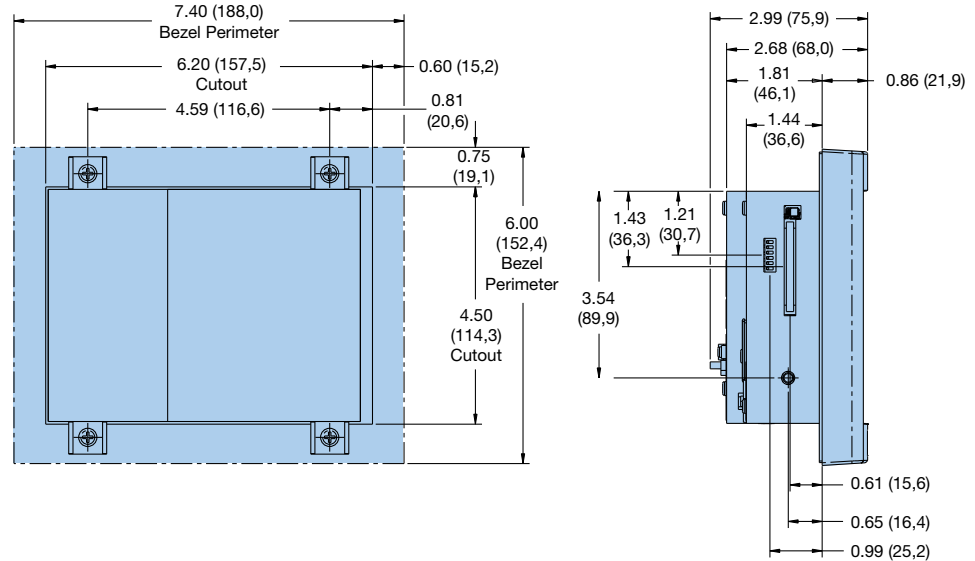

## PA208

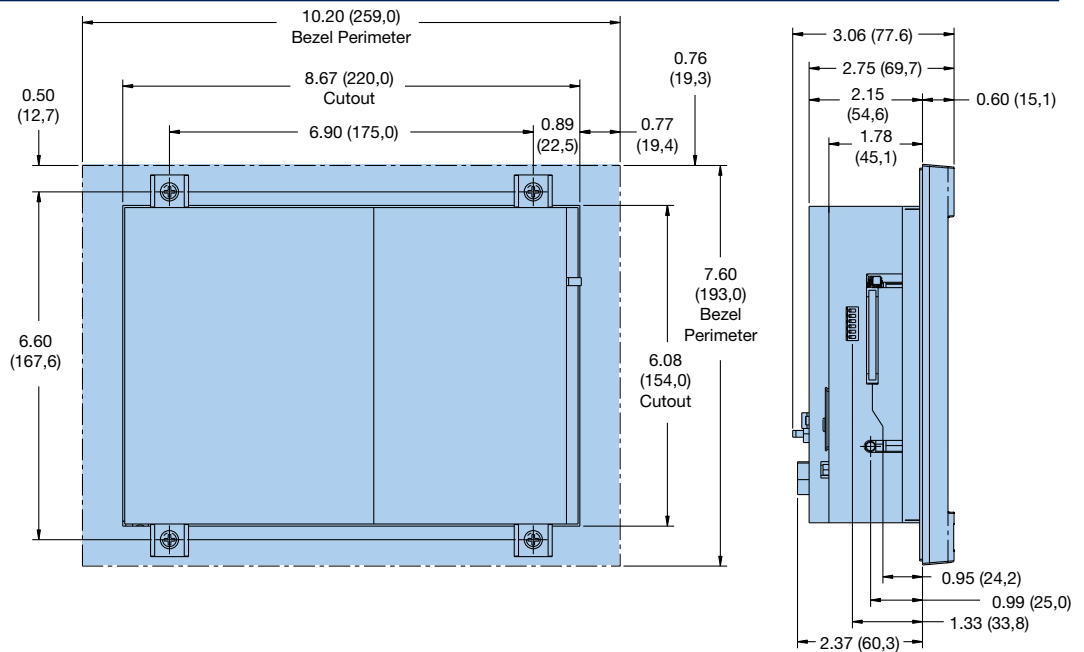

# Cutout Dimensions

## PA210

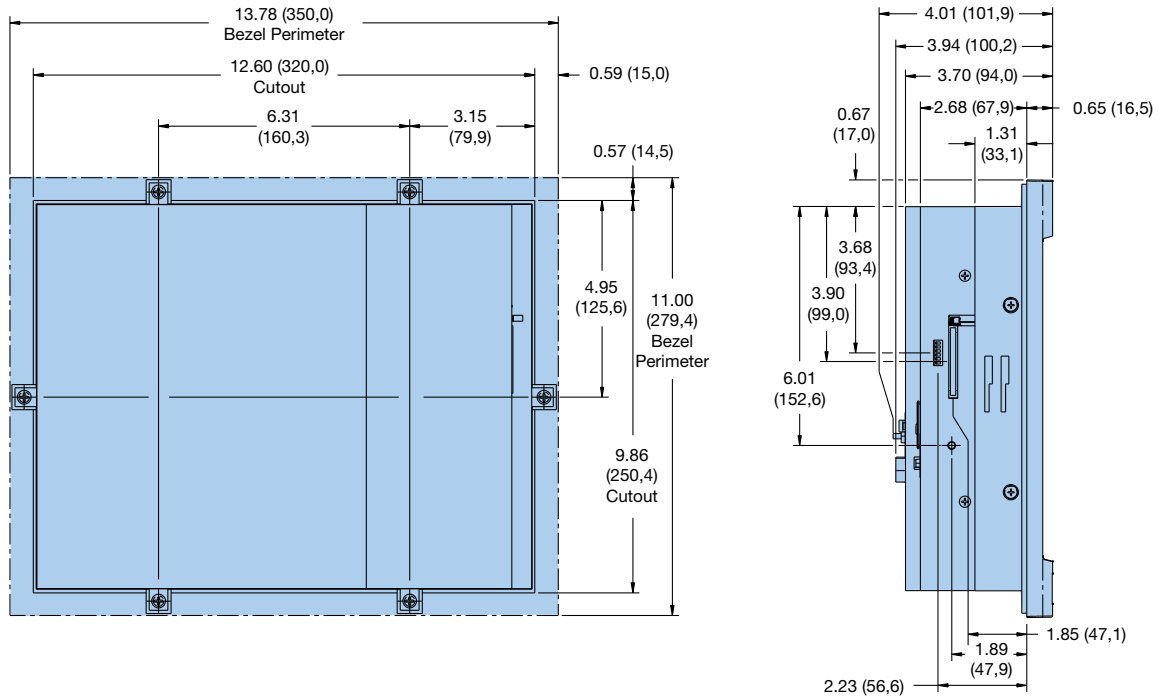

## PA215

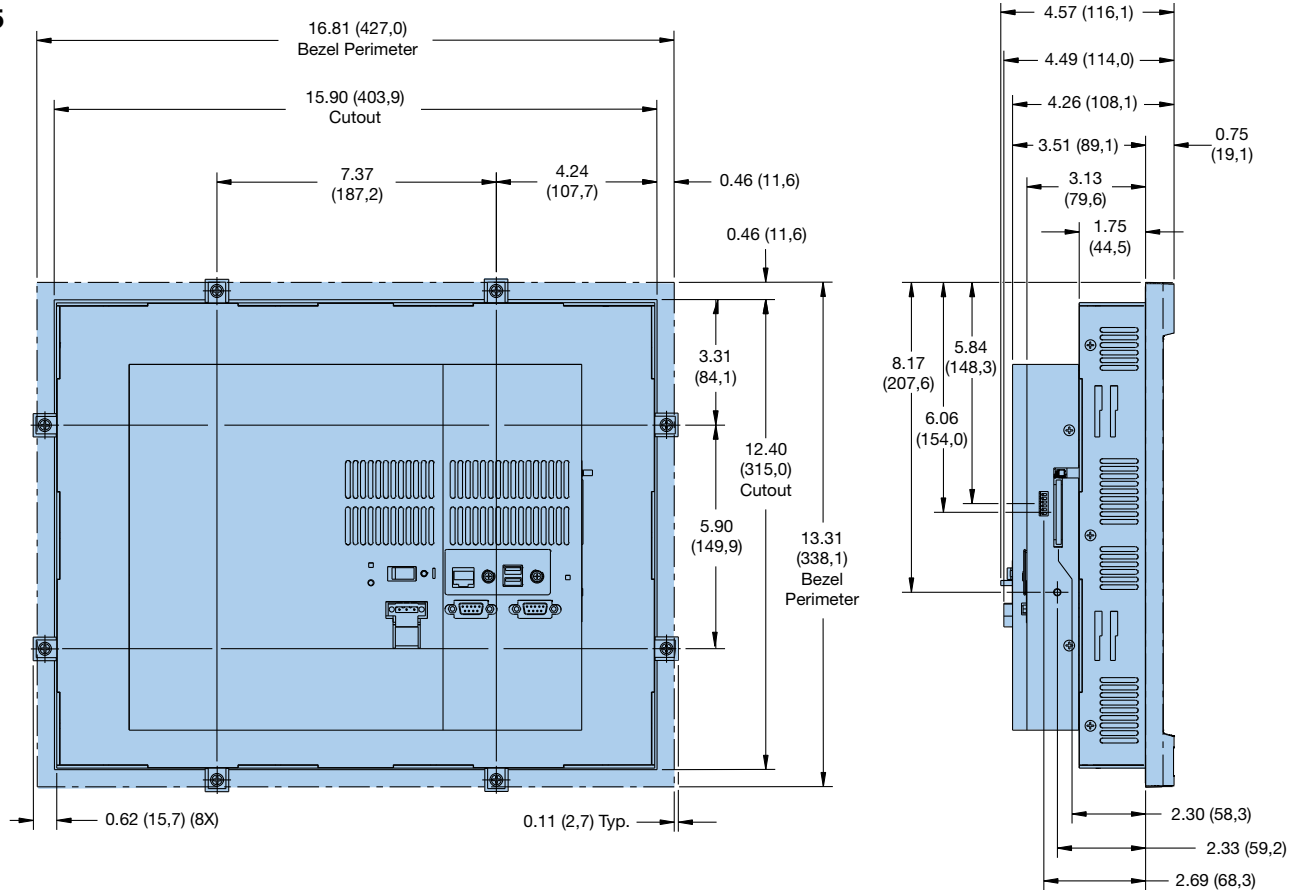

ENGINEERING YOUR SUCCESS.