

# ***P1-10" PENTIUM POWERSTATION***

## **User Guide**

***CTC Parker Automation  
50 W. TechneCenter Drive, Milford, Ohio 45150***

***Phone: 513-831-2340  
Technical Support: 513-248-1714***

## Copyright and Trademark Notice

Copyright © 2002 by CTC Parker Automation. All rights reserved. No part of this publication may be reproduced, transmitted, transcribed, stored in a retrieval system, in any form or by any means, mechanical, photocopying, recording or otherwise, without the prior written consent of CTC Parker Automation.

While every precaution has been taken in preparing this manual, CTC Parker Automation and the author assume no responsibility for errors or omissions. Neither is any liability assumed for damages resulting from the use of the information contained herein. All product and company names are trademarks of their respective companies and licenses.

## Product Warranty Information

CTC Parker Automation provides top quality products through rigid testing and the highest quality control standards. However, should a problem occur with your hardware or with the software protection key, our standard product warranty covers these items for 15 months from the date of shipment. Exceptions appear below:

- Backlight bulbs have a 90-day warranty.
- Third-party products, such as bus cards, carry the manufacturer's specified warranty.
- For all displays, image retention (burn-in) is not covered by warranty.
- Software revisions that occur within 60 days after purchase are available under warranty, upon request. Please review the software License Agreement for additional software warranty information.

If you have any questions about your application or need technical assistance, please check the Support page on the CTC website [www.ctcusa.com](http://www.ctcusa.com) or call Technical Support at 513-248-1714, 8:00 a.m. to 5:00 p.m. Eastern Time. You may call this same number after hours for emergency assistance. See ***Customer Support Services*** on page 10 for more information about our support products and services.

# Table of Contents

<b>Chapter 1: Overview and Support Services</b> .....	<b>7</b>
What's in this User Guide? .....	8
Documentation Standards .....	9
Text Conventions .....	9
ISO Symbols .....	9
Customer Support Services .....	10
Technical Support .....	10
Training and New Business Development.....	11
Product Support Program .....	12
Documentation.....	12
<b>Chapter 2: Introducing the P1-10" PowerStation</b> .....	<b>14</b>
Hardware Overview .....	15
Software Overview.....	16
CPU Card .....	17
BIOS .....	18
Displays .....	18
CompactFlash Slot .....	19
Ports .....	21
Serial Ports .....	21
COM1, 2, and 3 Pinouts.....	22
Parallel Port .....	23
PS/2 Ports.....	24
Ethernet Port.....	24
Power Supply.....	24
Battery.....	25
Fuse .....	25
System Peripheral Devices.....	26
Watchdog Timer.....	26
PowerSmart .....	26
Expansion Slots .....	27
I/O Addresses .....	27
IRQs.....	28
Memory.....	29

Memory Modules .....	29
Memory Map.....	29
Memory Guidelines .....	29
<b>Chapter 3: Installation.....</b>	<b>30</b>
Selecting a Location.....	31
Class I, Division 2 Guidelines.....	31
Environmental Guidelines .....	31
Electrical Guidelines.....	31
Temperature Guidelines.....	32
Enclosure Guidelines .....	32
Accessing Ports, Drives, and Other Controls.....	32
Mounting the System .....	33
Starting the System.....	34
<b>Chapter 4: Maintenance .....</b>	<b>37</b>
BIOS Setup .....	38
Configuring Serial Ports .....	38
Loading Default BIOS Settings.....	39
Removing the CTC Splash Screen .....	39
Reinstalling the PowerStation Utilities.....	40
Restoring a CompactFlash Card.....	40
Installing PowerSmart for MS-DOS.....	41
Maintaining the Display .....	42
Cleaning the Display Screen .....	42
Reconfiguring the Touchscreen Driver.....	43
Recalibrating the Touchscreen.....	44
Performing Internal Maintenance .....	46
Replacing Components .....	46
Observing ESD Precautions.....	47
Opening and Closing the System.....	47
Changing Jumper Settings .....	50
<b>Chapter 5: Troubleshooting .....</b>	<b>55</b>
Troubleshooting Instructions .....	56
Problems When Starting .....	57
System does not start; the display is blank.....	57
The RAM test fails, or the total memory installed does not match the total contiguous RAM listed in the display following the RAM test .....	58
The system locks up while starting and will not restart .....	58

The DOS prompt is displayed instead of the MachineShop Shell main menu.....	59
<b>Problems Signaled by PowerSmart .....</b>	<b>60</b>
An error condition exists for a power supply voltage.....	60
An error condition exists for a temperature.....	60
PowerSmart indicates a COMM ERROR .....	61
<b>Problems with Displays.....</b>	<b>62</b>
The top or bottom half of the screen looks dark .....	62
After startup, the display is blank.....	62
<b>Problems with Touchscreens.....</b>	<b>63</b>
After startup, the touchscreen does not work properly, the touchscreen does not load, or touchscreen calibration is incorrect .....	63
After calibrating the touchscreen, the touchscreen doesn't work or doesn't follow your finger.....	63
<b>Problems with Peripheral Devices .....</b>	<b>64</b>
A PS/2 mouse does not work .....	64
A keyboard does not work .....	64
The Ethernet port does not work .....	64
<b>Problems with the Autoexec.bat or Config.sys file .....</b>	<b>65</b>
Determining system requirements .....	65
Overwriting a corrupted file.....	65
Modifying an existing file.....	65
Verifying the Autoexec.bat file .....	66
<b>Appendix A: Specifications.....</b>	<b>67</b>
Physical Specifications .....	68
Recommended SDRAM Manufacturers.....	69
Operating Systems Supported.....	69
Display Specifications .....	70
Environmental Specifications.....	71
Electrical Specifications .....	72
Testing Specifications .....	72
Faceplate Chemical Resistance .....	73
Agency Approvals.....	74
<b>Appendix B: Dimensional Drawings.....</b>	<b>75</b>
Model: P1-10" .....	76
Front View: Monitor.....	76
Left Side View: Components .....	77
Back View: Components.....	78

Cutout .....	79
<b>Index .....</b>	<b>80</b>

# CHAPTER 1: OVERVIEW AND SUPPORT SERVICES

This chapter explains what is in this User Guide. It also describes the documentation standards used in the Guide and important customer support services.

## Chapter Contents

---

<i>What's in this User Guide?</i> .....	8
<i>Documentation Standards</i> .....	9
<i>Customer Support Services</i> .....	10
<i>Documentation</i> .....	12

## What's in this User Guide?

This Guide describes the model P1-10" PowerStation from CTC Parker Automation.

The purpose of this Guide is to help you set up and use your PowerStation model P1-10". It describes your system and explains how to install your system, how to maintain it in good condition, and how to solve common operating problems.

In this Guide, you will find the following chapters:

<b>Chapter</b>	<b>Title</b>	<b>Contents</b>	<b>Pg</b>
1	<i>Overview and Support Services</i>	Overview of this Guide's contents, and CTC customer support services.	7
2	<i>Introducing the P1-10" PowerStation</i>	System functions and features, including cabling, pinout, and addressing information.	14
3	<i>Installation</i>	How to mount your system in an enclosure or on a panel and start it up.	30
4	<i>Maintenance and Troubleshooting</i>	How to maintain the system.	37
5	<i>Troubleshooting</i>	How to solve operational problems.	55
Appendix A	<i>Specifications</i>	Tables showing system specifications.	65
Appendix B	<i>Dimensional Drawings</i>	Complete dimensional drawings, including cutout and mounting diagrams, for the model P1-10" PowerStation.	75





## Documentation Standards

This Guide uses the following standards.

### Text Conventions

Style	Type of Text
<b>Bold</b>	Names of buttons, tabs, menus, menu items, commands, files, keyboard keys, dialog boxes, and other important terms.
<b><i>Bold Italics</i></b>	Titles of User Guides, chapters, or sections, and linked cross-references.
Courier font	Text to be entered from a keyboard.
▶	Next step in a software path. For example, "In the Windows task bar, click <b>Start ▶ Settings ▶ Control Panel.</b> "
+	Indicates two or more keyboard keys that must be pressed simultaneously. For example, <b>Ctrl+Alt+Delete.</b>
<b>Note</b>	Alternative approaches or issues.
<b>Important</b>	Information that will save time and minimize problems.
<b>Warning</b>	Information that will prevent equipment damage or personal injury.

### ISO Symbols

Symbol	Meaning
	International Standards Organization (ISO) symbol for Caution (ISO 3864 No. B.3.1). Failure to follow instructions could affect operation of the computer.
	ISO symbol for Caution—risk of electrical shock (ISO 3864 No B.3.6). Failure to follow instructions could cause personal injury from electrical shock or damage to equipment.

## Customer Support Services

We welcome your thoughts and suggestions on our products and services. You can contact us by telephone, email, or fax. You can also visit CTC Parker Automation on the World Wide Web to learn the latest about our hardware, software, and customer support services.

Customer Support	
Telephone	513-831-2340
Technical Support	513-248-1714
Fax	513-831-5042
E-mail	<a href="mailto:sales@ctcusa.com">sales@ctcusa.com</a>
	<a href="mailto:support@ctcusa.com">support@ctcusa.com</a>
	<a href="mailto:DocComments@ctcusa.com">DocComments@ctcusa.com</a>
World Wide Web	<a href="http://www.ctcusa.com">www.ctcusa.com</a>

We recognize that every customer and every application has different support needs. To meet these needs, we offer four types of customer support services:

- Technical Support
- Training and New Business Development
- Product Support Program
- Documentation

### Technical Support

The Technical Support department welcomes your questions as you develop or run your applications. We offer complimentary support for any customer, whether you are an end-user, original equipment manufacturer (OEM), system integrator, or distributor.

If you have a question about your system,

- Check any release notes shipped with the system.
- Consult the documentation and other printed materials shipped with your system.
- Review Chapter 4: Maintenance and Chapter 5: Troubleshooting, in this Guide.

If you cannot find a solution using one of the preceding sources,

- Call your CTC products distributor for support.
- View the Technical Support web page at [www.ctcusa.com](http://www.ctcusa.com) which contains answers to Frequently Asked Questions, application notes, product user guides, and software downloads that may be helpful.
- Call CTC Technical Support at 513-248-1714, 8:00 a.m. to 5:00 p.m., Eastern Time.

You can call CTC Technical Support after hours for emergency assistance.

## Training and New Business Development

Our Training and New Business Development department provides service in two areas: training and consulting.

### Training

We offer training on all of our products either at CTC Parker Automation, in our state-of-the-art training center, or at your site. You can learn how to do the following:

- Write custom interfaces
- Develop specialized applications
- Implement your complete operator interface application

To contact the Training Coordinator, see the table below:

Training	
Telephone	1-800-233-3329
E-mail	<a href="mailto:training@ctcusa.com">training@ctcusa.com</a>

### Application Engineering Services

We offer consulting services through our Application Engineering Services group where we can build your application from the ground up. The following are just a couple of the services they can perform:

- Write custom communications drivers
- Design special modules to perform functions unique to your application

Our specialists are flexible; they can create a project development schedule that meets your needs. You can contact Application Engineering Services in one of the following ways:

Application Engineering	
Telephone	1-800-233-3329
E-mail	<a href="mailto:appeng@ctcusa.com">appeng@ctcusa.com</a>

## Product Support Program

The Product Support Program (PSP) is designed to keep you up-to-date with the current versions of CTC Parker software. PSP is an easy, cost-effective way to receive the most recent CTC software and associated utilities. PSP consists of a renewable, one-year membership that provides you with the following:

- Free upgrades and utilities
- E-mail notification of software updates
- Valuable tools for MachineShop, Interact, and MachineLogic

Single-user, multi-user, and corporate licenses are available. To learn more about PSP, contact us in one of the following ways:

Product Support	
Telephone	1-800-233-3329
E-mail	<a href="mailto:sales@ctcusa.com">sales@ctcusa.com</a>

## Documentation

You can download CTC product documentation from our website at [www.ctcusa.com](http://www.ctcusa.com) under Support/Product Manuals.

We also welcome your comments on this User Guide or any of our other documentation. Please email your comments to: [DocComments@ctcusa.com](mailto:DocComments@ctcusa.com)



# CHAPTER 2: INTRODUCING THE P1-10" POWERSTATION

This chapter describes the features of the P1-10" PowerStation including the display options, drives, and ports that link the system with other devices. It also describes system peripheral devices and the systems' expansion slots, I/O addresses, and memory.

## Chapter Contents

---

<i>Hardware Overview</i> .....	15
<i>Software Overview</i> .....	16
<i>CPU Card</i> .....	17
<i>BIOS</i> .....	18
<i>Displays</i> .....	18
<i>CompactFlash Slot</i> .....	19
<i>Ports</i> .....	21
<i>System Peripheral Devices</i> .....	26
<i>Expansion Slots</i> .....	27
<i>I/O Addresses</i> .....	27
<i>IRQs</i> .....	28
<i>Memory</i> .....	29

## Hardware Overview

The P1-10" PowerStation has the following features:

- 10" Touchscreen display
- External CompactFlash (CF) slot
- Three external serial ports (COM1, COM2, COM3)
- Parallel port
- Ethernet port
- Watchdog Timer
- PowerSmart system monitor

---

**Note** For additional information about these systems and their displays, see the following:  
*Display Specifications* on page 70, and *Physical Specifications* on page 68.

---

## Software Overview

Each P1-10" PowerStation comes with one external CompactFlash card that is pre-loaded with the operating system and all PowerStation utilities, including the MachineShop Shell. Backup copies of all installed software are provided on CD.

The following table shows the software you will receive with your system. Descriptions of the software follow the table.

P1 PowerStation Family Documentation CD	DOS	Windows		
		98	2000	NT
Flashback		X	X	X
PowerSmart	X			
MachineShop Toolbar		X	X	X

- **Flashback:** a utility that allows you to restore all system software to an external CompactFlash card.
- **PowerSmart:** a utility that allows you to continuously monitor the system's conditions.
- **MachineShop Toolbar:** a program that provides a simple user interface for managing a machine profile or project. The MachineShop Toolbar allows you to download Interact projects from your development PC to your runtime PowerStation system.



## CPU Card

The CPU card in the model P1-10" PowerStation uses a custom, small format form-factor. The CPU card has the following characteristics:

Feature	Description
Size (H x W)	8.0" (203.2mm) x 10.65" (270.5mm)
Processor	Intel® Pentium 166MHz Tillamook
Bus interfaces	<ul style="list-style-type: none"> <li>• ISA bus: 16-bit, 8MHz</li> <li>• PCI bus: 32-bit, 33MHz</li> </ul>
Configurable jumpers	<ul style="list-style-type: none"> <li>• COM2</li> <li>• Ethernet port</li> <li>• CF master/slave (jumpers for external CF)</li> <li>• CMOS jumper</li> <li>• Video</li> </ul>

The following illustration shows the CPU card and its major features:

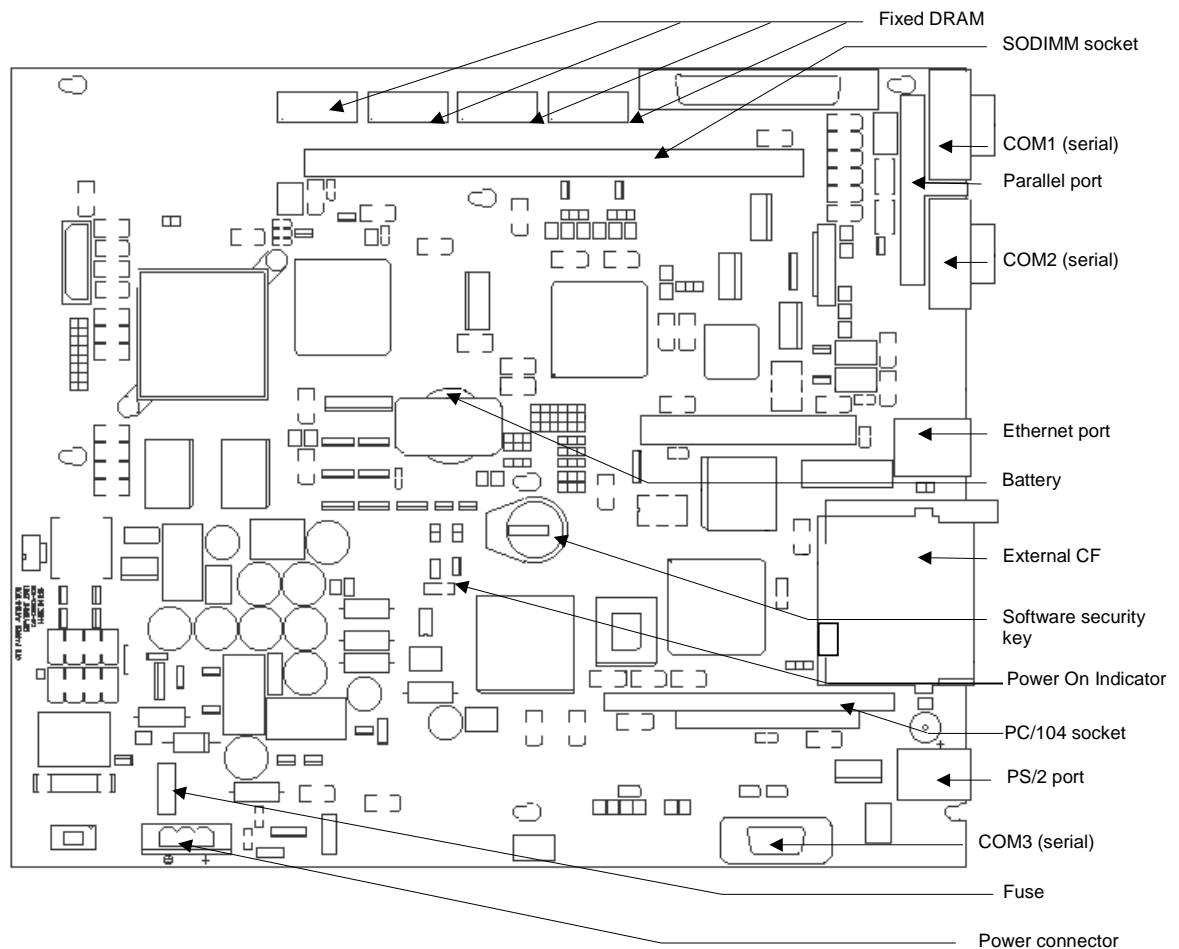

**Note** To see the locations of the workstation's configurable jumpers, see *Jumper Locations* on page 50.

## BIOS

The P1-10" PowerStation uses a Phoenix Basic Input Output System (BIOS), with 256K FLASH memory. The system BIOS performs two functions:

- It performs initialization tasks (testing and configuration of the system's standard components—e.g., video, system board RAM, serial and parallel ports, and other I/O devices) during its Power-on Self Test (POST).
- It provides application programs with a hardware-dependent software interface to system devices.

Standard BIOS features include the following:

- FLASH/EPROM-based setup utility
- POST
- Password protection
- System plug and play support
- Advanced power management

In addition, the system BIOS features provide the following functionality:

- A Load Setup Defaults feature allows you to re-establish the BIOS default settings if necessary.
- The BIOS CMOS setup allows you to select I/O resources for the serial ports, touchscreen, and parallel port through menus.
- The jumpers select video BIOS support for each supported flat panel display, as well as for a CRT-only mode. These jumpers connect to I/O pins on the video controller; then, the BIOS reads these connections at startup.
- The BIOS supports a startup splash screen that displays the CTC Parker logo. You can enable or disable this screen through a menu selection in the CMOS setup.

---

**Note** For additional information about the system BIOS, see *BIOS Setup* on page 38.

---

## Displays

The P1-10" PowerStation supports the displays shown in the following table:

PowerStation	Size	Resolution	Color	Type
P1-10"	9.4"	VGA	Mono	STN
	10.4"	VGA	Color	TFT
	10.4"	VGA	Bright Color	TFT

---

**Note** For additional display information, see also *Display Specifications* on page 70.

---

## CompactFlash Slot

Instead of an internal hard drive, the P1-10" PowerStation has one external CompactFlash (CF) slot to accommodate CF cards. A CF card is like a removable hard drive and provides non-volatile storage memory. A CF card is often used as a replacement for a hard drive because a CF card is well suited to environments in which the unit may be vibrated or shaken. You can store system files, programs, projects, and applications on one or more CF cards.

The external CF slot supports Type 1 or Type 2 CF cards. It is located at the left side of the unit, as shown in the following illustration. The external CF is designated as the secondary master drive in the BIOS settings.

The following illustration shows the location of the CF Slot on a P1-10".

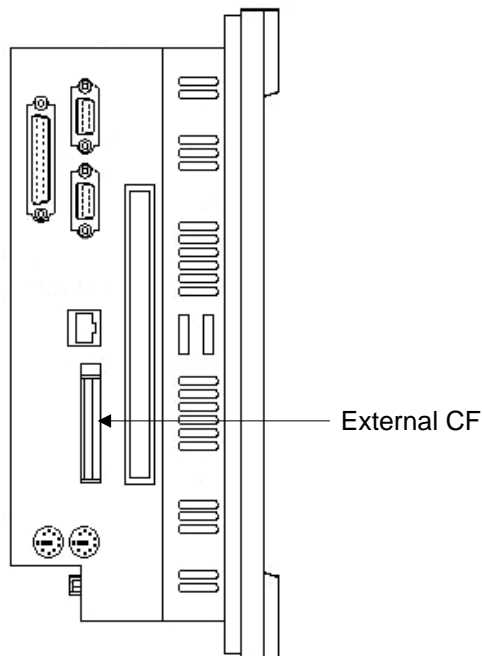

## Using CompactFlash Cards

You can reformat a CF card or update the files on it. See *Restoring a CompactFlash Card* on page 41 for complete instructions.

---

**Important** Formatting a CompactFlash Card in Windows NT and 2000 overwrites the systems files that make the flashcard bootable.

---

Uses for the External CF card are as follows:
Operating system
Programs
Projects and applications
Runtime software

If you purchased a CF card, we recommend that you purchase at least one additional card to serve as a backup. You may wish to have several cards on hand to store different projects. To purchase additional CF cards, call your local distributor.

## Removing and Replacing CompactFlash Cards

To remove and replace an external CF card, complete the following steps:

1. Shut down the operating system.
2. Turn off the system.



### Warning

Always make sure that the system is turned off when inserting or removing a CF card. Inserting or removing a CF card while the system is on can damage the CF card.

3. Press the eject button next to the external CF slot, and remove the card by sliding it out of its slot toward you.
4. Reinstall the CF card by carefully inserting it into its slot and pushing it into the slot until the card is securely seated (the eject button should pop out).



### Important

When inserting a CF card, align the arrow on the card with the arrow that appears over the CF slot.

---

## Ports

The P1-10" PowerStation has the following ports:

- Three 16C550-compatible external serial ports
- One standard parallel port that supports Standard Parallel Port (SPP), Enhanced Parallel Port (EPP), and Enhanced Capability Port (ECP) standards
- Two PS/2 ports (one each for mouse and keyboard).
- One 10/100 Base-T Ethernet port

The following illustrations show the location of these ports; the sections that follow explain the ports' uses and give pinout information.

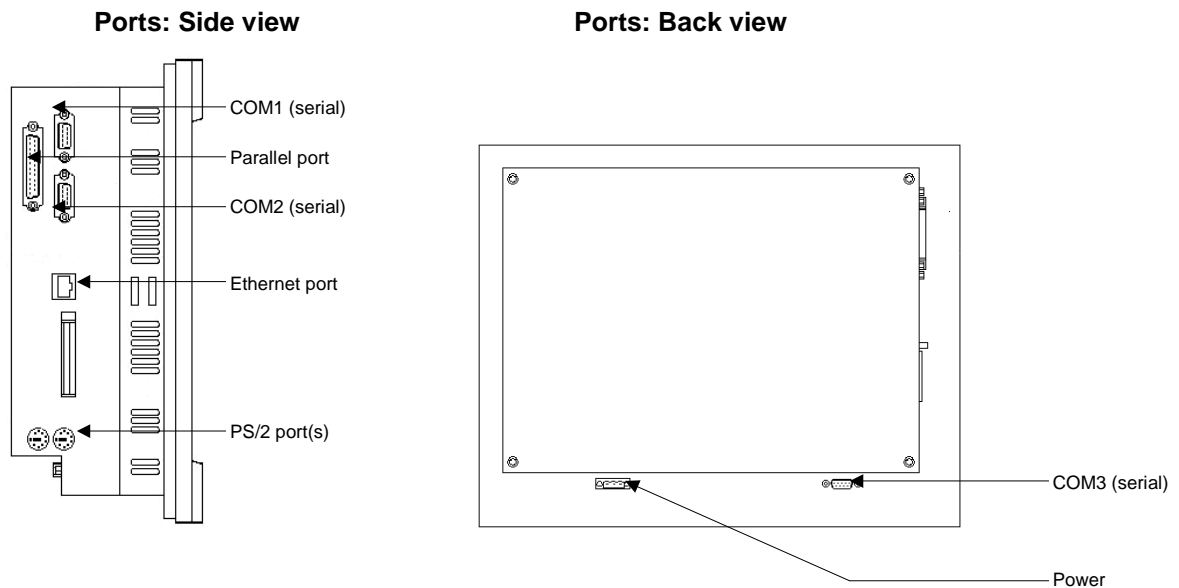

## Serial Ports

The P1-10" PowerStation has three external serial ports:

- These ports are identified as COM1, COM2, and COM3.
- COM1 and COM2 are located on the left side of the unit; COM3 is located at the back of the unit.
- All three ports use standard, 9-pin, Male, D-sub connectors. See the illustration on page 21.

Communication standards for these ports are shown in the following table.

Port	Communication Protocol
COM1 COM3	Configurable for RS-232 only.
COM2	Configurable for RS-232, RS-422, and RS-485. The default protocol (as shipped) is RS-485.

---

**Note** The system's touchscreen connector, located on the CPU card, is an internal serial controller designated as COM4.

---

When configuring COM2 for connection with a programmable logic controller (PLC), the communication standard you select for COM2 depends upon the distance between the system and the controller, as well as the communication standards that the controller supports:

- If you are using RS-232 communications, the length of the serial cable should not exceed 50 feet (15 meters).
- RS-422 and RS-485 communications offer greater noise immunity than RS-232 and increase the maximum cable length to 4,000 feet (1,200 meters).
- RS-422 communications are full-duplex (can send and receive simultaneously).
- RS-485 communications are half-duplex (can only send or receive at one time).
- For information on the specific connections required for Interact or MachineLogic drivers, look in the Help file associated with the driver.

### COM1, 2, and 3 Pinouts

If you need to make a cable for communicating with COM1, COM2, or COM3, the pinout and signal information for these ports is shown below:

**Note** COM2 is configurable for RS-232, RS-422, and RS-485; its default setting is RS-485.

Pin #	RS-232 (COM1, 3 default)	RS-422	RS-485 (COM2 default)
1	DCD, data carrier detect	TX-, transmitted data -	TX-, transmitted data -
2	RX, received data	TX+, transmitted data +	TX+, transmitted data +
3	TX, transmitted data	RX+, received data +	RX+, received data +
4	DTR, data terminal ready	RX-, received data -	RX-, received data -
5	GND, signal ground	GND, signal ground	GND, signal ground
6	DSR, data set ready	DSR, data set ready	DSR, data set ready
7	RTS, request to send	RTS, request to send	RTS, request to send
8	CTS, clear to send	CTS, clear to send	CTS, clear to send
9	RI, ring indicator	RI, ring indicator	RI, ring indicator

The following illustration shows the cable diagrams for the RS-232, RS-422, and RS-485 protocols.

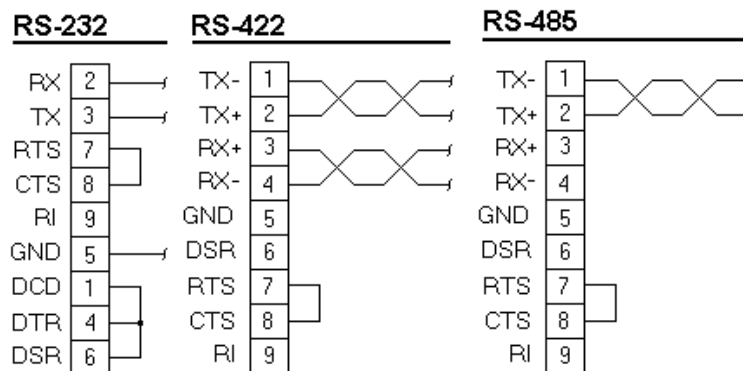

## Connecting to a PC

If you want to transfer files via serial connection from another PC to a P1-10" PowerStation, connect a serial cable with a null modem between available serial ports on each system. If you need to construct your own cables, refer to the following diagrams:

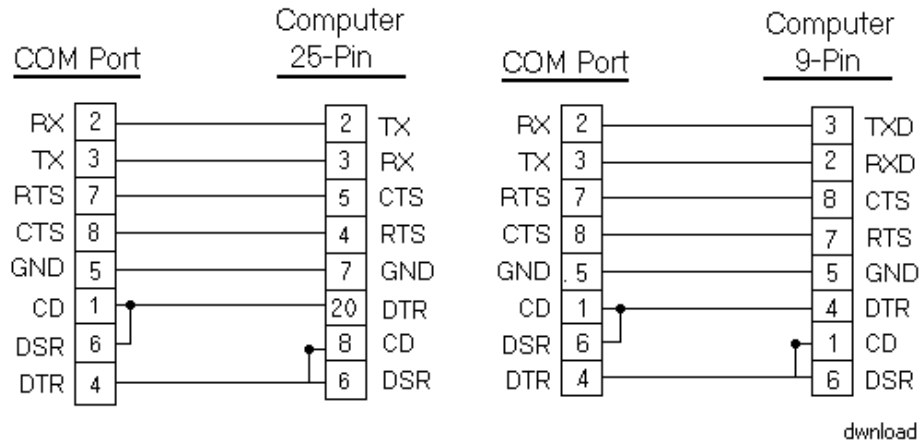

### Important

Do not connect any wires to unused connector pins.

## Parallel Port

The P1-10" PowerStation has one parallel port, located on the left side of the unit. See the illustration on page 21.

Pinout data for the parallel port is shown below:

Pin #	Signal Name	Pin #	Signal Name
1	STB (- Strobe)	10	ACK (- Acknowledge)
2	PD0 (+ Data Bit 0)	11	BUSY (+ Busy)
3	PD1 (+ Data Bit 1)	12	PE (+ Paper End)
4	PD2 (+ Data Bit 2)	13	SLCT (+ Select)
5	PD3 (+ Data Bit 3)	14	AFD (- Auto Feed)
6	PD4 (+ Data Bit 4)	15	ERR (- Error)
7	PD5 (+ Data Bit 5)	16	INIT (- Initialize Printer)
8	PD6 (+ Data Bit 6)	17	SLIN (- Select Input)
9	PD7 (+ Data Bit 7)	18-25	GND (Ground)

The P1-10" PowerStation can interface with any parallel printer designed for use with PCs. Connect a printer to the parallel port, using a standard PC parallel cable.

## PS/2 Ports

The P1-10" PowerStation has two PS/2 ports located at the left side of the unit—one to connect a keyboard to the system and the other to connect a mouse. See the illustration on page 21.

Pinout data for PS/2 ports is shown in the table below:

Pin	Signal Name	Pin	Signal Name
1	Data	4	+5V (Fused)
2	NC	5	Clock
3	GND	6	NC

## Ethernet Port

The P1-10" PowerStation has an Ethernet RJ-45 port that allows you to connect the unit to a local area network (LAN). See the illustration on page 21.

This port uses an Intel 82559 10/100 Mbps PCI Fast Ethernet controller with an integrated IEEE 802.3 10Base-T and 100Base-TX interface.

Pinout data for this port is shown in the following table:

Pin#	Signal	Pin#	Signal
1	TX+	5	75 Ohm Terminator
2	TX-	6	RX-
3	RX+	7	75 Ohm Terminator
4	75 Ohm Terminator	8	75 Ohm Terminator

## Power Supply

The P1-10" PowerStation is powered by 24VDC @ 3.25A. The input voltage range is 18VDC-28VDC. All system voltages, such as +/-5V, +/-12V, 3.3V, and CPU voltages are generated on the CPU card from the 24VDC input voltage.

The power supply is designed to protect against the following:

- Misapplication of 120VAC to the DC input connector
- Damage caused by reverse polarity DC input connections

In either case, the extent of damage to the electronics would be limited to blowing the input fuse.

For information about the fuse, see **Fuse** below. For more information about the P1-10" PowerStation power supply, see **Testing Specifications** on page 72.



## Battery

The P1-10" PowerStation uses a 3.0V socket battery for real-time clock backup and CMOS storage. The battery is located on the CPU card (see the illustration on page 17) and is replaceable with a standard CR2032 battery.



### Caution

For units with replaceable Lithium batteries:

- There is danger of explosion if the battery is incorrectly replaced.
  - Replace the battery only with the same type of battery or an equivalent type recommended by the manufacturer.
  - Dispose of used batteries according to the manufacturer's instructions.
- 

## Fuse

The P1-10" PowerStation has a 5A fuse located on the CPU card (see the illustration on page 17). The fuse is a 250VAC Littelfuse, part #216.315. It is field replaceable by the same model fuse or its equivalent.

---

**Important** Only qualified service personnel should replace the fuses.

---

## System Peripheral Devices

System peripheral devices in the model P1-10" PowerStation include the watchdog timer and the PowerSmart system monitor.

### Watchdog Timer

The P1-10" PowerStation's CPU card supports a Watchdog Timer. If the processor does not read or write to the timer register within 1.6 seconds, the timer will reset the computer.

You can configure the Watchdog Timer within CTC's Interact software. If you are an Interact user and want to learn how to configure the Watchdog Timer, open the Interact Application Manager online help, and look under *Application Settings*.

### PowerSmart

The P1-10" PowerStation comes with a PowerSmart system monitor that continuously monitors the following on a system:

- Five internal power supply voltages
- Internal temperature
- Total hours that the system has been in operation
- Communication errors in system monitoring devices

To access the PowerSmart display on a P1-10" PowerStation, complete the following steps:

1. At the `C:\` prompt, type `pwrsmrt`.
2. Press **Enter**.

The system's conditions will display.

---

**Note** PowerSmart continuously monitors the system regardless of whether the display is shown.

---

See *Problems Signaled by PowerSmart* on page 60 for suggestions about how to respond to error conditions.

To perform its functions, PowerSmart uses the I2C devices shown in the table below. All devices are connected on a two-wire SMBus.

PowerSmart I2C Device	Location	Function
MicroController (87LPC764)	CPU card U38	Programs and monitors all other peripheral devices on the bus. Determines the presence of error conditions. Logs error counts, temperature extremes, and hours of operation. Communicates error and status information to the SMBus host interface.
Peripheral monitor (DS1780)	CPU card U41	Monitors power supply voltages and temperature.
EEPROM (24C02)	CPU card U39	Stores error counts, temperature extremes, operation hours, and system configuration information.

## Expansion Slots

The model P1-10" PowerStation supports up to 3 PC/104 expansion cards on the PC/104 socket. The maximum depth for expansion slots is 11".

---

**Note** Ensure that the total current requirements for all expansion cards installed does not exceed the expansion slot electrical specifications as listed on page 72.

---

## I/O Addresses

The following table shows the I/O addresses used by the P1-10" PowerStation:

Address	Function
0000-000F	DMA controller 1
0020-0021	Interrupt controller 1
0040-0043	Counter timer 1
0048-004B	Counter timer 2
0060/0062	Keyboard, NMI, speaker
0061/0063	Watchdog timer
0070-0071	Real time clock/NMI mask
0080-008F	DMA page register, POST checkpoint
00A0-00A1	Interrupt Controller 2
00C0-00DE	DMA Controller 2
00F0-00FF	Numeric co-processor
0170-0177	Secondary IDE channel
01F0-01F7	Primary IDE channel
0278-02FF	Parallel port 2 (CTC software security key)
02E8-02EF	Serial port 4 (default)
02F8-02FF	Serial port 2 (default)
0376	Secondary IDE port
0377	Floppy channel 2 command
0377 bit 7	Floppy disk change, channel 2
0377 bit 0:6	Secondary IDE channel status port
0378-037F	Parallel port 1 (default)
03BC-03BF	Parallel port 3 (opt)
03E8-03EF	Serial port 3 (default)
03F0-03F5	Floppy channel
03F6-03F7	Primary IDE and floppy
03F8-03FF	Serial port 1 (default)
04D0-04D1	Edge/level interrupts
0CF8-0CFF	PCI configuration

## IRQs

The P1-10" PowerStation configures IRQs in the following manner:

IRQ	Default
NMI	Parity/System errors
0	System timer
1	Keyboard
2	Cascade for IRQ 8-15
3	COM2
4	COM1
5	Available
6	Floppy controller
7	Parallel port 1
8	Real-time clock
9	COM3
10	Available
11	Touch screen
12	Reserved/PS/2 mouse
13	Co-processor
14	Primary IDE
15	Reserved

## Memory

This section describes the SDRAM available in the P1-10" PowerStation, the way in which the PowerStation allocates memory, and memory guidelines for Interact software users.

### Memory Modules

The P1-10" PowerStation comes with 32MB of SDRAM soldered onto the CPU card in four 8MB chips. In addition, a single socket on the CPU card can accommodate up to 256MB of SDRAM. Maximum total memory supported by the CPU card is 256MB.

---

**Note** For additional information about the P1-10" PowerStation's memory, see *Physical Specifications* on page 68.  
If you need to replace memory modules, see the table of *Recommended SDRAM Manufacturers* on page 69.

---

### Memory Map

The following table shows how the P1-10" PowerStation allocates conventional and extended memory. Available address references are listed next to each device.

Function	Address Range (decimal)	Address Range (hex)	Size
Extended memory	1024K-524288K	100000-20000000	511MB
Boot block	1008K-1024K	FC000-FFFFFF	16KB
ESCD	1000K-1008K	FA000-FBFF	8KB
Phoenix system BIOS	896K-1000K	E0000-F9FF	104KB
Available upper memory	800K-896K	C8000-DFFFF	96KB
Video memory and BIOS	640K-800K	A0000-C7FFF	160KB
Conventional memory	0K-640K	00000-9FFFF	640KB

### Memory Guidelines

If you are using Interact software, follow the memory guidelines listed in the table below. If you are not using Interact, you can skip this section.

Memory Type	Runtime	Development
System SDRAM	32MB min. of system memory	32MB of system memory required
CompactFlash		8MB external CompactFlash can store APM, AMM, GMM, and PTM, plus four additional runtime modules, two drivers, and approximately thirty screens. Extra modules require greater storage capacity (four modules/MB). Log data to the CF only if its size is sufficient.

# CHAPTER 3: INSTALLATION

This chapter provides guidelines for selecting an appropriate location for the model P1-10" PowerStation. It also gives instructions for mounting the system in an enclosure and starting the system.

## Chapter Contents

---

<i>Selecting a Location</i> .....	31
<i>Mounting the System</i> .....	33
<i>Starting the System</i> .....	34

## Selecting a Location

The first step in installing your model is to select an appropriate location. This is the most important aspect of installation because the location you select will affect the system's performance, ease-of-use, and life expectancy. This section provides guidelines to follow when selecting a location.

### Class I, Division 2 Guidelines

If you purchased a Class I, Division 2-compliant computer, always follow these guidelines in order to maintain a safe operating environment:



#### Warning

**Explosion Hazard**—Substitution of components may impair suitability for Class 1, Division 2.

**Explosion Hazard**—Do not disconnect equipment or replace or insert cards unless power has been switched off, or the area is known to be non-hazardous.

- 
- The computer is suitable for use in Class I, Division 2, Groups A, B, C, and D hazardous locations only.
  - If you are using AC power and mounted a CTC Parker AC adapter on your computer, make sure that the power cord is secured to the computer using the supplied L-bracket.

### Environmental Guidelines

The environment is the location where the system will be installed.



#### Caution

In general, select a place that limits the system's exposure to adverse conditions, such as dust, oil, moisture, and corrosive vapors.

### Faceplate Considerations

The faceplate is designed for a Type 4/4X environment. The system's faceplate is resistant to a variety of chemicals. See *Appendix A: Faceplate Chemical Resistance* on page 73 for a complete list.

---

**Important** The system is only rated for NEMA 4 when it is installed in a UL listed NEMA 4X enclosure.

---

### Electrical Guidelines

To minimize unwanted electrical interference, select a location away from machinery that produces intense electrical noise (arc welders, for example).

If you cannot avoid electrical noise, isolate input power to the system, and separate all data communication cables from power lines.



**Important**

In order to comply with UL 508 and 1604 requirements, use copper wire with 60C or 60/75C insulation and a tightening torque of 7.0 lb./in. (0.79 N-m) when connecting field terminal wiring to the system.

To comply with UL 60950 requirements for permanently connected equipment, a readily accessible disconnect device shall be incorporated in the building installation wiring.

---

**Note** The P1-10" PowerStation accepts DC input only. To apply AC power, you must use an AC adapter. You can purchase an AC adapter from your local distributor.

---

Make sure that your power source is completely compatible with the system before starting up. (See *Appendix A: Electrical Specifications* on page 72.)

## Temperature Guidelines

You should safely operate the system within the temperature range specified in the *Environmental Specifications* on page 71.

---



**Warning**

If the system is operating inside an enclosure at temperatures above its rated ambient temperature, you must cool the enclosure.

---

## Enclosure Guidelines

Select an enclosure that is large enough to allow free airflow in and around the system.

See *Appendix B: Dimensional Drawings*, on page 75, for the measurements you will need to mount your system. These include the unit's height, width, and depth; and location measurements for drives, ports, and controls).

- Allow a minimum of 2 inches around the unit for airflow.
- See Accessing Ports, Drives, and Other Controls below for additional guidelines.

Make sure that the surface where the unit will meet the front panel of the enclosure is flat in order to ensure a NEMA seal.

## Accessing Ports, Drives, and Other Controls

As shown in the illustrations on page 21, two of the serial ports, the printer port, PS/2 mouse and keyboard ports, Ethernet port, and external CF slot are located on the left side of the unit on the model P1-10" PowerStation. At the back of the unit are an additional serial port and the power connector. Be sure to design your enclosure with these locations in mind.

See *Appendix B: Dimensional Drawings*, on page 75, for the location measurements of your system's drive, ports, and controls. Use these dimensions to customize the mounting of your unit.



## Mounting the System

To mount the model P1-10" PowerStation, complete the following steps:

---

**Note** Necessary mounting clamps and screws are shipped with your system.

---

1. Cut a space where you can mount the unit.

The cutout dimensions for the P1-10" PowerStation are shown in the following table and in *Appendix B: Dimensional Drawings* on page 75.

Cutout Height	Cutout Width
9.86" (250.44mm)	12.60" (320.04mm)

2. Debur the cutout area.
3. Make sure that both sides of the panel mounting surface are clean and flat.
4. Slide the unit into the cutout from the front.
5. Attach the mounting clamps to the back of the unit, as shown in the following illustration:

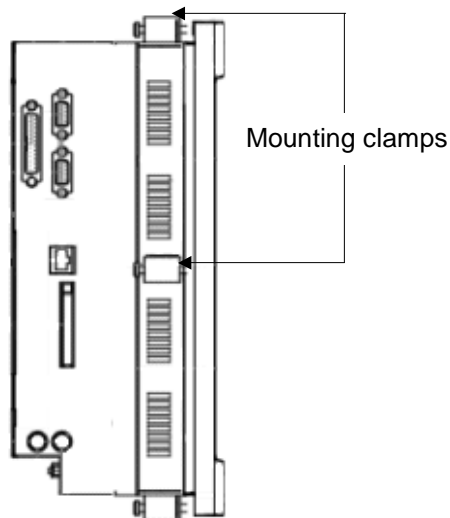

6. Attach 6 mounting clamps, with their screws, to the back of the unit in the spaces provided. You will place 2 clamps at the top and bottom of the unit and 1 on each side, as shown above.

---

**Note** The prongs at the bottom of each clamp should face backward and hook into the slots in each space. The end of each screw should point toward the front of the enclosure. See the illustration below.

---

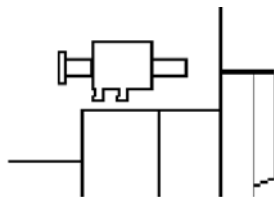

7. Tighten each screw against the front of the enclosure to a torque of 8 lb./in.

## Starting the System

Before you connect power to the unit, make sure that you have read and understood the *Electrical Specifications* on page 72 and *Testing Specifications* on page 72. Also, make sure that you follow the guidelines listed below:

- For permanently connected equipment, a readily accessible disconnect device must be incorporated into the fixed wiring.
- For pluggable equipment, the socket-outlet must be installed near the equipment and should be easily accessible.



### Important

Proper installation of the system in European Union countries requires the use of a harmonized power cord (the power cord must be identified with the <HAR> symbol). Make sure that the system is connected to the main supply with a harmonized power cord.

---

To start the system, complete the following steps:

1. Connect the power cord to a voltage source.

Voltage input to the system should be within the range specified in *Electrical Specifications* on page 72.

2. Connect the power cord to the system.
3. Turn the system on.

When you run a P1-10" PowerStation, MachineShop Shell will automatically be loaded at startup.

You are now ready to begin using your system.

- If you are using Interact software, refer to the *Interact Getting Started Guide* for help in developing your projects.
- Refer to the *MachineShop Getting Started Guide* for information about how to download projects.





# CHAPTER 4: MAINTENANCE

Occasionally, you may need to perform routine maintenance on some system components. This chapter provides instructions for maintenance, as well as steps for solving problems that may occur during operation.

## Chapter Contents

---

<i>BIOS Setup</i> .....	38
<i>Reinstalling the PowerStation Utilities</i> .....	40
<i>Maintaining the Display</i> .....	42
<i>Performing Internal Maintenance</i> .....	46

## BIOS Setup

If you want to reset any of the BIOS settings, press the **F2** key while the system is starting up to display the BIOS setup window. The BIOS setup window allows you to complete the following tasks:

- Configure the serial ports
- Load the default BIOS settings
- Remove the CTC splash screen

To access the BIOS settings, complete the following steps:

---

**Note**      Accessing the BIOS settings requires a keyboard.

---

1. Shut down the system.
2. Connect a keyboard to the system.
3. Restart the system.
4. While the system is starting, press the **F2** key on your keyboard.
5. The BIOS Setup Utility screen will appear.

## Configuring Serial Ports

To configure the serial ports, complete the following steps:

6. Start the system, and while the system is starting, press the **F2** key on your keyboard.

The BIOS Setup Utility screen will appear.

7. Select the **Advanced** tab.
8. Scroll down to **PCI Configuration: I/O Device Configuration**.
9. Press **Enter**.

A list of Serial Ports is displayed. See the table below.

Serial Ports	Address	IRQ
A	3F8	4
B	2F8	3
C	2E8	9
Touchscreen	3E8	11

---

**Note**      The default setting for the touchscreen is [Enabled].

---

10. To configure all serial ports to the factory defaults, press **F9**.

## Loading Default BIOS Settings

To reload the default BIOS settings, complete the following steps:

1. Start the system, and while the system is starting up, press the **F2** key on your keyboard.  
The PhoenixBIOS Setup Utility screen will appear.
2. In the **Exit** menu, select the **Load Setup Defaults** option.
3. In the Advanced menu, change **Reset Configuration Data** to **Yes**.

---

**Note** When the system restarts, this setting will automatically switch back to **No**.

---

4. Save these settings, and exit the setup program.
5. Restart the system.

When the system restarts, the default BIOS settings will be re-established.

## Removing the CTC Splash Screen

1. Start the system, and while the system is starting up, press the **F2** key on your keyboard.  
The BIOS Setup Utility screen will appear.
2. From the **Main** tab of the BIOS, **scroll down** to **Boot-time Diagnostic Screen** as shown below.

PhoenixBIOS Setup Utility				
Main	Advanced	Security	Power	Exit
System Time			[16:19:20]	Item Specific Help <Tab>, <Shift-Tab>, or <Enter> selects field
System Date:			[03/02/1994]	
Legacy Diskette A:			[1.44/1.25 MB 3½"]	
Legacy Diskette B			[Not Installed]	
▶	Primary Master	6449 MB		
▶	Primary Slave	None		
▶	Secondary Master	CD-ROM		
▶	Secondary Slave	None		
Memory Cache			[Enabled]	
▶	Keyboard Features			
System Memory			640 kB	
Extended Memory			31744 kB	
<b>Scroll down to see the following two options</b>				
Boot-time Diagnostic Screen			[Disabled]	
▶	Boot Options			
F1 Help	↓ Select Item	-/+ Change Values	F9 Setup Defaults	
ESC Exit	↔ Select Menu	Enter Select	▶ Sub-Menu	F10 Save and Exit

3. Press the + key to toggle the **Boot-time Diagnostic Screen** setting to **[Enabled]**.

## Reinstalling the PowerStation Utilities

The P1-10" PowerStation is shipped with the operating system and all of the other software that you purchased. This software is installed on the external CompactFlash card that came with your system. (See *Using CompactFlash* Cards on page 19 for information about how CF cards work in your system.)

Backup copies of your software are provided on the CD, P1 PowerStation Family Documentation, that shipped with your system. If any of the software on your system becomes lost or corrupted, you can reinstall it from this distribution disk.

## Restoring a CompactFlash Card

When you use a CompactFlash (CF) card as the startup drive in a PowerStation, you may need to create a bootable CF card for the system from a blank or used card. This procedure will fix a DOS Shell CompactFlash card and allow you to do the following:

- Reinstall the PowerStation Utilities onto a CF card
- Prepare a new CF card for use

You can easily reformat a CompactFlash card by using CTC's FlashBack utility, which restores the MS-DOS operating system and PowerStation operating files to a CF card in one operation.

When you use FlashBack, the following software will be replaced onto your CompactFlash card:

- Operating system
- System drivers
- MachineShop Shell

## Writing to the CompactFlash Card

In order to write to the CompactFlash card, you will need one of the following:

- A personal computer running Windows with a CD-ROM drive and a SanDisk ImageMate. A SanDisk ImageMate is a CompactFlash reader/writer that connects to the personal computer through a USB port. You can order a SanDisk ImageMate (model number IMG-2000) from your local distributor.
- A laptop computer running Windows with a CD-ROM drive and a PCMCIA-to-CompactFlash adapter. The PCMCIA-to-CompactFlash adapter allows you to read from or write to a CompactFlash card through your laptop's PCMCIA slot. You can order a PCMCIA-to-CompactFlash adapter (model number FLH-ADPT-2000) from your local distributor.



## Reformatting the CompactFlash Card



### Warning

Manually formatting a CompactFlash Card in Windows NT and 2000 before using FlashBack overwrites the systems files that make the CF card bootable. Removing the CompactFlash card: during a disk transfer procedure, **do not** remove the CF card before issuing a Stop or shutting down the OS. Otherwise, the last part of the data will not transfer to the CF card.

To reformat a CF card for a model P1-10" PowerStation, complete the following steps on a personal computer or laptop:

1. Insert the CompactFlash card into the SanDisk ImageMate or the PCMCIA slot.
2. Insert the P1 PowerStation Documentation CD into the CD-ROM drive.
3. Use Windows Explorer to locate the file **FlashUtil.exe** from the **Utilities** directory on the CD-ROM drive.
4. Double-click **FlashUtil.exe**.

The FlashBack Utility dialog box will appear.

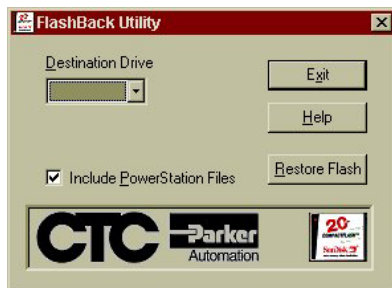

5. Click the **Help** button to find complete, online instructions for using the FlashBack utility.

**Note** Make sure that you are using at least revision 104 of the FlashBack utility, which allows the formatting of the CF card even if the boot sector of the CF card is unreadable to DOS.

Reformatting a CompactFlash card using FlashBack will erase your projects from the CF card. You will need to download your projects to the CF card again. After using FlashBack, you may also need to recalibrate your PowerStation display. For instructions, see *Recalibrating the Touchscreen* on page 44.

## Installing PowerSmart for MS-DOS

PowerSmart is a utility that allows you to monitor the system's conditions. (See *PowerSmart* on page 26 for more information.)

PowerSmart is not pre-loaded on the CompactFlash card that shipped with your system. To use PowerSmart on your P1-10" PowerStation, you must copy PowerSmart from the included P1 PowerStation Documentation CD to your CompactFlash card. (See *Writing to the CompactFlash Card* on page 40 for a description of the hardware required to complete this operation.)

## Maintaining the Display

This section contains instructions for the following:

- Cleaning the display screen
- Reconfiguring the touchscreen driver
- Recalibrating the touchscreen

### Cleaning the Display Screen

Follow the guidelines below when you clean the display screen:

- You may clean the display screen using warm, soapy water and a cloth.
- You may also use any non-abrasive cleaner.
- Do not use any harsh material or powder, such as steel wool or abrasive cleansers.
- See *Faceplate Chemical Resistance* on page 73 for a list of substances the screen can resist with no visible effect.



#### Important

Interact users: **Do not** clean the unit while Interact is in Run mode. Clean the unit only when power is off to keep from inadvertently activating an Interact device (button, slide, etc.).

---

The touchscreen surface is sensitive to scraping, sharp blows, or punctures. Therefore, keep screwdrivers or other sharp objects away from the surface.

## Reconfiguring the Touchscreen Driver

CTC Parker Automation will ship your system with the TouchBase touchscreen driver installed and configured. You may have to reconfigure the touchscreen driver for one of the following reasons:

- If it becomes corrupted
- If you reinstall it
- If you wish to change the touchscreen IRQ or address settings in your computer

To reconfigure the touchscreen driver, first change the BIOS settings. Then, edit the Autoexec.bat file.

### Change the BIOS settings

---

**Note** This procedure requires a keyboard.

---

1. Start the system, and while the system is starting, press the **F2** key on your keyboard.

The BIOS Setup Utility screen will appear.

2. Select the **Advanced** tab.
3. Scroll down to **PCI Configuration: I/O Device Configuration**.
4. Press **Enter**.

A list of Serial Ports is displayed.

5. Change the IRQ or address settings for the touchscreen.

The table below lists the default IRQ and address settings.

Serial Port	Address	IRQ
Touchscreen	3E8	11

6. Continue to the next section, *Edit the Autoexec.bat file*.

### Edit the Autoexec.bat file

---

**Note** This procedure requires a keyboard. This procedure may require a personal desktop computer or laptop. See *Determining system requirements* in the *Problems with the Autoexec.bat or Config.sys file* section on page 65 before you complete the following procedure.

---

1. Complete the steps in *Modifying an existing file* on page 65. Then, continue to step 2.
2. Select one of the following:
  - If you wish to re-establish the factory default settings for your touchscreen address and IRQ, make sure that the following lines near the beginning of the Autoexec.bat file read as follows:
    - SET TOUCH\_ADDR=3E8
    - SET TOUCH\_IRQ=11
  - If you intend to change the touchscreen settings, change the preceding lines to reflect the new touchscreen address and IRQ.
3. If you modified the file with a DOS text editor, you must restart your P1-10" PowerStation in order for your changes to take effect.

## Recalibrating the Touchscreen

Your system's touchscreen will be calibrated at the factory. However, you may need to calibrate the touchscreen when you use the system for the first time or whenever the cursor location does not match the place on the screen where the user touches it. You can calibrate the touchscreen under DOS from the MachineShop Shell.

To recalibrate the touchscreen, complete the following steps:

---

**Note** This procedure requires a keyboard.

---

1. On the MachineShop Shell main menu, press the **SETTINGS** button.

The Settings submenu will appear.

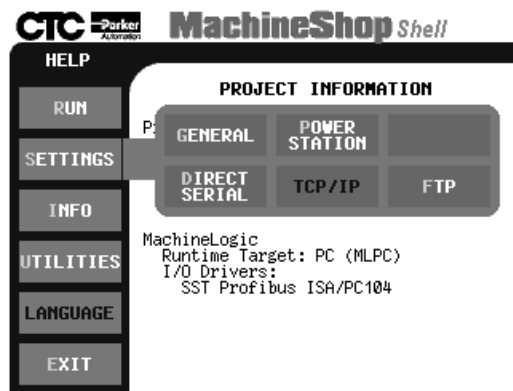

2. Press the **POWER STATION** button.

The PowerStation Settings submenu will appear.

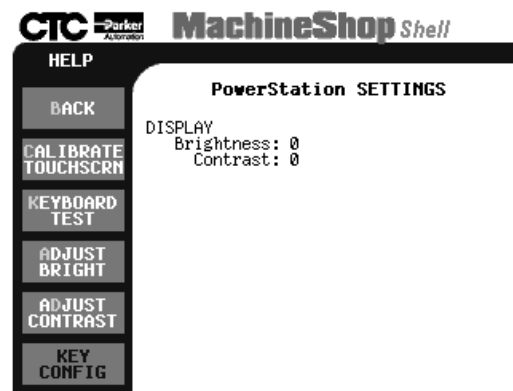

3. On the PowerStation Settings submenu, press the **Calibrate Touchscrn** button.

The prompt will indicate that a keyboard is needed to calibrate the touchscreen. Then it will ask if you want to continue.

4. Connect a keyboard to the system, if none is connected.
5. After you connect a keyboard, press the **Yes** button to continue the calibration.

The Touchscreen Calibration screen will appear.

```
The calibration program will now be started automatically. To
calibrate your touchscreen, perform the following steps in the
calibration program.
```

- Select "H" to perform a Hard calibration.
- Select "X" to exit the calibration utility when finished

```
Press any key to continue . . .
```

6. Press any key on the keyboard when you are ready to begin calibration.

The Touchscreen Driver Configuration screen will appear.

```
DynaPro Thin Film Products Inc.      (c) Touch-Base Ltd. 1989-2000
Touchscreen Calibration Program (EEPROM version)   Version 4.26

----- Main Menu -----
H - Hard calibrate
T - Test menu
F - Display calib details
X - Exit

You must hard calibrate if you have not yet done so.
```

7. Type **H** for Hard Calibration.
8. Follow the on-screen directions by pressing the targets on the display when they appear.
9. Press **Esc** or **X** to exit the calibration utility.



### Important

After calibrating the touchscreen, verify that the cursor appears on the screen where you touch. If it does not, recalibrate the touchscreen. The calibration must be accurate to avoid activating a button unintentionally during Run mode.

## Performing Internal Maintenance

This section includes the following information about performing internal maintenance on the PowerStation P1-10":

- Replacing field-replaceable components
- Observing electrostatic discharge (ESD) precautions
- Opening and closing the system
- Adding expansion cards
- Changing jumper settings

## Replacing Components

The following components are field-replaceable.

- Backlight bulbs
- Battery
- Fuse
- SDRAM modules
- Touchscreen

Instructions for replacing these components can be found on the CTC website [www.ctcusa.com](http://www.ctcusa.com) at the Support web link "Product Manuals".

We recommend that you order replacement components and installation kits from CTC Parker at 513-831-2340.

- Replacement components purchased from CTC are designed and tested to work effectively in your system.
- Complete installation instructions are included with each item.

---

**Note**      If you wish to purchase replacement components from another source, check the table of *Recommended SDRAM Manufacturers* which appears on page 69.

---

## Observing ESD Precautions

Modern integrated electronic devices, especially circuit cards and memory chips, are extremely sensitive to electrostatic discharges (ESD) and fields. Before you open the system, be sure to follow these simple precautions to protect you and the unit from harm resulting from ESD:



### Electrostatic Discharge Warning

- Always disconnect the power from the PowerStation before opening or disassembling the unit. **Do not** touch any components on the CPU card or other cards while the PowerStation is on.
- Disconnect power before making any hardware configuration changes. The sudden rush of power as you connect a jumper or install a card may damage sensitive electronic components.
- Only handle internal components in an ESD-safe location, using appropriate grounding methods.
- Wear a grounding wrist strap for continuous protection.
- Always ground yourself to remove any static charge before you touch the CPU card.
- Do not touch the chip connectors.
- Keep any card or SDRAM module in its anti-static packaging when it is not installed in the PowerStation. Place it on a static dissipative mat when you are working on it.

## Opening and Closing the System

In order to perform internal maintenance on a PowerStation, you will have to access the inside of the unit. The P1-10" PowerStation has two main parts: the backshell and the faceplate. The faceplate assembly includes the bezel.

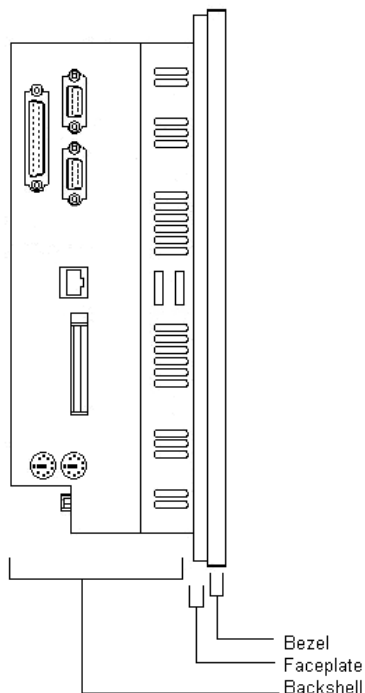

## Opening the System

---



### Warning

For safety reasons, only qualified service personnel should open the PowerStation.

---

### Access the CPU board

To open the backshell and access the CPU board, complete the following steps:

1. Turn off the system.
2. Disconnect the system from the power source.
3. Disconnect all cables attached to the system.
4. Remove the screws from the backplate of the unit (see the illustration below) and set aside.

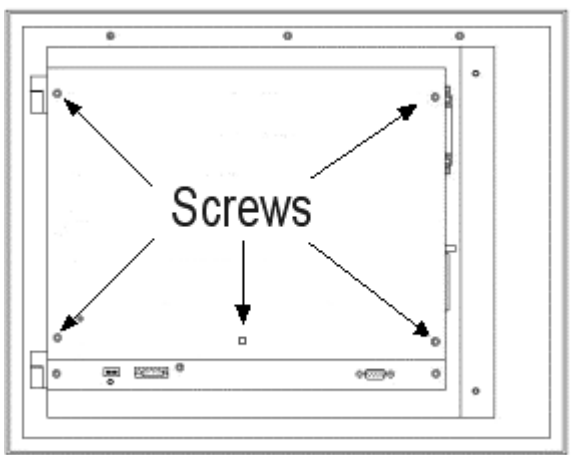

The backplate is removed and the CPU board is accessible.



## Access the display

**Note** If your system is mounted, you must remove it from its enclosure in order to perform the following procedure.

1. Remove the backplate, see *Access the CPU Board* on page 48.
2. Detach the flat panel cable.
3. Detach the touchscreen cable.
4. Remove the 12 screws on the sides of the unit that attach the backshell to the bezel.

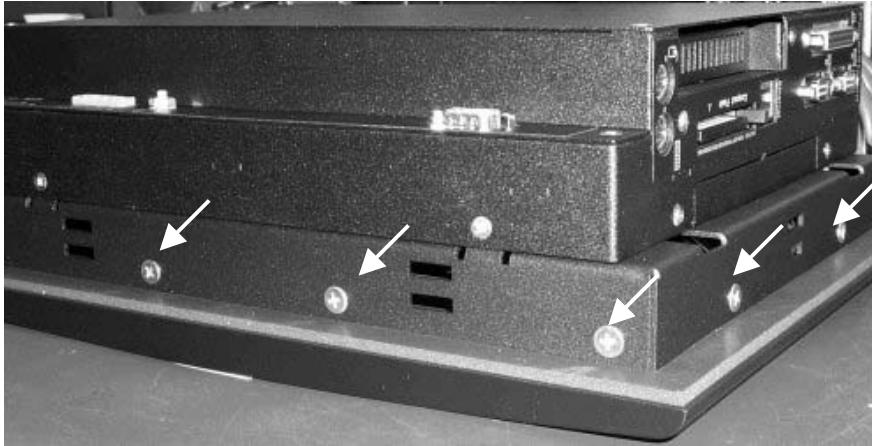

5. Tilt the backshell to one side and slide the cables through the slot on the backshell.
6. Set the backshell aside.

## Closing the System

### Reassemble the P1-10"

To reassemble after accessing the display, complete the following steps:

1. Slide the cables back through the slots on the backshell.
2. Place the backshell on the faceplate.
3. Screw in the 12 screws on the sides of the unit that attach the backshell to the bezel.
4. Reattach the flat panel cable and the touchscreen cable to the CPU board.
5. Complete the steps for installing the backplate on page 49.

### Install the backplate

To install the backplate on the unit, complete the following steps:

1. Place the backplate onto the unit.
2. Secure the backplate using the five screws removed when disassembling the unit.

The backplate is installed.

## Changing Jumper Settings

Like other PCs, the P1-10" PowerStation uses jumpers to control some system functions. This section explains how to change jumper settings in order to:

- Enable or disable the Ethernet port
- Change the communication protocol for COM2
- Clear the system's CMOS settings



### Important

Other jumpers have been factory set for optimal system performance and should **not** be changed.

---

## Jumper Locations

Locations of the PowerStation's configurable jumpers are shown in the illustration below.

### CPU Card and Configurable Jumpers

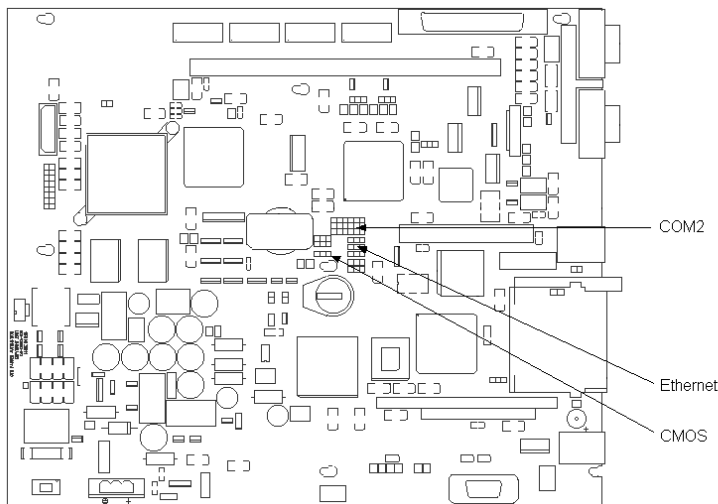

To change jumper settings, first open the backplate (see *Opening the system* on page 48 for instructions). Jumpers set to “on” and “off” should look like those shown below.

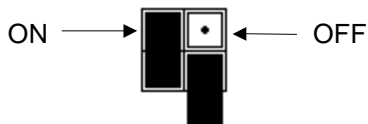

---

**Note** “Off” jumpers can be completely removed or set as in the illustration above.

---

## Ethernet Port

The **ENET** jumper controls the Ethernet port (see the configurable jumpers illustration above for this jumper's location). The default setting, with the Ethernet port enabled, is shown below.

### Enabled (default)



To disable the Ethernet port, set the jumper as shown below.

### Disabled



## COM2 Communication Protocol

Jumpers that set the communication protocol for COM2 are shown in the configurable jumpers illustration the previous page.

The default protocol for COM2 is RS-485. Jumper settings for this protocol are shown in the following illustration.

### RS-485

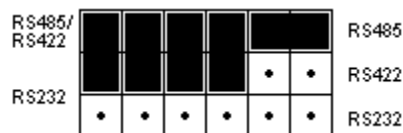

If you want the protocol to be RS-422, set the jumpers as shown in the following illustration.

### RS-422

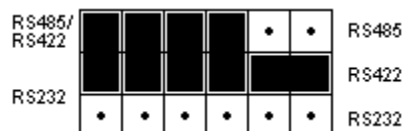

If you want the protocol to be RS-232, set the jumpers as shown in the following illustration.

### RS-232

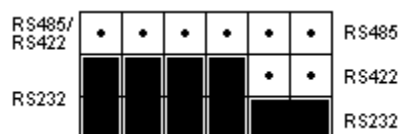

---

**Note** See also Serial Ports on page 21. For pinout information on all three serial ports, see *COM1, 2, and 3 Pinouts* on page 22.

---

## CMOS Settings

Jumpers **E52**, **E53**, and **E54** enable you to clear the computer's CMOS settings. See the illustration on page 50 for the location of these jumpers. The default setting is shown below.

### Default



To clear the CMOS settings, complete the following steps:

1. Set the jumpers as shown below.

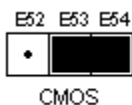

2. Wait a few seconds.
3. Reset the jumpers to the default settings.





# CHAPTER 5: TROUBLESHOOTING

This chapter provides basic troubleshooting steps to help you identify and correct problems that you may have with your P1-10" PowerStation. Each problem is described, followed by one or more possible solutions.

## Chapter Contents

---

<i>Troubleshooting Instructions</i> .....	56
<i>Problems When Starting</i> .....	57
<i>Problems Signaled by PowerSmart</i> .....	60
<i>Problems with Displays</i> .....	62
<i>Problems with Touchscreens</i> .....	63
<i>Problems with Peripheral Devices</i> .....	64

## Troubleshooting Instructions

To use this chapter in the most effective manner, begin with the first solution, and continue until you have solved the problem or exhausted the possible solutions. If you cannot solve the problem yourself, or if you have a problem that is not documented here, do one of the following:

- Contact your CTC Parker Automation distributor
- Check the Support page on the CTC website [www.ctcusa.com](http://www.ctcusa.com)
- Call our Technical Support department at 513-248-1714

Use the following table to find discussions about specific problems.

<b>Problem</b>	<b>Page</b>
<b>Problems When Starting</b>	
System does not start; the display is blank.	57
The RAM test fails, or the total memory installed does not match the total contiguous RAM listed in the display following the RAM test.	58
The system locks up while starting and will not restart.	58
The DOS prompt is displayed instead of the MachineShop Shell main menu.	59
<b>Problems Signaled by PowerSmart</b>	
An error condition exists for a power supply voltage.	60
An error condition exists for a temperature.	60
PowerSmart display shows a COMM ERROR.	61
<b>Problems with Displays</b>	
The top or bottom half of the screen looks dark.	62
After startup, the touchscreen is blank.	62
<b>Problems with Touchscreens</b>	
After startup, the touchscreen does not work properly, or touchscreen calibration is incorrect.	63
After calibrating the touchscreen, it either does not work or does not follow your finger.	63
<b>Problems with Peripheral Devices</b>	
A PS/2 mouse does not work.	64
A keyboard does not work.	64
The Ethernet port does not work.	64
<b>Problems with the Autoexec.bat or Config.sys file</b>	
	65



## Problems When Starting

Some of the most common problems that users encounter with PCs occur when they start their systems. This section discusses problems that may occur during startup.

### System does not start; the display is blank

First, check the power. If the problem still exists, check certain internal components, such as the video cable, SDRAM, and expansion cards.

#### Check the power

1. Turn off the system.
2. Make sure the power cord is firmly plugged into both the system and the power source.
3. Restart the system.

#### Check the video cable, SDRAM, and expansion cards

1. Turn off the system.
2. Disconnect the system from the power source.
3. Open the backplate. See *Opening the System* on page 48 for instructions.
4. Make sure that the video cable is firmly connected.
5. Make sure that the SDRAM modules are firmly seated in their sockets and that the socket latches are fully engaged.
6. Make sure that all expansion cards are firmly seated.
7. Close the system. See *Closing the System* on page 49 for instructions.
8. Reconnect the system to the power source.
9. Restart the system.

**The RAM test fails, or the total memory installed does not match the total contiguous RAM listed in the display following the RAM test**

---

<b>Note</b>	The CPU board contains 32MB of memory. When calculating the total amount of memory for the system, you must add the 32MB of memory on the CPU board to whatever amount of memory you have installed on the SDRAM stick. The maximum amount of memory the P1-10" PowerStation will support is 256 MB.
-------------	--

---

The SDRAM module may not be firmly seated in its socket. Complete the following steps to check that the SDRAM module is properly installed.

1. Turn off the system.
2. Disconnect the system from the power source.
3. Open the backplate. See *Opening the System* on page 48 for instructions.
4. Re-seat the SDRAM module on the CPU card.

Make sure that the module is firmly seated in its socket and that the socket latches are fully engaged.

5. Close the system. See *Closing the System* on page 49 for instructions.
6. Reconnect the system to the power source.
7. Restart the system.

**The system locks up while starting and will not restart**

If MS-DOS will start, you can check the Autoexec.bat and Config.sys files to find the problem. See *Problems with the Autoexec.bat or Config.sys file* on page 65 for instructions.

If MS-DOS will not start, you can try to fix the problem by loading the BIOS default settings.

**Load the BIOS Setup Defaults**

If the system locks up before MS-DOS starts, complete the following steps:

---

<b>Note</b>	This procedure requires a keyboard.
-------------	-------------------------------------

---

1. Turn off the system.
2. Connect a keyboard to the unit.
3. Restart the unit, and press the **F2** key while the system is starting to enter the BIOS setup program.
4. In the Exit menu, select the **Load Setup Defaults** option.

Selecting this option will restore the BIOS settings to their factory default configuration.

5. In the Advanced menu, change the Reset Configuration Data to **Yes**.

When the system restarts, this setting will automatically switch back to No.

6. Save these settings, and exit the setup program.
7. Restart the system.

**The DOS prompt is displayed instead of the MachineShop Shell main menu.**

1. Restart the system.

If the problem still exists, the Autoexec.bat and Config.sys files may be corrupted. You can either overwrite the Autoexec.bat and Config.sys files or modify the existing files. Both of these procedures are explained in detail in *Problems with the Autoexec.bat or Config.sys file* on page 65. If you choose to modify the existing file, continue to step 2.

2. Complete the steps in *Modifying an existing file* on page 65.
3. Verify that the following lines (which load MachineShop Shell) appear at the end of the Autoexec.bat file.

```
CD \CTC
```

```
PSU
```

4. Remove the letters REM if they appear in front of the lines shown in step 3.
5. If you used a DOS text editor to modify the file, you must restart your P1-10" PowerStation in order for your changes to take effect.

## Problems Signaled by PowerSmart

The P1-10" PowerStation comes with the exclusive PowerSmart system monitor that keeps track of the unit's power supply output voltage, internal temperature, and hours of operation. It also displays communication errors by any of PowerSmart's monitoring devices. See *PowerSmart* on page 26 for information about how the PowerSmart utility works.

The following table shows the values monitored by PowerSmart:

Parameter	Nominal Value	Minimum Value	Maximum Value
Internal temperature	N/A	N/A	65°C
3.3V power supply	3.3 VDC	3.0 VDC	3.6 VDC
5V power supply	5.0 VDC	4.75 VDC	5.5 VDC
12V power supply	12.0 VDC	11.5 VDC	12.5 VDC
-5V power supply	-5.0 VDC	-5.5 VDC	-4.75 VDC
-12V power supply	-12.0 VDC	-12.5 VDC	-11.5 VDC

If any of the system's voltage or temperature parameters is out-of-limit, PowerSmart will display the error condition.

The remainder of this section explains how to respond if PowerSmart indicates that any parameters are out of limit.

### An error condition exists for a power supply voltage

1. If PowerSmart indicates low voltage, make sure that any expansion cards installed do not exceed the recommended power supply load limit (see *Appendix A: Electrical Specifications* on page 72 for this parameter).
2. Use a voltmeter to measure the power supply.
3. If the voltmeter confirms the error, contact our Technical Support department at 513-248-1714 about replacing the power supply.

### An error condition exists for a temperature

1. Make sure that any expansion cards installed do not exceed the recommended power supply load limit (see *Appendix A: Electrical Specifications* on page 72 for this parameter).
2. Make sure that the maximum rated ambient temperature for the system has not been exceeded (see *Appendix A: Environmental Specifications* on page 71 for this parameter).

**PowerSmart indicates a COMM ERROR**

1. Check for loose or shorted pins on the PowerSmart peripheral device showing the error.

The devices and their locations are shown in the following table:

Device	Location
Microcontroller (87LPC764)	U38
Peripheral monitor (DS1780)	U41
EEPROM (24C02)	U39

2. Contact our Technical Support department at 513-248-1714 about replacing the device showing the error.

## Problems with Displays

### The top or bottom half of the screen looks dark

One of the backlight bulbs may have burned out. Replace both backlight bulbs. Contact your CTC Parker Automation distributor to order a Backlight Bulb Replacement Kit.

### After startup, the display is blank

This problem could occur if the connection to the power or video cable is interrupted. Complete the following steps to check the power. If the problem still exists, follow the procedure for checking the video cable.

#### Check the power

1. Turn off the system.
2. Make sure the power cord is firmly plugged into both the system and the power source.
3. Restart the system.

#### Check the video cable

1. Turn off the system.
2. Disconnect the system from the power source.
3. Open the backplate. See *Opening the System* on page 48 for instructions.
4. Make sure that the video cable is firmly connected.
5. Close the system. See *Closing the System* on page 49 for instructions.
6. Reconnect the system to the power source.
7. Restart the system.

## Problems with Touchscreens

Each P1-10" PowerStation has a touchscreen display. This section discusses problems that may occur with the touchscreen display.

### **After startup, the touchscreen does not work properly, the touchscreen does not load, or touchscreen calibration is incorrect**

You may need to reconfigure or recalibrate the touchscreen. See *Reconfiguring the Touchscreen Driver* on page 43 and *Recalibrating the Touchscreen* on page 44 for instructions.

### **After calibrating the touchscreen, the touchscreen doesn't work or doesn't follow your finger**

1. Open the unit. See *Opening the System* on page 48 for instructions.
2. Make sure that the touchscreen cable is properly connected.
3. Check the touchscreen cable for damage.
4. Close the unit. See *Closing the System* on page 49 for instructions.
5. If the problem still exists, contact our Technical Support department at 513-248-1714 to order a new touchscreen cable.

## Problems with Peripheral Devices

This section discusses problems that may occur after startup with peripheral devices such as the mouse, the keyboard, and the Ethernet port.

### A PS/2 mouse does not work

1. Make sure that you are using a Microsoft PS/2 mouse rather than a competitor's mouse.

Some manufacturers claim that their PS/2 mice are Microsoft compatible; however, they will not work correctly with the P1-10" PowerStation. Do not use a serial mouse with a serial-to-PS/2 port adapter.

2. Make sure that your mouse is plugged into the PS/2 mouse port.
3. Try using a new PS/2 mouse.

### A keyboard does not work

1. Make sure the keyboard is an AT-compatible keyboard, not an XT keyboard.
2. Make sure that your keyboard is plugged into the PS/2 keyboard port.
3. Try using a new keyboard.

### The Ethernet port does not work

1. Make sure that the Ethernet cable is securely plugged into the Ethernet port.

If the problem still exists, the `Autoexec.bat` and `Config.sys` files may be corrupted. You can either overwrite the `Autoexec.bat` and `Config.sys` files, or modify the existing files. Both of these procedures are explained in detail in *Problems with the Autoexec.bat or Config.sys file* on page 65. If you choose to modify the existing file, continue to step 2.

2. Complete the steps in *Modifying an existing file* on page 65.
3. Verify that the following lines appear in the file:

```
CD \NET  
  
CALL C:\NET\NET.BAT
```

4. Remove the letters `REM` if they appear in front of the lines shown in step 3.
5. If you used a DOS text editor to modify the file, you must restart your system in order for your changes to take effect.



## Problems with the Autoexec.bat or Config.sys file

Many problems with the P1-10" PowerStation stem from a corrupted or modified Autoexec.bat or Config.sys file. This section describes how to overwrite a corrupted file with a clean copy of the file or modify an existing file.

Copies of the Autoexec.ctc and Config.ctc files are included in the system files that were pre-formatted on your CompactFlash card. If your CompactFlash card has become corrupted or the files are not readable, you can restore all system files using the FlashBack utility. See *Restoring a CompactFlash Card* on page 40 for complete instructions.

### Determining system requirements

If your DOS system has a text editor, you can modify the Autoexec.bat or Config.sys file directly on your P1-10" PowerStation.

However, some DOS systems, such as the one installed with the system files that were shipped with your system, do not support text editing. In this case, you will need one of the following in order to modify a corrupted Autoexec.bat or Config.sys file:

- A personal desktop computer with a SanDisk ImageMate (CompactFlash reader/writer) installed.
- A laptop with a PCMCIA-to-CompactFlash adapter.

---

**Note** You can purchase both a SanDisk ImageMate and a PCMCIA-to-CompactFlash adapter from your CTC Parker Automation distributor.

---

### Overwriting a corrupted file

If you suspect a problem with the Autoexec.bat or Config.sys file complete the following steps:

1. Create a backup copy of your current file using the **DOS copy** command.
2. Overwrite the suspect file with the clean file that came on your CompactFlash card. You can locate this file in the ... \ctc\ directory. For example, if the Autoexec.bat file is suspect, type the following commands at the **c:\** prompt:

```
copy autoexec.bat autoexec.old
copy \ctc\autoexec.ctc autoexec.bat
```

3. Restart the system.

### Modifying an existing file

If you have a DOS text editor installed on your P1-10" PowerStation (see *Determining system requirements* on page 65 for more information), complete the following steps to modify an Autoexec.bat or Config.sys file:

1. Turn off the system.
2. Connect a keyboard to the unit if one isn't already connected.
3. Restart the system.
4. When the message Starting MS-DOS appears, press the **F8** key.

The system will step through the Autoexec.bat and Config.sys files line-by-line.

If you do not have a DOS text editor installed on your P1-10" PowerStation (see *Determining system requirements* on page 65 for more information), complete the following steps to modify an Autoexec.bat or Config.sys file:

1. Shut down your P1-10" PowerStation.
2. Eject the CompactFlash card.
3. Insert the CompactFlash card into the SanDisk ImageMate of a personal computer or PCMCIA slot of a laptop.
4. Using Windows Explorer, open the Autoexec.bat or Config.sys file from the root directory of your CompactFlash drive.

You can now modify your Autoexec.bat or Config.sys file.

### Verifying the Autoexec.bat file

The lines shown in the following table must appear in the PowerStation's Autoexec.bat file for the unit to operate properly. If you suspect that your Autoexec.bat file is corrupted, ensure that it includes the command lines shown in the left-hand column of the following table.

Command Line Parameters	Description
PATH C: \; C: \DOS; C: \CTC	Sets up the default DOS path.
CD \CTC IF EXIST C: \CTC\MOUSE.INI DEL C: \CTC\MOUSE.INI	Required for MachineShop Shell to detect a mouse in some situations.
LH C: \CTC\MOUSE  :ITSAP1	If a mouse is connected, installs the mouse and creates a new MOUSE.INI file.
SET TOUCH_PATH=C: \TOUCH CALL %TOUCH_PATH% \TCH INIT.BAT	Initializes the touchscreen drivers.
*SET INTERACT=C: \INTERACT	Sets the Interact path.
*SET INTERACT_FILES=C: \INTERACT\APPFILS	Sets the application path for Interact.
*SET INTERACT_STARTUP= C: \STARTUP	Sets up Interact startup variables.
CD \NET LH C: \NET\TCPIP	Loads network drivers—Novell and/or TCPIP stack.
IF NOT EXIST C: \STARTUP\NUL.EXT MD C: \STARTUP CD \STARTUP IF EXIST C: \STARTUP\ AUTOEXEC.BAT CALL C: \STARTUP\AUTOEXEC.BAT	Calls the second Autoexec.bat file if the line is contained within a project file.
CD \CTC PSU	Starts the MachineShop Shell.

\* These command lines are unnecessary on units without Interact.

# APPENDIX A: SPECIFICATIONS

This appendix lists specifications for the P1-10” PowerStation.

## Contents

---

<i>Physical Specifications</i> .....	68
<i>Recommended SDRAM Manufacturers</i> .....	69
<i>Operating Systems Supported</i> .....	69
<i>Display Specifications</i> .....	70
<i>Environmental Specifications</i> .....	71
<i>Electrical Specifications</i> .....	72
<i>Testing Specifications</i> .....	72
<i>Faceplate Chemical Resistance</i> .....	73
<i>Agency Approvals</i> .....	74

## Physical Specifications

This section describes the physical specifications of the P1-10" PowerStation.

Category	Specifications
Dimensions (H x W x D)	See dimensional drawings in <b>Appendix B: Dimensional Drawings</b> .
Weight	13.9 lbs.
Processor	Intel® Pentium 166MHz, 66MHz host bus frequency
Memory	32MB SDRAM (4 chips) is soldered on the CPU card. In addition, one DIMM socket supports up to 256MB of SDRAM.
Storage	One external on-board CompactFlash (CF) slot with card ejector
Peripheral interfaces	<ul style="list-style-type: none"> <li>• Three 16550 serial ports               <ul style="list-style-type: none"> <li>◦ Two 9-pin serial RS-232 ports</li> <li>◦ One 9-pin RS-232/422/485 configurable port</li> </ul> </li> <li>• One internal for the touchscreen controller</li> <li>• One 25-pin bi-directional parallel port, supports SPP, EPP, and ECP</li> <li>• Two PS/2 ports               <ul style="list-style-type: none"> <li>◦ Keyboard</li> <li>◦ Mouse</li> </ul> </li> <li>• One RJ45 Ethernet port, 10Base-T/100Base-TX (See "Ethernet Controller" below)</li> <li>• On-board resistive touchscreen controller</li> </ul>
Ethernet Controller	<ul style="list-style-type: none"> <li>• Intel 82559 PCI 10BASE-T/100BASE-TX Interface Ethernet controller</li> <li>• RJ45 interface</li> <li>• Integrated IEEE 802.3 10BASE-T and 100BASE-TX compatible PHY</li> <li>• System Management Bus (SMB) support for advanced management support</li> <li>• PCI power management specifications compliance</li> <li>• Full duplex support at both 10 and 100 Mbps operation</li> <li>• IEEE 802.3u auto-negotiation support</li> <li>• 3K Transmit FIFO and 3K Receive FIFO</li> <li>• Back-to-back transmission support with minimum interframe spacing</li> <li>• IEEE 802.3x 100BASE-TX Flow Control support</li> </ul>
Video	<ul style="list-style-type: none"> <li>• Intel, CHIPS 69000 HiQVideo™ Accelerator</li> <li>• 2MB of high-speed SDRAM on chip-frame buffer</li> </ul>
Touchscreen	<ul style="list-style-type: none"> <li>• A serial touchscreen controller is used to interface to the Touchscreen</li> <li>• The touchscreen is connected to the ISA bus through the 16C552 UART, designated as COM3</li> <li>• I/O resources for the touchscreen are BIOS</li> <li>• The IRQ choices are IRQ3, IRQ4, IRQ9, IRQ11</li> </ul>

Category	Specifications
BIOS	<p>Phoenix BIOS is located in the 256K boot-block FLASH EPROM. Standard features include:</p> <ul style="list-style-type: none"> <li>◦ FLASH/EPROM-based setup utility</li> <li>◦ Power-On Self-Test (POST)</li> <li>◦ Password protection</li> <li>◦ Advanced Power Management</li> <li>◦ System plug and play support</li> </ul>
Additional Features	<ul style="list-style-type: none"> <li>• Real-time clock with battery backup</li> <li>• APC (Advanced Power Supply) control</li> <li>• Integrated 24VDC-input power supply</li> <li>• CTC Parker's software security key socket</li> <li>• CTC Parker's PowerSmart hardware support</li> <li>• "Sticky IDE" feature</li> <li>• Beeper</li> <li>• Watchdog Timer <ul style="list-style-type: none"> <li>◦ Includes a software-enabled/disabled watchdog timer</li> <li>◦ Generates a system reset when triggered</li> <li>◦ Timeout interval ranges from 1 to 62 seconds</li> <li>◦ Can be set by writing an I/O port address</li> </ul> </li> </ul>

## Recommended SDRAM Manufacturers

The following SDRAM manufacturers are recommended by CTC Parker Automation:

Available Sizes	Manufacturer	Product Number
256MB	Hyundai	HYM71V653201
256MB	Toshiba	THMY6432G1EG-80
128MB	Hyundai	HYM7V651601BTRG-10S
128MB	Micron	MT8LSDT1664AB-10EB1
128MB	SEC	KMM374S1623BT-GLQ
64MB	Hyundai	HYM7V65801BTRG-10S
64MB	Micron	MT4LSDT864AG-10EB1
64MB	Toshiba	THMY6480F1BEG-80
32MB	Hyundai	HYM7V65401BTRG-10S
32MB	Micron	MT4LSDT464AG-10EC6
32MB	SEC	KMM374S403CT-GL
32MB	SEC	KMM374S823BT-GLQ

## Operating Systems Supported

The P1-10" supports the MS-DOS 6.xx operating system.

## Display Specifications

This section describes the display options and specifications of the P1-10" PowerStation.

### Display Options

The P1-10" PowerStation comes with the display options shown in the following table. Each display can be ordered with or without a touchscreen, and each color display can show up to 262,144 colors.

PowerStation	Display Size	Resolution	Color	Type
P1-10"	9.4"	VGA (640 x 480)	Mono	LCD
	10.4"	VGA (640 x 480)	Color	TFT
	10.4"	VGA (640 x 480)	Bright color	TFT

### Brightness, and Backlight Lifetime

The following table describes the brightness specifications and the backlight lifetime of the P1-10" PowerStation. Backlights are field-replaceable; you can order a backlight kit from CTC Parker Automation at 513-831-2340. For more information, see *Replacing Components* on page 46.

Category	Display Type	Specifications
Brightness	9.4" Mono	110 nits
	10.4" TFT Color	200 nits
	10.4" Bright TFT Color	350 nits
Backlight lifetime	9.4" Mono	10,000 hours
	10.4" TFT Color	50,000 hours
	10.4" Bright TFT Color	50,000 hours

## Environmental Specifications

The table below describes the specifications of the area where the system will be mounted.



### Important

Limit the system's exposure to adverse conditions, such as dust, oil, moisture, and corrosive vapors in order to minimize maintenance and repair costs.

Remember that the temperature within a protective enclosure is generally higher than the external temperature. Thus, if the system is operating inside an enclosure, at temperature levels above its rated ambient temperature, you must cool the enclosure.

Category	Specifications
Operating temperature	41° to 122° F (5° to 50° C) ambient air temperature
Storage temperature	-4°F to 158°F (-20° to 70° C)
Relative humidity	5% to 95% non-condensing
Altitude	-200ft. to 10,000ft. (-60.96m to 3,048m)
Shock rating	10g, 11ms operating 30g, 11ms non-operating
Vibration rating	1g rms from 10 to 500Hz operating
Faceplate designed for	Type 4/4X environment
	Note The unit is only rated for a 4/4X environment if it is mounted in an enclosure that is rated NEMA 4/4X.

## Electrical Specifications

The model P1-10" PowerStation accepts DC input only. To apply AC power, you must use an AC adapter. You can purchase an AC adapter from CTC Parker Automation at 513-831-2340.



### Important

The system's power supply automatically detects the input voltage level and adjusts accordingly. However, always use reliable sources of power, and isolate all communication cables from power lines to enhance noise immunity.

Electrical specifications for the system are listed in the table below.

Category	Unit Specifications
Input voltage	24VDC nominal @ 3.25A Input voltage range: 18VDC-28VDC
Fuse type	250VAC Littelfuse, part #216.315, field-replaceable 5A max. overcurrent protection
Expansion slots	Voltage and total current available for expansion cards are as follows: 3.3VDC @ 1A 5VDC @ 1.5A 12VDC @ 0.5A -5VDC @ 0.075A -12VDC @ 0.15A

## Testing Specifications

The following table describes the criteria used for testing the P1-10" PowerStation.

Testing Criteria	Classification
Showering arc	NEMA showering arc
Surge withstanding capacitance	EN61000-4-5
ESD requirements	EN61000-4-2
Operating temperature	IEC 68-2-1
Electrical fast transient	EN61000-4-4
European Harmonized EAC Standards	EN50082-2, EN55011
Operating vibration	IEC 68-2-6
Mechanical shock	IEC 68-2-27
Random vibration	MIL-STD-810D



## Faceplate Chemical Resistance

The system's faceplate can resist the chemicals listed below, with no visible effect.

Acetone	Sulfuric Acid 10%	Motor oil
MEK	Hydrochloric Acid 10%	Gasoline
Toluene	Acetic Acid 10%	Machine oil
Methylene Chloride	Phosphoric Acid	Salad oil
Isopropyl Alcohol	Sodium Hydroxide 10%	Silicone
Xylene	Carbon Tetrachloride	Silicone grease G31
Hexane	Potassium Hydroxide	Kerosene
Butyl Cellosolve	Ammonia water 10%	Gas oil
Cyclohexanone	Sodium Chloride 26%	Silicone oil
Trichloroethylene	Zinc Chloride 81%	Engine oil
Ethanol	Cottonseed oil	Cleanser
Methanol	Glycerin	
Nitric Acid 10%	Grease	



### Important

Sustained exposure to brake fluid or Gunk® brand degreaser can cause damage to monitor materials.

All system surfaces exposed outside of an enclosure are resistive to the following chemicals:

- Commercial glass cleaners
- Ammonia (10% dilute solution)
- Motor oil
- Hydraulic fluid
- Diesel fuel
- Gasoline (leaded, unleaded)
- Silicone-based lubricant
- Alcohol (ethyl, methyl)
- Automatic transmission fluid

## Agency Approvals

All P1-10" PowerStation workstations are available with the following combinations of agency approvals:

Agency Approvals			
UL	CUL		
UL	CUL	CE	
UL	CUL	Class 1 Div 2	
UL	CUL	CE	Class 1 Div 2

# APPENDIX B: DIMENSIONAL DRAWINGS

This appendix contains dimensional drawings that you can use when installing the P1-10” PowerStation. To view the drawings in .dxf format or to view a 3-D model of the P1-10” PowerStation, consult the P1 PowerStation Documentation CD that came with your system.

## Contents

---

<i>Front View: Monitor</i> .....	76
<i>Left Side View: Components</i> .....	77
<i>Back View: Components</i> .....	78
<i>Cutout</i> .....	79

# Model: P1-10"

## Front View: Monitor

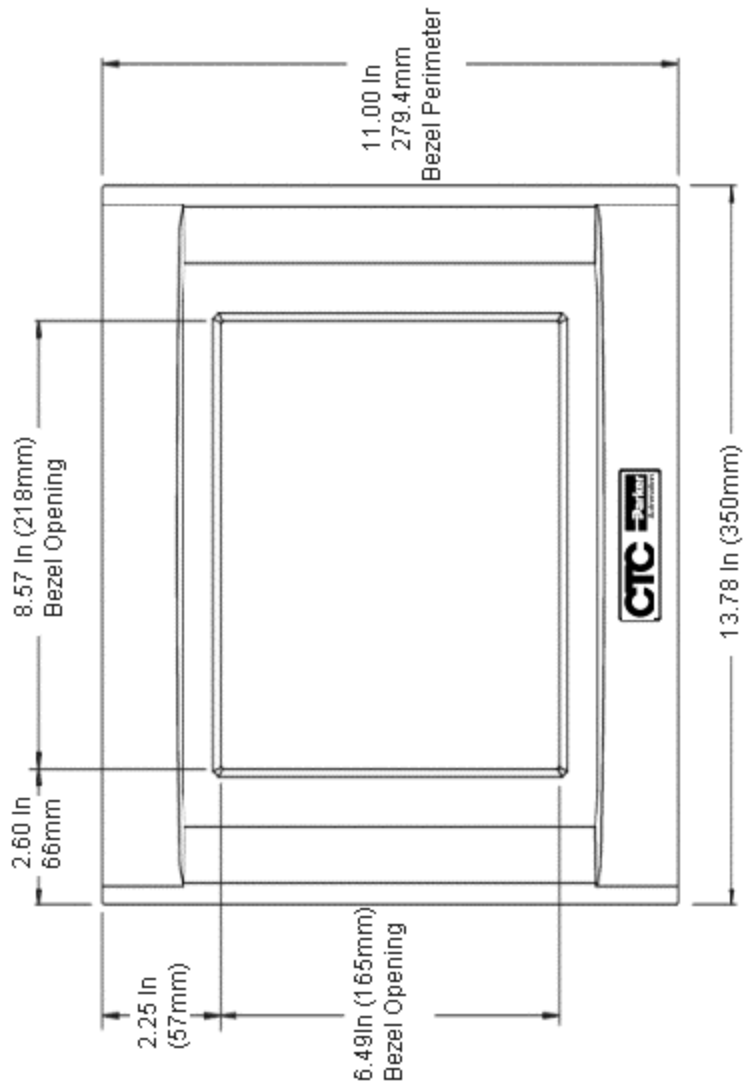

# Left Side View: Components

(Model: P1-10")

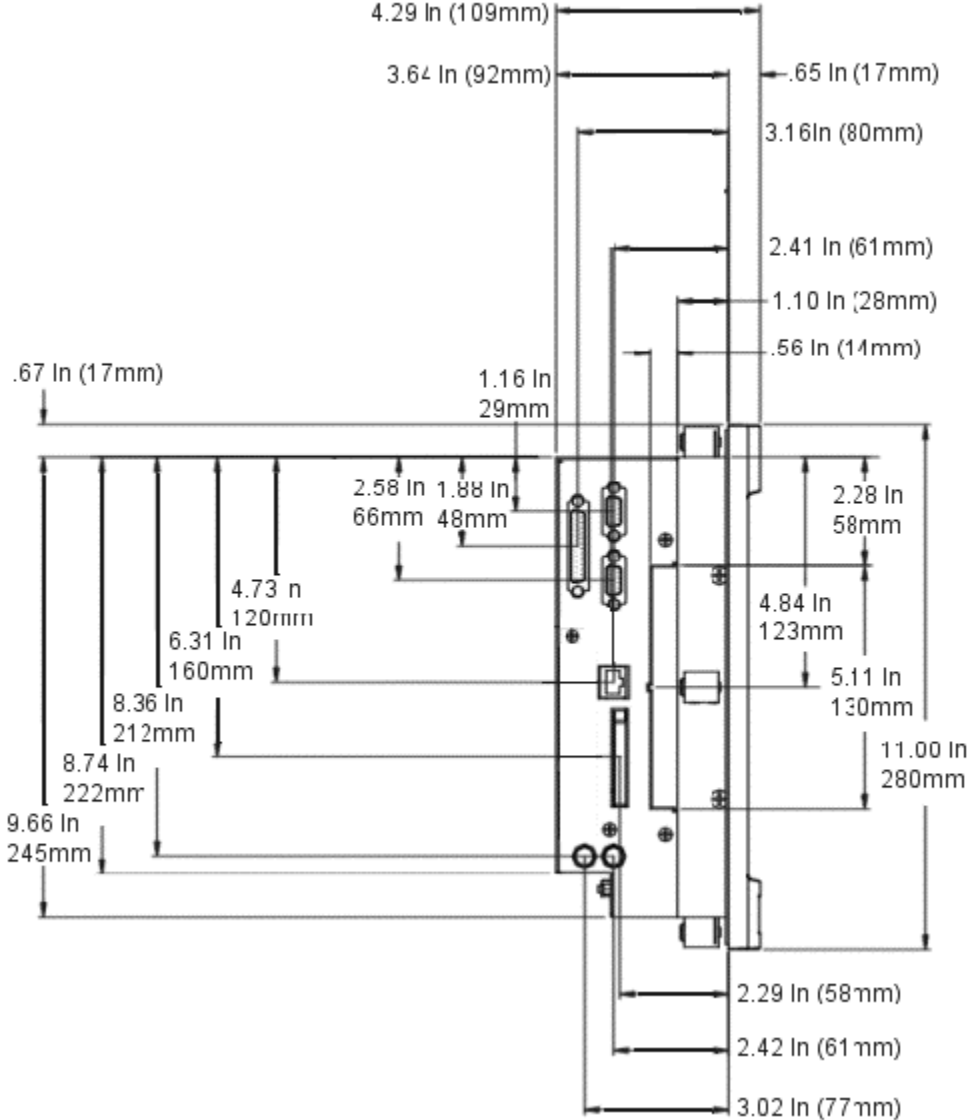

## Back View: Components

(Model: P1-10")

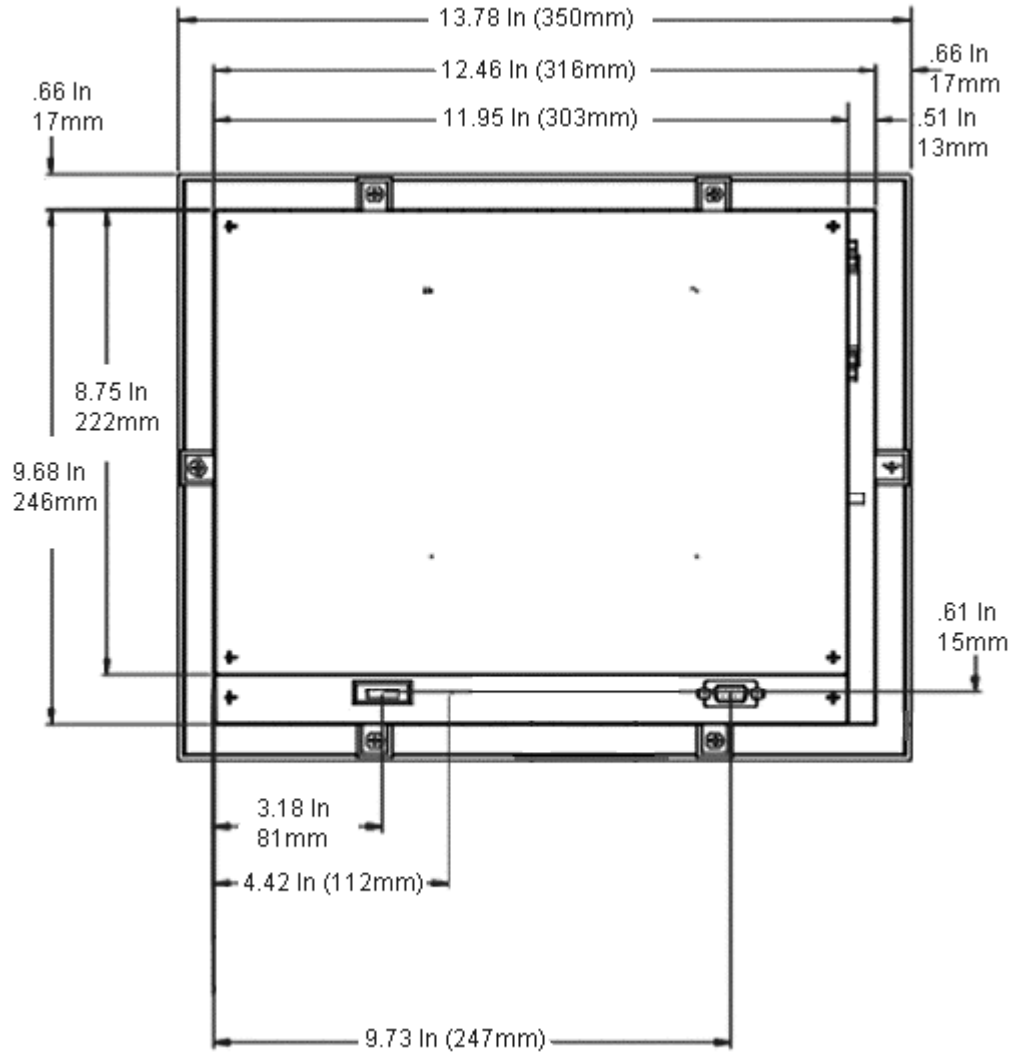

# Cutout

(Model: P1-10")

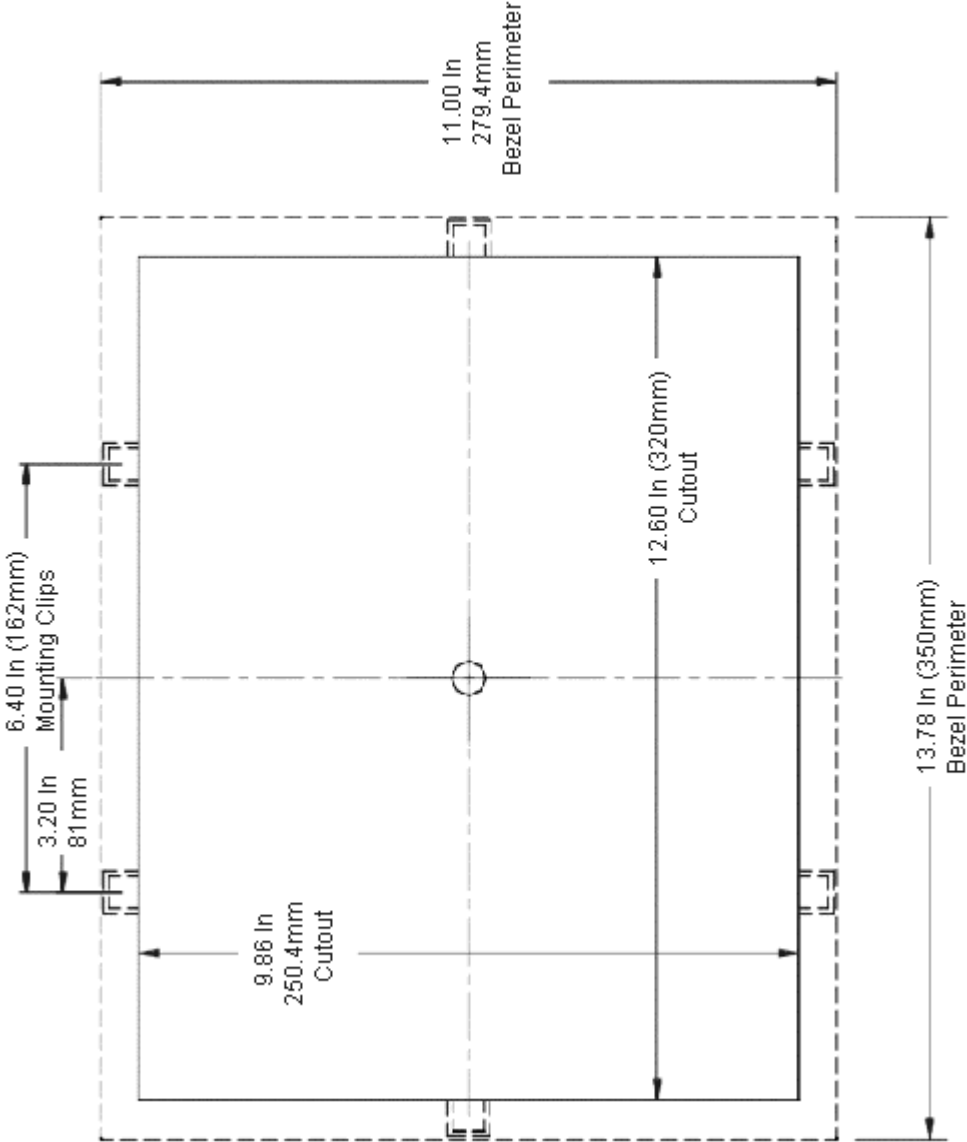

---

# INDEX

## A

Agency Approvals, 74  
Application Engineering Services, 11  
Autoexec.bat File  
    Troubleshoot, 65

## B

Backlight bulbs, 46  
Battery, 25  
    Field Replaceable, 46  
    Lithium, 25  
BIOS, 18  
    Memory Map, 29  
    Settings, 18, 37, 38  
        Default, 39  
Bus interfaces, 17

## C

CD-ROM  
    Field Replaceable, 46  
CF. *See* CompactFlash  
Class I, Division 2 Guidelines, 31  
Cleaning the Display Screen, 42  
Closing the System, 49  
CMOS settings, 52  
COM1, 21, 22, 28, 51  
COM2, 17, 21, 22, 28, 50, 51  
COM3, 21, 22, 28  
CompactFlash, 14, 19, 68  
    Location, 19  
    Memory, 29  
    Reformat, 40, 41  
    Remove, 20  
    Replace, 20  
    Using, 19, 40  
Config.sys File  
    Backup copy, 65  
    Troubleshoot, 65  
Configurable jumpers, 17  
Configuring Serial Ports, 38

Copyright, 2  
CPU, 21, 26, 29, 50  
    Battery, 25  
    Diagram, 17  
    Jumpers, 50  
    Fuse, 25  
    Value  
        Features, 15  
        Specifications, 68  
    Voltage, 24  
    Watchdog Timer, 26  
Customer Support, 10.  
    Consulting Services, 11  
    Product Support Program, 11  
    Training, 11

## D

Dimensional Drawings, 75  
Displays, 18  
    Problems, 56, 62  
    Specifications, 70  
Drives  
    Access, 32  
    CF, 19

## E

Electrical Guidelines, 31  
Electrical Specifications, 72  
Enclosure Guidelines, 32  
Environmental Guidelines, 31  
Environmental Specifications, 71  
EPROM, 18, 61, 69  
ESD Precautions, 47  
Ethernet Port, 24  
    Jumpers, 50, 51  
    Pinout Data, 24  
    Specifications, 68  
    Troubleshoot, 64  
Expansion Slots, 27  
    Max. Depth, 27  
    Specifications, 72



## F

- Faceplate, 31
  - Chemical Resistance, 73
- FLASH memory, 18
- Floppy Drive
  - Field Replaceable, 46
- Fuse, 25, 72
  - Field Replaceable, 46

## H

Hard Drive. *See* CompactFlash.

## I

- I/O addresses, 27
- IRQ
  - Table, 28
  - Touchscreen, 43, 50
- ISO Symbols, 9

## J

- Jumpers
  - Change Settings, 50
  - Diagram, 50

## M

- Memory, 29, 68. *See* SDRAM
  - Modules, 29
- Mounting the System, 33
- MS-DOS, 34
  - Restore on CF, 40

## N

- Null Modem, 23

## O

- Opening and Closing the System, 47

## P

- Parallel Port, 18, 21, 23, 27, 28, 68
  - Pinout Data, 23
  - Printer, 23

- Peripheral Devices, 26, 64
- Physical Specifications
  - Value Model, 68
- Pinout Data
  - Ethernet Port, 24
  - Parallel Port, 23
  - PS/2 Ports, 24
- Power Supply, 24, 69
- PowerSmart, 26, 56, 60, 61, 69
- Problems when starting, 56, 57
- Problems with peripheral devices, 56
- Processor, 17, 68
- Product Support Program (PSP), 12
- PS/2 Ports, 21, 24, 68

## R

- RAM, 18, 56. *See also* SDRAM
- Recalibrating the Touchscreen, 44
- Reconfiguring the Touchscreen Driver, 43
- Replacement components, 46
- Replacing Components, 46
- Reverse Polarity Damage, 24
- RS-232, 21, 22, 51, 68
- RS-422, 21, 22, 51
- RS-485, 21, 22, 51
- Runtime, 29

## S

- SDRAM, 29, 46, 67, 68, 69
  - Field Replaceable, 46
- Selecting a Location, 31
- serial ports, 18, 38, 51, 68
- Serial Ports, 21, 23, 38, 43
- Standards
  - Documentation, 9
  - ISO Symbols, 9

## T

- Technical Support, 10
  - E-mail, 10
  - Fax, 10
  - Phone Number, 10
  - Web, 10
- Temperature Guidelines, 32
- Testing Specifications, 72
- Touchscreen, 43, 44, 45, 46, 63, 68
  - Field Replaceable, 46
  - Recalibrate, 44

Training, 11  
Troubleshooting, 10, 56

## **W**

Warranty, 2  
Watchdog Timer, 26, 27, 69  
Windows 2000, 29