

PARKER HMI and Visualization Products

Adapter Plate Installation Guide

To migrate from IPX/IPC or EPX2 10 & 15" cutouts to the latest IX or PCA

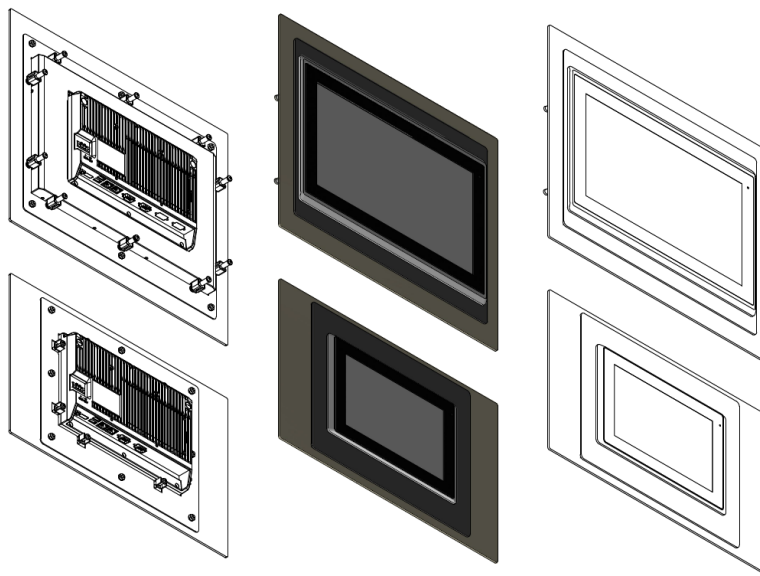

Effective: May 2016

Version 1.0

© 2016 Parker Hannifin Corporation
All Rights Reserved

About Parker Adapter Plates 3

Installation Instructions..... 4

Mechanical Drawings 5

About Parker Adapter Plates

To make the mechanical transition as easy as possible, Parker has developed 4:3 to 16:9 adapter plates to work for some sizes and some models. These plates require no changes in the users' current IPX/IPC or EPX2 cutout and allow the new IX or PCA series to fit within the same mechanical constraints.

The transition plate system consists of two steel plates. The first steel plate containing the threaded studs, is set within the legacy IPX/IPC and EPX2 cutout on the outside of the customer enclosure. The threaded studs provide the alignment required to ensure proper installation and centering. The second plate is attached to the first from the inside of the enclosure. When compressed with the included lock nuts, the two plates provide a compression force providing a seal and secure hold. The new IX or PCA then mounts into the assembled transition plate system using the same installation process and clamps as if it were mounting into a new standard enclosure cutout.

The outside-facing steel plate is colored ANSI 61 gray to match Hoffman and many other enclosure brands. If a different paint color is required, please contact Parker.

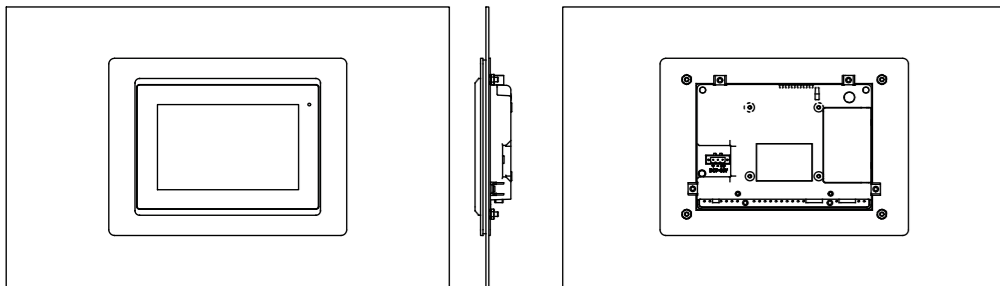

IPX/IPC Size	EPX2 Size	IX/PCA Model	Conversion Plate Part #
10"	10"	IX/PCA-010-...	ADPT-010-600
15"	15"	IX/PCA-015-...	ADPT-015-600

The Parker adapter plates were designed and tested up to IP65 standards but are not officially certified in order to keep the cost of installation of the adapter plate as low as possible and to pass those savings onto the customer.

Installation Instructions

1. Place the adapter plate that has a gasket and studs into the cut-out from the outside, using the studs as a guide.
2. Install the flat back plate from the inside of the cut-out.
3. Center the gasket on the cut-out.
4. Torque nuts to the appropriate torque value (8.7 in-lbs for the 10.1 and 15.6 inch displays).
5. Torque nuts again after the first tightening to ensure that minimum torque has been achieved.
6. Install display through cut-out.
7. Center the display in the cut-out.
8. Attach clamps into display (move screws up if there is not enough clearance for the screw).
9. Tighten screws to 8.7 in-lb torque (min).
10. Torque screws again after the first tightening to ensure that minimum torque has been achieved.

Mechanical Drawings

ADPT-010-600

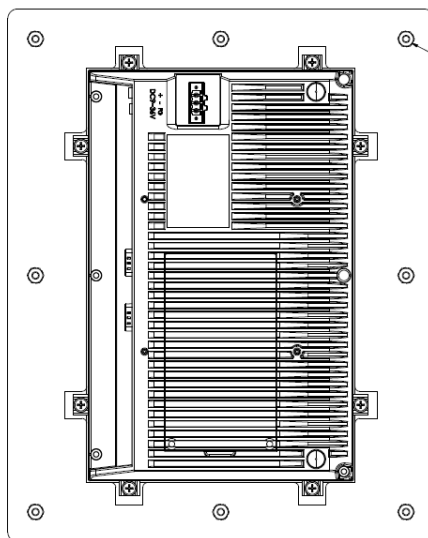
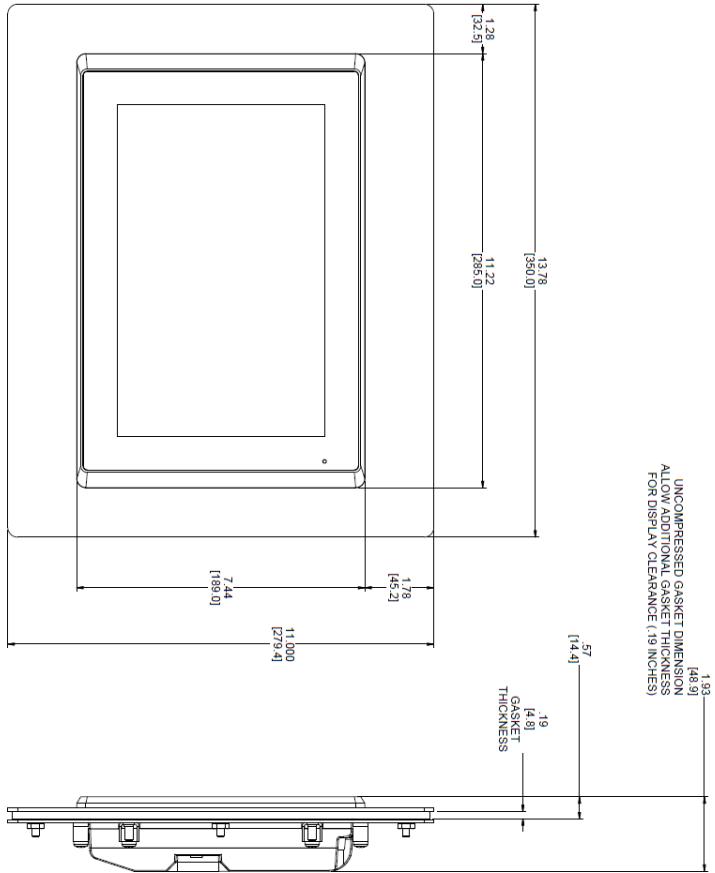

16x TORQUE ALL SCREWS AND NUTS TO 8.7 IN.LBS.MM.
RE-TORQUE ALL SCREWS AND NUTS A SECOND TIME
TO ENSURE THAT MINIMUM TORQUE IS ESTABLISHED.

ADPT-015-600

