

PPC-315 EHL

15" Fanless Panel PC with Intel® Celeron® J6412 Processor



Features

- Industrial-grade 15" XGA TFT LCD with 70K backlight lifetime
- Durable true-flat touchscreen with 5-wire resistive/projected capacitive touch control
- Intel® Celeron® J6412 quad-core, 2.0 GHz, processor
- Up to 32 GB DDR4 SDRAM
- 1 x RS-232, 1 x RS-232/422/485, 2 x USB 2.0, and 2 x USB 3.1
- Compact, fanless design with solid aluminum alloy enclosure and IP66-rated front panel
- Supports E-key for wireless module
- Supports expansion via M.2 slot
- Supports Windows Embedded Linux and Android OS
- Supports VESA 75 x 75 mounting holes
- Dual 2.5GBASE-T Ethernet Supports Time-Sensitive Network(TSN) technology



Introduction

PPC-315 EHL is an industrial panel PC with 15" XGA LCD, powered by Intel Celeron quad core J6412 processor. With aesthetic aluminum alloy enclosure, PPC-315 EHL ensures fanless reliability and easy maintenance in diverse industrial applications. Moreover, it provides more faster and flexible connection via 2 x 2.5G Ethernet port, 2 x USB 3.1 and 1 x Type C (USB only). The PPC-315 EHL is ideal for MES, processing and general industrial equipment integration.

Specifications

		PPC-315-RJ60A	PPC-315-PJ60A
System	CPU	Intel® Celeron® J6412 quad core	
	Frequency	2.0 GHz	
	L2 Cache	1.5 MB	
	Memory	1 x SDRAM DDR4 3200 MHz (max. 32G)	
	Storage	1 x 2.5" SATA bay (optional: requires a bracket module for installation) 1 x M.2 slot: M key for storage (SATA only, 2242 & 2280)	
	Network (LAN)	2 x 10/100/1000/2500 Mbps Ethernet (Intel I225-LM)	
	I/O	2 x Serial ports: 1 x RS-232, 1x RS-232/422/485 (Adjustable through BIOS) 2 x USB 2.0, 2 x USB 3.1 1 x Type C (USB only) 1 x HDMI1.4 1 x TPM2.0	
	Expansion	1 x M.2 2230 E-key for wireless card	
Watchdog Timer	255 timer levels, set up by software		
Physical Characteristics	Dimensions	392 x 314 x 55 mm (15.4 x 12.4 x 2.2 in)	
	Weight	5 kg (11.02 lb)	
OS Support	OS Support	Microsoft® Windows 10 IOT LTSC(64-bit), Win11, Linux, Android	
Power Consumption	Input Voltage	12 ~ 30 V _{DC}	
	Power Consumption	45W (Burn-in test 8.1 in Windows 10, 64-bit)	
LCD	Display Type	15" TFT LCD (LED backlight)	
	Resolution	1024 x 768	
	Viewing Angle	80 (left), 80 (right), 88 (up), 88 (down)	
	Luminance (cd/m ²)	300	
	Contrast Ratio	2000	
	Backlight Lifetime	70,000 hr (min.)	
Touchscreen	Touch Type	5-wire resistive touch	Projected Capacitive Multi-touch
	Light Transmission	80±5% at 550 nm wavelength	88±2%
	Controller	USB interface	USB interface
	Durability (Touches)	Greater than 35 million touches in one location without failure	Cover glass > 7H
Environment	Operating Temperature	-10 ~ 50°C (14 ~ 122°F)	
	Storage Temperature	-20 ~ 60 °C (-4 ~ 140 °F)	
	Relative Humidity	95% @ 40 °C (non-condensing)	
	Shock	Operating 10 G peak acceleration (11 ms duration), follow IEC 60068-2-27	
	Vibration	Operating Random Vibration Test 5 ~ 500Hz, 2Grms @with SSD, follow IEC 60068-2-64	
	EMC	CE, FCC Class B, BSMI, UKCA, VCCI	
	Safety	CB, CCC, UL, UKCA	
Front Panel Protection	IP66 compliant		

Dimensions

Unit: mm

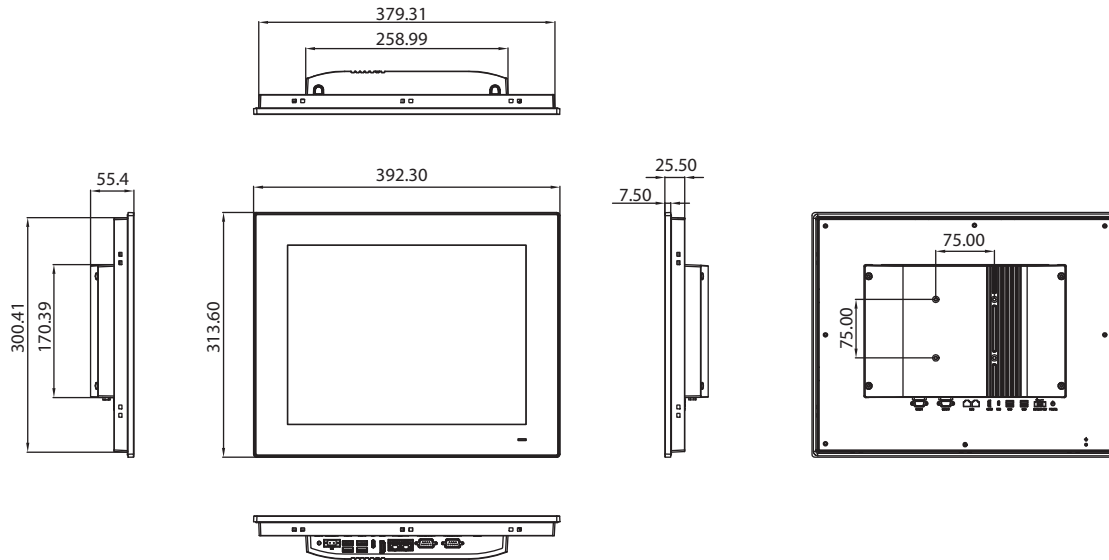

Panel Cutout Dimensions: 382 x 303 mm (15.03 x 11.92 in)

Ordering Information

Part Number	Description
PPC-315-RJ60A	15" PPC w/Intel J6412, Resistive
PPC-315-PJ60A	15" PPC w/Intel J6412, P-Cap
98R3P300020	PPC-300 EHL 2.5" SSD bracket module
96PSA-A90W190T-3	Power adapter 100-240V 90W 19V
PPC-WLAN-D2	M.2, WiFi6 +BT5.2, 2T2R, w/Antenna
PPC-ARM-A03	ARM VESA Standard (A-CLEVER) for PPC series
PPC-174T-WL-MTE	Wall mount kit for PPC series
PPC-Stand-A1E	Stand for PPC series
1700001524	Power cord 3P UL 10A 125V 1.8M
170203183C	Power cord 3P Europe (WS-010+083) 183cm
1700008921	Power cord 3P/3P 1.8M PSE
96CB-POWER-B-1.8MB	Power cord 3P CCC(China) 1.8M
98R3P300010	PPC-300 RFID Read only 13.56MHz&125k

I/O View

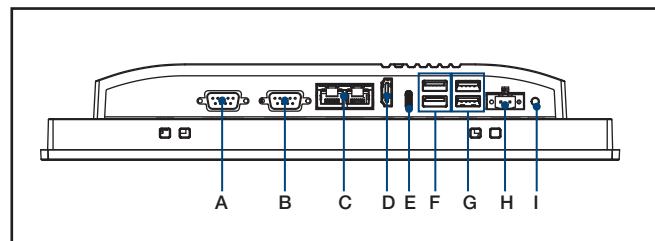

- A. 1 x RS-232
- B. 1 x RS-232/422/485
- C. 2 x LAN
- D. 1 x HDMI
- E. 1 x Type C (USB only)
- F. 2 x USB 3.1
- G. 2 x USB 2.0
- H. DC-In
- I. Power Switch

Please note: If some optional modules are offered with the system, additional system certificates may be required in certain regions/countries. Please contact Advantech for certificate compliance.