

SIEMENS

SIMATIC

Industrial Monitors Industrial Flat Panel IFP1500, IFP1900, IFP2200

Operating Instructions

Preface

Overview

1

Safety information

2

Installing and connecting the device

3

Commissioning the device

4

Operating the device

5

Maintaining and servicing your device

6

Technical information

7

Technical Support

A



List of abbreviations

B

Legal information

Warning notice system

This manual contains notices you have to observe in order to ensure your personal safety, as well as to prevent damage to property. The notices referring to your personal safety are highlighted in the manual by a safety alert symbol, notices referring only to property damage have no safety alert symbol. These notices shown below are graded according to the degree of danger.

 DANGER
indicates that death or severe personal injury will result if proper precautions are not taken.
 WARNING
indicates that death or severe personal injury may result if proper precautions are not taken.
 CAUTION
indicates that minor personal injury can result if proper precautions are not taken.
NOTICE
indicates that property damage can result if proper precautions are not taken.

If more than one degree of danger is present, the warning notice representing the highest degree of danger will be used. A notice warning of injury to persons with a safety alert symbol may also include a warning relating to property damage.

Qualified Personnel

The product/system described in this documentation may be operated only by **personnel qualified** for the specific task in accordance with the relevant documentation, in particular its warning notices and safety instructions. Qualified personnel are those who, based on their training and experience, are capable of identifying risks and avoiding potential hazards when working with these products/systems.

Proper use of Siemens products

Note the following:

 WARNING
Siemens products may only be used for the applications described in the catalog and in the relevant technical documentation. If products and components from other manufacturers are used, these must be recommended or approved by Siemens. Proper transport, storage, installation, assembly, commissioning, operation and maintenance are required to ensure that the products operate safely and without any problems. The permissible ambient conditions must be complied with. The information in the relevant documentation must be observed.

Trademarks

All names identified by ® are registered trademarks of Siemens AG. The remaining trademarks in this publication may be trademarks whose use by third parties for their own purposes could violate the rights of the owner.

Disclaimer of Liability

We have reviewed the contents of this publication to ensure consistency with the hardware and software described. Since variance cannot be precluded entirely, we cannot guarantee full consistency. However, the information in this publication is reviewed regularly and any necessary corrections are included in subsequent editions.

Preface

These operating instructions contain all the information you need for commissioning and operation of the SIMATIC Industrial Flat Panel IFP.

It is intended both for programming and testing personnel who commission the device and connect it with other units (automation systems, programming devices), as well as for service and maintenance personnel who install add-ons or carry out fault/error analyses.

Basic knowledge required

A solid background in personal computers and Microsoft operating systems is required to understand this manual. General knowledge in the field automation control engineering is recommended.

Scope of the operating instructions

These operating instructions apply to all IFP1500, IFP1900 and IFP2200 Industrial Flat Panels with the order numbers 6AV7863-....

Scope of this documentation

The SIMATIC Industrial Flat Panel is supplied with the following documents:

- In printed form: Quick Install Guide SIMATIC IFP1500, IFP1900, IFP2200, Installation and Commissioning Instructions
- Electronically as PDF file on the "Documentation and Drivers" CD/DVD:
 - SIMATIC IFP1500, IFP1900, IFP2200 Operating Instructions
 - Operating Manual SIMATIC IPC Wizard

You can find the operating manual in the IPC Wizard installation directory after installing the IPC Wizard.

Conventions

In these operating instructions, the SIMATIC IFP is also referred to as "Flat Panel" or "device".

At some places in these operating instructions, the general term "Windows Embedded Standard" is used to refer to "Windows Embedded Standard 2009" and "Windows Embedded Standard 7". "Windows 7" is used as an abbreviation for "Windows 7 Ultimate".

A touch device generally refers to a device with a touch screen, as opposed to a pure "display device". Touch screen is the general term for a capacitive multi-touch screen and resistive single touch screen.

Figures

This manual contains figures of the described devices. The supplied device may differ in some details from the figures. Within some of the figures, one device is used to represent all Industrial Flat Panels.

History

The following earlier release versions of these operating instructions have been published:

Edition	Comment
09/2012	First Edition
06/2014	Description of devices with capacitive multi-touch screen
11/2014	Update with IPC Wizard 2.1 and corrections

Table of contents

	Preface	3
1	Overview.....	7
1.1	Product description	7
1.2	Scope of delivery	9
1.3	Construction of the devices	10
1.3.1	IFP1500, IFP1900, IFP2200 Multitouch.....	10
1.3.2	IFP1500, IFP1900, IFP2200 Touch.....	12
1.3.3	IFP1500 Touch/Key	13
1.3.4	Interfaces	14
1.3.4.1	Standard versions	14
1.3.4.2	Extended versions	14
1.4	Accessories.....	15
2	Safety information	17
2.1	General safety instructions	17
2.2	Notes about usage.....	19
3	Installing and connecting the device	21
3.1	Preparing for installation	21
3.1.1	Checking the delivery package.....	21
3.1.2	Permitted mounting positions	22
3.1.3	Checking clearances.....	24
3.1.4	Preparing the mounting cutout.....	25
3.1.5	Labeling the function keys	26
3.2	Mounting the device.....	28
3.2.1	Notes on installation.....	28
3.2.2	Mounting clips or mounting brackets, position for IP65.....	29
3.2.3	Fastening the device with mounting clips or mounting brackets	31
3.2.4	Position of the mounting clips for IP66	32
3.3	Connecting the device	33
3.3.1	Overview	33
3.3.2	Notes on connection	35
3.3.3	Connecting the protective earth.....	36
3.3.4	Connecting the power supply	37
3.3.4.1	Connecting the DC power supply	37
3.3.4.2	Connecting an AC power supply	39
3.3.5	Connecting the device to a PC	41
3.3.5.1	Standard version.....	41
3.3.5.2	Extended version	41
3.3.6	Connecting a USB device.....	41
3.3.7	Securing the cables	42
4	Commissioning the device	43
4.1	General information on commissioning	43
4.2	Notes on various device configurations.....	44
4.2.1	SIMATIC IPC Wizard 2.1	44
4.2.1.1	System requirements.....	44
4.2.1.2	Installing IPC Wizard.....	45

5	Operating the device	47
5.1	Operator input options	47
5.2	Operating a device with resistive single touch screen	48
5.3	Operating a device with capacitive multi-touch screen	49
5.4	Operating a Touch/Key device.....	51
5.5	IPC Wizard functions	53
6	Maintaining and servicing your device	55
6.1	Cleaning the device	55
6.2	Spare parts and repairs	56
6.3	Recycling and disposal	56
7	Technical information	57
7.1	Certificates and approvals	57
7.1.1	Programmable logic controllers	60
7.2	Directives and declarations.....	60
7.2.1	ESD guideline	60
7.2.2	Electromagnetic compatibility	62
7.3	Dimension drawings.....	63
7.3.1	Dimension drawing of the IFP1500 Multitouch	63
7.3.2	Dimension drawing of the IFP1500 Monitor and Touch	64
7.3.3	Dimension drawing of the IFP1900 Multitouch	65
7.3.4	Dimension drawing of the IFP1900 Monitor and Touch	66
7.3.5	Dimension drawing of the IFP2200 Multitouch	67
7.3.6	Dimension drawing of the IFP2200 Monitor and Touch	68
7.3.7	Dimension drawing of the IFP1500 Touch/Key	69
7.3.8	Dimension drawing Host Unit USB	70
7.3.9	Dimensions for labeling strips	71
7.4	Rating plate.....	72
7.5	Technical specifications	73
7.5.1	General technical specifications	73
7.5.2	Ambient conditions.....	75
7.5.2.1	Transport and storage conditions	75
7.5.2.2	Operating conditions	76
7.5.2.3	Information on insulation tests, protection class and degree of protection.....	79
7.6	Interface description.....	80
7.6.1	24 V DC Power Supply	80
7.6.2	DVI-D interface.....	81
7.6.3	DisplayPort.....	82
7.6.4	USB interface, Type B	83
7.6.5	USB hub, Type A	83
A	Technical Support	85
A.1	Service and support	85
B	List of abbreviations	87
	Glossary	89
	Index	91

Overview

1.1 Product description

SIMATIC Industrial Flat Panels are LCD monitors suitable for industrial use with a brilliant TFT display which can be connected to all SIMATIC IPCs as well as almost all generally available PCs.



Features of SIMATIC Industrial Flat Panels



- Rugged front
- Brilliant TFT display with a wide reading angle;
Resistive single touch screen in sizes 15", 19" and 22"
Capacitive multi-touch screen available in sizes 15", 19" and 22"
- Available as pure display device (monitor) or touch device
- Can be placed up to 5 m from the IPC
- DVI-D and DisplayPort V1.1 interface
- Multi-monitoring support
- Backlighting can be dimmed via software
- 24 V DC power supply
- Degree of protection IP65 in installed state
- Enclosure type: Front face only Type 4X/Type 12 (indoor use only)
- Up to 16 million colors

Additional features of the Extended versions

- Up to 30 m away from PC possible via DVI
- Power supply (with USB) 24 V DC and 100-240 V AC
- 2 USB ports
- Also available as touch/key version with front USB interface

1.2 Scope of delivery

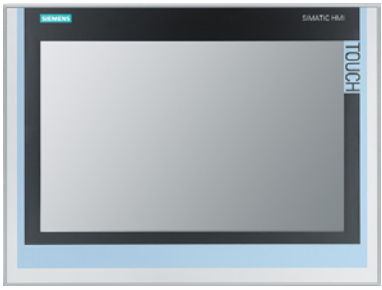
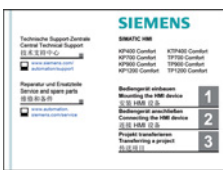
The product package includes the following components:

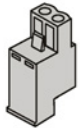
Name	Figure	Number
Industrial Flat Panel		1
Installation instructions (Quick Install Guide)		1
"Mounting clips and power supply plugs" accessory kit		12
		1
"Connecting cables" accessory kit	DVI connecting cable 2 m in length, for commissioning	1
	USB connecting cable, 2 m ¹	1
	Power supply cable 230 V AC ²	1
"Documentation and Drivers" CD		1

¹ Not with standard display device (monitor)

² Only for devices with AC power supply

1.3 Construction of the devices

1.3.1 IFP1500, IFP1900, IFP2200 Multitouch

This section describes the design of the multi-touch devices, using the IFP1900 Multitouch as an example.

Front view and side view

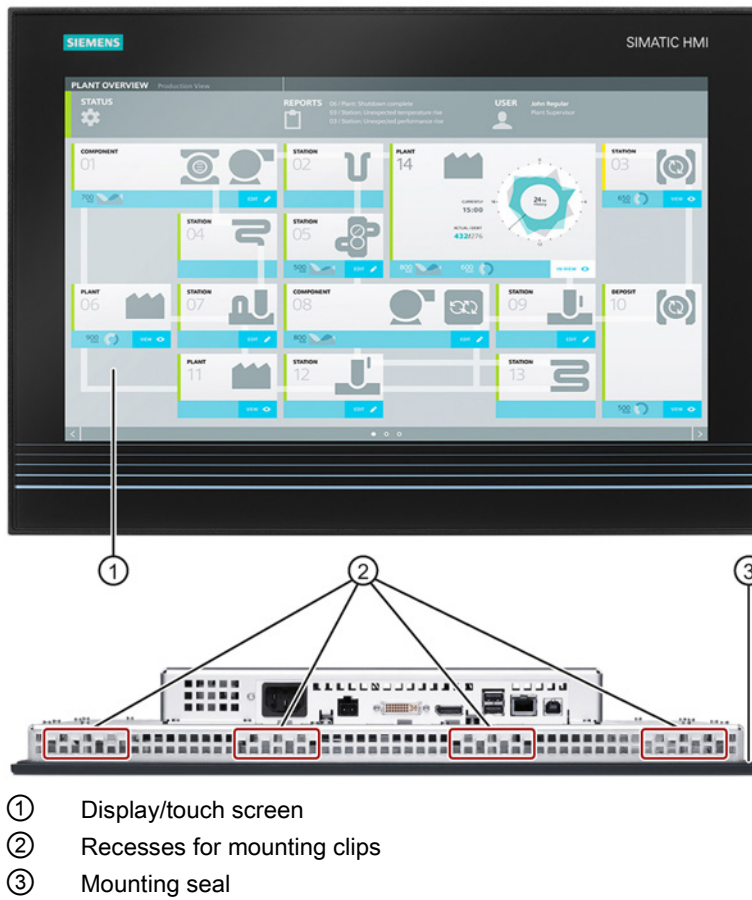

Rear view

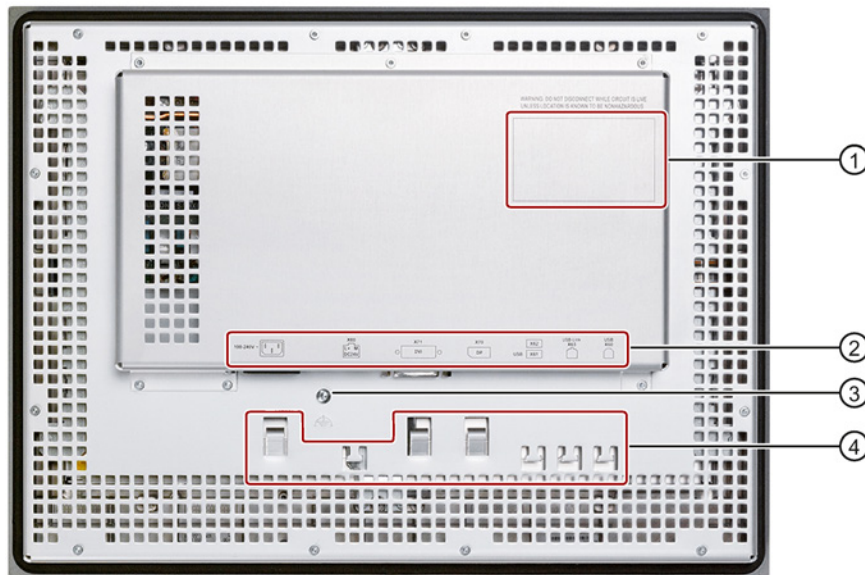

- ① Rating plate
- ② Interface name
- ③ Equipotential bonding
- ④ Retaining elements for strain relief of the connecting cables

1.3.2 IFP1500, IFP1900, IFP2200 Touch

This section describes the design of the monitor and touch devices, using the IFP1500 Touch as an example.

Front view and side view

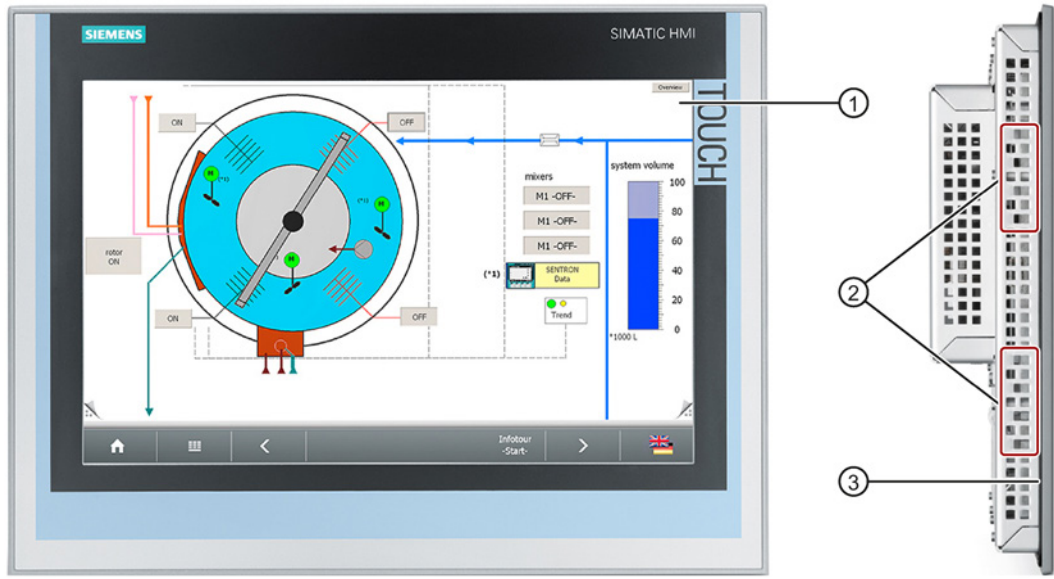

- ① Display/touch screen
- ② Recesses for mounting clips
- ③ Mounting seal

Rear view

See section "IFP1500, IFP1900, IFP2200 Multitouch".

1.3.3 IFP1500 Touch/Key

Front view

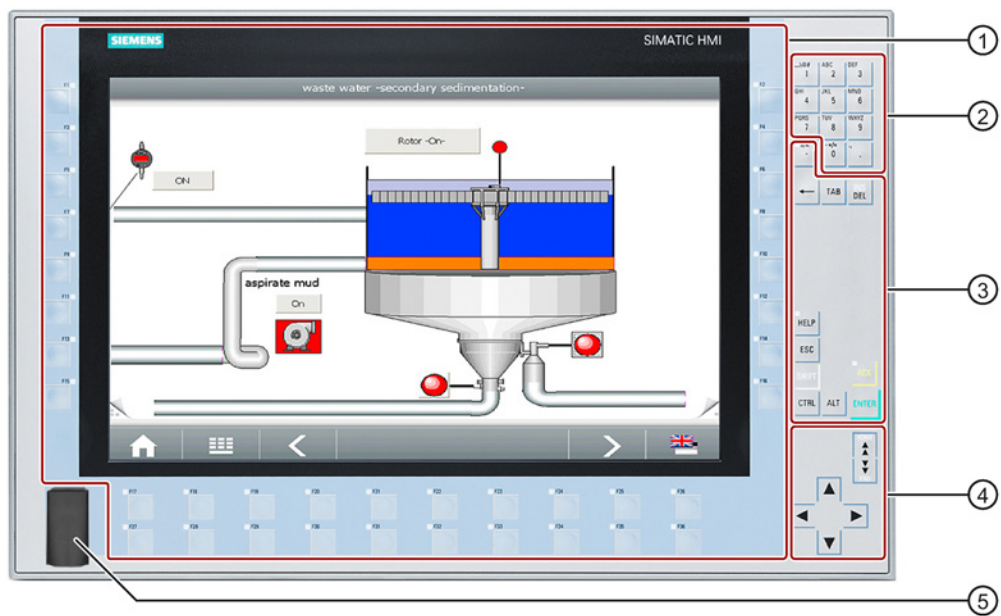

- ① Display and function keys with LED
- ② Alphanumeric keys
- ③ Control keys
- ④ Cursor keys
- ⑤ USB port

1.3.4 Interfaces

1.3.4.1 Standard versions

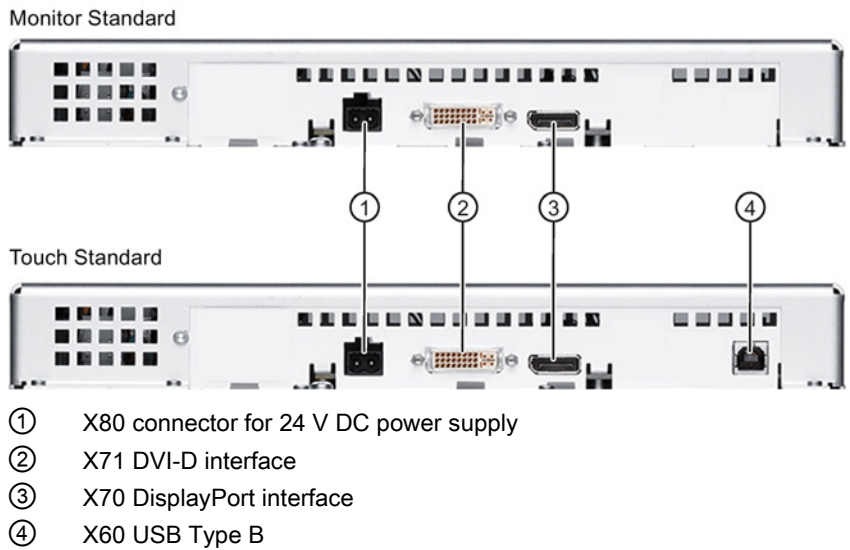

1.3.4.2 Extended versions

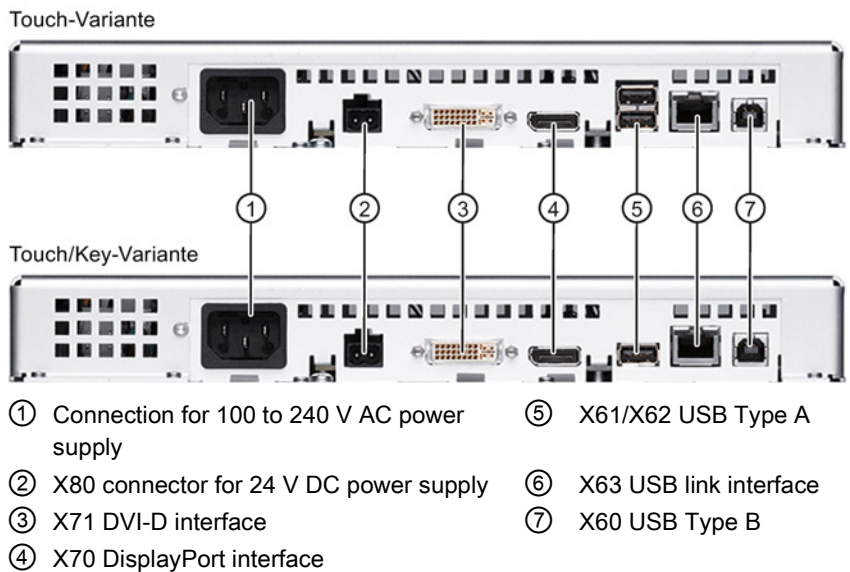

1.4 Accessories

This section contains the number of accessories available at the time of publication of the operating instructions. You will find additional accessories on the Internet at:

- Industry Mall (<https://mall.industry.siemens.com>)
- Expansion components and accessories (http://www.automation.siemens.com/mcms/pc-based-automation/en/industrial-pc/expansion_components_accessories)

All Industrial Flat Panels

Name	Specification	Order number
DVI line	3 m long	6AV7860-0BH30-0AA0
	5 m long	6AV7860-0BH50-0AA0
DisplayPort line	3 m long	6AV7860-0DH30-0AA0
	5 m long	6AV7860-0DH50-0AA0
USB line	3 m long	6AV7860-0CH30-0AA0
	5 m long	6AV7860-0CH50-0AA0
Protective foil for the touch screen	15"	6AV2124-6QJ00-0AX0
	19"	6AV2124-6UJ00-0AX0
	22"	6AV2124-6XJ00-0AX0
Mounting clips service pack	20 pieces	6AV6671-8XK00-0AX3
Mounting brackets service pack	2 x 8 latch fasteners	6AV7672-1JC00-0AA0
Touch pen	only for devices with resistive single touch screen	6AV7672-1JB00-0AA0

Extended version

Name	Specification	Order number
Cable set (DVI/USB cable)	10 m long	6AV7860-1EX21-0AA1
	15 m long	6AV7860-1EX21-5AA1
	20 m long	6AV7860-1EX22-0AA1
	30 m long	6AV7860-1EX23-0AA1

Touch/Key Extended version

Name	Specification	Order number
Film for labeling the function keys (slide-in labels)	Print templates for the slide-in labels are available on the "Documentation and Drivers" CD/DVD.	6AV7672-0DA00-0AA0

Safety information

2.1 General safety instructions

Open equipment and the Machinery Directive

 WARNING
<p>The device constitutes open equipment</p> <p>The device constitutes open equipment. This means that the device may only be installed in enclosures or cabinets which provide front access for operating the device.</p> <p>Access to the enclosure or cabinet in which the device is installed should only be possible by means of a key or tool and for trained and authorized personnel.</p> <p>Electrocution risk when control cabinet is open</p> <p>When you open the control cabinet, there may be a dangerous voltage at certain areas or components.</p> <p>Touching these areas or components can cause electrocution.</p> <p>Always disconnect the cabinet from the mains before opening it.</p> <p>The device may only be used in machines which comply with the Machinery Directive</p> <p>The Machinery Directive specifies precautions to be taken when commissioning and operating machinery within the European Economic Area.</p> <p>Failure to follow these precautions is a breach of the Machinery Directive. Such failure may also cause personal injury and damage depending on the machine operated.</p> <p>The machine in which the HMI device is to be operated must conform to Directive 2006/42/EC.</p>

Hazardous areas

When operating the HMI device in hazardous areas the following warning applies.

 WARNING
<p>Explosion Hazard</p> <p>Do not disconnect while circuit is live unless area is known to be non-hazardous. Substitution of components may impair suitability for Class I, Division 2 or Zone 2.</p> <p>Risque d'Explosion</p> <p>Ne pas déconnecter pendant que le circuit est sous tension, sauf si la zone est non-dangereuse. Le remplacement de composants peut compromettre leur capacité à satisfaire à la Classe I, Division 2 ou Zone 2.</p>

High frequency radiation

NOTICE

Unwanted operating states

High-frequency radiation, for example from cellular phones, interferes with device functions and can cause device malfunction.

This causes injury and damages the system.

Avoid high-frequency radiation:

- Remove the sources of radiation from the vicinity of the device.
- Switch off radiating devices.
- Reduce the radio output of radiating devices.
- Observe the information on electromagnetic compatibility (Page 76).

Industrial Security

Siemens offers products and solutions with Industrial Security functions that support the safe operation of equipment, solutions, machines, devices and/or networks. They are important components in a comprehensive Industrial Security concept. As a result the products and solutions from Siemens are constantly evolving. Siemens recommends obtaining regular information regarding product updates.

For safe operation of Siemens products and solutions appropriate protective measures (e.g., cell protection concept) must be taken and each component must be integrated in a comprehensive Industrial Security concept, which corresponds with the current state of technology. The products of other manufacturers need to be taken into consideration if they are also used. You can find addition information on Industrial Security under (<http://www.siemens.com/industrialsecurity>).

Sign up for our product-specific newsletter to receive the latest information on product updates. For more information, see under (http://www.siemens.de/automation/csi_en_WW).

Disclaimer for third-party software updates

This product includes third-party software. Siemens AG only provides a warranty for updates/patches of the third-party software, if these have been distributed as part of a Siemens software update service contract or officially released by Siemens AG. Otherwise, updates/patches are undertaken at your own risk. You can find more information about our Software Update Service offer on the Internet at Software Update Service (<http://www.automation.siemens.com/mcms/automation-software/en/software-update-service/Pages/Default.aspx>).

Notes on protecting administrator accounts

A user with administrator privileges has extensive access and manipulation options in the system.

Therefore, ensure there are adequate safeguards for protecting the administrator accounts to prevent unauthorized changes. To do this, use secure passwords and a standard user account for normal operation. Other measures, such as the use of security policies, should be applied as needed.

2.2 Notes about usage

NOTICE
Device is approved for indoor use only The device may be damaged if operated outdoors. <ul style="list-style-type: none">• "Indoor use only"• Operate the device indoors only.

Industrial applications

The device is designed for industrial use. It conforms to the following standards:

- Requirements of the emission standard for industrial environments, EN 61000-6-4: 2007
- Requirements for interference immunity EN 61000-6-2: 2005
- Immunity to interference acc. to EN 55024
- Radio interference suppression acc. to EN 55022, Class B

Use in residential areas

Note

Device is not intended for use in residential areas

The device is not intended for use in residential areas. Operating the device in residential areas can affect radio or TV reception.

If you operate the device in a residential area, you must ensure conformance to Class B limits according to EN 55011 regarding the emission of radio interference.

Suitable measures for achieving the degree of noise suppression for Limit Class B include, for example:

- Installation of the device in grounded control cabinets
- Use of filters in electrical supply lines

Individual acceptance is required.

Risk analysis and measures

 WARNING
Hazards emanating from unprotected machines or plants The results of a risk analysis can reveal any hazards emanating from unprotected machinery. Such hazards may pose a risk of personal injury. You can prevent personal injury caused by hazards as specified in the risk analysis by taking the following measures: <ul style="list-style-type: none">• Installing additional protective devices on machinery and plants. In particular, it must also be ensured that the programming, configuration and wiring of all I/Os used takes place in accordance with the safety performance (SIL, PL or Cat.) identified by the requisite risk analysis.• Use of the device in accordance with its intended purpose, which can be verified by means of a system function test. This test can detect programming, configuration and wiring errors.• Documentation of the test results, which must be entered in the relevant safety reports if required.

Environment

NOTICE

Ambient conditions and chemical resistance

Ambient conditions not suited for the device can adversely affect operation. Chemical agents, such as detergents or operating material, can change the color, shape and structure of the device surface. The device may be damaged. This may lead to malfunctions.

For this reason, the following precautionary measures should be taken:

- Only operate the device in closed rooms. Failure to comply with these instructions will render the warranty null and void.
- Only operate the device in the ambient conditions specified in the technical specifications.
- Protect the device against dust, moisture and heat.
- The device may not be used in harsh operating environments, such as areas subject to acidic vapors or gases, without additional protective measures (e.g. a clean air supply).
- Only use suitable detergents. Only use suitable detergents. Read the information about Chemical resistance of the HMI devices and industrial PCs (<http://support.automation.siemens.com/WW/view/en/39718396>) on the Internet.

TFT displays

NOTICE

Burn-in effect and backlight

A permanent picture with bright images can result in a burn-in effect. The longer the same content is displayed on the screen, the longer it will take for the burn-in effect to disappear. Screen savers that use active black when the backlight is on reduce the burn-in effect. The brightness of the backlight decreases incrementally during operational life.

- Activate the screen saver, for example, "starfield simulation".

You can extend the service life of the display and the backlight with the following measures:

- Reduce the backlight.
- Pay attention to the length of time the backlight is activated.

Additional information is available in the section "General Technical Specifications".

Defective pixels in the display

The manufacturing process of modern displays does not currently guarantee that all pixels of the display are perfect. It is therefore inevitable that the display will contain a small number of defective pixels. This does not limit the function in any way provided the defective pixels are not all in one location.

Additional information is available in the section "General Technical Specifications".

Installing and connecting the device

3.1 Preparing for installation

3.1.1 Checking the delivery package

Procedure

1. When accepting a delivery, please check the packaging for visible transport damage.
2. If any transport damage is present at the time of delivery, lodge a complaint at the shipping company in charge. Have the shipper confirm the transport damage immediately.
3. Unpack the device at its installation location.
4. Keep the original packaging in case you have to transport the unit again.

Note

Damage to the device during transport and storage

If a device is transported or stored without packaging, shocks, vibrations, pressure and moisture may impact the unprotected unit. Damaged packaging indicates that ambient conditions have already had a massive impact on the device and it may be damaged.

This may cause the device, machine or plant to malfunction.

- Keep the original packaging.
 - Pack the device in the original packaging for transportation and storage.
-

5. Check the contents of the packaging and any accessories you may have ordered for completeness and damage.
6. Please inform the delivery service immediately if the package contents are incomplete or damaged or do not correspond with your order. Fax the enclosed form "SIMATIC IPC/PG Quality Control Report".

 WARNING
--

Electric shock and fire hazard due to damaged device

<p>A damaged device can be under hazardous voltage and trigger a fire in the machine or plant. A damaged device has unpredictable properties and states.</p>
--

<p>Death or serious injury could occur.</p>

<p>Make sure that the damaged device is not inadvertently installed and put into operation. Label the damaged device and keep it locked away. Send off the device for immediate repair.</p>

3.1 Preparing for installation

NOTICE
Damage from condensation If the device is subjected to low temperatures or extreme fluctuations in temperature during transportation, as is the case in cold weather, for example, moisture can build up on or inside the device (condensation). Moisture causes a short circuit in electrical circuits and damages the device. In order to prevent damage to the device, proceed as follows: <ul style="list-style-type: none">• Store the device in a dry place.• Bring the device to room temperature before starting it up.• Do not expose the device to direct heat radiation from a heating device.• If condensation develops, wait approximately 12 hours or until the device is completely dry before switching it on.

- 7. Please keep the enclosed documentation in a safe place. It belongs to the device. You need the documentation when you commission the device for the first time.
- 8. Write down the identification data of the device.

3.1.2 Permitted mounting positions

The device is suitable for installation in:

- Mounting cabinets
- Control cabinets
- Switchboards
- Consoles

In the following, all of these mounting options are referred to by the general term "cabinet".

The device is self-ventilated and approved for inclined mounting at angles up to +/-35° in stationary cabinets.

NOTICE
Damage due to overheating Inclined installation reduces the convection by the device and therefore the maximum permitted ambient temperature for operation. If there is sufficient forced ventilation, the device can also be operated in the inclined mounting position up to the maximum permitted ambient temperature for vertical installation. The device may otherwise be damaged and its certifications and warranty will be rendered null and void.

For information on permitted ambient temperatures, refer to the section Technical specifications (Page 73).

Mounting position

Select one of the approved mounting positions for your device. The approved mounting positions are described in the following sections.

Mounting in horizontal format

All devices are suitable for horizontal mounting positions.

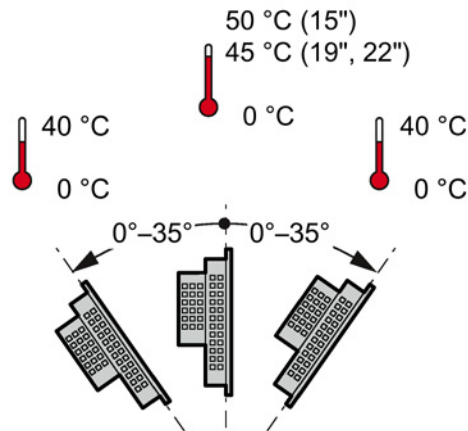

A maximum ambient temperature of +50 °C is permitted for vertical mounting of the IFP1500 (0° tilt angle); a maximum of +40 °C is permitted for inclined mounting.

The ambient temperature for the IFP1900 and IFP2200 when installed vertically should not exceed +45 °C.

Mounting in vertical format

All monitor and touch versions also support vertical mounting.

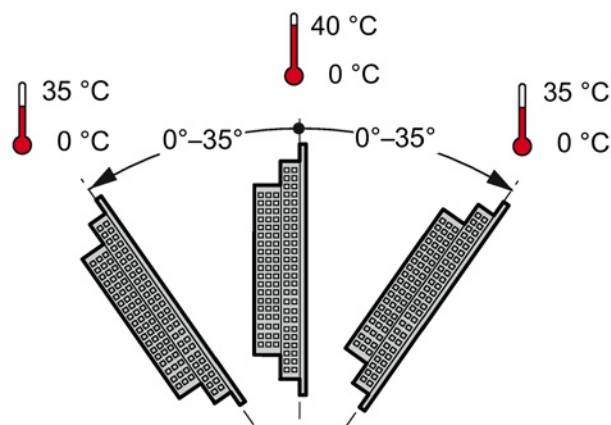

A maximum ambient temperature of +40 °C is permissible for vertical mounting (0° tilt angle); a maximum of +35 °C is permitted for inclined mounting.

3.1.3 Checking clearances

The following clearances are required around the device to ensure adequate self-ventilation:

- At least 15 mm to the right and left of the mounting cutout (in x direction) to allow for insertion of the mounting clips during installation
- At least 50 mm above and below the mounting cutout (in y direction) for ventilation
- At least 10 mm behind the rear panel of the device (in z direction)

The figure below shows the clearances required with horizontal and vertical installation of the device:

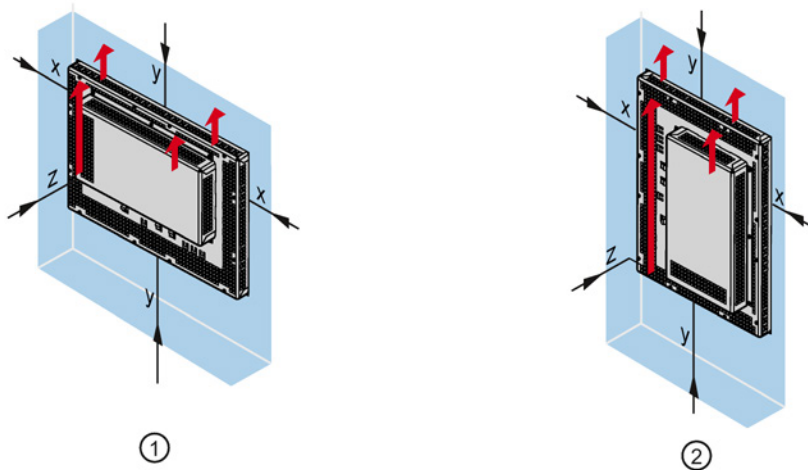

- ① Clearance for horizontal installation (all devices)
- ② Clearance for vertical installation (monitor and touch versions only)
- x At least 15 mm distance
- y At least 50 mm distance
- z At least 10 mm distance

Note

Ensure that the maximum ambient temperature is not exceeded when mounting the device in a cabinet and especially in a closed enclosure.

3.1.4 Preparing the mounting cutout

Note

Stability of the mounting cutout

The material in the area of the mounting cutout must be sturdy enough to ensure permanent safe mounting of the device.

To achieve the degrees of protection described below, it must be ensured that deformation of the material cannot occur due to the force of the mounting clips or operation of the device.

Degrees of protection

The various degrees of protection of the device can only be guaranteed if the following requirements are met:

- To achieve the degree of protection specified in the technical specifications: Material thickness at the mounting cut-out: 2 mm to 6 mm
- Permitted deviation from plane at the mounting cutout: ≤ 0.5 mm
This condition must also be met for the installed device.
- Permitted surface roughness in the area of the seal: ≤ 120 μm (R_z 120)

Dimensions of the mounting cutout

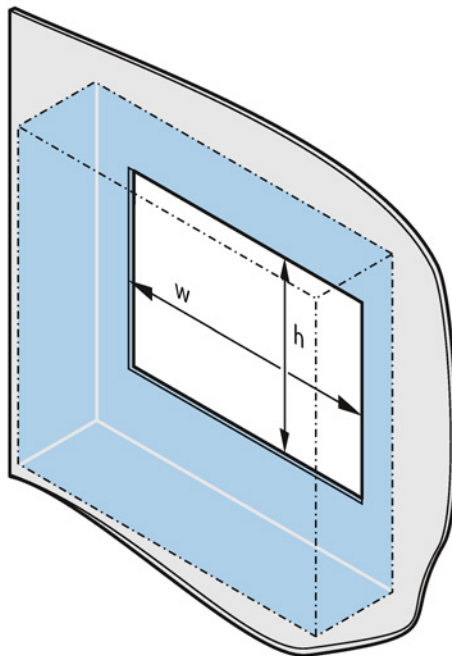

	$w \begin{smallmatrix} +1 \\ 0 \end{smallmatrix}$	$h \begin{smallmatrix} +1 \\ 0 \end{smallmatrix}$
IFP1500 Monitor/Touch	396	291
IFP1500 Multitouch	399	280
IFP1900 Monitor/Touch/Multitouch	465	319
IFP2200 Monitor/Touch/Multitouch	542	362
IFP1500 Touch/Key	450	291

Figure 3-1 Mounting cutout

Width and height should be reversed accordingly when mounting in vertical format.

3.1.5 Labeling the function keys

Use labeling strips for project-related labeling of the function keys of your device.

Labeling strip templates are available in a Word document on the Internet at:

Labeling strips for 15" widescreen

(<http://support.automation.siemens.com/DE/view/en/59000814>)

If you would like to make your own labeling strips, you can find the dimensions under "Dimensions for labeling strips (Page 71)".

Note

Do not write on the keyboard to label the function keys.

Any printable and writable film can be used as labeling strip. The permitted thickness of the labeling strip is 0.15 mm. Do not use paper labeling strips.

Procedure

Proceed as follows:

1. Edit the template on a PC and then print it.
2. Apply a fixation spray film to the labeling strips.
The printout can be made water and smudge-proof with a fixation spray. The color printer ink will not bleed onto the keyboard film as well.
3. Cut out the labeling strip.
4. Cut the corners at a 45° angle so that it is easier to slide the strip into the slot.
5. When the ink has dried, slide the labeling strips into the guide leaving a 3 cm clearance at the end.

The figure below shows the positions of the guides for the labeling strips of the 15" Touch/Key version.

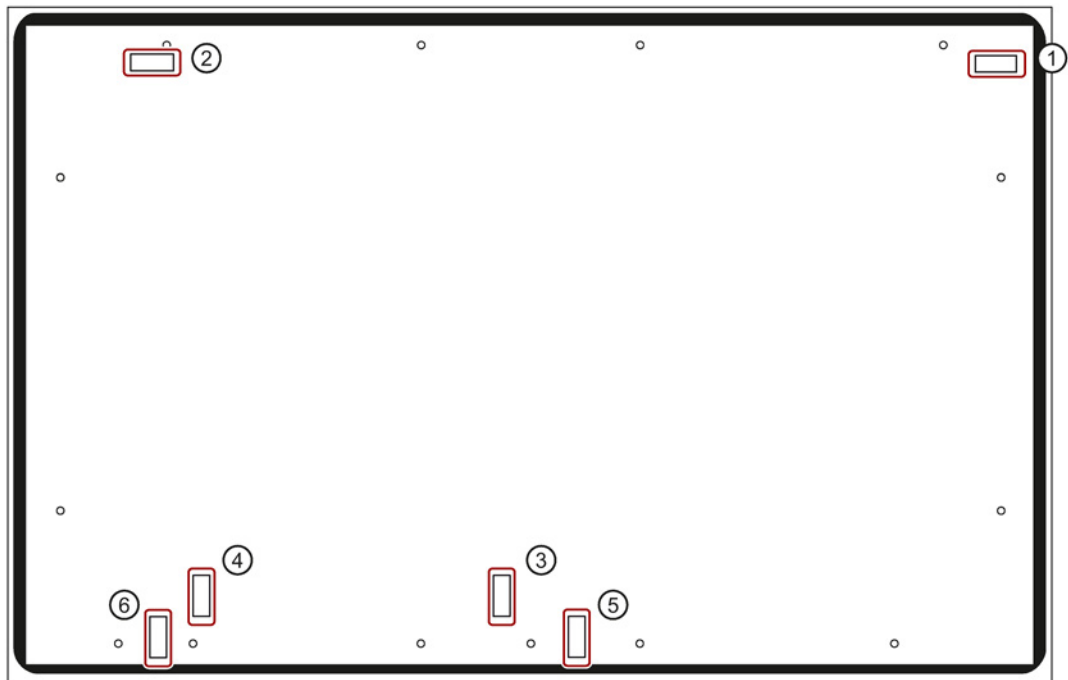

- ① Guide for labeling strips F1, F3 ... F15
- ② Guide for labeling strips F2, F4 ... F16
- ③ Guide for labeling strips F17 ... F22
- ④ Guide for labeling strips F23 ... F26
- ⑤ Guide for labeling strips F27 ... F31
- ⑥ Guide for labeling strips F32 ... F36

Result

The labeling strips protrude approximately 3 cm out of the slot. The template dimensions for the labeling strips are designed so that the labeling is correctly placed for the function keys. It is not necessary to secure the labeling strip.

When installing the device, make sure that the labeling strips do not get jammed between the mounting cutout and the device.

3.2 Mounting the device

3.2.1 Notes on installation

Before installing the device, please ensure that the installation location complies with the following:

 **WARNING**

Risk of fire

The device is classified for use as "Open Type" according to UL508 in the Industrial Control Equipment sector. In the event of overheating, the device may discharge burning materials that can cause a fire.

Keep in mind:

- Requirement for approval and operation of the device according to UL508 is its installation in a UL508-compliant enclosure.
 - Install the device in an enclosure that meets the requirements of paragraphs 4.6 and 4.7.3 of the standards IEC/UL/EN/DIN-EN 60950-1.
-
- Ensure that the protective contact socket of the building installation is easily accessible and that there is a mains disconnect switch in switchgear cabinet installations.
 - Position the device so that it is not exposed to direct sunlight.
 - Position the device so that it is easily accessible for the operator.
 - Choose a suitable installation height.
 - Ensure that the air vents of the device are not covered as a result of installation. Note the permitted mounting positions.

3.2.2 Mounting clips or mounting brackets, position for IP65

Types of mounting clips and mounting brackets

You can mount the device as follows:

- Device with 15", 19" or 22" display:

With 12 steel mounting clips (included in the scope of supply and available as accessories, see section "Accessories")



- Device with 15", 19" or 22" display:

With 6 mounting brackets (available as accessories, see section "Accessories")

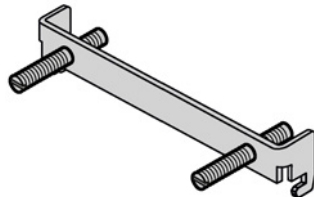

Positions of the mounting clips or mounting brackets for IP65

To achieve the IP65 degree of protection for the device, the mounting clips or brackets must be affixed at the positions shown below.

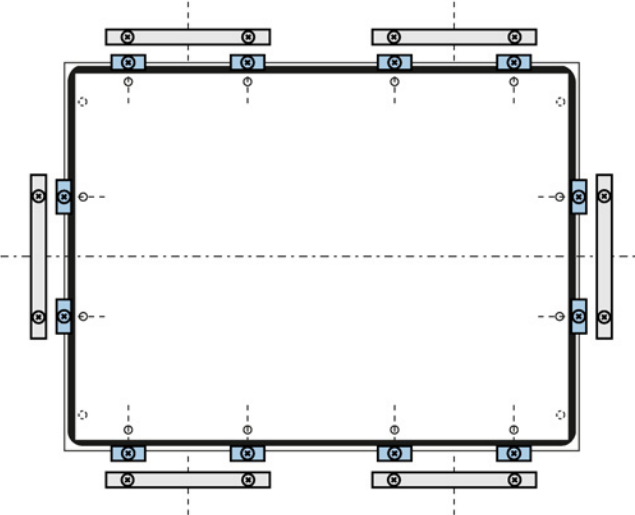
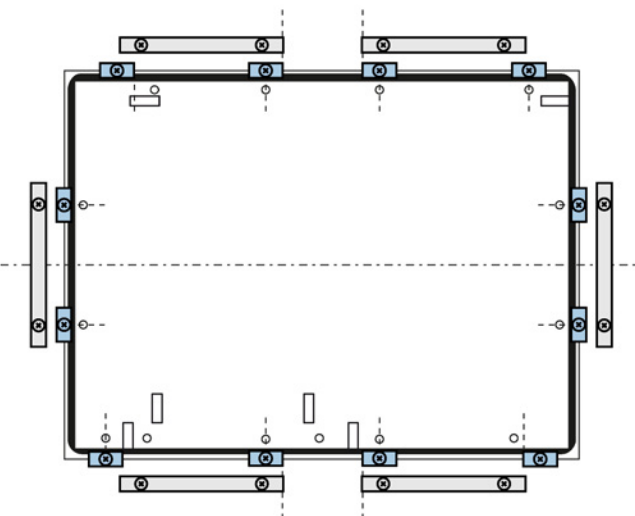
Device	Position
Touch screen device with: <ul style="list-style-type: none"> • 15" display • 19" display • 22" display 	
Touch/key device with: <ul style="list-style-type: none"> • 15" display 	

3.2.3 Fastening the device with mounting clips or mounting brackets

Requirement

- All packaging components and protective films have been removed from the device.
- The mounting clips included in the accessory kit are to hand.

Procedure

Note

If the mounting seal is damaged, the degree of protection is not guaranteed.

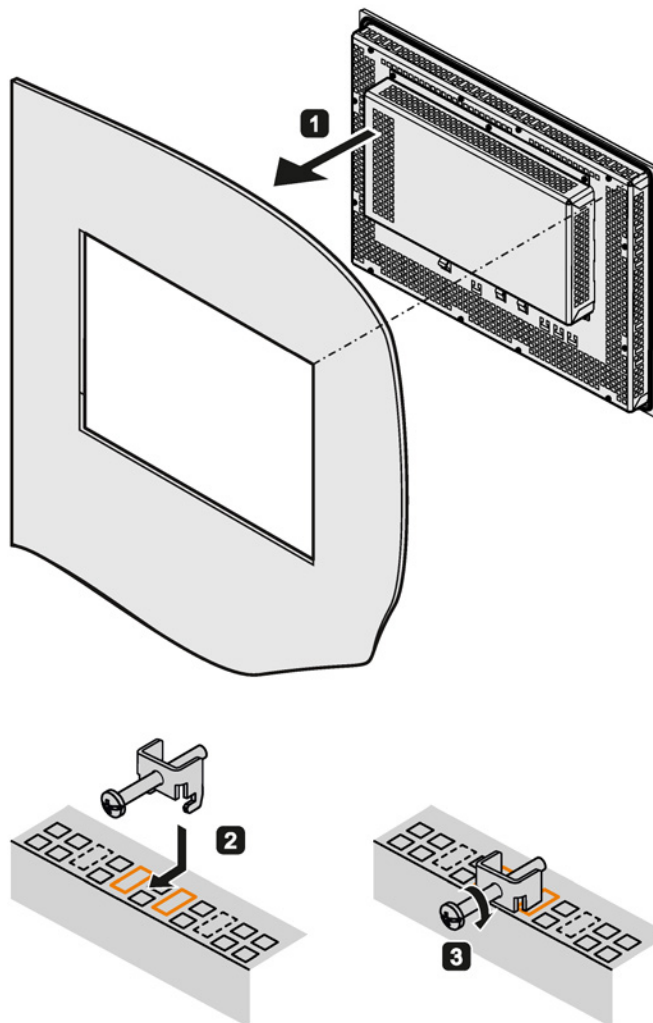

Proceed as follows:

1. Working from the front, insert the device into the mounting cut-out. Secure the device to prevent it from falling out.
2. Insert a mounting clip into the cutout provided on the device. Make sure it is in the correct position; see the section "Mounting clips or mounting brackets, position for IP65 (Page 29)".
3. Tighten the threaded pin to secure the mounting clip. The maximum torque when tightening the threaded pins of the mounting clips is 0.5 Nm.
4. Repeat steps 2 and 3 for all mounting clips.
5. Check the fit of the mounting seal.

Mounting with optional mounting brackets

Mounting brackets can be used instead of mounting clips in steps 1 to 5:

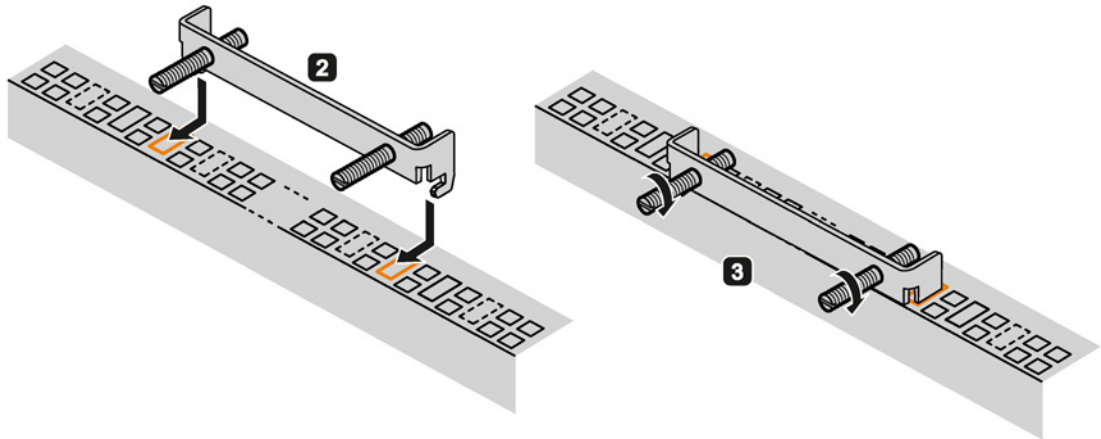

3.2.4 Position of the mounting clips for IP66

Positions of the mounting clips

To achieve IP66 degree of protection instead of IP65 for a device with capacitive multi-touch screen, fasten 4 additional mounting clips (available as accessories) at the positions marked by the red boxes. The 15" display meets IP66 even without additional mounting clips.

Device	Position
Touch screen device with: <ul style="list-style-type: none"> • 19" display • 22" display 	

3.3 Connecting the device

3.3.1 Overview

Connection diagram for standard monitor version

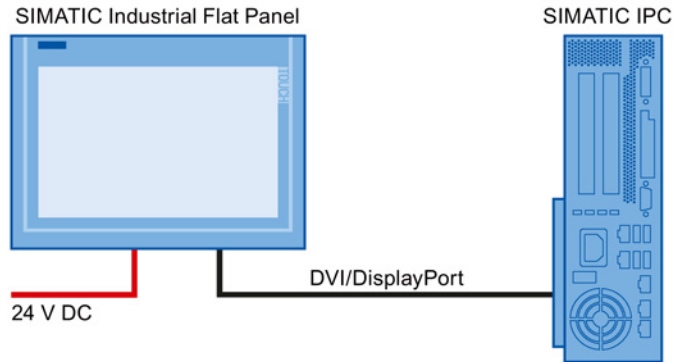

Connection diagram for standard touch version

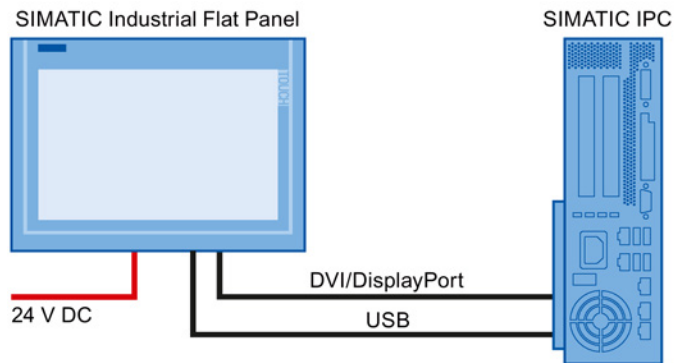

Connection diagram for extended versions

Distance up to 5 meters

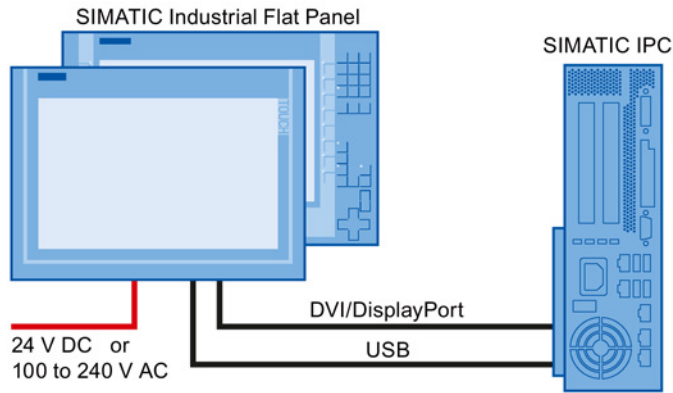

Distance of 5m to 30m

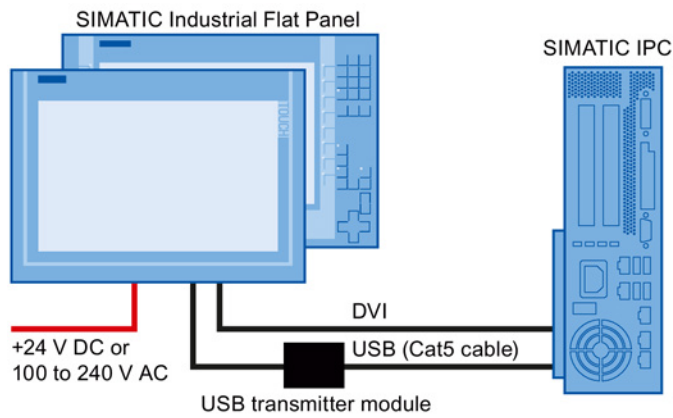

3.3.2 Notes on connection

Requirement

- The device has been installed according to the information provided in these operating instructions.
- Ensure only shielded data cables are used for operation, as described in the section Accessories (Page 15).

Connection sequence

Connect the device in the following sequence:

1. PE conductor
2. Power supply

Perform a power-up test to ensure the power supply is connected with the correct polarity.

3. PC
4. I/Os if needed

Note

Damage to the device

Failure to adhere to the connection sequence can damage the device.

Make sure you connect the device according to sequence listed above.

You disconnect the device in the reverse order.

Connecting the cables

When connecting the cables, make sure that you do not bend the contact pins.

3.3.3 Connecting the protective earth

The relevant symbol on the device identifies the terminal for the earth connection.



Requirement

- T20 screwdriver
- Cable lug for M4
- PE conductor with a minimum cross-section of 2.5 mm²

Procedure

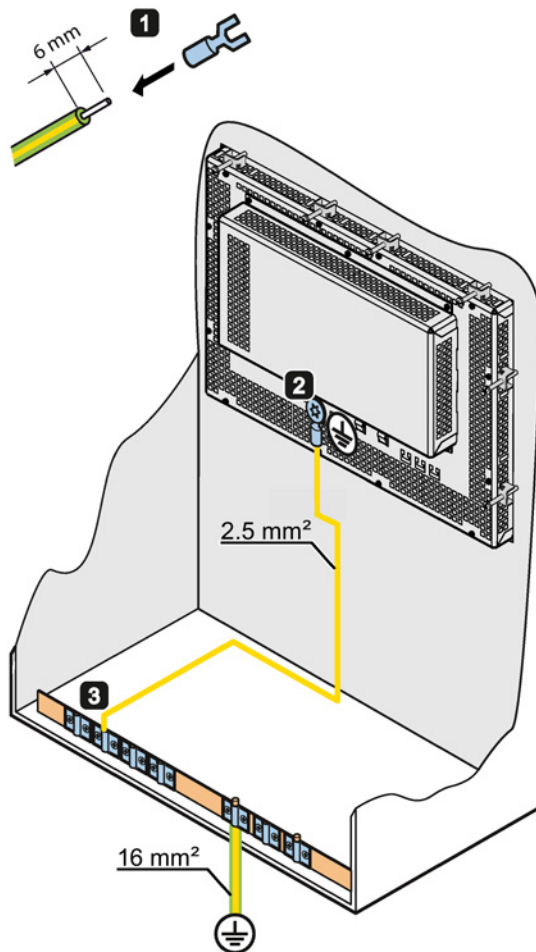

1. Clamp the cable lug onto the earth connection.
 - PE conductor: yellow-green, as depicted.
 - Equipotential bonding: black
2. Using the M4 thread, firmly attach the cable lug to the earth connection on the device.
3. Connect the PE conductor or equipotential bonding with the earth connection of the cabinet or plant in which the device is installed.

3.3.4 Connecting the power supply

Depending on the device version, you can operate the device with the following voltage:

- Standard monitor and standard touch versions: 24 V DC
- Extended versions: 24 V DC or 100 to 240 V AC

Note

To turn off the device completely, disconnect it from the power supply. The device does not have an on/off switch.

3.3.4.1 Connecting the DC power supply

Note before connecting

NOTICE
Damage to device due to inadequate cable cross-section
Using power supply cables with cross-sections that are too small can damage the device in the event of a short circuit. Only connect cables, therefore, with a minimum cross-section of 1.3 mm ² (16 AWG) and a maximum cross-section of 3.3 mm ² (12 AWG).

Note

The device may only be connected to a 24 V DC power supply that meets the requirements of a safe extra-low voltage (SELV) according to IEC/EN/DIN EN/UL 60950-1.

The power supply must meet the requirements of NEC Class 2 or LPS according to IEC/EN/DIN EN/UL 60950-1.

Since the ground/negative pole of the 24 V power supply and PE are connected to the housing, the **SELV** power supply automatically becomes a **PELV** power supply. Bear this in mind when connecting other devices.

Procedure

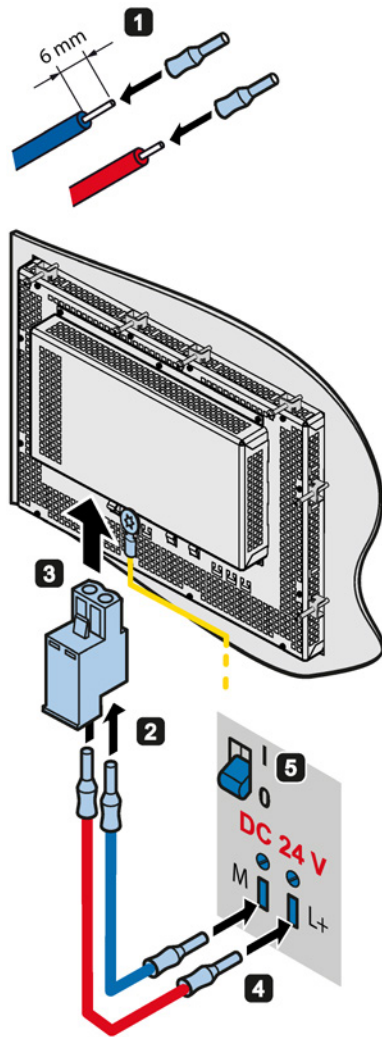

1. Ensure that the cable ends of the power supply lines are fitted with end sleeves.
2. Fasten the end of a connecting cable L+ and a connecting cable M with the supplied power supply terminal.
3. Connect the power supply terminal to the relevant terminal on the device.
4. Connect the remaining L+ and M ends with the respective terminals on the 24 V DC power supply.
5. Switch on the 24 V DC power supply.

3.3.4.2 Connecting an AC power supply

Note before connecting

NOTICE**Damage to the device in ungrounded supply systems**

The device features a safety-certified power cable. Connect the device only to a grounding socket. Operate the device only on grounded-neutral systems and not on impedance-grounded systems such as IT networks.

NOTICE**Damage to the device due to connection to the wrong supply voltage**

If the local supply voltage is incompatible with the permissible rated voltage for the device, damage to the equipment may result.

Always make sure that the local supply voltage complies with the permissible rated voltage for the device.

Regional information

Outside the United States and Canada, in regions with 230 V supply voltage:

If you do not use the safety-certified power cable, use a flexible, double-insulated power supply cable (no single cables) with the following characteristics:

- At least 18 AWG (0.75 mm²) conductor cross-section
- Grounded safety plug 15 A, 250 V

Note

Ensure that the cable set conforms to the respective national safety regulations and is appropriately labeled.

For USA and Canada:

A CSA or UL-listed power supply cable must be used in the United States and Canada.

120 V power supply

Use a flexible cable with the following characteristics:

- UL approval
- CE marking
- Type SJT with three conductors
- At least 18 AWG (0.75 mm²) conductor cross-section
- Maximum 4.5 m length
- Parallel grounded safety plug 15 A, min. 125 V

230 V power supply

Use a flexible cable with the following characteristics:

- UL approval
- CE marking
- Type SJT with three conductors
- At least 18 AWG (0.75 mm²) conductor cross-section
- Maximum 4.5 m length
- Tandem grounded safety plug 15 A, min. 250 V

Procedure

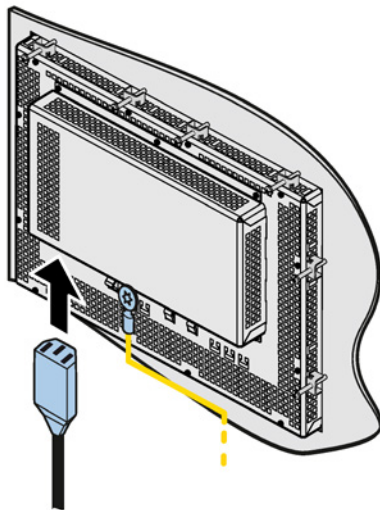

Plug the connector of the supplied power supply cable in the AC power supply connector of the device.

3.3.5 Connecting the device to a PC

3.3.5.1 Standard version

Procedure

1. Connect the Flat Panel and the PC using a DVI or DisplayPort line.
2. If using a Touch version, also connect the device and the PC with a USB line.



3.3.5.2 Extended version

Procedure

1. Connect the Flat Panel and the PC using a DVI or DisplayPort line by means of the respective interface.
2. If the distance between the Flat Panel and the PC is less than 5 m, connect the Flat Panel and PC using the USB Type B interface.
3. If the distance between the Flat Panel and the PC is less than 5 m, connect the Flat Panel and PC with USB transmitter module by means of the USB-Link interface.



Note

Data transfer per USB transmitter module via USB1.1. The data transmission rate corresponds to Full Speed according to USB1.1.

3.3.6 Connecting a USB device

Below are examples of devices you can connect to the USB interfaces of the device:

- External mouse
- External keyboard
- USB memory stick

Note when connecting

Note

Use of USB devices

- The cable length of USB peripherals cannot exceed 3 m.
 - Wait at least ten seconds between removal and reconnection of USB devices.
 - When using standard USB peripherals, bear in mind that their EMC immunity level is frequently designed for office applications only. These devices may be used for commissioning and servicing. However, only industry-standard devices are allowed for industrial operation.
 - Peripherals are developed and marketed by individual vendors. The respective supplier offers support for the I/O devices. Moreover, the terms of liability of the individual vendors or suppliers apply here.
-

Note

Functional problem with USB port

If you connect an external device with a 230 V power supply to the USB port without using a non-insulated installation, you may experience functional problems.

Use a non-insulated system design.

Excessive rated load on port

A USB device with too high a power load may possibly cause functional problems.

Observe the values for the maximum load of the USB interface. You will find the values in the section "Technical specifications" (Page 73)".

Front USB of the Touch/Key version

Note

Ensuring degree of protection IP65

When you loosen the sealing cover above the USB port to connect a USB component, the degree of protection IP65 is no longer guaranteed for the device.

3.3.7 Securing the cables

Use cable ties to secure the connected cables to the selected fixing elements for strain relief.

Make sure that the cables are not crushed by the cable tie.

The figure below shows the fixing elements of the IFP1500 Touch.



Commissioning the device

4.1 General information on commissioning

If you want to operate the device exclusively as monitor, you do not need to commission the device. To use the IPC Wizard functions (see section "Operating the device"), perform the following commissioning steps.

Requirements

- The Industrial Flat Panel is connected to the power supply.
- The Industrial Flat Panel is connected to a SIMATIC IPC or PC with a DVI or DisplayPort cable.
- The PC is equipped with a CD/DVD drive.
- The USB keyboard and USB mouse are connected to the PC.
- One of the supported operating systems is installed on the PC, see the section "SIMATIC IPC Wizard / system requirements".

Procedure

1. Switch on the power supply of the Industrial Flat Panel.
2. Turn on the PC.
3. Follow the instructions in the section "Installing the SIMATIC IPC Wizard / IPC Wizard".

See also

Preface (Page 3)

4.2 Notes on various device configurations

4.2.1 SIMATIC IPC Wizard 2.1

SIMATIC IPC Wizard for SIMATIC Industrial PCs installs device-specific software and drivers for operating your PC. These software components enable you to set the screen of your SIMATIC device, for example, the brightness.

The SIMATIC IPC Wizard recognizes the existing hardware components and automatically installs the associated software.

- SIMATIC Industrial PCs **with** preinstalled software contain the SIMATIC IPC Wizard that runs automatically during initial commissioning.
- On SIMATIC Industrial PCs **without** preinstalled software, you can install the SIMATIC IPC Wizard from the CD/DVD "Documentation and Drivers" on which the documentation of the SIMATIC IPC Wizard is located.

4.2.1.1 System requirements

Hardware requirements

For the SIMATIC IPC Wizard you require the following hardware:

- PC with connected SIMATIC display: e.g. SIMATIC Panel PC or PC with connected SIMATIC Industrial Flat Panel
- 650 MB of free hard disk space on the PC, C:\ partition
- The SIMATIC IPC display is fully connected:
 - DVI / DP connection for video signals
 - USB connection for touch signals

Note

Connected devices

The SIMATIC IPC Wizard does not support the combination of devices with resistive single-touch screen and capacitive multi-touch screen.

Note for SIMATIC Industrial Flat Panels:

- If you use a SIMATIC Industrial Flat Panel with the PC, connect the Industrial Flat Panel to the PC before initial commissioning.
 - During initial commissioning, multiple SIMATIC Industrial Flat Panels may be connected to the PC.
-

Supported operating systems

The SIMATIC IPC Wizard on PCs runs with the following operating systems:

- Microsoft Windows 32-bit operating system
 - Windows 7 Ultimate with SP1
 - Windows Embedded Standard 7E¹ or 7P with SP1
- Microsoft Windows 64-bit operating system
 - Windows 7 Ultimate with SP1
 - Windows Server 2008 R2
 - Windows Embedded Standard 7E¹ or 7P with SP1

¹ For devices with capacitive multi-touch screen, WES7E is only supported in single-touch mode (see manual "SIMATIC IPC Wizard 2.1", section "Toggling Switch Touch Mode").

Software requirements

- One of the operating systems named in "Supported operating systems" section is installed.
- The driver of the device manufacturer for the graphics adapter is installed.
- The installed graphics driver supports reading of EDID data from the screen.

Note

The Microsoft VESA driver does not support all functions provided by the SIMATIC IPC Wizard.

Setup cancels the installation.

4.2.1.2 Installing IPC Wizard

Requirement

- The system requirements are met.
- Do not apply with factory state: If following previous driver versions exist, uninstall them via "Start > Control Panel > Programs and Features":
 - IPC Wizard V1.0
 - IPC Wizard V2.0
 - IPC Switch Touch Mode V2.0.5

Procedure

1. Turn on the PC.
 - With the factory state of some IPCs, the SIMATIC IPC Wizard is pre-installed. The installation starts the first time the PC is switched on.
 - If your SIMATIC IPC was delivered without pre-installed software, start the installation of the SIMATIC IPC Wizard from the "Documentation and Drivers" CD/DVD. Select the appropriate IPC Wizard for your device.

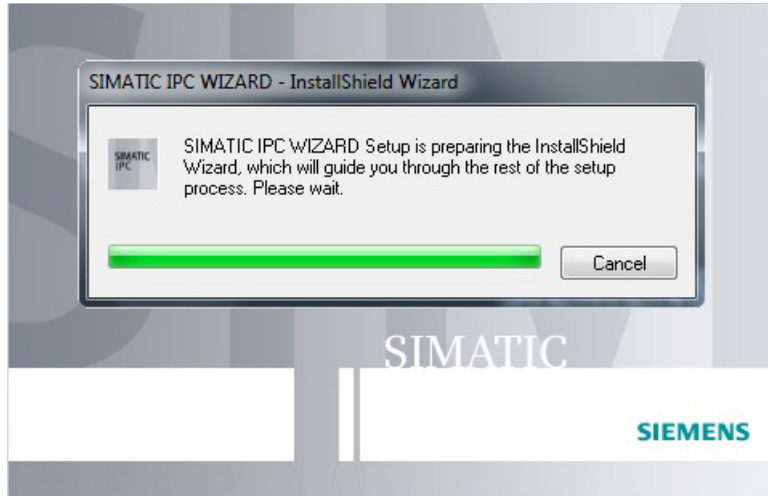

2. Follow the instructions.

The SIMATIC IPC Wizard recognizes the existing hardware components and automatically installs the associated software. This operation can take several minutes.

When all software components are installed, the following dialog is displayed:

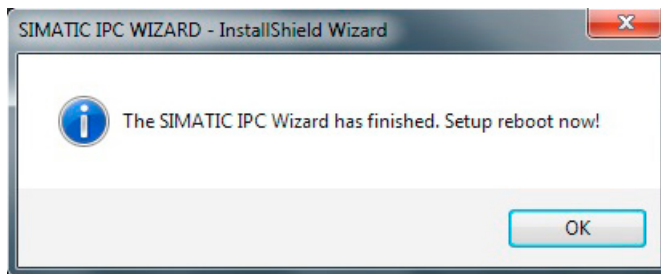

Note

In the case of server operating systems the dialog contains the "Now" and "Later" buttons instead of "OK".

3. Complete the installation with the "OK" button; for server operating systems use "Now".
The PC is restarted.

Result

You have installed the SIMATIC IPC Wizard software.

Operating the device

5.1 Operator input options

Depending on your device and the connected I/O devices, the following operator input options are available:

- Integrated keyboard on touch device
- Touch screen for touch device

<p> CAUTION</p> <p>Unintentional actions with touch screen operation</p> <p>If you touch the touch screen while system-internal processes are running, unintended reactions of the device may be triggered.</p> <p>Do not touch the screen in the following situations:</p> <ul style="list-style-type: none"> • During the boot process • When plugging or unplugging USB components • While Scandisk is running • During a BIOS update
<p>NOTICE</p> <p>Damage to the touch screen</p> <p>Hitting the touch screen with hard objects may damage it and can result in a total failure of the touch screen.</p> <p>Only touch the touch screen with your fingers or a suitable touch stylus.</p>

- On-screen keyboard with touch device (see section "Using the on-screen keyboard")
- External keyboard, connected via USB
- External mouse, connected via USB

5.2 Operating a device with resistive single touch screen

When you touch an object on the single touch screen, the corresponding function is performed.

WARNING

Personal injury or property damage due to incorrect operation

Incorrect operation of devices with a touch screen can occur. This can result in personal injury or property damage.

Take the following precautions:

- Configure the plant so that safety-related functions are not operated with the touch screen.
- Always touch only a single point on the touch screen.
- Calibrate the touch screen, at the latest when the touch screen becomes inaccurate or does not respond despite repeated touches.
- Switch off the device for cleaning and maintenance.
- Make sure that the touch screen is kept free of dirt.

NOTICE

Damage to the touch screen

Touching the touch screen with pointed or sharp objects can damage it and lead to a significant reduction in service life or even total failure of the touch screen.

Do not touch the touch screen with pointed or hard objects. Only touch the touch screen with your fingers, a touch stylus or an approved touch glove.

Note

Appearance of blisters under extreme ambient conditions

Under extreme environmental conditions such as high atmospheric humidity and temperature, bubbles can form on the touch surface in rare cases. This only affects the appearance and does not represent any functional restriction.

5.3 Operating a device with capacitive multi-touch screen

You operate the multi-touch screen with one or multiple fingers. You can also operate it using gestures with up to five fingers at a time.

WARNING

Personal injury or property damage due to no earth connection

An inadequate earth connection or the lack of one may cause malfunction of the capacitive touch screen. Functions may not work properly. This can result in personal injury or property damage.

- Always connect the device to an earth conductor.
- The earth conductor from the device must be connected directly to earth with low impedance (short connection, minimum cross-section 2.5 mm²).

You can find additional information on connecting the earth conductor in the section "Connecting the protective earth (Page 36)".

WARNING

Personal injury or property damage due to maloperation

Incorrect operation of devices with a touch screen can occur. This can result in personal injury or property damage.

Take the following precautions:

- Configure the plant so that safety-related functions are not operated with the touch screen.
- Switch off the device for cleaning and maintenance.

WARNING

Danger of malfunction due to improper execution of gestures on the touch screen

If gestures are executed incorrectly on the touch screen with multi-touch function, these gestures may not be recognized or could be recognized incorrectly. The entries made are then not implemented by the device or are implemented incorrectly or in an unintended manner.

Incorrect execution of multi-touch functions can lead to errors in the operation of the plant and thus to physical injury.

Note the following when operating the touch screen with multi-touch function:

- The touch screen reacts to contact on its surface, not to pressure.
- When using a touch pen: Operate the touch screen only with a touch pen for capacitive touch.
- Avoid unintended multiple touches, for example, with your knuckles.

Before you start to operate the device, make sure you are familiar with the multi-touch functions of the Windows operating system, as well as with the application to be used and its functions. Ensure that the gestures which the user executes on the multi-touch display are recognized by the application. It is possible that certain gestures need to be trained beforehand.

Notes on operation

Note when operating the multi-touch screen:

- Surface contact with a diameter of about 5 to 20 mm is required for an operator action to be detected.
- An operation with gloves with a material thickness of <2 mm is detected in most cases. However, check the usefulness of the gloves you are using.
- To avoid incorrect operation, certain inputs are ignored and blocked from further entry:
 - Simultaneous operation with more than 5 fingers.
 - Surface contact with a diameter of > 3 cm, for example, resting the palm of the hand on the touch screen
 - As soon as the touch screen is no longer touched, input is possible again.

Functions of the multi-touch screen

General functions

- Detection of up to 5 finger touches at a time.
- Detection of gestures that are supported by the operating system or the software installed on the device.

Note

Multi-touch operation can provide advanced features or pose limitations depending on the operating system and the software installed on the device. Read the corresponding documentation.

- You do not need to calibrate the touch screen. Some operating systems do offer touch calibration. However, this calibration does not lead to improved accuracy.

Security functions in an industrial environment

The touch screen is locked for security reasons when following happens:

- There is a conductive liquid on the touch screen with ground contact via the enclosure or the operator, for example.
- Electromagnetic interference is present that exceeds the specification according to EN 61000-4-2.

Once the interference is over, the touch screen is no longer locked.

5.4 Operating a Touch/Key device

Note

Maloperation

If you activate several keys simultaneously, a malfunction on the device cannot be excluded. Only press the function keys one after the other.

Malfunctions of the user software

Always use security features of the KeyTools for security reasons. If you disable them, nevertheless, serious malfunctions of the user software may occur when the additional function keys F1 to F36 are used or if custom key code tables are used.

Risk of damage

Activating a key using a hard or pointed object, for example a screwdriver, reduces the life of the key or can damage it.

External keyboard

Note

The keyboard layout has been set to "English/USA international". If you use a keyboard with a layout other than the "English/USA international" layout, the key codes of the internal and external keyboards might no longer correspond.

This section describes the keyboard assignment of the device in the delivery state.

The assignment of the keys, including the function keys and control of the LEDs, is specified by means of the SIMATIC IPC KeyTools which is installed with the SIMATIC IPC Wizard.

You will find the SIMATIC IPC Wizard operating manual:

- On the "Documentation and Drivers" CD/DVD included in the delivery
- In the IPC Wizard installation folder on the PC after successful installation of the IPC Wizard

Alphanumeric keys





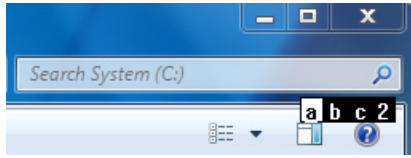







Key	Assignment lower case LED "a/A" inactive	Assignment upper case LED "a/A" active	Assignment SHIFT level LED "a/A" active or inactive
1	<space>\@#%?!";;<>(){}€\$&%^°~ _1	<space>\@#%?!";;<>(){}€\$&%^°~ _!	<space>\@#%?!";;<>(){}€\$&%^°~ _!
2	abc2	ABC2	ABC@
3	def3	DEF3	DEF#
4	ghi4	GHI4	GHI\$
5	jkl5	JKL5	JKL%
6	mno6	MNO6	MNO^
7	pqrs7	PRQRS7	PQRS&
8	tuv8	TUV8	TUV*
9	wxyz9	WXYZ9	WXYZ(
0		+_*/=0	+_*?+)
.,	.,	.,	><

The characters available for input depend on the text box involved. The figure below shows the entry of an alphanumeric value using the system keys:







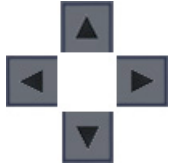

Control keys

The following table describes the control keys and their associated functions. With keyboard shortcuts, hold the first key down. Then press the second button.

Key or keyboard shortcut	Function
	Switch between upper and lower case: <ul style="list-style-type: none"> • LED on: Upper case • LED off: Lower case
	Deletes the character left of cursor.
	Tabulator
	Deletes the character to the right of the cursor or the highlighted text.
 	Toggles "overwrite" mode on or off. If "overwrite" mode is switched on, the characters are overwritten to the right of the cursor.
	Open the TIA help, for example, from WinCC The user software can specifically react to the stored key code. You can control the LED by means of the LEDControl program of the IPC Wizard.
	Cancel
	Press: Switches to an additional white key assignment. Hold down: Switches between upper and lower case.
	Acknowledge The user software can specifically react to the stored key code. You can control the LED by means of the LEDControl program of the IPC Wizard.
	General control function for use in keyboard shortcuts.
	General control function for use in keyboard shortcuts.
	Confirm input

Cursor keys

Key or keyboard shortcut	Function
	Moves the cursor, selection or a controller in the specified direction.
	Moves the cursor or selection one page up.
	Moves the cursor or selection one page down.
 	Moves the cursor to the start of the first screen.
 	Moves the cursor to the end of the last screen.

5.5 IPC Wizard functions

Software components

- General for all devices: Panel PC Tools
 - SetBrightness
 - IPCScreenSaver
- Special for devices with resistive single-touch screen: UPDD (Universal Pointing Device Driver) with the following features
 - Advanced touch features
 - Calibrating
- Calibration is not necessary for devices with capacitive multi-touch screen. Depending on your operating system, you may be able calibrate the touch screen through the operating system, although it will not improve the accuracy.

All other functions are described in the manual "SIMATIC IPC Wizard 2.1 and Panel Configuration Center":

- On the "Documentation and Drivers" CD/DVD included in the delivery
- In the IPC Wizard installation directory on the PC

Maintaining and servicing your device

6.1 Cleaning the device

Scope of maintenance

When working in areas where there is dust that may be hazardous to functionality, the device must be operated in a control cabinet with a heat exchanger or with suitable supply air.

Note

The dust deposits must be removed at appropriate time intervals.

Cleaning agents

Use dish soap or foaming screen cleaner only as cleaning agents.

NOTICE
Do not clean the device with aggressive solvents or scrubbing agents or with pressurized air or steam cleaner.

Procedure

1. Switch off the device. This prevents the accidental triggering of functions when the screen is touched.
2. Dampen the cleaning cloth.
3. Spray the cleaning agent on the cloth and not directly on the device.
4. Clean the device with the cleaning cloth.

6.2 Spare parts and repairs

 **WARNING**

Risk of bodily injury or equipment damage due to unauthorized opening or repairing

Bodily injury or considerable equipment damage may result from the unauthorized opening or repairing of the device. Do not carry out any repairs on your own. Repairs may only be carried out by authorized qualified personnel at the manufacturer's site.

For repairs, send the device to the Return Center in Fürth. Repairs may only be carried out at the Return Center in Fürth.

Depending on the work necessary to repair the device, the Center may decide to give you a credit note. In this case, it is your responsibility to order a new device.

The address is:

Siemens AG
Industry Sector
Returns Center
Siemensstr. 2
90766 Fürth Germany

See also

Spare parts and repairs (<http://support.automation.siemens.com/WW/view/en/16611927>)

6.3 Recycling and disposal

The devices described in these operating instructions can be recycled thanks to their low level of pollutants. Contact a certified disposal service company for environmentally sound recycling and disposal of your old devices.

Technical information

7.1 Certificates and approvals

Note

Approvals on the rating plate

The following overview provides information on possible approvals.
Only the approvals on the rating plate (Page 72) of the specific device apply.

CE marking



The devices meet the general and safety-related requirements of the following EC directives and conform to the harmonized European standards (EN) for these devices published in the official gazettes of the European Community:

- 2006/95/EC "Electrical equipment for use within specific voltage limits" (Low-Voltage Directive)
- 2004/108/EC "Electromagnetic Compatibility" (EMC Directive)
- 94/9/EC "Devices and protection systems for use as prescribed in potentially explosive areas" (Guidelines for Explosion Protection)

EC Declaration of Conformity

The EC Declarations of Conformity are available to the relevant authorities at the following address:

Siemens Aktiengesellschaft
Industry Sector
I IA AS FA WF AMB
PO Box 1963
D-92209 Amberg, Germany

You can download information on the EC Declaration of Conformity, here under the keyword "Declaration of Conformity":

Certificate Industrial Flat Panel
(<http://support.automation.siemens.com/WW/view/en/60242448/134200>).

Software license agreements

If the device is supplied with preinstalled software, you must observe the corresponding license agreements.

UL approval



Underwriters Laboratories Inc., to

- UL 508 (Industrial Control Equipment)
- CSA C22.2 No. 142 (Process Control Equipment)

or



Underwriters Laboratories Inc., to

- UL 508 (Industrial Control Equipment)
- CSA C22.2 No. 142 (Process Control Equipment)
- ANSI/ISA 12.12.01 (Hazardous Location)
- CSA-213 (Hazardous Location)

Approved for use in

- Class I, Division 2, Group A, B, C, D or
- Class I, Zone 2, Group IIC or
- non-hazardous locations

FM Approval



Factory Mutual Research (FM) conforming to

- Approval Standard Class Number 3611, 3600, 3810, ANSI/ISA 61010-1
- CSA C22.2 No. 213
- CSA C22.2 No. 1010.1

Approved for use in

- Class I, Division 2, Group A, B, C, D T4
- Class I, Zone 2, Group IIC T4

Ex approval

The following approvals apply to the device in accordance with

- IEC 60079-0:2011 and EN 60079-0:2012
- IEC 60079-15:2010 and EN 60079-15:2010
- IEC 60079-31: 2008 and EN 60079-31:2009

valid:

	II 3 G	Ex nA IIC Tx Gc
	II 3 D	Ex tc IIIC T 70 °C Dc IP65 x: Temperature values, see EC design examination certificate

The EC type examination certificates are available on the Internet at:

Technical Support (http://www.siemens.de/automation/csi_en_WW)

The table below describes the test numbers of the HMI device classes:

Manufacturer site	HMI device class	Test number
Siemens AG Industry Sector Werner-von-Siemens-Straße 50 D-92209 Amberg, Germany	Comfort Panel, ITC, IFP	DEKRA11ATEX0005X IECEX DEK 13.0085X

FCC and Canada

USA	
Federal Communications Commission Radio Frequency Interference Statement	This equipment has been tested and found to comply with the limits for a Class A digital device, pursuant to Part 15 of the FCC Rules. These limits are designed to provide reasonable protection against harmful interference when the equipment is operated in a commercial environment. This equipment generates, uses, and can radiate radio frequency energy and, if not installed and used in accordance with the instruction manual, may cause harmful interference to radio communications. Operation of this equipment in a residential area is likely to cause harmful interference in which case the user will be required to correct the interference at his own expense.
Shielded Cables	Shielded cables must be used with this equipment to maintain compliance with FCC regulations.
Modifications	Changes or modifications not expressly approved by the manufacturer could void the user's authority to operate the equipment.
Conditions of Operations	This device complies with Part 15 of the FCC Rules. Operation is subject to the following two conditions: (1) this device may not cause harmful interference, and (2) this device must accept any interference received, including interference that may cause undesired operation.

CANADA	
Canadian Notice	This Class A digital apparatus complies with Canadian ICES-003 (B).
Avis Canadien	Cet appareil numérique de la classe A est conforme à la norme NMB-003 (B) du Canada.

AUSTRALIA / NEW ZEALAND



This product meets the requirements of EN 61000-6-4:2007 Generic standards - Emission standard for industrial environments.

This product meets the requirements of the standard EN 61000-6-4:2007 Generic standards – Emission standard for industrial environments.

KOREA



This product meets the requirements of Korean certification.

This product satisfies the requirement of the Korean Certification (KC Mark).

이 기기는 업무용(A급) 전자파 적합기기로서 판매자 또는 사용자는 이 점을 주의하시기 바라며 가정 외의 지역에서 사용하는 것을 목적으로 합니다.

Marine approvals

Acceptance procedures for shipping and offshore applications in preparation:

- ABS American Bureau of Shipping (USA)
- BV Bureau Veritas (France)
- DNV Det Norske Veritas (Norway)
- GL Germanische Lloyd
- LR Lloyds Register of Shipping
- Class NK Nippon Kaiji Kyokai (Japan)

7.1.1 Programmable logic controllers

IEC 61131 programmable logic controllers

The devices meet the requirements and criteria of the IEC 61131-2 standard: Programmable Logic Controllers – Part 2: Operating resource requirements and tests.

7.2 Directives and declarations

7.2.1 ESD guideline

What does ESD mean?

An electronic module is equipped with highly integrated components. Due to their design, electronic components are highly sensitive to overvoltage and thus to the discharge of static electricity. Such electronic components or modules are labeled as electrostatic sensitive devices.

The following abbreviations are commonly used for electrostatic sensitive devices:

- ESD – Electrostatic sensitive device
- ESD – Electrostatic Sensitive Device as a common international designation

Electrostatic sensitive devices can be labeled with an appropriate symbol.



NOTICE

Damage to ESD from touch

Electrostatic sensitive devices, ESD, can be destroyed by voltages which are far below the human perception limit. If you touch a component or electrical connections of a module without discharging any electrostatic energy, these voltages may arise.

The damage to a module by an overvoltage can often not be immediately detected and only becomes evident after an extended period of operation. The consequences are incalculable and range from unforeseeable malfunctions to a total failure of the machine or system.

Avoid touching components directly. Make sure that persons, the workstation and the packaging are properly grounded.

Charge

Every person without a conductive connection to the electrical potential of his/her surroundings can be electrostatically charged.

The material with which this person comes into contact is of particular significance. The figure shows the maximum electrostatic voltages with which a person is charged, depending on humidity and material. These values conform to the specifications of IEC 61000-4-2.

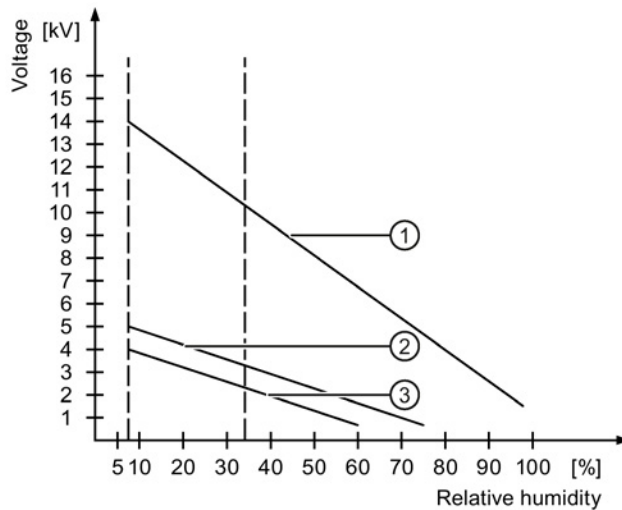

- ① Synthetic materials
- ② Wool
- ③ Antistatic materials such as wood or concrete

NOTICE

Grounding measures

There is no equipotential bonding without grounding. An electrostatic charge is not discharged and may damage the ESD.

Protect yourself against discharge of static electricity. When working with electrostatic sensitive devices, make sure that the person and the workplace are properly grounded.

Protective measures against discharge of static electricity

- Disconnect the power supply before you install or remove modules which are sensitive to ESD.
- Pay attention to good grounding:
 - When handling electrostatic sensitive devices, make sure that persons, the workstation and devices, tools and packaging used are properly grounded. This way you avoid static discharge.
- Avoid direct contact:
 - As a general rule, do not touch electrostatic sensitive devices, except in the case of unavoidable maintenance work.
 - Hold the modules at their edge so that you do not touch the connector pins or conductor paths. This way, the discharge energy does not reach and damage the sensitive components.
 - Discharge your body electrostatically before you take a measurement at a module. Do so by touching grounded metallic parts. Always use grounded measuring instruments.

7.2.2 Electromagnetic compatibility

Pulse-shaped interference

The Industrial Flat Panels have been tested for high-energy single pulse (surge) in accordance with IEC 61000-4-5.

An external protective circuit is required for operation with 24 VDC; please refer to the chapter "Lightning and Surge Voltage Protection" in the "S7-300 Automation System, Hardware and Installation" installation manual. The "S7-300 Automation System, Hardware and Installation" installation manual is available for download from the Internet (<http://support.automation.siemens.com/WW/view/en/15390415>).

The following lightning protection element was used during the testing of the Industrial Flat Panel:

Dehn BVT AVD 24" (Order No. 918 422)

7.3 Dimension drawings

7.3.1 Dimension drawing of the IFP1500 Multitouch

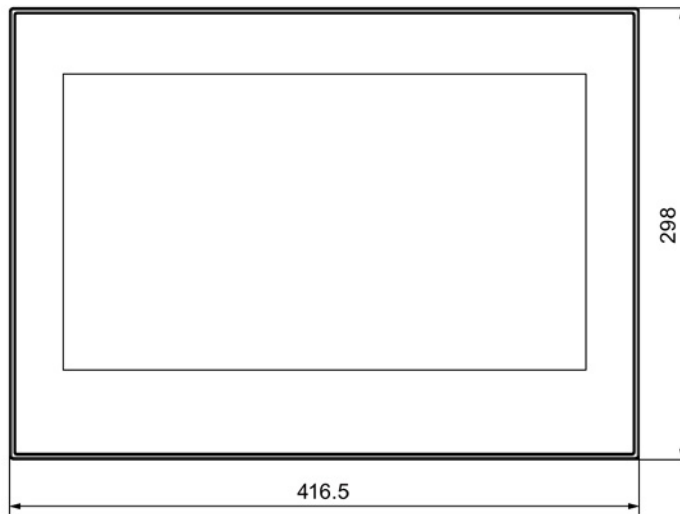
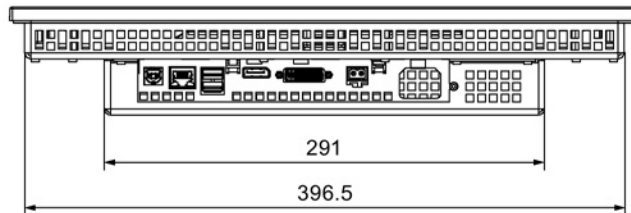

All dimensions in mm

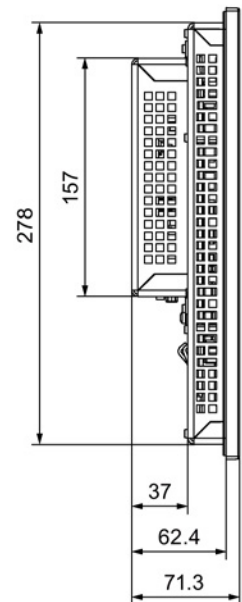

7.3.2 Dimension drawing of the IFP1500 Monitor and Touch

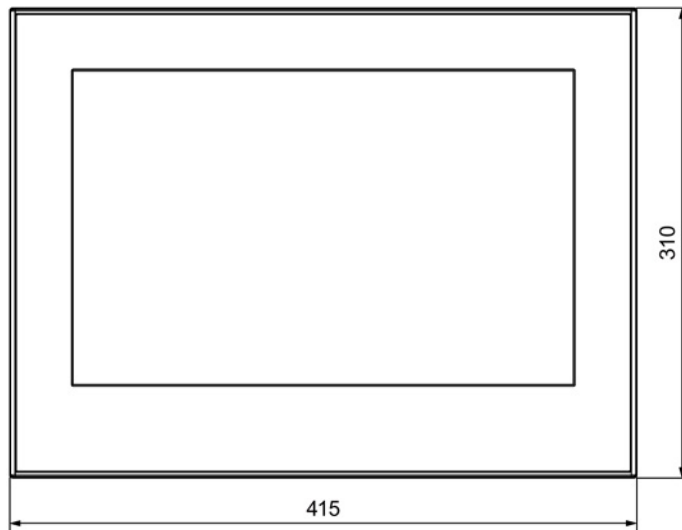
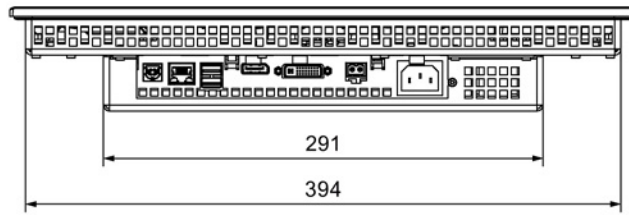

All dimensions in mm

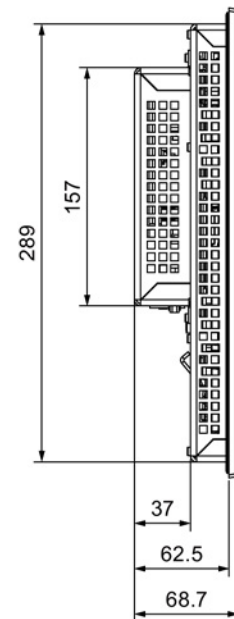

7.3.3 Dimension drawing of the IFP1900 Multitouch

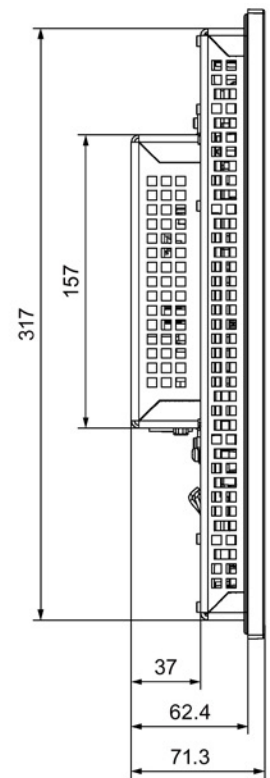
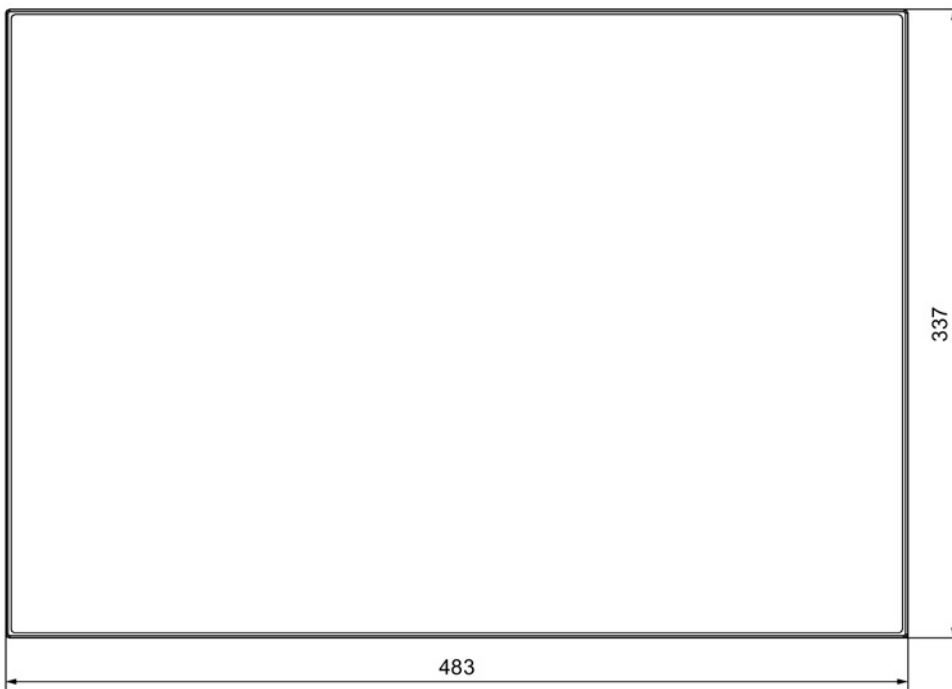
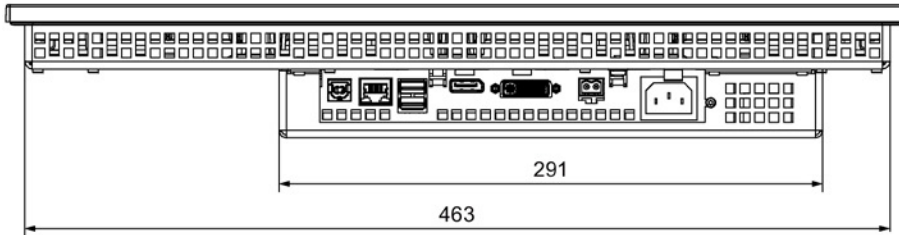

All dimensions in mm

7.3.4 Dimension drawing of the IFP1900 Monitor and Touch

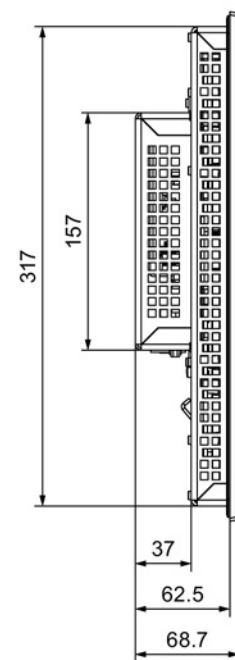
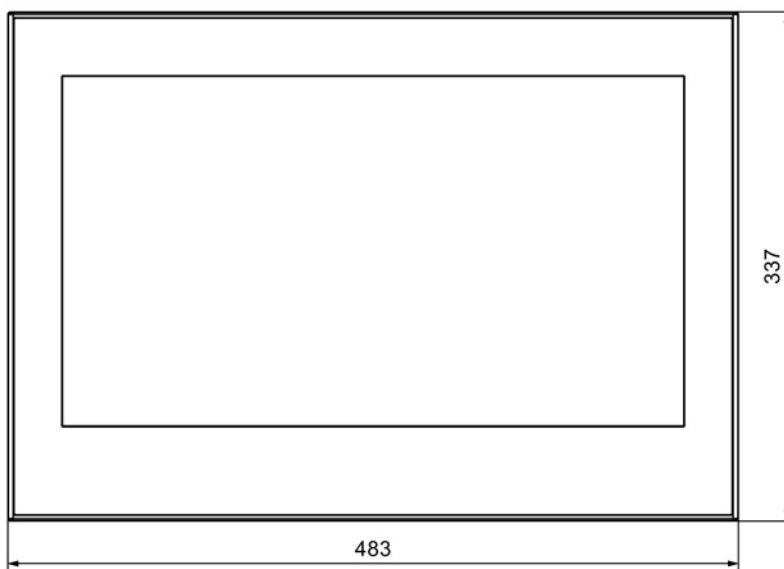
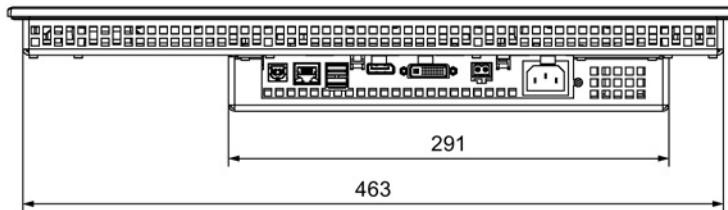

All dimensions in mm

7.3.5 Dimension drawing of the IFP2200 Multitouch

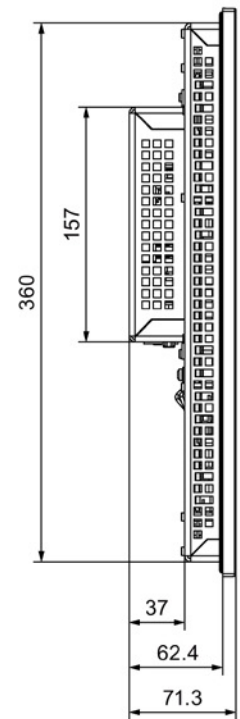
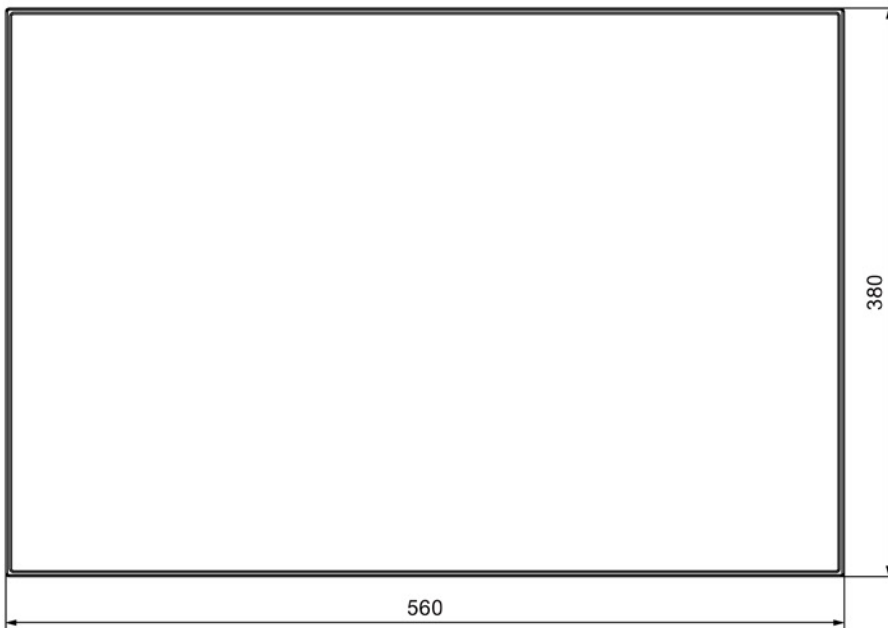
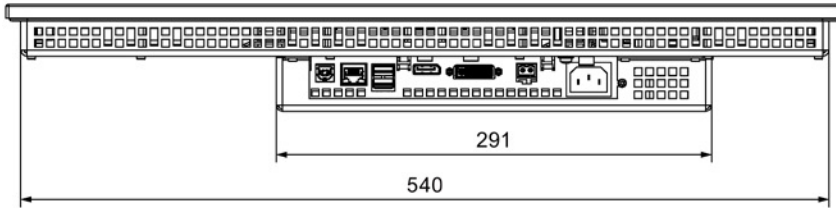

All dimensions in mm

7.3.6 Dimension drawing of the IFP2200 Monitor and Touch

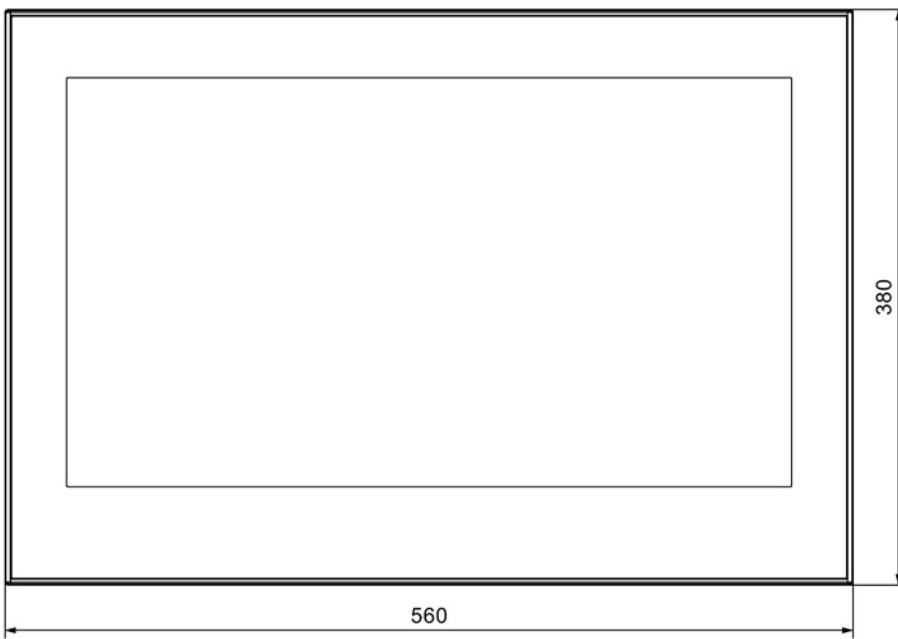
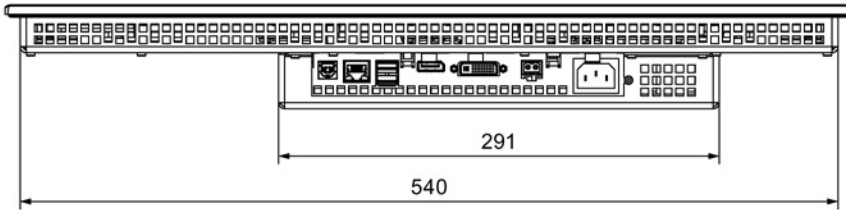

All dimensions in mm

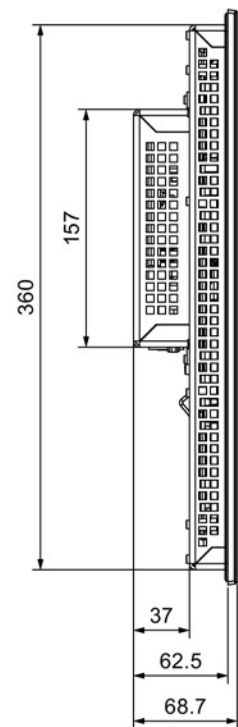

7.3.7 Dimension drawing of the IFP1500 Touch/Key

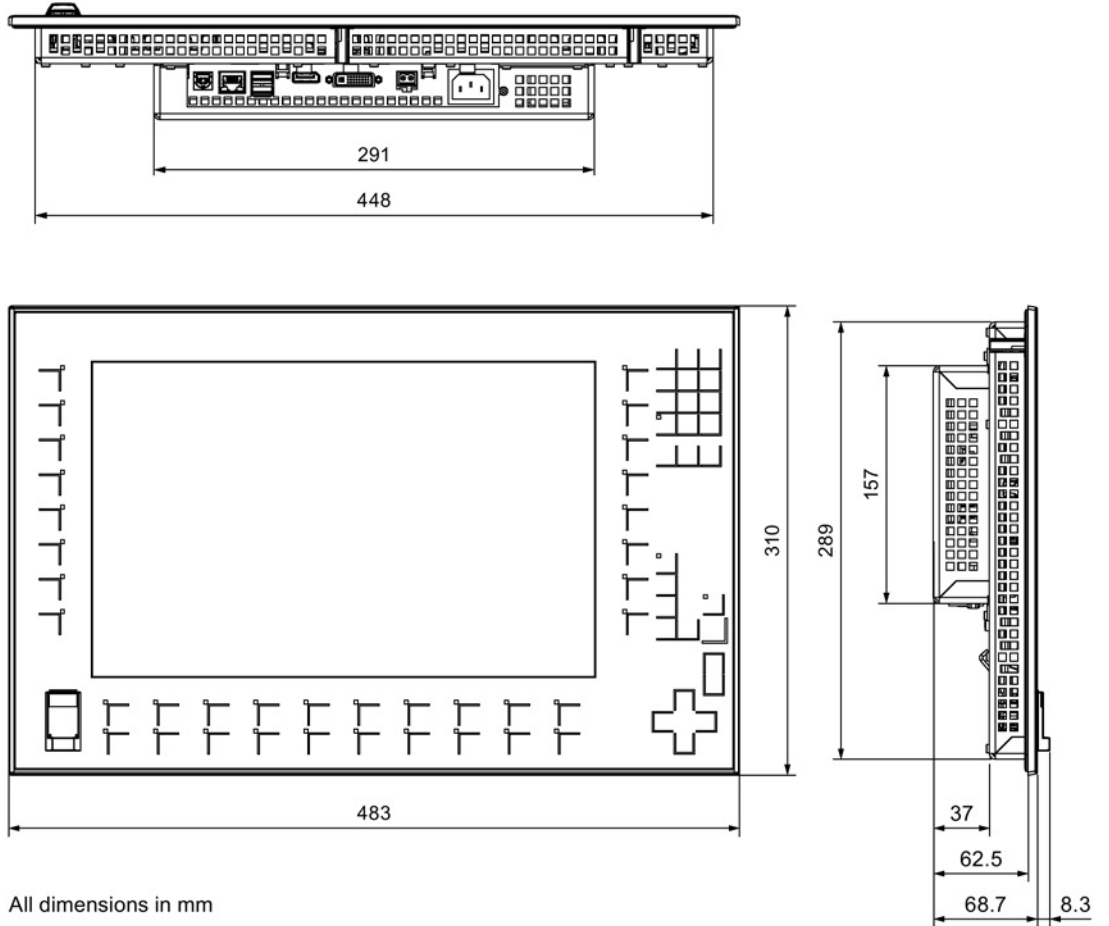

All dimensions in mm

7.3.8 Dimension drawing Host Unit USB

The Host Unit USB is available as an accessory (DVI/USB cable sets >5 m).

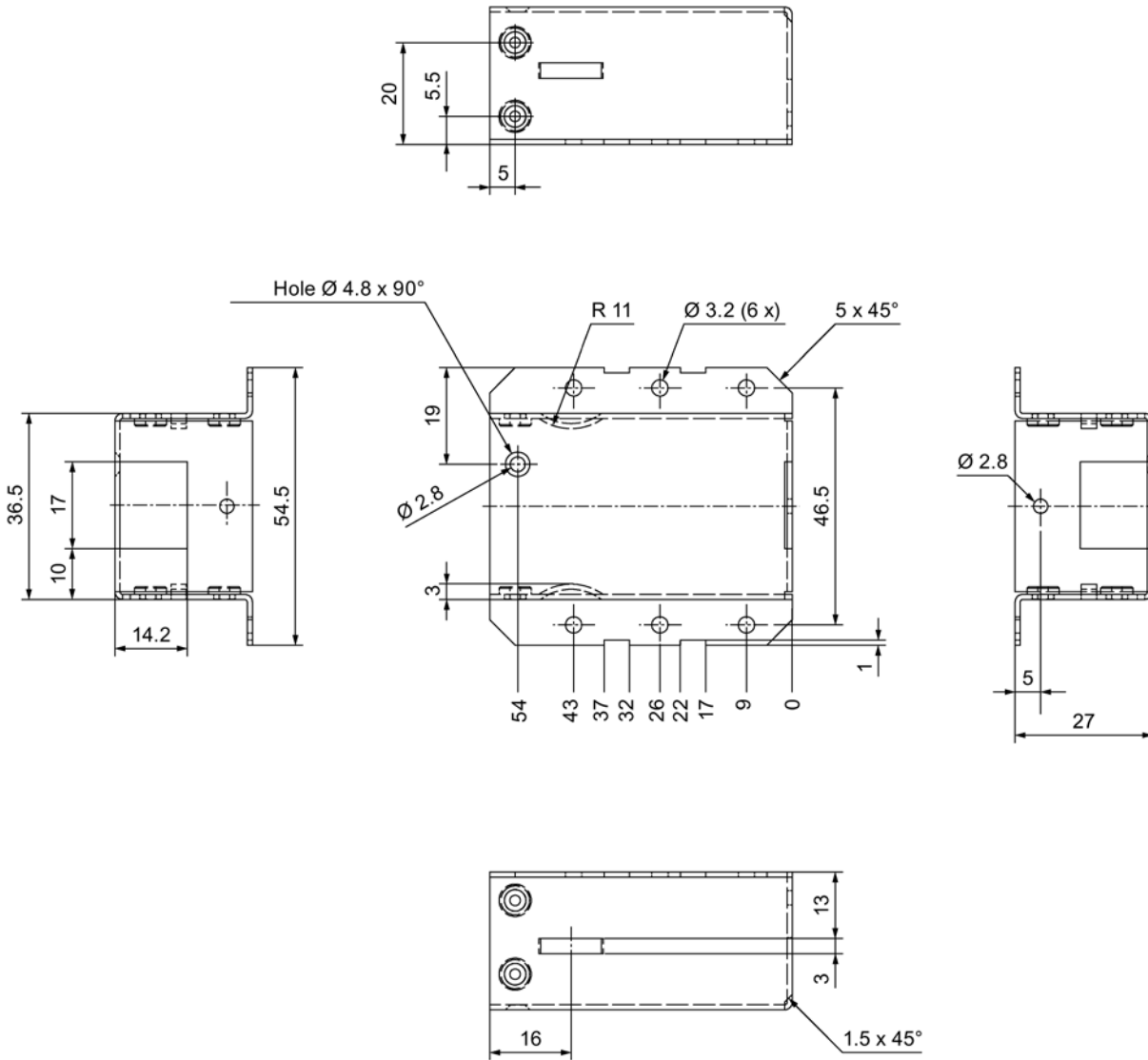

7.3.9 Dimensions for labeling strips

This section contains the dimensions of the labeling strips for 15" widescreen devices.

Labeling strip templates are available in a Word document on the Internet at:

Labeling strips for 15" widescreen

(<http://support.automation.siemens.com/DE/view/en/59000814>)

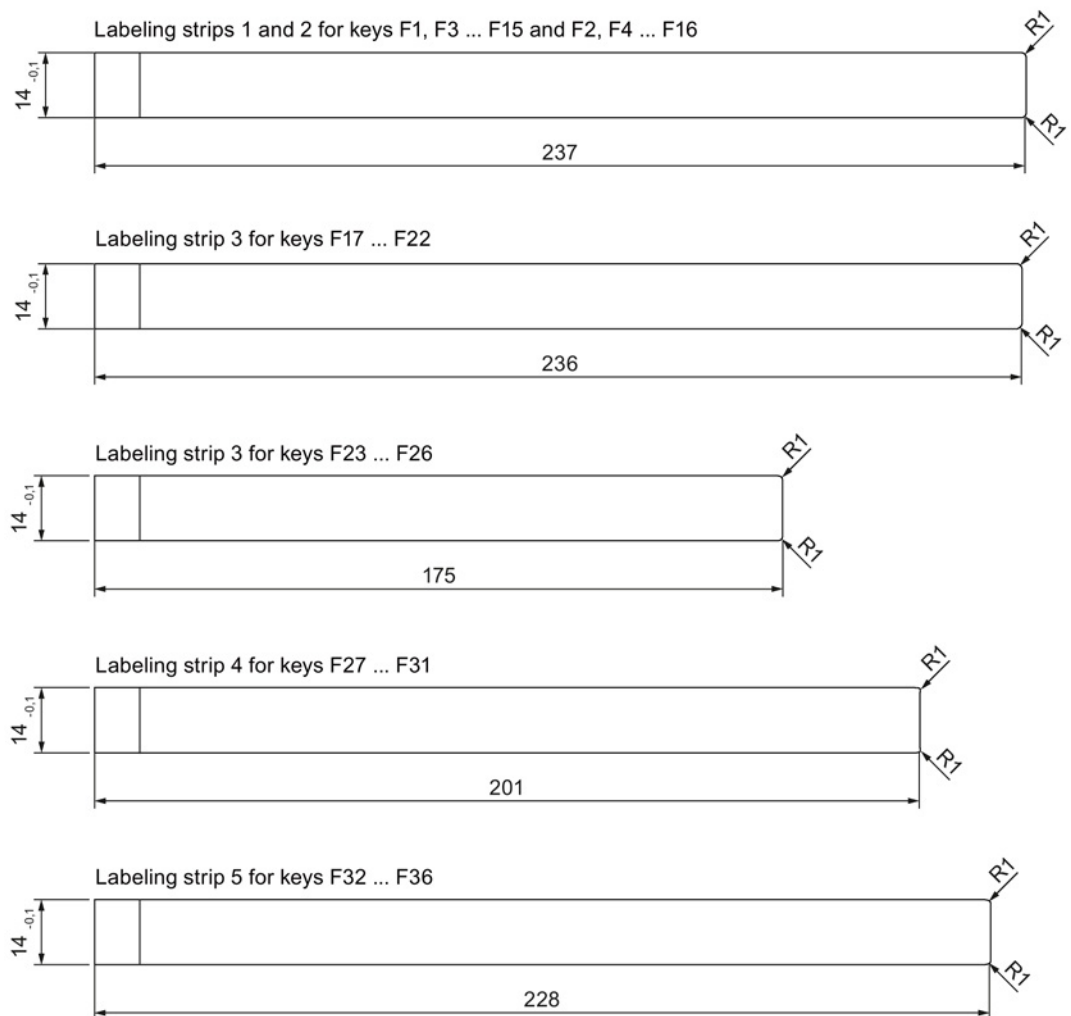

7.4 Rating plate

The rating plate includes information that clearly identifies your device. You need this information when you contact Customer Support.

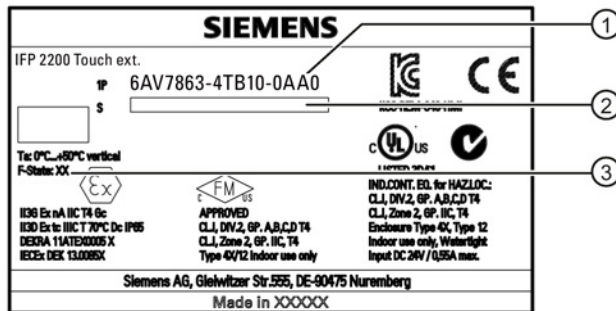

- ① Order number
- ② Serial number
- ③ Production version

7.5 Technical specifications

7.5.1 General technical specifications

Weight

	IFP1500 ¹	IFP1500 ²	IFP1900	IFP1900 Multitouch	IFP2200	IFP2200 Multitouch	IFP1500 Touch/Key
Weight without packaging	3.9 kg	4.2 kg	5.5 kg	5.8 kg	6.5 kg	6.7 kg	4.3 kg

Display

	IFP1500 ¹	IFP1500 ²	IFP1900	IFP2200
Type	LCD widescreen TFT			
Active display area	15.4" 331.2 × 207 mm	15.6" 344.2 × 193.5 mm	18.5" 409.8 × 230.4 mm	21.5" 475.2 × 267.3 mm
Resolution	1280 x 800 pixels	1366 x 768 pixels	1366 x 768 pixels	1920 x 1080 pixels
Possible colors	Up to 16 million			
Brightness control	By means of SetBrightness tool, value range 10% to 100%			
Backlighting	LED	LED	LED	LED
Half Brightness Life Time (MTBF ³)	80000 h	70000 h	50000 h	30000 h
Pixel error class in accordance with ISO 9241-307	I			

¹ resistive touch screen only

² capacitive touch screen only

³ MTBF: Operating hours after which the maximum screen brightness is reduced by half compared to the original value. MTBF is increased by using the integrated dimming function, for example time-controlled via screen saver or centrally via PROFlenergy.

Input device

	Monitor standard versions	Touch standard versions	Touch Extended versions	IFP1500 Touch/Key
Keyboard	No	On-screen keyboard	<ul style="list-style-type: none"> On-screen keyboard Externally via USB 	<ul style="list-style-type: none"> On-screen keyboard Externally via USB Device keys
Analog resistive single touch screen	No	Yes		
Capacitive multi-touch screen	No	Yes ¹		No
Function keys	No			36
Labeling strips	No			Yes

¹ not with 15" devices

Interfaces

	Monitor standard versions	Touch standard versions	Touch Extended versions	IFP1500 Touch/Key
DVI-D	Yes			
DisplayPort	Yes			
USB Type A, rear ¹	No		2	1
USB Type A, front ¹	No			1
USB Type B, host	No	1		
USB Link, RJ45	No		1	

¹ USB type A, maximum load 500 mA, equivalent to USB standard 2.0

DC power supply

	IFP1500	IFP1900	IFP2200
Rated voltage	24 V DC		
Permitted voltage range	+19.2 V to +28.8 V		
Rated current	2.0 A		2.5 A
Inrush current I _{2t}	0.5 A ² s		
Power consumption, typical	40 W		
Maximum permitted transients	35 V (500 ms)		
Minimum time between two transients	50 s		
Internal protection	Electronic		

AC power supply

	Extended versions
Rated voltage	230 V AC
Permitted voltage range	100 ... 240 V
Rated current	200 mA
Inrush current I ² t	0.5 A ² s
Power consumption, typical	40 W
Minimum time between two transients	50 s
Internal protection	Electronic

7.5.2 Ambient conditions

7.5.2.1 Transport and storage conditions

Mechanical and climatic conditions for transportation and storage

The requirements regarding transport and storage conditions for the device are more stringent than those laid down in IEC 60721-3-3. The following requirements apply to the transport and storage of the device in its original packaging.

The climatic conditions conform to:

- Class 3M3 (mechanical requirements)
- Class 3K3 (climatic requirements)

Type of condition	Permitted range
Drop test (in transport package)	≤ 1 m
Temperature	From -20 to +60° C
Atmospheric pressure	From 1080 to 660 hPa, Corresponds to an elevation of -1 000 to 3 500 m
Relative humidity	From 10 to 90%, without condensation
Sinusoidal vibration in accordance with IEC 60068-2-6	5 to 8.4 Hz: 3.5 mm 8.4 to 500 Hz: 9.8 m/s ²
Shock in accordance with IEC 60068-2-27	25 g, 6 ms, 1 000 shocks

Proper transport and storage, installation and assembly as well as careful operation and maintenance are prerequisites for trouble-free and safe operation of the device.

Non-compliance will render the warranty for the device null and void.

7.5.2.2 Operating conditions

Mechanical and climatic conditions of use

The device is designed for use in locations protected from the effects of the weather. The conditions of use meet the requirements for DIN IEC 60721-3-3:

- Class 3M3 (mechanical requirements)
- Class 3K3 (climatic requirements)

Use with additional measures

The device should not be used at the following locations unless additional measures are taken:

- In locations with a high degree of ionizing radiation
- In locations with severe operating conditions, for example, due to:
 - Corrosive vapors, gases, oils or chemicals
 - Electrical or magnetic fields of high intensity
- In systems that require special monitoring - for example:
 - Elevators
 - Systems in especially hazardous rooms

Mechanical ambient conditions

The mechanical ambient conditions for the device are specified in the table below in terms of sinusoidal vibration.

Frequency range f in Hz	Constant	Occasional
$5 \text{ Hz} \leq f \leq 8.4 \text{ Hz}$	Amplitude 0.0375 mm	Amplitude 3.5 mm
$8.4 \text{ Hz} \leq f \leq 150 \text{ Hz}$	Constant acceleration 0.5 g	Constant acceleration 1 g

Reducing vibrations

If the device is subjected to greater shocks or vibrations, you must take appropriate measures to reduce acceleration or amplitudes.

We recommend mounting the device on damping materials, such as rubber-metal vibration dampers.

Testing mechanical ambient conditions

The table below provides information on the type and scope of tests for mechanical ambient conditions.

Tested for	Test standard	Comments
Vibrations	Vibration test in accordance with IEC 60068, part 2-6 (sinusoidal)	Type of vibration: Frequency cycles at a rate of change of 1 octave/minute. 5 Hz ≤ f ≤ 8.4 Hz, constant amplitude 3.5 mm 8.4 Hz ≤ f ≤ 150 Hz, constant acceleration 1 g
		Vibration duration: 10 frequency cycles per axis in each of the three mutually vertical axes
Shock	Shock test in accordance with IEC 60068, Part 2 -27	Type of shock: Half-sine
		Severity of shock: Peak value 15 g, duration 11 ms
		Direction of shock: 3 shocks in ± direction of axis in each of the three axes vertical to each other

Climatic ambient conditions

The following table shows the climatic ambient conditions for operation of the device.

Ambient conditions	Permitted range	Comments
Temperature: Vertical mounting	From 0 to 50 °C (horizontal) ¹ From 0 to 40 °C (vertical)	
Mounting at an angle	From 0 to 40 °C (horizontal) From 0 to 35 °C (vertical)	Slope angle max. 35°
Relative humidity	10 to 90%, without condensation	
Atmospheric pressure	1 080 to 795 hPa	Corresponds to an elevation of -1000 m to 2000 m
Pollutant concentration	SO ₂ : < 0.5 vpm; Relative humidity <60%, no condensation	Test: 10 cm ³ /m ³ ; 10 days
	H ₂ S: < 0.1 vpm; Relative humidity <60%, no condensation	Test: 1 cm ³ /m ³ ; 10 days

¹ IFP1900 and IFP2200: From 0 to 45° C

Pulse-shaped interference

The following table shows the electromagnetic compatibility of modules with regard to pulse-shaped interference. This requires the device to meet the specifications and directives for electrical installation.

Pulse-shaped interference	Test voltage	Degree of severity
Electrostatic discharge in accordance with IEC 61000-4-2	Air discharge: 8 kV Contact discharge: 6 kV	3
	Contact discharge: 4 kV	2
Bursts (high-speed transient interference) in accordance with IEC 61000-4-4	2 kV power supply cable 2 kV signal cable, > 30 m 1 kV signal cable, < 30 m	3
High-power surge pulses in accordance with IEC 61000-4-5, external protective circuit required (refer to S7-300 PLC, Installation, chapter "Lightning and overvoltage protection").		
Asymmetrical coupling	2 kV power supply cable DC voltage with protective elements ¹ 2 kV signal/data cable, > 30 m, with protective elements as required ¹	3
Symmetrical coupling	1 kV power supply cable DC voltage with protective elements ¹ 1 kV signal cable, > 30 m, with protective elements as required ¹	3

¹ The following lightning protection element was used during the testing of the Industrial Flat Panel: Dehn BVT AVD 24" (Order No. 918 422)

Sinusoidal interference

The following table shows the EMC behavior of the modules with respect to sinusoidal interference. This requires the HMI device to meet the specifications and directives for electrical installation.

Sinusoidal interference	Test values	Degree of severity
HF radiation (electromagnetic fields) according to IEC 61000-4-3	80% amplitude modulation at 1 kHz with 10 V/m in range of 80 MHz to 1 GHz with 3 V/m in the range 1.4 GHz to 2 GHz with 1 V/m the range 2 GHz to 2.7 GHz	3
HF power applied to lines and line shields according IEC 61000-4-6	Test voltage 10 V, with 80% amplitude modulation of 1 KHz in the range of 150 KHz to 80 MHz	3

Emission of radio interference

The following table shows the unwanted emissions from electromagnetic fields in accordance with EN 55016, Limit Value Class A, Group 1, measured at a distance of 10 m.

Radiated emission (emitted interference)

From 1 GHz to 3 GHz	< 66 dB peak and < 46 dB average
From 3 GHz to 6 GHz	< 70 dB peak and < 50 dB average
From 30 to 230 MHz	< 40 dB (µV/m) quasi-peak
From 230 to 1000 MHz	< 47 dB (µV/m) quasi-peak

Emission of radio interference voltages

From 0.150 MHz to 0.5 MHz	< 79 dB quasi-peak and < 66 dB average
From 0.5 MHz to 30 MHz	< 73 dB quasi-peak and < 60 dB average

Additional measures

Before you connect a device to the public network, ensure that it is compliant with Limit Class B in accordance with EN 55022.

7.5.2.3 Information on insulation tests, protection class and degree of protection

Test voltages

Insulation strength is demonstrated in the type test with the following test voltages in accordance with IEC 61131-2:

Circuits with a nominal voltage of U_n to other circuits or ground	Test voltage
24 V	707 V DC or 500 V AC

Protection class

Protection Class I in accordance with IEC 61140, i.e. PE/ground terminal to profile rail required.

Protection against foreign objects and water

Degree of protection in accordance with IEC 60529	Explanation
Front	When mounted: <ul style="list-style-type: none"> • IP65 • Front face only Type 4X/Type 12 (indoor use only)
Rear panel	IP20 Touch protection test with standard test probes. There is no protection against ingress by water.

The degree of protection of the front panel can only be guaranteed if the mounting seal is properly installed at the mounting cut-out and the cover flap of the USB interface is closed on the Touch/Key device.

Degree of pollution / overvoltage category according to IEC 61131

- Degree of pollution 2
- Overvoltage category II

7.6 Interface description

7.6.1 24 V DC Power Supply

24 V DC power supply	
	
Pin no.	Meaning
1	+24 V DC
2	GND ¹ 24 V

¹ GND is internally connected to signal ground on DVI, for example, device ground and housing:

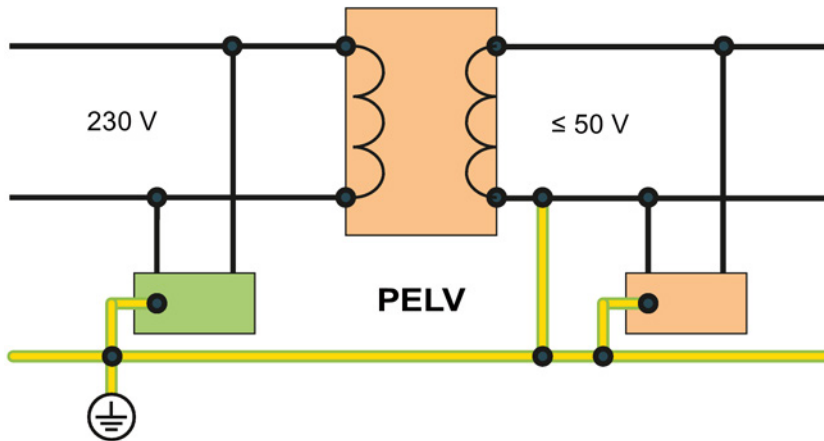
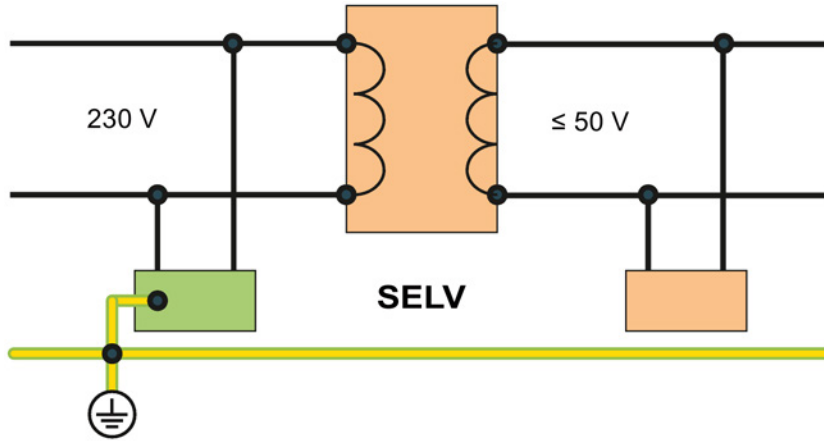

7.6.2 DVI-D interface

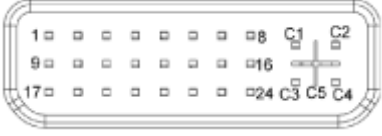
DVI-D interface		
		
Pin no.	Abbreviation	Signal
1	TX2N	TDMS data 2-
2	TX2P	TDMS data 2+
3	GND	TMDS data shield 2, ground
4	NC	Not assigned
5	NC	Not assigned
6	DDC CLK	DDC clock
7	DDC CLK	DDC data
8	NC	Not assigned
9	TX1N	TDMS data 1-
10	TX1P	TDMS data 1+
11	GND	TMDS data shield 1, ground
12	NC	Not assigned
13	NC	Not assigned
14	+5 V	+5 V power
15	GND	Ground
16	MONDET	Hotplug detect
17	TX0N	TDMS data 0-
18	TX0P	TDMS data 0+
19	GND	TMDS data shield 0, ground
20	NC	Not assigned
21	NC	Not assigned
22	GND	TMDS clock shield, ground
23	TXCP	TDMS clock +
24	TXCN	TDMS clock -
C1	NC	Not assigned
C2		
C3		
C4		
C5		

7.6.3 DisplayPort

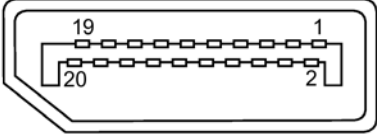
DisplayPort interface			
			
Pin no.	Abbreviation	Meaning	Input/output
1	ML_Lane3-	DP data 3-	Input
2	GND	Ground	-
3	ML_Lane3+	DP data 3+	Input
4	ML_Lane2-	DP data 2-	Input
5	GND	Ground	-
6	ML_Lane2+	DP data 2+	Input
7	ML_Lane1-	DP data 1-	Input
8	GND	Ground	-
9	ML_Lane1+	DP data 1+	Input
10	ML_Lane0-	DP data 0-	Input
11	GND	Ground	-
12	ML_Lane0+	DP data 0+	Input
13	CONFIG1 CAD	Cable Adapter Detect	Input
14	CONFIG2	Ground (PullDown)	-
15	AUX_CH+	Auxiliary channel+	Bidirectional
16	GND	Ground	-
17	AUX_CH-	Auxiliary channel-	Bidirectional
18	HPD	Hot Plug Detect	Input
19	GND	Ground	-
20	DP_PWR	+3.3 V (fused)	Input

7.6.4 USB interface, Type B

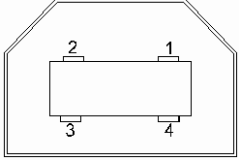
USB interface, Type B		
		
Pin No.	Abbreviation	Signal
1	VCC	+ 5 V (fused)
2	- Data	Data channel
3	+ Data	Data channel
4	GND	Ground

7.6.5 USB hub, Type A

USB port		
		
Pin No.	Short name	Signal
1	VCC	+ 5 V (fused)
2	- Data	Data channel
3	+ Data	Data channel
4	GND	Ground

Technical Support

A.1 Service and support

You can find additional information and support for the products described on the Internet at the following addresses:

- Technical support (http://www.siemens.de/automation/csi_en_WW)
- Support request form (<http://www.siemens.com/automation/support-request>)
- After Sales Information System SIMATIC IPC/PG (<http://www.siemens.com/asis>)
- SIMATIC Documentation Collection (<http://www.siemens.com/simatic-tech-doku-portal>)
- Your local representative
(<http://www.automation.siemens.com/mcms/aspa-db/en/Pages/default.aspx>)
- Training center (<http://sitrain.automation.siemens.com/sitrainworld/?AppLang=en>)
- Industry Mall (<https://mall.industry.siemens.com>)

When contacting your local representative or Technical Support, please have the following information at hand:

- MLFB of the device
- BIOS version for industrial PC or image version of the device
- Other installed hardware
- Other installed software

Tools & downloads

Please check regularly if updates and hotfixes are available for download to your device. The download area is available on the Internet at the following link:

After Sales Information System SIMATIC IPC/PG (<http://www.siemens.com/asis>)

See also

Rating plate (Page 72)

B

List of abbreviations

ANSI	American National Standards Institute
ASCII	American Standard Code for Information Interchange
B	Width
BLI	Backlight Inverter
BIOS	Basic Input Output System
CD-ROM	Compact Disc – Read Only Memory
CPU	Central Processing Unit
DC	Direct Current
DHCP	Dynamic Host Configuration Protocol
DNS	Domain Name Service
DP	Distributed I/O
DSN	Data Source Name
DVD-ROM	Digital Versatile Disc – Read Only Memory
ESD	Electrostatic Sensitive Devices
EMC	ElectroMagnetic Compatibility
H	Height
HF	High Frequency
HMI	Human Machine Interface
IF	Interface: Interface
LCD	Liquid Crystal Display: Liquid crystal display
LED	Light Emitting Diode: Light emitting diode
LPS	Limited Power Source
Mbps	Megabits per second
OSD	OnScreenDisplay
OSK	OnScreenKeyboard
PC	Personal Computer
PG	Programming device
PPI	Point to Point Interface SIMATIC S7
PS/2	Personal System 2
RoHS	Restriction of the use of certain hazardous substances in electrical and electronic equipment
PLC	Programmable logic controller
T	Device depth
TCP/IP	Transmission Control Protocol/Internet Protocol
USB	Universal Serial Bus
VGA	Video Graphics Array

Glossary

Application

An application is a program which is put directly on the operating system MS-DOS or windows. An application on the PC/PG, for example, is STEP 7.

Controller

Installed hardware and software which control the functions of specific internal or external devices, e.g. the keyboard controller.

Documentation and Drivers CD/DVD

The "Documentation and Drivers" CD/DVD is included. The CD/DVD contains specific drivers and applications for the supported operating system.

Drivers

Program parts of the operating system. They adapt user program data to the specific formats required by peripheral devices, such as hard disk, monitors, and printers.

Drop-down menu

Menu bar on the upper edge of the screen. The menu items are pre-set or can be set as drop down menus or pull down menus. Drop down menus roll down as soon as the cursor is moved over the menu title. Pull down menus roll down after clicking on the title.

Hub

A term from network technology. A device which joins communication lines at a central location and provides a common connection to all devices on the network.

Interface

The connection of individual hardware elements, e.g. programmable controller, PCs, programming device, printer, or screen, by means of physical plug connectors.

Connection between different programs in order to exchange data.

Module

Modules are plug-in units for PLCs, programming devices or PCs. Modules exist, for example, as central modules, power-ons, or as mass storage.

Plug and play

Through plug and play, the computer configures itself automatically to be able to communicate with peripheral devices, e.g. screens, modems and printers. User connects a peripheral device: plug. Afterwards, the peripheral device can be used immediately. play, without having to configure the operating system manually. The plug and play PC requires both a BIOS that supports plug and play and a corresponding expansion card.

Index

A

- Abbreviations, 87
- AC power supply
 - Technical specifications, 75
- ACK key, 52
- Acknowledge key, 52
- Alphanumeric keys, 51
- ALT key, 52
- Ambient conditions
 - Climatic, 77
 - Mechanical, 76
 - Test, 77
- Approval, 57
 - Marine, 60

B

- Backspace key, 52

C

- Cables
 - Connecting, 35
- Canada, 40
- Cancel key, 52
- CE marking, 57
- Certificates, 57
- Cleaning agents, 55
- Clearance
 - Device, 24
- Climatic
 - Storage conditions, 75
 - Transport conditions, 75
- Commissioning, 43
 - Device, 43
- Components sensitive to electrostatic charge, 60
- Condensation, 22
- Connecting, 41
 - AC power supply, 39
 - DC power supply, 37
 - DVI, 41
 - PE conductor, 36
 - USB, 41
 - USB device, 41
- Connecting the PE conductor, 36

- Connection sequence, 35
- Control keys, 52
- CTRL key, 52
- Cursor key, 53
- Cursor keys, 53

D

- DC power supply
 - Technical specifications, 74
- Degree of protection, 25
 - Protection against ingress of solid foreign bodies, 79
 - Protection against water, 79
- Delete key, 52, 52
- Device
 - Clearance, 24
 - turning off, 37
- Directive
 - ESD Directive, 60
- Display, 20
 - Technical specifications, 73
- DisplayPort interface, 82
- Disturbance
 - Pulse-shaped, 78
 - Sinusoidal, 78
- DVI Port, 81

E

- Earth connection, 49
- EC Declaration of Conformity, 57
- Emission, 19, 78
- END key, 53
- Enter key, 52
- ENTER key, 52
- ESC key, 52
- ESD, 60
- ESD Directive, 60

F

- FCC, 59
- FM Approval, 58
- Function key
 - Labeling, 26

G

Guidelines for Explosion Protection, 58

H

HOME key, 53

I

Infotext

Key, 52

Input device

Technical specifications, 74

Instructions

General, 19

Insulation test

Test voltage, 79

interface

USB hub, **Fehler! Textmarke nicht definiert.**

Interface

24 V DC, 80

DisplayPort, 82

Rated load, 42

USB port, **Fehler! Textmarke nicht definiert.**

Interfaces

Technical specifications, 74

K

Key

ACK, 52

ALT, 52

Cancel, 52

CTRL, 52

Cursor, 53

Delete, 52, 52

END, 53

ENTER, 52

ESC, 52

HOME, 53

Scroll back, 53

Scroll forward, 53

SHIFT, 52

Switching, 52

Keys

Alphanumeric, 51

Control keys, 52

Cursor keys, 53

L

Labeling, 58, 59

EC Declaration of Conformity, 57

FM, 58

Function key, 26

Guidelines for Explosion Protection, 58

Korea, 59

UL, 58

Labeling strips

Attaching, 26

M

Marine approval, 60

Mechanical

Storage conditions, 75

Transport conditions, 75

Mounting

Horizontal mounting, 23

Notes on installation, 28

Vertical, 23

With mounting brackets, 32

With mounting clips, 31

Mounting cutout

Dimensions, 25

Preparing, 25

Mounting position, 23

N

Note

General information, 20

O

Operating system requirements, 45

KeyTools, 45

Operation

Capacitive multi-touch screen, 49

Single touch screen, 48

Touch screen, 47

P

Package contents, 21

Checking, 21

Packaging, 21

Checking, 21

Removing, 21

PE conductor, 36, 36, 49

Pixel, 20
 Defective pixel, 20

Port
 DVI port, 81

Power supply, 40, 40, 40, 80
 120V, 40
 230V, 40
 Canada, 40
 USA, 40

Protection class, 79

Protective measure
 Static electricity, 62

R

Radiation, 18
 High frequency radiation, 18

Radio interference, 19
 Emission, 78

Rated load
 Interface, 42

Regional information, 39

S

Safety
 Certificates, 57
 Standards, 57

Safety information
 Functional problem, 42
 Operation indoors, 19
 Storage, 22
 Transportation, 22
 USB port, 42

Scroll back key, 53

Scroll forward key, 53

Shift key, 52

SHIFT key, 52

Single touch screen
 Operation, 48

Standards, 57

Static electricity
 Protective measures, 62

Storage conditions, 75

Strain relief, 42

T

Technical specifications, 73

Test

For ambient conditions, 77

Touch screen
 Operation, 47
 Transport conditions, 75
 Turning off, 37

U

UL approval, 58

USA, 40

USB device
 Connecting, 41

USB hub, **Fehler! Textmarke nicht definiert.**

USB port, **Fehler! Textmarke nicht definiert.**

Use

Conditions, 76

In residential areas, 19

Industrial, 19

With additional measures, 76

W

Weight, 73

