

# SIEMENS

## SIMOREG DC-MASTER

6RA70 Series

Microprocessor-Based Converters from 6 kW to 2500 kW  
for Variable-Speed DC Drives

Application  
12-pulse Serial  
Applications



C98130-A1256-A9-1-7619

Edition 1

# SIEMENS

## SIMOREG DC-MASTER 6RA70 Series 12-pulse Serial Applications

### Legal information

#### Warning notice system

This manual contains notices you have to observe in order to ensure your personal safety, as well as to prevent damage to property. The notices referring to your personal safety are highlighted in the manual by a safety alert symbol, notices referring only to property damage have no safety alert symbol. These notices shown below are graded according to the degree of danger.

<b>▲ DANGER</b>
indicates that death or severe personal injury <b>will</b> result if proper precautions are not taken.
<b>▲ WARNING</b>
indicates that death or severe personal injury <b>may</b> result if proper precautions are not taken.
<b>▲ CAUTION</b>
with a safety alert symbol, indicates that minor personal injury can result if proper precautions are not taken.
<b>CAUTION</b>
without a safety alert symbol, indicates that property damage can result if proper precautions are not taken.
<b>NOTICE</b>
indicates that an unintended result or situation can occur if the corresponding information is not taken into account.

If more than one degree of danger is present, the warning notice representing the highest degree of danger will be used. A notice warning of injury to persons with a safety alert symbol may also include a warning relating to property damage.

#### Qualified Personnel

The product/system described in this documentation may be operated only by **personnel qualified** for the specific task in accordance with the relevant documentation for the specific task, in particular its warning notices and safety instructions. Qualified personnel are those who, based on their training and experience, are capable of identifying risks and avoiding potential hazards when working with these products/systems.

#### Proper use of Siemens products

Note the following:

<b>▲ WARNING</b>
<b>Fehler! Unbekannter Name für Dokument-Eigenschaft.</b> products may only be used for the applications described in the catalog and in the relevant technical documentation. If products and components from other manufacturers are used, these must be recommended or approved by <b>Fehler! Unbekannter Name für Dokument-Eigenschaft.</b> Proper transport, storage, installation, assembly, commissioning, operation and maintenance are required to ensure that the products operate safely and without any problems. The permissible ambient conditions must be adhered to. The information in the relevant documentation must be observed.

# 0 Contents

	Seite
<b>1</b>	<b>Instructions ..... 4</b>
<b>2</b>	<b>Applications ..... 5</b>
<b>3</b>	<b>12-puls Serienschaltung ..... 6</b>
3.1	Configuring ..... 6
3.1.1	Requirements on the device side ..... 6
3.1.2	Design of the converter transformer ..... 7
3.1.3	Voltage limits ..... 8
3.1.4	Selection of overvoltage protection ..... 10
3.1.5	Isolation monitoring ..... 11
3.2	Start-up of the SIMOREG DC-MASTER Series 6RA70 with series operation ..... 12
3.2.1	Start-up procedure ..... 12
3.2.1.1	Settings only with master ..... 12
3.2.2	Signal connection between the master and slave device ..... 12
3.2.2.1	Settings for master and slave ..... 12
3.2.3	Power increase with parallel connection ..... 14
3.2.3.1	Parallel connection of additional SIMOREG devices in 6-pulse operation ..... 14

# 1 Instructions

---

## Note

This application document does not claim to contain all details and versions of units, or to take into account all conceivable operational cases and applications.

The standard applications do not represent specific customer solutions, but are only intended to provide support in the implementation of typical applications. The operator is responsible for the correct operation of the products described.

Should you require further information or encounter specific problems which have not been handled in enough detail, please contact your local Siemens office.

The contents of this application document are not part of an earlier or existing contract, agreement or legal relationship, nor do they change such contracts, agreements or legal relationships. The contract of sale in each case outlines all the obligations of the I DT Drive Technologies Division of Siemens AG. The warranty conditions specified in the contract between the parties are the only warranty conditions accepted by the I DT Drive Technologies Division. Any statements contained herein neither create new warranties nor modify the existing warranty.

---

## WARNING

The units listed here contain dangerous electric voltages, dangerous rotating machine parts (fans) and control rotating mechanical parts (drives). Failure to follow the relevant Operating Instructions may result in death, serious injury or extensive material damage.

## Technical Support

You can also find help for technical issues through our Technical Support:

[www.siemens.de/automation/support-request](http://www.siemens.de/automation/support-request) (German)

[www.siemens.com/automation/support-request](http://www.siemens.com/automation/support-request) (English)

## **2     Applications**

SIMOREG converters of the SIMOREG DC-MASTER series are equipped with fully digital closed and open loop control and are used for armature and field supply of variable-speed DC drives.

This application documentation provides help with the configuration of the required components and start-up of the SIMOREG DC-MASTER devices in 12-pulse serial operation.

12-pulse series operation is a good option when converting from older systems to digital control (using SIMOREG DC-MASTER Control Module) with keeping the existing power section and consequently the nominal dates of the system.

Parameterization with respect to 12-pulse operation is identical for SIMOREG DC-MASTER and SIMOREG DC-MASTER Control Module, except for the specific parameters of the CM for norming the external power section.

## 3 12-puls Serienschaltung

### 3.1 Configuring

#### 3.1.1 Requirements on the device side

- ◆ Transformator

On the line side, 12-pulse operation is achieved by the addition of a winding system in the feeding transformer which is inclined by  $30^\circ$ . At least one of the two converters must be fed by an isolated voltage (isolating transformer, see figures 3.1.2a and 3.1.2b).

#### **CAUTION**

Both current converters must be supplied with a clockwise rotation field. In addition, you must ensure that the three-phase current on the slave device lags behind that of the master device by  $30^\circ$ . This phase allocation is imperative. This is to be checked by a measurement if necessary.

- ◆ Converter units

The two grid voltages of the same amount offset by  $30^\circ$  feed two SIMOREG devices with the same power on one machine, with the same current (= motor current) flowing through each power section. Each power section supplies half of the motor voltage.

The first SIMOREG unit is the master drive for closed-loop speed and current control and for the field current supply. The second SIMOREG unit is the slave drive and is connected to the master drive via paralleling interface.

The firing pulses of the slave device are  $30^\circ$  later than the firing pulses of the master device. To enable current flow with intermittent armature current, there is a firing pulse every  $30^\circ$  for both devices.

- ◆ Symmetry resistance

In 12-pulse series operation, symmetry resistances must be connected in parallel to the individual current converters connected in series, through which at least current in the amount of the maximum thyristor reverse current flows. This is the only way to ensure that, in the range of the small armature current or armature current = 0, the total armature voltage is divided symmetrically to both individual devices. Due to activation of the thyristors with long pulses, flowing of increased reversed current can result. The symmetry resistances should be dimensioned in such a way that a cross current of at least 100 mA flows at maximum armature voltage (with use of additional devices connected in parallel, also refer to Section. 3.2.3.1).

- ◆ Overvoltage protection

Converters that are connected to the network via their own converter transformer, must be protected against the overvoltages resulting from plant-side switching operations at the device input by a surge suppressor.

If the converter input is protected by open breaker gaps during primary-side switching operations of the transformer, no suppressor circuit is required on the converter input.

- ◆ Isolation monitoring

With ungrounded low-voltage networks, an insulation monitoring device must be used to monitor the state of the insulation. The insulation resistance in the ungrounded low-voltage network is monitored by continuous measurement and a signal is output if the measured value falls below a settable threshold.

### 3.1.2 Design of the converter transformer

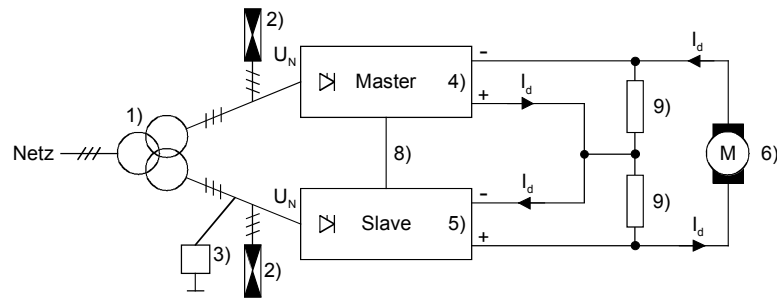

Figure 3.1.2a

#### In figure 3.1.2a:

**Transformer:** The device has its own three-winding converter transformer for connection of a higher-level voltage level to the network.

Preferred switching groups for the transformer: Dd0Dy11, Dd6Dy5, Yy0Yd11, Yy6Yd5  $u_k = 4$  to 6%

In addition, you must ensure that the three-phase current on the slave device lags behind that of the master device by  $30^\circ$ .

Type rating of transformer:  $S_T = U_N * 1,35 * 1,05 * I_d * 2$

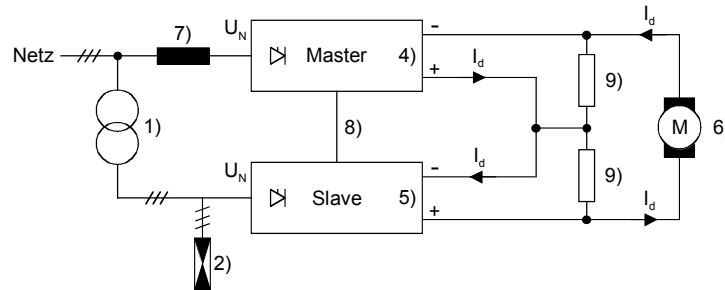

Figure 3.1.2b

#### In figure 3.1.2b:

**Transformer:** When there is a low voltage rail, an isolation transformer with a voltage transformation ratio of 1:1 is used upstream of the current converter of the slave for a  **$30^\circ$  phase shift delay**

Suitable switching groups for the transformer: Dy11, Yd11  $u_k = 4$  bis 6%

Type rating of transformer:  $S_T = U_N * 1,35 * 1,05 * I_d$

Legend for figure 3.1.2a and figure 3.1.2b:

- |                        |                           |                          |
|------------------------|---------------------------|--------------------------|
| 1) Transformer         | 2) Overvoltage protection | 3) Isolation monitoring  |
| 4) SIMOREG - Master    | 5) SIMOREG - Slave        | 6) DC-motor              |
| 7) Commutating reactor | 8) Paralleling interface  | 9) Symmetrizing resistor |

$U_N$  = Rated voltage of supplying network at converter input  
 $I_d$  = dc current through both SIMOREGs and motor

## CAUTION

If converters are connected in parallel to increase the current (parallel switching of additionally max. 5 devices per 6-pulse branch is possible), then a commutating reactor with minimum 2 %  $u_D$  must be inserted upstream of each converter for mutual decoupling of the surge suppression circuits in the paralleled converters. To ensure symmetrical current distribution between the paralleled converters, the deviation between the impedance values of the individual commutating reactors must be as low as possible. It is generally practicable to limit the deviation to 3%. The additional voltage drop across the commutating reactors must be taken into account at the planning stage.

If current converters are used, which do not have any branch fuses and 4Q operation is possible at the same time, every current converter is to be supplied with a fuse on the DC side dimensioned corresponding to its output current.

### 3.1.3 Voltage limits

Limits are set for the output voltage of a 12-pulse series system due to the isolation strength as well as the semiconductor reverse voltage of the individual devices.

Devices with 690, 830 and AC 950 V have the same gating board, i.e., the isolation against ground is designed for AC 950 V in all three devices. However, this voltage cannot be fully used, because a much higher voltage against ground can result in the system due to series connection at a ground fault. In addition, faulty function of the symmetry resistors or of one of the current converters can, e.g., result in an impermissible increase in the thyristor reverse voltages.

Therefore the input voltage of each device must not exceed the value in the following table depending on the used type of device.

Device Type MLFB	Maximum Input Voltage [ V <sub>rms</sub> ]
6RA7013-6DV62-0	298
6RA7018-6DS22-0	298
6RA7018-6DV62-0	298
6RA7018-6FS22-0	298
6RA7018-6FV62-0	298
6RA7025-6DS22-0	298
6RA7025-6DV62-0	298
6RA7025-6FS22-0	298
6RA7025-6FV62-0	298
6RA7025-6GS22-0	298
6RA7025-6GV62-0	298
6RA7028-6DS22-0	298
6RA7028-6DV62-0	298
6RA7028-6FS22-0	298
6RA7028-6FV62-0	298
6RA7031-6DS22-0	298
6RA7031-6DV62-0	298
6RA7031-6FS22-0	298
6RA7031-6FV62-0	298
6RA7031-6GS22-0	298

Device Type MLFB	Maximum Input Voltage [ V <sub>rms</sub> ]
6RA7031-6GV62-0	298
6RA7075-6DS22-0	298
6RA7075-6DV62-0	298
6RA7075-6FS22-0	298
6RA7075-6FV62-0	298
6RA7075-6GS22-0	298
6RA7075-6GV62-0	298
6RA7078-6DS22-0	207
6RA7078-6DV62-0	207
6RA7078-6FS22-0	238
6RA7078-6FV62-0	238
6RA7081-6DS22-0	207
6RA7081-6DV62-0	207
6RA7081-6GS22-0	298
6RA7081-6GV62-0	298
6RA7082-6FS22-0	298
6RA7082-6FV62-0	298
6RA7085-6DS22-0	298
6RA7085-6DV62-0	298
6RA7085-6FS22-0	298



Device Type MLFB	Maximum Input Voltage [ V <sub>rms</sub> ]
6RA7085-6FV62-0	298
6RA7085-6GS22-0	298
6RA7085-6GV62-0	298
6RA7086-6KS22-0	358
6RA7086-6KV62-0	358
6RA7087-6DS22-0	298
6RA7087-6DV62-0	298
6RA7087-6FS22-0	298
6RA7087-6FV62-0	298
6RA7087-6GS22-0	298
6RA7087-6GV62-0	298
6RA7088-6LS22-0	430
6RA7088-6LV62-0	430
6RA7090-6GS22-0	298
6RA7090-6GV62-0	298
6RA7088-6KS22-0	358
6RA7090-6KV62-0	358
6RA7091-6DS22-0	298
6RA7091-6DV62-0	298
6RA7091-6FS22-0	298
6RA7091-6FV62-0	298
6RA7093-4DS22-0	298
6RA7093-4DV62-0	298
6RA7093-4GS22-0	298
6RA7093-4GV62-0	298
6RA7093-4KS22-0	430
6RA7093-4KV62-0	430
6RA7093-4LS22-0	430
6RA7093-4LV62-0	430

Device Type MLFB	Maximum Input Voltage [ V <sub>rms</sub> ]
6RA7095-4DS22-0	298
6RA7095-4DV62-0	298
6RA7095-4GS22-0	298
6RA7095-4GV62-0	298
6RA7095-4KS22-0	430
6RA7095-4KV62-0	430
6RA7095-4LS22-0	430
6RA7095-4LV62-0	430
6RA7096-4GS22-0	298
6RA7096-4GV62-0	298
6RA7096-4MS22-0	492
6RA7096-4MV62-0	492
6RA7097-4GS22-0	298
6RA7097-4GV62-0	298
6RA7097-4KS22-0	492
6RA7097-4KV62-0	492
6RA7098-4DS22-0	298
6RA7098-4DV62-0	298
6RA7093-4GS22-6	298
6RA7093-4LS22-6	492
6RA7095-4GS22-6	298
6RA7095-4KS22-6	492
6RA7095-4LS22-6	492
6RA7096-4GS22-6	298
6RA7096-4MS22-6	492
6RA7097-4GS22-6	298
6RA7097-4KS22-6	492
6RA7095-4GS22-7	298
6RA7096-4GS22-7	298

If higher input voltages are present, the use of SIMOREG DC-MASTER Control Module devices in connection with correspondingly suitable external power sections is a good option to achieve the required voltage insulation strength. According systems are offered on request.

### 3.1.4 Selection of overvoltage protection

The overvoltage protection is used to protect the semiconductor rectifiers of converters from overvoltages between the phases of a three-phase system. The limiting voltage of the overvoltage protection must not be any higher than the reverse voltage of the rectifiers to be protected.

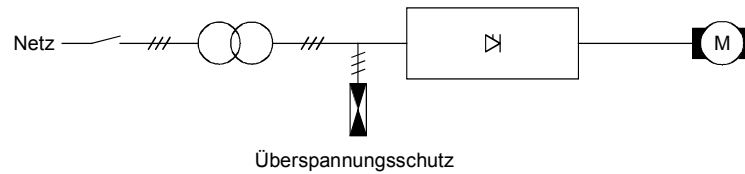

Figure 3.1.4

The transformer is connected on the line side as shown in Fig. 3.1.4. If the transformer is switched off during load operation, the arc of the primary-side switch does not completely relieve the magnetizing energy of the transformer. When firing pulses are prohibited this energy causes overvoltage at the secondary side of the transformer. In that case, an overvoltage protection must absorb the magnetization energy of the transformer and limit the voltage.

At switching off under no-load condition, the overvoltage protection must only handle the magnetizing energy of the transformer. The magnetization energy is calculated as follows:

$$W_M = \frac{S_N}{4 \cdot \pi \cdot f} \cdot \frac{I_0}{I_N}$$

$W_M$  = Magnetization energy of transformer

$S_N$  = Rated power of transformer

$I_0$  = No-load current of transformer

$I_N$  = Rated current of transformer

$f$  = Line frequency in Hz

At shutdown in the case of a malfunction, the shunted energy is greater corresponding to the load, wherein motor and generator load must be distinguished.

A "SICROWBAR 7VV3002 AC overvoltage protection unit for thyristors and diodes" is available for connection between the three line phases to provide overvoltage protection.

Information about calculating the energy to be shunted in the various operation cases and specifications for SICROWBAR 7VV3002 is available in

Betriebsanleitung/Operating Instructions 11.2007  
SICROWBAR 7VV3002  
C98130-A7200-A1-4-7419

Link to the operating instruction

<http://support.automation.siemens.com/WW/view/en/17635427/133300>

Recommended dimensioning for 10000 switching cycles.

### 3.1.5 Isolation monitoring

In ungrounded low voltage networks a ground-leakage monitor is used to monitor the insulation resistance. This measures the current that flows across a known series resistor. For this purpose, a measuring voltage is injected into the network against the PE conductor. If the measured value falls below the settable threshold value for the insulation resistance, an alarm is output.

As the network on the DC voltage side is not isolated because of the parallel connection of the two converter sections, only one ground-leakage monitor can be used to monitor the line and DC voltage side for a ground fault.

Possible devices that can be used for insulation monitoring:

Rated voltage network	Type	Manufacturer
up to 690 V	MR627	AREVA T&D / ALSTOM
	IRDH 275 / IRDH375	BENDER
up to 1000 V	MR627 mit MZ611	AREVA T&D / ALSTOM
	IRDH 275 / IRDH375 mit AGH 150W-4	BENDER
up to 1300 V	IRDH 275 / IRDH375 with AGH 204S-4	BENDER

Due to characteristics of the system the power section of the converter is connected to ground with high-resistance (measurement of ac and dc voltage by high-resistant differential amplifiers for synchronization, monitoring, measurement of armature voltage and EMF). This leakage resistance has to be considered when setting the warning and cut-out levels of the isolation monitor. The following table shows the leakage resistance against rated supply voltage per device. The total resistance for a parallel configuration has to be calculated in consideration of the parallel connection of each individual leakage resistance.

Measurement of armature circuit	
Rated supply voltage	Leakage resistance
Low voltage device (85 V)	134 kΩ
up to 575 V (400 V, 460 V, 575 V)	908 kΩ
up to 830 V (690 V, 830 V)	1308 kΩ
up to 1000 V (950 V)	1576 kΩ
Measurement of field circuit	
Low voltage device (130 V)	510 kΩ
all other devices	1815 kΩ

## 3.2 Start-up of the SIMOREG DC-MASTER Series 6RA70 with series operation

### 3.2.1 Start-up procedure

#### 3.2.1.1 Settings only with master

- ◆ Perform start-up according to Chapter 7.5 of the operating instructions until Point 7.3.
- ◆ Separate the slave device from external power supply for the time of the optimization run for current control and precontrol and short-circuit it on the output side.

#### CAUTION

Make sure that the cross-section of the shorting bar is sufficiently dimensioned, since up to 120% motor rated current can temporarily flow during the current controller optimization run and the resistance of the armature circuit is determined in addition.

- ◆ On the master **and** slave device, set **U800 = 0**.
- ◆ Carry out optimization run by means of **P051 = 25** and ON command

The total armature circuit values **P110** and **P111** as well as  $T_N$  armature **P156** are set correctly.  
The automatically determined current controller P gain **P155** must be set manually to half the value!

- ◆ Set correction of the zero crossings: **P826.01....P826.06 = 0**.

### 3.2.2 Signal connection between the master and slave device

Signal exchange is carried out exclusively via the paralleling interface X165/X166. Therefore, both devices must be equipped with the CUD2 additional module.

The master device takes over the complete control and generates the trigger pulses for all devices.

#### 3.2.2.1 Settings for master and slave

- ◆ Remove the shorting bar on the slave, restore the mains connections.
- ◆ Assign the following parameters:

12-Puls-Serien-Master		12-Puls-Serien-Slave	
<b>U800 = 1</b>	Select paralleling interface The gating pulses are generated by this SIMOREG converter	<b>U800 = 2</b>	Select paralleling interface The gating pulses of the master are used
<b>U803 = 0</b>	Standard mode		
<b>U804.01 = 30</b>	1st. transmit data: Control word 1	<b>U804.01 = 32</b>	1st transmit data: Status word 1
<b>U804.02 = 31</b>	2nd transmit data: Control word 2		
<b>U804.03 = 167</b>	3rd transmit data: Actual speed value		
<b>U805 = 1</b>	(bus terminator) at the two outermost devices (at the physical ends of the bus line)		
<b>U806.01 = 12</b>	Master device for 1 slave device	<b>U806.01 = 2</b>	1 Slave

<b>U806.02</b> set the same as U806.01	<b>U806.02</b> set the same as U806.01
<b>P082</b> <=> <b>0</b> Operating mode for field	<b>P082 = 0</b> Internal field not used
<b>P083</b> set according to the source of the actual speed value	<b>P083 = 4</b> Actual speed value selected by P609 <b>P609 = 6023</b> Actual speed value from master is used (3rd process data word)
<b>P100 =</b> Rated motor armature current If several devices are connected in parallel, the set value must be divided by the number of devices.	<b>P100 =</b> Rated motor armature current If several devices are connected in parallel, the set value must be divided by the number of devices.
<b>P648, P649</b> set according to the source of the control word	<b>P648 = 6021</b> Control word 1 from master is used (1st process data word) <b>P649 = 6022</b> Control word 2 from master is used (2nd process data word)
	<b>P820.07 = 42</b> Fault message F042 is deactivated
	<b>P821.01 = 31</b> Warning message A031 is deactivated
<b>P079 = 2</b> Long pulses are output every 30° for 12-pulse serial application If several devices are connected in parallel, <b>P079 = 3</b> must be set for the devices connected in parallel to the master.	<b>P079 = 2</b> Long pulses every 30° for 12-pulse serial application
<b>P101 =</b> Rated motor armature voltage / 2	
<b>P110 =</b> Armature circuit resistance <b>P111 =</b> Armature circuit inductance The optimization run for current controller and pre-control (P051 = 25) sets P110 and P111 correctly when the slave is jumpered.	<b>P110 =</b> same setting to be made as at master <b>P111 =</b> same setting to be made as at master
<b>P155 =</b> Value of optimization run / 2	
<b>P162 = 0</b> EMF value from the internal measured armature voltage is applied	
<b>P163 = 4 oder 5</b> 20 or 40 ms PT1-filtering of EMF for armature pre-control	
<b>P826.01 bis 06 = 0</b> Correction of natural commutation timing	

- ◆ Carry out optimization runs for speed controller, field weakening by means of **P051 = 26, 27** and ON command  
Those optimization runs are carried out already in real 12-pulse mode.

#### Special features for controlling the devices:

It is recommended to evaluate the fault message of the slave drive and to shut down the master too in the case of a slave malfunction. For example, this can be done by opening terminal 37 on the master or by using the fault bit of the slave (status word1.Bit3, inverted) as OFF2 command of the master or as source of an external fault (bit-by-bit specification of the control word bits on the master by means of P648=9 and P655=6223 on the master for the fault bit from slave 2).

#### Notes:

If two devices are connected in series, the two devices always carry exactly the same current. This current can be monitored in the master at terminals 12/13 (actual current value output on the CUD1) and in Trace 2 of the DriveMonitor. Depending on the system, the actual current value in the slave is not correct and therefore cannot be used for diagnostic purposes.

Only if the armature voltage is symmetrically distributed between the two (groups of) devices, the EMF, internally calculated from the armature voltage measured (at the master) by subtracting half of the ohmic and inductive armature voltage drop, can be used as input value for the armature current precontrol (P162=0) and as actual value for the EMF control (P616=286).

If the armature current is not intermittent, each of the two (groups of) devices supplies the same partial armature voltage only in case of temporally equidistant thyristor firing. Only then does the calculated partial EMF value averaged over a complete "6-pulse firing cycle" of the 12-pulse series master correspond to half the total EMF of the motor. Since this is not the case if the control angle varies, it is recommended, with regard to a smooth armature current for armature current precontrol, to set a slightly stronger EMF smoothing (e.g. P163=4 or 5).

### 3.2.3 Power increase with parallel connection

Additional SIMOREG units can be connected to increase power.

#### 3.2.3.1 Parallel connection of additional SIMOREG devices in 6-pulse operation

It is possible to connect additional devices parallel to the 12-pulse series master device and the 12-pulse series slave device to increase output current. A maximum of 6 SIMOREG devices are possible, i.e., 2 groups in a series composed each of 3 devices connected in parallel. The paralleling interface serves for coupling. With software version 2.10 and above, **P079 = 3** is available for parameter setting, which needs only be set on the device(s) that is(are) connected in parallel to the 12-pulse master device(s) (long pulses every 30° for parallel switch device of the 12-pulse series master with 12-pulse series operation).

Parameterization of the devices is also based on Chapter 6.3.2.1 of the 6RA70 Operating Instructions (parallel connection, default operating mode). A SIMOREG device of each group of devices connected in parallel is the master of this group; the others are slaves.

Wiring proposal



Abbildung 3.2.3.1

Legend for figure 3.2.3.1:

- |                        |                           |                          |
|------------------------|---------------------------|--------------------------|
| 1) Transformer         | 2) Overvoltage protection | 3) Isolation monitoring  |
| 4) SIMOREG - Master    | 5) SIMOREG - Slave        | 6) DC-motor              |
| 7) Commutating reactor | 8) Paralleling interface  | 9) Symmetrizing resistor |

$U_N$  = Rated voltage of supplying network at converter input

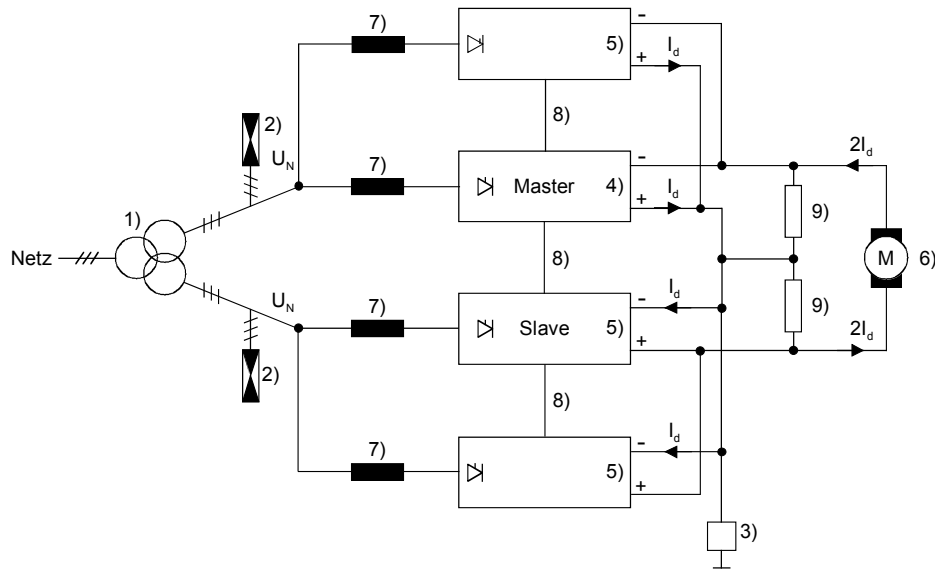
$I_d$  = dc current through SIMOREG and motor

Parameter settings of the devices in 6-pulse operation

Parameter	
P078.01 =	Voltage of a transformer coil for the power section
P100 =	Motor current divided by the number of SIMOREG devices connected in parallel
P102 =	Rated motor voltage / 2
P826.01 bis P826.6 = 0	Correction of natural commutation timing

Remark:

Only the 12-pulse series master device generates firing pulses (**U800 = 1**). All other devices use the firing pulses of the master device (**U800 = 2**). A device connected in parallel to the 12-pulse series master device must switch thyristor numbers and torque direction at the same time with the 12-pulse series master device (**P079=3**); on the other hand, the 12-pulse series device and devices (**U800 = 2**) connected in parallel to this device are delayed by 30 degrees (**P079=2** causes this delay).

F030 overvoltage evaluation:

Set U580=4 at master and slaves.

With parallel connection of devices, the symmetry resistors are to be dimensioned differently.

With parallel connection of a device, the cross current at maximum voltage should be at least 200 mA and for two devices at least 300 mA.

When devices are operated in parallel, it makes sense to set additional alpha-W pulses (P161, P179) or a torque-free pause (P160) depending on the value of the effective inductances, because current can still flow in spite of the I=0 message to the master.

Perform all optimization runs with the total arrangement.

Example for the settings of a 12-pulse series system of 2 groups with 3 devices in 6-pulse mode each:

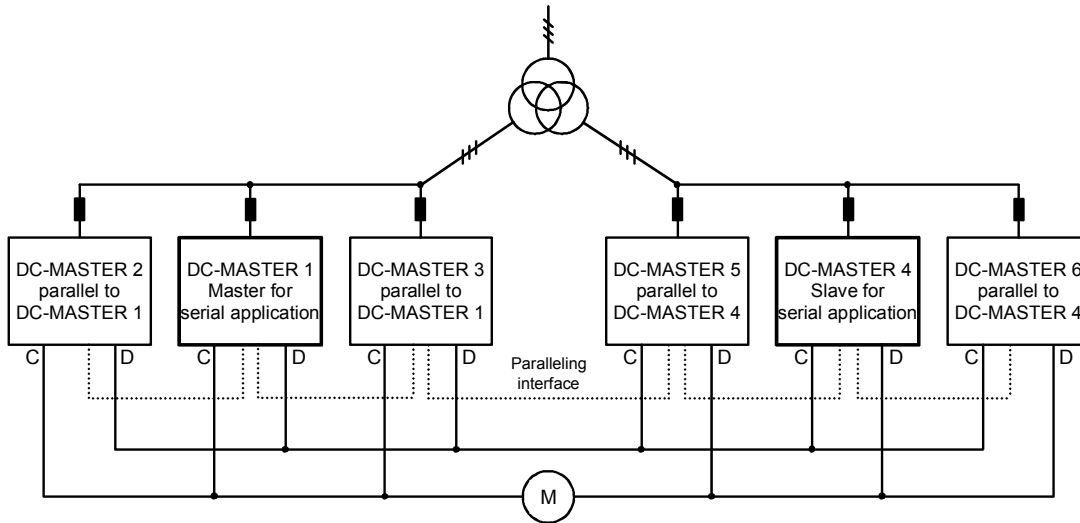

	DC-MASTER 2	DC-MASTER 1 (12-Puls master)	DC-MASTER 3		DC-MASTER 5	DC-MASTER 4 (12-Puls slave)	DC-MASTER 6
P082	0	according to application	0		0	0	0
P083	4	according to source	4		4	4	4
P609	6023	-	6023		6023	6023	6023
P100	*)	$I_{rated,motor} / 3$	*)		*)	*)	*)
P101	*)	$U_{rated,armat.} / 2$	*)		*)	*)	*)
P110	*)	actual armat. resist.	*)		*)	*)	*)
P111	*)		*)		*)	*)	*)
P155 = value according to optimization run / 2							
P162 = 0 EMF for armature precontrol is determined of internal measured armature voltage							
P163 = 4 oder 5 20 or 40ms PT1 filtering of EMF for armature precontrol							
P826.01 to P826.06 = 0 correction of natural commutation timing							
P648	6021	according to source	6021		6021	6021	6021
P649	6022	according to source	6022		6022	6022	6022
P079	3	2	3		2	2	2
U800	2	1	2		2	2	2
U803	0	0	0		0	0	0
U804.01	32	30	32		32	32	32
U804.02	**) )	31	**) )		**) )	**) )	**) )
U804.03	**) )	167	**) )		**) )	**) )	**) )
U804.04	**) )	**) )	**) )		**) )	**) )	**) )
- U804.05							
U805	1	0	0		0	0	1
U806.01	2	16	3		5	4	6
U806.02	2	16	3		5	4	6

\*) same as for master 1    \*\*) optional



---

### **Trademarks**

All names identified by ® are registered trademarks of the Siemens AG. The remaining trademarks in this publication may be trademarks whose use by third parties for their own purposes could violate the rights of the owner.

### **Disclaimer of Liability**

We have reviewed the contents of this publication to ensure consistency with the hardware and software described. Since variance cannot be precluded entirely, we cannot guarantee full consistency. However, the information in this publication is reviewed regularly and any necessary corrections are included in subsequent editions.

Siemens AG  
Industry Sector  
Postfach 48 48  
90026 NÜRNBERG