



SPECIFICATIONS

TITLE : 320x240 MONO STN DISPLAY

NUMBER : HLM8619-010300 REV.A PAGE 1

HOSIDEN CORPORATION

HLM 8619 - 010300 - HIGH GRADE

**PASSIVE MONOCHROME
HIGH GRADE LCD DISPLAY**

TRANSFLECTIVE TYPE

320 x 240 DOTS

CONTENTS

1. FEATURES
2. ABSOLUTE MAXIMUM RATINGS
3. MECHANICAL CHARACTERISTICS
4. OPTICAL CHARACTERISTICS
5. ELECTRICAL CHARACTERISTICS
6. INTERFACE CONNECTOR
7. BLOCK DIAGRAM
8. INTERFACE TIMING
9. CCFL BACKLIGHT UNIT
10. RELIABILITY
11. LOT NUMBER MARKING
12. HANDLING PRECAUTION
13. TERMS OF WARRANTY
14. DRAWING

1. FEATURES

Display Format	320 x 240 Dots (Graphic Type)
Display Mode	STN Positive transfective type, F-STN Mode with CFL Backlight
Screen Area	121 x 91,6 mm
Contrast Ratio	12:1 (typ.)
Driving Method	1/240 duty
Power Supply	+5V (VCC) / -23V (VEE)
Interface	5V CMOS Level
Backlight	CFL edgelight system

2. ABSOLUTE MAXIMUM RATINGS

Item	Symbol	Value	Unit	Remark
Supply Voltage (Logic)	V _{DD} -V _{SS}	6 max.	V	
Supply Voltage	V _{DD} -V _{EE}	30 max.	V	
Input Voltage	V _{in}	V _{SS} ≤ V _{IN} ≤ V _{DD}	V	
Storage Temperature	T _{stg}	-20 ... 60	°C	
Operating Temperature	Top	0 ... 50	°C	
Extended Operating Temperature	Top	-5 ... 55	°C	Note 1

Note 1 : Maximum temperature range with reduced optical parameters

3. MECHANICAL CHARACTERISTICS

Item	Standard Value	Unit	Remark
Module Size	157,8 x 121,6 x 11,5	mm	Except FFC Cable
Viewing Area	121 x 91,6	mm	
Active Area	115,17 x 86,37	mm	
Dot Size	0,33 x 0,33	mm	
Dot Pitch	0,36 x 0,36	mm	
Weight	230 (typ.)	grams	

4. OPTICAL CHARACTERISTICS

Item	Symbol	Condition	Min	Typ	Max	Unit	Remark
Response Time	Rise	$T_a=25^{\circ}\text{C}$ $\theta=0^{\circ}, \phi=0^{\circ}$	-	140	250	ms	Note 1
	Fall		-	270	400	ms	Note3
Contrast Ratio	CR	$T_a=25^{\circ}\text{C}, \theta=0^{\circ}, \phi=0^{\circ}$	8	12	-		Note2
Viewing Angle	$\theta_1 + \theta_2$	$T_a=25^{\circ}\text{C}, \phi=0^{\circ}, \text{CR} \geq 1,4$	45	-	-	deg	Note 3
Frame Frequency			65	70	75	Hz	
Viewing Direction				6:00		o'clock	

NOTE 1 : Definition of optical response time

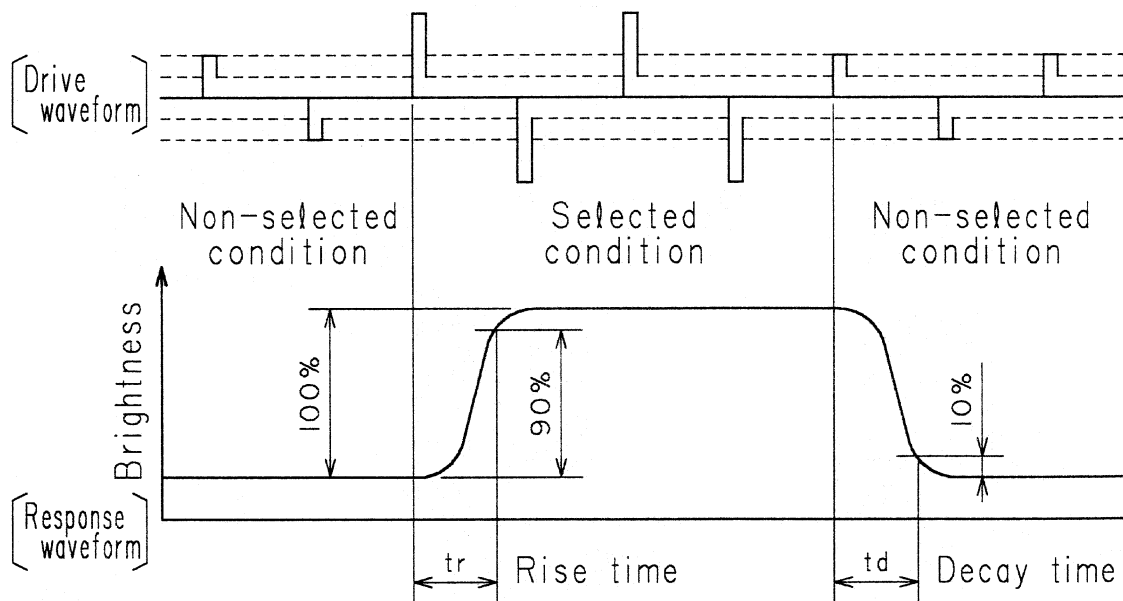

Note 2 : Definition of contrast ratio C_R

$$C_R = \frac{\text{Brightness in selected segment}(B1)}{\text{Brightness in non-selected segment}(B2)}$$

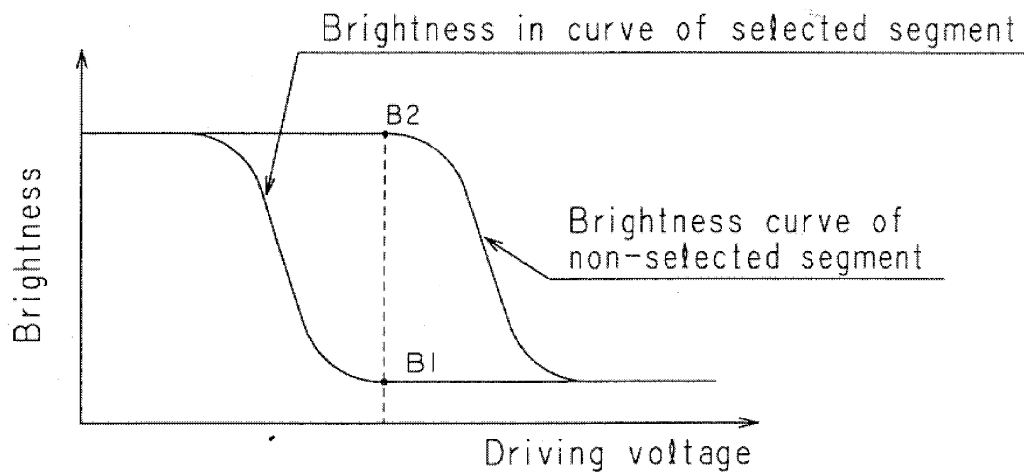

Note 3 : Viewing direction θ and ϕ

θ : Angle of between observed position and Normal. ($0^\circ \leq \theta \leq 90^\circ$)

ϕ : Angle of between observed position and Y axis. ($0^\circ \leq \phi \leq 360^\circ$)

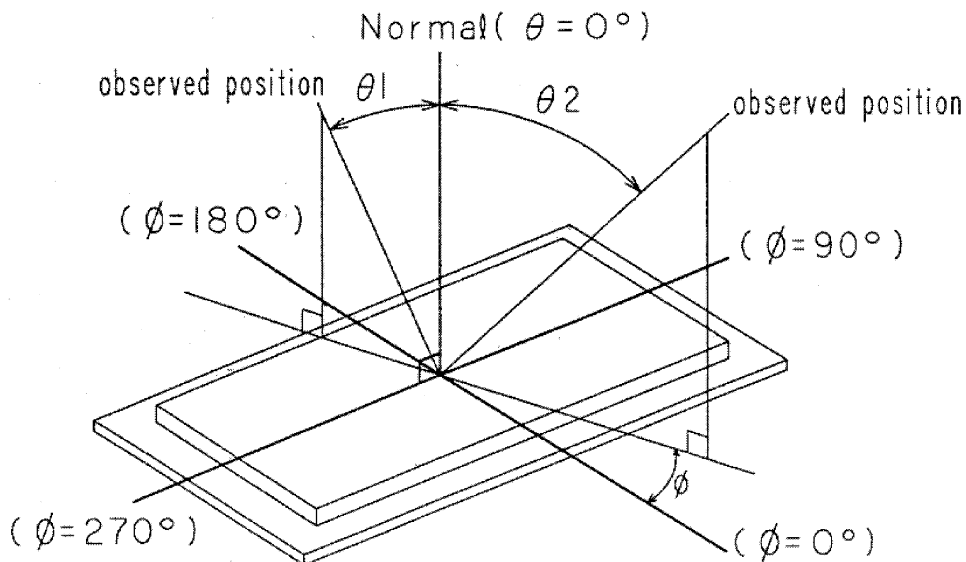

5. ELECTRICAL CHARACTERISTICS (LCD)

Item	Symbol	Condition	Min	Typ	Max	Unit
Supply Voltage (Logic)	V _{DD}	V _{DD} ± 10%	4,5	5	5,5	V
Supply Voltage (LCD)	V _{DD-V_O}	θ=0°, φ=0° Ta=0°C	-	24,4	-	V
		θ=0°, φ=0° Ta=25°C	-	23,7	-	V
		θ=0°, φ=0° Ta=50°C	-	23	-	V
Supply current (Logic)	I _{DD}	V _{DD} =5V, V _O =-18,3V		3,8	12	mA
Supply Current (LCD)	I _{EE}	Frame Signal = 70Hz	-	2,4	10	mA

6. INTERFACE CABLE

1 mm pitch FFC Cable is fixed on the display.

Suitable Interface to standard 2,54 connector : IF155 (Data Display)

Suitable connectors for through hole (90/180°) or surface mount (90°)

are available on request

Pin No.	Signal Name	Function
1	V _O	Control for LCD drive voltage
2	V _{EE}	Power supply voltage for LCD drive
3	D3	Display Data 3
4	D2	Display Data 2
5	D1	Display Data 1
6	D0	Display Data 0
7	M	LCD drive signal (AC signal) *1
8	V _{SS}	Ground
9	V _{DD}	+5V Logic Supply Voltage
10	CP2	Display Data Shift Clock
11	CP1	Display Data Latch Clock
12	S	Frame Signal (Sync. of display)
13	DISP OFF	Display ON (H) / OFF (L)
14	F.G.	Frame Ground

*1 Note : M is generated on board or supplied externally (see block diagram)
 Default setting is internal generation (no external signal necessary)

7. BLOCK DIAGRAM

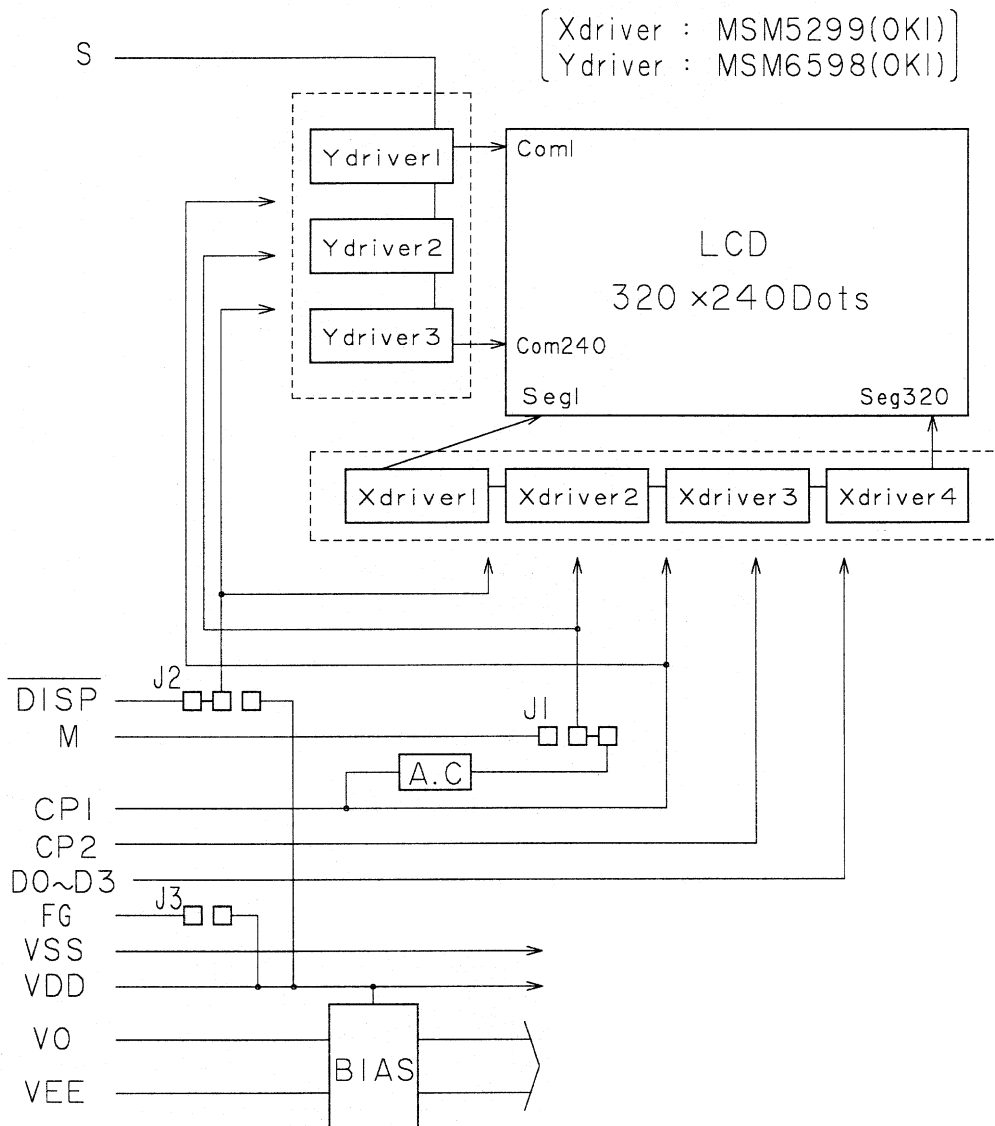

- A.C. : M-signal generation circuit
M-signal may be optionally supplied externally (change J1 setting)
- BIAS : BIAS voltage generation circuit

To avoid latch-up effects the power on/off sequencing should be as following :

ON : Logic voltage (VDD) should be applied before or at same time with LCD voltage (VEE)

OFF : LCD voltage (VEE) should be removed before or at the same time as Logic voltage (VDD)

8. INTERFACE TIMING

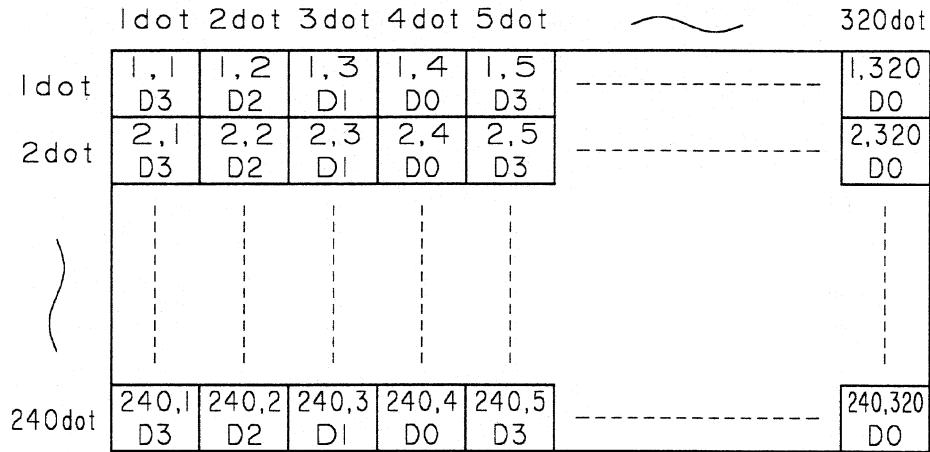

(DATA MAP)

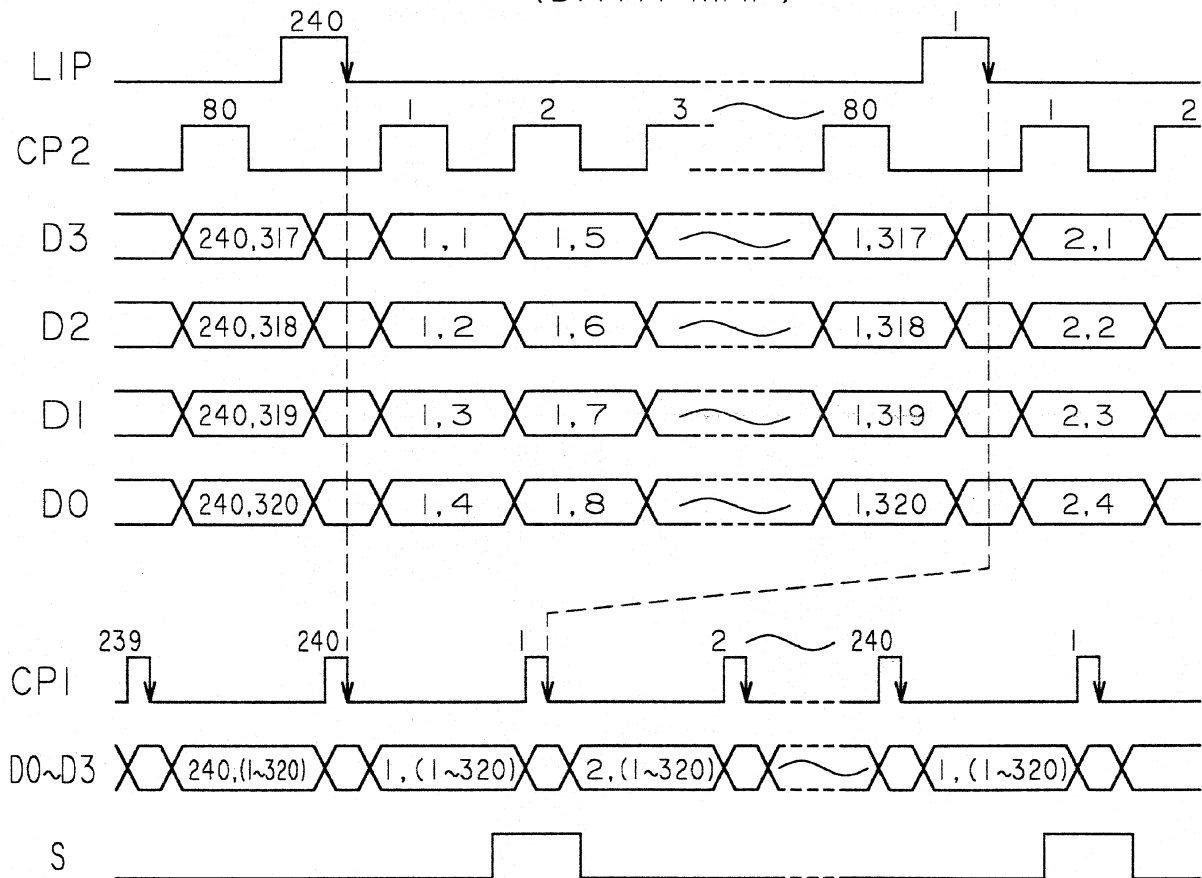

8-1 TIMING CHART

	Symbol	Condition	Min	Typ	Max	Unit
CLP Frequency	f _{CP}	Duty=50%	3.4	-	-	MHz
CLP Pulse Width	t _{cw}	-	100	-	-	ns
CLP Rise / Fall Time	t _r ,t _f	-	-	-	50	ns
Data Setup Time	t _{DSU}	-	50	-	-	ns
Data Hold Time	t _{DHD}	-	80	-	-	ns
CLP Setup Time	t _{ESUI}	-	90	-	-	ns
LIP -> CLP Time	t _{LC}	-	200	-	-	ns
LIP Pulse Width	t _{lw}	-	100	-	-	ns
FRP Setup Time	t _{fsu}	-	100	-	-	ns
FRP Hold Time	t _{fhd}	-	100	-	-	ns

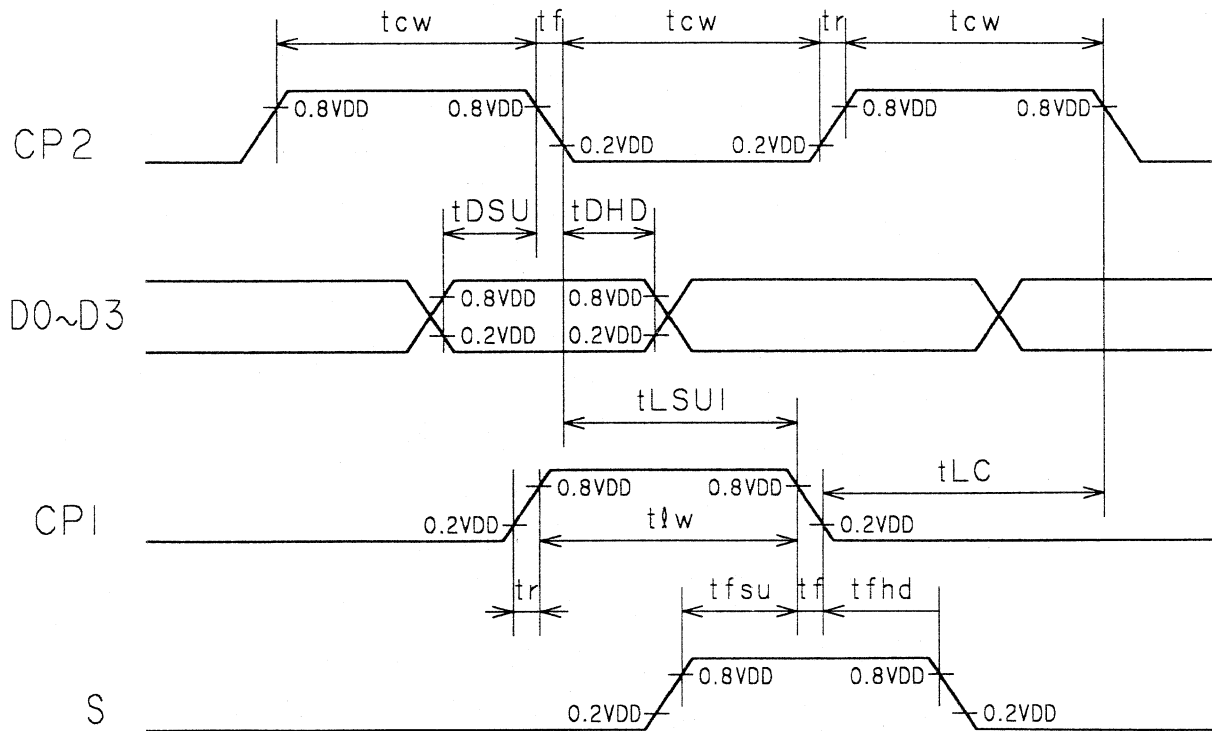

9. CFL UNIT

9-1 CCFL Lamp

Item	Symbol	Value	Unit
Discharging Tube current	(IL)	5	mA
Discharging Tube voltage	(VL)	295	Vrms
Starting Tube Voltage	(VS)	1050	Vrms
Brightness (Tube)	(B)	33.000	Nit
Tube diameter	Ø	3	mm
Tube length	l	86	mm
Half Brightness Time	min	18.000	h
Half Brightness Time	typ	23.000	h

The definition of half brightness time is average brightness decreased to 50% of initial average brightness value (@ 5mA, 25°C).

9-2 Example of Inverter

Inverter : TDK TAD170 (5V) or 8m8619 (5Vor 12V)
 Input current : 0,2A
 Output current : 5,0 mArms
 Drive frequency : 30 kHz (typ)

9-3 Interface connector

Used connector : IL-G-4S-S3C2 (*1)
 Manufacturer : JAE

Pin No.	Signal Name	Function
1	HV	High Voltage
2	NC	Not connected
3	NC	Not connected
4	GND	Ground

*1 Suitable through hole connectors (90°/180°) are available on request.

10. UNIFORMITY CHARACTERISTICS

10-1 Standard Value

Non-uniformity = | Max. Value - Mean Value) / Mean Value | * 100 ≤ 30%

Non-uniformity = | Min. Value - Mean Value) / Mean Value | * 100 ≤ 30%

Max. Value : Maximum Contrast

Mean Value : Mean Contrast

Min. Value : Minimum Contrast

| : Absolute Value

10-2 Measurement conditions

Contrast is measured at 9 locations and the mean contrast is calculated. (Point A ... I)

CCFL Backlight power-on time : 10 minutes

Discharging Tube Current (IL) : 5 mA

Temperature : 25°C

VDD - VO : 23.3 V

Measurement diameter : 8 mm

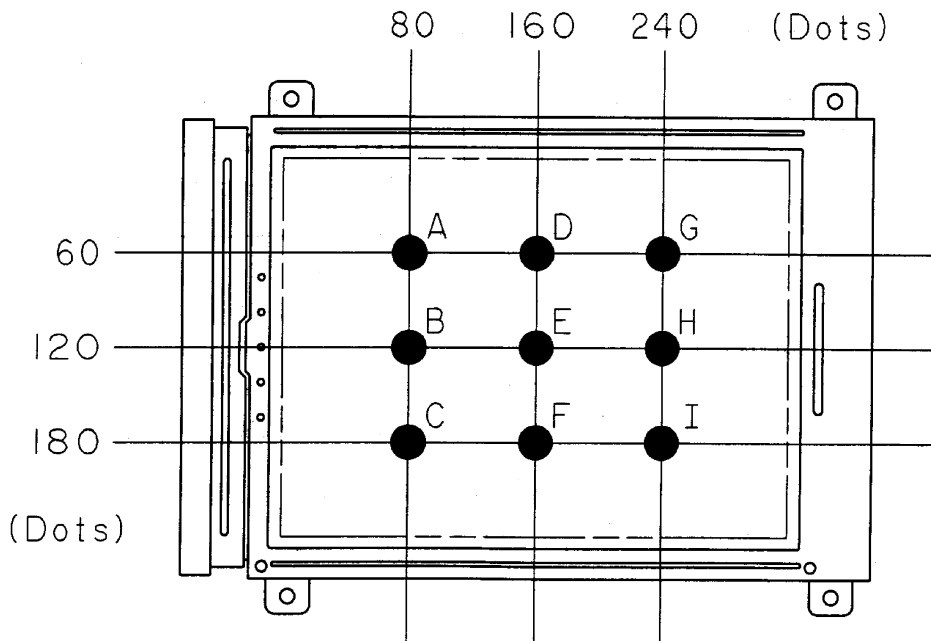

10. RELIABILITY

Item	Condition
High temperature storage	60°C 120h
Low temperature storage	-20°C 120h
Damp heat storage	40°C / 90% RH 120h
Thermal cycles	5 cycles see below diagram
Vibration	Total amplitude : 1,5 mm Frequency : 10 .. 55 .. 10 Hz Tested at above condition for X,Y,Z directions 60 min. each

Temperature Cycle Diagram

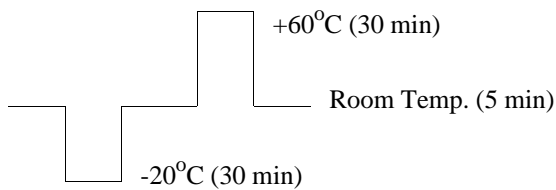

10-1 Evaluation Criteria

Every test item should meet the following criteria :

- All of the segments (dots) should be not blurred
- All segments (dots) should be usually displayed

Judgements should be made after exposure in room temperature condition for 4 hours.

11. LOT MARKING

The manufacturing lot number is marked on each module

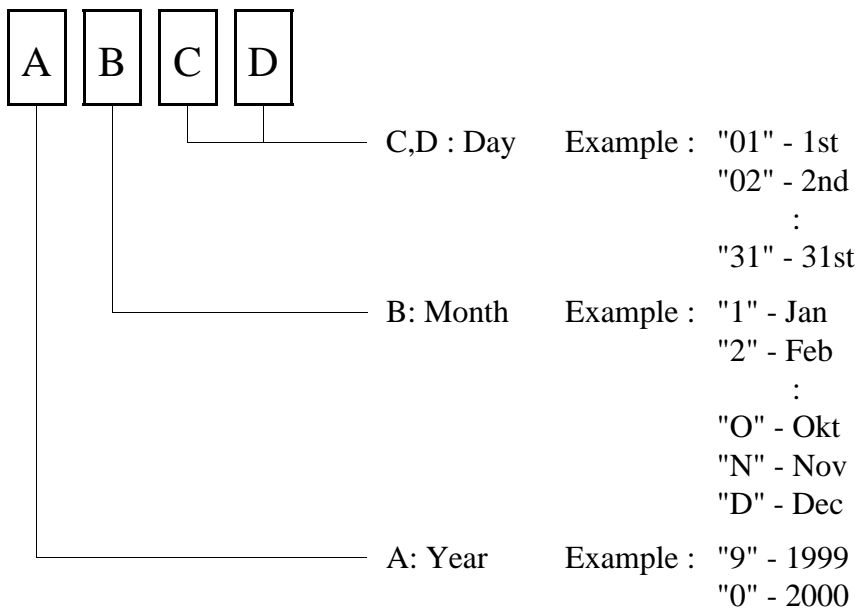

12. HANDLING PRECAUTION

1. Do not disassemble the module
2. Since the LCD cell is made of glass, do not apply strong mechanical impact or static load onto it. Handle with care, and do not twist or bend the LCD module.
3. In case the LCD cell is broken, do not sip or drink leaked liquid crystal material. If the liquid crystal material touched your skin, wash it out with soap immediately.
4. Store and use within ratings in order to keep performance and prevent damage.
5. Do not drop water or any chemicals onto the display surface.
6. Handle the polarizers with care as it maybe easily scratched. Do not press or rub them with any hard object.
7. Do not apply high electrostatic voltage to the LCD module. It may damage CMOS / LSI circuit in the LCD module. Ground yourself when you touch the LCD module directly.
8. When you handle the LCD module for incoming inspection or assembly, use soft fingerstalls or gloves in order to keep the display quality.
9. Do not pull or fold the CCFL cable

13. TERMS OF WARRANTY

13-1 Incoming Inspection

Incoming inspection by the customer shall be performed within thirty (30) days from the shipping date.

13-2 Warranty Period

HOSIDEN warrants the LCD modules for a period of 6 months from the shipping date when stored or used under normal conditions.

14. DRAWING

See following page.

If a more detailed drawing is necessary please contact HOSIDEN or its representatives.

TITLE : 320x240 MONO STN DISPLAY

NUMBER : HLM8619-010300 REV.A PAGE 14

