

---

# **S83/85 Ultrasonic Generator**

## **A40-064**



---

# 1 Introduction

## 1.1 Manual Change Information

At Branson, we strive to maintain our position as the leader in ultrasonic cleaning and related technologies by continually improving circuits and components in our equipment. These improvements are incorporated as soon as they are developed and thoroughly tested.

Information concerning any improvements will be added to the appropriate manual section(s) at the next printing. Therefore, when requesting service assistance for specific units, refer to the revision level of this manual.

---

## 1.2 Warranty

### 1.2.1 Equipment

When used in accordance with written instructions and under normal operating conditions, Branson manufactured products are guaranteed to be free from defects in material and workmanship for ONE YEAR. In addition, Branson Series 8000 Power Supplies are guaranteed for TWO YEARS. Transducer elements and their bond are guaranteed for the LIFETIME of the radiating surface when used in accordance with manufacturer's instructions. All guarantees are from the date of invoice.

This warranty *shall not* apply to the following:

- Cavitation erosion of tank or immersible transducer surfaces, which is process related and a normal occurrence in the operation of an ultrasonic cleaning system.
- Equipment subjected to misuse, improper installation, alteration, neglect, or accident.

Any equipment which proves defective during the stated period will be repaired or replaced at the sole discretion of Branson, F.O.B. Danbury, CT, or other repair depot as specified by Branson.

### 1.2.2 Process

Branson will guarantee any process developed in their applications laboratory for ninety days following the installation of recommended Branson equipment when the following stipulations are met:

- The customer must supply a sufficient quantity of parts with soils representative of the parts to be cleaned in production.
- A sample of those parts will be labeled and sealed.
- The balance of the customer-supplied parts will be cleaned using a process developed and recommended by Branson.
- Cleanliness levels will be determined by a methodology agreed upon by Branson and its customer.
- A sample of the cleaned parts will be labeled and sealed as representative of the recommended process.

Branson guarantees, in accordance with the above, that parts received into the Branson precision cleaning system with the same level and condition of soil as the laboratory and subjected to the recommended process will be cleaned to the same level as that demonstrated in the laboratory.

Should the equipment or process fail to meet the agreed upon level of cleanliness, Branson will be afforded a reasonable time to remedy the problem. Following that period, the customer will have the right to return the equipment in accordance with normal return policies.

### 1.2.3 Limitations of Liability

Branson's liability, whether based on warranty, negligence, or other cause, shall not in any case exceed the cost of the equipment. In no case shall Branson be responsible for any consequential damages arising out of commercial loss.

This warranty is limited to the original purchaser and is not transferable. No warranties expressed or implied have been made other than those stated herein. SELLER DISCLAIMS ANY WARRANTY OF MERCHANTABILITY OR WARRANTY OF FITNESS FOR A PARTICULAR PURPOSE.

---

### 1.3 Warnings

**Warning:** *Ultrasonic Power supplies produce high voltage. Before working on an ultrasonic power supply, do the following (1) turn off the ultrasonic power supply and unplug AC voltage; and (2) remove the cover and allow at least 1 minute for capacitors to discharge.*

**Warning:** *Transducer (elements) can hold a high voltage charge. Before troubleshooting or making repairs, discharge voltage by momentarily shorting pins A and B of the RF connector that plugs into the ultrasonic power supply.*

---

## 1.4 Table of Contents

S83/85 Ultrasonic Generator .....	1
1 Introduction .....	3
1.1 Manual Change Information .....	3
1.2 Warranty .....	4
1.3 Warnings .....	5
1.4 Table of Contents .....	6
1.5 List of Figures .....	8
1.5 About This Manual .....	13
1.6 General System Description .....	13
1.6.1 Ultrasonic Generator Models .....	14
1.6.2 Options .....	14
2 Controls .....	16
2.1 Introduction - Component Identification and Specifications .....	16
2.2 S8500 Controls .....	16
2.2.1 S8500 Control Switches .....	17
2.2.2 Adjustment Ports .....	17
2.2.3 Status Annunciators .....	18
2.3 S8300 Controls .....	19
2.4 Back Panel .....	20
3 Installation .....	22
3.1 Installation Overview .....	22
3.2 Unpacking the Ultrasonic Power Supply .....	22
3.3 Electrical Requirements .....	22
3.4 Locating the Ultrasonic Power Supply .....	22
3.5 Matching Ultrasonic Equipment .....	24
3.6 Connecting the Ultrasonic Power Supply .....	25
3.7 Ultrasonic Tank Installation .....	26
3.7.1 Overview .....	26
3.7.2 Installation Do's and Don'ts .....	27
3.7.3 Tank Features .....	28
3.7.4 Installing an Ultrasonic Tank .....	28
4 Operation .....	30
4.1 Overview .....	30
4.2 Key Concepts .....	30
4.3 U/S Mode Function .....	30
4.4 Setting the Power Level Function .....	32
4.5 Power Modulation Mode (S85 only) .....	33
4.6 Sweep Mode Function .....	34
4.6.1 S83 Sweep Mode .....	34
4.6.2 S85 Sweep Mode .....	34
4.7 Rate Function (S85 only) .....	35
4.8 Reset Function .....	36
5 System Installation .....	38
5.1 Overview .....	38
5.1.1 Do's - .....	38
5.1.2 Don'ts - .....	39
5.2 Elements - Immersible Transducers .....	39
5.3 Immersible Transducer Installation, Wiring .....	40
5.3.1 Wiring Procedures .....	40
5.3.2 Preparing the RF Cable .....	41
5.4 Immersible Installation .....	42
5.4.1 Immersible Types .....	42

5.5	Junction Boxes .....	43
5.6	Mounting Junction Boxes.....	44
5.7	Configuration Diagrams .....	45
5.7.1	12 Element Generators .....	45
5.7.2	18 Element Generators .....	46
5.7.3	24 Element generators .....	47
5.7.4	36 Element Generators .....	48
5.7.5	48 Element Generators .....	49
5.8	FC-Type Immersible Transducer Installation.....	50
5.8.1	FC Immersible Models and Dimensions .....	50
5.8.2	Mounting an FC-Type Immersible Transducer .....	51
5.8.3	Mounting FC Junction Boxes .....	52
5.8.4	Wiring One FC Immersible Transducer (12-elements shown).....	53
5.8.5	Wiring Two FC Immersible Transducers (24 elements shown).....	54
5.8.6	Wiring Three FC Immersible Transducers (36 elements shown).....	55
5.8.7	Wiring Four FC Immersible Transducers (48 elements shown).....	56
5.9	CB Type Immersible Mounting and Wiring.....	57
5.9.1	CB Type Immersible Transducer Models and Dimensions .....	57
5.9.2	Mounting a CB-Type Immersible Transducer.....	58
5.9.3	Wiring CB Immersible Transducers.....	59
5.9.4	CB-Type Immersible Transducers – 12-Element .....	60
5.9.5	CB-Type Transducers – 24-Element .....	61
5.9.6	CB-Type Immersible Transducers – 36-Element .....	62
5.9.7	CB-Type Immersible Transducers – 48-Element .....	63
5.10	Mounting and Wiring SB-Type Immersible Transducers .....	64
5.10.1	SB Type Immersible Transducer Models and Dimensions .....	64
5.10.2	Mounting an SB Type Immersible Transducer.....	65
5.10.3	Mounting and Wiring SB Type Immersible Transducers.....	66
5.11	Mounting and Wiring EB-Type Immersible Transducers .....	67
5.11.1	EB Immersible Transducer Models and Dimensions .....	67
5.11.2	Mounting an EB-Type Immersible Transducer .....	68
5.11.3	EB Type Immersible Transducer Junction Box Wiring .....	69
5.11.4	Wiring One EB/SB-Type Immersible Transducer.....	70
5.11.5	Wiring Two Immersible Transducers in Parallel.....	71
6	Troubleshooting.....	75
6.1	Periodic Maintenance .....	75
6.1.1	Ultrasonic Power Supplies.....	75
6.1.2	Tanks and Immersible Transducers .....	75
6.2	Trouble-shooting Charts .....	76
6.3	Trouble-shooting the Load .....	77
6.4	Resistance Charts .....	78
6.4.1	Overview .....	78
6.4.2	Using Resistance Charts .....	78
6.5	Assemblies.....	80
6.6	Parts List.....	80
7	Options .....	83
7.1	Full Feature Input/Output Board .....	83
7.1.1	Removing the Cover.....	83
7.1.2	Installing the I/O Board .....	84
7.1.3	I/O Board Input Signals.....	85
7.1.4	I/O Board Output Functions .....	86
7.2	OEM-I/O Board – STD-392-317.....	89
7.2.1	General .....	89
7.2.2	Kit Components.....	89
7.2.3	Installation .....	89

7.2.4	OEM I/O Operation .....	90
7.3	OEM-I/O Board – 101-063-503 .....	92
7.3.1	General.....	92
7.3.2	Kit Components .....	92
7.3.3	Installation .....	92
7.3.4	OEM I/O Operation .....	93
7.3.5	Specifications.....	93
7.4	Timer Option .....	96
7.5	Rack Mount Kit .....	97
8	Assistance .....	101
8.1	Calling the Local Branson Representative.....	101
8.2	Obtaining Replacement Parts.....	102
8.3	Returning Equipment.....	103

## 1.5 List of Figures

Figure 1-1	S8500 Ultrasonic Generator.....	13
Figure 2-1	S8500 Front Panel.....	16
Figure 2-2	S8500 Control Switches.....	17
Figure 2-3	S8500 Adjustment Ports.....	17
Figure 2-4	Status Annunciators .....	18
Figure 2-5	S8300 Front Panel.....	19
Figure 2-6	S8500 Back Panel .....	20
Figure 3-1	Ultrasonic Power supply Dimensions .....	23
Figure 3-2	Comparing Model Numbers.....	24
Figure 3-3	Translating Model Numbers .....	24
Figure 3-4	Alignment of RF Plug .....	25
Figure 3-5	Ultrasonic Tank Features .....	28
Figure 4-1	Operating US Switch S85 .....	31
Figure 4-2	Operating US Switch S83 .....	31
Figure 4-3	S85 Power Level Adjustment .....	32
Figure 4-4	Power Adjustment.....	32
Figure 4-5	S85 Setting Power Modulation Mode.....	33
Figure 4-6	Sweep Bandwidth .....	34
Figure 4-7	Sweep Adjustments.....	34
Figure 4-8	Sweep Width Adjustment .....	35
Figure 4-9	Rate Switch Operation .....	35
Figure 4-10	RESET Switch .....	36
Figure 5-1	Transducer Elements.....	39
Figure 5-2	Junction Box Terminal Connections.....	40
Figure 5-3	Task 1.....	41
Figure 5-4	Task 2.....	41
Figure 5-5	Task 3.....	41
Figure 5-6	Task 4.....	42
Figure 5-7	Mounting Configurations.....	42
Figure 5-8	Junction Boxes .....	43
Figure 5-9	Immersible Transducer Configurations 12 Elements.....	45
Figure 5-10	Immersible Transducer Configurations 18 Elements.....	46
Figure 5-11	Immersible Transducer Configurations 24 Elements.....	47
Figure 5-12	Immersible Transducer Configurations 36 Elements.....	48
Figure 5-13	Immersible Transducer Configurations 48 Elements.....	49
Figure 5-14	FC610/FC618 Mounting Dimensions .....	50
Figure 5-15	Mounting FC Type Immersibles .....	51
Figure 5-16	FC Type Immersible Transducer Junction Box Mounting.....	52



Figure 5-17 Wiring One FC Type Immersible Transducer .....	53
Figure 5-18 Wiring Two FC Type Immersible Transducers .....	54
Figure 5-19 Wiring Three FC Type Immersible Transducers .....	55
Figure 5-20 Wiring Four FC Type Immersible Transducers .....	56
Figure 5-21 CB Type Immersible Transducer Dimensions .....	57
Figure 5-22 Mounting CB Type Immersible Transducers .....	58
Figure 5-23 Mounting and Wiring CB Type Immersible Transducers .....	59
Figure 5-24 Wiring 1 CB Type Immersible Transducer .....	60
Figure 5-25 Wiring 2 CB Type Immersible Transducers .....	61
Figure 5-26 Wiring 3 CB Type Immersible Transducers .....	62
Figure 5-27 Wiring 4 CB Type Immersible Transducers .....	63
Figure 5-28 SB Type Immersible Dimensions .....	64
Figure 5-29 Mounting an SB Type Immersible Transducer .....	65
Figure 5-30 Wiring SB Junction Boxes .....	66
Figure 5-31 EB Type Immersible Transducer Dimensions .....	67
Figure 5-32 Mounting an EB Type Immersible Transducer .....	68
Figure 5-33 EB Immersible Transducer Junction Box Wiring .....	69
Figure 5-34 Wiring 1 EB/SB Type Immersible Transducer .....	70
Figure 5-35 Wiring 2 or More EB/SB Type Immersible Transducers .....	71
Figure 6-1 Driver Board Test Points .....	79
Figure 6-2 Ultrasonic Power Supply Top View .....	80
Figure 6-3 Interconnection Diagram .....	81
Figure 7-1 Removing The Cover .....	83
Figure 7-2 Installing Standoffs .....	84
Figure 7-3 Installing I/O Board .....	84
Figure 7-4 Connector J2 .....	85
Figure 7-5 Discrete Input - Sinking Input Type – 6 Points .....	87
Figure 7-6 Discrete Outputs – Normally Open Contacts – 2 Points .....	87
Figure 7-7 Analog Input - 1 Point .....	88
Figure 7-8 Analog Output - 2 Points .....	88
Figure 7-9 OEM-I/O Board Installation .....	91
Figure 7-10 OEM I/O Configuration .....	93
Figure 7-11 External Wiring Diagrams .....	94
Figure 7-12 OEM I/O Installation .....	95
Figure 7-13 Timer Option .....	96
Figure 7-14 Rack Mount Kit .....	97



---

# **S83/85 Ultrasonic Generator**

## **A40-064**



---

## 1.5 About This Manual

This manual contains instructions for installing, operating and maintaining S83/85 Ultrasonic Generators.

At the back of the manual you will find Appendices containing documentation including wiring schematics, plumbing schematics and assembly drawings.

The following definitions apply in this manual:

**Note:** Inconvenience only if disregarded - no damage or personal injury.

**Caution:** Equipment damage may occur, but not personal injury.

**Warning:** *Personal injury may occur - DO NOT DISREGARD.*

PN indicates Part Number.

Part(s) indicates your workpiece or component to be cleaned.

**Figure 1-1 S8500 Ultrasonic Generator**

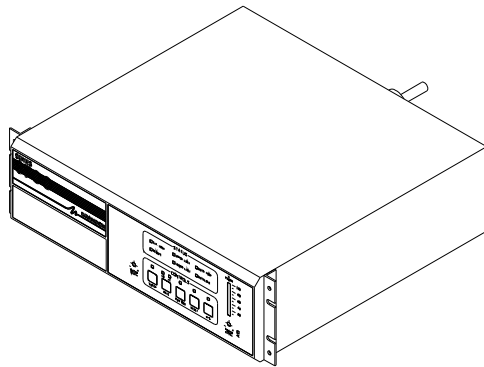

## 1.6 General System Description

Series 83/85 Ultrasonic Power Supplies deliver ultrasonic electrical energy at 25 kHz, 40 kHz, 80 kHz, 120 kHz or 170 kHz (depending on the model) to an ultrasonic cleaning system. A typical system consists of an ultrasonic power supply and a cleaning tank or immersible. Optional full feature or OEM interface boards allow the generator to be configured and operated remotely.

**Note:** Series 83/85 ultrasonic power supplies only work with Branson ultrasonic equipment (tanks and immersible transducers).

## 1.6.1 Ultrasonic Generator Models

Table 1 Ultrasonic Generator Models

Part Number	Series	Model	Voltage	Nominal Power level	Number of elements	Standard Groupings
101-132-468	8300	S8325-12	120 VOLT	500W	12	1x12 or 2x6
101-132-469		S8325-12	230 VOLT	500W	12	1x12 or 2x6
101-132-471		S8325-18	"	750W	18	1x12 & 1x6 or 3x6
101-132-472		S8325-24	"	1000W	24	2x12 or 4x6
101-132-473		S8325-36	"	1500W	36	3x12 or 6x6
101-132-474		S8325-48	"	2000W	48	4x12 or 8x6
101-132-475		S8340-12	120 VOLT	500W	12	1x12 or 2x6
101-132-476		S8340-12	230 VOLT	500W	12	1x12 or 2x6
101-132-478		S8340-18	"	750W	18	1x12 & 1x6 or 3x6
101-132-479		S8340-24	"	1000W	24	2x12 or 4x6
101-132-480		S8340-36	"	1500W	36	3x12 or 6x6
101-132-481		S8340-48	"	2000W	48	4x12 or 8x6
101-132-482	8500	S8525-12	120 VOLT	500W	12	1x12 or 2x6
101-132-483		S8525-12	230 VOLT	500W	12	1x12 or 2x6
101-132-485		S8525-18	"	750W	18	1x12 & 1x6 or 3x6
101-132-486		S8525-24	"	1000W	24	2x12 or 4x6
101-132-487		S8525-36	"	1500W	36	3x12 or 6x6
101-132-488		S8525-48	"	2000W	48	4x12 or 8x6
101-132-489		S8540-12	120 VOLT	500W	12	1x12 or 2x6
101-132-490		S8540-12	230 VOLT	500W	12	1x12 or 2x6
101-132-492		S8540-18	"	750W	18	1x12 & 1x6 or 3x6
101-132-493		S8540-24	"	1000W	24	2x12 or 4x6
101-132-494		S8540-36	"	1500W	36	3x12 or 6x6
101-132-495		S8540-48	"	2000W	48	4x12 or 8x6
101-132-682	80kHz	S8580-12	230V	500W	12	1x12 or 2x6
101-132-683	"	S8580-18	"	750W	18	1x12 & 1x6 or 3x6
101-132-684	"	S8580-24	"	1000W	24	2x12 or 4x6
101-132-685	120kHz	S85120-12	"	500W	12	1x12 or 2x6
101-132-686	"	S85120-18	"	750W	18	1x12 & 1x6 or 3x6
101-132-687	170kHz	S85170-6	"	250W	6	1x6
101-132-688	"	S85170-12	"	500W	12	1x12 or 2x6

## 1.6.2 Options

Table 2 Generator Options

Part Number	Type	Description
101-063-347		Rack mount kit
101-063-503	I/O KIT	OEM ON/OFF with status indication
101-063-561	I/O KIT	FULL FEATURE, S8500 only
STD-392-317	I/O KIT	OEM ON/OFF with external interlock
STD-410-901	TIMER	0-60 Mechanical Timer

---

# **S83/85 Ultrasonic Generator**

## **A40-064**

## 2 Controls

### 2.1 Introduction - Component Identification and Specifications

Operating the ultrasonic power supply requires that you become familiar with the power supply controls, annunciators, and adjustment function.

The front panel contains the following:

- Control switches;
- Status annunciators;
- Adjustment ports.

### 2.2 S8500 Controls

Figure 2-1 S8500 Front Panel

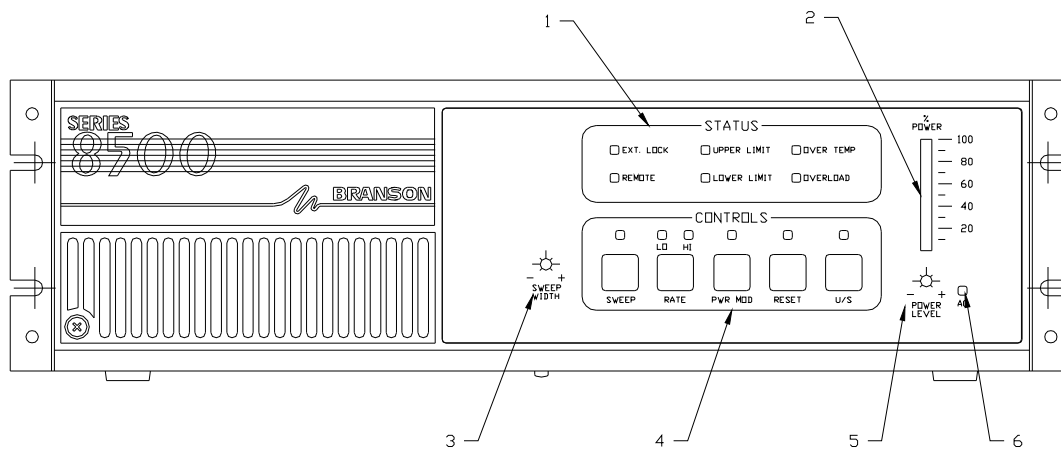

Item No.	Description	Function
1	Status annunciators	Light when fault conditions occur.
2	Ultrasonic (U/S) Power Bargraph	Displays the percentage of ultrasonic power input.
3	Sweep Width Adjustment port	Allows adjustment bandwidth of the Sweep mode.
4	Ultrasonic power supply control switches	Contains switches to control ultrasonic power supply functions and status annunciators.
5	Power Level Adjustment port	Allows manually setting the ultrasonic power level.
6	AC Power	Lights when the On/Off switch is on and the ultrasonic power supply has main AC power.



## 2.2.1 S8500 Control Switches

Figure 2-2 S8500 Control Switches

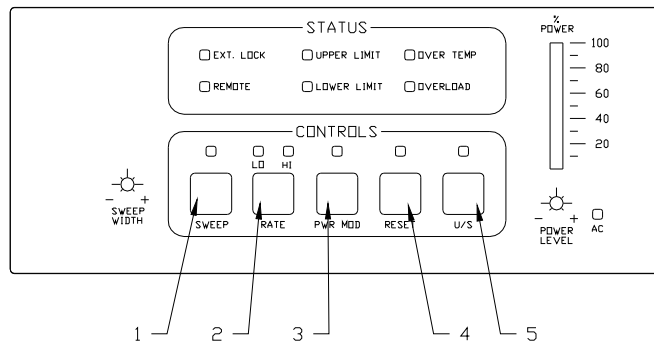

Item No.	Switch	Function
1	SWEEP	Activates Sweep mode; LED is on when sweep is on.
2	RATE	Toggles between high (“HI” LED on) and low (“LO” LED on) Sweep Rates. Power On default is HIGH rate.
3	POW MOD	Activates the Power modulation mode; LED is on when Power Modulation is on.
4	RESET	Press when the LED is on to reset the ultrasonic power supply and turn the LED off.
5	U/S	Activates ultrasonic output power; LED is on when ultrasonics are on

## 2.2.2 Adjustment Ports

Figure 2-3 S8500 Adjustment Ports

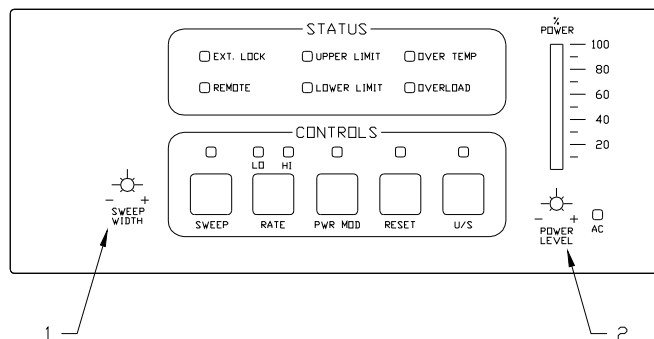

Item No.	Adjustment Port	Function
1	Sweep Width	Adjusts the Sweep mode bandwidth.
2	Power Level	Adjusts the percentage of ultrasonic output power (20-100%).

## 2.2.3 Status Annunciators

Figure 2-4 Status Annunciators

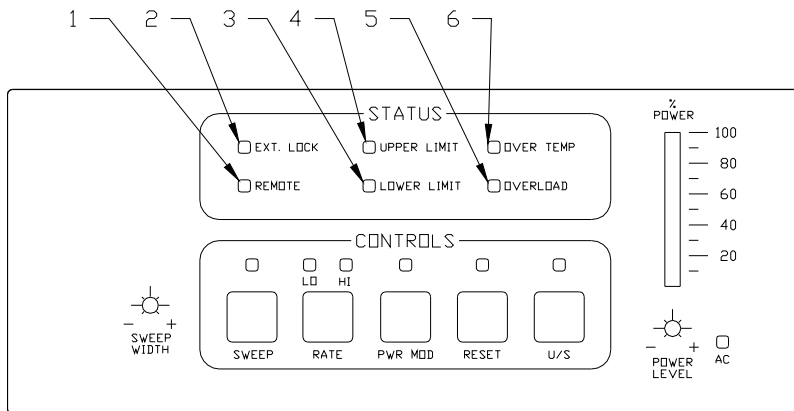

Item No.	Annunciator	Function
1	REMOTE (with I/O option only)	Annunciator lights when the back panel REMOTE/LOCAL switch is in “REMOTE” position. Note: When operating the ultrasonic power supply in REMOTE position, you cannot activate the following front panel control switches: <ul style="list-style-type: none"> <li>• SWEEP</li> <li>• RATE</li> <li>• POW MOD</li> </ul>
2	EXT. LOCK	Annunciator lights: (a) when the RF cable is not connected to the ultrasonic power supply, or (b) when it receives a fault condition externally via the I/O port. Power supply is in standby mode when light is on.
3	LOWER LIMIT	Annunciator lights when the power level drops 20% below the preset power level. Power supply is in standby mode when light is on.
4	UPPER LIMIT	Annunciator lights when the power level exceeds the preset power level by 20%. Power supply is in standby mode when light is on.
5	OVER LOAD	Annunciator lights when the ultrasonic power supply overloads due to no-load, or overload condition. Power supply is in Standby mode when light is on.
6	OVER TEMP	Annunciator lights when the ultrasonic power supply detects an excessive internal temperature. Power supply is in standby mode when light is on.

## 2.3 S8300 Controls

Figure 2-5 S8300 Front Panel

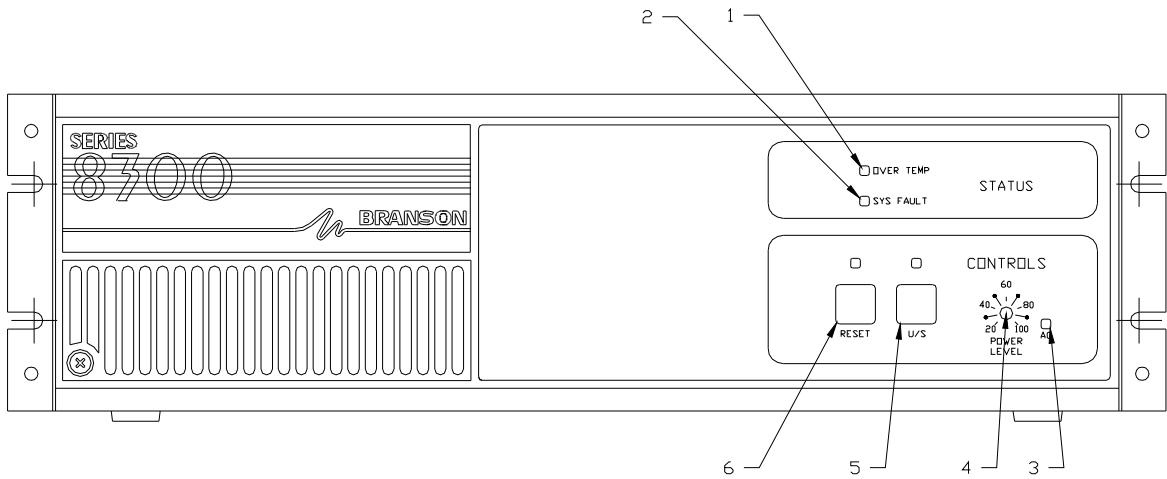

Item No.	Control	Function
1	OVER TEMP	Annunciator lights when the ultrasonic power supply detects an excessive internal temperature. Power supply is in standby mode when light is on.
2	SYS FAULT	Annunciator lights when the ultrasonic power supply detects an overload, out of range power level or an external fault condition via the I/O port. Power supply is in standby mode when light is on.
3	AC	Lights when the On/Off switch is on and the ultrasonic power supply has main AC power.
4	US	Activates ultrasonic output power; LED is on when ultrasonics are on
5	RESET	Press when the LED is on to reset the ultrasonic power supply and turn the LED off.

## 2.4 Back Panel

Figure 2-6 S8500 Back Panel

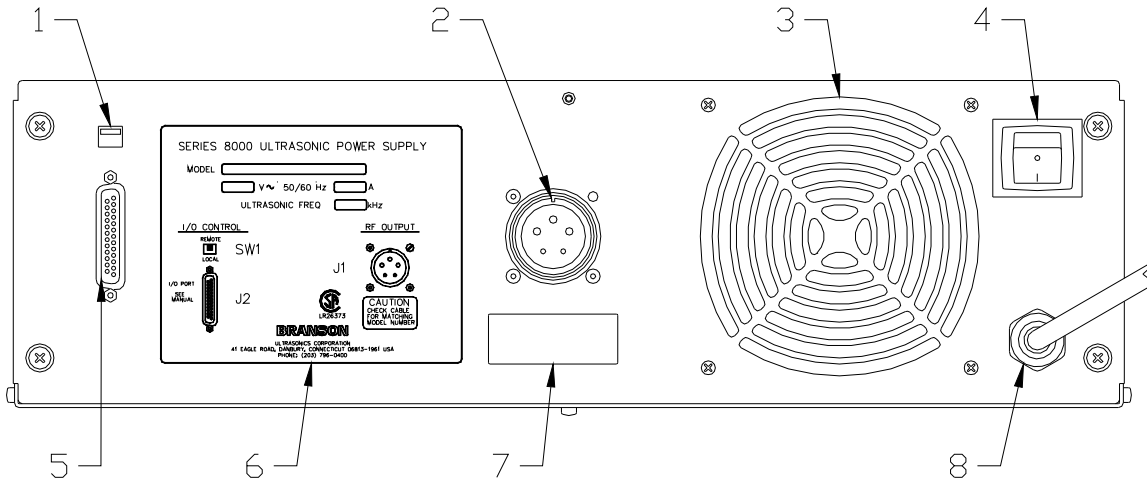

Item No.	Description	Function
1	Local/Remote switch SW1	Allows switching between local and remote operation.
2	RF Connector	For connecting the RF cable to the ultrasonic power supply from a tank or immersible transducers.
3	Fan	Cools the ultrasonic power supply by exhausting hot air.
4	Main On/Off Switch	Switches on AC power to the ultrasonic power supply.
5	I/O 25-pin D-shell connector (I/O option only).	Provides connection of cable from ultrasonic power supply to external controller.
6	Product Label	Displays product information, such as power level, frequency, and serial no.
7	Serial number tag	Displays serial number of the ultrasonic power supply.
8	Line Cord	Connects ultrasonic power supply to AC power.

---

# **S83/85 Ultrasonic Generator**

## **A40-064**

---

## 3 Installation

### 3.1 Installation Overview

This section contains a sequence of tasks you must follow to ensure proper installation of your ultrasonic power supply and ultrasonic tank. These tasks include:

1. Unpacking the ultrasonic power supply.
2. Choosing a suitable location for the ultrasonic power supply.
3. Matching ultrasonic equipment (ultrasonic power supply to tanks and immersible transducers).
4. Connecting the ultrasonic power supply.
5. Installing an ultrasonic tank.

### 3.2 Unpacking the Ultrasonic Power Supply

Unpack the ultrasonic power supply as follows:

Step	Action
1	Unpack the ultrasonic power supply as soon as it arrives, using normal precautions to prevent damage.
2	Inspect the controls, indicators, and surface for damage.
3	Make sure that all switches are off.

**Note:** If damage occurred, notify the shipping company immediately. Retain packing materials for inspection.

### 3.3 Electrical Requirements

Standard line voltage: 187-253 VAC 50/60 Hz  
108-132 VAC 50/60 Hz (120 Volt models)

**Table 3 Current Draws (Amps)**

Elements	208V	230V	120V
12	2.2	2	4
18	3.3	3	
24	4.4	4	
36	6.6	6	
48	8.8	8	

### 3.4 Locating the Ultrasonic Power Supply

Locate the ultrasonic power supply according to the following guidelines:

- Make sure the ambient air temperature where you locate and operate the ultrasonic power supply does not exceed 45°C (113°F).
- Make sure air flow to the fan is not obstructed.
- Locate the ultrasonic power supply in a electrically non-conductive atmosphere.
- Make sure to locate the ultrasonic power supply in an area free from water spray, splashing, and dripping.
- Ground the ultrasonic power supply receptacle in accordance with local building codes.

- Allow sufficient clearance to access connectors on back of the ultrasonic power supply (7 in. minimum).
- Place the ultrasonic power supply on a horizontal, flat surface top near the tank or transducer in an area away from any heat sources.

**Figure 3-1 Ultrasonic Power supply Dimensions**

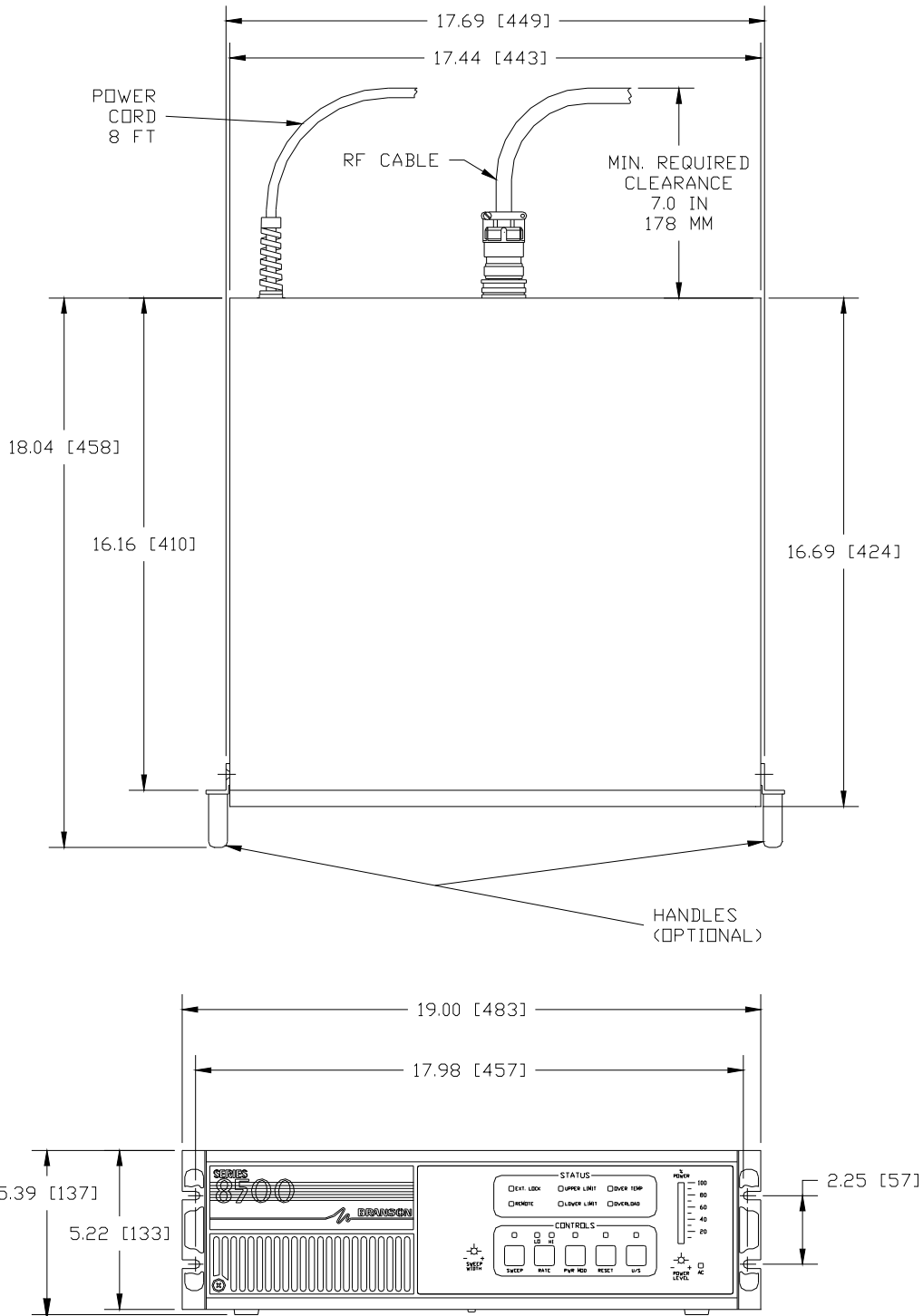

### 3.5 Matching Ultrasonic Equipment

Compare the model numbers on all equipment connected to the ultrasonic power supply. Figure 3-2 shows the labels that contain the model numbers.

Figure 3-2 Comparing Model Numbers

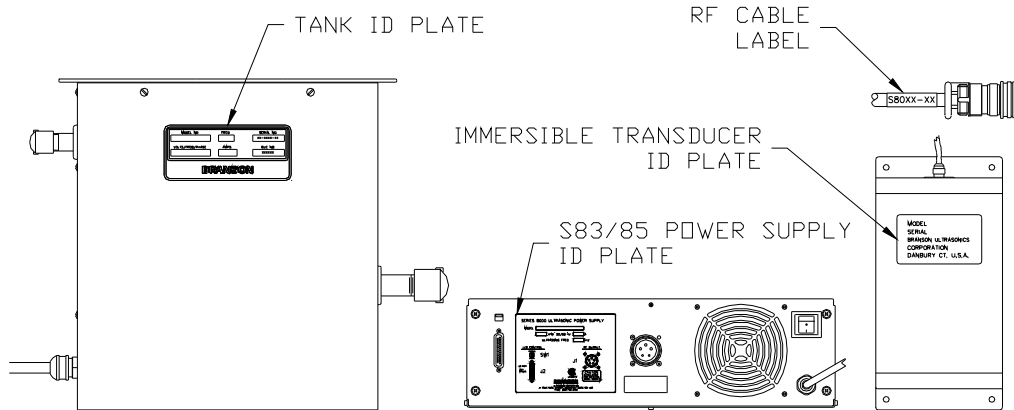
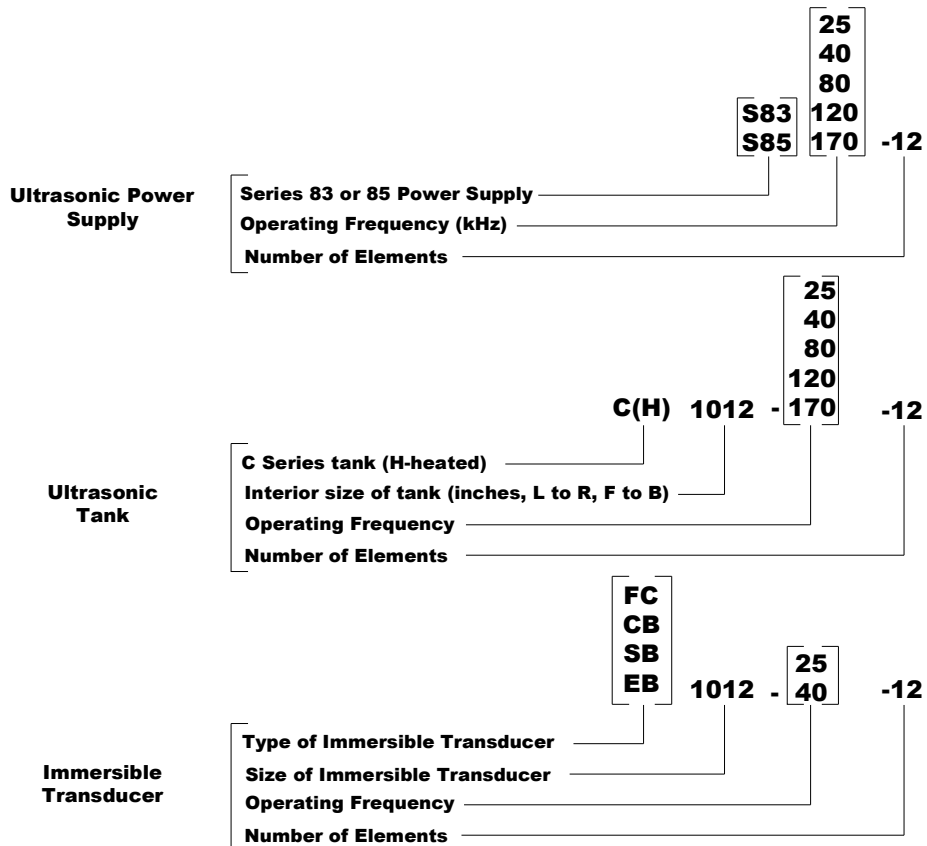

Figure 3-3 Translating Model Numbers



Note: Use 40 kHz transducer with 80, 120 and 170 kHz generators.



### 3.6 Connecting the Ultrasonic Power Supply

Connect the ultrasonic power supply as follows:

Step	Action
1	Make sure that the ultrasonic power supply is unplugged from the AC voltage source.
2	Make sure the Main On/Off switch (located on the back panel) is off.
3	Align the notch of the RF cable and the slot of RF connector on the back panel (Figure 3-4 shows the alignment).
4	Plug the RF plug into the RF socket; secure the RF plug by threading the knurled ring and turning until the end of travel.

Figure 3-4 Alignment of RF Plug

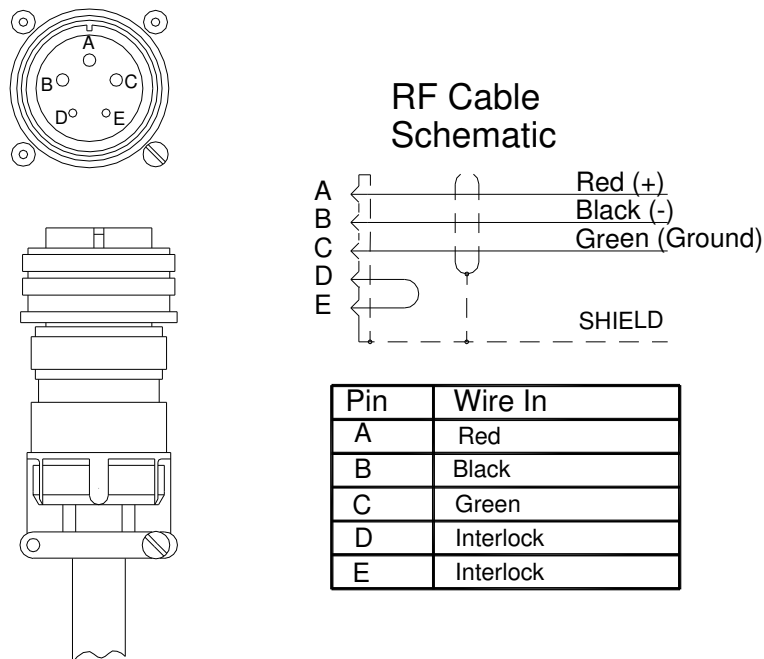

**Note:** If the RF connector is not fully engaged by the knurl ring, the External Lock LED will light.

---

## 3.7 Ultrasonic Tank Installation

### 3.7.1 Overview

This section contains instructions for installing and operating a Branson ultrasonic tank with the S8000 ultrasonic power supply. The following tables contain model numbers and part numbers for unheated and heated ultrasonic tanks.

**Table 4 Ultrasonic Tanks - Unheated**

Model	Part No. – Chromated	Part No. – Bright Annealed Finish
C1012-25-12	101-908-202	101-908-228
C1216-25-18	101-908-206	101-908-227
C1620-25-24	101-908-210	101-908-223
C2024-25-36	101-908-214	101-908-219
C1012-40-12* @ &	101-908-200	101-908-229
C1216-40-18* @	101-908-204	101-908-226
C1620-40-24*	101-908-208	101-908-221
C2024-40-36	101-908-212	101-908-218

**Table 5 Ultrasonic Tanks - Heated**

Model	Part No. – Chromated	Part No. – Bright Annealed Finish
CH1012-25-12	101-908-203	101-908-230
CH1216-25-18	101-908-207	101-908-225
CH1620-25-24	101-908-211	101-908-222
CH2024-25-36	101-908-215	101-908-216
CH1012-40-12* @ &	101-908-201	101-908-231
CH1216-40-18* @	101-908-205	101-908-224
CH1620-40-24*	101-908-209	101-908-220
CH2024-40-36	101-908-213	101-908-217

- \* May be operated with 80 kHz generator
- @ May be operated with 120 kHz generator
- & May be operated with 170 kHz generator

---

### 3.7.2 Installation Do's and Don'ts

1. DO make sure you have all necessary system components: the RF cable, the interconnecting jumper cables, and the junction boxes.
2. DO ensure that the frequency and number of elements (transducers) of the ultrasonic power supply matches that of the ultrasonic tank load.
3. DO compare the numbers on the RF cable label and the ID plate on the back panel of the ultrasonic power supply to make sure they match.
4. DO turn off main power switches.
5. DO make sure to ground the ultrasonic power supply in accordance with local building and safety codes.
6. DO check the line voltage on the ID plate for the ultrasonic power supply line voltage to ensure it matches your AC source voltage
7. DO use Power Modulation mode – after initially filling the ultrasonic tank – to remove large obstructive gas bubbles which shield the ultrasonic energy. Run for 10-15 minutes at operating temperature.
8. DO maintain the liquid level of the ultrasonic tank with 3 inches of the top – the same level as the fill port.
9. DO, in application with large parts which displace significant amount of liquid, take care not to expose the heaters.
10. DO make sure to operate an ultrasonic tank from the same ultrasonic power supply.
11. DO ensure parts are at least 2 inches from the radiating surface of the ultrasonic tank or immersible transducers. Do this by positioning a basket or parts rack to maintain the 2-inch minimum distance.
12. DO ensure parts slowly agitate up and down while ultrasonic cleaning. This enhances the cleaning process by flushing away the contaminates as cavitation removes them.
13. DO make sure to open/expose parts to the ultrasonic field as much as possible.
14. DO use baskets constructed of ¼ inch mesh or larger. For small parts, DO use near solid bottom baskets.

#### Don'ts

1. DO NOT place parts directly on the radiating surface of an ultrasonic tank or immersible.
2. During the cleaning process, DO limit the disturbance of the liquid. Limit flow from fills or recirculation to 4-5 gallons per minute.
3. DO NOT ever use highly acidic compounds or flammable chemistries – the C/CH tank series and immersible transducers are constructed of 316L stainless steel.
4. DO NOT plug the ultrasonic power supply to AC source until you finish installing the ultrasonic tank or tank with immersible transducers.
5. DO NOT operate the ultrasonic power supply with the cover off.

**Caution:** Check the model number of the ultrasonic power supply and the model numbers on the ultrasonic tank that you plan to install. *Equipment damage can occur if the ultrasonic power supply model number does not match the number of elements in the ultrasonic tank.*

Before installing, make sure that you turn off the ultrasonic power supply and disconnect your AC voltage source. Leave the ultrasonic power supply disconnected until you finish the installation.

### 3.7.3 Tank Features

The following figures contain illustrations of the right side and left side of an ultrasonic tank (CH1012-25-12 shown). The illustration contain callouts to the features of the ultrasonic tank that you need to know to install and operate an ultrasonic tank.

Figure 3-5 Ultrasonic Tank Features

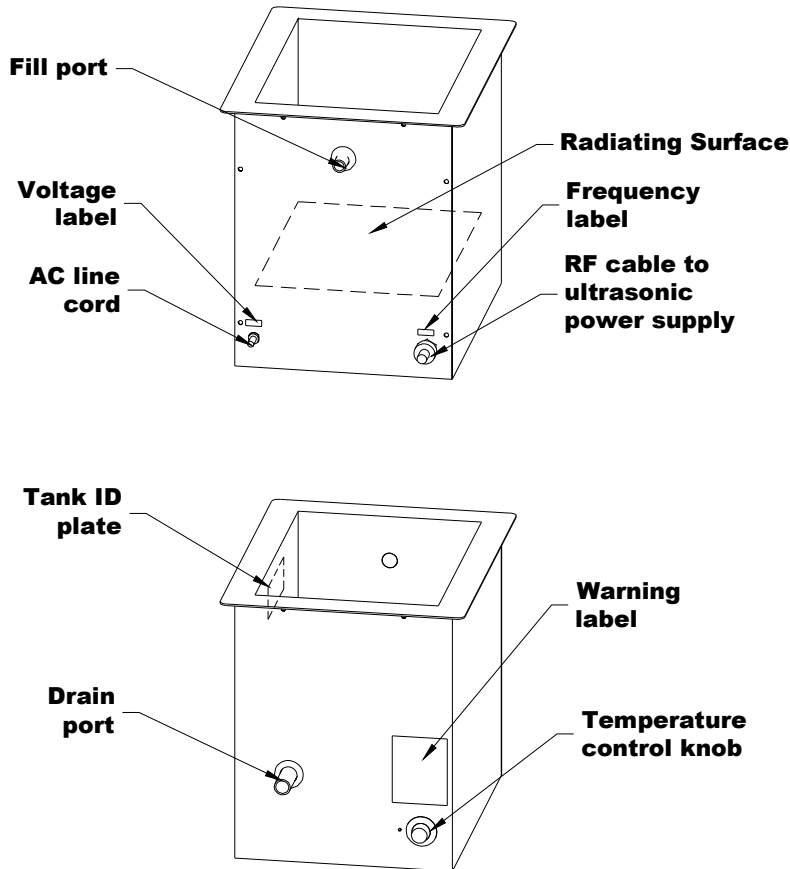

### 3.7.4 Installing an Ultrasonic Tank

Step	Action
1	Check tank plumbing; make sure drain is closed.
2	If using a heated tank, set temperature control to lowest setting.
3	Fill the tank with liquid to the 3 inches from the top – the same level as the fill port.
4	If using a heated tank, plug in the heater.
5	Plug RF cable into power supply.
6	Turn on the ultrasonic power supply.
7	If using a heated tank, set the tank temperature.
8	Place parts in basket.

---

# **S83/85 Ultrasonic Generator**

## **A40-064**

---

## 4 Operation

### 4.1 Overview

This section contains instructions for starting and operating the ultrasonic power supply and covers the following:

- Using the U/S switch to activate ultrasonics.
- Setting the power level.
- Using Power modulation mode to remove dissolved gases from the tank liquid.
- Using Sweep mode to select the sweep speed and bandwidth.
- Using the Rate switch to set sweep speed.
- Using the Reset switch when tuning and when clearing a fault condition.

The order of the topics above is the most common sequence used to operate the ultrasonic power supply.

### 4.2 Key Concepts

The following defines key concepts used when operating the ultrasonic power supply:

*Line/load regulation* – compensates for the tank liquid level and temperature changes as well as line and load variations. This maintains power to less than 3 percent change for consistent cleaning.

*Auto frequency tracking* – maintains optimum operating frequency around your application. Dynamically adjusts to your preset conditions regardless of changes in your operating environment.

*Sweep mode* – modulates the operating frequency above and below the ultrasonic power supply's tuned frequency by approximately 1000 Hz. This feature produces a random wave-length pattern in the tank to improve energy distribution and cleaning effectiveness.

*Power modulation* – Changes the ultrasonic waveform to provide high amplitude to assist in cavitating viscous or difficult to cavitate liquids. The average power level is unchanged. Power modulation may be used to improve degassing in difficult to degas liquids.

### 4.3 U/S Mode Function

The U/S control switch activates ultrasonic power to the ultrasonic tank or immersible transducers.

**Notes** You can operate the U/S control switch at the front panel when in operating the ultrasonic power supply in Remote position.

**Note:** Before pressing the U/S control switch, make sure the ultrasonic power supply is powered up and the connection to the ultrasonic tank or immersible transducers is secure.

**Figure 4-1 Operating US Switch S85**

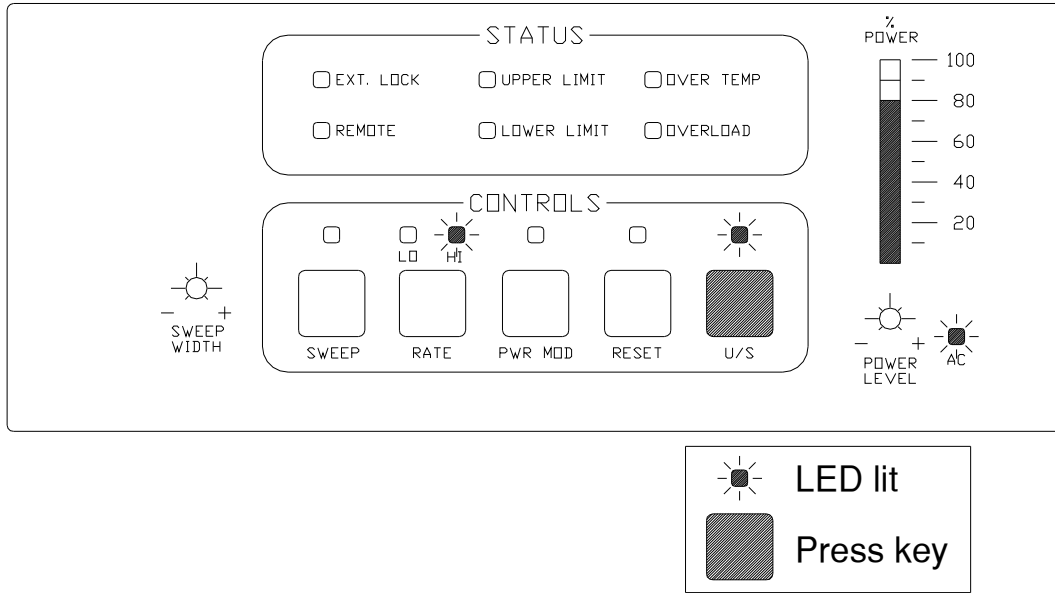

**Figure 4-2 Operating US Switch S83**



Press the U/S switch. The U/S power level will slowly ramp to the maximum setting determined by: (a) the power level setting or (b) the external DC control voltage (in Remote position).  
The S85 generator will display the power level on the bar graph.

## 4.4 Setting the Power Level Function

The Power Level Adjustment Port allows to set the ultrasonic output power level from 20% to 100% of the maximum power rating of your ultrasonic power supply.

**Notes:** If operating the ultrasonic power supply in Remote position, the front panel power level setting no longer applies.

**Note:** If the RESET light is illuminated, you cannot adjust the U/S power.

Figure 4-3 S85 Power Level Adjustment

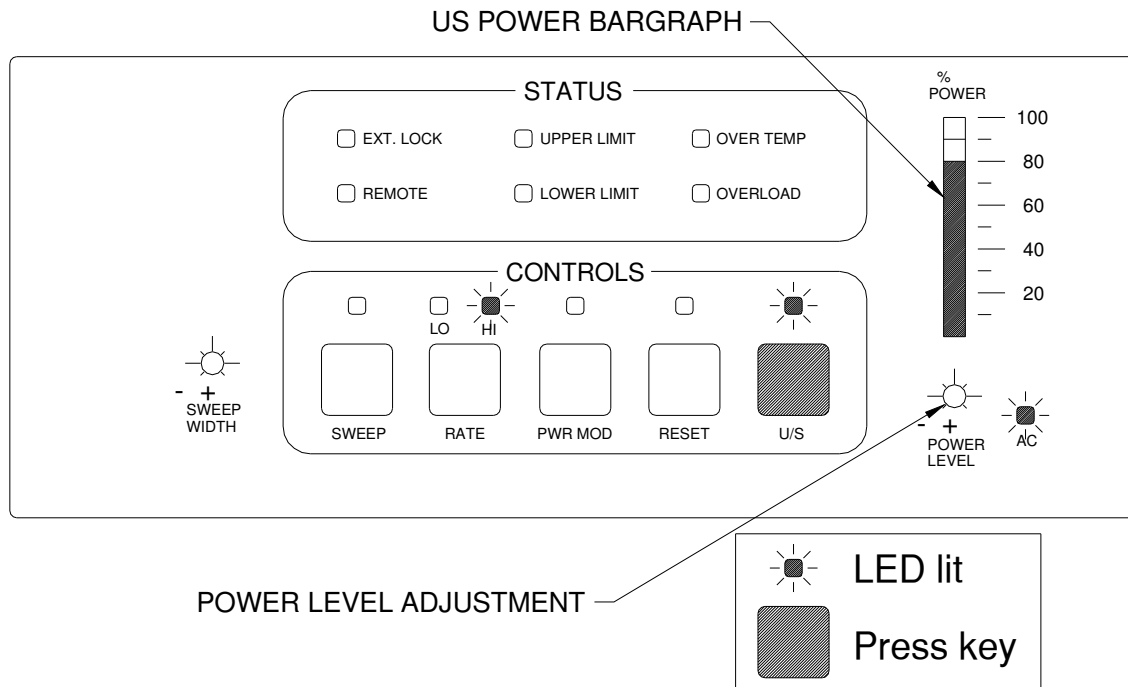

Step	Action	Result
1	Press the U/S switch.	U/S LED lights.
2	Turn the Power Level Adjustment Port to set the Power Level. <b>Figure 4-4 Power Adjustment</b>	The U/S Power bargraph displays the power level on the S85 generator. There is no display on the S83 generator.

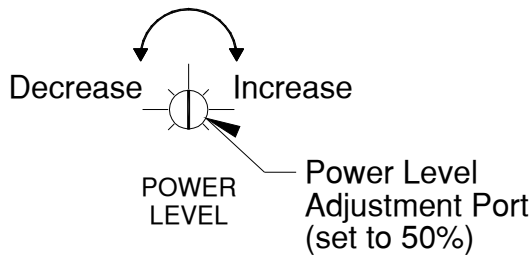



## 4.5 Power Modulation Mode (S85 only)

Power modulation creates power bursts at a 4 : 1 ratio between peak power and the average power. When not in power modulation, the ratio between the peak and average power is 2:1. This feature is helpful when working with liquids that are normally difficult to cavitate such as semi-aqueous solutions. Activate power modulation by pressing the PWR MOD button on the front panel.

- The generator must be off to enter the power modulation mode.
- Sweep will be inactive in the power modulation mode.
- Power modulation can be set from the panel when operating in the remote mode.

Figure 4-5 S85 Setting Power Modulation Mode

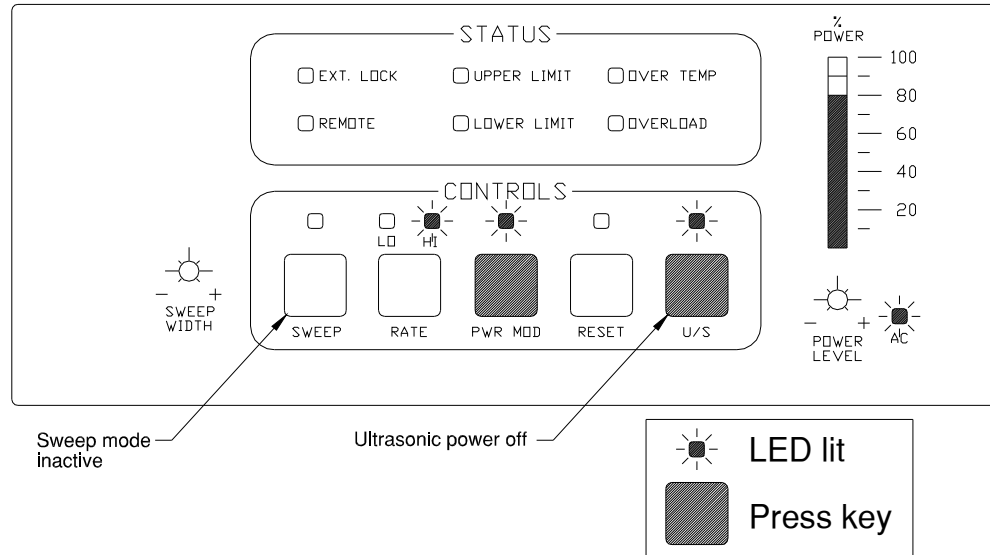

Step	Action	Result
1	Power up the ultrasonic power supply and make sure that U/S LED is off.	AC LED on; U/S LED off.
2	Press two control switches in this order (a) POW MOD and (b) U/S.	POW MOD LED lights; Tank liquid agitates.
3	To turn POW MOD off: press the U/S switch.	U/S Off
4	Press the POW MOD switch.	POW MOD mode inactive and the LED goes off.
5	Press the U/S switch.	Ultrasonic power supply returns to standard operating mode.

## 4.6 Sweep Mode Function

### 4.6.1 S83 Sweep Mode

Sweep is always on at a fixed rate of 80 Hz and a bandwidth of +/- 700Hz.

### 4.6.2 S85 Sweep Mode

Sweep Mode allows the ultrasonic power supply to operate above and below the operating frequency. In Sweep mode, the operating frequency constantly changes, sweeping from 1000 Hz below to 1000 Hz above the operating frequency. This helps cleaning activity in the tank. The following figure shows the bandwidth:

Figure 4-6 Sweep Bandwidth

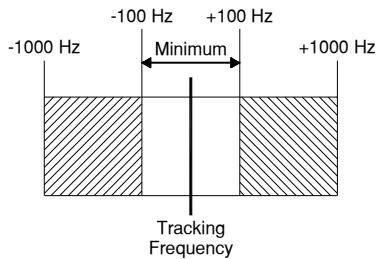

Two other functions are used to set Sweep: the Rate function and the Sweep Width Adjustment port.

**Notes: Sweep mode becomes inactive at the front panel when operating the ultrasonic power supply in Remote mode or Power modulation mode.**

Before pressing the SWEEP button, make sure that:

- You have the adjustment tool (supplied with the ultrasonic power supply) or 1/8" flat-blade screwdriver for adjusting the Sweep adjustment potentiometer; and
- The ultrasonic power supply is powered up.

Figure 4-7 Sweep Adjustments

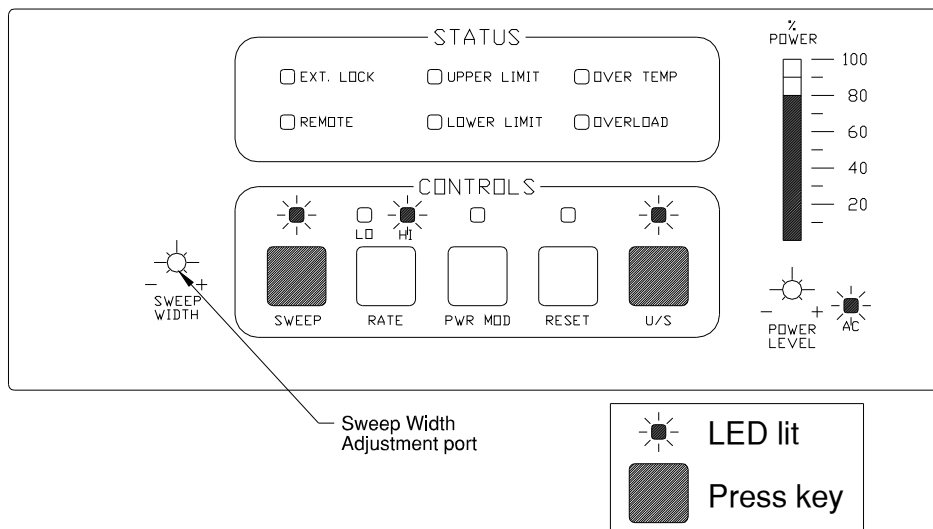

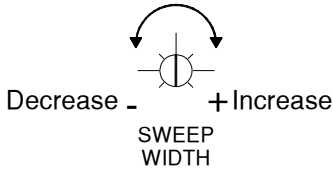
Step	Action	Result
1	Press the Sweep switch.	Sweep LED lights.
2	Press Rate to select 80 Hz (LO) or 1000 Hz (HI).	Rate HI or LO led lights. Refer to <i>Rate</i> on next page.
3	Turn the Sweep Width adjustment port to set the bandwidth.  <b>Figure 4-8 Sweep Width Adjustment</b>  	
4	Press the Sweep switch.	Sweep LED goes off.
5	Press the U/S switch.	Ultrasonics activates.

#### 4.7 Rate Function (S85 only)

The Rate switch allows you to select the speed at which the ultrasonic power supply will sweep about the operating frequency. (Low rate (LO) = 80 Hz; high rate (HI) = 1 kHz.)

- Rate is inactive at the front panel when operating the ultrasonic power supply in Remote mode.
- Upon powerup, Rate defaults to HI.
- The Rate switch is used in conjunction with Sweep Mode; refer to Sweep mode, for instructions on using the Rate function.
- Press the RATE switch to toggle between HI and LO (Low).

**Figure 4-9 Rate Switch Operation**

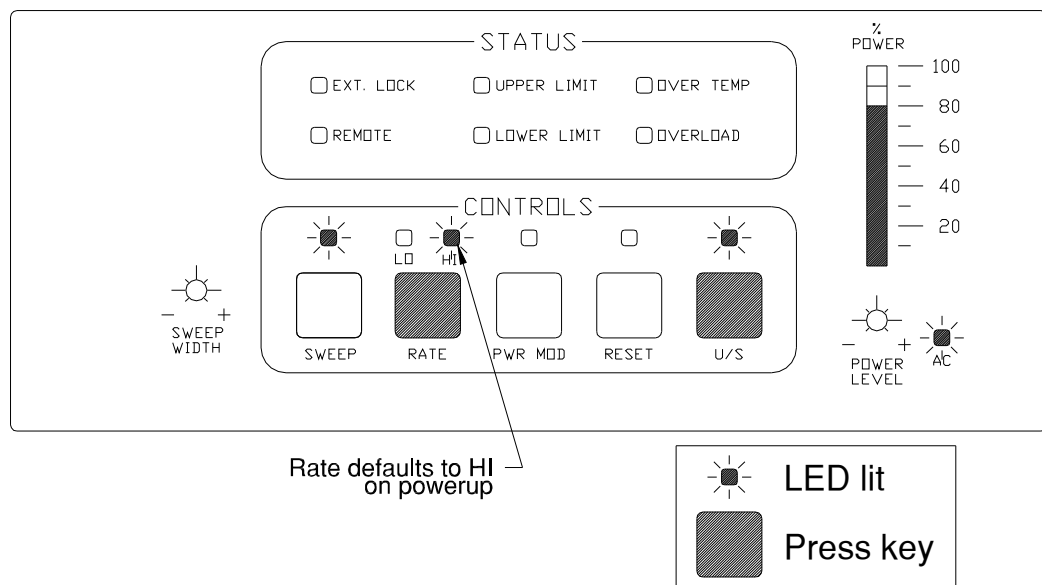

## 4.8 Reset Function

The Reset function activates when a fault occurs, as indicated by a lit LED in the Status area. You activate Reset when you fix the fault and want to return to standard operating mode.

Before pressing Reset, all alarms must be resolved, and all status LEDs must be off (except REMOTE).

Press the RESET switch to turn the indicator off and allow the ultrasonics to be restarted. Removing AC power will also reset the fault condition.

Figure 4-10 RESET Switch

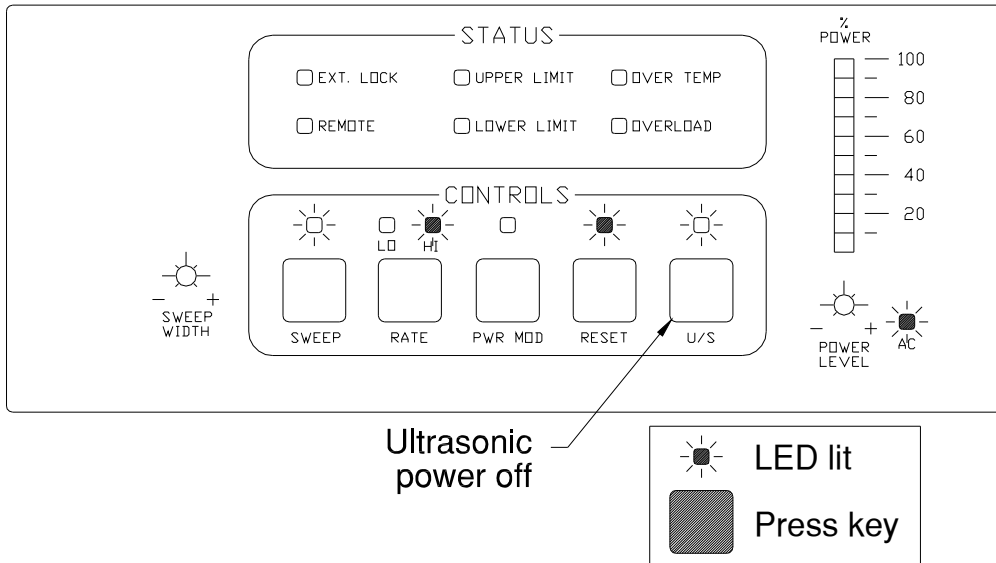

---

# **S83/85 Ultrasonic Generator**

## **A40-064**

---

## 5 System Installation

### 5.1 Overview

This section is for a customer who installs Branson custom tanks with Branson immersible transducers.

All four types of immersible transducers – FC, CB, SB, and EB – mount on the sidewall or bottom of a custom ultrasonic tank. To connect an immersible transducer or group of immersible transducers to the power supply, you use one or more types of junction boxes.

This section details how to:

- Mount and wire the junction boxes;
- Mount and wire the immersible transducers.

**Caution:** Check the model number of the power supply and the model numbers on each immersible transducer that you plan to install. Equipment damage can occur if the ultrasonic power supply model number does not match the number of elements connected.

Before installing, make sure that you:

- Turn off the power supply and disconnect your AC voltage source; leave disconnected until you finish the installation.
- Drain the tank completely.
- Wire all RF connections in parallel according to the wiring diagrams.

#### Installation Do's and Don'ts

Before installing equipment, read the following Do's and Don'ts:

##### 5.1.1 Do's –

1. DO make sure you have all necessary system components: the RF cable, the interconnecting jumper cables, and the junction boxes.
2. DO ensure that the frequency and number of elements (transducers) of the ultrasonic power supply matches that of the ultrasonic tank or the total immersible transducer load.
3. DO compare the numbers on the RF cable ID label and the ID plate on the back panel of the ultrasonic power supply to make sure they match.
4. DO turn off main power switches.
5. DO wire all immersible transducers in parallel (red-red, black-black).
6. DO make sure to ground the ultrasonic power supply in accordance with local building and safety codes.
7. DO check the line voltage on the ID plate for the ultrasonic power supply line voltage to ensure it matches you AC source voltage.
8. DO use stainless steel hardware whenever possible; usually #10-32 panhead screws or #10-32 weld studs, washers, and nuts.
9. DO install immersible transducers before installing junction boxes.
10. DO prepare the RF cable before installing RF cables into junction boxes. (Refer to Preparing an RF Cable).
11. DO install FC-type immersible transducers on a mounting rack that hangs over the tank sidewall or on the bottom of the tank. The rack must be fabricated of tank-like material, such as 316SL stainless steel.

- 
12. DO use weld studs (10-32x1/2 316 stainless steel) when mounting immersible transducers on a tank.
  13. DO make sure to install immersible transducers, placed on opposing walls of a tank, so they are no closer than 10 inches.
  14. DO make sure to operate an ultrasonic tank or set of immersible transducers from the same ultrasonic power supply.
  15. DO install protective guards on side-mounted immersible transducers.

#### 5.1.2 Don'ts –

1. DO NOT operate the ultrasonic power supply with the cover off.
2. DO NOT plug the ultrasonic power supply to AC source voltage until you finish installing the ultrasonic tank or tank with immersible transducers.
3. DO NOT scratch or mar a radiating surface of an immersible transducer.

## 5.2 Elements – Immersible Transducers

Figure 5-1 contains an illustration of an immersible transducer with an array of transducers. Ultrasonic tanks also contain transducer arrays. For example, a C1012-25-12 model ultrasonic tank contains 12 transducers. For use in this manual, the individual transducers in an immersible transducer or ultrasonic tank are defined as elements. So throughout this manual, note that a 12-element immersible transducer contains 12 transducers, a 24-element transducer contains 24 transducers, and so on.

**Figure 5-1 Transducer Elements**

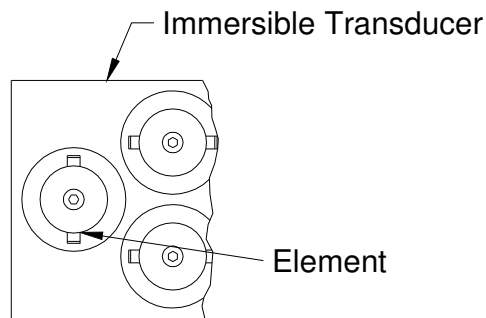

---

## 5.3 Immersible Transducer Installation, Wiring

### 5.3.1 Wiring Procedures

The following table contains steps for wiring a junction box.

**Note:** These steps apply when wiring *all three styles* of junction boxes to immersible transducers.

Step	Action
1	If installing CB-type immersible transducers, prep incoming and outgoing RF cables. (Refer to <i>Preparing an RF Cable</i> .)
2	Refer to the wiring diagram for your installation. Route wires from the immersible transducer and the RF cable into the junction box.
3	Strip all wire ends approximately ½ inch (immersible transducer and RF cable wires).
4	Match the colored wires (that is, red to red or black to black).
5	Insert the matching colored ends into the barrel crimp (Figure 5-2).
6	Crimp the barrel connector with a proper crimping tool.
7	Fill the drilled hole in the insulator block with silicon sealant (RTV 102®).
8	Insert the crimped connector into the hole and push in until seated at the bottom of the hole.
9	Cover the crimp with RTV 102®.

**Figure 5-2 Junction Box Terminal Connections**

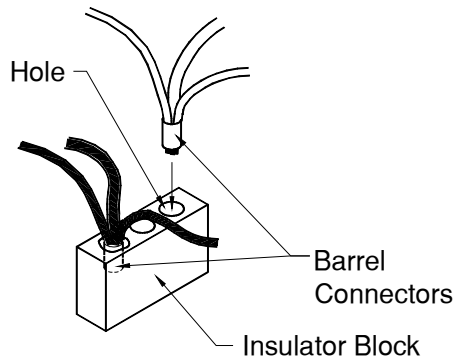



### 5.3.2 Preparing the RF Cable

Preparing the RF cable involves a series of tasks that you must do to install one end of the RF cable into a fitting of a junction box.

#### Preparing an RF Cable (Task 1)

Step	Action
1	Strip end of RF cable 3 inches.
2	Remove outer insulation 3 inches from the end, exposing wire braid.
3	Slip cap and washer over RF cable as shown.

Figure 5-3 Task 1

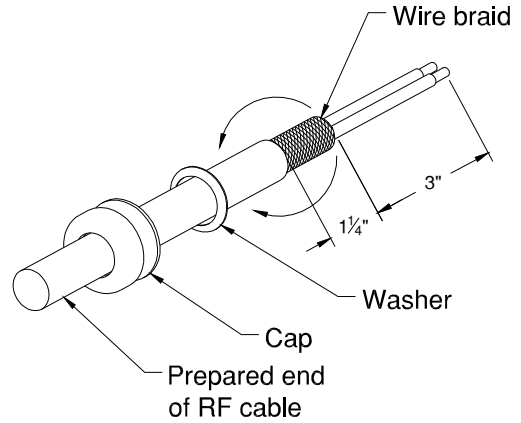

#### Preparing an RF Cable (Task 2)

Step	Action
1	Prepare exposed wire braid, using a common awl, so you can fold the wire braid back.
2	Cut away filler material.
3	Slip rubber grommet over RF cable to point A, as shown.

Figure 5-4 Task 2

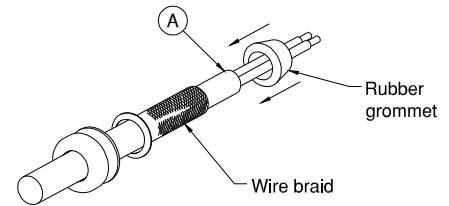

#### Preparing an RF Cable (Task 3)

Fold excess wire braid over the rubber grommet.

Figure 5-5 Task 3

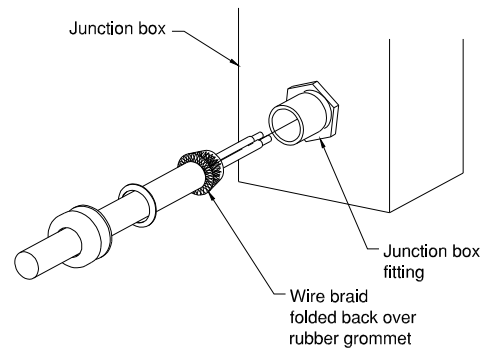
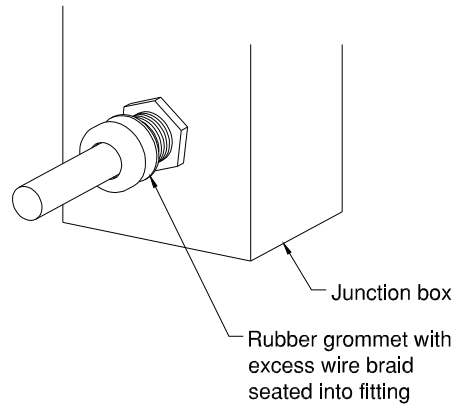

Figure 5-6 Task 4

**Preparing an RF Cable (Task 4)**

Step	Action
1	Bring cap, washer, and rubber grommet together; secure to junction box fitting.
2	Tighten all parts securely.



**5.4 Immersible Installation**

Immersible transducers are compact, hermetically sealed modular components containing either six or twelve elements (Elements operate at one of two frequencies (25 kHz or 40 kHz). Use 40 kHz transducers with 80, 120 and 170 kHz generators.

Installation involves mounting the immersible transducers to the tank walls or on a fixture on the bottom, then wiring them together in parallel using junction boxes.

**5.4.1 Immersible Types**

Immersible transducers are available in four types as follows:

Figure 5-7 Mounting Configurations

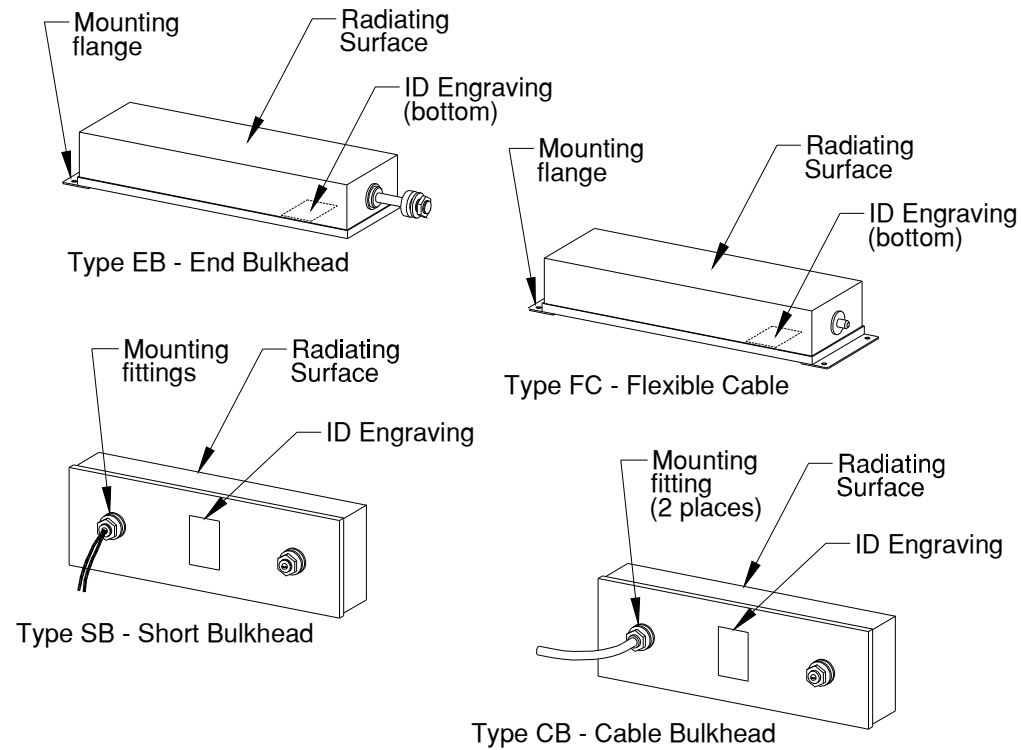

---

## 5.5 Junction Boxes

Junction boxes allow for connecting an array of immersible transducers to the ultrasonic power supply. Figure 5-8 contains illustrations of each junction box style.

Figure 5-8 Junction Boxes

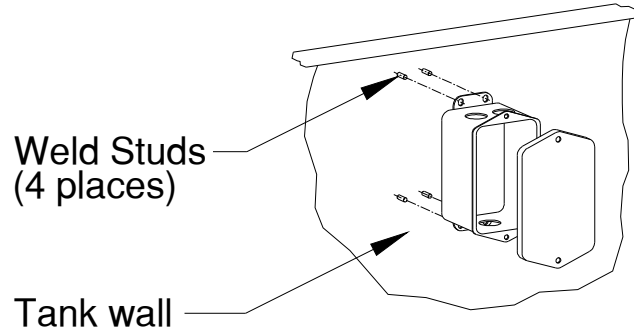

Flange-Mount Junction Box

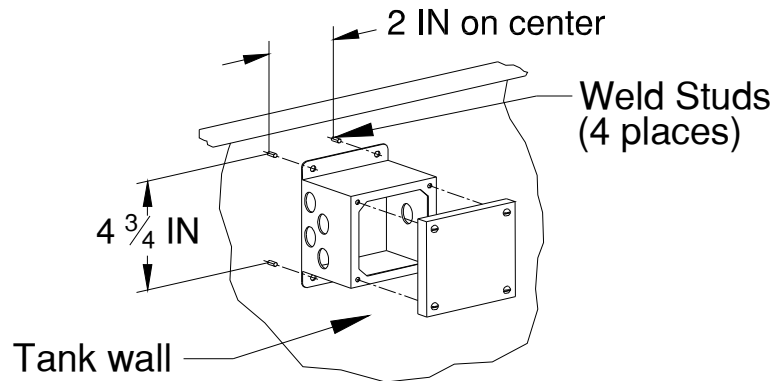

Master Junction Box

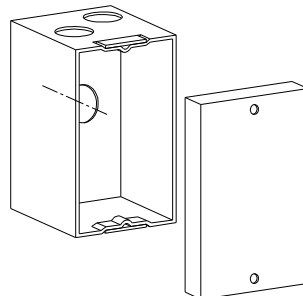

EB/SB-Type Junction Box

Refer to *Configuration Diagrams* which outline how the three styles of junction boxes are used.

---

## 5.6 Mounting Junction Boxes

FC-type and CB-type immersible transducers connect to the ultrasonic power supply through a flange-mount junction box that contains mounting flanges on the bottom. Mount this junction box on the outside of the tank wall or cleaning system framework near the immersible transducer.

If installing one or two FC- or CB-type immersible transducers, install a flange mount junction box by following these steps:

Step	Action
1	Select a location for the flange-mount junction box on the outwall of the tank or framework.
2	If installing, measure and mark the four places for weld studs (Figure 5-8)
3	If installing on framework, drill 4 holes 3/16 inches in diameter. If installing on a tank, use #10-32 weld studs.
4	Mount and secure the junction box.

You use a master junction for connecting of three and four immersible transducers. Mount a master junction box by following these steps:

Step	Action
1	Select a location for the master junction box.
2	Measure and mark the four places for mounting the junction box (Figure 5-8).
3	If installing on a tank wall, install weld studs – <b>Never drill holes in a tank</b> . If installing on another surface, drill four holes 3/16 inches in diameter.
4	Mount the master junction box to the tank or surface.

If mounting EB or SB immersible transducers, refer to the mounting instructions for EB or SB immersible transducers.

## 5.7 Configuration Diagrams

### 5.7.1 12 Element Generators

The following diagrams outline immersible transducer configurations for each ultrasonic power supply.

Figure 5-9 Immersible Transducer Configurations 12 Elements

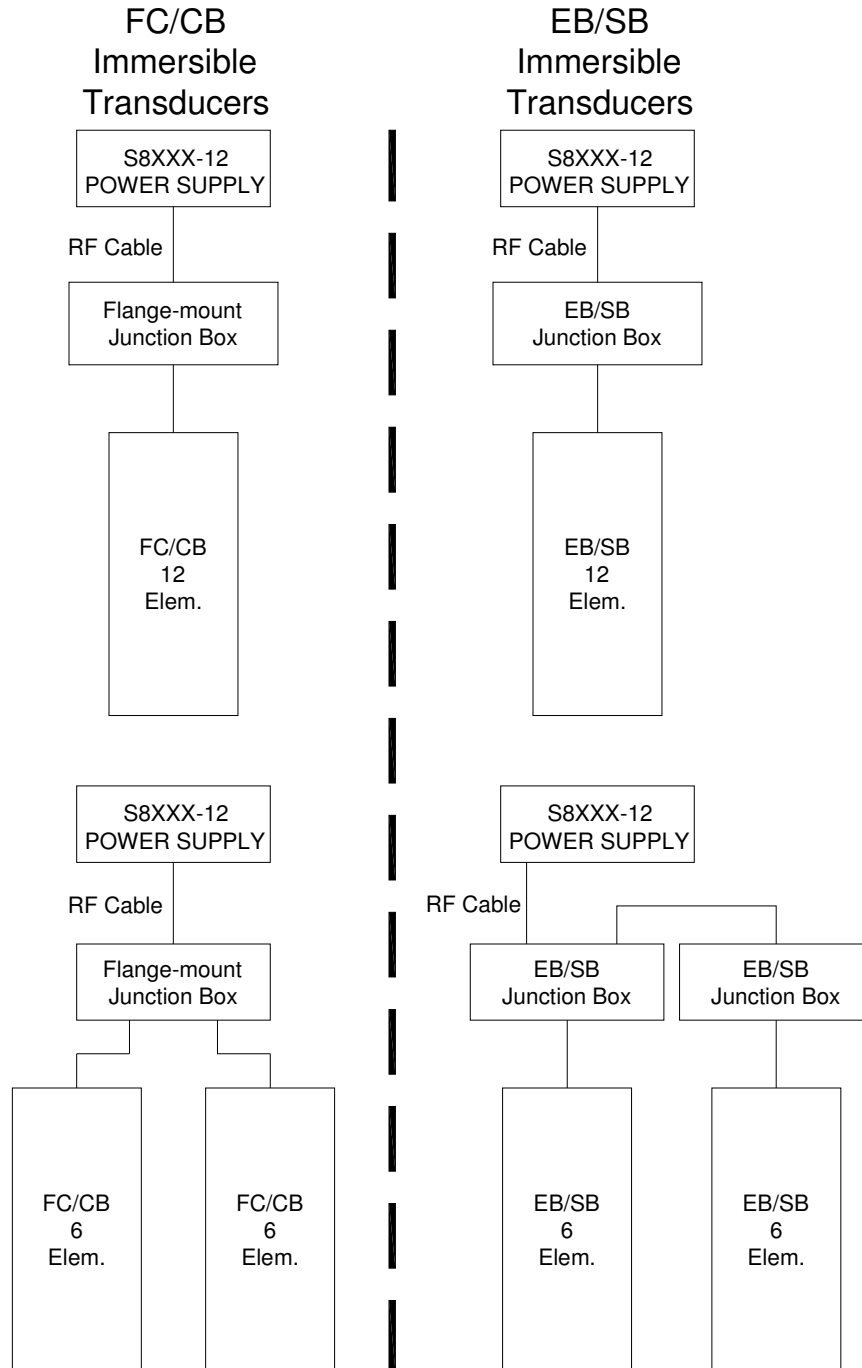

5.7.2 18 Element Generators

Figure 5-10 Immersible Transducer Configurations 18 Elements

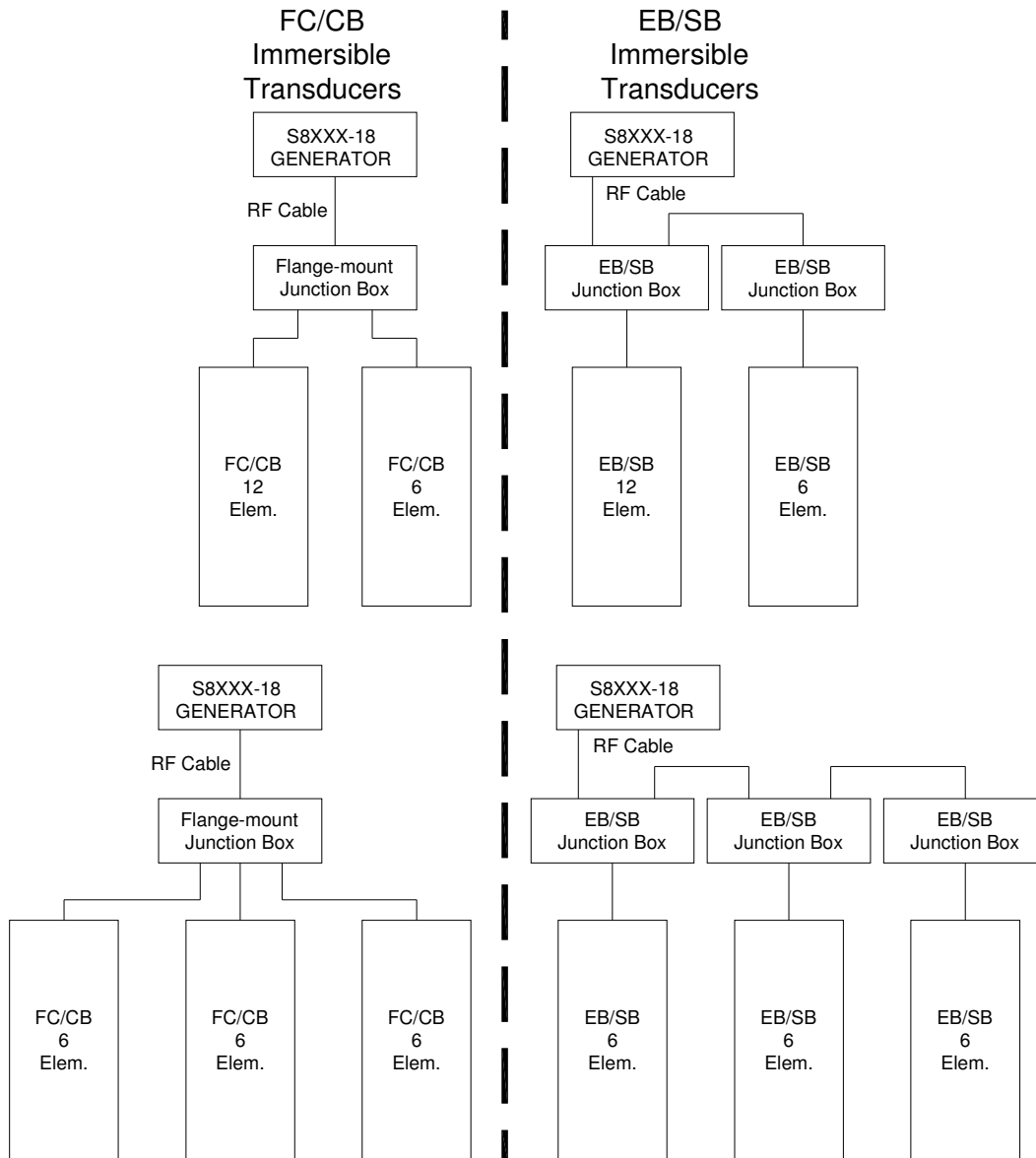

5.7.3 24 Element generators

Figure 5-11 Immersible Transducer Configurations 24 Elements

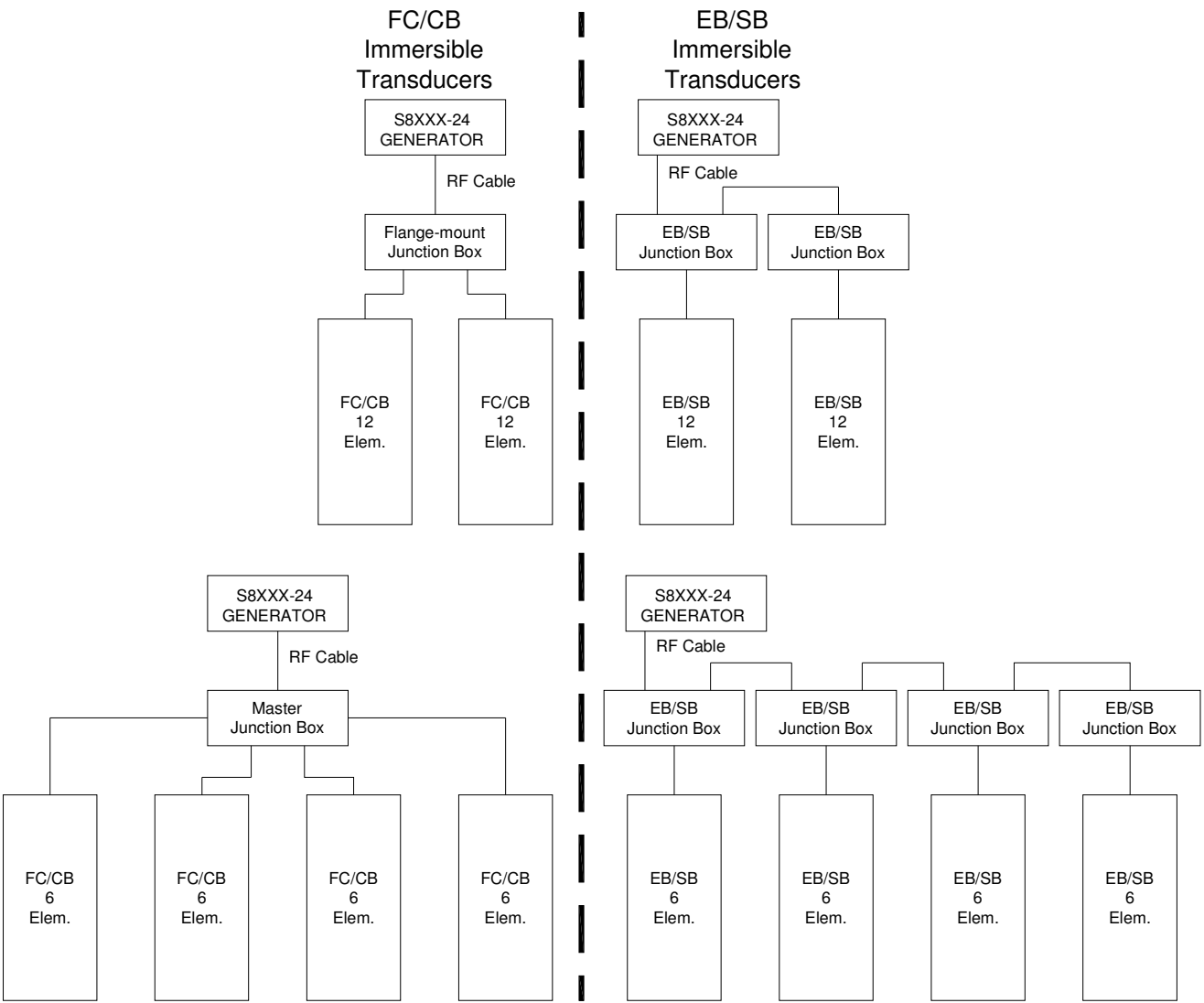

5.7.4 36 Element Generators

Figure 5-12 Immersible Transducer Configurations 36 Elements

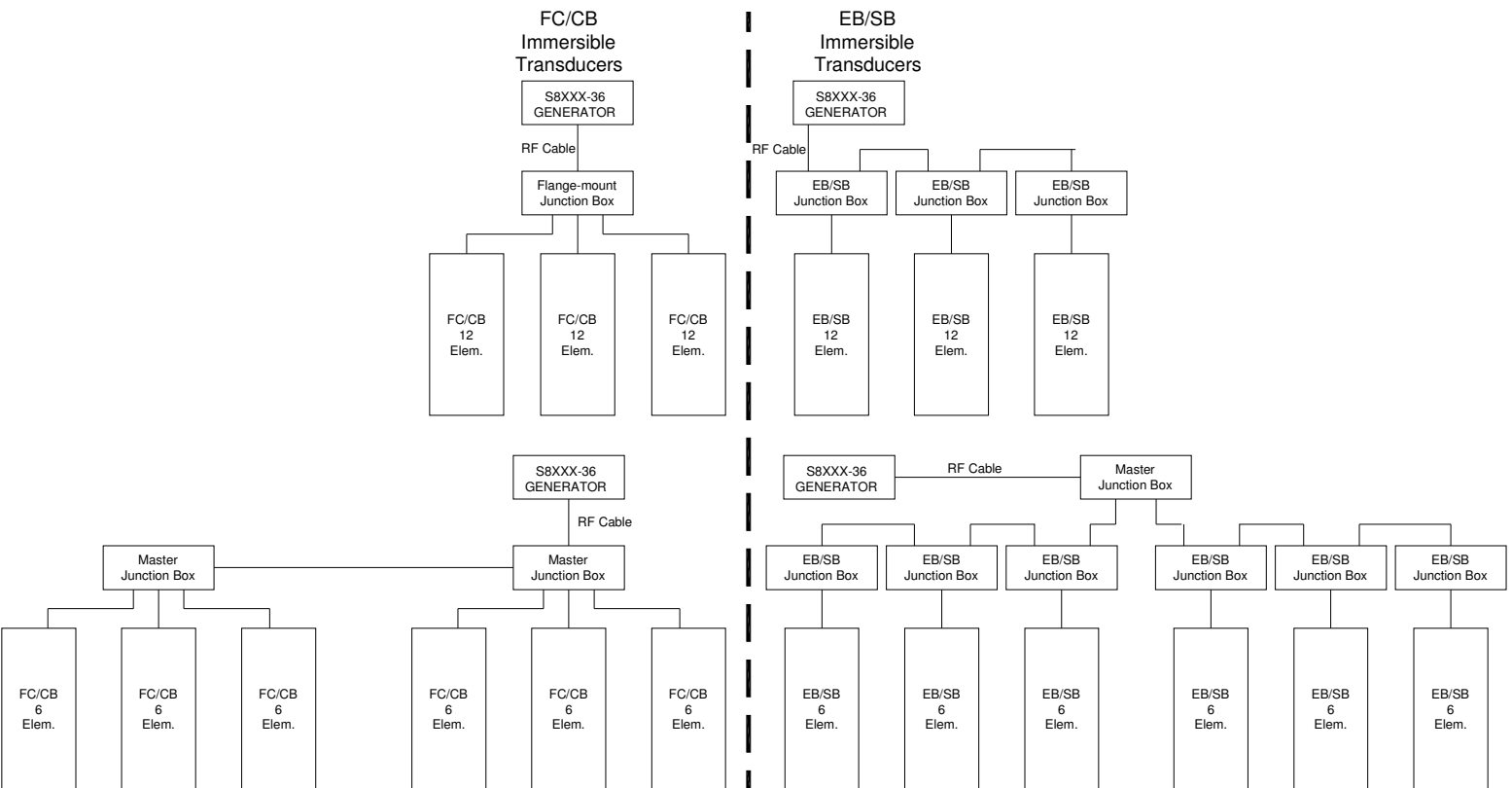
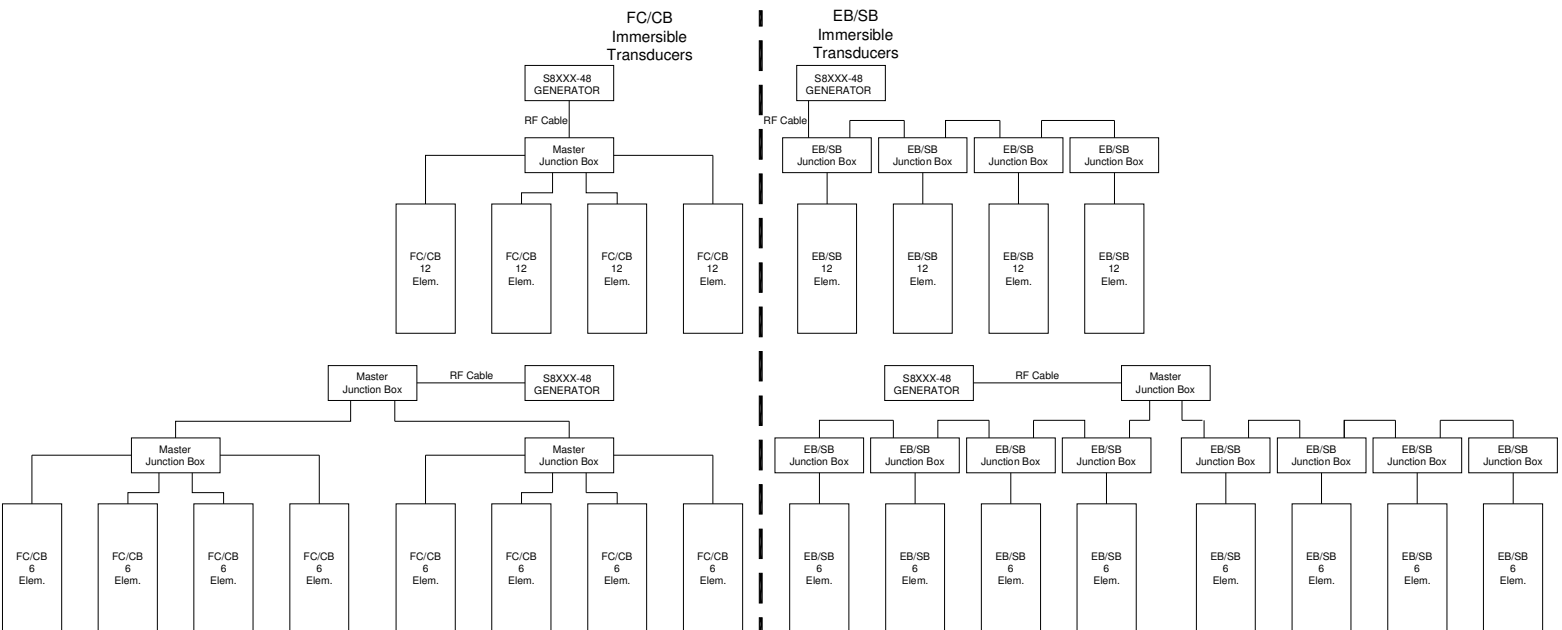



Figure 5-13 Immersible Transducer Configurations 48 Elements



## 5.8 FC-Type Immersible Transducer Installation

FC-type immersible transducers mount on the inside sidewall of a custom ultrasonic tank. An FC-type immersible transducer requires a flexible, water-proof cable (FC) for connections because the cable contacts the water in the tank.

### 5.8.1 FC Immersible Models and Dimensions

Table 6 FC Transducer Models

Model	Chrome	Bright Annealed
FC610-25-6	101-910-672	101-910-691
FC618-25-12	101-910-674	101-910-689
FC610-40-6	101-910-673	101-910-690
FC618-40-12	101-910-675	101-910-688

Figure 5-14 FC610/FC618 Mounting Dimensions

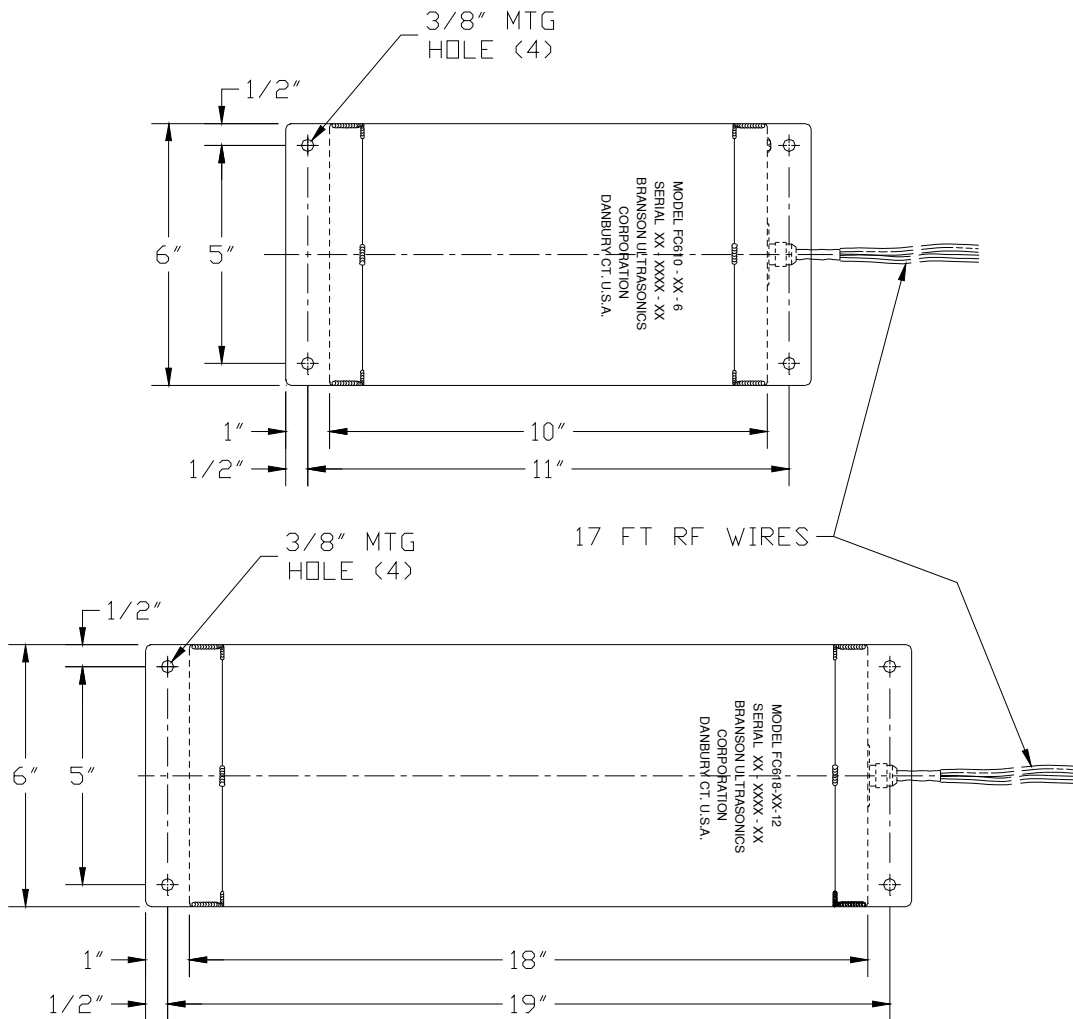

---

## 5.8.2 Mounting an FC-Type Immersible Transducer

Figure 5-15 Mounting FC Type Immersibles

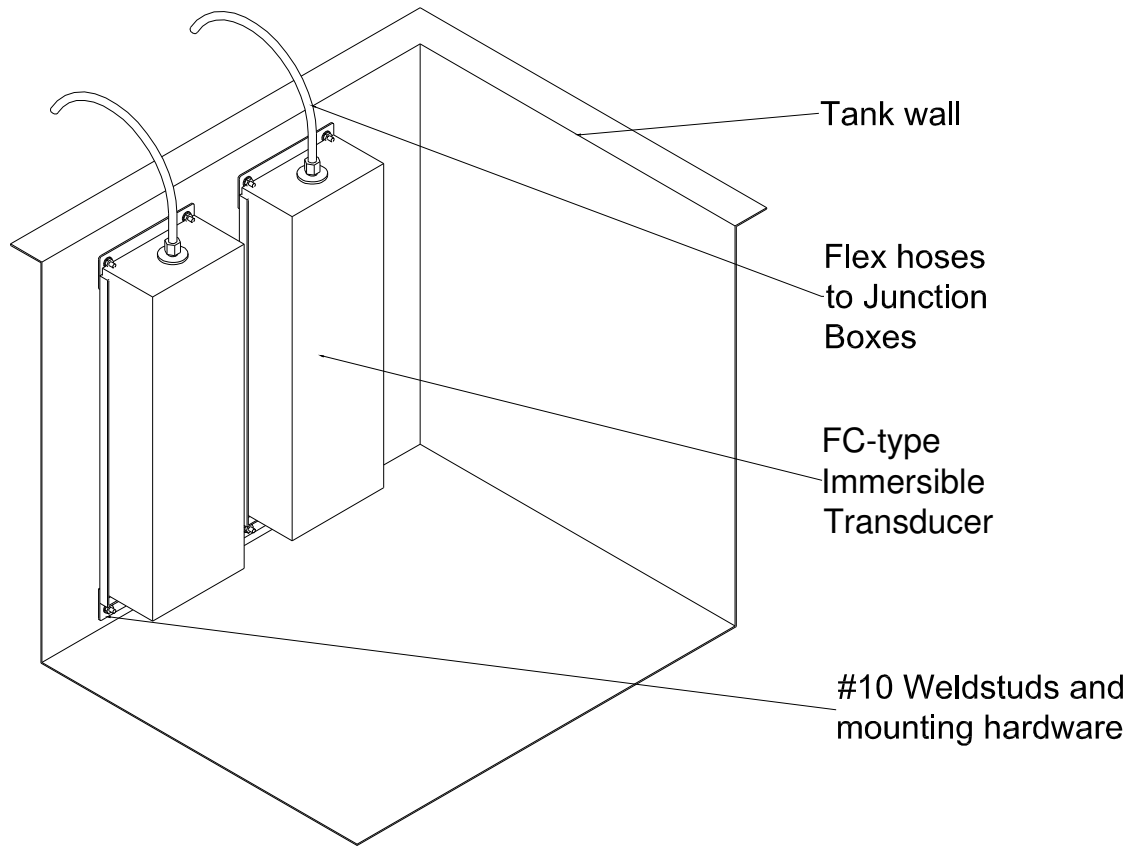

To mount an FC-type immersible transducer directly on a tank wall, follow these steps:

Step	Action
1	Select a location for the immersible transducer.
2	Measure, mark, and install four weld studs using the dimensions in Figure 5-10.
3	Position the immersible transducers over the weld studs through the flange holes.
4	Route the flexible cable to the corresponding junction box.

### 5.8.3 Mounting FC Junction Boxes

Figure 5-12 contains an illustration shows two FC-type immersible transducers mounted on a stainless steel rack and connected to junction boxes.

**Figure 5-16 FC Type Immersible Transducer Junction Box Mounting**

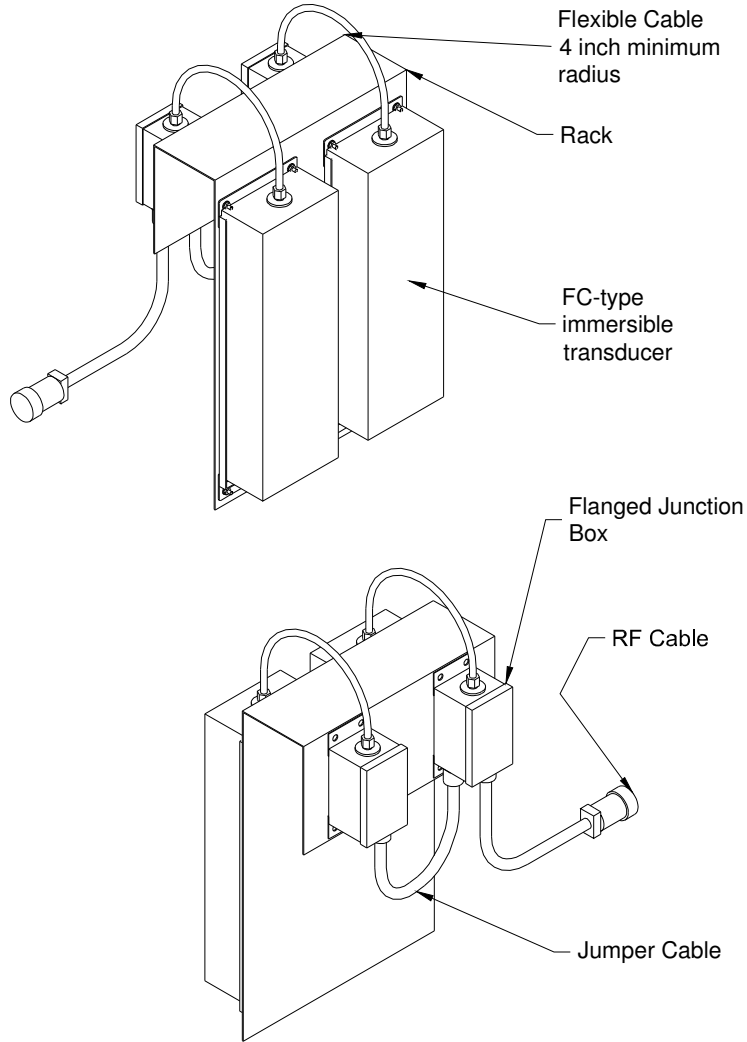

**Note:** You can also wire the two immersible transducers into one junction box. (Refer to *Configuration Diagrams*).

Step	Action
1	Select a location for the immersible transducer. (Refer to <i>Installation Do's and Don'ts</i> ).
2	Measure and mark the four places for installing weld studs.
3	Mount the immersible transducer to the tank or rack.
4	Route the flexible cable to the corresponding junction box. Note: The min. bend radius of the flexible cable is 4 inches in diameter.

## 5.8.4 Wiring One FC Immersible Transducer (12-elements shown)

Figure 5-17 Wiring One FC Type Immersible Transducer

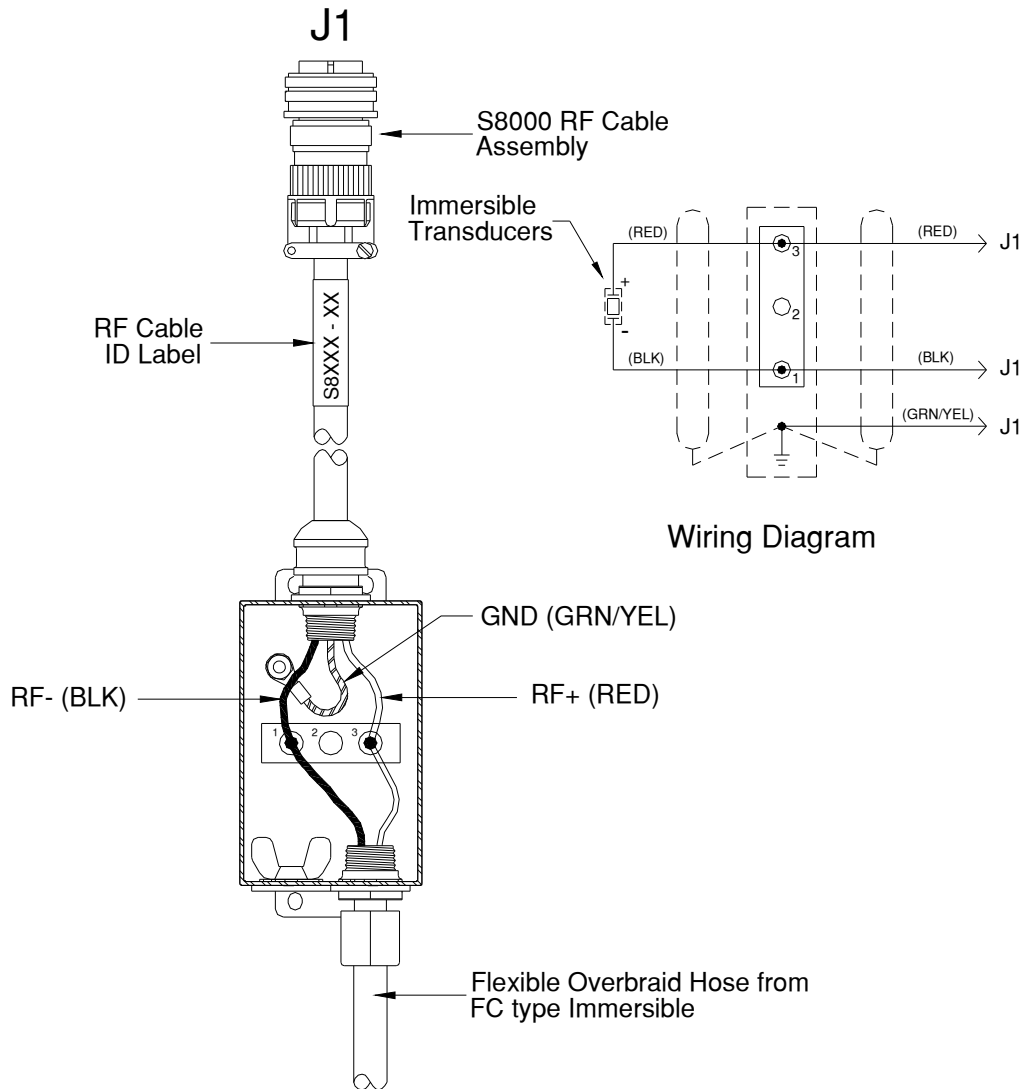

**Note:** After installing, test grounds and continuity according to local codes.

5.8.5 Wiring Two FC Immersible Transducers (24 elements shown)

Figure 5-18 Wiring Two FC Type Immersible Transducers

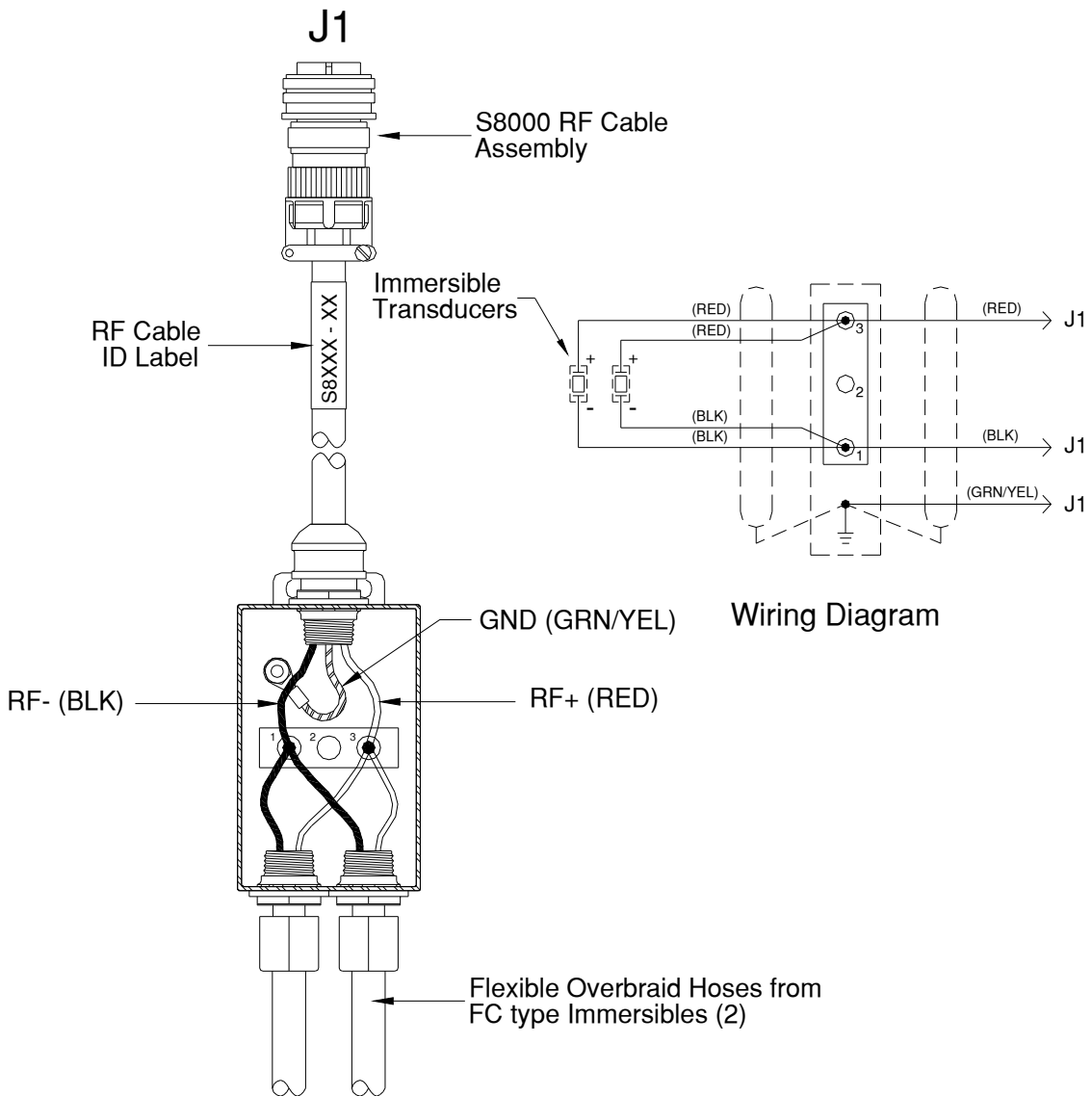

**Note:** After installing, test grounds and continuity according to local codes.

5.8.6 Wiring Three FC Immersible Transducers (36 elements shown)

Figure 5-19 Wiring Three FC Type Immersible Transducers

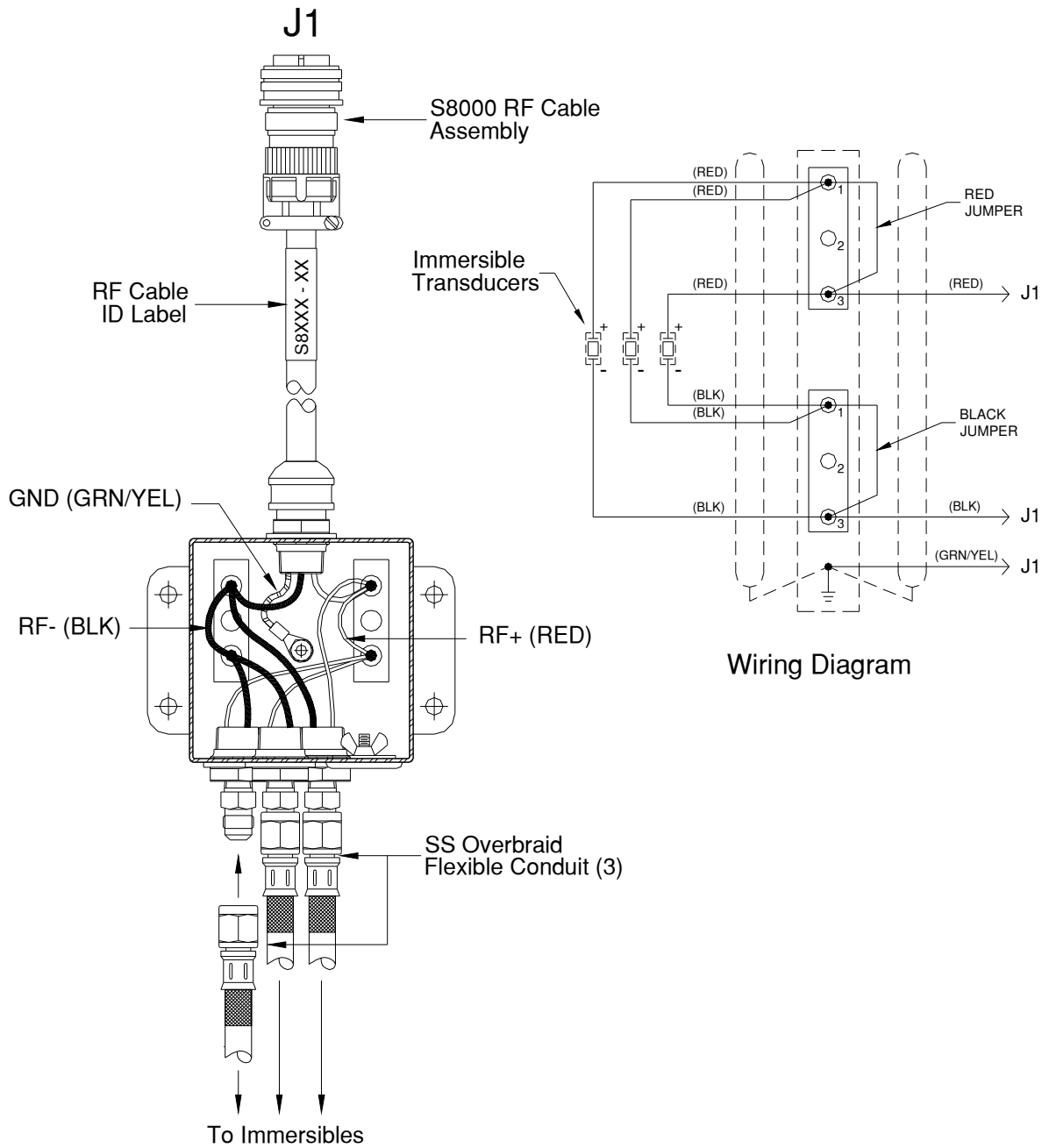

**Note:** After installing, test grounds and continuity according to local codes.

## 5.8.7 Wiring Four FC Immersible Transducers (48 elements shown)

Figure 5-20 Wiring Four FC Type Immersible Transducers

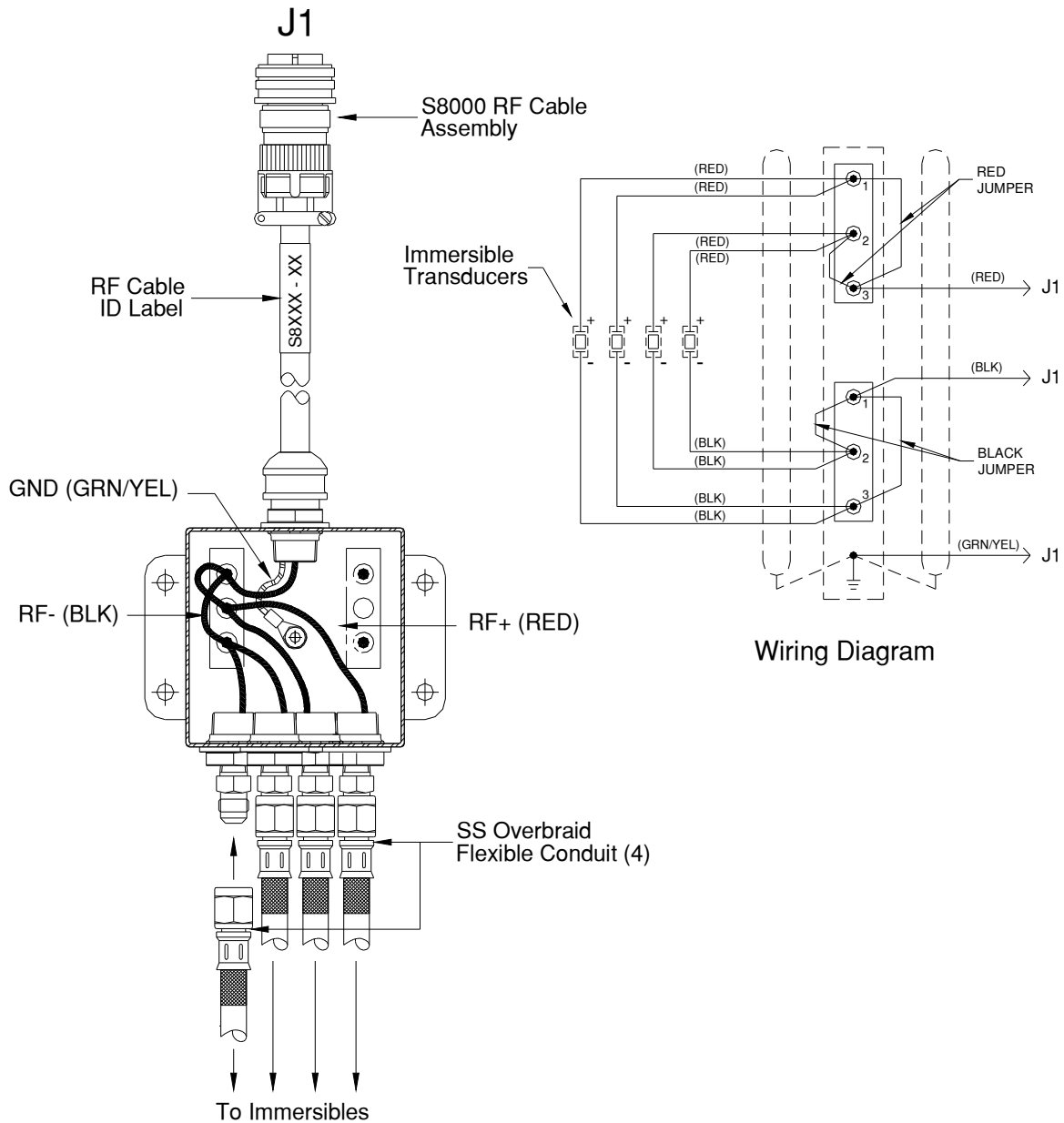

**Note:** After installing, test grounds and continuity according to local codes.



## 5.9 CB Type Immersible Mounting and Wiring

CB type immersible transducers mount on the inside wall of a custom ultrasonic tank.

### 5.9.1 CB Type Immersible Transducer Models and Dimensions

Table 7 CB Type Immersibles

Model	Chrome	Bright Annealed
CB610-25-6	101-910-684	101-910-703
CB618-25-12	101-910-686	101-910-701
CB610-40-6	101-910-685	101-910-702
CB618-40-12	101-910-687	101-910-700

Figure 5-21 CB Type Immersible Transducer Dimensions

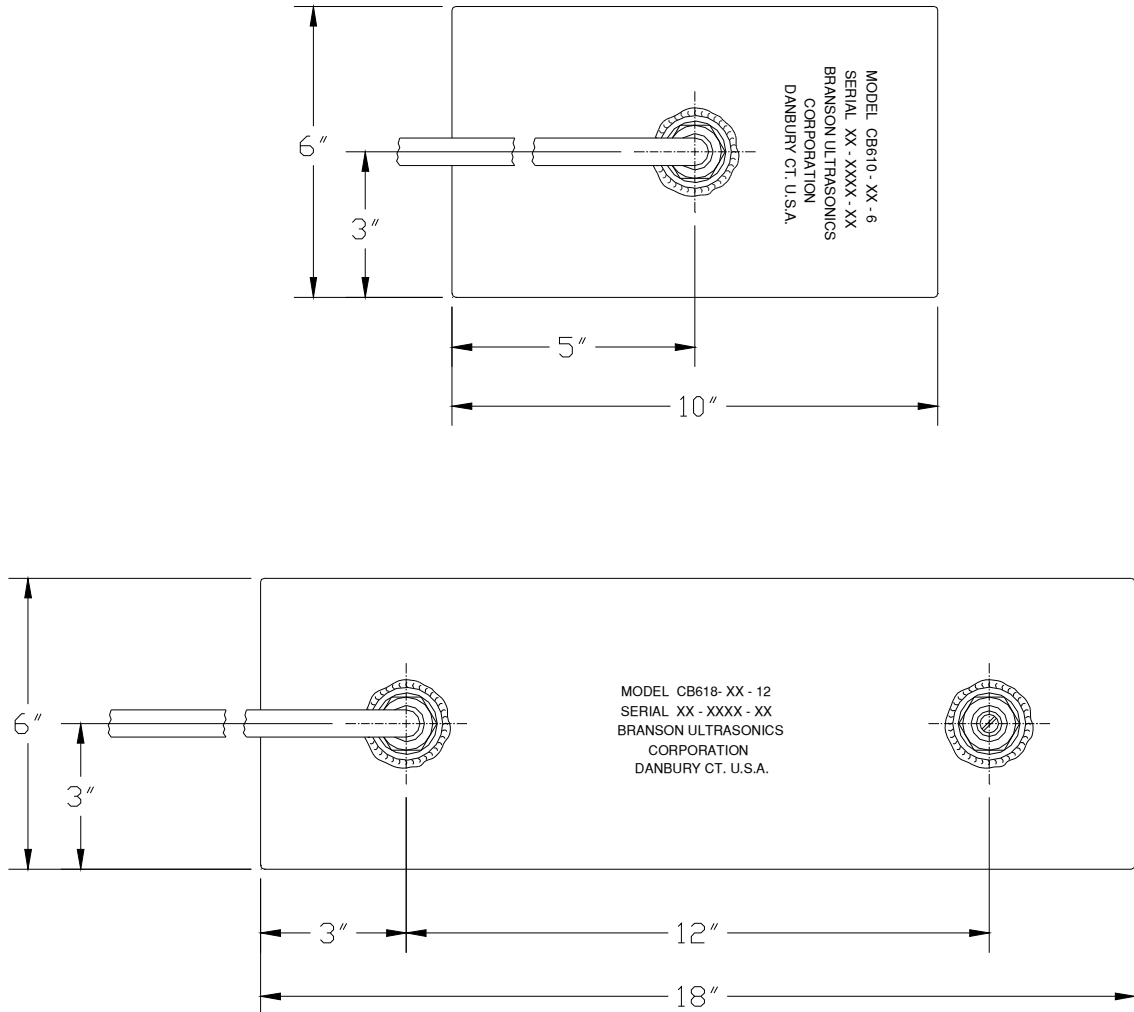

## 5.9.2 Mounting a CB-Type Immersible Transducer

Figure 5-22 Mounting CB Type Immersible Transducers

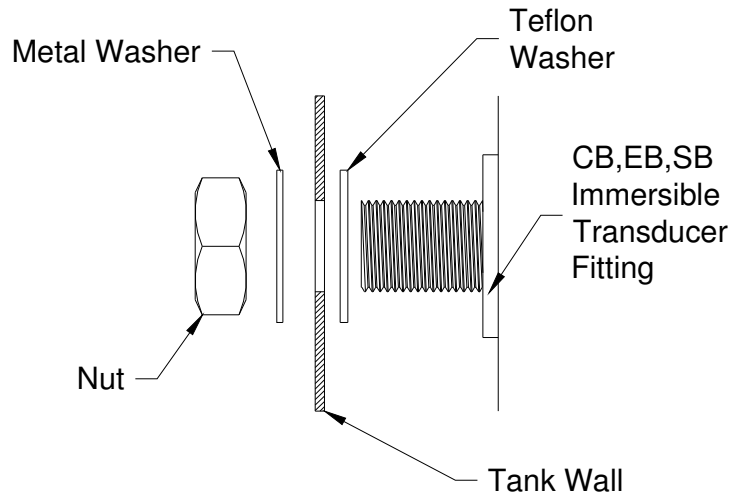

To mount an immersible transducer, follow these steps:

Step	Action
1	Select a location for the immersible transducer (Refer to <i>Do's and Don'ts</i> ).
2	Measure and mark two places for the mounting hole(s).
3	Place the Teflon washer on, then put through holes.
4	Place the cable in desired position.
5	Attach the immersible transducer to the tank sidewall as follows: <ol style="list-style-type: none"> <li>1. Insert the two immersible transducer fittings through holes.</li> <li>2. Attach the washer and jam nut to the fittings and tighten until the washer seats.</li> </ol>
6	Route the immersible transducer cable to the junction box (follow wiring instructions) or the ultrasonic power supply.

### 5.9.3 Wiring CB Immersible Transducers

Figure 5-23 Mounting and Wiring CB Type Immersible Transducers

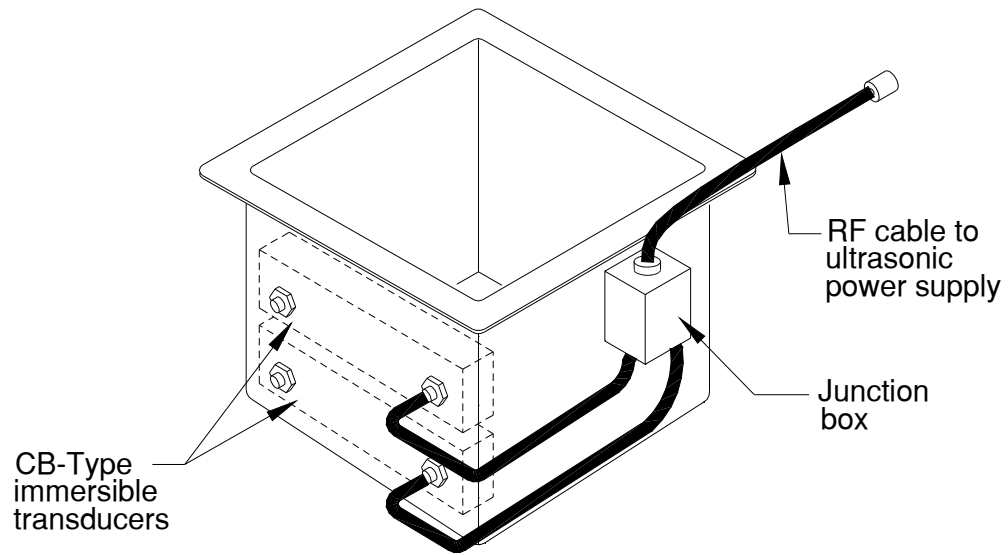

Step	Action
1	Route the RF cable and immersible transducer wire/cables to the junction box.
2	Attach all cables and wires to the junction box.
3	Refer to the wiring illustration and wiring diagram for a 12-element, a 24-element, a 36-element, or a 48-element connection.
4	Follow the instructions in the section Wiring Procedures, located at the front of the Immersible Installation Section.
5	Attach the ground wire to the ground lug.
6	When finished wiring, attach the junction box cover.

## 5.9.4 CB-Type Immersible Transducers – 12-Element

Figure 5-24 Wiring 1 CB Type Immersible Transducer

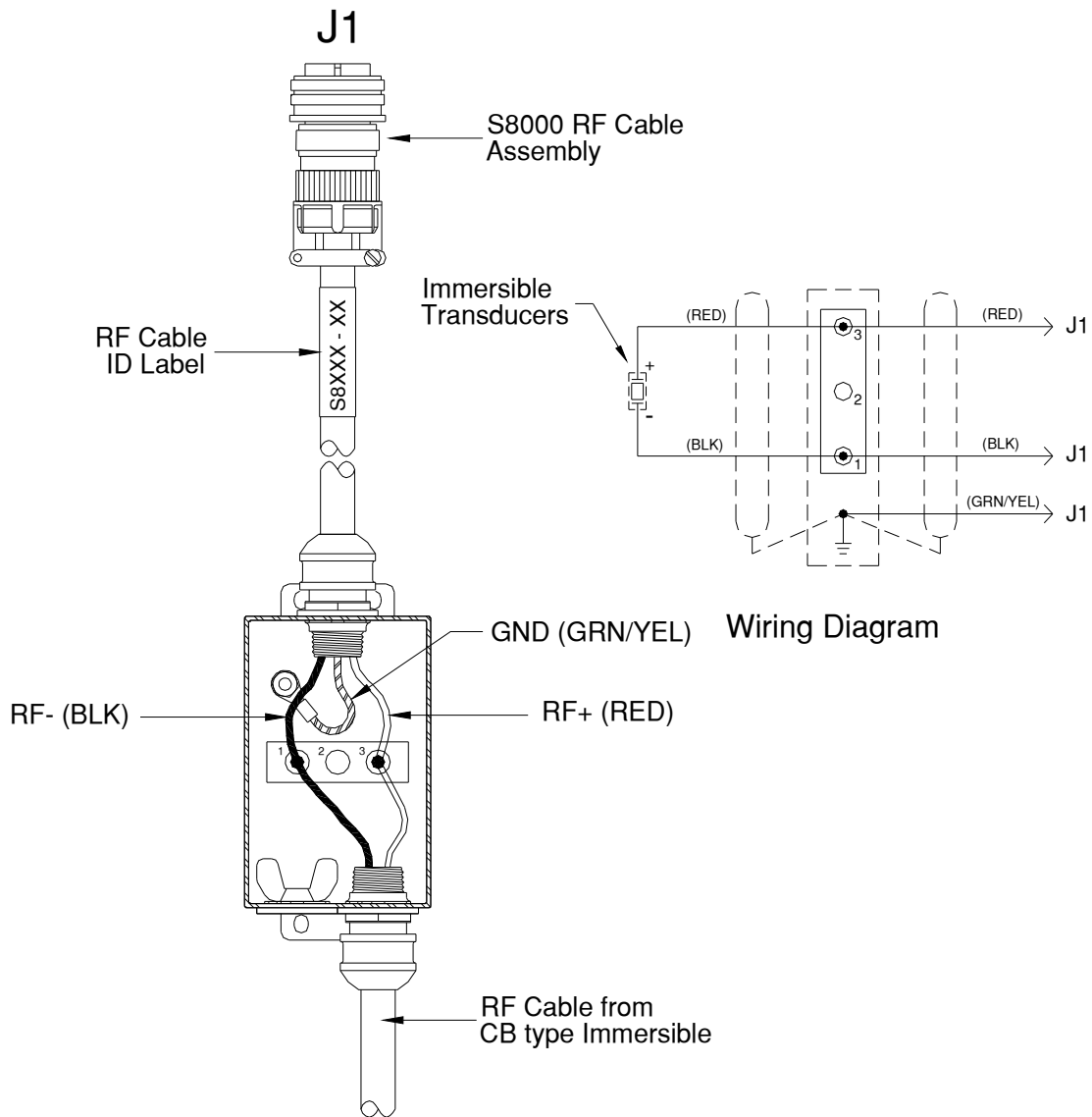

Note: After installing, test grounds and continuity according to local codes.

5.9.5 CB-Type Transducers – 24-Element

Figure 5-25 Wiring 2 CB Type Immersible Transducers

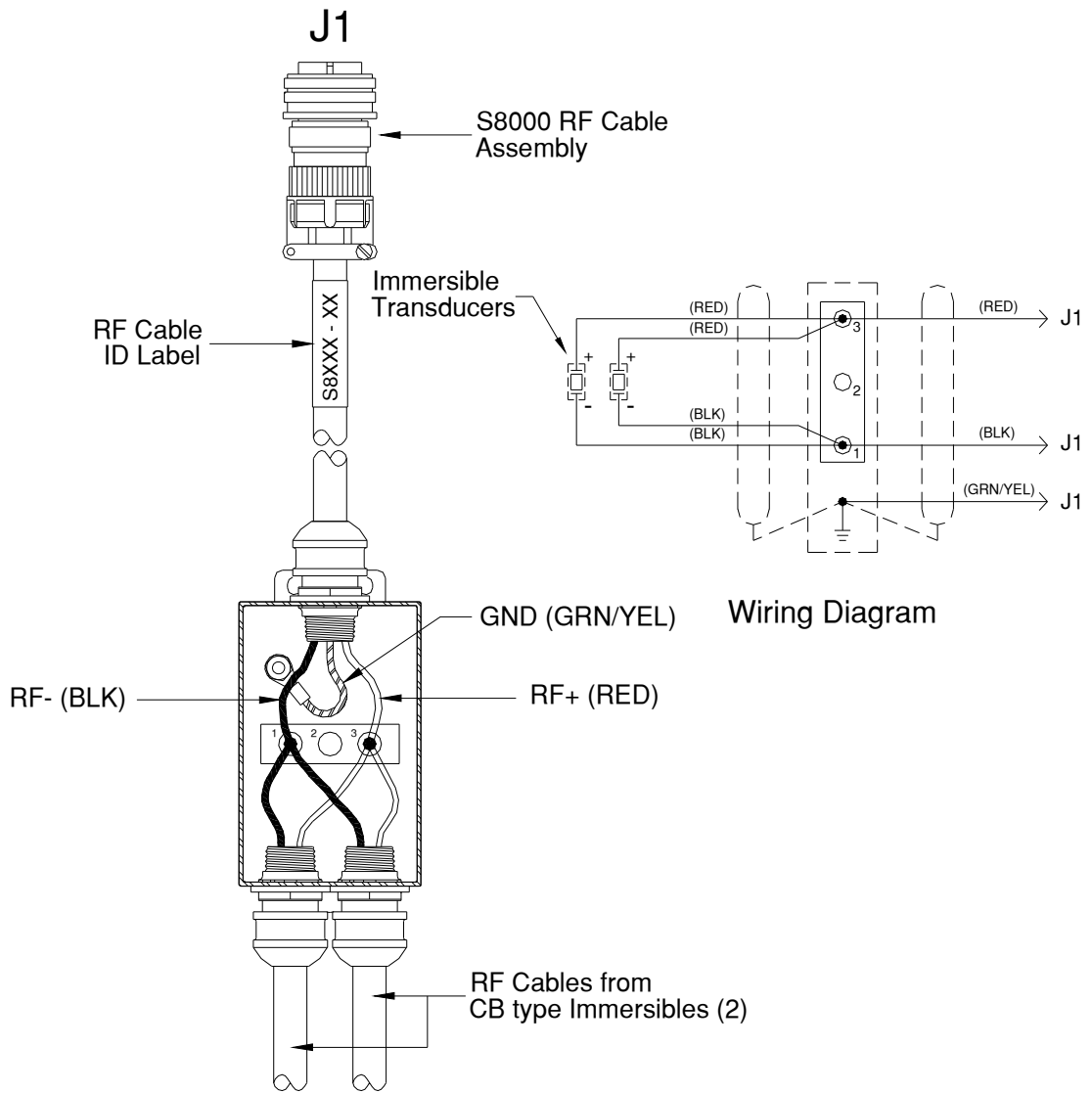

**Note:** After installing, test grounds and continuity according to local codes.

5.9.6 CB-Type Immersible Transducers – 36-Element

Figure 5-26 Wiring 3 CB Type Immersible Transducers

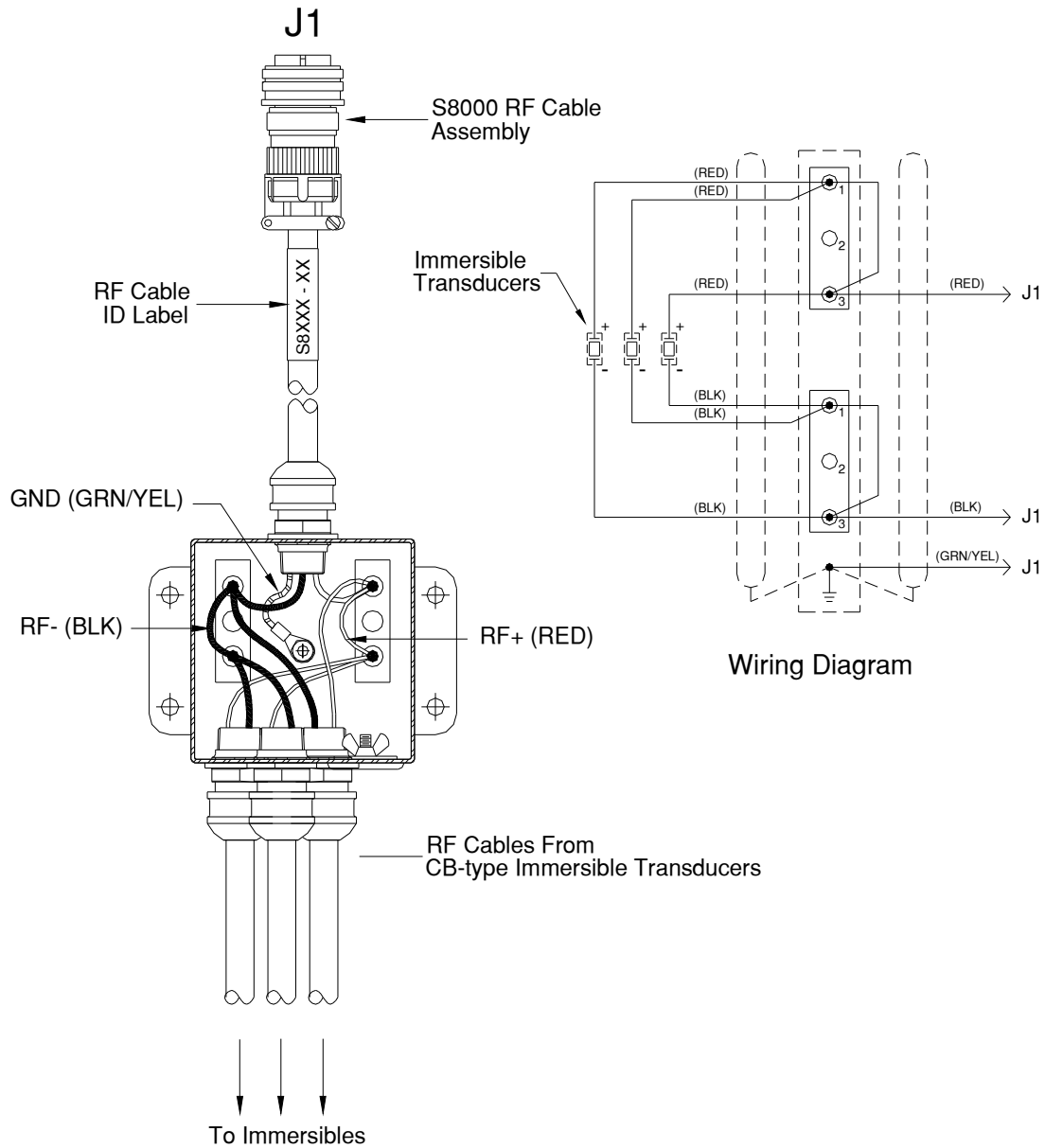

**Note:** After installing, test grounds and continuity according to local codes.

5.9.7 CB-Type Immersible Transducers – 48-Element

Figure 5-27 Wiring 4 CB Type Immersible Transducers

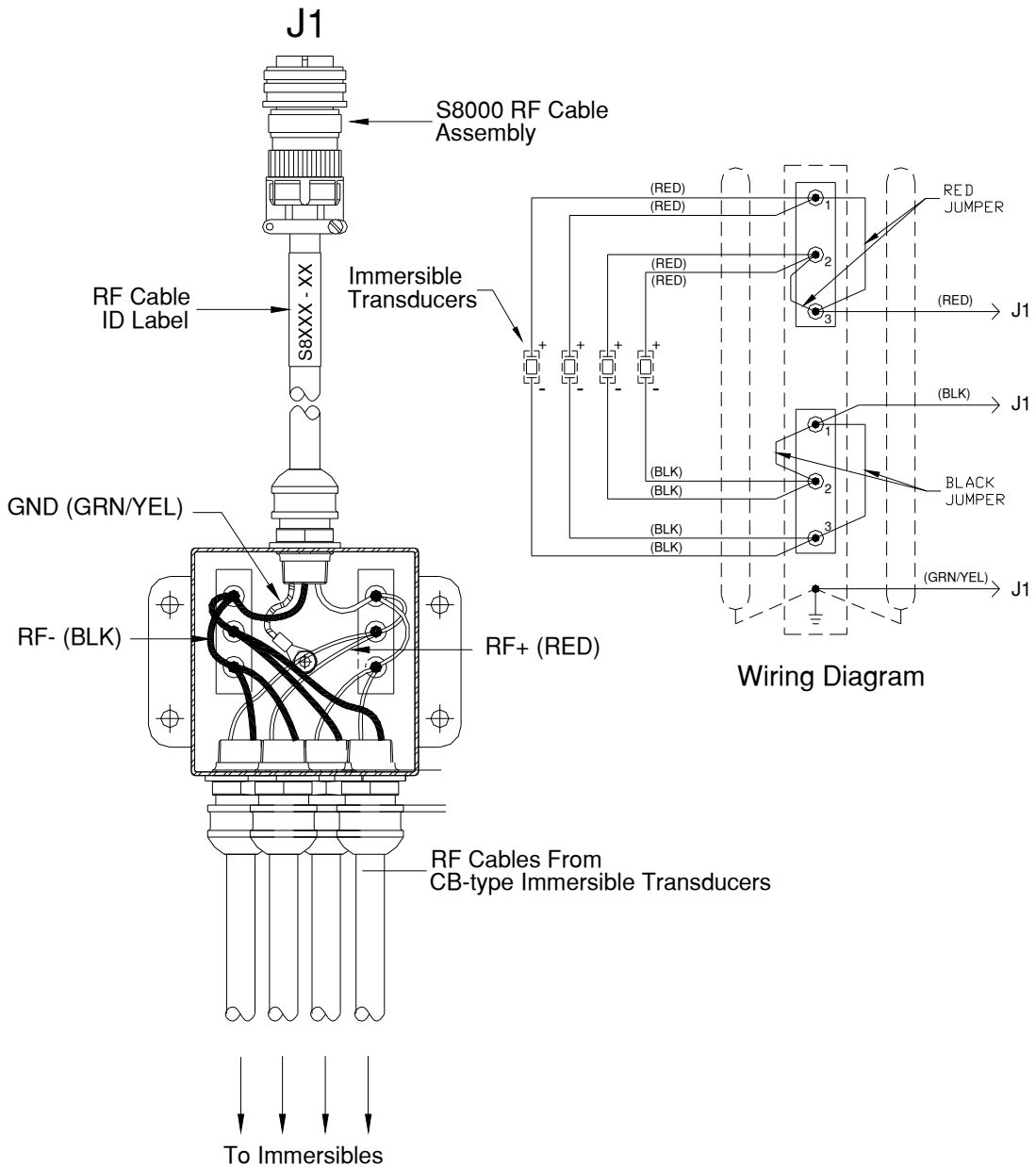

## 5.10 Mounting and Wiring SB-Type Immersible Transducers

### 5.10.1 SB Type Immersible Transducer Models and Dimensions

SB type immersible transducers mount on an inside wall of a custom ultrasonic tank.

Table 8 SB Type Immersibles

Model	Chrome	Bright Annealed
SB610-25-6	101-910-676	101-910-695
SB618-25-12	101-910-678	101-910-693
SB610-40-6	101-910-677	101-910-694
SB618-40-12	101-910-679	101-910-692

Figure 5-28 SB Type Immersible Dimensions

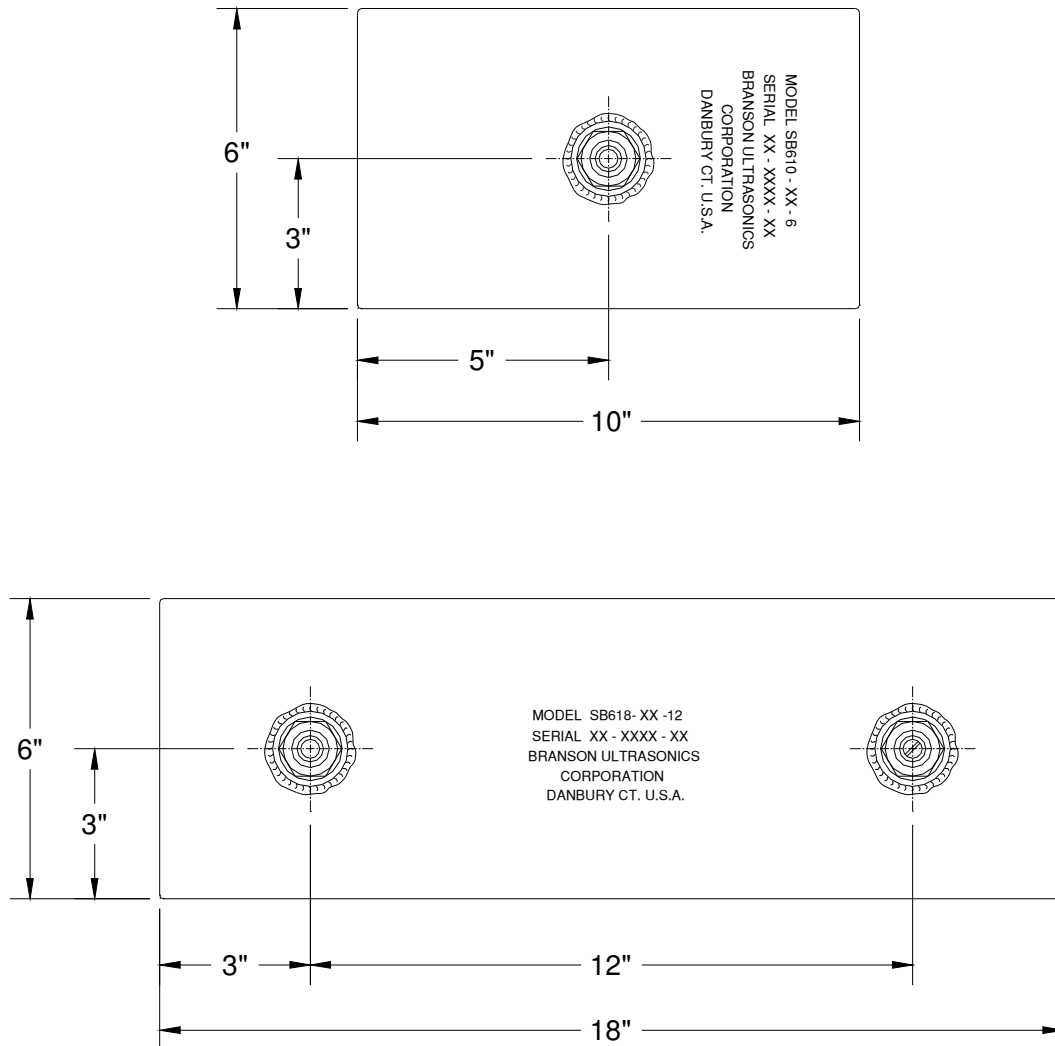



## 5.10.2 Mounting an SB Type Immersible Transducer

Figure 5-29 Mounting an SB Type Immersible Transducer

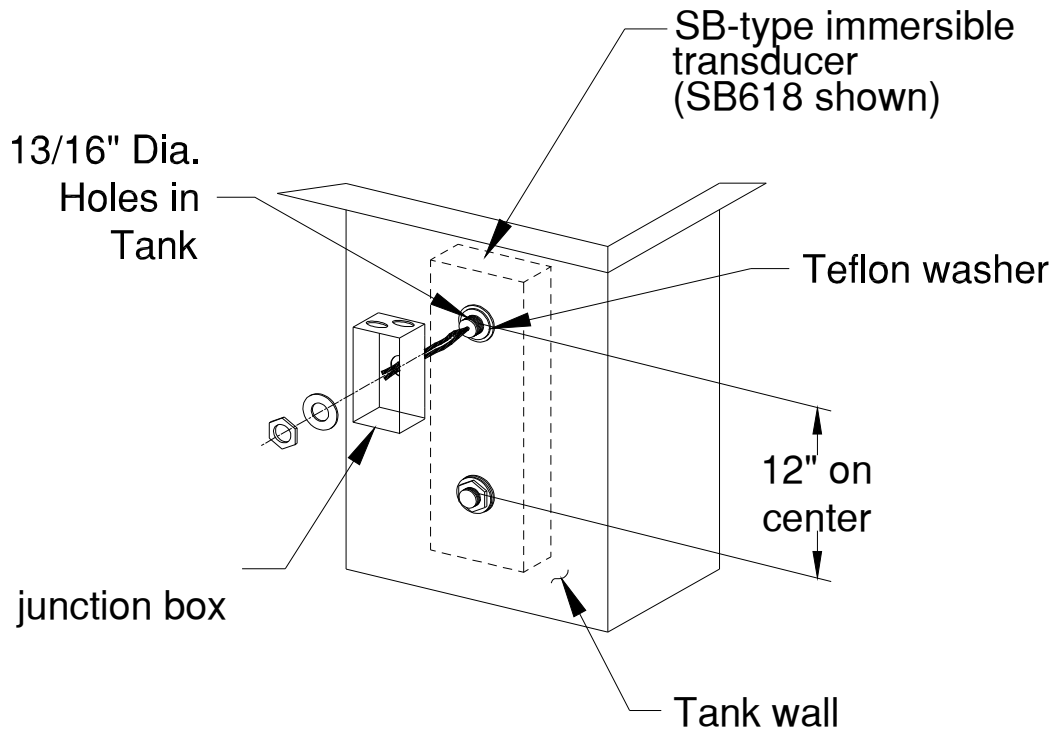

Step	Action
1	Select a location on the tank all for the immersible transducer.
2	Measure and mark the locations for the mounting hole(s) (Figure 5-28 and Figure 5-29)
3	Secure the immersible transducer to the tank wall (as shown in Figure 5-29) as follows: <ul style="list-style-type: none"> <li>a. Attach the washer and jam nut to the fitting and tighten.</li> <li>b. Route the fitting with the wires through the hole in the tank and through the hole of the EB/SB junction box.</li> <li>c. Attach the washer and jam nut to the fitting, and tighten.</li> </ul>
4	Connect the wires to the incoming RF cable or jumper from another immersible transducer. Follow the wiring instructions below.

---

### 5.10.3 Mounting and Wiring SB Type Immersible Transducers

Figure 5-30 Wiring SB Junction Boxes

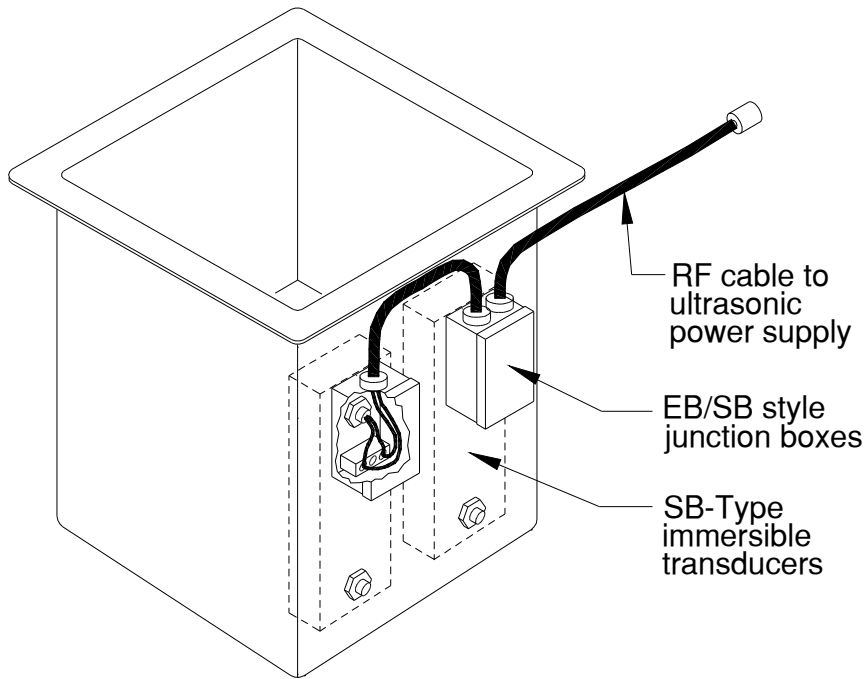

## 5.11 Mounting and Wiring EB-Type Immersible Transducers

### 5.11.1 EB Immersible Transducer Models and Dimensions

SB type immersible transducers mount on the bottom of a custom ultrasonic tank.

Table 9 EB Type Immersibles

Model	Chrome	Bright Annealed
EB610-25-6	101-910-680	101-910-699
EB618-25-12	101-910-682	101-910-696
EB610-40-6	101-910-681	101-910-698
EB618-40-12	101-910-683	101-910-697

Figure 5-31 EB Type Immersible Transducer Dimensions

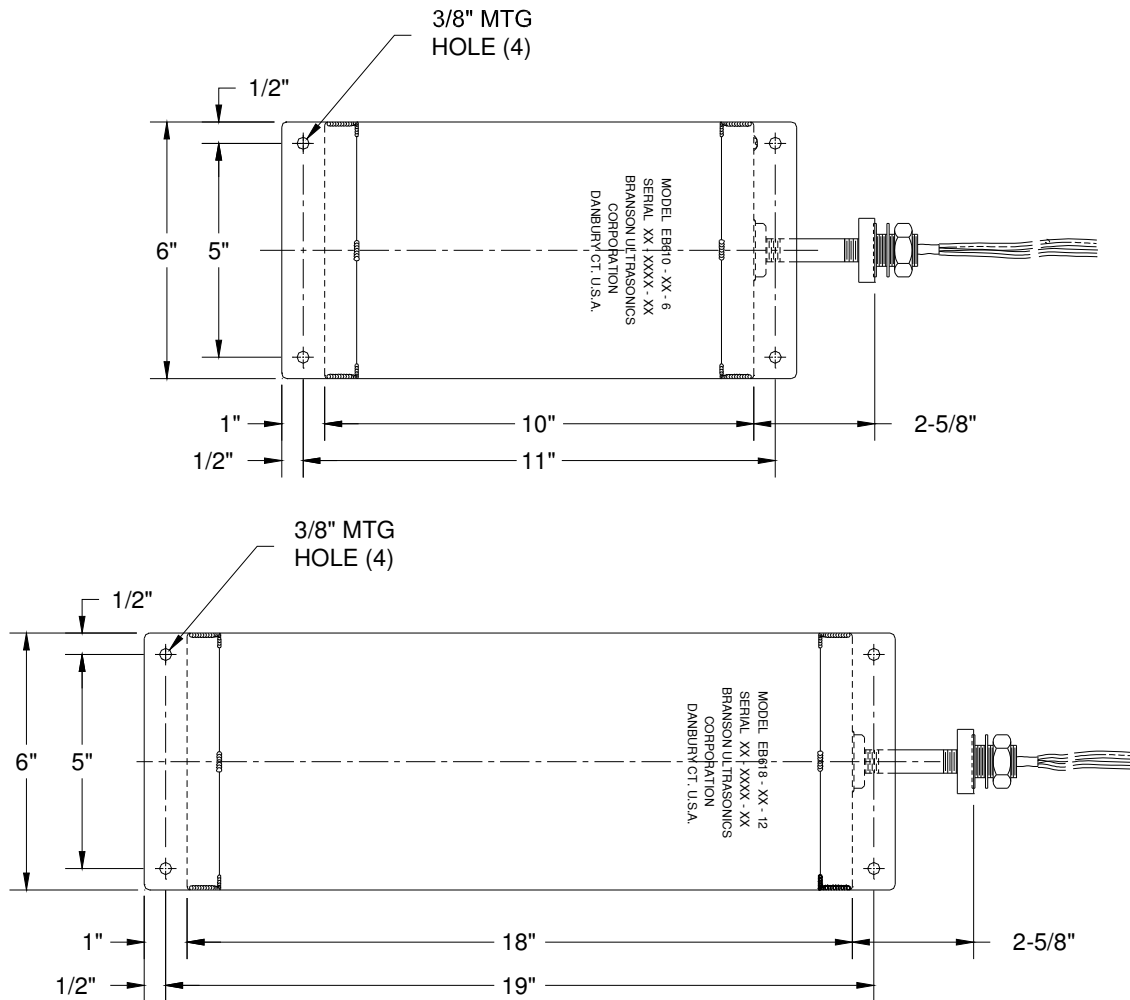

## 5.11.2 Mounting an EB-Type Immersible Transducer

Figure 5-32 Mounting an EB Type Immersible Transducer

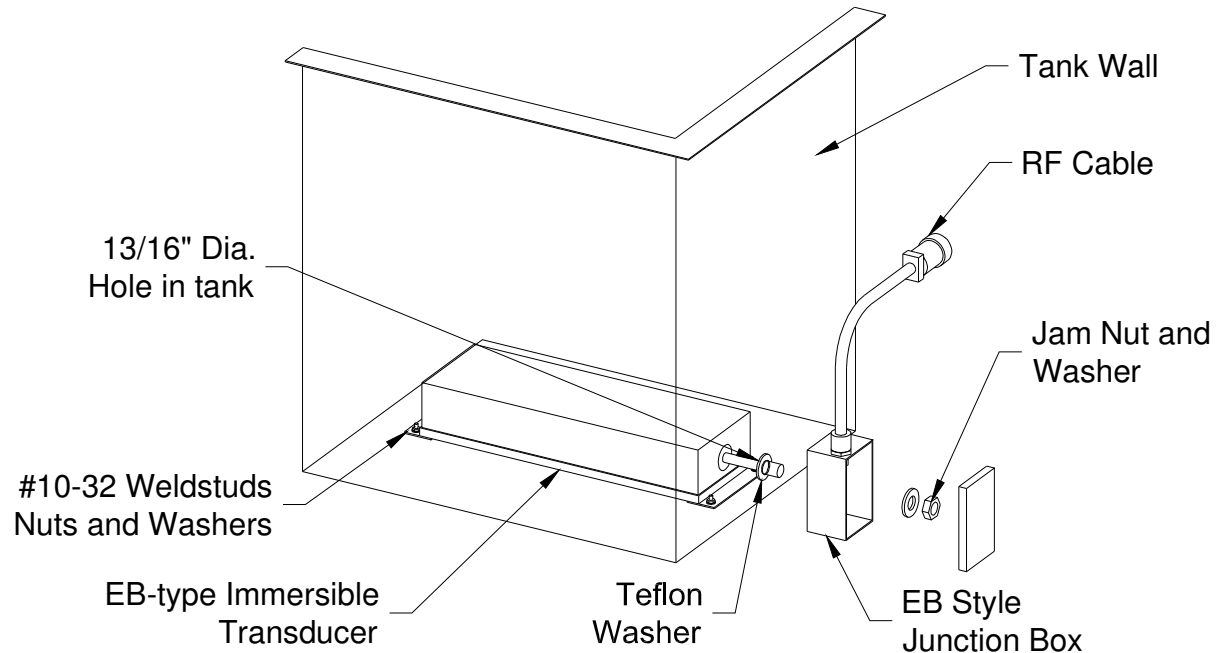

To mount an EB-Type immersible transducer, follow these steps:

Step	Action
1	Select a location on the tank bottom or sidewall for the immersible transducer.
2	Locate and punch or drill the mounting hole
3	Attach the immersible transducer to the tank bottom or sidewall (as shown in Figure 5-32) as follows: <ol style="list-style-type: none"> <li>Attach the washer and jam nut to the fitting and tighten.</li> <li>Route the fitting with the wires through the hole in the back of the EB/SB junction box.</li> <li>Attach the washer and jam nut to the fitting, and tighten.</li> <li>Secure the Immersible to the bottom or wall with weldstuds, nuts and washers.</li> </ol>
4	Connect the wires to the incoming RF cable or jumper from another immersible transducer. Follow the wiring instructions.

### 5.11.3 EB Type Immersible Transducer Junction Box Wiring

Figure 5-33 EB Immersible Transducer Junction Box Wiring

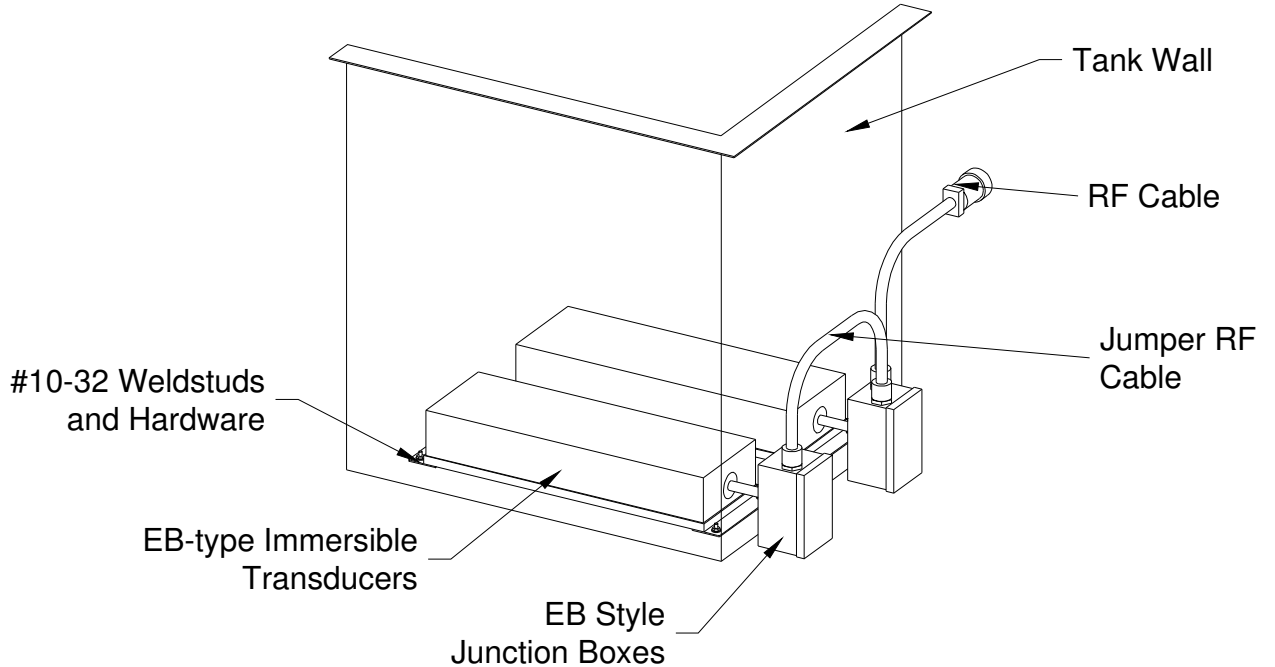

Step	Action
1	Route the RF cable and immersible transducer wire/cables to the EB/SB style junction box.
2	Attach the all cables and wires to the EB/SB style junction box.
3	Refer to the appropriate wiring illustration and wiring diagram for a 1,2,3 or 4 immersible transducers. <b>Caution:</b> Wire all immersible transducers in parallel (red-red; black-black).
4	Follow the instructions in the section <i>Wiring Procedures</i> , located at the front of the Immersible Installation Section.
5	Attach the ground wire to the ground lug.
6	When finished wiring, attach the EB/SB style junction box cover.

### 5.11.4 Wiring One EB/SB-Type Immersible Transducer

Figure 5-34 Wiring 1 EB/SB Type Immersible Transducer

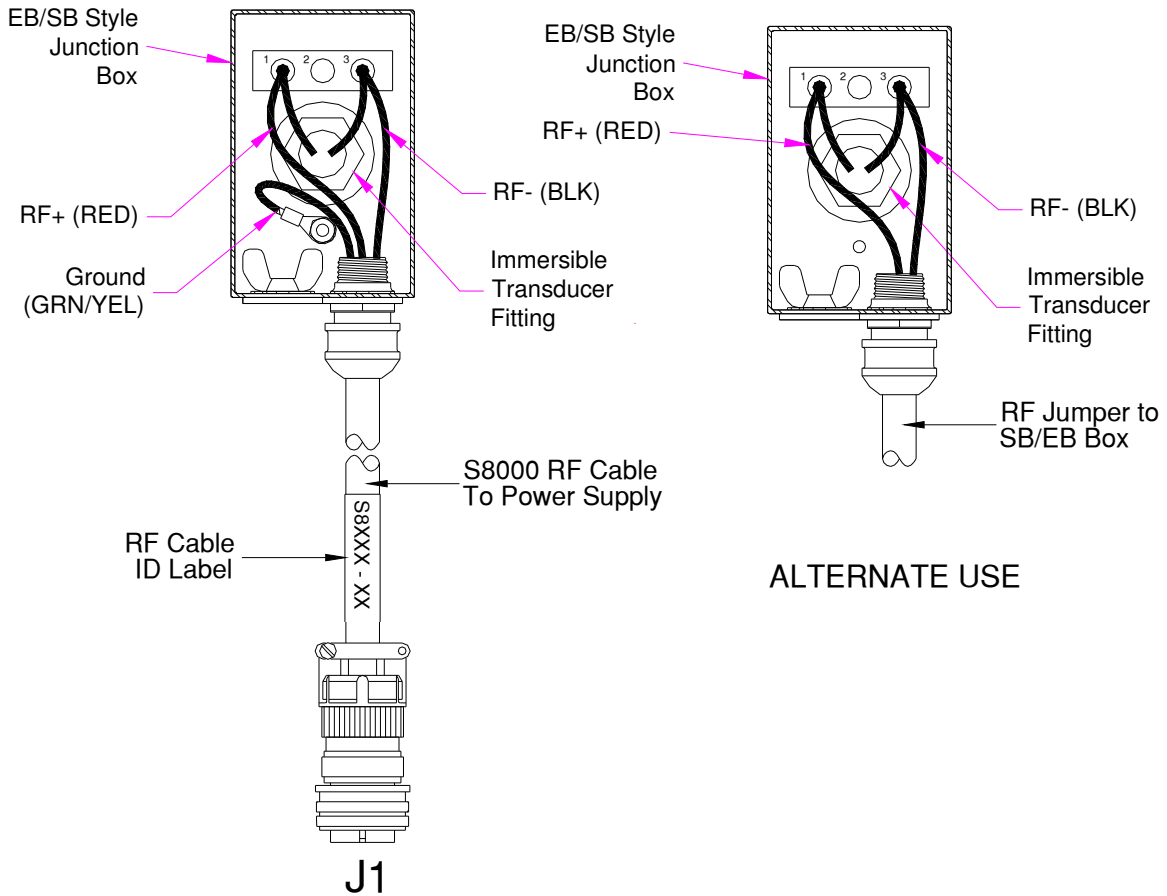

Wiring Diagram

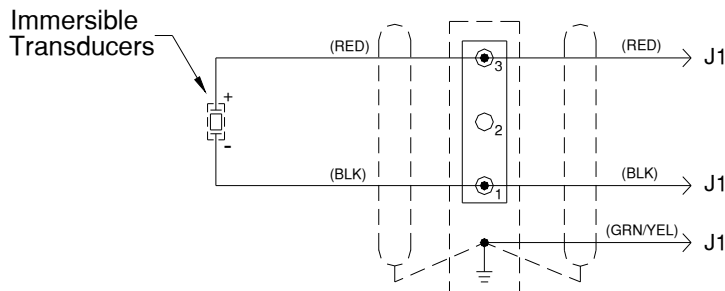

### 5.11.5 Wiring Two Immersible Transducers in Parallel

Figure 5-35 Wiring 2 or More EB/SB Type Immersible Transducers

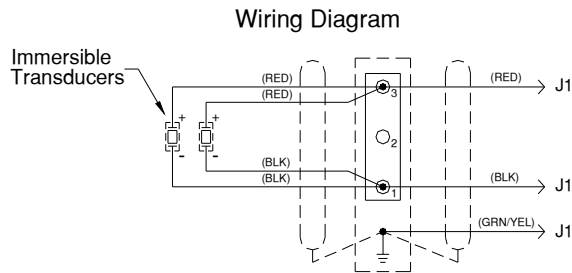
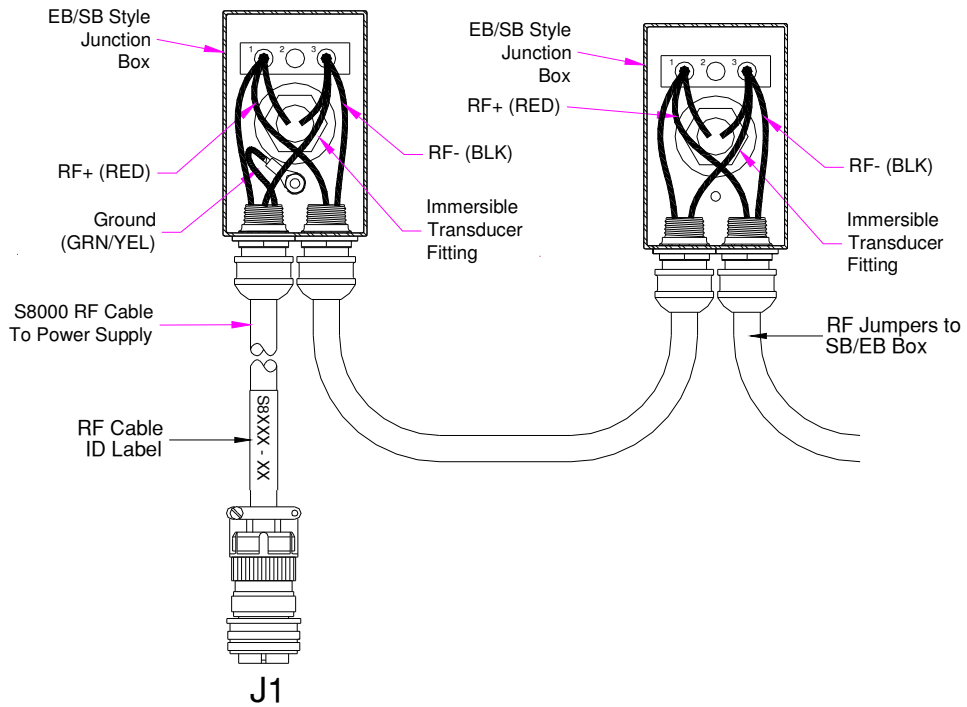





---

# **S83/85 Ultrasonic Generator**

## **A40-064**



---

## 6 Troubleshooting

### Overview

This section contains information for troubleshooting the ultrasonic power supply and includes the following:

- Periodic maintenance – steps for maintaining tanks and immersible transducers.
- Troubleshooting charts – common problems and possible solutions.
- Resistance charts – for isolating defects in the Driver Board.
- Parts list – contains part numbers for replaceable components.

**Warning:** *Ultrasonic Power supplies produce high voltage. Before working on an ultrasonic power supply, do the following (1) turn off the ultrasonic power supply and unplug AC voltage; and (2) remove the cover and allow at least 1 minute for capacitors to discharge.*

### 6.1 Periodic Maintenance

Ultrasonic power supplies, ultrasonic tanks, and immersible transducers require periodic maintenance every 3 months or sooner.

#### 6.1.1 Ultrasonic Power Supplies

Step	Action
1	Unplug the Ultrasonic power supply from the AC voltage source.
2	Remove the cover (Figure A-1).
3	Remove any dirt and dust. (You can use forced dry air, filtered to 5 microns).
4	Replace the cover (Figure A-1).
5	Inspect RF cable and line cord for damage or wear. Replace if damaged.

#### 6.1.2 Tanks and Immersible Transducers

Step	Action
1	Drain the tank as required by your application.
2	Use a non-abrasive cloth to remove contamination from cleaning surfaces or an ultrasonic tank or an immersible transducer. Caution: Take care never to mar or scratch a radiating surface. Doing so can accelerate cavitation erosion.
3	For a tank with the pump and filter option, inspect the filter cartridges and replace when necessary.
4	Inspect the RF cable and line cord (heated units only) for damage. Replace a damaged cable, and damaged line cord, or both.
5	Refill the tank.

## 6.2 Trouble-shooting Charts

Problem	Cause	Solution
Over temp LED on (S8300 and S8500)	Ambient air temp exceeds 105°F.  Air flow to the cooling chamber obstructed.	Move ultrasonic power supply to cooler location.  Remove all obstructions from back of ultrasonic power supply.
Overload LED on (S8500 only)	Incompatible load, power, or frequency connected to ultrasonic power supply.  Faulty connection between ultrasonic power supply and load.  Faulty component connected to ultrasonic power supply.  Low line voltage.	Check model numbers of tanks or immersible transducers connected to ultrasonic power supply. Refer to section 3 of the manual for more information.  Check RF cable and all connecting cables for open or short circuits.  Refer to Section 6.3, troubleshooting the load.  Check that the line voltage is above 190VAC.
Upper Limit or Lower Limit LED on. (S8500 only)	A component connected to the ultrasonic power supply does not have the same power or frequency rating.  Faulty component connected to the ultrasonic power supply.	Check model numbers among ultrasonic power supply and all connected components. Refer to Section 3 of the manual.  Troubleshoot/test tank or immersible transducers, replace if faulty.
Ext. Lock LED on. (S8500 only)	RF cable not connected to ultrasonic power supply.  Ext. Lock switch closed through I/O connector.	Connect RF cable to ultrasonic power supply.  Open Ext. Lock switch.
Cannot turn sweep mode on. (S8500 only)	Power Modulation mode on.	Turn PWR MOD off.
Cannot turn Power modulation on. (S8500 only)	Sweep mode on.	Turn SWEEP off.
Sys Fault and/or RESET LED's on.	Incompatible load, power, or frequency connected to ultrasonic power supply.	Check model numbers of tanks or immersible transducers connected to ultrasonic power supply. Refer to section 3 of the manual for more information.

	<p>Faulty connection between ultrasonic power supply and load.</p> <p>Faulty component connected to ultrasonic power supply.</p> <p>Low line voltage.</p> <p>RF cable not connected to ultrasonic power supply.</p>	<p>Check RF cable and all connecting cables for open or short circuits.</p> <p>Refer to troubleshooting the load in this section.</p> <p>Check that the line voltage is above 190VAC.</p> <p>Connect RF cable to ultrasonic power supply.</p>
--	---	---

### 6.3 Trouble-shooting the Load

Troubleshooting the load involves inspecting and testing ultrasonic equipment connected to the ultrasonic power supply. Instructions follow for testing RF connections and transducers connected to the ultrasonic power supply.

**Warning:** *Transducer (elements) can hold a high voltage charge. Before troubleshooting or making repairs, discharge voltage by momentarily shorting pins A and B of the RF connector that plugs into the ultrasonic power supply.*

**Note:** Take capacitance measurements at room temperature.

Step	Action
1	Turn off AC voltage to ultrasonic power supply.
2	Disconnect RF cable to tank or immersible transducer.
3	Inspect tank and immersible transducers for cracks, discolorations, or charred spots.
4	Short pin A (red) and pin B (black) of the RF cable connector to remove any electrical charge.
5	Connect an ohmmeter – set to resistance scale R x 10K – to pins A and B of the RF connector. If the meter indicates a short circuit, follow the steps below.
6	<p>Troubleshoot as follows:</p> <ol style="list-style-type: none"> <li>For ultrasonic tanks: (a) drain tank; (b) remove bottom cover; and (c) inspect transducers and RF cable for a short circuit.</li> <li>For immersible transducers: check fittings and junction boxes for a short circuit.</li> <li>If you cannot find a short circuit, test transducers as follows:</li> </ol>
7	<p>Do a DC Hi Pot test:</p> <ol style="list-style-type: none"> <li>Connect DC Hi Pot positive red lead to pin; connect black negative lead to pin B.</li> <li>Apply 2500 VDC to the load. If the test indicates leakage</li> </ol>

	over 400 $\mu$ A, repair or replace the faulty component. If the meter does not indicate leakage, check capacitance of transducers.
8	Shake an immersible to check immersible transducers for debonding,. One or more element has debonded if the transducer rattles

**Warning:** *Transducer (elements) can hold a high voltage charge. Before troubleshooting or making repairs, discharge voltage by momentarily shorting pins A and B of the RF connector that plugs into the ultrasonic power supply.*

**Note:** 1. Take capacitance measurements at room temperature.

2. Capacitance values: 25 kHz = 0.0040 uF ( $\pm 7\%$ ); 40 kHz = 0.0044 uF ( $\pm 7\%$ ).

Step	Action
8	Take capacitance measurements as follows: <ol style="list-style-type: none"> <li>1. Determine capacitance values in <math>\mu</math>F:               <ul style="list-style-type: none"> <li>• 25 kHz – 0.0040 x # of transducers (<math>\pm 7\%</math>)</li> <li>• 40 kHz – 0.0044 x # if transducers (<math>\pm 7\%</math>)</li> </ul> </li> <li>2. Use a capacitance meter to test each set of transducers.</li> <li>3. If the capacitance meter displays a value varying by more than 7% replace the set of transducers.</li> </ol>

## 6.4 Resistance Charts

### 6.4.1 Overview

Doing point-to-point resistance checks can help isolate circuit defects which produce a significant change in resistance readings. The following resistance charts list specific circuit points on the modules, expected resistance values between these points, and steps to take if expected and actual resistance measurements do not match.

**Warning:** *Ultrasonic Power supplies produce high voltage. Before working on an ultrasonic power supply, do the following: (1) turn off the ultrasonic power supply and unplug AC voltage; and (2) remove the cover and allow at least 1 minute for capacitors to discharge.*

### 6.4.2 Using Resistance Charts

To use the resistance charts:

1. Set your ohmmeter to diode test.
2. Measure the diode resistance at the circuit test points listed in columns 1 and 2. (Refer to Figure 6-1, which contain drawings showing the test points.)
3. Compare resistance values on your ohmmeter with the resistance values listed in Column 3.
4. If the two values differ, the driver board assembly is bad. Check the assembly part number before calling for replacements.

**Table 10 Diode Resistances**

Diode meter test leads		Reading
+	-	
TP-1	TP-2	OPEN-CIRCUIT
TP-2	TP-3	0.35-0.55
TP-3	TP-1	0.35-0.55
TP-6	TP-7	OPEN-CIRCUIT
TP-7	TP-8	0.35-0.55
TP-8	TP-6	0.35-0.55
TP-5	TP-4	0.7-1.0
TP-9	TP-10	OPEN-CIRCUIT
TP-10	TP-9	OPEN-CIRCUIT

**Figure 6-1 Driver Board Test Points**

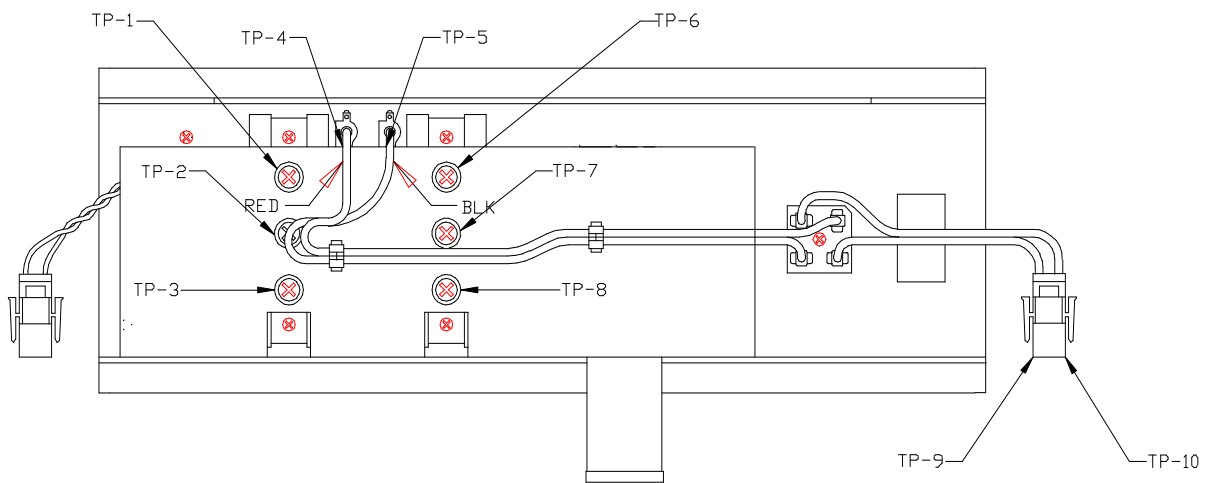

## 6.5 Cavitation Erosion

Cavitation erosion is a natural consequence of operating ultrasonics. It appears initially as a dulling of the radiating surface and proceeds to pitting and eventually may penetrate the metal so that the tank or transducer becomes unusable. The rate of erosion depends upon the ultrasonic frequency, the temperature of the liquid, the chemistry in the tank, the hardness of the tank, the power setting of the generator and many other factors.

### 6.5.1 Repairing Cavitation Erosion Marks

There is no reliable method of repairing cavitation erosion

### 6.5.2 Minimizing Cavitation Erosion

To reduce cavitation erosion:

- Operate the ultrasonics only when actually cleaning parts.
- Set the power level to the minimum setting that will produce clean parts.

**Figure 6-2 Ultrasonic Power Supply Top View**

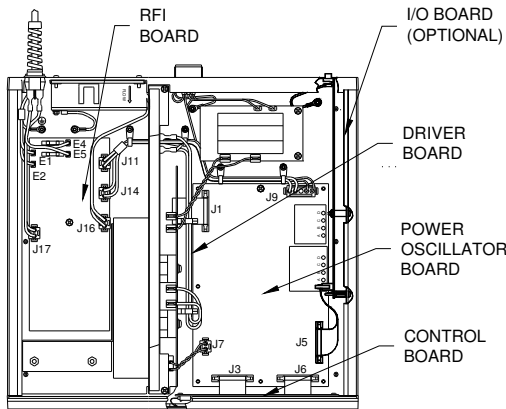

## 6.6 Parts List

**Table 11 Spare Parts List**

Part	Part Number
Adjustment tool	100-106-009
Fuse 16A, 250VAC	200-049-116R
Fuse 10A, 120VAC	000-135-069R
Fan 230VAC	200-126-012
Fan 115VAC	200-126-009
Membrane Keypad S8500	100-242-278
Membrane Keypad S8300	100-242-311
25-40kHz Driver Board	100-242-310
80-170 kHz Driver Board	100-242-369
On/Off Switch DPST	200-099-230
Power Oscillator Board	100-242-661
Control Bd. S8500	100-242-289
Control Bd. S8300	100-242-339
RFI Bd. 230V	100-242-304
RFI BD 120V	CPN-242-224



Figure 6-3 Interconnection Diagram

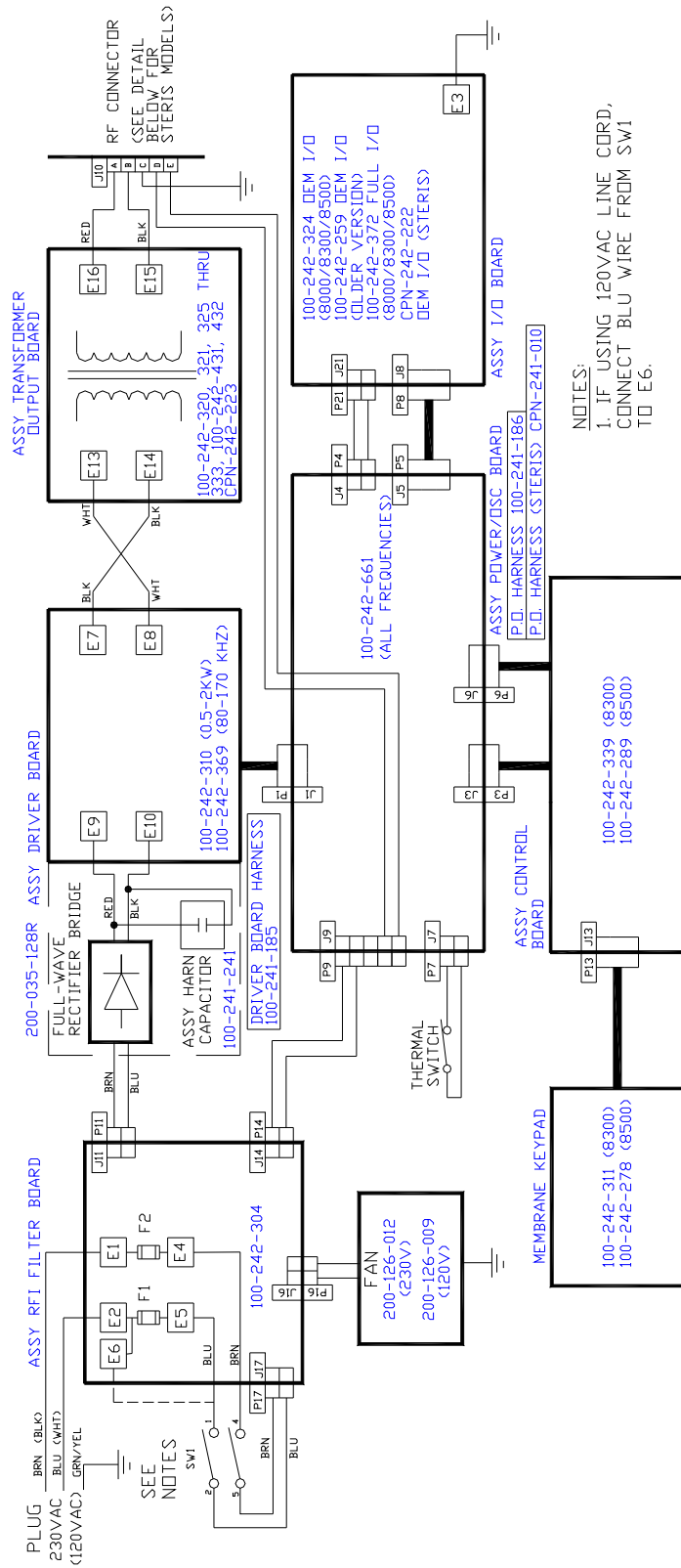

---

# **S83/85 Ultrasonic Generator**

## **A40-064**

---

## 7 Options

### 7.1 Full Feature Input/Output Board (101-063-561)

The Input/Output (I/O) board kit is an accessory that allows you to operate the S83/S85 power supply remotely. The I/O board includes two ports on the back panel of the power supply: (a) a 2-position switch for selecting remote (I/O) or local (power supply) controls; and (b) a 25-pin D-shell connector that you connect to your controls.

#### 7.1.1 Removing the Cover

**Warning:** *Ultrasonic Power supplies produce high voltage. Before working on an ultrasonic power supply, do the following (1) turn off the ultrasonic power supply and unplug AC voltage; and (2) before removing the cover, allow at least 1 minute for capacitors to discharge.*

Figure 7-1 Removing The Cover

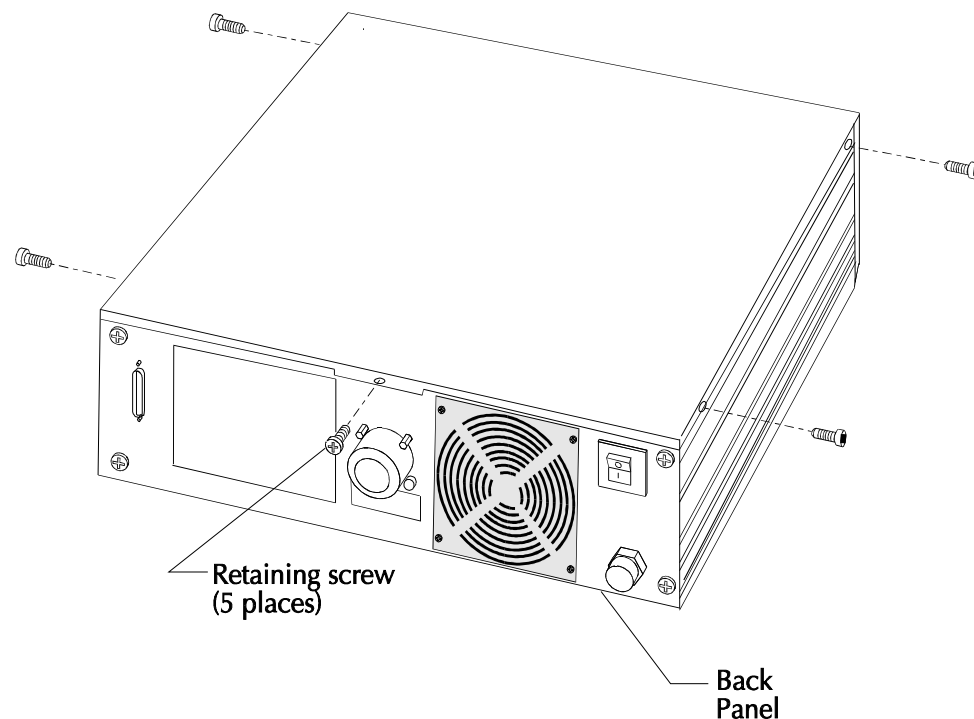

Step	Action
1	Turn the power supply to Off; unplug main AC power.
2	Remove the five retaining screws (Figure A-1).
3	Lift the cover off.
4	Place the cover out of the way.

---

## 7.1.2 Installing the I/O Board

Figures Figure 7-2 and Figure 7-3 contain illustrations showing how to install the I/O board in the power supply. Study the illustrations, then follow the instructions in the table below.

**Figure 7-2 Installing Standoffs**

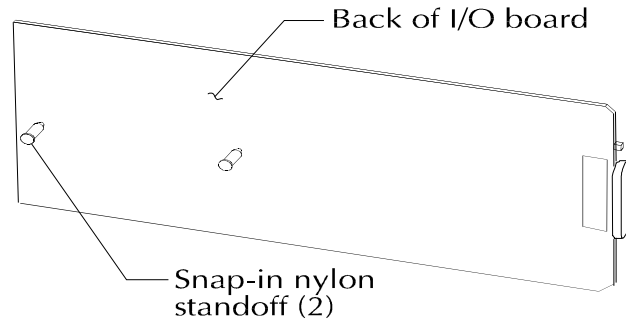

**Figure 7-3 Installing I/O Board**

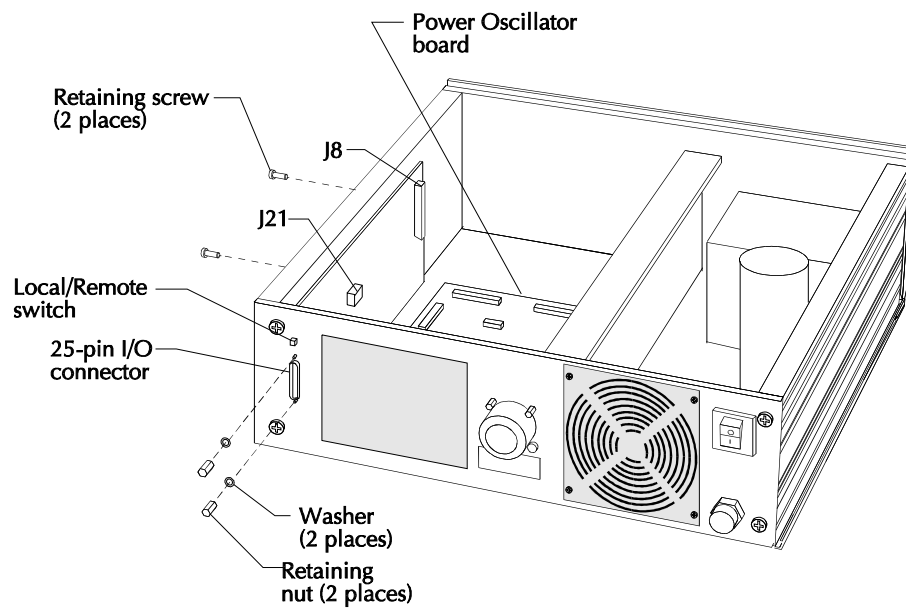

**Note:** If you are replacing an I/O board from an 8000 Series Generator to an 8500 Series connection on oscillator board is either Pin J4 or J12.

Step	Action
1	Remove the cover (Figure 7-1)
2	Install the plastic stand-offs onto the back side of the I/O board (Figure 7-2).
3	Place the board into the ultrasonic power supply (Figure 7-3).
4	Install the lug of the green and yellow ground wire to the brass stud on the Power Oscillator (P/O) board; and plug the other end of the ground wire to jumper E3 on the I/O board.
5	Line up the I/O 25-pin connector and Remote switch with the slots on the back panel. Also, make sure the standoffs line up with the holes in the left side panel of the ultrasonic power supply.
6	Insert the retaining screw through the flat washer, then through the left side panel into the standoffs in two places. Tighten the screw.
7	Insert the two hex nuts and washers on the D-shell connector screws (Figure 7-3) and tighten.
8	Make the following connections: Plug the 2-wire harness into J21 (I/O board) and to J20 (P/O board). Plug the 25-connector ribbon cable into J8 (I/O board) to J7 (P/O board).
9	Install the cover and retaining screws.

### 7.1.3 I/O Board Input Signals

Figure 7-4 Connector J2

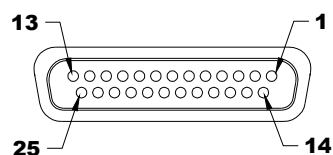

The I/O board is capable for controlling ultrasonic power using either a voltage input (0-10VDC) or a current input (0-20ma or 4-20ma). This selection is made by the state of pin 25. If pin 25 is connected to common, current control is selected. If open, voltage control is selected. If current mode is selected, the state of pin 22 controls which current range is used. If pin 22 is open, the 4-20ma range is selected. If pin 22 is closed, the 0-20ma range is selected. If voltage mode is selected, a 0-10VDC signal is applied between pins 8(+) and 7(-). To activate a function, you connect the corresponding (Figure 7-4) function pin and the common pin.

Table 12 I/O Board Input Functions

Pin No.	Function	Pin No.	Function
1	Reset	13	Common
2	Rate	15	Ultrasonics (U/S) ON/OFF
3	Power Modulation	16	Sweep
4	Interlock	17	Not Used
6	Current Mode Control Input	19	U/S Status
7	Input Common	22	Current Control Select 0-20ma – 4-20ma
8	0-10 VDC power control	25	Current or Voltage Control Select

---

### 7.1.4 I/O Board Output Functions

The I/O board outputs two status signals through isolated relay contacts.

- A “FAULT OUTPUT” contact closure occurs between pins 10 and 18 when a generator fault condition exists.
- An “U/S output” contact closure occurs between pins 19 and 18 when U/S is on.

If the current control mode is selected, a current proportional to power is output on pin 24.

If the voltage control mode is selected, a voltage proportional to power is output between pins 5 and common (7) or (13).

A +10.0VDC reference voltage is output on pin 9 (1ma max load).

A +15VDC supply (10ma max load) is output on pin 14.

Pin No.	Function	Pin No.	Function
5	0-10 VDC power meter	14	+15VDC Supply (10ma max.)
7	Common	18	Relay Output Common
9	+10VDC Reference (1ma max.)	20	Do Not Use
10	Fault Relay N.O. Contact	21	Do Not Use
11	Not Used	23	Not Used
12	Do Not Use	24	Power Level Current Output

### Full Feature I/O Board Circuits

#### I/O Board Analog Functions

The I/O Board also carries four analog signals:

1. Power Adjustment (input) - an external 0-10 VDC source controls the power level of the ultrasonic power supply.
2. Power Level (voltage) - outputs the power level of the ultrasonic power supply via a 0-10 VDC signal. Figures A-5, A-6, A-7, and A-8 contain circuit diagrams for circuits that handle the input and output functions of the I/O board.
3. Current Adjustment (input) - an external 4 to 20ma or selectable (0-20ma) current source, controls the power level of the ultrasonic power supply.
4. Power Level (current output) - outputs the power level of the ultrasonic power supply by a current output, (either 0-20ma or 4-20ma selectable).

**Note:** The I/O board contains a set pot labeled R86 that can be used to control ultrasonic power when using external control (i.e., PLC). To enable this feature, jumper JP2 pins 1+2. While the jumper is in place you can no longer control power using J2 Pin 8.

**Figure 7-5 Discrete Input - Sinking Input Type – 6 Points**

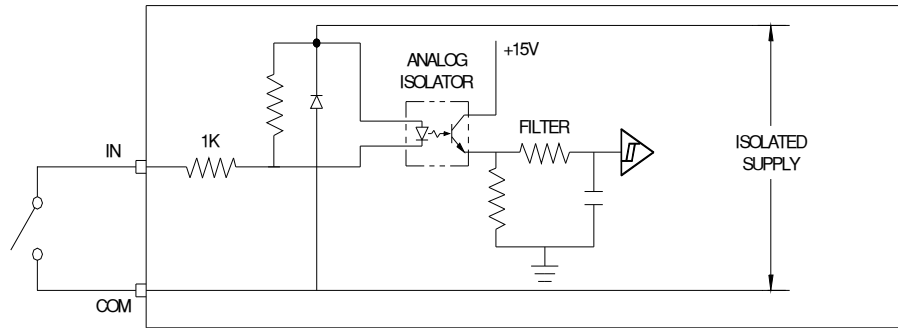

**INPUT SPECIFICATIONS**

TYPE OF DEVICE	NON-VOLTAGE CONTACTS OR NPN OPEN COLLECTOR
ISOLATION	ANALOG ISOLATION
INPUT IMPEDANCE	1K OHM

**Figure 7-6 Discrete Outputs – Normally Open Contacts – 2 Points**

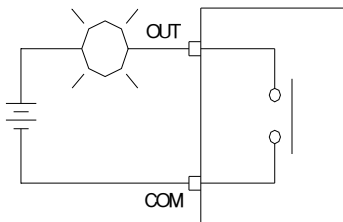

**OUTPUT SPECIFICATIONS**

TYPE OF DEVICE	RELAY CONTACT N.O.
ISOLATION	RELAY ISOLATION 5000VAC ISOLATION
OUTPUT IMPEDANCE	30 mOHMS
CONTACT RATING	24VAC OR VDC 5.0A

**Figure 7-7 Analog Input - 1 Point**

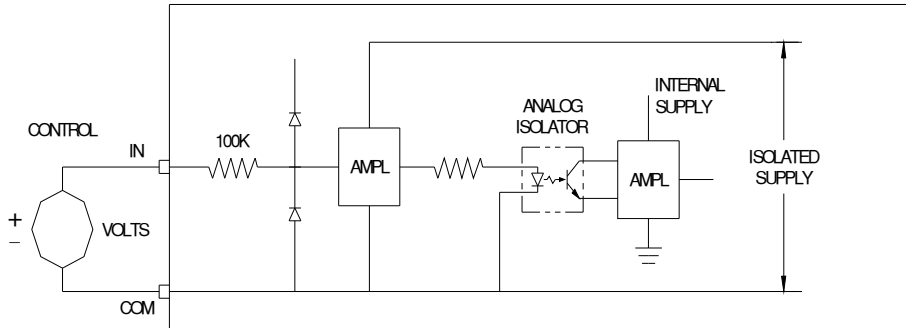

**INPUT SPECIFICATIONS**

TYPE OF DEVICE	0-10VDC VOLTAGE SOURCE
ISOLATION	ANALOG ISOLATION
INPUT IMPEDANCE	100K OHM - VOLTAGE INPUT

**Figure 7-8 Analog Output - 2 Points**

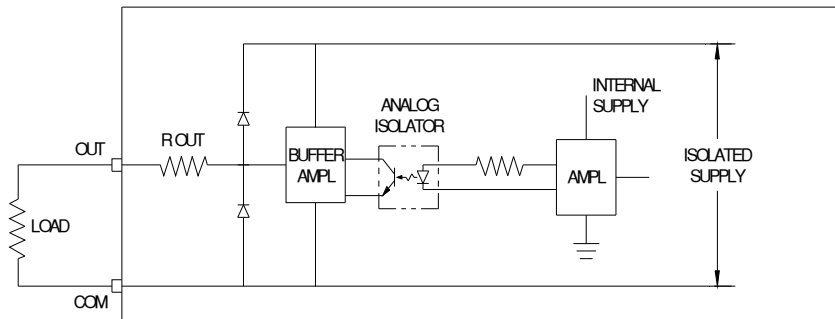

**OUTPUT SPECIFICATIONS**

TYPE OF DEVICE	0-10VDC VOLTAGE SOURCE/ (0-20mA) OR (4-20mA) CURRENT SOURCE
ISOLATION	ANALOG ISOLATION
OUTPUT IMPEDANCE	100 OHM - VOLTAGE OUTPUT 250 OHM - CURRENT OUTPUT
MAX. OUTPUT SOURCE	5mA - VOLTAGE 20mA - CURRENT



---

## 7.2 OEM-I/O Board – STD-392-317

### 7.2.1 General

The STD OEM I/O kit enables the ultrasonics to be turned on remotely by means of a switch, plc or relay. It also allows interfacing with an external interlock to stop the ultrasonics if an external fault is encountered such as a low liquid level or over temperature condition in a cleaning tank.

### 7.2.2 Kit Components

OEM I/O Board (100-242-259)

Ribbon Cable

Two wiring harnesses

Ground Wire

Terminal Block

Hardware

M3 x 25 screw

M3 nut

M3 Internal toothed washer

#6 flat washer

Plastic spacer

M4 nut

M4 flat washer

M2.5 x 8 screw Qty 2

M2.5 split washer Qty 2

### 7.2.3 Installation

**Warning:** *Be certain power is off and the power supply is unplugged before beginning the installation. The installation should only be performed by qualified personnel.*

Reference Figure 7-9 for hardware installation and locations.

Remove the power supply's top cover.

Attach the supplied ground wire to the ¼ inch GND tab located at the corner of the I/O board.

Attach and lock into place the supplied two wire harnesses to the I/O board's header J21.

Attach and lock into place the supplied ribbon cable to the I/O boards header J8.

Place the I/O board into the power supply so that the I/O board's four position header J2 extends through the cutout at the back of the power supply.

Secure the I/O board to the back panel by installing the two M2,5 screws and split washers through the power supply's back panel and into the I/O boards metal bracket.

Secure the I/O board to the side panel by installing the supplied M3 x 25 screw, #6 flat washer, plastic spacer, M3 internal tooth washer and M3 nut.

---

Secure the I/O board's ground wire ring tongue terminal to the power supply's chassis M4 stud with the supplied M4 flat washer, M4 split washer and M4 nut in that order.

Attach and lock the I/O board's ribbon cable to the power supply's main board header J7.

Attach and lock the I/O board's two wire harnesses to the power supply's main board header J20.

Place the top cover back on the power supply and secure to the sides with screws.

#### **7.2.4 OEM I/O Operation**

The OEM I/O is electrically in parallel with the front panel. Two functions are provided with the I/O board, Ultrasonics ON-OFF and external lock. The controls are dry contact type and are activated by switch closure. The I/O board's terminal block should be connected with 24 AWG wire or larger.

To activate ultrasonics, connect the terminal block pin 1 to pin 2. To deactivate, disconnect pin 1 from pin 2.

To activate external lock, connect the terminal block pin 3 to pin 4. To deactivate, disconnect pin 3 from pin 4. The external fault and reset must be cleared by depressing the RESET button located at the front of the power supply.

**Figure 7-9 OEM-I/O Board Installation**

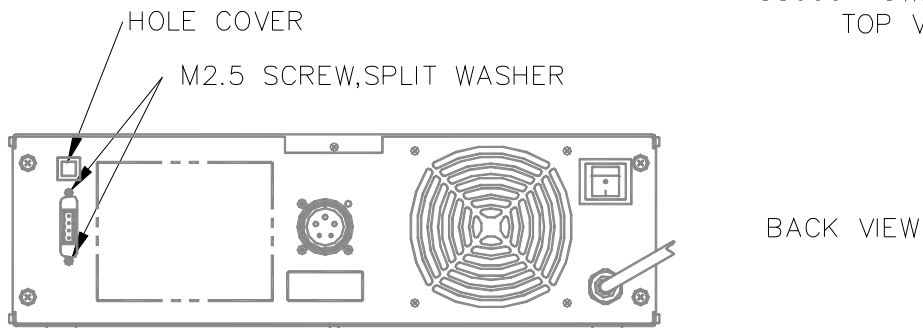
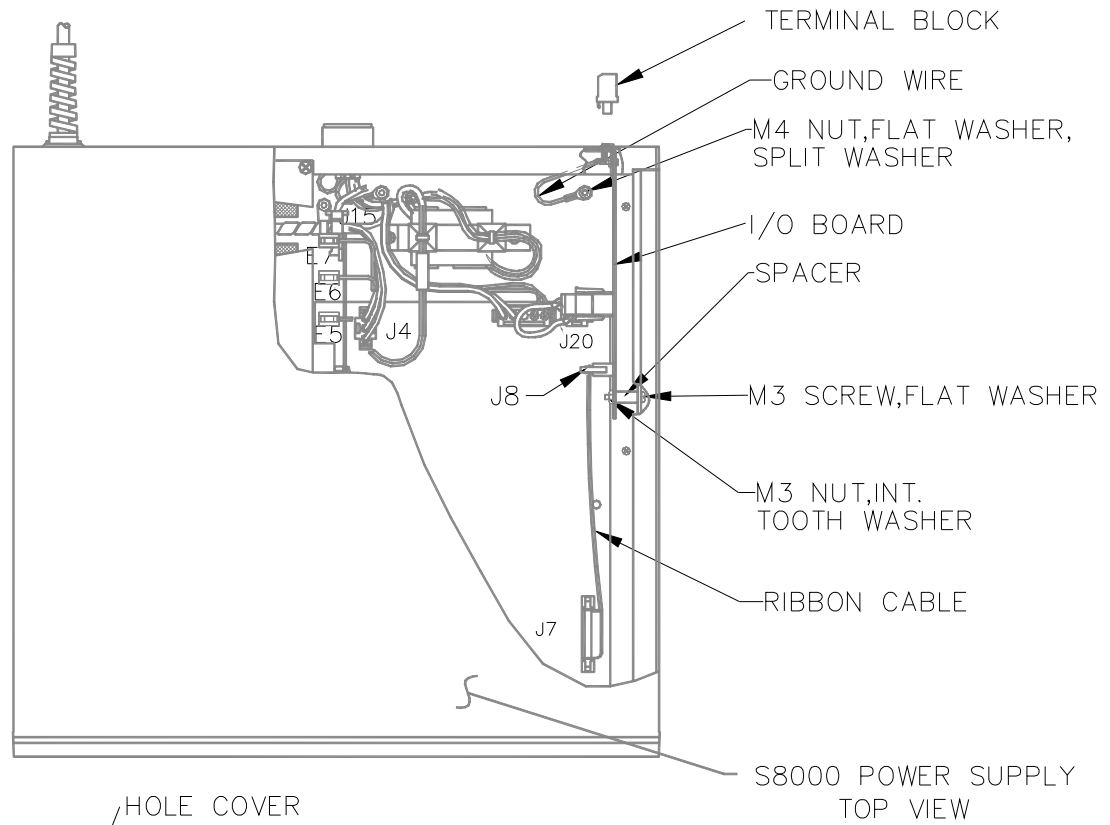

EXTERNAL CONTROLS CONNECTIONS FOR OEM I/O BOARD

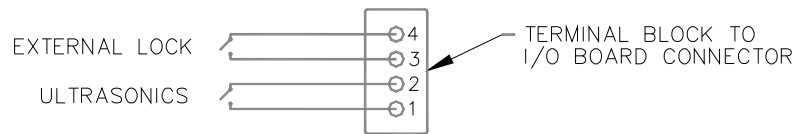

---

## 7.3 OEM-I/O Board – 101-063-503

### 7.3.1 General

The 101-063-503 OEM I/O kit enables the ultrasonics to be turned on remotely by means of a switch, plc or relay. It also provides a signal that indicates that the ultrasonics are operating.

This option may be used with S8000, S8300 or S8500 power supplies.

### 7.3.2 Kit Components

OEM I/O Board (100-242-324)

Ribbon Cable

Ground Wire

Terminal Block

Hardware

M3 x 25 screw

M3 nut

M3 Internal toothed washer

#6 flat washer

Plastic spacer

M4 nut

M4 flat washer

M2.5 x 8 screw Qty 2

M2.5 split washer Qty 2

### 7.3.3 Installation

**Warning:** *Be certain power is off and the power supply is unplugged before beginning the installation. The installation should only be performed by qualified personnel.*

Reference Figure 7-9 for hardware installation and locations.

Remove the power supply's top cover.

Attach the supplied ground wire to the ¼ inch GND tab located at the corner of the I/O board.

Attach and lock into place the supplied two wire harnesses to the I/O board's header J21.

Attach and lock into place the supplied ribbon cable to the I/O boards header J8.

Place the I/O board into the power supply so that the I/O board's four position header J2 extends through the cutout at the back of the power supply.

Secure the I/O board to the back panel by installing the two M2,5 screws and split washers through the power supply's back panel and into the I/O boards metal bracket.

Secure the I/O board to the side panel by installing the supplied M3 x 25 screw, #6 flat washer, plastic spacer, M3 internal tooth washer and M3 nut.

Secure the I/O board's ground wire ring tongue terminal to the power supply's chassis M4 stud with the supplied M4 flat washer, M4 split washer and M4 nut in that order.

Attach and lock the I/O board's ribbon cable to the power supply's main board header J7.

Attach and lock the I/O board's two wire harnesses to the power supply's main board header J20.

Place the top cover back on the power supply and secure to the sides with screws.

### 7.3.4 OEM I/O Operation

The OEM I/O is functionally in parallel with the front panel US switch. Two external functions are provided with the I/O board, ultrasonics ON/OFF and ultrasonics ON/OFF status. Both functions are accessed through a 4 position terminal block located on the end of the I/O board. Ultrasonics can be toggled on or off from a dry switch closure or a 24VAC or 24VDC source, depending on how the I/O board is configured. The factory setting is for dry switch closure. Ultrasonic ON/OFF status is read from a normally open output relay contact on terminals 3 and 4 of the terminal block.. Ultrasonic ON/OFF control is activated from terminals 1 and 2 of the terminal block.

### 7.3.5 Specifications

	Isolation Type	Voltage Range	Maximum Current
Input:	Optical	12-30 VDC 10-27 VAC	N/A
Output:	Relay	0-30 VDC 0-48 VAC	N/A

The OEM I/O board can be configured to activate ultrasonics with an external switch closure or an external 24 VAC or 24 VDC voltage source.

Figure 7-10 OEM I/O Configuration

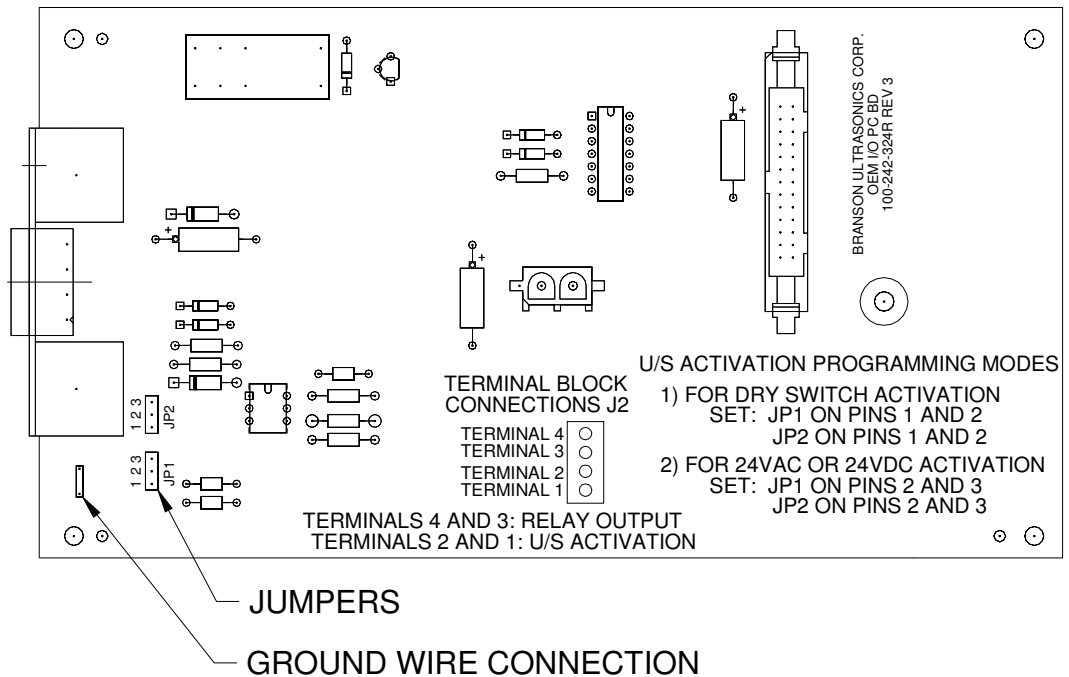

Input Control Type	Jumper Settings	Terminal Connections
Dry switch closure (Factory setting)	JP1 on pins 1 and 2 JP2 on pins 1 and 2	U/S on: Close switch across terminals 1 and 2
24VAC source	JP1 on pins 2 and 3 JP2 on pins 2 and 3	U/S on: Connect 24VAC source across terminals 1 and 2
24VDC source	JP1 on pins 2 and 3 JP2 on pins 2 and 3	U/S on: Connect +24VDC to terminal 1, connect +24VDC common to terminal 2

Figure 7-11 External Wiring Diagrams

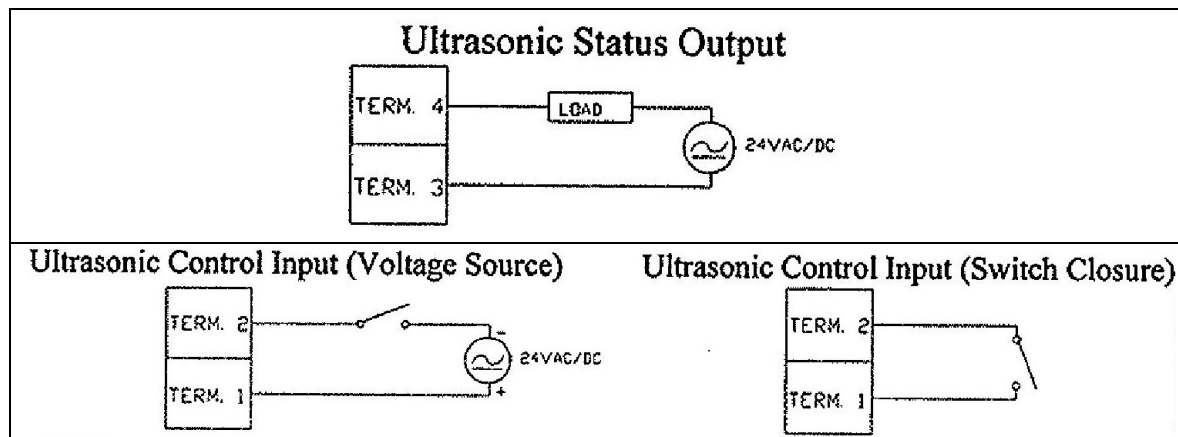

**Figure 7-12 OEM I/O Installation**

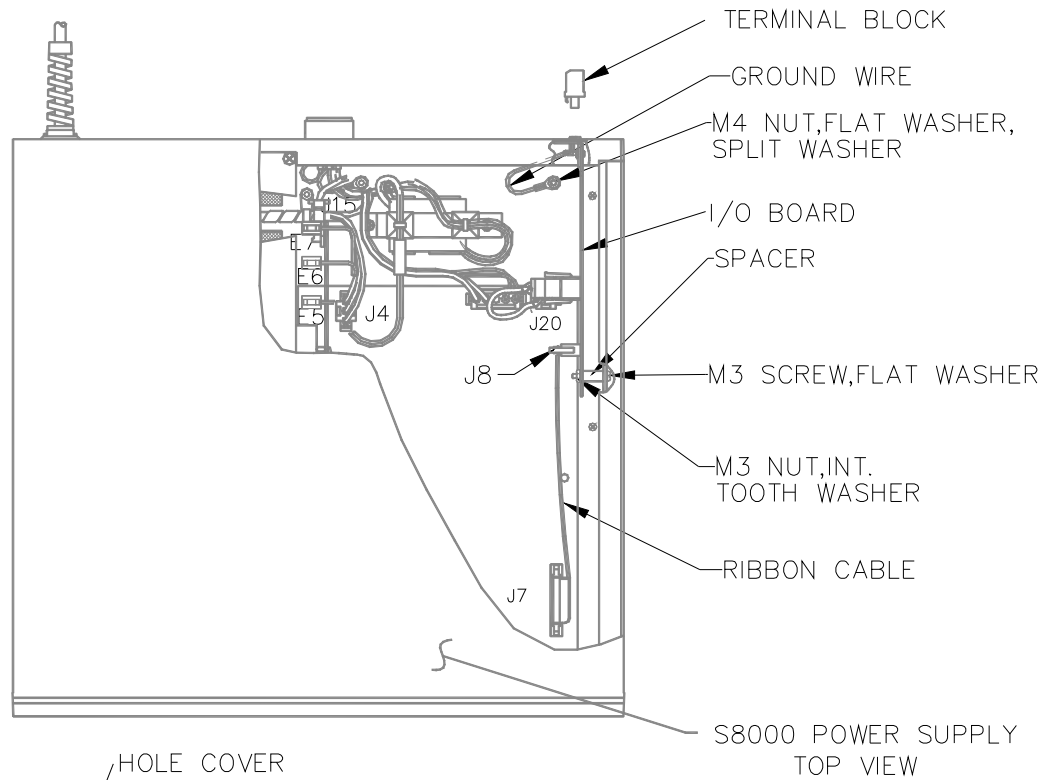

EXTERNAL CONTROLS  
CONNECTIONS FOR OEM I/O BOARD

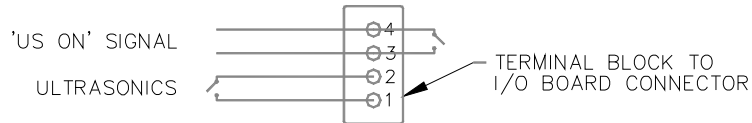

## 7.4 Timer Option

The timer option consists of a mechanical timer that plugs into the OEM-I/O terminal in the back of the generator. It includes an 8 foot cord so that it may be located in any convenient location within 8 feet of the generator. It requires no additional power or connections.

To use the timer:

- Turn the generator power switch on the back of the generator to the on position
- Turn the knob to the desired setting
- Release the knob. The generator will turn on and operate for the set number of minutes then turn off.

**Figure 7-13 Timer Option**

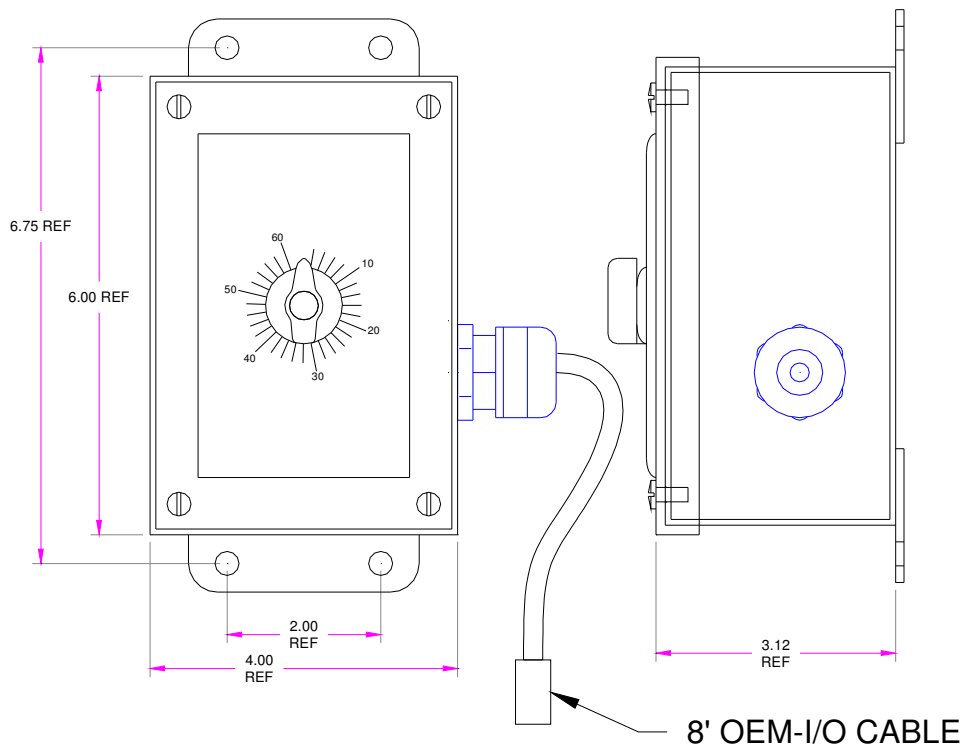



---

## 7.5 Rack Mount Kit

The Rack Mount Kit consists of two brackets, handles and the hardware to mount them. Assemble the handles to the brackets and mount the brackets onto the generator as shown using the hardware provided with the kit. The mounting slots on the bracket will fit a standard 19 inch rack.

**Caution:** Do not use the rack mount kit to support the generator. Use a shelf or support rails instead.

Figure 7-14 Rack Mount Kit

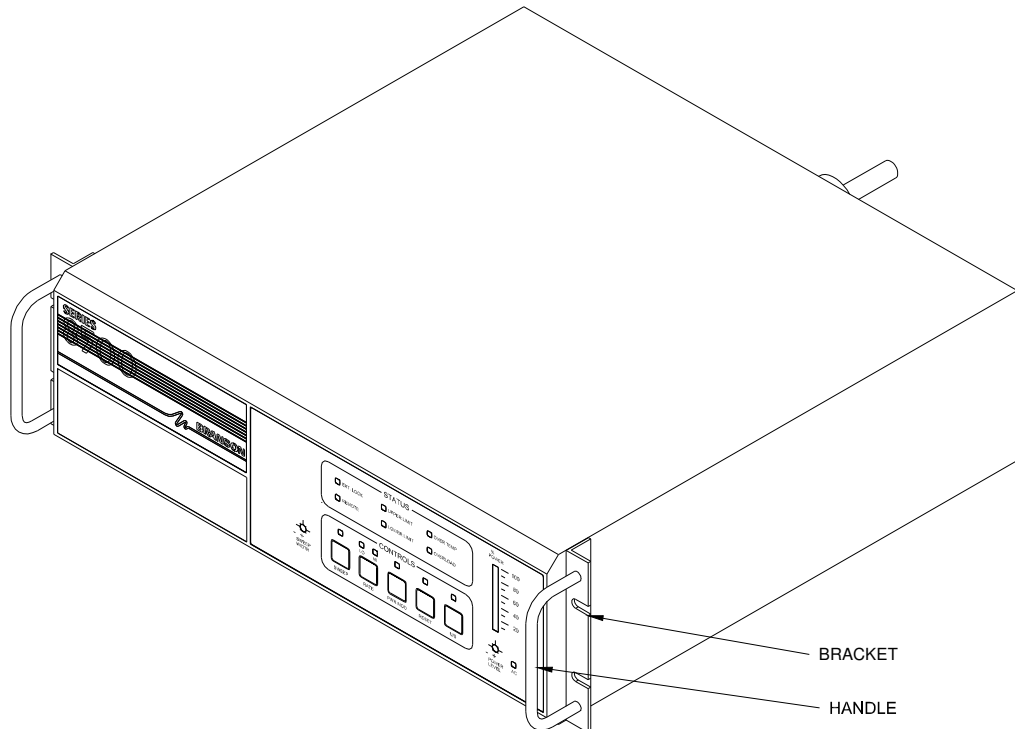



---

# **S83/85 Ultrasonic Generator**

## **A40-064**



---

## 8 Assistance

### 8.1 Calling the Local Branson Representative

If you have a problem call the local Branson field sales or service representative, who will know you, your needs and your applications. He may have a critical replacement part in stock that will return your machine to operation in the shortest possible time. Before you call, take the following steps:

1. Have this manual with you.
2. Know how your system has been set up and equipped, including any software versions in
3. your system.
4. Describe the problem.
5. List the steps you have already taken.
6. Have a list of service spares on hand.
7. Enter the name and phone number of your Branson Representative here:

Name: \_\_\_\_\_

Phone \_\_\_\_\_

#### Calling Branson, Danbury

If the local Branson representative is unavailable, and you do not have the direct dial number for that individual, call Branson in Danbury at (203) 796-0400 and follow the automated voice system to the area you need.

You can also call after 5:00 P.M. or before 8:00 A.M. (Eastern Standard Time), or at any time during weekends and holidays and leave a message in the Corporate Mailbox. This message will be relayed to the correct department and answered during the next working day.

---

## 8.2 Obtaining Replacement Parts

If you need to purchase replacement parts, coordinate the following with your purchasing agent:

1. Purchase Order Number.
2. Ship to: \_\_\_\_\_
3. Bill to: \_\_\_\_\_
4. Shipping instructions -- air freight, truck, etc.
5. Special instructions (for example, "Hold at the airport and call"). Be sure to give a name and phone number.
6. Call the Branson Parts Store at (203) 796-0575 or (203) 796-0330, OR If you know the part number(s), fax your order, including the information listed above, to (203) 796-0574.

Most parts can be shipped within 24 hours from the time they are ordered.

---

### 8.3 Returning Equipment

When returning any part or equipment to the Branson factory, it must be accompanied by a Returned Goods Authorization (RGA) number. This number is used to ensure proper handling and identification of your part or equipment and to expedite its repair and/or return. All returns or repairs should be sent to the Danbury, CT facility unless otherwise directed by Branson personnel. All goods must arrive at the Danbury facility with an authorized RGA number clearly marked on the package, or it will be returned, freight collect. RGA numbers are not required for repairs by field offices.

To obtain a RGA number for returning parts or equipment you must notify the Industrial Cleaning Repair Service Department at (877) 330-0405 or Fax (877) 330-0404. Please specify model, P/N, and reason for return. If you are returning equipment for repair, please call (877) 330-0405 or Fax (877) 330-0404.

- Please indicate fully and clearly the billing and shipping address(es).
- For equipment not covered by the warranty, include a purchase order to avoid delay.
- Pack carefully to avoid damage in shipment.
- Return general repairs by any convenient method. Send priority repairs by Air Freight.
- Prepay the transportation charges FOB the repair site.

