

## SECTION 12.1 EPS 2100 SETUP

### DESCRIPTION

The EPS 2100 level controller is equipped with a pressure transducer, alpha/numeric display, output modules and terminal strips.

The front panel is equipped with displays and controls with the following functions: (refer to Figure 1)

Alpha/Numeric LCD Display: Displays wet well level, setpoints and setup parameters.

Output Status LED's: Illuminates when an output is on.

Active Setpoint Bank LED's: Illuminates to indicate the active setpoint bank, either 1-2-3-4 or 5-6-7-8.

G-R Logo Key : Pressing this key allows operator access to setup parameters. Steps through parameters sequentially when pressed. May be password protected.

Setpoint Increment/Decrement Key [▼▲]: Changes level setpoints and setup parameter values. Adjusts simulated levels in Simulate mode.

SHIFT/ENTER Key: Shifts between output banks when making setpoints. Enters password digits, calibration values and setpoint assignments.

ON/OFF Key: Displays On and Off setpoints when pressed. Setpoint may be adjusted when displayed.

SIMULATE Key: Toggles control between level simulation and normal operation. Use [▼▲] keys to force outputs on and off when in simulate mode.

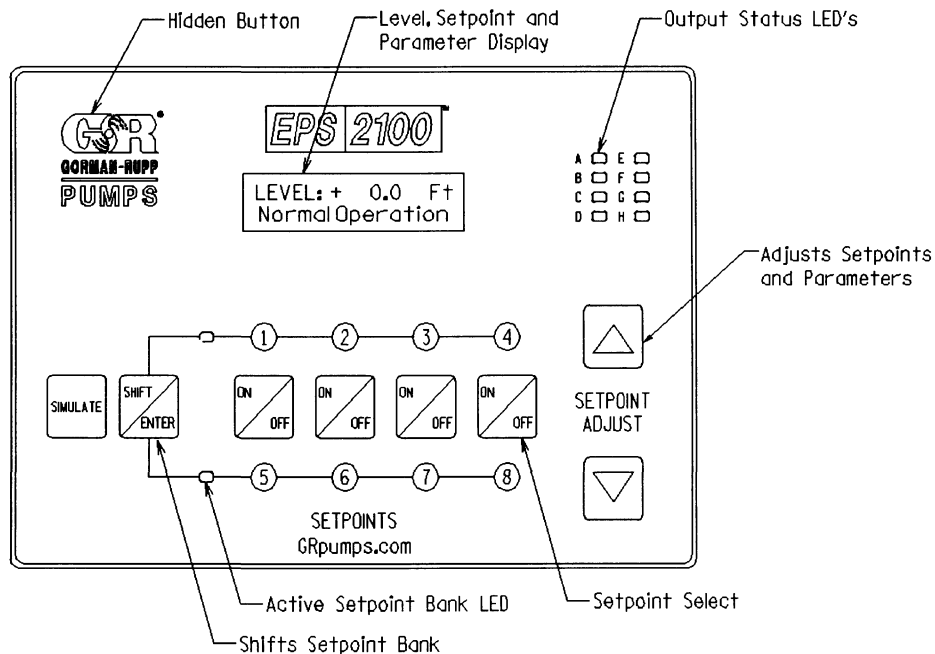

Figure 1, Front Panel

The back of the EPS 2100 includes the following: (refer to Figure 2)

Air Bubbler Transducer Input: Accepts tubing connection from air bubbler line.

Analog Input Terminal Strip: Accepts analog inputs from various level sensing instruments. (See Figure 5 through 10).

Analog Output and Supply Terminal Strip: Provides scaleable analog outputs proportional to level. Can be used for metering, drive control or SCADA. (Refer to Figure 9 and 10)

Digital Output Terminal Strip: Connects output relays to motor starters, relays and alarms.

Output Status LED's: Illuminates to indicate the output relay is called to turn on.

Output Relays: Up to 8 solid state output relays may be installed. Each socket accepts either a 120 Vac or a 12 to 24 Vdc relay. 120 Vac relays are model MP120D4. 12 to 24 Vdc relays are model DC200MP.



**Refer to the control panel wiring diagram to determine proper output relay voltage. DC modules will not function properly in an AC circuit and AC modules will not function properly in a DC circuit.**

Output Fuses: Protects output relays from overloads or short circuits

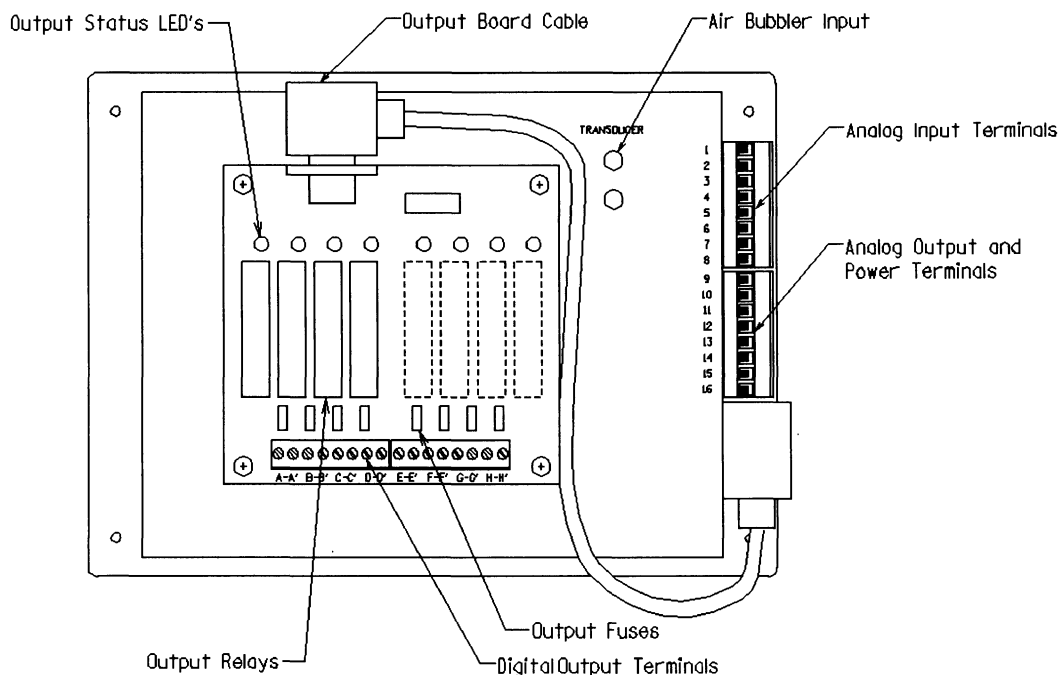

Figure 2, Back

## OPERATOR ADJUSTMENTS

### Setpoints

1. Press the SHIFT/ENTER button on the front of the EPS 2100 controller to toggle between the active bank of outputs, bank 1-2-3-4 and bank5-6-7-8. Refer to the LED indicator adjacent to each bank.
2. Press the respective ON/OFF button on the front of the EPS 2100 controller for each output. This button toggles between ON and OFF set points and displays the current setting of each. If the display indicates that the Set points are locked, refer to the EPS 2100 Setup in Section 12.1.
3. Use the Set Point Adjust Arrow keys [▲▼] to adjust the set point levels. All set points are saved automatically.
4. Repeat steps 2, 3, and 4 to set all other set point ON and OFF levels.

### NOTE

*Pump ON levels should be set at least 0.3 feet or more above the pump OFF levels. Closer settings may cause short cycling of the pumps.*

### NOTE

*The set points are independent and do not interact with other set points. The set point display buttons may be depressed at any time without effecting pump operation.*

### Simulation

Press [SIMULATE] to change to Simulate Mode of operation. In this mode, the operator can simulate

level changes. PRESS [▲] to simulate a level increase or [▼] to simulate a level decrease.

When finished simulating, PRESS [SIMULATE] to return to Normal Mode of operation. The EPS 2100 will return to the Normal Operation screen automatically after a short delay or immediately by pressing the Simulate key twice.



**Pumps and other devices connected to outputs may suddenly energize when in the simulate mode.**

## COMMISSIONING

### Enter Access Code

You must enter the access code to unlock setup. The valid access code is 0305.

Press  to display:

#### Enter Access Code:

XXXX

(Digits are only displayed when [▲▼] is depressed)

1. Press [SHIFT/ENTER] to accept the digit “0”. The cursor shifts to the next digit to the right.

XXXX

2. Press [▲] three times to change digit above cursor to a “3”.
3. Press [SHIFT/ENTER] to accept the digit “3” and shift to the next digit to the right.

XXXX

4. Press [SHIFT/ENTER] to accept the digit “0” and shift to the next digit to the right.

XXXX

5. Press [▲] five times to change digit above cursor to a “5”.
6. Press [SHIFT/ENTER] to accept the digit “5” and the screen will display:

#### Current Setup is:

**Locked**

7. PRESS [▲▼] to change to **Unlocked**.
8. After setup adjustments have been made, setup may be password protected. Repeat steps (1) through (6) and Press [▲▼] to change current setup to **Locked**.

## SETUP ADJUSTMENTS

### Analog Input Type (See Figure 5 through 10)

Press . The screen will display:

**Analog Input Type:  
Internal Transducer**

1. To change the input type, press [ $\blacktriangle$   $\blacktriangledown$ ], scrolling through the available choices until the desired input type is displayed.
2. Press  accept the new value and step to the next parameter.

### NOTE

*Zero and span calibrations are only necessary to calibrate a new EPS, or when replacing the transducer. Once calibrated, settings are stored in non-volatile memory.*

### Calibrate Zero

Zero calibration sets the value displayed when the transducer is exposed to zero water (atmospheric) pressure. To set:

Press . The screen will display:

**Calibrate Zero Setup  
XXXXX = 00.0 Ft**

1. Apply zero pressure to the EPS input. Allow several seconds for the EPS 2100 reading to stabilize.
2. Press [SHIFT/ENTER]. This saves the input value to display 00.0 Ft.

### Calibrate Span Setup

Span calibration sets the value displayed when the the transducer is exposed to a known water pressure (depth). To set:

Press . The screen will display:

**Calibrate Span Setup  
XXXXX = XX.X Ft**

1. Apply a known depth greater than 00.0 Ft to the EPS input, e.g. 12 feet of water. Allow several seconds for EPS 2100 reading to

stabilize. Adjust the display to this same applied level using the [ $\blacktriangle$   $\blacktriangledown$ ].

2. Press [SHIFT/ENTER]. This saves the input value to display the span entered. In this example, 12.0 Ft.

### Setpoint Assignment

Each setpoint can be assigned for pump, alarm or not used. To set:

Press . The screen will display:

**Setpoint Assignment:  
For 1: Not Used**

1. To change the setpoint assignment, press [ $\blacktriangle$   $\blacktriangledown$ ], scrolling through available modes until the desired assignment is displayed.
2. Press [SHIFT/ENTER] to save the selection and step to the next setpoint. Select the desired assignment as described in 1 above. Continue until all 8 setpoints have been assigned.

### Alternation

Press . The screen will display:

**Alternate B, C, D?  
Duplex**

1. PRESS [ $\blacktriangle$   $\blacktriangledown$ ] to toggle between None, Duplex, Triplex, No.1 (B)Lead, No.2 (C)Lead or No.3 (D)Lead.

None – Allows for external alternation of pumps.

Duplex – Allows internal alternation between B and C outputs only.

Triplex – Allows internal alternation between B, C and D outputs only.

No.1 (B) Lead – Allows no internal alternation. B output is always Lead on.

No. 2 (C) Lead – Allows no internal alternation. C output is always Lead on.

No. 3 (D) Lead – Allows no internal alternation. D output is always Lead on.

## NOTE

Setpoint assignments must be coordinated with alternation. B and C or B, C and D must be selected as pumps to allow duplex or triplex alternation.



2. Press  accept the new alternation setting and step to the next parameter.

### Excess Pump Runtime

(Available only when Alternation is selected)

Press . The screen will display:



**Excess Pump Runtime**  
6 Hrs

PRESS [ ] to scroll between No or 1 to 199 hours in one hour increments.

### Display Units

Press . The screen will display:



**Display Units Are:**  
English

PRESS [ ] to toggle between English and Metric.

### Pump Application

Press . The screen will display:



**Pump Application**  
Pump-Down Type

PRESS [ ] to toggle between Pump-Down Type and Pump-Up Type.

### Analog Output Type (See Figure 11 & 12)

Press . The screen will display:



**Analog Output Type:**  
4 to 20 milliAmp

Press [ ] to scroll between 4 to 20 mA, 0 to 5 Vdc or 0 to 10 Vdc

### Lower Endpoint Setting

Press . The screen will display:



**Lower Endpt. Setting:**  
4.00 mA = 0.0 Ft

Press [ ] to adjust the level (in feet or meters) setting for minimum voltage/current from Analog Output.

### Upper Endpoint Setting

Press . The screen will display:



**Upper Endpt. Setting:**  
20.00 mA = 33.3 Ft

Press [ ] to adjust the level (in feet or meters) setting for maximum voltage/current from Analog Output.

### LCD Backlight Option

Press . The screen will display:



**LCD Backlight Option**  
Always Turned on

Press [ ] to toggle Always Turned On and Off After 60 Sec.

### Backlight Brightness

Press . The screen will display:



**Backlight Brightness**  
Bright Setting

Press [ ] to toggle between Dim or Bright Setting.

### Setpoint Security

Press . The screen will display:

**Setpoints Are:**  
Unlocked

Press [ ] to toggle between Unlocked or Locked. If setpoints are locked, an operator can view the setpoints but cannot change them.

PRESS  once more to return NORMAL OPERATION mode.



When setup values are changed, they are temporarily stored in volatile memory. To save these new settings to non-volatile memory, it is important to press  to cycle through all parameters and return to the Normal Operation screen. Failure to cycle back to Normal Operation will cause the setup values to return to their previous settings.

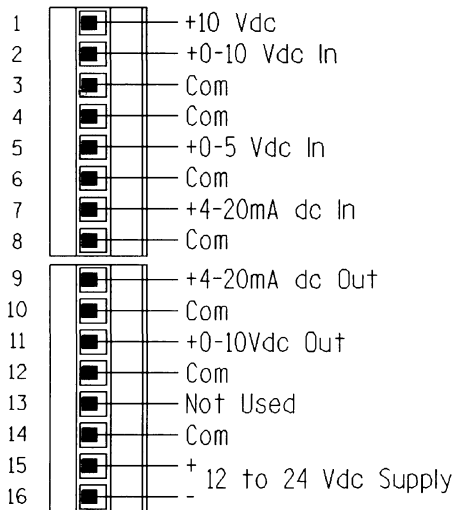

**Figure 3, Analog and Power Supply Terminals**

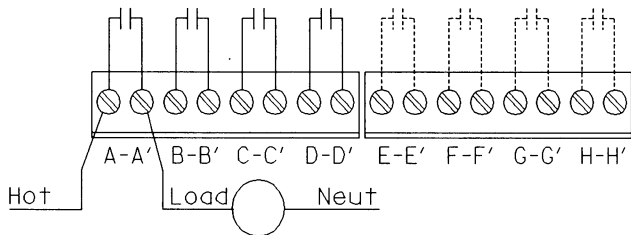

Specification:  
4 Solid state relays standard, 8 optional  
Standard Relay: Opto 22 No. MP120D4  
4 amp, 120Vac, triac

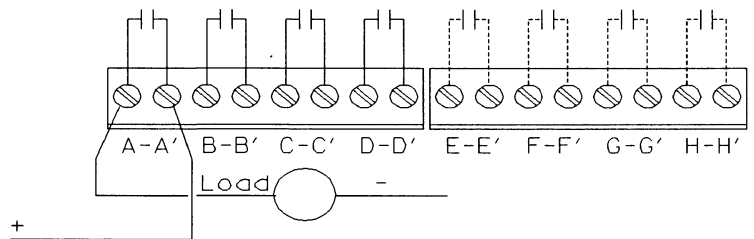

Specification:  
Optional Relay: Opto 22 No. D200MP, 1 amp  
12 to 24Vdc, transistor

**Typical Output Slot Occupied By  
Standard 120Vac Module**

**Typical Output Slot Occupied By  
Standard 12-24Vdc Module**

**Figure 4, Digital Output Terminals**

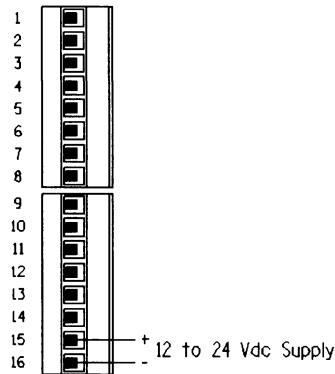

Configure Analog  
Input Type:  
"Internal Transducer"

**Figure 5, Air  
Bubbler Input**

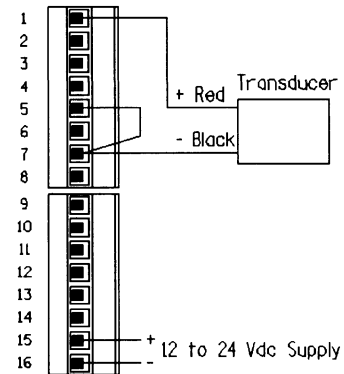

Configure Analog  
Input Type:  
"4 to 20 milliAmp"

**Figure 6, 4-20mA Input,  
Powered by EPS**

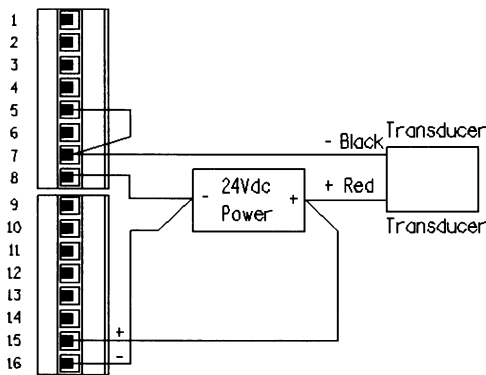

Configure Analog  
Input Type:  
"4 to 20 milliAmp"

**Figure 7, 4-20mA Input,  
Powered Externally**

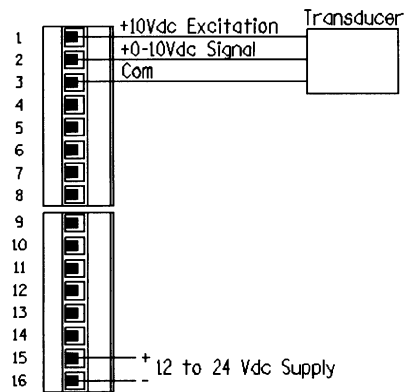

Configure Analog  
Input Type:  
"0 to 10 Volt D.C."

**Figure 8, 0-10Vdc Input,  
Powered by EPS**



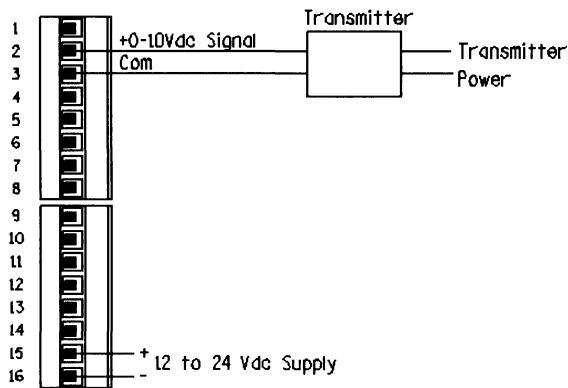

Configure Analog  
Input Type:  
"0 to 10 Volt D.C."

**Figure 9, 0-10Vdc Input,  
4-Wire Transmitter**

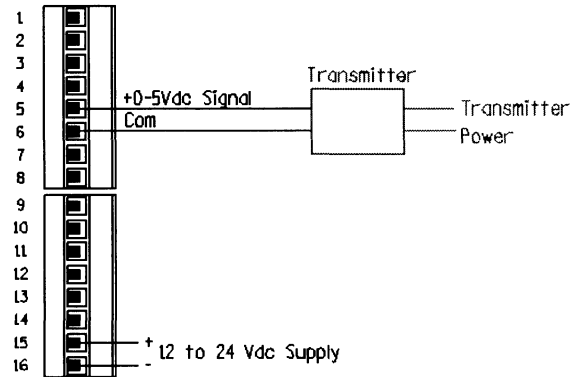

Configure Analog  
Input Type:  
"0 to 5 Volt D.C."

**Figure 10, 0-5Vdc Input,  
4-Wire Transmitter**

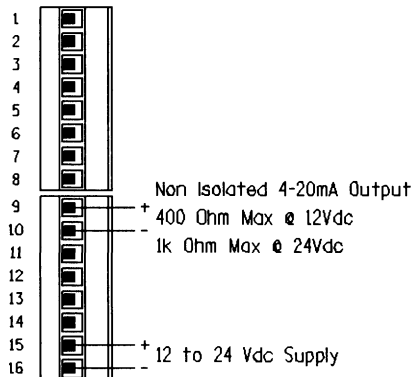

Configure Analog  
Output Type:  
"4 to 20 milliAmp"

**Figure 11, 4-20mA Output  
Powered by EPS**

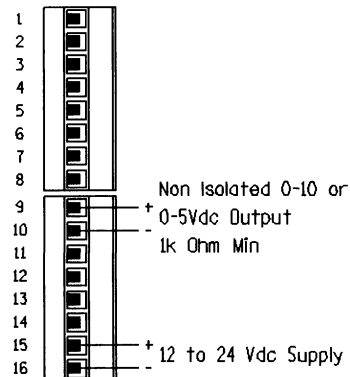

Configure Analog  
Output Type:  
"0 to 10 Volt D.C."  
or  
"0 to 5 Volt D.C."

**Figure 12, 0-10 or 0-5Vdc  
Output Powered by EPS**

