

# EPC G<sub>Embedded PC</sub> User Manual

Reg 10497/0604

CiS No.: 360.610.0070

Version 1/06.04

© Systeme Lauer GmbH & Co. KG

---

Systeme Lauer GmbH & Co KG  
Postfach 1465  
D-72604 NürtingenGermany

User Manual: EPC G<sub>Embedded PC</sub>  
Issued: June, 2004  
Author: Jung

Operating instructions, manuals and software are protected by copyright laws. All rights reserved. Copying, duplicating, translating, or converting these materials in whole or in part is prohibited. An exception is made in the case of preparing a backup copy of the software for personal use.

- The manual is subject to change without prior notification.
- We cannot guarantee that the programs and data stored on the disk are free of errors and absolutely correct.
- Since diskettes represent manipulatable data media, all we can guarantee is that there is no physical damage to them. Liability is limited to replacement.
- We welcome suggestions for improvements as well as pointing out errors at any time.
- The agreements also apply to the special appendices to this manual.

Microsoft, Windows, Windows NT and the Windows Logo are either registered trademarks or trademarks of Microsoft Corporation in the USA and/or other countries.

Other names designated in this document may be brand names, the use of which by third parties for their own purposes may violate the rights of the proprietors.

---

## Information for Users

Please read this manual before using the product for the first time, and be sure to keep it where you can make use of it later.

Unless where explicitly referred to the versions Economy Unit or Business Unit, the description applies for all units.

Intended audience                      The manual has been written for users who are familiar with PC systems and automation technology.

Conventions used in this manual    [KEY]                      Keys the user has to press on the keyboard are represented in square brackets, e.g. [CTRL] or [DEL].

   Courier                      Screen output is represented in the Courier type font, e.g. C:\>

   Courier Bold              User inputs via keyboard are identified by the Courier Bold type font, e.g. C:\>**DIR**

*Italics*                      The names of buttons, menus or other screen elements the user has to select and product names are represented in *italics*.

Safety instructions                      Wherever there may be dangerous faults in the automation equipment, i.e., where an error would cause significant property damage or injury to persons if it occurred, additional external precautions must be taken or equipment must be set up (for example by using independent limit switches, mechanical disabling locks, etc.). In the event of an error, these measures must ensure or force a safe operating status.  
Testing and verification of suitability for the purpose intended by the user, or for deployment under usage conditions, are the responsibility of the user. Systeme Lauer accepts no liability for testid.

Pictograms                                      The following pictograms have been used in the manual to identify special text passages:



Danger!  
Potentially hazardous situation.  
May result in personal injury.

---



Caution!  
Potentially hazardous situation.  
May result in property damage.

---



Tips and supplementary information

---

# Table of Contents

<b>Information for Users</b>	<b>0-3</b>
<b>Table of Contents</b>	<b>0-4</b>
<b>Company</b>	<b>0-5</b>
<b>Contact</b>	<b>0-6</b>
<b>1 Product Description</b>	<b>1-1</b>
<b>1.1 Control side</b> .....	<b>1-1</b>
1.1.1 EPC G Touch .....	1-1
1.1.2 EPC G Key .....	1-1
<b>1.2 Rear side</b> .....	<b>1-2</b>
<b>2 Commissioning</b>	<b>2-1</b>
<b>2.1 Power supply</b> .....	<b>2-1</b>
<b>2.2 Grounding diagram</b> .....	<b>2-2</b>
<b>2.3 Installation</b> .....	<b>2-2</b>
<b>T Technical data</b>	<b>T-1</b>
<b>T1 Mechanical dimensions</b> .....	<b>T-1</b>
T1.1 EPC G 1000 Outer/Mounting dimensions .....	T-1
T1.2 EPC G 1000 Unit dimensions .....	T-2
T1.3 EPC G 1200 Outer/Mounting dimensions .....	T-3
T1.4 EPC G 1200 Unit dimensions .....	T-4
T1.5 EPC G 1500 Outer/Mounting dimensions .....	T-5
T1.6 EPC G 1500 Unit dimensions .....	T-6
T1.7 EPC G 1500 V2A Outer/Mounting dimensions .....	T-7
T1.8 EPC G 1500 V2A Unit dimensions .....	T-8
T1.9 EPC G 1000k Outer/Mounting dimensions .....	T-9
T1.10 EPC G 1000k Unit dimensions .....	T-10
T1.11 EPC G 1200k Outer/Mounting dimensions .....	T-11
T1.12 EPC G 1200k Unit dimensions .....	T-12
<b>T2 Electrical data</b> .....	<b>T-13</b>
<b>T3 Ambient conditions</b> .....	<b>T-14</b>
<b>T4 Interfaces</b> .....	<b>T-15</b>
T4.1 Compact-FLASH-Slot .....	T-15
T4.2 VGA/COM Interface .....	T-15
T4.3 Ethernet, USB, PS/2 .....	T-16
T4.4 Cassette option .....	T-16

---

## Company



Elektronik-Systeme LAUER GmbH & Co. KG  
Kelterstraße 59  
D-72669 Unterensingen Germany  
Tel. +49 (7022) 9660-0  
Fax. + 49 (7022) 9660-274

### Our philosophy

Systeme LAUER is a reliable partner who thinks and acts internationally. From the LCA electronic text display and the high-tech PCS control panel to the industrial computer we supply a complete program for

- operation
- monitoring and
- control

Within the AUGUSTA Technologie AG, a group of global companies, Systeme LAUER stands for an almost unlimited product range right up to competent service.

On account of an active cooperation with our customers, our qualified team produces convincing concepts which bring man, machine and interface into line in an efficient way.

Proximity to our customers – the direct dialog – is the foundation of our success.

---

## Contact

Support

Telephone: +49 (7022) 9660-209

E-mail: [support@systeme-lauer.de](mailto:support@systeme-lauer.de)

**In case of support enquiries, please have the serial number of the device ready !**

Please access our Download Forum to find current drivers, software, drivers, manuals, ... and novelties at

<http://forum.systeme-lauer.de/>

Sales

Telephone: +49 (7022) 9660-0

E-mail: [Sales@systeme-lauer.de](mailto:Sales@systeme-lauer.de)

In addition, we offer

... training and technical courses in our modern training center, or, if you prefer, in your company.

Ask your sales partner for our current training catalog.

... not only demonstration units, but we also provide specialists who assist you personally when starting your first application.

---

# 1 Product Description

## 1.1 Control side

### 1.1.1 EPC G Touch

- 1 Color TFT-Display  
10,4", 12,1" or 15" with  
Resistiv Touch



### 1.1.2 EPC G Key

- 2 Color TFT-Display  
10,4" with Resistiv Touch

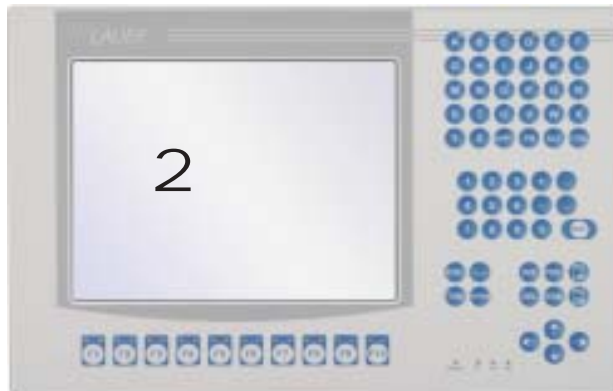

- 3 Color TFT-Display  
12,1" with Resistiv Touch



# 1 Product Description

- 4 Color TFT-Display  
15" with Resistiv Touch
- 5 Front plate V2A



## 1.2 Rear side

- 6 COM 1 / COM 2
- 7 VGA
- 8 PS/2 Mouse / PS/2 keyboard
- 9 USB 1 / 2
- aJ LAN 1 / 2
- aA Grounding screw
- aB Power supply
- aC Compact Flash





---

## 2 Commissioning

### 2.1 Power supply



#### Caution!

The EPC G must only be operated at protective extra-low-voltage as defined by European standard EN60950!

The control transformer must comply with European standard EN60742!

Compare the power supply voltage with the voltage specified on the type label.

All cable connections must be tested before commissioning the system.

You must ensure that all the voltages and signals correspond to the relevant specifications.

- 1 24 V power supply
- 2 Grounding screw



The power supply is rendered by a two-pole connector (Phoenix MST BT 2.5/2).

Power supply diagram

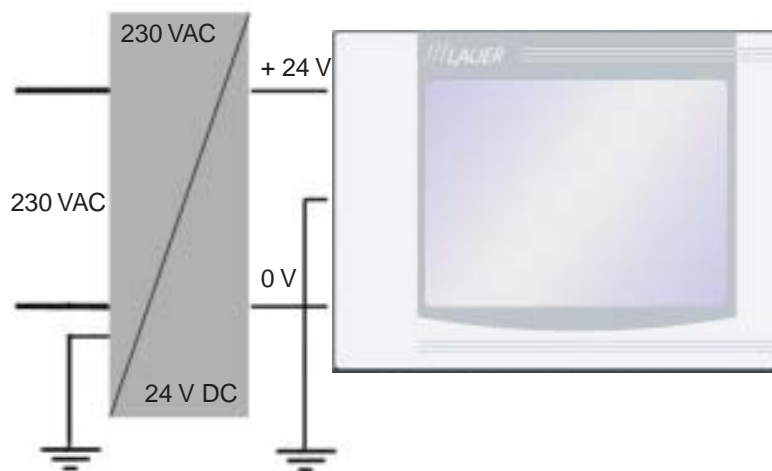

---

## 2 Commissioning

### 2.2 Grounding diagram

In order to ensure a safe diversion of electric interferences, the following points have to be observed:

- Connect the device and the switch cabinet with a central grounding point via the shortest route possible.
- Make sure the connection between the device and switch cabinet has the lowest inductivity possible.
- All the data cables connected to the device must be shielded cables.
- The shields must be grounded on both the ends. Connections between systems must be of low impedance. High transient currents over the line shield resulting from differences in potential must be excluded.
- The design of the grounding connection with green/yellow cable must have a cross section of at least 4 mm<sup>2</sup>.

### 2.3 Installation

#### Installation

The device should be installed in an HF-proof housing or switch cabinet made of metal.

To ensure that heat generated in the device can dissipate into the environment, a space of 100 mm must be maintained around the device!

Eight hexagon nuts are used for assembly (depending upon execution of the equipment).



#### Tip!

The equipment may not be inserted lying, since otherwise convection at the radiator box is not ensured. Max. inclination to the rear 20°.



#### Caution!

Potential hazard of damaging the device!

Front-side protection type IP65 is only guaranteed if the seal is correctly seated in the front plate.

# T Technical data

## T1 Mechanical dimensions

Free spaces To ensure that heat generated in the device can dissipate into the environment, a space of 50 mm must be maintained around the device!

### T1.1 EPC G 1000 Outer/Mounting dimensions

Front plate	Width	318 mm
	Height	244 mm
Cutout dimensions	Width	303 mm
	Height	228 mm
Mounting depth		119,5 mm.
Weight		approx. 5,5 kg

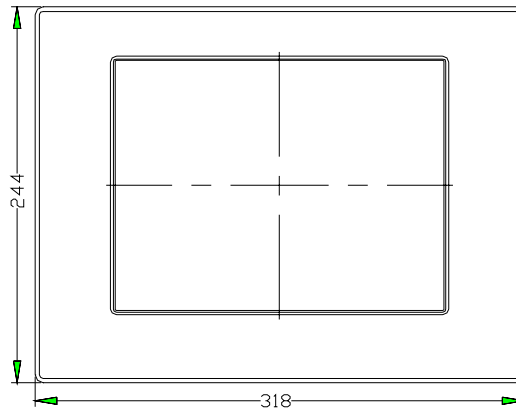

Type of attachment:  
With 6 retaining blocks made of aluminum or plastic with M5x30, DIN 914 set screws, with tip and hexagon socket, galvanized.

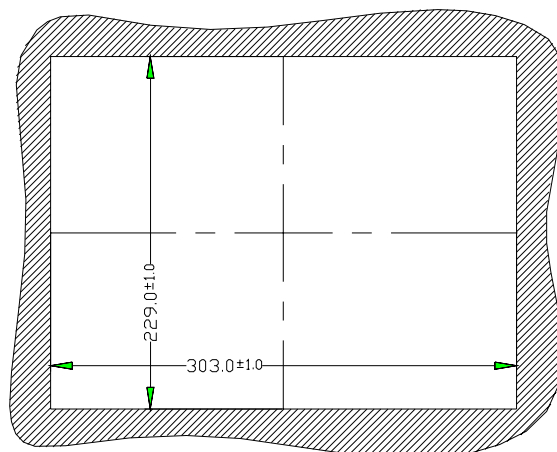

# T Technical data

## T1.2 EPC G 1000 Unit dimensions

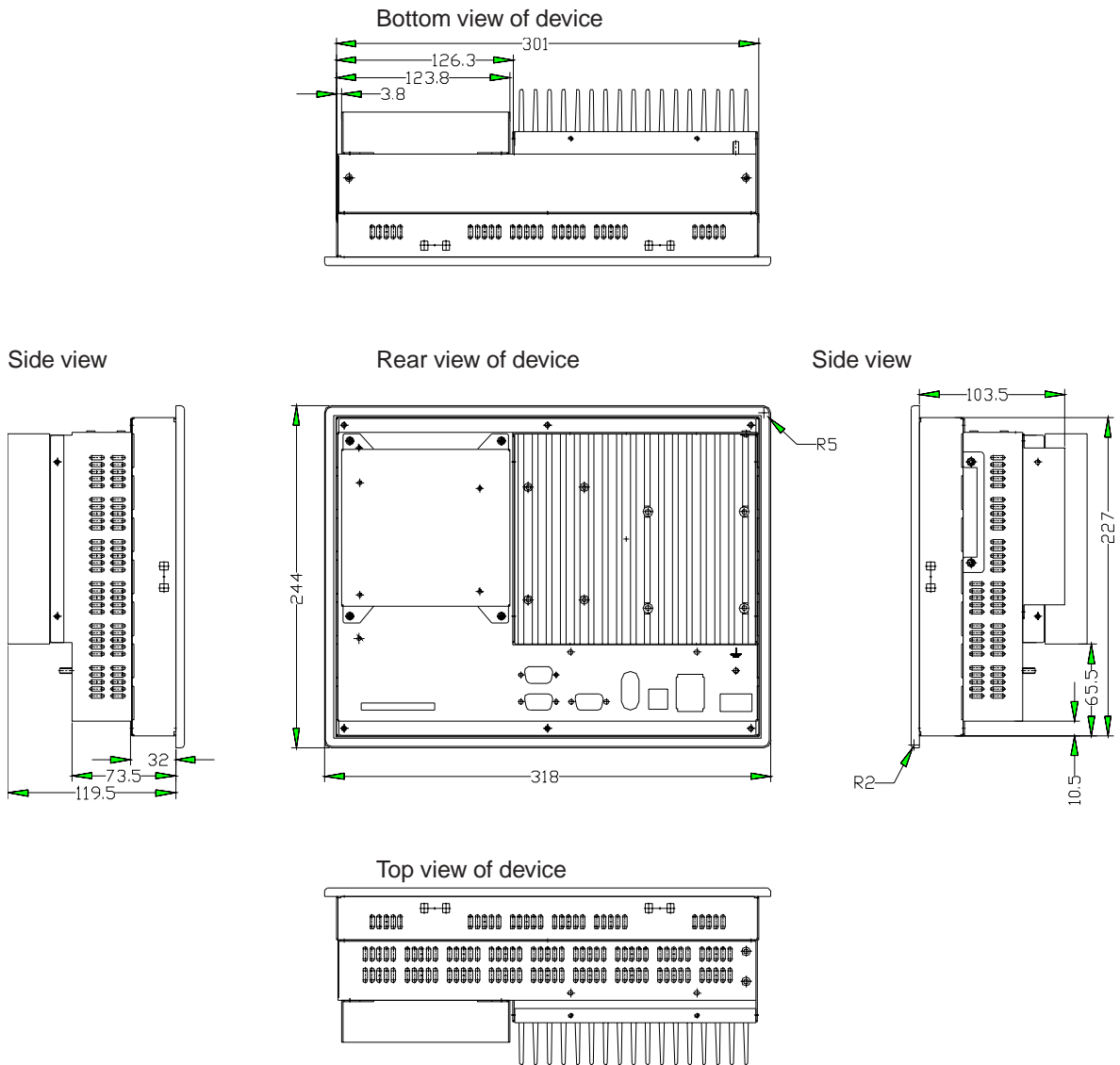

## T Technical data

### T1.3 EPC G 1200 Outer/Mounting dimensions

Front plate	Width	364 mm
	Height	296 mm
Cutout dimensions	Width	345 mm
	Height	277 mm
Mounting depth		111,5 mm.
Weight		approx. 6,0 kg

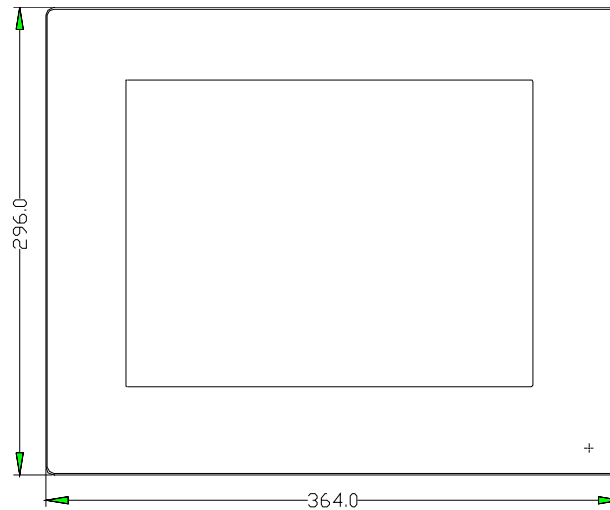

Type of attachment:  
8 pieces of nut/mother M4,  
8 pieces of wearing parts M4 and  
8 pieces of toothed washers M4.

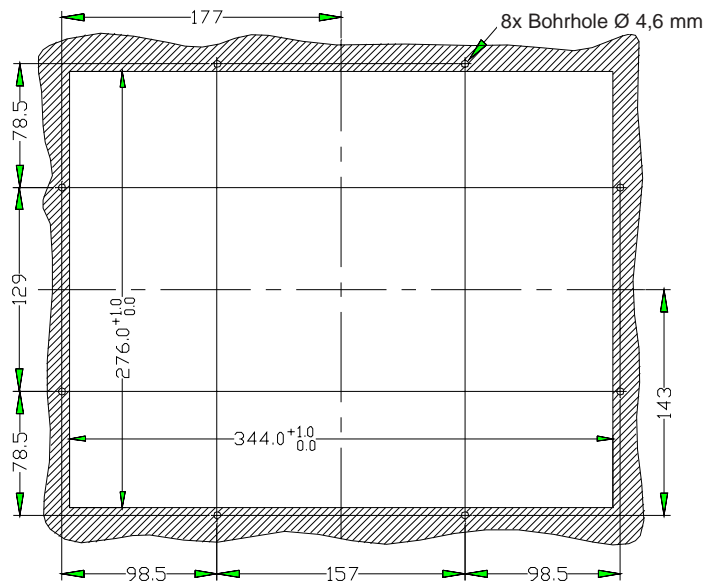

# T Technical data

## T1.4 EPC G 1200 Unit dimensions

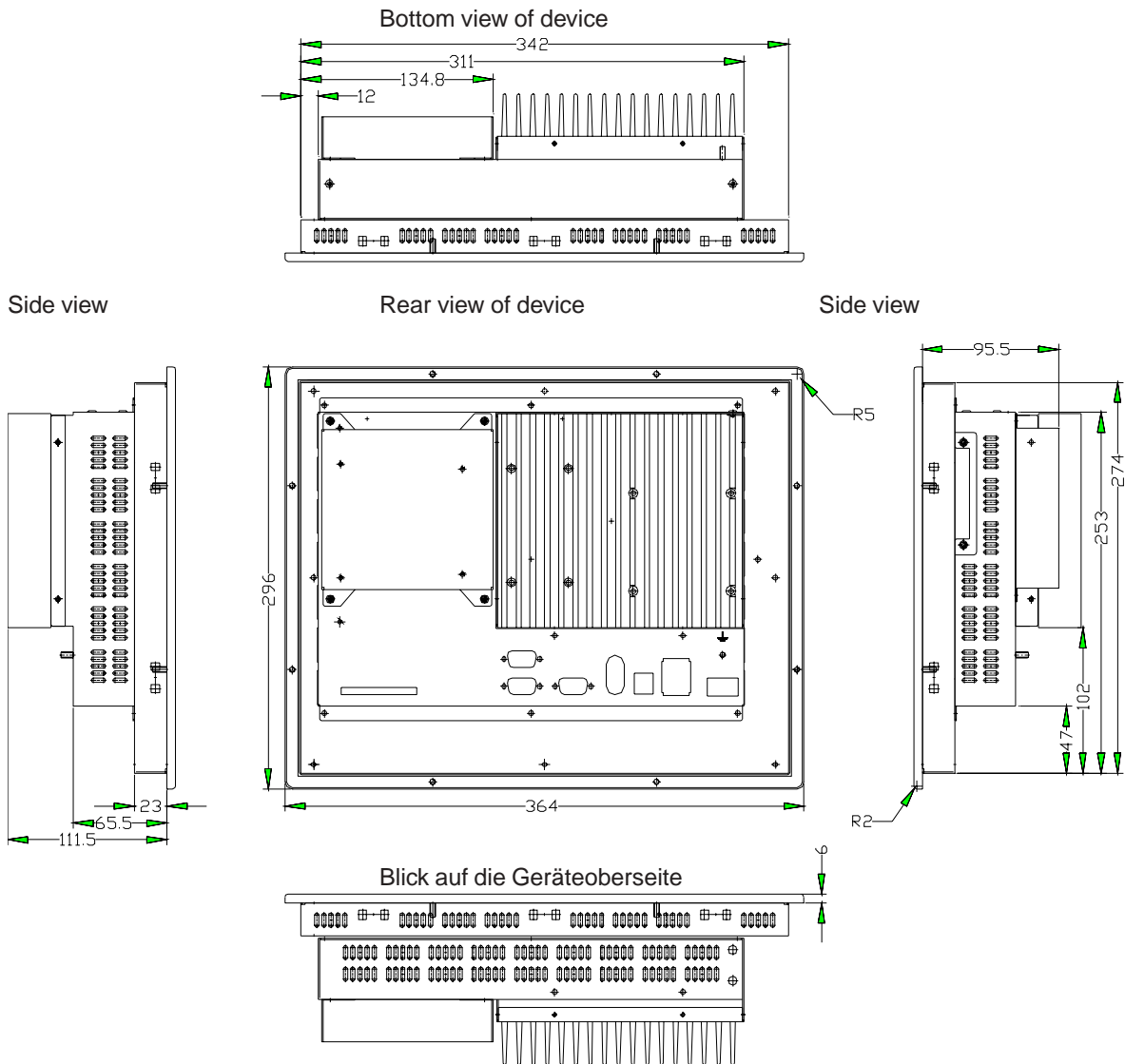

## T Technical data

### T1.5 EPC G 1500 Outer/Mounting dimensions

Front plate	Width	452 mm
	Height	357 mm
Cutout dimensions	Width	429 mm
	Height	334 mm
Mounting depth		124,5 mm
Weight		approx.76,5 kg

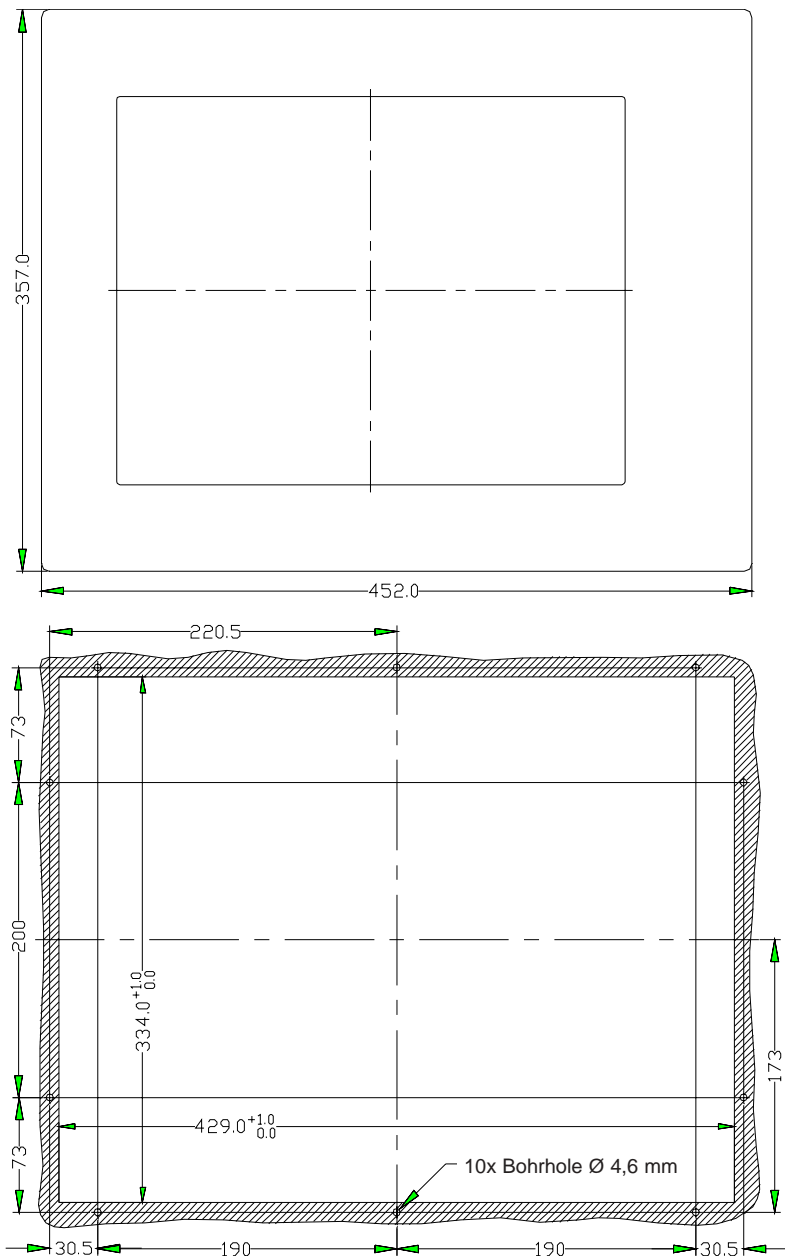

Type of attachment:  
10 pieces of nut/mother M4,  
10 pieces of wearing parts M4 and  
10 pieces of toothed washers M4.

# T Technical data

## T1.6 EPC G 1500 Unit dimensions

Bottom view of device

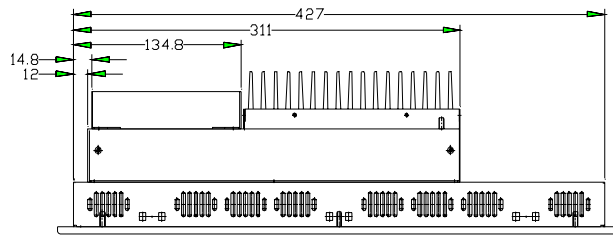

Side view

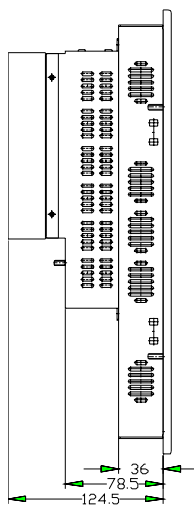

Rear view of device

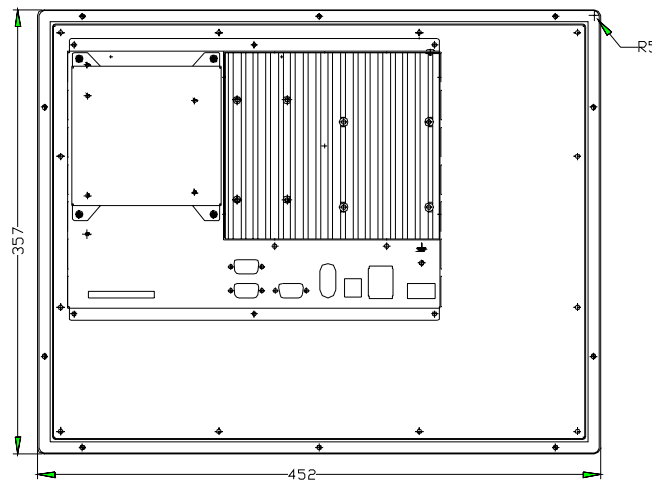

Side view

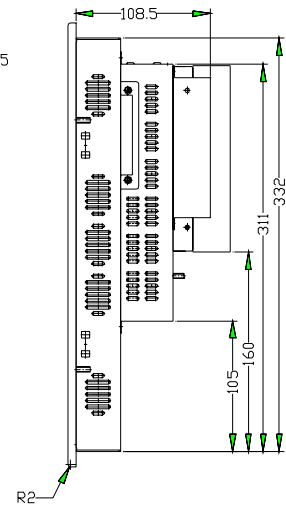

Top view of device

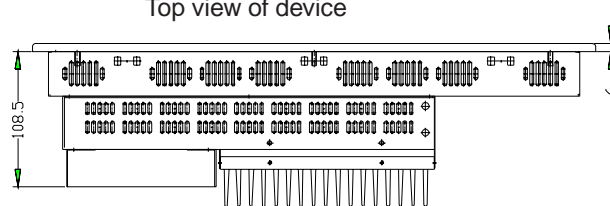



## T Technical data

### T1.7 EPC G 1500 V2A Outer/Mounting dimensions

Front plate	Width	407 mm
	Height	316 mm
Cutout dimensions	Width	393 mm
	Height	303 mm
Mounting depth		126 mm
Weight		approx. 7,0 kg

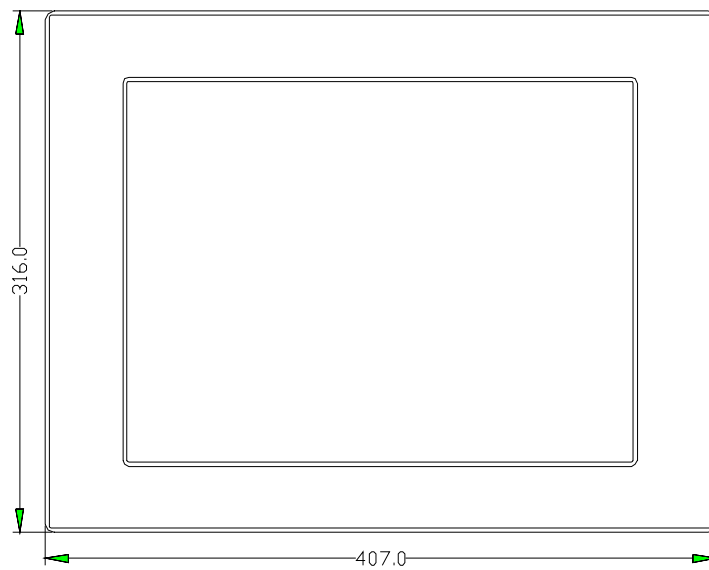

Type of attachment:  
With 8 retaining blocks made of aluminum or plastic with M5x30, DIN 914 set screws, with tip and hexagon socket, galvanized.

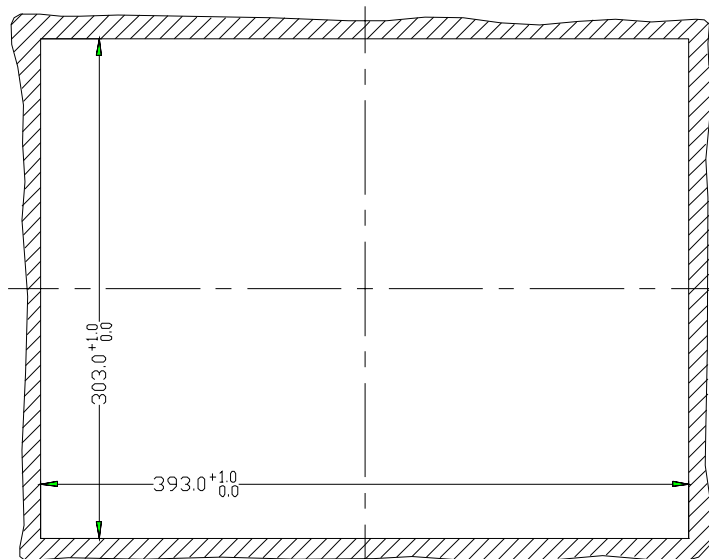

# T Technical data

## T1.8 EPC G 1500 V2A Unit dimensions

Bottom view of device

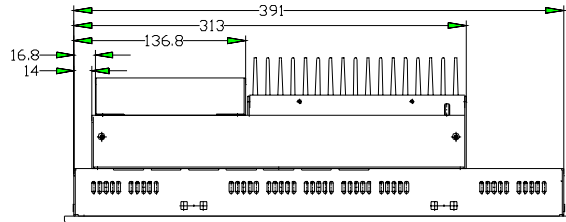

Side view

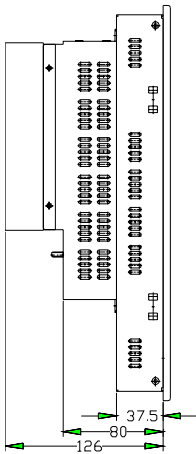

Rear view of device

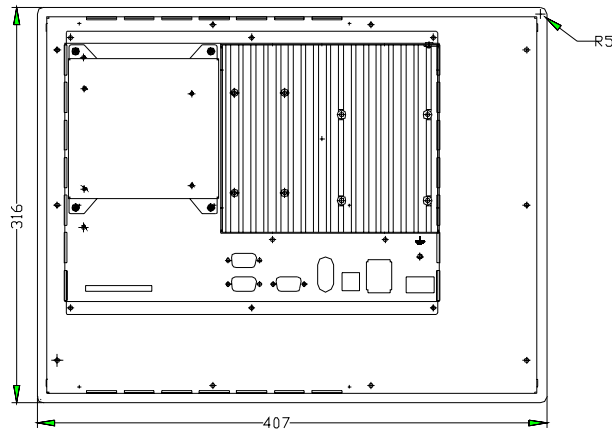

Side view

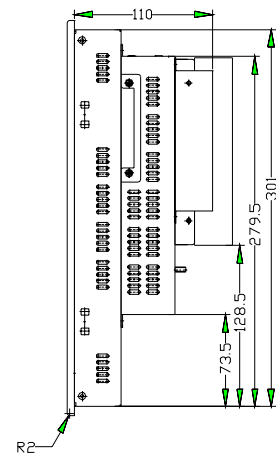

Top view of device

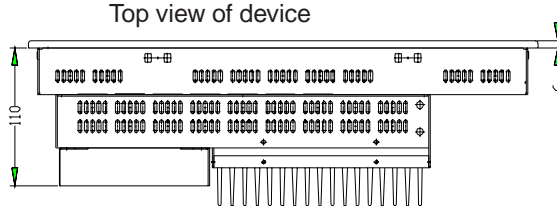

## T Technical data

### T1.9 EPC G 1000k Outer/Mounting dimensions

Front plate	Width	410 mm
	Height	266 mm
Cutout dimensions	Width	387 mm
	Height	243 mm
Mounting depth		120 mm.
Weight		approx. 6,5 kg

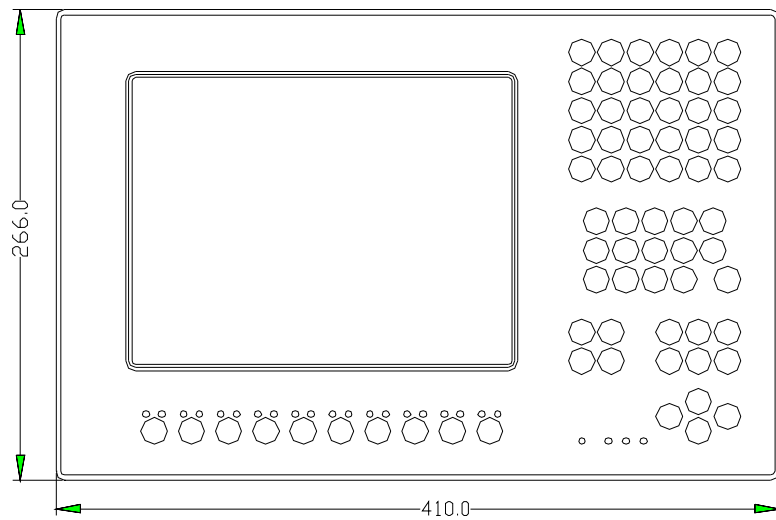

Type of attachment:  
With 8 retaining blocks made of aluminum or plastic with M5x30, DIN 914 set screws, with tip and hexagon socket, galvanized.

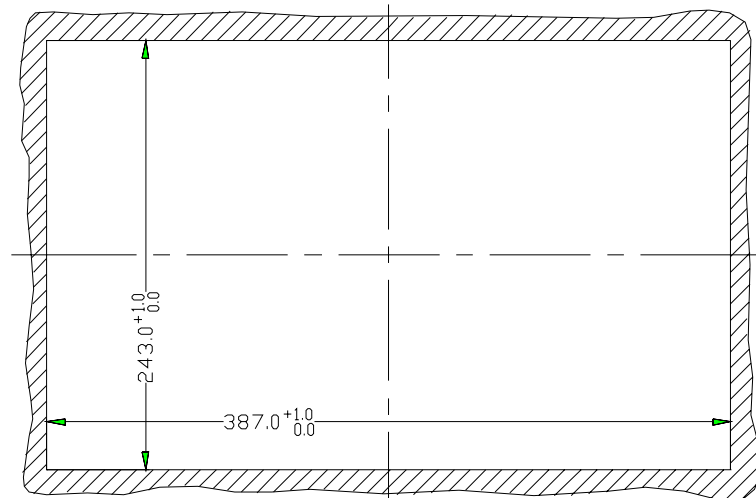

# T Technical data

## T1.10 EPC G 1000k Unit dimensions

Bottom view of device

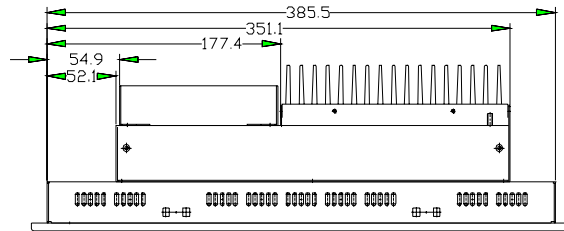

Side view

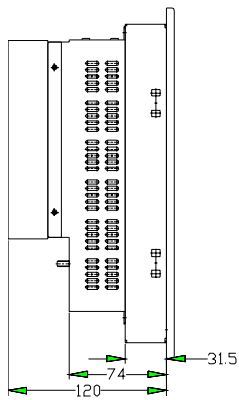

Rear view of device

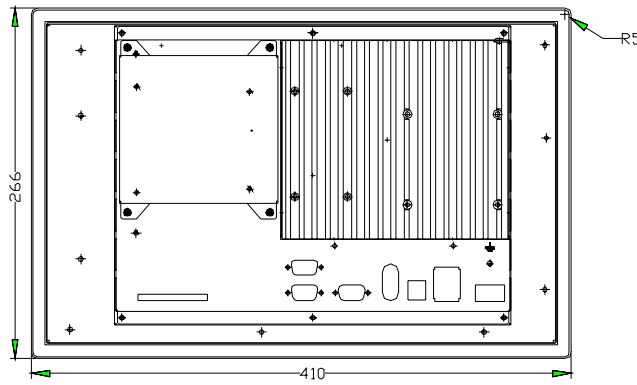

Side view

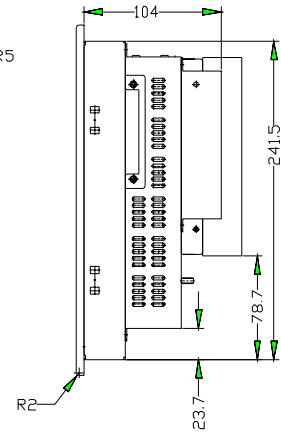

Top view of device

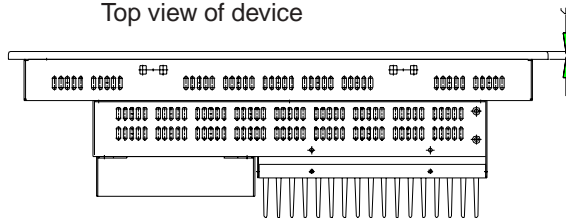

## T Technical data

### T1.11 EPC G 1200k Outer/Mounting dimensions

Front plate	Width	483 mm
	Height	310 mm
Cutout dimensions	Width	452 mm
	Height	292 mm
Mounting depth		114,5 mm
Weight		approx. 7,0 kg

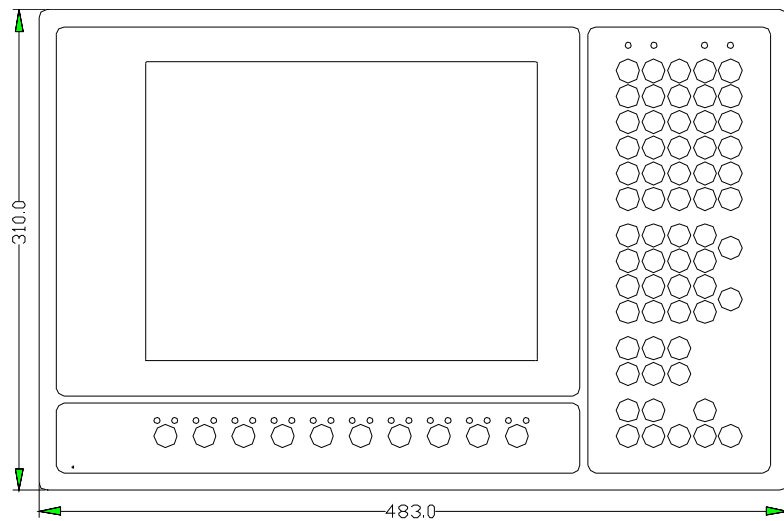

Type of attachment:  
With 10 retaining blocks made of aluminum or plastic with M5x30, DIN 914 set screws, with tip and hexagon socket, galvanized.

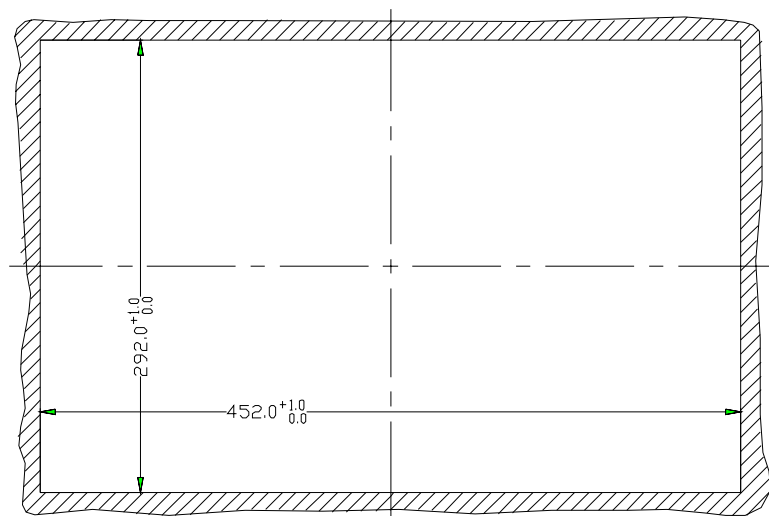

# T Technical data

## T1.12 EPC G 1200k Unit dimensions

Bottom view of device

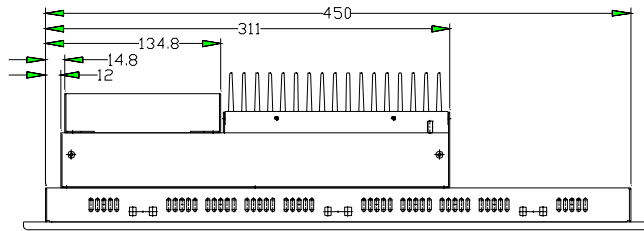

Side view

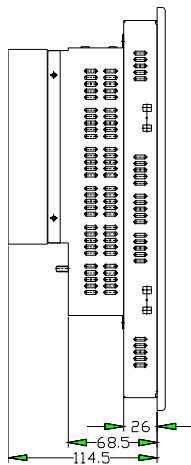

Rear view of device

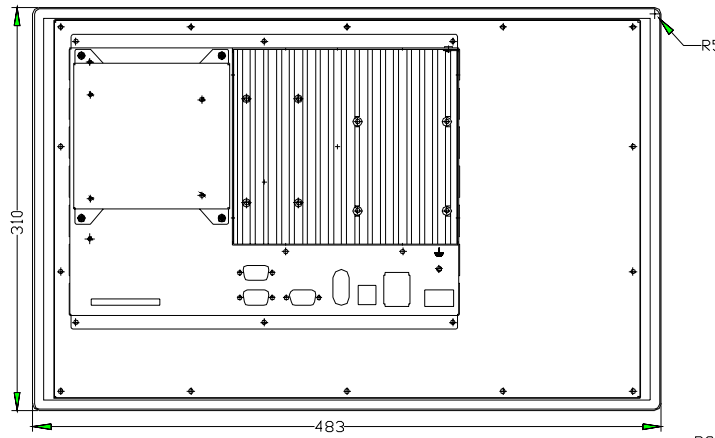

Side view

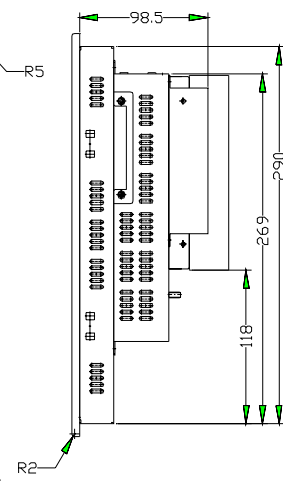

Top view of device

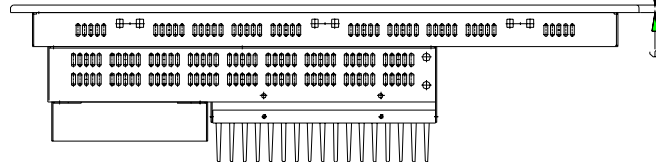

---

## T Technical data

### T2 Electrical data

Power supply	Operating voltage	24 V ± 15 %, protected against reverse polarity
	Power consumption	approx. 2 A
Display	EPC G 1000	
	TFT-Display 800 x 600 Pixel, 65536 colors, 10,4", CFL background illumination	
	EPC G 1200	
	TFT-Display 800 x 600 Pixel, 65536 colors, 12,1", CFL background illumination	
	EPC G 1500	
	TFT-Display 1024 x 768 Pixel, 16 Mio. colors, 15", CFL background illumination	
	Operating temperature range	0 ... 45 °C
Touch	Resistive	
CPU	Processor	1 GHz VIA C3
	Ram	256 MB
	Chipset	VIA PN 133T, integrated Graphic
	Memory card (external)	32 MB, 64 MB, 128 MB, 256 MB, 512 MB
	Slots	PC 104
Interfaces	Serial	2 x RS 232
	USB	2 x USB 1.1
	Keyboard/Mouse	2 x PS/2
	Network	2 x 10/100 Mbit
	Monitor	1 x VGA

---

## T Technical data

### T3 Ambient conditions

Ambient temperature	Operation	in case of vertical (standing) installation 0...45°C
	Storage	-20 ... 60° C
Humidity	Operation/Storage	10 ... 95 %, non-condensing
Resistance to vibration and shock	Sine	2 g, 10-500 Hz
	Shock	15 g, 11 ms
	Continuous shock	10 g, 16 ms
	Free fall	from a height of 1 m (in packaging)
Protection type	Front	IP 65
	Rear side	IP 20
EMC/CE	Interference resistance	European standard EN 61-000-6-2
	Interference emission	European standard EN 55022



---

## T Technical data

### T4 Interfaces

#### T4.1 Compact-FLASH-Slot

In its standard configuration, the EPC devices are equipped with a Compact FLASH slot based on CFA standard (Type 1).

Position of Compact-FLASH-Slots

1 Ejection lever



Caution!

Compact FLASH cards manufactured by SANDISK only may be used in combination with the EPC!

The compact FLASH card may be changed only when the device has been switched off !

#### T4.2 VGA/COM Interface

1 VGA-Port

2 COM 1 / 2



The serial interface has been assigned according to the PC XT/AT standard!

## T Technical data

### T4.3 Ethernet, USB, PS/2

- 1 Ethernet 1 / 2 (RJ45)
- 2 USB 1 / 2
- 3 PS2 Mouse/Keyboard

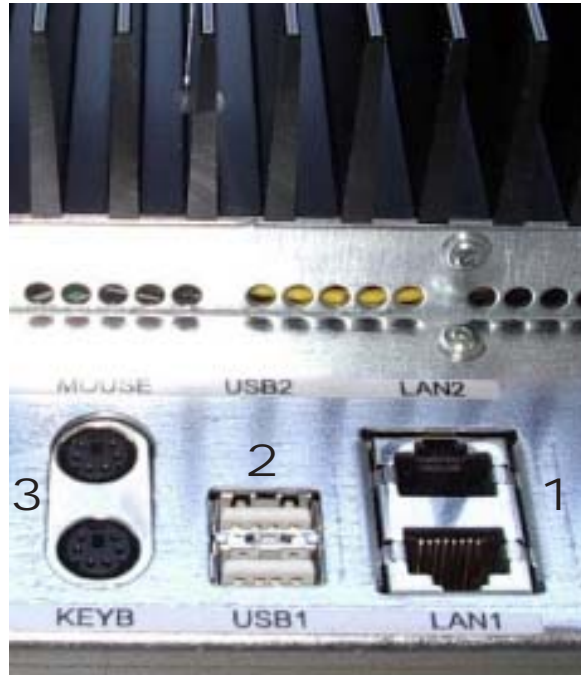

#### Caution!

The PS/2 mouse and PS/2 keyboard may be plugged or unplugged only when the device is switched off.

Otherwise these input devices are not recognized by the operating system!  
A maximum current of 100 mA may be drawn from the two USB interfaces!  
External USB devices which require a higher supply current have to provide this current themselves!

### T4.4 Cassette option

- 1 Bus module cassette (opt.)\*

\* Depending on the type of bus module, the interfaces can vary.  
If the bus module cassette has not been fitted, the rear side of the device is covered with a cover sheet.

