



Operating Instructions

Control Panels CP600

CP650-x, CP650-WEB-x

CP660-x, CP660-WEB-x

CP675-x, CP675-WEB-x

Content

Introduction	3
Before You Start	4
Safety Notices	4
Markups	4
Product Overview	5
Standards and Approvals	6
Product Identification	6
Technical Specifications	7
Environmental Conditions	7
Electromagnetic Compatibility (EMC)	8
Durability Information	9
Technical Data	10
Dimensions	11
Installation Environment	12
Applying the Rectangular Gasket.....	12
Installation Procedure	13
Connections	14
Serial Ports	14
Ethernet Port	16
Power Supply, Grounding and Shielding	17
AUX Port	19
Battery	20
Cleaning Faceplates	21
Getting Started	22

System Settings	23
Dedicated LED Indicators	25
Unpacking and Packing Instructions	26

Introduction

The operational guidelines described below is information which relates to the device, place of employment, transportation, storage, assembly, use and maintenance.

The products have been designed for use in an industrial environment in compliance with the 2004/108/CE directive.



The products have been designed in compliance with:

- EN 61000-6-4
- EN 55011 Class A
- EN 61000-6-2
- EN 61000-4-2, EN 61000-4-3, EN 61000-4-4, EN 61000-4-5, EN 61000-4-6

The installation of these devices into the residential, commercial and light-industrial environments is allowed only in the case that special measures are taken in order to get the conformity to IEC-61000-6.3.

The products are in compliance with the restrictions on Certain Hazardous Substances (RoHS) Directive 2002/95/EC.

This Operating Instruction describes the main features of the CP600 Control Panels. The Operating Instructions refers to the following models:

Picture	Type	Description
	CP650-x, CP650-WEB-x	Operator interface with TFT color 10.4" display touchscreen
	CP660-x, CP660-WEB-x	Operator interface with TFT color 12.1" display touchscreen
	CP675-x, CP675-WEB-x	Operator interface with TFT color 15" widescreen display touchscreen

Before You Start

Safety Notices



Indicates an imminent risk. It will lead to death or serious injury if not avoided.



Indicates a possible risk. It may lead to death or serious injury if not avoided.



Indicates a possible risk. It may lead to light or slight injury or material damage if not avoided.

Markups

- Enumeration.
- ✓ Precondition for an operation instruction or a description.
- Operation instruction with one step.
- 1. Operation instruction with several steps.
 - Result of an operation.



Helpful information with background information or an emphasized notice.



Application tips or other useful information and suggestions.

Product Overview

The Control Panels combine state-of-the-art features and top performance with an outstanding design. They are the ideal choice for all demanding HMI applications including factory and building automation.

These Control Panels have been designed to run the PB610 Panel Builder 600 software.

- PB610 Panel Builder 600 Runtime included. Full compatibility with PB610 Panel Builder 600.
- Full vector graphic support. Native support of SVG graphic objects. Transparency and alpha blending.
- Full object dynamics: Control visibility and transparency, move, resize, rotate any object on screen. Change properties of basic and complex objects.
- Truetype fonts.
- Multilanguage applications. Easily create and manage your applications in multiple languages to meet global requirements. Far East languages are supported. Tools available in PB610 Panel Builder 600 support easy third-party translations and help reducing development and maintenance costs of the application.
- Data display in numerical, text, bargraph, analog gauges and graphic image formats.
- Rich set of state-of-the-art HMI features: Data acquisition, alarm handling, scheduler and timed actions (daily and weekly schedulers, exception dates), recipes, users and passwords, e-mail and RSS feeds, rotating menus.
- Includes support for a wide range of communication drivers.
- Multiple drivers communication capability.
- Remote monitoring and control. Client-Server functionality.
- Simulation with PB610 Panel Builder 600.
- Powerful scripting language for automating HMI applications. Script debugging improves efficiency in application development.
- Rich gallery of vector symbols and objects.
- Project & page templates.
- Optional plug-in modules for fieldbus systems, networks and controllers.

Standards and Approvals

The Control Panels have been designed for installation and use in an industrial environment in compliance with the 2004/108/EC EMC Directive and with the following harmonized standards:

- EN 61000-6-4
- EN 61000-6-2

In compliance with the above regulations the products are CE marked.

The installation of these devices into the residential, commercial and light-industrial environments is allowed only in the case that special measures are taken in order to get the conformity to EN 61000-6-3.

Product Identification

The Control Panel products are identified by a product label. The label reports several information, including the model name, the part number, the power supply, the date of production (in the following format: ywww) and two barcodes. The first code is the version code, the second one the serial number (S.N.).

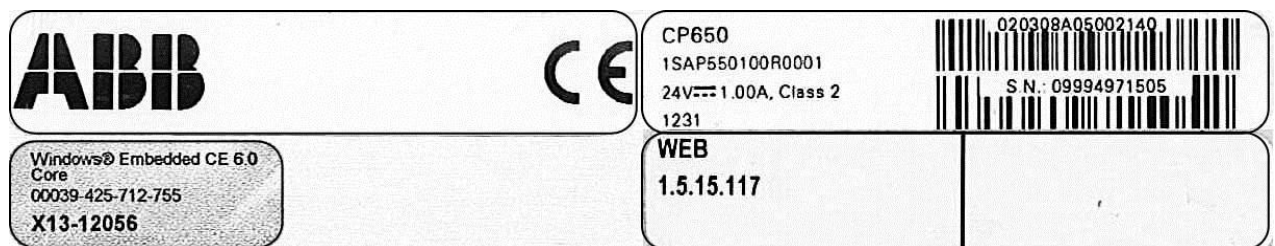

Example of product label

Information on type plate (example)	Description
CP650	Product type
1SAP550100R0001	Product part number
1231	ywww – week and year of production
09994971505	Serial number
020308A05002140	Version number of the product
WEB 1.5.15.117	Version number of the MicroBrowser (only valid for CP6xx-WEB)

Technical Specifications

Parameter	Value
Back-up battery	3V 50mAh Lithium, rechargeable, not user-replaceable, PANASONIC model VL2330
Fuse	Automatic

Environmental Conditions

Parameter	Value	According to
Operating temperature (vertical installation)	0 °C ... +50 °C	EN 60068-2-14
Storage temperature	-20 °C ... +70 °C	EN 60068-2-14
Operating and storage humidity	5 % ... 85 % RH not-condensing	EN 60068-2-30
Vibrations	5 Hz ... 9 Hz, 7 mm _{p-p} 9 Hz ... 150 Hz, 1 g	EN 60068-2-6
Shock	± 50 g, 11 ms, 3 pulses per axis	EN 60068-2-27
Protection class	IP66 front panel *	EN 60529
Touchscreen technology	Resistive	-
Touchscreen reliability	> 1 million operations	-

*) The front face of the Control Panel unit, installed in a solid panel, has been tested using conditions equivalent to the standards shown in the table above. Even though the Control Panel unit's level of resistance is equivalent to these standards, oils that should have no effect on the Control Panel can possibly harm the unit. This can occur in areas where either vaporized oils are present, or where low viscosity cutting oil are allowed to adhere to the unit for long periods of time. If the Control Panel's front face protection sheet becomes peeled off, these conditions can lead to the ingress of oil into the Control Panel and separate protection measures are suggested.

Also, if non-approved oils are present, it may cause deformation or corrosion of the front face. Therefore, prior to installing the Control Panel be sure to confirm the type of conditions that will be present in the Control Panel's operating environment.

If the installation gasket is used for a long period of time, or if the unit and its gasket are removed from the panel, the original level of the protection cannot be guaranteed. To maintain the original protection level, be sure to replace the installation gasket regularly.

Electromagnetic Compatibility (EMC)

Test executed on the 230 V AC side of the Power Supply (EN 61000-4-11).

Parameter	Value	According to
Emitted interference	Class A	EN 55011
Electrostatic	8 kV (air electrostatic discharge) 4 kV (contact electrostatic discharge)	EN 61000-4-2
Immunity to radiated radio-frequency	80 MHz ... 1 GHz, 10 V/m 1 GHz ... 2 GHz, 3 V/m 2 GHz ... 2.7 GHz, 1 V/m	EN 61000-4-3
Electromagnetic field	900 MHz, 10 V/m	EN V 50204
Immunity to conducted disturbances induced by radio-frequency field	0.15 MHz ... 80 MHz 10 V	EN 61000-4-3
Fast transient	2 KV power supply 1 KV signal lines	EN 61000-4-4
Input and output AC power ports	Level: 2 kV (L1/L2-PE) 1 kV (L1-L2)	EN 61000-4-5
Signal port	Level: 1 kV (line to earth)	
Immunity to conducted disturbances induced by radio-frequency field	0.15 ... 80 MHz, 10 V	EN 61000-4-6
Voltage dips, short interruptions and voltage variations immunity test	Port: AC mains. Level: 0 % / duration: 1 cycle and 250 cycles (50 Hz) or 300 cycles (60 Hz); 40 % / duration: 10 cycles (50 Hz) or 12 cycles (60 Hz); 70 % / duration: 25 cycles (50 Hz) or 30 cycles (60 Hz); Phase: 0°-180°	
Electrostatic discharge	8 kV in air	EN 61000-4-2
PC/Printer Port – COM2	RS-232, RS-485, RS-422 software configurable 300 ... 38400 baud	
PLC Port – COM1	RS-232, RS-485, RS-422 software configurable 300 ... 38400 baud	
AUX Port	Connector DB-9 pin female (functionality can be configured with an optional communication module)	
User memory	Flash 128 Mb	
Recipe memory	32 kB FRAM	
Hardware clock	Clock/calendar with back-up battery	
Accuracy RTC (at 25°C operating)	< 100 ppm	

Durability Information

Parameter	Value
Backlight service life (LED type)	MTBF value: 40,000 hrs (time of continuous operation until the brightness of the backlight reaches 50 % when the surrounding temperature reach 25 °C), see ¹
Backlight service life (CCFL type)	MTBF value: 50,000 hrs or more (time of continuous operation until the brightness of the backlight reaches 50 % when the surrounding temperature is 25 °C), see ¹
Battery lifetime	10 years if the surrounding temperature is 25 °C 5 years if the surrounding temperature is 40 °C
Front foil silk screen (without directly expose to sunlight or UV ray)	10 years if the surrounding temperature is 25 °C
UV Resistance	Indoor applications: After 300 hrs cycled humidity in QUV, some yellowing and brittleness may be present.
Touch panel (resistive film, analog)	1,000,000 or more of activations, see ²

¹ Extended use in environments where the surrounding air temperature is 40 °C or higher may degrade backlight quality/reliability/durability.

² Solvent resistance:

Contact for ½ hour at 21 °C, no visible effect: Acetone, Butyl Cellosolve, Cyclohexanone, Ethyl Acetate, Hexane, Isopropyl Alcohol, MEK, Methylene Chloride, Toluene, Xylene

Contact for 24 hours at 49 °C, no visible effect: Clorox, Coffee, Downy, Fantastik, Formula 409, Ketchup, Lemon Juice, Mr. Clean, Mustard (slight yellow stain), Spray 'N Wash, Tea, Tomato Juice, Top Job, Wisk

Technical Data

Model	CP650(-WEB)-x	CP660(-WEB)-x	CP675(-WEB)-x
Display/Backlight	TFT Color / LED	TFT Color / CCFL	TFT Color / CCFL
Colors	64 K	64 K	64 K
Resolution	800 x 600	800 x 600	1024 x 768
Diagonal (inches)	10.4"	12.1"	15"
Dimming	Yes	Yes	Yes
Touchscreen	Yes	Yes	Yes
User memory flash	128 MB	128 MB	128 MB
Flash card option	-	-	-
Recipe memory	Yes. Flash memory storage limited only by available memory	Yes. Flash memory storage limited only by available memory	Yes. Flash memory storage limited only by available memory
PLC Port – COM1	RS-232, RS-485, RS-422	RS-232, RS-485, RS-422	RS-232, RS-485, RS-422
Programming/printer port – COM2	RS-232, RS-485, RS-422	RS-232, RS-485, RS-422	RS-232, RS-485, RS-422
Aux port (optional fieldbus/Ethernet)	Yes	Yes	Yes
Ethernet programming	Yes	Yes	Yes
Ethernet port	10/100 Mbit/s	10/100 Mbit/s	10/100 Mbit/s
USB port	Host interface, version 2.0	Host interface, version 2.0	Host interface, version 2.0
Graphic	Yes	Yes	Yes
Video input option	-	-	-
Trend acquisition and display	Yes	Yes	Yes
Battery	Rechargeable	Rechargeable	Rechargeable
Real-time clock	Yes	Yes	Yes
Password	Yes	Yes	Yes
Alarms	1024	1024	1024
Event list	Yes, configurable	Yes, configurable	Yes, configurable
Voltage	18-30 V DC	18-30 V DC	18-30 V DC
Current rating (at 24 V DC)	0.75 A	1.05 A	1.05 A
Weight	2 kg	2.8 kg	3.4 kg

Dimensions

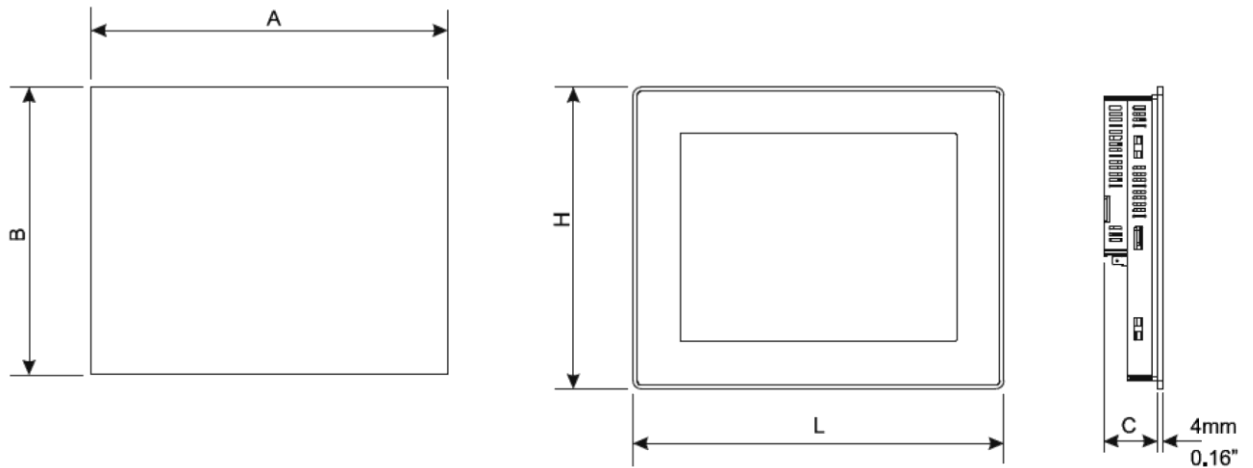

Model	A		B		C		H		L	
	mm	inches	mm	inches	mm	inches	mm	inches	mm	inches
CP650(-WEB)-x	276	10.86"	221	8.70"	42	1.65"	232	9.13"	287	11.30"
CP660(-WEB)-x	326	9.30"	256	10.1"	42	1.65"	267	10.51"	337	13.26"
CP675(-WEB)-x	381	15"	296	11.65"	46	1.82"	307	12.1"	392	15.43"

Model	CSD: Minimum compass safe distance of standard compass		CSD2: Minimum compass safe distance of steering compass, standby steering compass and emergency compass	
	mm	inches	mm	inches
CP650(-WEB)-x	400	15.74"	250	9.84"
CP660(-WEB)-x	500	19.68"	300	11.81"
CP675(-WEB)-x	650	25.60"	400	15.74"

Installation Environment

The equipment is not intended for continuous exposure to direct sunlight. This might accelerate the aging process of the front panel film.

The equipment is not intended for installation in contact with corrosive chemical compounds. Check the resistance of the front panel film to a specific compound before installation.

Do not use tools of any kind (screwdrivers etc.) to operate the keyboard of the panel or the touchscreen.

In order to meet the front panel protection classifications, proper installation procedure must be followed:

- ✓ The borders of the cutout must be flat.
- ✓ The cutout for the panel must be of the dimensions indicated in this manual.
- Screw up each fixing screw until the plastic bezel corner get in contact with the panel.

The IP66 is guaranteed only if:

- Maximum deviation from the plane surface to the cut-out: Ø 0.5 mm
- Thickness of the plate the equipment is mounted: 1.5 mm to 6 mm
- Maximum surface roughness where the gasket is applied: Ø 120 µm

Applying the Rectangular Gasket

- Apply the gasket on the rear of the frame.

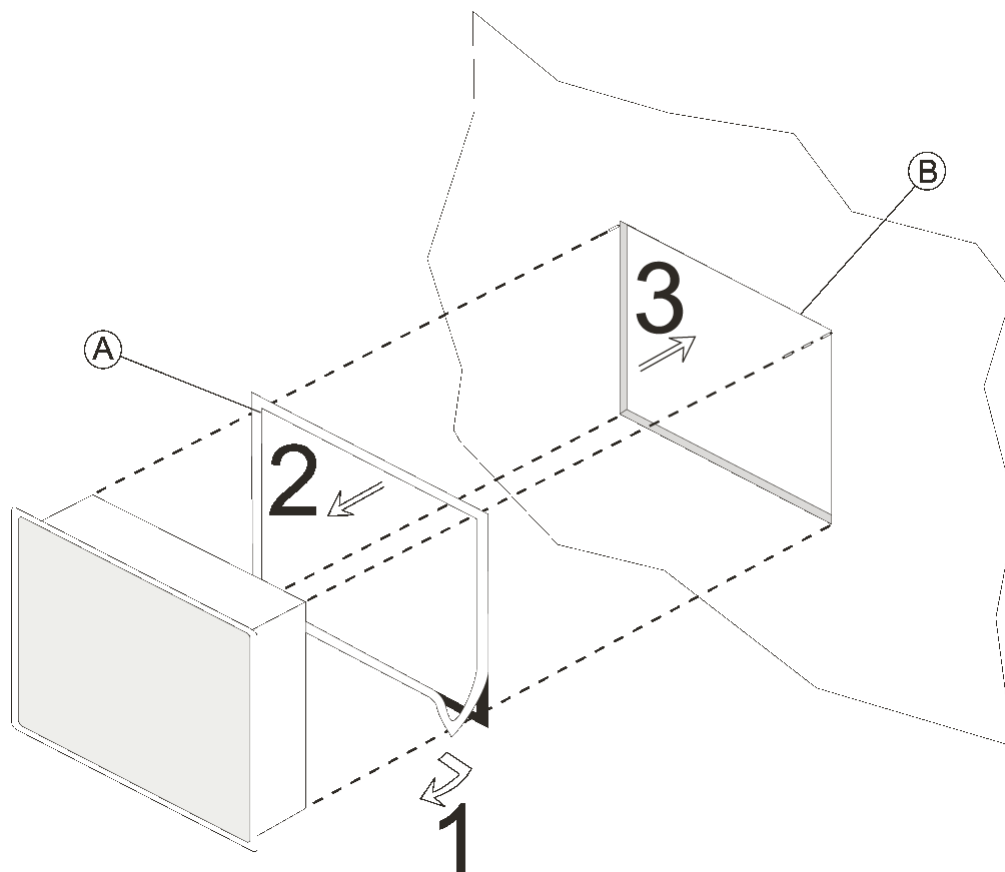

A Gasket **B** Installation cut-out

Installation Procedure

→ Place the fixing brackets.

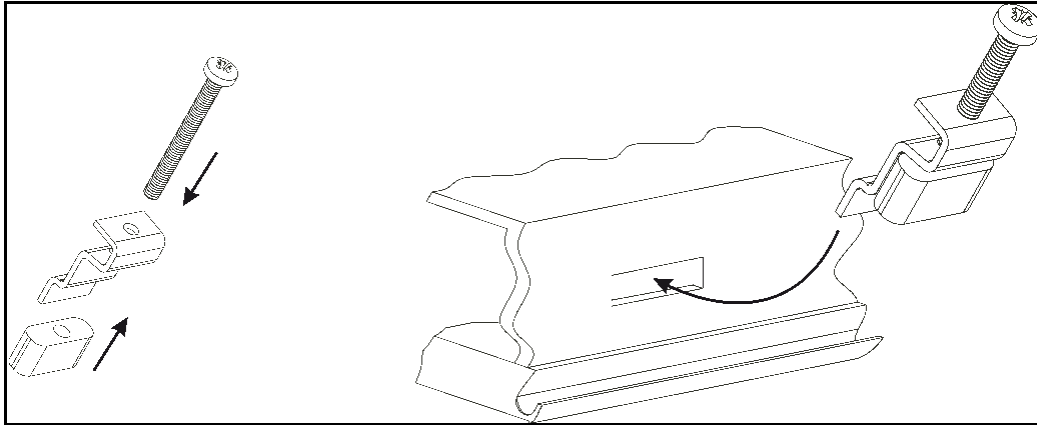

CAUTION!

Screw each fixing screw until the bezel corner gets in contact with the panel.

Connections

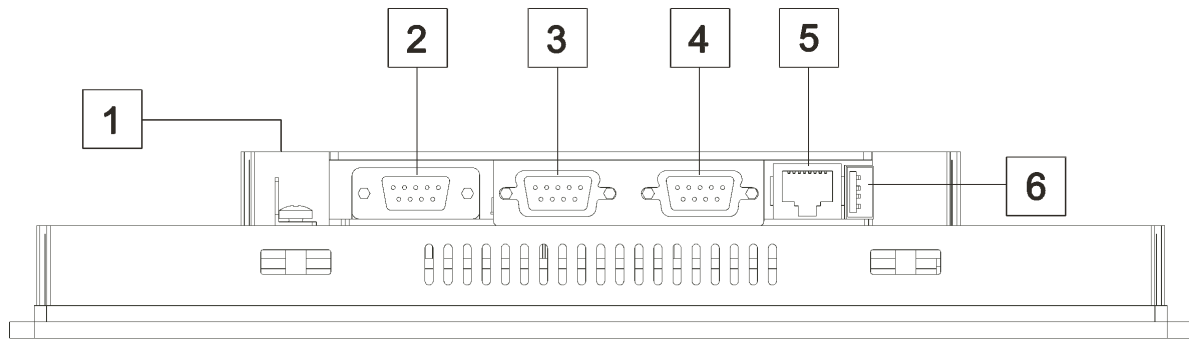

Connections of the Control Panel

- | | | |
|------------|--------------------------|-----------------|
| 1 Power | 3 PLC port – COM1 | 5 Ethernet port |
| 2 Aux port | 4 PC/printer port – COM2 | 6 USB port for |
- 

Serial Ports

The serial ports COM1 and COM2 can be used to communicate with the PLC or with another type of controller.

Different electrical standards are available for the signals in the PLC port connector: RS-232, RS-422, RS-485. The used cable selects the appropriate signals.



NOTE

It is always necessary to use the correct cable type to connect on the PLC. If the proper cable is not used, communication with the PLC will not be possible.

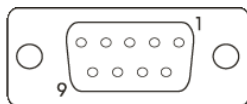

The connector is a DB-9 pin female.

Pin	Description	Pin	Description	Pin	Description
1	GND	4	RX/CHB-	7	CTS/CHB+
2		5		8	RTS/CHA+
3	TX/CHA-	6	+5 V output	9	

Communication Cable

The communication cable must be chosen for the type of device being connected.

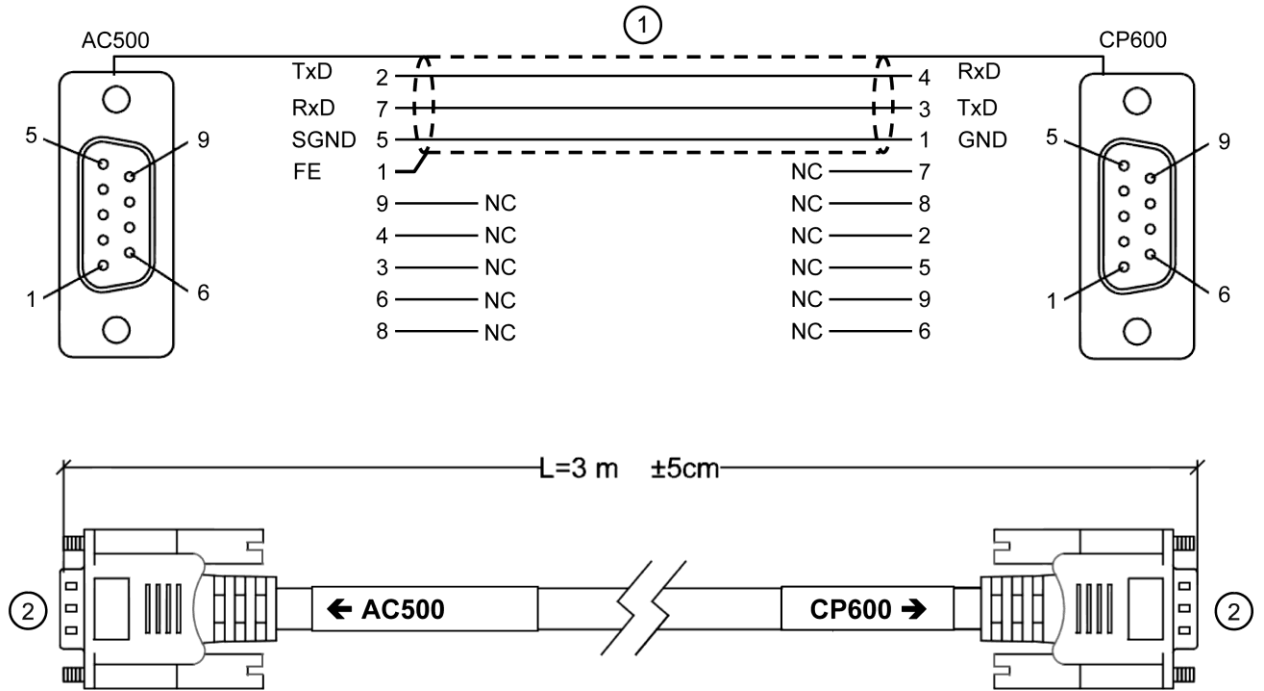

Connection to an AC-500 with the TK681 CP600-AC500 RS232 communication cable

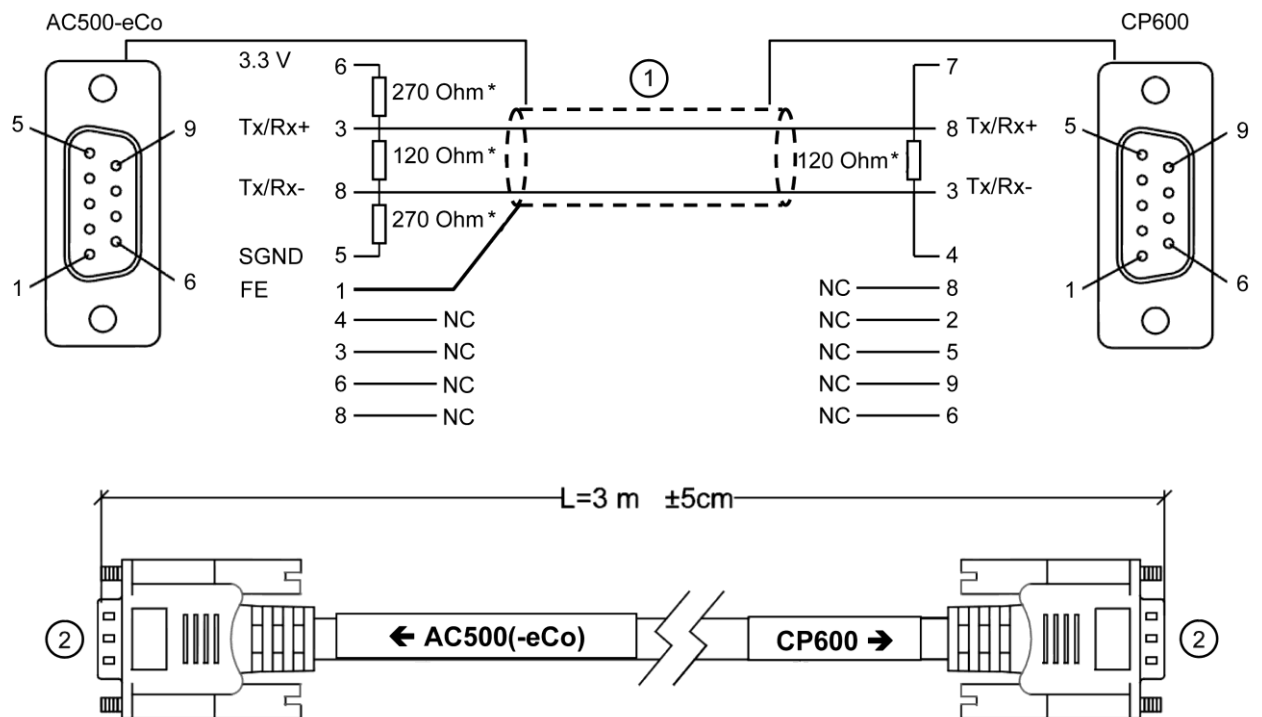

Connection to an AC-500(-eCo) with the TK682 CP600-AC500(-eCo) RS485 communication cable

- 1 Shield 2 SubD9 male

Ethernet Port

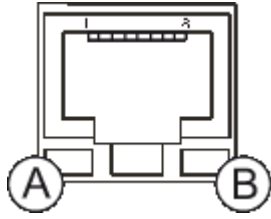

Ethernet Port

A OFF: No activity
BLINKING: Activity

B ON: Valid link has NOT been detected
OFF: Valid link has been detected

Pin	Description	Pin	Description	Pin	Description	Pin	Description
1	TX OUT +	3	RX OUT +	5		7	
2	TX OUT -	4		6	RX OUT -		

Power Supply, Grounding and Shielding

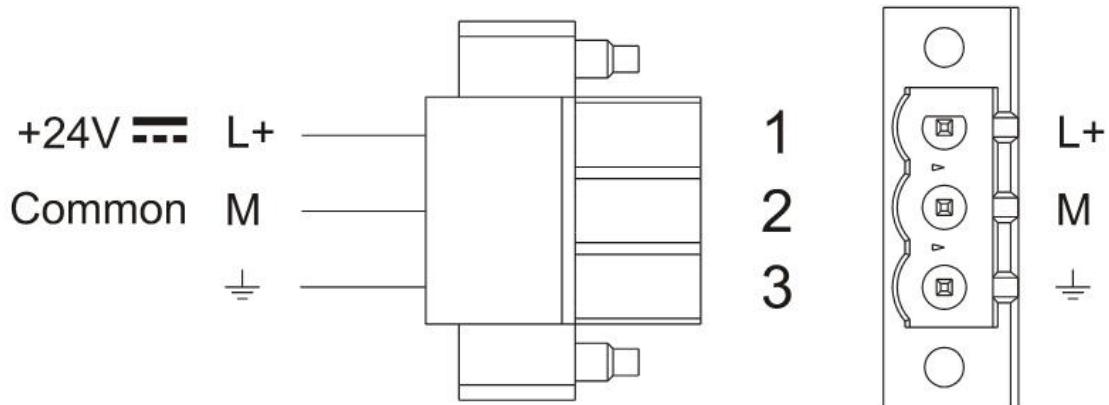

DC Power Connector, Female - R/C Terminal Blocks (XCPR2), manufactured by Weidmüller Inc.,
Cat. No. BLZ 5.08, torque 4.5 lb-in



NOTE

Ensure that the power supply has enough power capacity for the operation of the equipment.

The unit must always be grounded to earth. Grounding helps limit the effects of noise due to electromagnetic interference on the control system.

1. Do the earth connection using either the screw or the faston terminal located near the power supply terminal block. A label helps identify the ground connection.
2. Connect to ground the terminal 3 on the power supply terminal block.
3. The power supply circuit may be floating or grounded. In the latter case, connect to ground the power source common as shown in the figure below with a dashed line.

When using the floating power scheme, note that the panel internally connects the power common to ground with a 1 MΩ resistor in parallel with a 4,7 nF capacitor.

The power supply must have double or reinforced insulation.

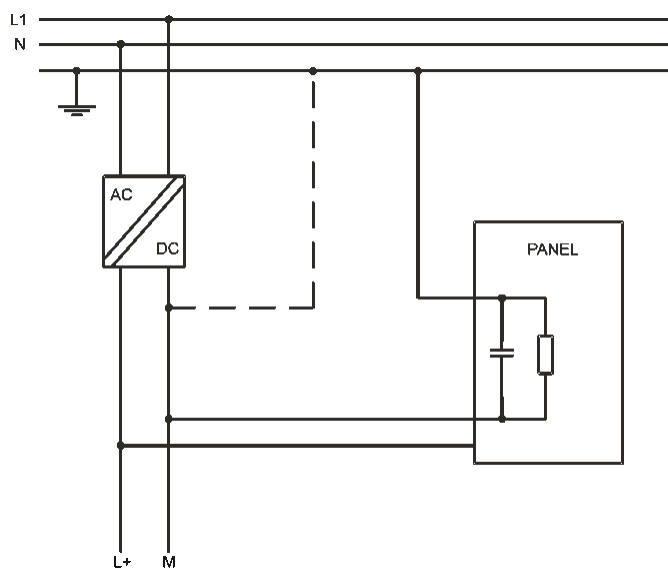

Suggested wiring for the power supply.

All the electronic devices in the control system must be properly grounded. Grounding must be performed according to applicable regulations.

AUX Port

The AUX port is a communication port specially designed for industrial network communication. The AUX port connector is a 9 pin D sub type. The functionality of the AUX port depends on the optional Communication Module which is plugged into the unit.



NOTE

The pin assignment of the AUX port connector is described in the manual of the Communication Module.



WARNING!

Do not plug the Communication Module and the ETAD adapter when power is applied to the operator panel.

1. Open the housing.

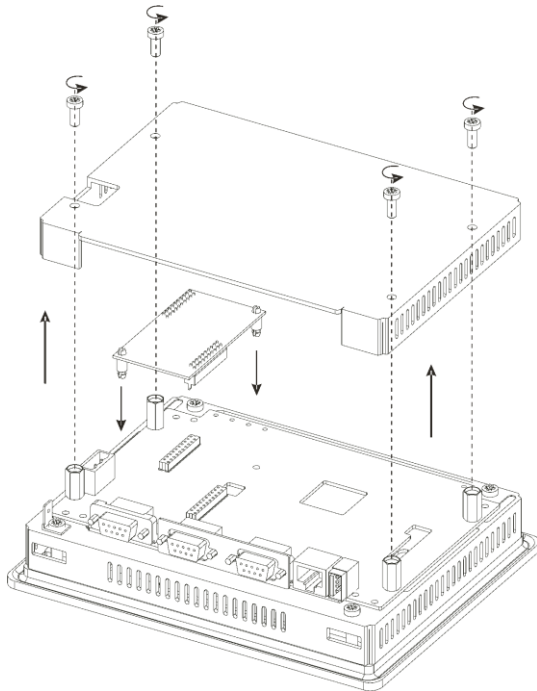

2. Insert the Communication Module pressing simultaneously on the four corners.

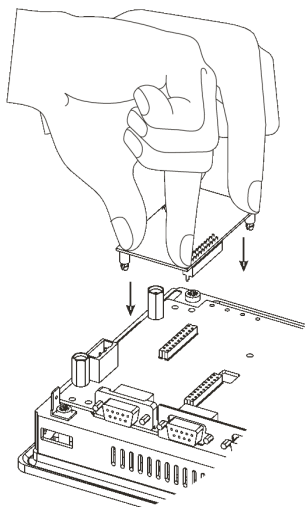

Battery

The Control Panels are equipped with a rechargeable lithium battery, not user-replaceable.

The battery maintains the hardware real-time clock (date and time).

Charging the Battery

- At first installation recharge the battery for 48 hours.
 - ▶ When the battery ① is charged, it assures a period of 3 month of data back-up at 25 °C.

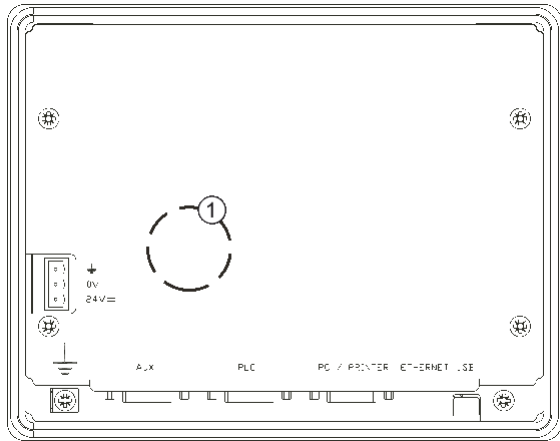

Recycling and Disposal



The battery must not be disposed as unsorted domestic waste.

- Dispose the battery according to the local regulations.

Cleaning Faceplates

The equipment must be cleaned only with a soft cloth and neutral soap product. Do not use solvents.

Getting Started

The Control Panels must be programmed with the programming package PB610 Panel Builder 600.

The Control Panels are programmed via the Ethernet interface.

- ✓ The Control Panel must be in configuration mode to be programmed.
- To program a Control Panel connect the Control Panel to a PC running PB610 Panel Builder 600 software package.

The software package PB610 Panel Builder 600 is a Windows™ application and must be properly installed. The Windows™ environment is not included in the software package PB610 Panel Builder 600 and must already be installed on the PC.

PB610 Panel Builder 600 uses the PC Ethernet interface to communicate with the target device.

- Make sure that the proper firewall policy is configured in order to allow PB610 Panel Builder 600 to access the network.

The version of the Panel Builder used must be compatible with the PB610 Panel Builder 600 Runtime version installed on the Control Panel to be programmed. Check with technical support for more information on compatibility between firmware and programming software.

System Settings

The Control Panels have a system settings tool to allow basic and preliminary settings to the unit.

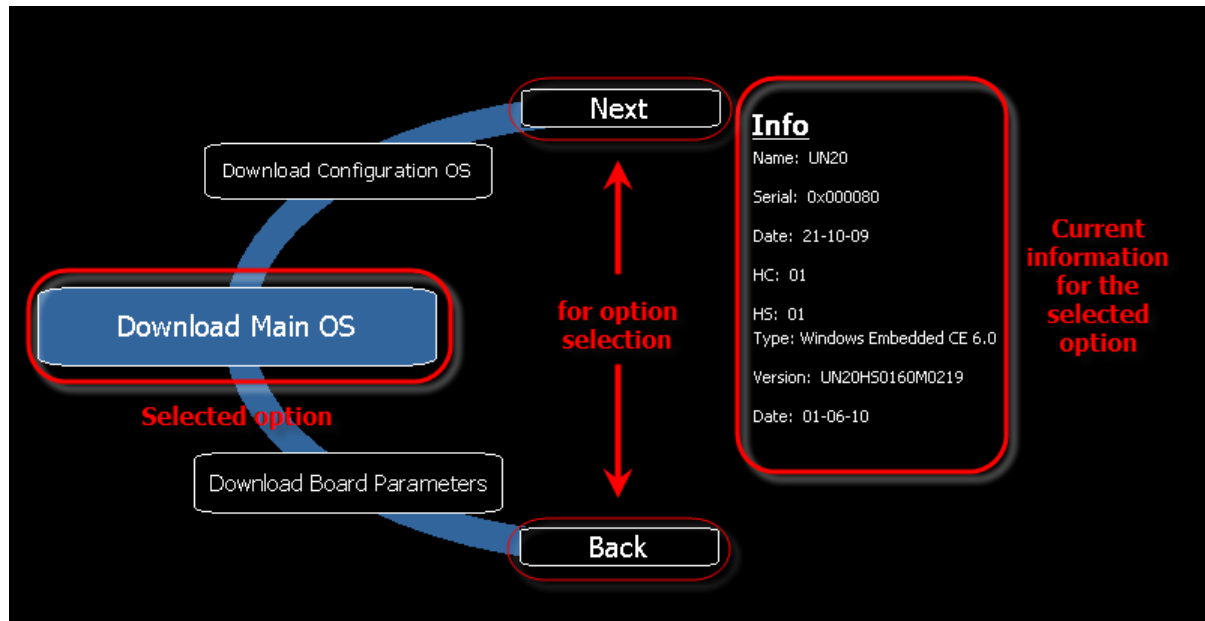

System settings tool

The system settings tool is a rotating menu.

- Use the navigation buttons **Next** and **Back** to scroll between the available options.
 - On the left side the selected component and function are highlighted.
 - On the right side, on the “Info” pane, the information about the selected option is shown. For example the version of the Main OS component.

The system settings tool has two operating modes: User Mode and System Mode. The difference between them is the number of available options.

System settings in User Mode is activated from the contextual menu, accessible by clicking and holding on the touchscreen for a few seconds. Default holding time is 2 sec. This is a runtime parameter that could have been changed. Please contact your panel supplier for any additional information or use the System Mode activating it with the tap-tap special procedure.

Tap-tap consists in a high frequency sequence of touch activations by simple means of the finger tapping the touchscreen performed during the power up and started immediately after the panel is powered.

User Mode

User Mode is the simplest possible interface where a generic user can get access to the basic settings of the panel:

- Calibrate Touch: allows to calibrate the touchscreen interface
- Network: allows to change the options of the panel on-board network card
- Time: allows to change the panel RTC options, including time zone and DST
- Display settings: automatic backlight turnoff and brightness adjustment
- BSP settings: allows to check the BSP (Board Support Package) version (example 2.37), check the operating hours timers for the unit and separately for the backlight, enable/disable the buzzer, enable/disable the use of the “low battery” front LED indicator

System Mode

- System Mode is the complete interface of the system settings tool where all options are available. Additionally to the options of the User Mode the following options are available:
- Format Flash: allows to format the internal panel flash disk
- Resize Image Area: allows to resize the flash portion reserved to store the splash screen image displayed by the unit at power up; default settings are normally ok for all the units
- Download Configuration OS: allows to check current version and upgrade the back-up operating system, see below in the next chapter for additional details
- Download Main OS: allows to check current version and upgrade the main operating system, see below in the next chapter for additional details
- Download Splash Image: allows changing the splash screen image displayed by the unit at power up; the image should be provide in a specific format. We suggest to update Splash Screen Image directly from Studio software which supports this feature starting from V 1. 50
- Download Bootloader: allows to check current version of the system boot loader and to upgrade it, see below for additional details
- Download Main FPGA: allows to check current version and upgrade the main FPGA firmware, see below for additional details
- Download Safe FPGA: allows to check current version and upgrade the back-up (safe) copy of the FPGA Firmware, see below for additional details
- Download System Supervisor: allows to check current version and upgrade the system supervisor firmware responsible for RTC and power supply handling, see below for additional details

Dedicated LED Indicators

There is one LED in the upper left part of the front below the red stripe. The meaning of the LED indicator is explained in the following table:

LED color	Status	Meaning
Green	On	Normal operation
	Blinking	Communication error or alarm requires acknowledgement
Red	On	Hardware fault
	Blinking	Battery low

Unpacking and Packing Instructions

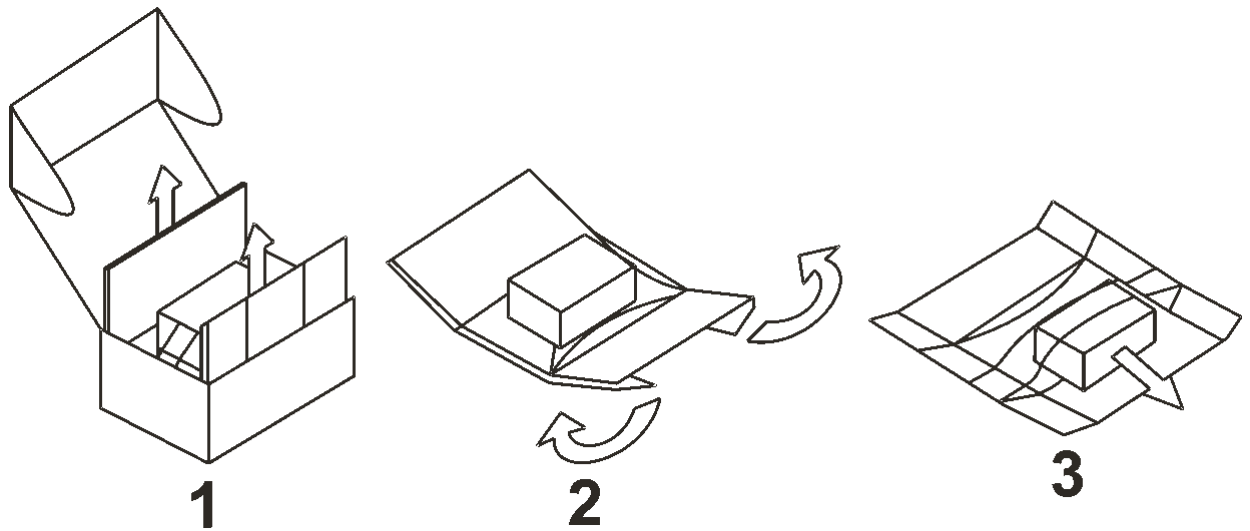

→ To repack the unit follow the instructions backwards.

Contact us

ABB Automation Products GmbH

Wallstadter Str. 59

68526 Ladenburg, Germany

Phone: +49 62 21 701 1444

Fax: +49 62 21 701 1382

E-Mail: plc.sales@de.abb.comwww.abb.com/plc**Note:**

We reserve the right to make technical changes or modify the contents of this document without prior notice. With regard to purchase orders, the agreed particulars shall prevail. ABB AG does not accept any responsibility whatsoever for potential errors or possible lack of information in this document.

We reserve all rights in this document and in the subject matter and illustrations contained therein. Any reproduction, disclosure to third parties or utilization of its contents – in whole or in parts – is forbidden without prior written consent of ABB AG.

© Copyright 2011-2013 ABB.

All rights reserved.

Subject to alterations.