

Operating Instructions

Control Panels CP405 Control Panels CP408

Contents

Introduction	2
Before You Start	3
Safety Notices	3
Markups	3
Product Overview	4
Standards and Approvals	5
Product Identification	5
Technical Specifications	6
Environmental Conditions	6
Electromagnetic Compatibility (EMC)	7
Durability Information	8
Technical Data	9
Dimensions	10
Installation Environment	12
Installation Procedure	12
Connections	13
Serial Port	14
Communication Cables	15
Power Supply, Grounding and Shielding	16
Battery	17
Cleaning Faceplates	18
Getting Started	19
Panel Setup	20

Introduction

The operational guidelines described below is information which relates to the device, place of employment, transportation, storage, assembly, use and maintenance.

The Control Panels have been designed for installation and use in an industrial environment in compliance with the 2004/108/EC EMC Directive.



The products have been designed in compliance with:

EN 61000-6-4	EN 55022 Class A
EN 61000-6-2	EN 61000-4-2
	EN 61000-4-3
	EN 61000-4-4
	EN 61000-4-5
	EN 61000-4-6
	EN 61000-4-8

The installation of these devices into the residential, commercial and light-industrial environments is allowed only in the case that special measures are taken in order to get conformity to EN 61000-6-3.

The products are in compliance with the Restrictions on Certain Hazardous Substances (RoHS) Directive 2011/65/EC. In compliance with the above regulations the products are CE marked.

This Operating Instruction describes the main features of the CP405 and CP408 Control Panels. The Operating Instructions refer to the following models:

Picture	Type	Description
	CP405 (Order No. 1SAP500405R0001)	CP405 Control Panel, TFT graphical display, touch screen, 7", 800 x 480 pixels
	CP408 (Order No. 1SAP500408R0001)	CP408 Control Panel, TFT graphical display, touch screen, 10.1", 1024 x 600 pixels

Before You Start

Safety Notices



DANGER!

Indicates an imminent risk. It will lead to death or serious injury if not avoided.



WARNING!

Indicates a possible risk. It may lead to death or serious injury if not avoided.



CAUTION!

Indicates a possible risk. It may lead to light or slight injury or material damage if not avoided.

Markups

- Enumeration.
- ✓ Precondition for an operation instruction or a description.
- Operation instruction with one step.
- 1. Operation instruction with several steps.
- Result of an operation.



NOTE

Helpful information with background information or an emphasized notice.



TIP

Application tips or other useful information and suggestions.

Product Overview

The Control Panels combine state-of-the-art features and top performance with an outstanding design. They are the ideal choice for all demanding HMI applications including discrete automation and most industrial applications.

These Control Panels have been designed to run the CP400PB Panel Builder 400 software.

- CP400PB Panel Builder 400 Runtime included.
- Full object dynamics: Control visibility and transparency, move and resize any object on screen. Change properties of basic and complex objects.
- Multilanguage applications. Easily create and manage your applications in multiple languages to meet global requirements. Far East languages are supported.
- Data display in numerical, text, bar graph, analog gauges and graphic image formats.
- Rich set of state-of-the-art HMI features: Data acquisition, alarm handling, scheduler, recipes, users and passwords.
- Includes support for a set of communication drivers e.g. AC500/AC500eCo and Motion drives.
- Offline and online simulation with CP400PB Panel Builder 400.
- Powerful scripting language for automating HMI applications. Script debugging improves efficiency in application development.

Standards and Approvals

The Control Panels have been designed for installation and use in an industrial environment in compliance with the 2004/108/EC EMC directive and with the following harmonized standards:

- EN 61000-6-4
- EN 61000-6-2

In compliance with the above regulations the products are CE marked.

The installation of these devices into residential, commercial and light-industrial environments is allowed only in the case that special measures are taken in order to get conformity to EN 61000-6-3.

The products are in compliance with the Restrictions on Certain Hazardous Substances (RoHS) directive 2011/65/EC. In compliance with the above regulations the products are CE marked.

Product Identification

The Control Panel products are identified by a product label. The label reports several information, including the model name, the part number, the power supply and three barcodes. First code is the version code, second one is the EAN code, third one it the serial number (S.N.).

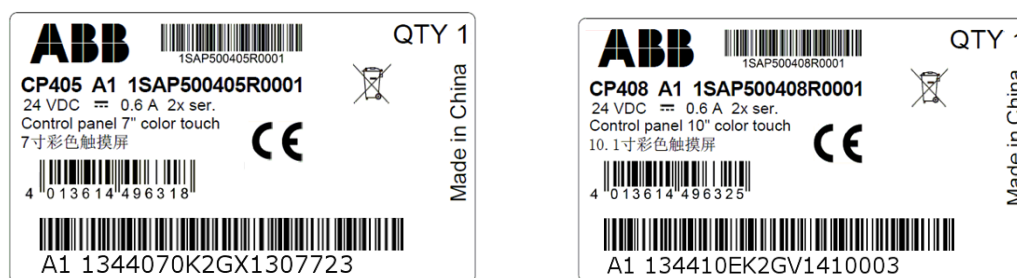

Example of product label

Information on type plate (example)	Description
CP408	Product type
1SAP500408R0001	Product part number
1254100K2GV1401009	Serial number
A0	Version number of the product

Technical Specifications

Parameter	Value
Touch screen technology	4 wire analog resistive
Backup battery	3 V 220 mAh lithium manganese dioxide (Li/MnO ₂) battery type
Fuse	Resettable
Serial port	RS-232, RS-485, RS-422 (Sub-D 9 female connector)
User memory	Flash 8 MB+128 MB for CP405, CP408
Recipe memory	Flash or 128 kB battery back-up RAM
Hardware clock	Clock/calendar with back-up battery
Accuracy RTC (at 25 °C operating)	+10 s to -5 s per day, which can be calibrated by RTC adjustment in Panel Setup.

Environmental Conditions

Parameter	Value	According to
Operating temperature (ambient air temperature)	0 ... +50 °C (32 ... 122 °F)	EN 60068-2-14
Storage temperature	-20 ... +60 °C (-4 ... 140 °F)	EN 60068-2-14
Operating humidity	10 ... 90% rel. H @ 40 °C, non-condensing	EN 60068-2-78
Storage humidity	95% rel. H @ 60 °C, non-condensing	EN 60068-2-78
Vibration	Operating, 1 G _{rms} , 5 ... 500 Hz X, Y, Z axis, 1hr each axis	EN 60068-2-64
Vibration	5 - 150 Hz 5 Hz - 11,9 Hz, ± 3,5 mm 11,9 Hz - 150 Hz, 1 g 1 Oct./min 10 sweep cycles / axis, in 3 axis	EN 60068-2-6
Shock	Half sine wave, 10G, 11ms 3 times in each direction of X-, Y-, Z-axis	EN 60068-2-27
Protection class	Front panel: IP66	EN 60529

*) The front face of the Control Panel unit, installed in a solid panel, has been tested using conditions equivalent to the standards shown in "Environmental Conditions". Even though the CP405 and CP408 unit's level of resistance is equivalent to these standards, oils that should have no effect on the Control Panel can possibly harm the unit. This can occur in areas where either vaporized oils are present, or where low viscosity cutting oils are allowed to adhere to the unit for long periods of time. If the control panel's front face protection sheet peels off, these conditions can lead to the ingress of oil into the control panel and separate protection measures are suggested. If the installation gasket is used for a long period of time, or if the unit and its gasket are removed from the panel, the original level of the protection cannot be guaranteed.

Electromagnetic Compatibility (EMC)

Immunity:

Parameter	Value	According to
Radiated disturbance test	Class A	EN 55022
Electrostatic discharge immunity test	8 kV (air electrostatic discharge) 4 kV (contact electrostatic discharge) Performance criterion B	EN 61000-4-2
Radiated, radio-frequency, electromagnetic field immunity test	80 MHz ... 1 GHz, 10 V/m 1.4 GHz ... 2 GHz, 3 V/m 2 GHz ... 2.7 GHz, 1 V/m Performance criterion A	EN 61000-4-3
Burst immunity test	± 2 kV DC power port ± 1 kV signal line Performance criterion B	EN 61000-4-4
Surge immunity test	± 0.5 kV DC power port (line to earth) ± 0.5 kV DC power port (line to line) ± 1 kV signal line (line to earth) Performance criterion B	EN 61000-4-5
Immunity to conducted disturbances induced by radio-frequency field	0.15 ... 80 MHz, 10 V Performance criterion A	EN 61000-4-6
Power frequency magnetic field immunity test	50 Hz/60 Hz, 30 A/m	EN 61000-4-8

Emission:

Parameter	Value	According to
Conducted (power)	0.15 MHz ... 0.5 MHz, 79 dBuV 0.5 MHz ... 30 MHz, 73 dBuV	EN 61000-6-4
Conducted (Telecom port)	0.15 MHz ... 0.5 MHz, 97 ... 87 dBuV 5 MHz ... 30 MHz, 87 dBuV	
Radiated	30 MHz ... 230 MHz, 40 dBuV/m 230 MHz ... 1 GHz, 47 dBuV/m	

Durability Information

Parameter	Value
Backlight life (LED type)	20,000 hr. Time of continuous operation until the brightness of the backlight reaches 50% of the rated value when the surrounding temperature reaches 25 °C. ¹
Battery lifetime	Battery capacity remains 95% after 5 years when not yet used at general environment 20 °C.
Front foil (without directly expose to sunlight or UV ray)	10 years if the surrounding temperature is 25 °C
Touch screen (resistive film, analog)	1,000,000 or more of activations

¹ Switching off the backlight in case of no use will increase the backlight's lifetime. Extended use in environments where the surrounding air temperature is 40 °C or higher may degrade backlight quality/reliability/durability.

Technical Data

Model	CP405	CP408
Display/backlight	WVGA TFT LCD	WSVGA TFT LCD
Colors	65,536	65,536
Resolution	800 x 480	1024 x 600
Diagonal (inches)	7"	10.1"
Backlight type	LED	LED
Backlight brightness	250 cd/m ²	250 cd/m ²
Viewing angle	Wide angle viewing under industrial conditions indoor: vertical: 140° horizontal: 130°	Wide angle viewing under industrial conditions indoor: vertical: 140° horizontal: 130°
Dimming	Adjustable by touch panel	Adjustable by touch panel
Touch screen	4 wire analog resistive	4 wire analog resistive
User memory flash	8 MB NOR + 128 MB NAND flash	8 MB NOR + 128 MB NAND flash
Recipe memory	Yes, flash or 128 kB battery back-up RAM	Yes, flash or 128 kB battery back-up RAM
Serial port	RS-232, RS-485, RS422 (DB9 female)	RS-232, RS-485, RS422 (DB9 female)
USB port	1 x USB (type A): Communication to printers and other typical accessories 1 x USB (type B): Port for programming	
Battery (built in)	Non-chargeable	Non-chargeable
Real-time clock	Yes	Yes
Voltage	24 VDC ± 10%	24 VDC ± 10%
Power consumption	10 W max.	10 W max.
Weight	0.55 kg (1.25 lbs) / net 0.75 kg (1.70 lbs) / gross	1.05 kg (2.35 lbs) / net 1.55 kg (3.45 lbs) / gross

Dimensions

CP405:

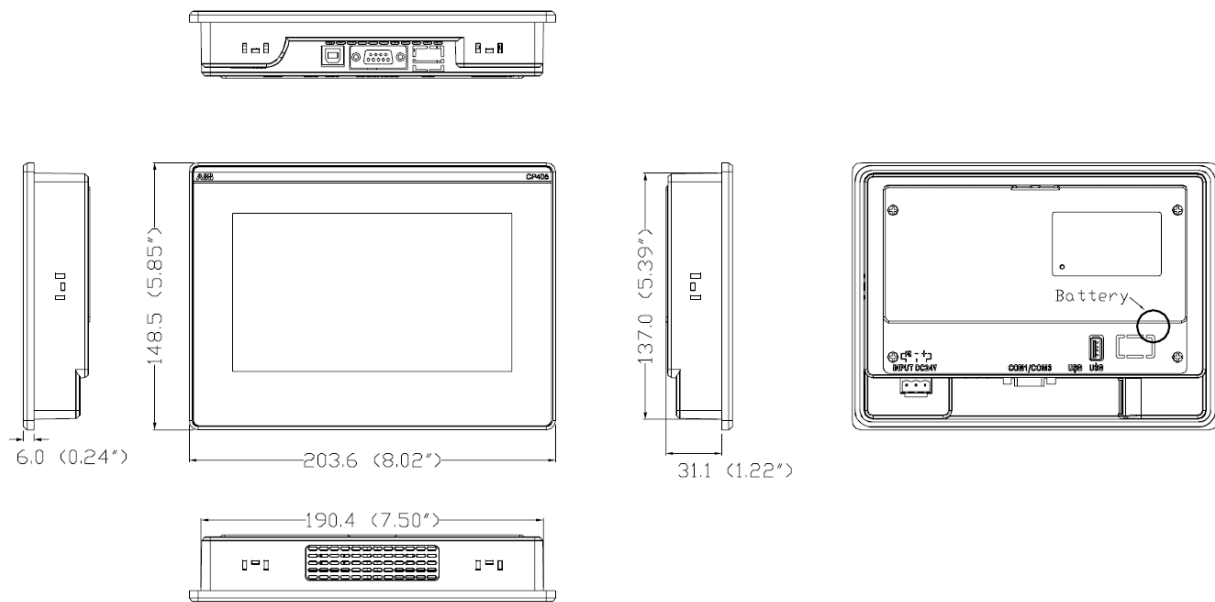

Panel Cut-out dimensions: 191.5 x 138 mm (7.54" x 5.43")

CP408:

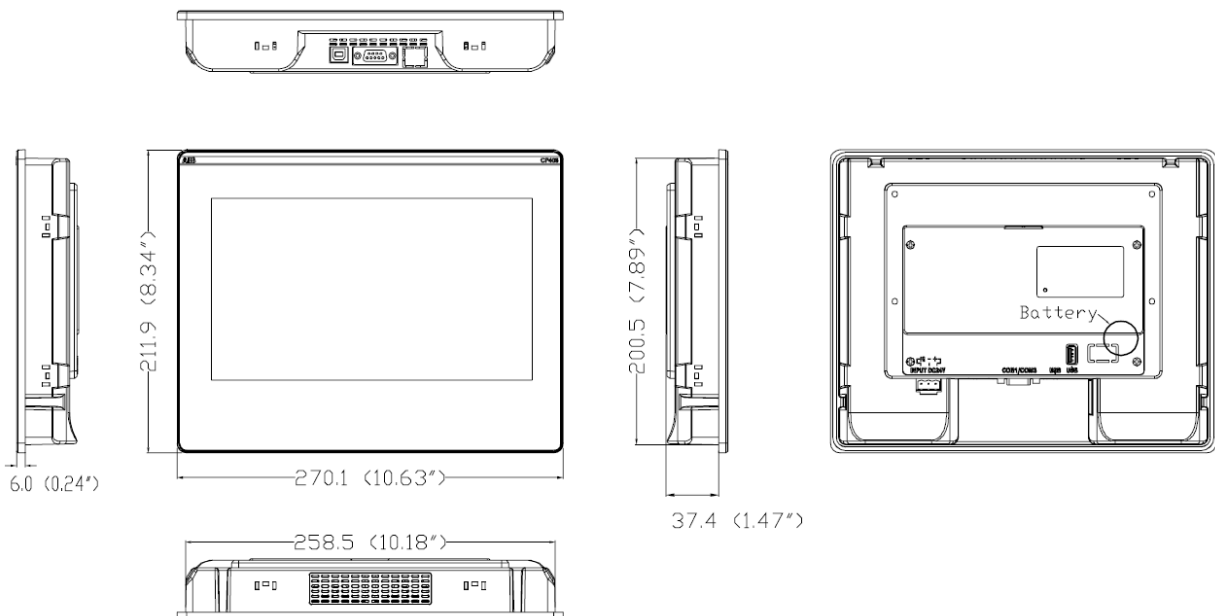

Panel Cut-out dimensions: 259.5 x 201.5 mm (10.22" x 7.93")

Outlet:

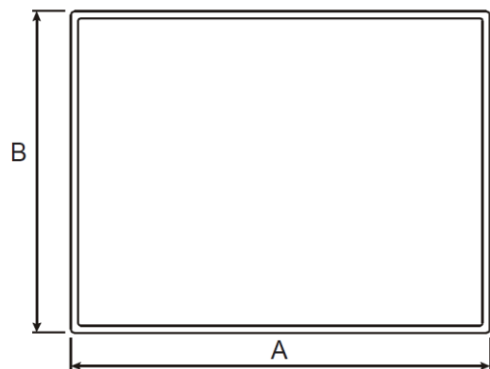

Cut-out:

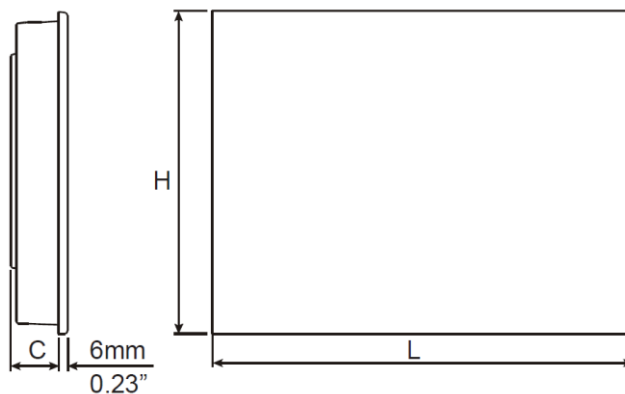

Model	A		B		C		H		L	
	mm	inches	mm	inches	mm	inches	mm	inches	mm	inches
CP405	203.6	8.02	148.5	5.85	31.1	1.22	138.0	5.43	191.5	7.54
CP408	270.1	10.63	211.9	8.34	37.4	1.47	201.5	7.93	259.5	10.22

Installation Environment

The equipment is not intended for continuous exposure to direct sunlight. This might accelerate the aging process of the front panel film.

The equipment is not intended for installation in contact with corrosive chemical compounds. Check the resistance of the front panel film to a specific compound before installation.

Do not use tools of any kind (screwdrivers etc.) to operate the touch screen of the panel.

In order to meet the front panel protection classifications, proper installation procedure must be followed:

- ✓ The borders of the cut-out must be flat.
- ✓ The cut-out for the panel must be of the dimensions indicated in this manual.
- Screw up each fixing screw until the plastic bezel corner get in contact with the panel.

The IP66 is only guaranteed if:

- Maximum deviation from the plane surface to the cut-out: Ø 0.5 mm
- Thickness of the plate the equipment is mounted: 1 mm to 10 mm
- Maximum surface roughness where the gasket is applied: Ø 120 µm

Installation Procedure

Panel fixing:

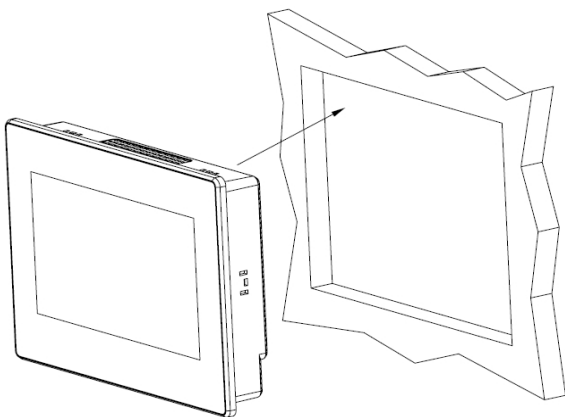

Placing the fixing brackets:

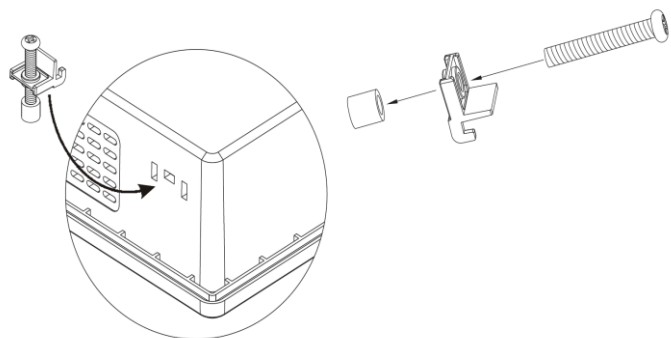

CAUTION!

Screw each fixing screw until the bezel corner gets in contact with the panel.

Connections

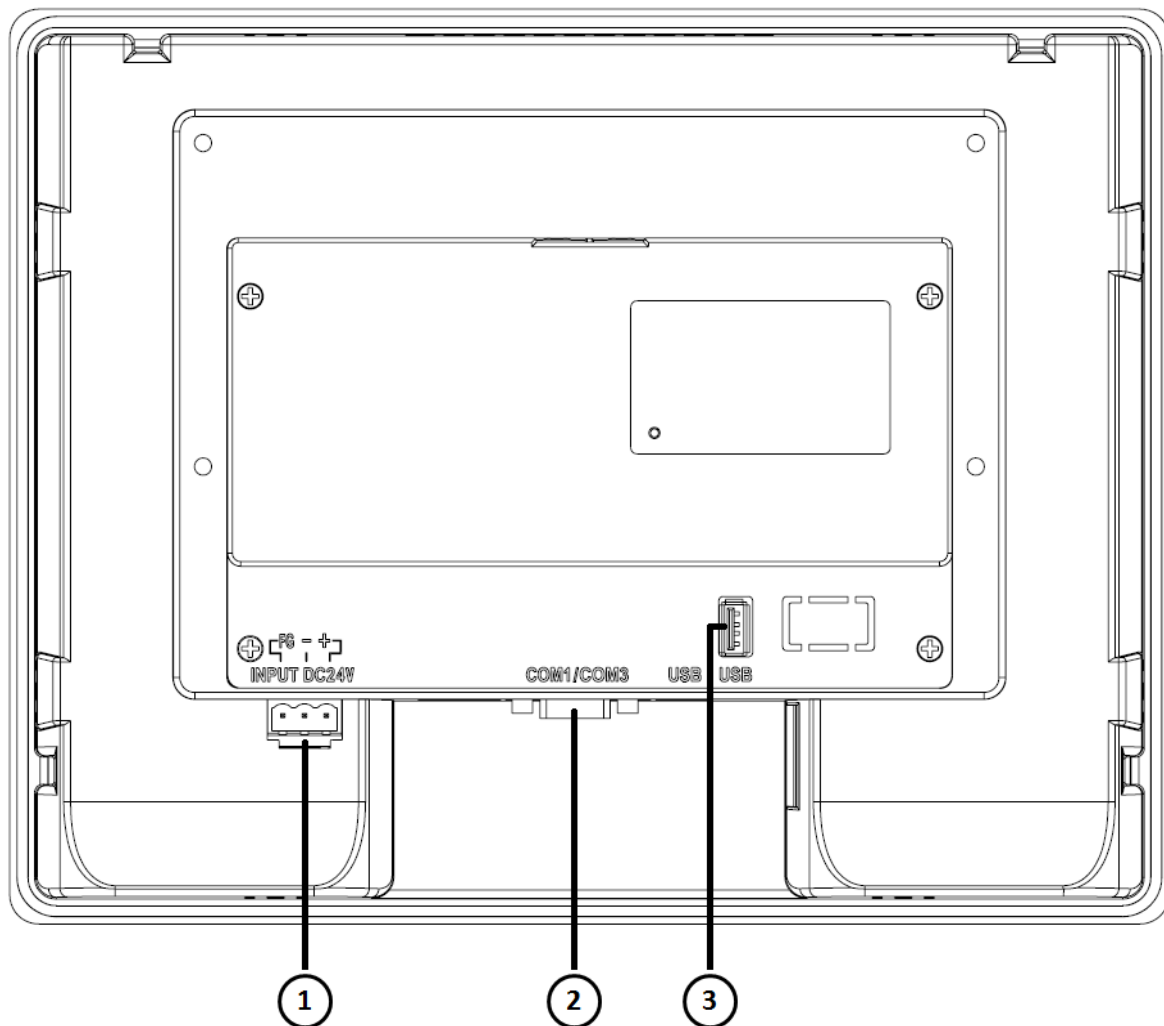

- 1** Power supply connector (Terminal) **2** Serial port COM1/ COM3 (9-Pin female) **3** USB port (type A)

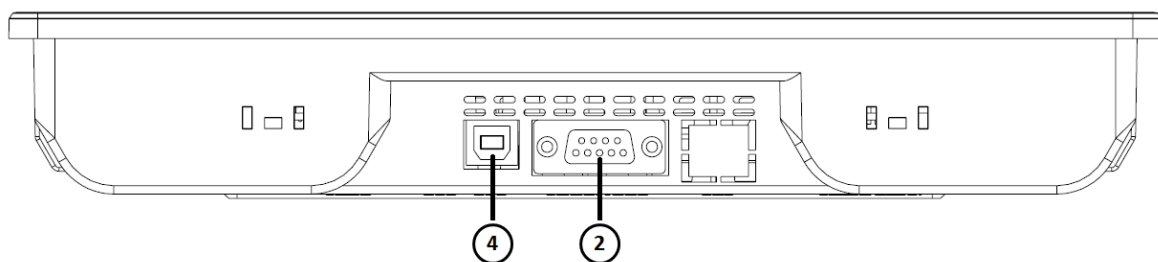

- 4** USB port (type B)

Serial Port

The serial port COM1 / COM3 is used to communicate with the PLC or with another type of controller.

Different electrical standards are available for the signals in the PLC port connector: RS-232, RS-485 and RS422.

The used cable selects the appropriate signals.



NOTE

It is always necessary to use the correct cable type to connect to the PLC.
If the proper cable is not used, communication with the PLC will not be possible.

The serial port is software programmable. Make sure you select the appropriate interface in the programming software.

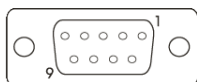

The serial connector is a DP-9 pin female



NOTE

It is highly recommended to use communication cable for AC500(-eCo) TK407 (Order No. 1SAP500467R0001).

COM1 / COM3 for CP405 / CP408 HMI					
Pin	Description	Pin	Description	Pin	Description
1	RS422_TxD + / RS485 +	4	RS422_RxD +	7	RS232_TxD (COM3)
2	RS232_RxD	5	GND	8	RS232_RxD (COM3)
3	RS232_TxD	6	RS422_TxD - / RS485 -	9	RS422_RxD -

The communication cable must be chosen for the type of device being connected.

Communication Cables

The communication cable must be chosen for the type of device being connected.

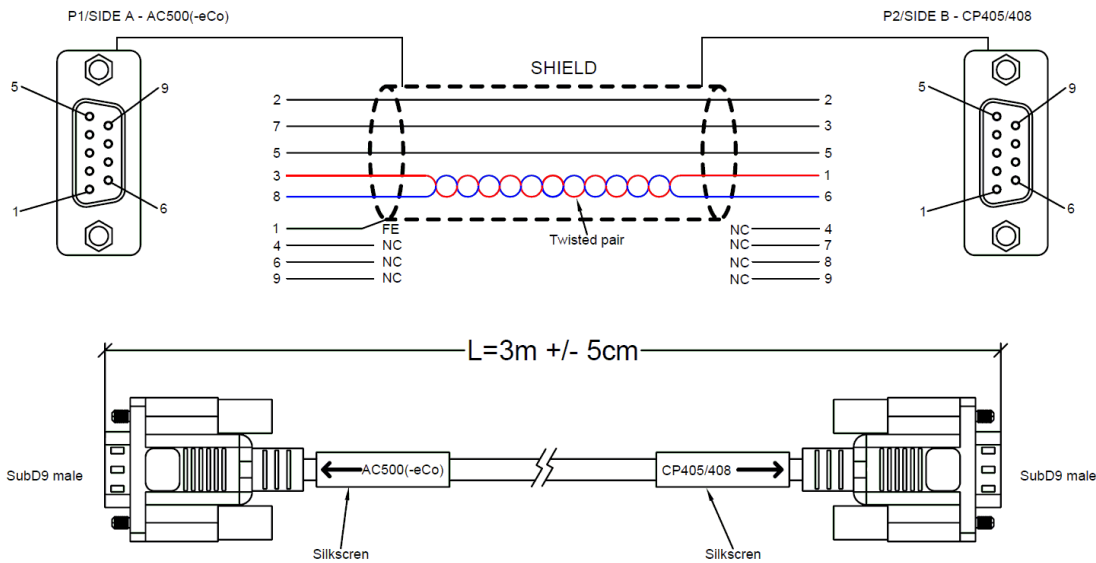

Connection to an AC500(-eCo) with the TK407 CP400-AC500(-eCo) RS485/RS232 communication cable

RS485 wiring

Pin	AC500-eCo COM1	AC500 COM2
1	FE	FE
2	SGND	RS232_TxD
3	RS485_RxD/TxD-P	RS485_RxD/TxD-P
4	Reserved	RS232_RTS
5	SGND	SGND
6	+ 3.3 V	+ 5 V
7	Reserved	RS232_RxD
8	RS485_RxD/TxD-N	RS485_RxD/TxD-N
9	Reserved	RS232_CTS

Pin	CP405 & CP408 COM1 / COM3
1	RS422_TxD-P/RS485_RxD/TxD-P
2	RS232_RxD
3	RS232_TxD
4	RS422_RxD-P
5	GND
6	RS422_TxD-N/RS485_RxD/TxD-N
7	RS232_TxD (COM3)
8	RS232_RxD (COM3)
9	RS422_RxD-N

RS232 wiring

Pin	AC500 COM2
1	FE
2	RS232_TxD
3	RS485_RxD/TxD-P
4	RS232_RTS
5	SGND
6	+ 5 V
7	RS232_RxD
8	RS485_RxD/TxD-N
9	RS232_CTS

Pin	CP405 & CP408 COM1 / COM3
1	RS422_TxD-P/RS485_RxD/TxD-P
2	RS232_RxD
3	RS232_TxD
4	RS422_RxD-P
5	GND
6	RS422_TxD-N/RS485_RxD/TxD-N
7	RS232_TxD (COM3)
8	RS232_RxD (COM3)
9	RS422_RxD-N

Power Supply, Grounding and Shielding



NOTE

Powered by a low voltage / limited energy power source.

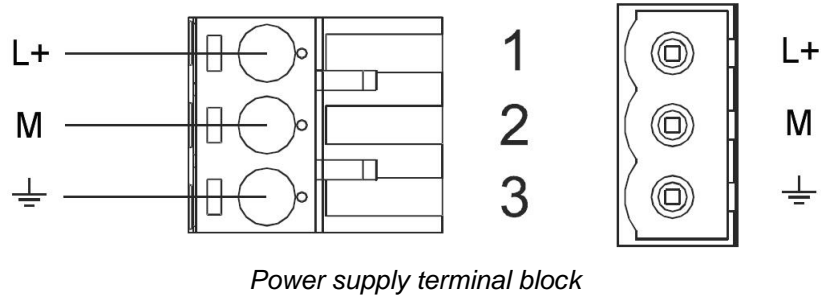

NOTE

Ensure that the power supply has enough power capacity for the operation of the equipment.



NOTE

Do not open the rear cover of the panel when power is applied.

The unit must always be grounded to earth. Grounding helps to limit the effects of noise due to electromagnetic interference on the control system.

1. Do the earth connection by using screw terminal located near the power supply terminal block. A print identify the ground connection.
2. Connect to ground the terminal 3 on the power supply terminal block.
3. The power supply circuit may be floating or grounded. In the latter case, connect to ground the power source common.

Battery

The Control Panels are equipped with a non-chargeable lithium manganese dioxide (Li/MnO₂) battery, not user-replaceable.

The battery maintains the hardware real-time clock (date and time).

CP405 / CP408:

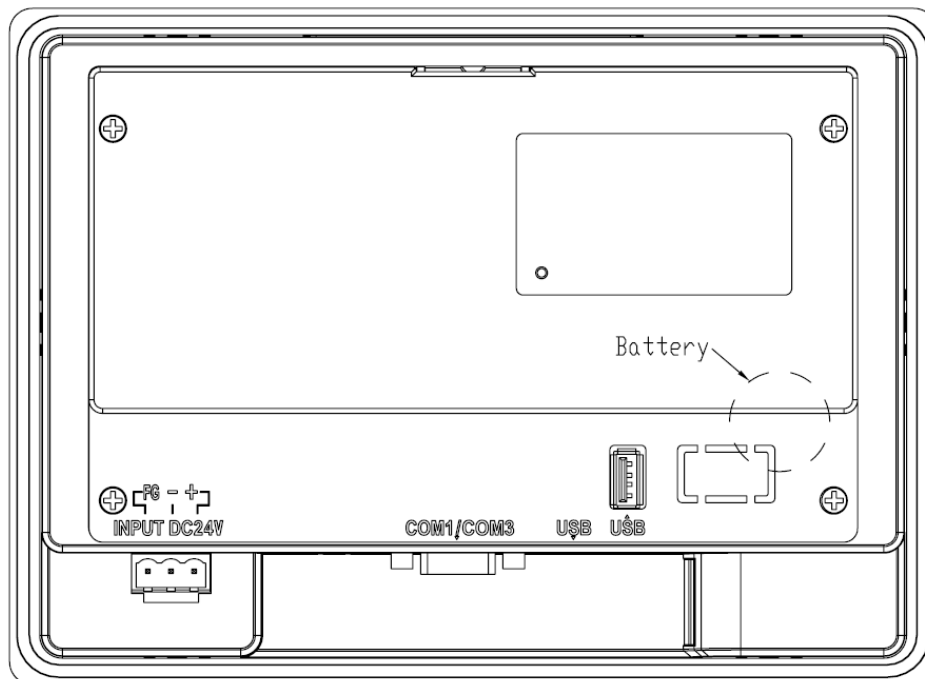

NOTE

The battery must not be disposed as unsorted domestic waste.

→ Dispose the battery according to the local regulations.



NOTE

Capacity of battery can hold for 2 years or more, without connected power supply to HMI, at 20 °C. The data in the memory may be lost under low battery condition. It is recommended to have a backup, based on flash memory. In case of empty battery, data can be restored to HMI.

alarm	Recommend to store in USB memory stick.
recipe	Recommend to store in USB memory stick.
operation log	Recommend to store in USB memory stick, however it cannot be restored to HMI.
data log	Recommend to store in USB memory stick.
\$N	Recommend to store in USB memory stick, and restore to HMI by macro via CSV file.
RTC	Recommend to calibrate with external devices, e.g. PLC.

Cleaning Faceplates

The equipment must be cleaned only with a soft cloth and neutral soap product.
Do not use solvents.

Getting Started

The Control Panels (CP405 / CP408) must be programmed with the programming package CP400PB Panel Builder 400.

The Control Panels are programmed via COM1 / COM3 and USB (type B) interface.

→ To program a Control Panel connect the Control Panel to a PC running CP400PB Panel Builder 400 software package.

The software package CP400PB Panel Builder 400 is a Windows 7/Vista 32- or 64-bit-based application and must be properly installed. Windows 7/Vista 32-/64-bit environment is not included in the software package CP400PB Panel Builder 400 and must already be installed on PC.

CP400PB Panel Builder 400 uses the USB (type B) interface via to communicate with the target device.

The version of the Panel Builder used must be compatible with the CP400PB Panel Builder 400 Runtime version installed on the Control Panel to be programmed. An update of the panel's runtime will be done automatically by downloading a project created with newer CP400PB version.

Panel Setup

The Control Panels provide a system settings tool to allow basic and preliminary settings to the unit.



NOTE

Some of the buttons on the setup screen appear only when they are needed.

After powering up, the target panel will not display the setup screen if “Run AP after Power On” in the General Settings is set to True. The target panel will run the application directly.

The following table describes the function of each button on the setup screen of the target panel.

Property	Press the button to ...
English	display the texts of the screen in the corresponding language.
General	set the contrast and brightness of the display.
Touch Panel	calibrate the touch panel.
Set Time/Date	set the date and time on the real-time clock chip.

<p>H/W Information</p>	<p>display the hardware information of the target panel. The following picture describes the hardware information screen.</p>  <p>The screenshot shows a window titled 'H/W Information' with the following fields:</p> <ul style="list-style-type: none"> Serial Number: 07EK2GV1400009 Model Name: CP405 DRAM Size (MB): 32 Battery Backed RAM Size (KB): 128 Flash ROM Size (MB): 8 NAND Flash ROM Size (MB): 128 MAC Address: (empty) Touch Panel Type: 0 (hex: 0058 00D0 0FA0 0F10 / 0060 0187 0F8A 0EFA) Touch Panel Decoder Type: 1 COM Port: COM1/COM3 Ethernet Port: None Micro SD Card Socket: None Real Time Clock: Available Licensed Drivers Supported: True <p>A 'Close' button is located at the bottom right of the window.</p>
<p>Link 1 – Link 4</p>	<p>set the parameters for communication between the target panel and PLC/Controllers.</p>
<p>Copy AP to HMI</p>	<p>copy the application to another HMI.</p>
<p>Copy AP to File</p>	<p>save the system programs and the application runtime data to a PRP file. The file can be used by the software and compatible target panels.</p>
<p>Copy File</p>	<p>copy the file.</p>
<p>Delete File</p>	<p>delete the file.</p>
<p>Format Disk C</p>	<p>format the built-in flash disk (C:). This operation requires a user level of 8 or higher.</p>
<p>Boot from File</p>	<p>load-and-run the system programs and the application runtime data from a PRP file. The original system programs and runtime data are intact. The loaded system programs and the runtime data will be lost after power off.</p>
<p>Update from File</p>	<p>update the system programs and the application runtime data from a PRP file. The original system programs and the application runtime data are replaced by the new ones.</p>
<p>Clear Recorded Data</p>	<p>clear the data stored in the battery backed RAM, which include the operation history, alarm history, alarm counts, and the data collected by data loggers. This operation requires a user level of 7 or higher.</p>
<p>Run</p>	<p>start running the application. If login is required, the operator must enter a valid password of any user level before the target panel displays the first screen. The user level of the password you enter becomes the current user level. Any operation that requires a user level higher than the current user level will not work while the application is still running.</p>

ABB Automation Products GmbH

Wallstadter Str. 59

68526 Ladenburg, Germany

Phone: +49 62 21 701 1444

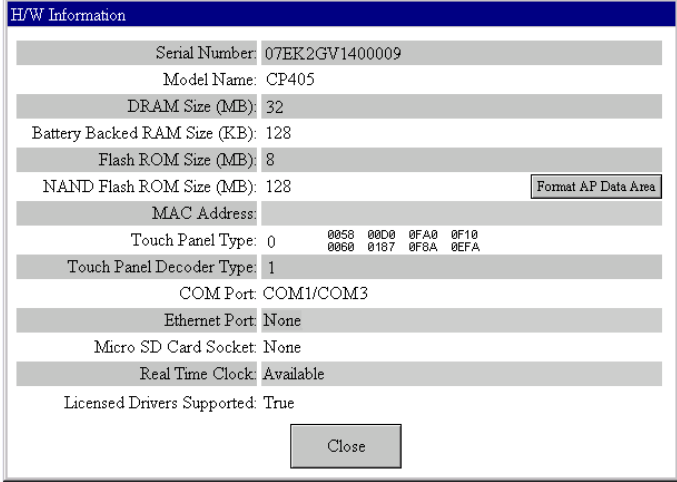
Fax: +49 62 21 701 1382

E-Mail: plc.sales@de.abb.com

www.abb.com/plc

Note:

We reserve the right to make technical changes or modify the contents of this document without prior notice. With regard to purchase orders, the agreed particulars shall prevail. ABB AG does not accept any responsibility whatsoever for potential errors or possible lack of information in this document.

We reserve all rights in this document and in the subject matter and illustrations contained therein. Any reproduction, disclosure to third parties or utilization of its contents – in whole or in parts – is forbidden without prior written consent of ABB AG.

© Copyright 2011-2014 ABB.

All rights reserved.

Subject to alterations.

3ADF059038M0201