

# ICS4\_6x-Series

## Explosion proof weighing solutions

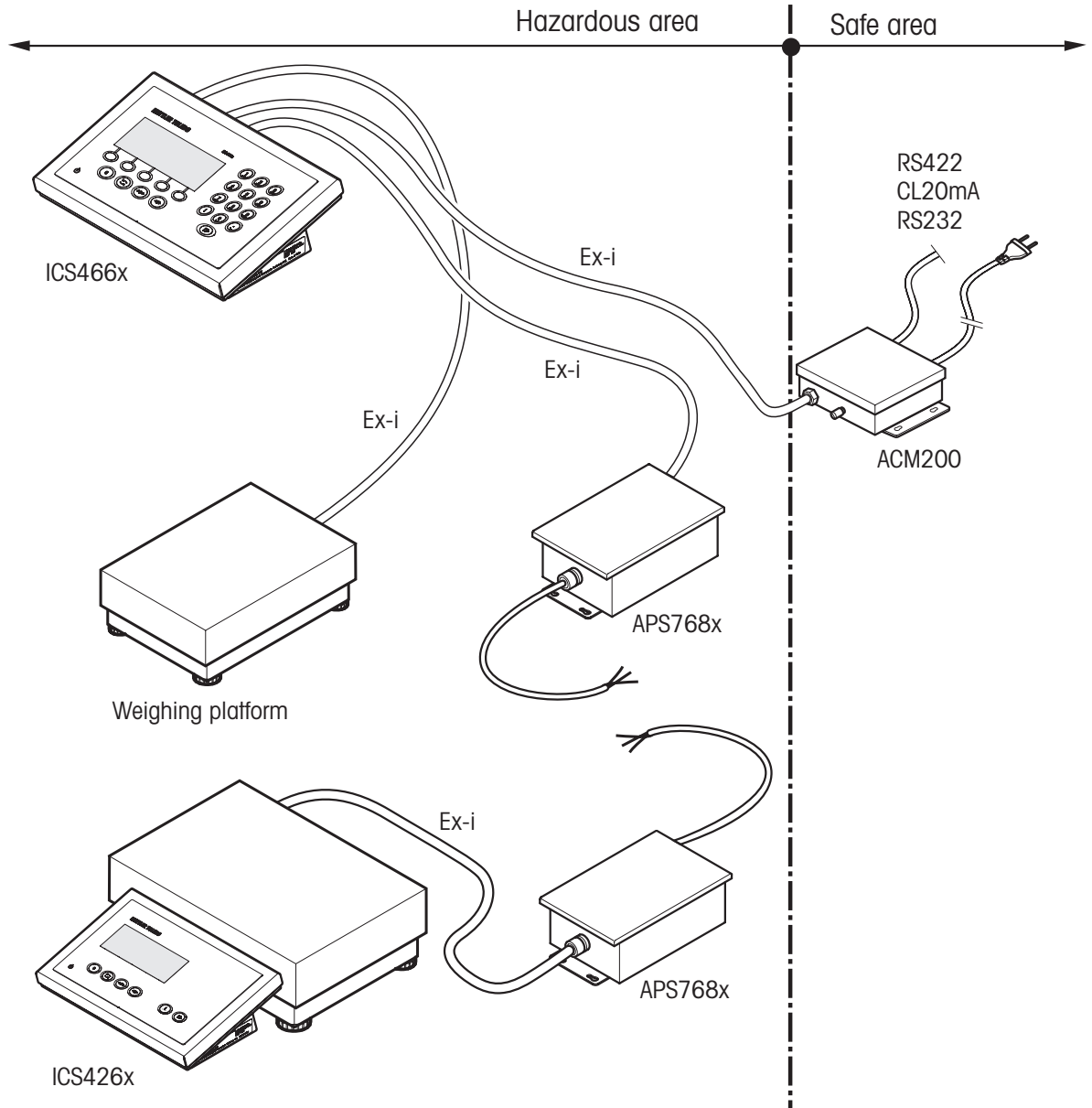

**METTLER TOLEDO**

## English (Original instructions)

# METTLER TOLEDO Service

Congratulations on choosing the quality and precision of METTLER TOLEDO. Proper use of your new equipment according to this manual and regular calibration and maintenance by our factory-trained service team ensures dependable and accurate operation, protecting your investment. Contact us about a service agreement tailored to your needs and budget. Further information is available at [www.mt.com/service](http://www.mt.com/service).

There are several important ways to ensure you maximize the performance of your investment:

1. **Register your product:** We invite you to register your product at [www.mt.com/productregistration](http://www.mt.com/productregistration) so we can contact you about enhancements, updates and important notifications concerning your product.
2. **Contact METTLER TOLEDO for service:** The value of a measurement is proportional to its accuracy – an out of specification scale can diminish quality, reduce profits and increase liability. Timely service from METTLER TOLEDO will ensure accuracy and optimize uptime and equipment life.
  - **Installation, Configuration, Integration and Training:**  
Our service representatives are factory-trained weighing equipment experts. We make certain that your weighing equipment is ready for production in a cost effective and timely fashion and that personnel are trained for success.
  - **Initial Calibration Documentation:**  
The installation environment and application requirements are unique for every industrial scale so performance must be tested and certified. Our calibration services and certificates document accuracy to ensure production quality and provide a quality system record of performance.
  - **Periodic Calibration Maintenance:**  
A Calibration Service Agreement provides on-going confidence in your weighing process and documentation of compliance with requirements. We offer a variety of service plans that are scheduled to meet your needs and designed to fit your budget.

# Contents

<b>1</b>	<b>Safety instructions.....</b>	<b>4</b>
<b>2</b>	<b>System overview .....</b>	<b>6</b>
2.1	Typical configurations .....	6
2.2	Description of components.....	9
<b>3</b>	<b>Installation .....</b>	<b>11</b>
3.1	Setting up system modules .....	11
3.2	Connecting devices.....	12
3.3	Installing the equipotential bonding.....	13
3.4	Connecting power supply.....	13
3.5	Cleaning after installation .....	13
<b>4</b>	<b>Optional work.....</b>	<b>14</b>
4.1	Customizing connection cables: Weighing platform / APS768x.....	14
4.2	Customizing connection cables: interface converter ACM200 .....	15
<b>5</b>	<b>Technical data .....</b>	<b>16</b>
5.1	Dimensional drawing ICS4_6x .....	16
<b>6</b>	<b>Disposal.....</b>	<b>16</b>
<b>7</b>	<b>Control Drawing .....</b>	<b>18</b>
7.1	ICS466x with analog and digital scale .....	18
7.2	ICS466x with analog and digital scale and a second ICS466x.....	22
7.3	ICS466x with barcode reader .....	26
7.4	ICS426x .....	28

# 1 Safety instructions



The ICS4\_6x weighing terminals are approved for operation in Category 2 / DIV1 hazardous areas.

If the ICS4\_6x weighing terminals are used in hazardous areas, special care must be taken. The code of practice is oriented to the "Safe Distribution" concept drawn up by METTLER TOLEDO.

- Competence**
- ▲ The weighing system may only be installed, maintained and repaired by authorized METTLER TOLEDO service personnel.
  - ▲ The mains supply may only be installed by a specialist authorized by the owner-operator.

- Ex approval**
- ▲ No modifications may be made to the terminal and no repair work may be performed on the modules. Any weighing platform or system modules that are used must comply with the specifications contained in this Installation manual. Non-compliant equipment jeopardizes the intrinsic safety of the system, cancels the "Ex" approval and renders any warranty or product liability claims null and void.
  - ▲ The safety of the weighing system is only guaranteed when the weighing system is operated, installed and maintained in accordance with the respective instructions.
  - ▲ Also comply with the following:
    - the instructions for the system modules,
    - the regulations and standards in the respective country,
    - the statutory requirement for electrical equipment installed in hazardous areas in the respective country,
    - all instructions related to safety issued by the owner.
  - ▲ The explosion-protected weighing system must be checked to ensure compliance with the requirements for safety before being put into service for the first time, following any service work and every 3 years, at least.

**Operation**



- ▲ Prevent the build-up of static electricity.
  - Always wear suitable working clothes when operating or performing service work in a hazardous area.
  - Only use the weighing terminal when electrostatic processes leading to propagating brush discharges are impossible.
- ▲ Prevent the build-up of dust layers.
- ▲ Do not use protective coverings for the devices.
- ▲ Protect the keyboard membrane against ultraviolet radiation.
- ▲ Avoid damage to the system components.

- Installation**
- ▲ Only install or perform maintenance work on the weighing system in the hazardous areas if the following conditions are fulfilled:
    - the intrinsically safe characteristic values and zone approval of the individual components are in accordance with one another,
    - the owner has issued a permit ("spark permit" or "fire permit"),
    - the area has been rendered safe and the owner's safety co-ordinator has confirmed that there is no danger,
    - the necessary tools and any required protective clothing are provided (danger of the build-up of static electricity).
  - ▲ The certification papers (certificates, manufacturer's declarations) must be present. Follow zone classification and special conditions.
  - ▲ Lay cabling securely so that it does not move and effectively protect it against damage.
  - ▲ Only route cables into the housing of the system modules via the approved earthing cable glands and ensure proper seating of the seals.

## 2 System overview

### 2.1 Typical configurations

The ICS4\_6x-series comprises the following weighing terminals:

- ICS466x
- ICS426x

A weighing system with an ICS4\_6x weighing terminal can be operated either with one of the following power supply units:

<b>APS768x-120 V</b>	Power supply unit in a hazardous area, US version, 120 VAC, 50/60 Hz
<b>APS768x-230 V</b>	Power supply unit in a hazardous area, EU version, 230 VAC, 50/60 Hz

	System overview	
	ICS426x	ICS466x
	The weighing terminal can be fixed to a digital weighing platform, e.g., PBK9-/PFK9-series approved for Category 2 / Division 1.	Either an analog or a digital weighing platform can be connected.
<b>Digital scale interface</b>	Active intrinsically safe scale interface, to connect digital weighing platforms, e.g., K...x-T4, PBK9-/PFK9-series approved for Category 2 / Division 1	
<b>Analog scale interface PDC-SG-Ex1</b>	–	Active intrinsically safe A/D converter, to connect analog weighing platforms in the hazardous area Category 2 / Division 1
<b>Active CL interface</b>	Optional active intrinsically safe data interface, to allow communication with the safe area via ACM200	
<b>Passive CL interface</b>	–	Optional passive intrinsically safe data interface, to connect a second intrinsically safe digital scale interface. The second scale has to be powered externally by a second APS768x.
<b>RS232-IS</b>	Intrinsically safe communication interface located on the backplane, to connect an intrinsically safe peripheral device, e.g., barcode reader, or via barrier to peripheral equipment. Peripheral devices must be powered externally.	
<b>ACM200</b>	External interface converter for the safe area, e.g., to connect a PC in the safe area	

### 2.1.1 ICS466x configuration with interface converter ACM200 in the safe area

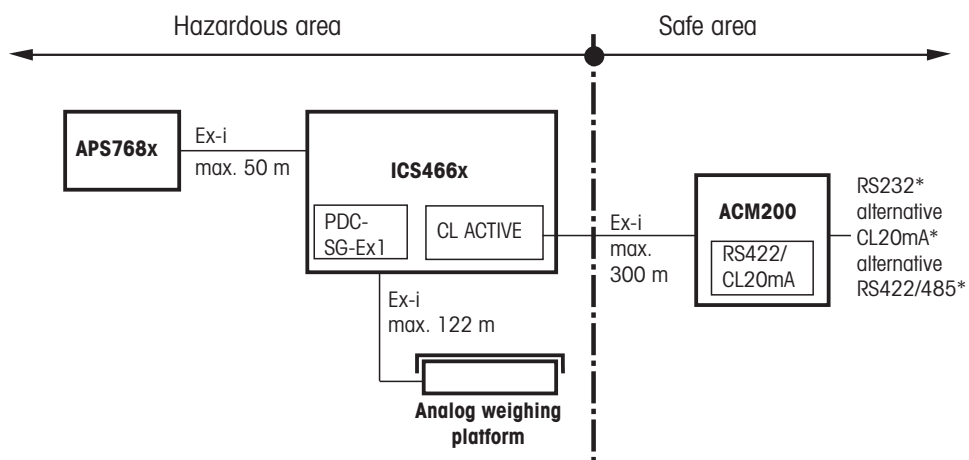

\* only one hardware interface available;  
CL20mA and RS422/485 only with module ACM200-CL/RS422

### 2.1.2 ICS466x configuration with PC in the safe area

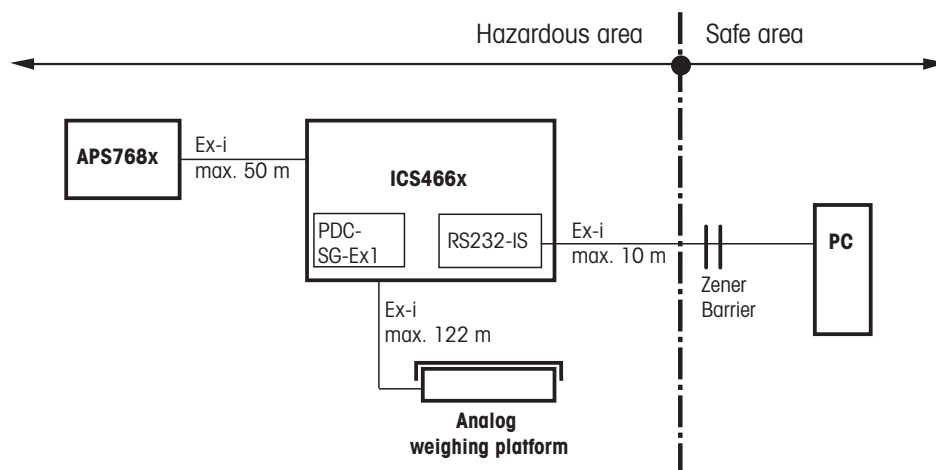

**2.1.3 ICS466x configuration with 2 digital weighing platforms in the hazardous area**

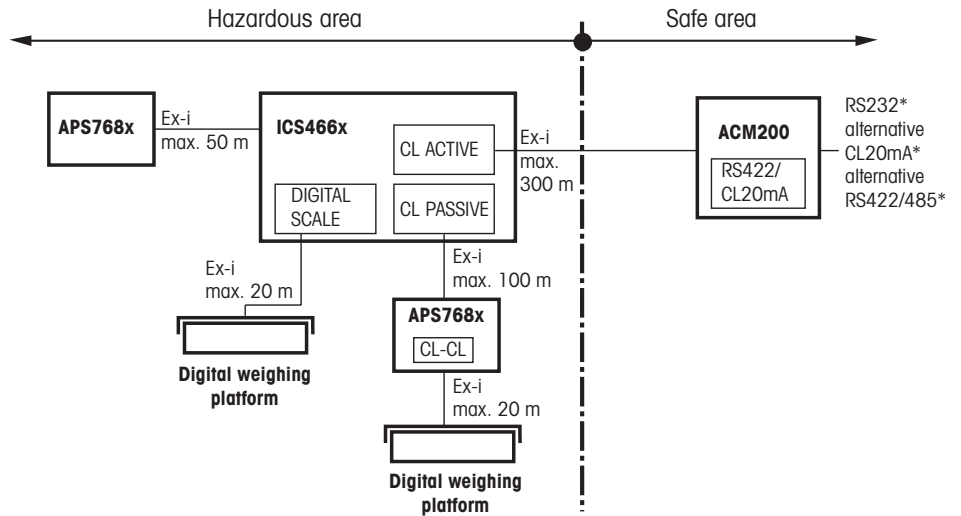

\* only one hardware interface available,  
CL20mA and RS422/485 only with module ACM200-CL/RS422

**2.1.4 ICS426x configuration with PC in the safe area**

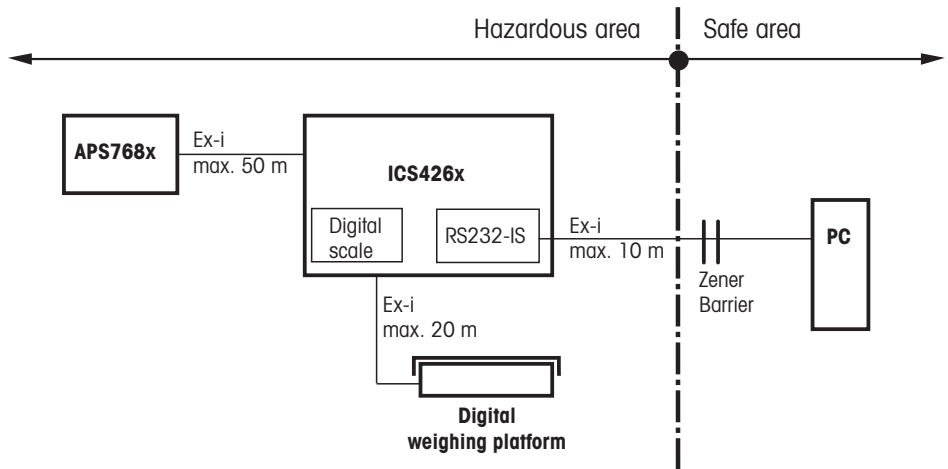



## 2.2 Description of components

### 2.2.1 Approvals

<b>ICS4_6x</b>	Ignition protection type	EN/IECEX	II 2G Ex ib IIC T4 Gb, -10 °C ... +40 °C II 2D Ex ib IIIC T60°C Db IP65 BVS 13 ATEX E042X IECEX BVS 13.0050X IS Class I, II, III; Division 1; Group A, B, C, D, E, F, G; T4; Ta = 40 °C AEx ib IIC T4; IP65; Type 4 FM16US0098
		$c^{FM}_{US}$	
<b>Power supply unit APS768x</b>	See APS768x Guide for Installers		
<b>Analog weighing platforms</b>	See Operating Instructions / Installation Information of the weighing platforms		
<b>PBK9-/PFK9-series weighing platforms</b>	See Operating Instructions / Installation Information of the PBK9-/PFK9-series weighing platforms with option Category 2 / DIV1		
<b>Interface converter ACM200</b>	Ignition protection type	EN/IECEX	II (2)G [Ex ib Gb] IIC II (2)D [Ex ib Db] IIIC BVS 07 ATEX E149 IECEX BVS 11.0080 AIS Class I, II, III; Division 1; Group A, B, C, D, E, F, G Project ID: 3033370
		$c^{FM}_{US}$	

## 2.2.2

### Connections

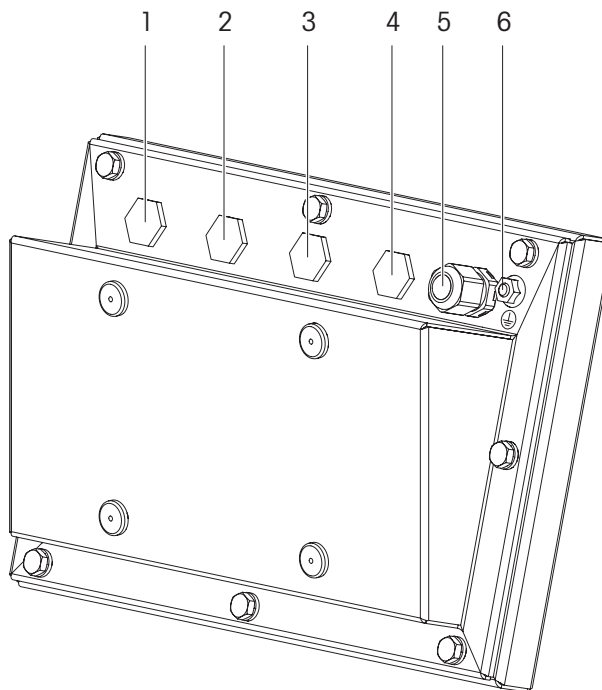

- 1** Power supply unit APS768x
- 2** Intrinsically safe RS232 interface
- 3** Communication interface
- 4** Second (digital) weighing platform (ICS466x only)
- 5** Weighing platform (analog or digital)
- 6** Equipotential bonding terminal (EB)

#### Note

- On connections (1) to (4) blind plugs are mounted at the factory.
- When connecting METTLER TOLEDO devices, M16x1.5 cable glands are provided with the devices.
- The cable gland on connection (5) is provided for connecting an analog weighing platform.

## 3 Installation



### EXPLOSION HAZARD

- Follow the special conditions listed in the certificates.
- The explosion-protected weighing system may only be installed according to this Installation manual and the Control Drawing 22026630 on Pages 18 and following.
- Keep the weighing terminal away from processes which generate high charging potential such as electrostatic coating, rapid transfer of non-conductive materials, rapid air jets and high pressure aerosols.

### 3.1 Setting up system modules

#### 3.1.1 Setting up the ICS4\_6x weighing terminal

- Select a suitable installation site.

#### Bench stand or floor stand mounting \*

- Place the ICS4\_6x weighing terminal onto the bench or floor stand and mount it with 4 screws.

#### Wall mounting \*

- The ICS4\_6x weighing terminal can be mounted to a wall using the wall bracket (accessory).

#### Front mounting \*

The ICS426x weighing terminal can be fixed in front of the weighing platform using the front mount bracket (accessory).

\* For details on mounting the weighing terminal refer to the "Columns and brackets" Mounting instructions 22013828.

#### 3.1.2 Setting up the weighing platform

- Set up the weighing platform in accordance with the corresponding Operating and Installation Instructions.

#### 3.1.3 Setting up the power supply unit

- Set up the power supply unit in accordance with the corresponding instructions.

#### 3.1.4 Setting up the ACM200

- Set up the interface converter ACM200 in the safe area according to the corresponding instructions.

## 3.2 Connecting devices

### CAUTION

- The clamping section of the earthing cable gland must correspond to the outer diameter of the weighing platform cable to be connected.
- Use the supplied flexible tubes to protect the individual wires of the weighing platform cable on the inside of the ICS4\_6x.

Connect the devices in the following order:

1. Connect the weighing platform to the weighing terminal.
2. Connect the power supply unit APS768x to the weighing terminal.
3. Connect the interface converter ACM200, if present, to the weighing terminal.
4. Install the equipotential bonding, see section 3.3 on page 13.
5. Connect power supply, see section 3.4 on page 13.

### 3.2.1 Preparatory work

Connection of the devices is generally carried out with the accompanying standard cables. Cables of other lengths can be used instead of the standard cables if they are customized in accordance with Chapter 4.1 or 4.2. This applies for the following connections:

- from the weighing platform to the weighing terminal,
- from the power supply unit APS768x to the weighing terminal,
- from the interface converter ACM200 to the weighing terminal.

### 3.2.2 General connection procedure

1. Open the device.
2. Pull the customized cable through the earthing cable gland. To do this
  - dismantle the earthing cable gland or remove the blind plug,
  - ensure the exact course of the cable and properly positioned seals,
  - tighten the earthing cable gland.
3. Connect the cable in the device according to the control drawing.
4. Close device.

### 3.2.3 Interface installation

For installing an interface board refer to the ICS4\_6x Service manual.

### 3.3 Installing the equipotential bonding

Equipotential bonding must be installed by an electrician authorized by the owner. METTLER TOLEDO Service only has a monitoring and consulting function here.

- Connect equipotential bonding (EB) of all devices (power supply unit, weighing terminal, interface converter and weighing platform) in accordance with the control drawing and the country-specific regulations and standards. In the process it must be ensured that
- all device housings are connected to the same potential via the EB terminals,
  - no circulating current flows via the cable shielding for intrinsically safe circuits,
  - the neutral point for equipotential bonding is as close to the weighing system as possible.

### 3.4 Connecting power supply



#### EXPLOSION HAZARD

The mains connection of the power supply unit must be made by a professional electrician authorized by the owner and in accordance with the respective control drawing, the accompanying installation instructions as well as the country-specific regulations.

### 3.5 Cleaning after installation



#### EXPLOSION HAZARD

- ▲ Strictly observe the instructions of the operating company.
- ▲ Avoid electrostatic charging by wearing suitable working clothes when operating in hazardous areas.

#### Notes on cleaning

- Only use a clean damp cloth and gently wipe the keypad.
- Use water or mild, non-abrasive cleaning agents.
- Do not spray cleaner directly on the weighing terminal.
- Do not use any acids, alkalis or strong solvents.
- Do not clean the weighing terminal using high-pressure or high-temperature water.
- Observe all existing regulations on cleaning intervals and permissible cleaning agents.
- Remove dust layers.
- Do not use compressed air or vacuum.

## 4 Optional work

### 4.1 Customizing connection cables: Weighing platform / APS768x

Customer-specific cables for intrinsically safe circuits must be customized as follows:

	ICS4_6x – APS768x	ICS4_6x – Weighing platform *
<b>Cable</b>	4 x 2 x 0.5 mm <sup>2</sup> + 1 x 0.5 mm <sup>2</sup>	3 x 2 x 0.75 mm <sup>2</sup>
<b>Dimension A (ICS4_6x)</b>	80 mm (3,1")	80 mm (3,1")
<b>Dimension B</b>	215 mm (8.5")	215 mm (8.5")
<b>Max. length</b>	50 m (165 ft)	analog scale: 122 m (400 ft) digital scale: 20 m (66 ft)

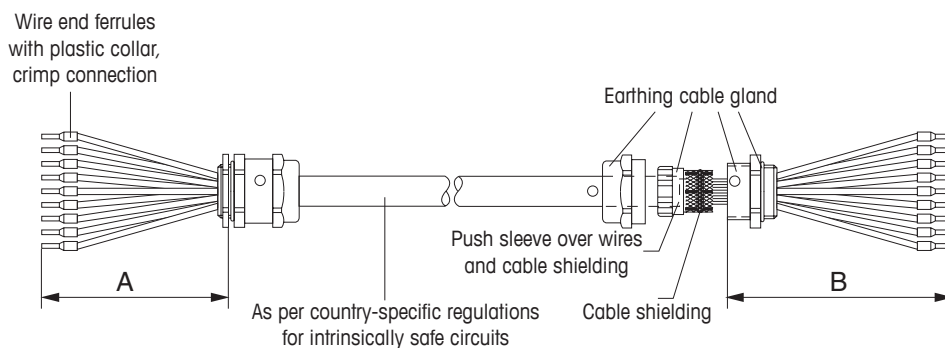

1. Cut cable to length and strip cable ends according to dimensions A/B.
2. Shorten cable shielding on both sides to 10 mm (0.4").
3. Strip wire ends.
4. Crimp wire end ferrules onto wire ends with a crimping tool.
5. Push second rear section of earthing cable gland onto cable.
6. Push sleeve over wires and cable shielding. Fold over cable shielding.
7. Push on front section of cable gland and screw onto rear section.

\* For connecting weighing platforms of the PBK9-/PFK9-series approved for Category 2 / Division 1 a cable with M12 plug is used. The cable is available in various lengths, see order form.

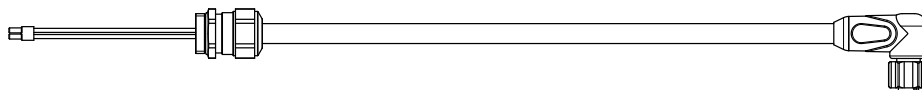

## 4.2 Customizing connection cables: interface converter ACM200

Customer-specific cables for intrinsically safe circuits must be customized as follows:

	ICS4_6x – ACM200
<b>Cable</b>	2 x 2 x 0.5 mm <sup>2</sup>
<b>Dimension A (ICS4_6x)</b>	60 mm (2.4")
<b>Dimension B</b>	70 mm (2.8")
<b>Max. length</b>	300 m (1000 ft)

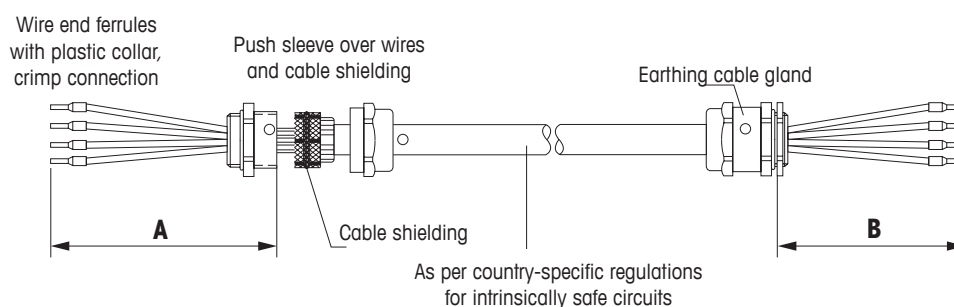

1. Cut cable to length and strip cable ends according to dimension A/B.
2. Shorten cable shielding on both sides to 10 mm (0.4").
3. Strip wire ends.
4. Crimp wire end ferrules onto wire ends with a crimping tool.
5. Push second rear section of earthing cable gland onto the cable.
6. Apply the cable shielding only to the ICS4\_6x end.  
To do so, push the sleeve over the wires and the cable shielding and fold over the cable shielding.
7. Push on front section of cable gland and screw onto rear section.

## 5 Technical data

### 5.1 Dimensional drawing ICS4\_6x

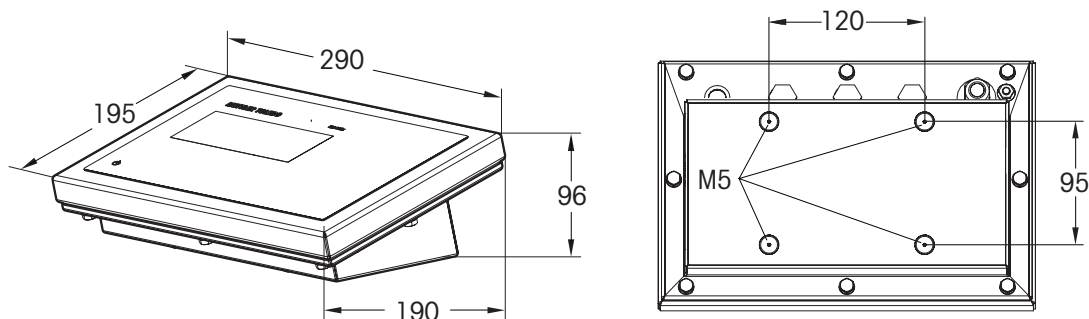

## 6 Disposal



In conformance with the European Directive 2002/96 EC on Waste Electrical and Electronic Equipment (WEEE), this device may not be disposed of with domestic waste. This also applies to countries outside the EU, according to their specific requirements.

→ Please dispose of this product in accordance with local regulations at the collecting point specified for electrical and electronic equipment.

If you have any questions, please contact the responsible authority or the distributor from which you purchased this device.

Should this device be passed on to other parties (for private or professional use), the content of this regulation must also be related.

Thank you for your contribution to environmental protection.





# 7 Control Drawing

## 7.1 ICS466x with analog and digital scale

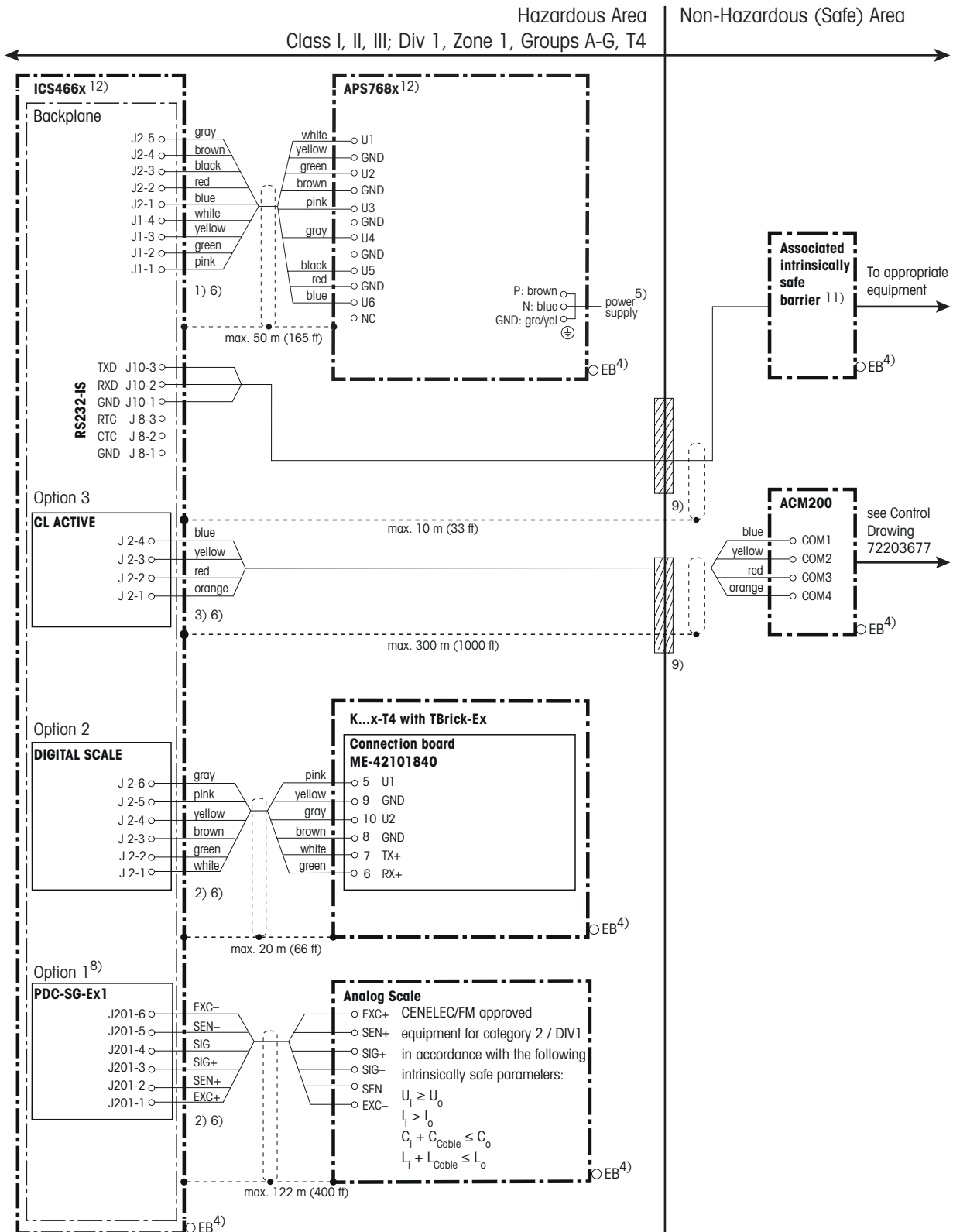

### Intrinsically safe connection values

APS768x	U <sub>0</sub> [V]	I <sub>0</sub> [mA]	P <sub>0</sub> [W]	C <sub>0</sub> [μF]	L <sub>0</sub> [mH]
U1	8.7	133	1.15	1	0.3
U2	12.6	42	0.53	0.4	1
U3	7.15	107	0.77	1	0.3
U4	10.5	74	0.78	0.6	0.3
U5	5.4	240	1.30	1	0.3
U6	12.6	92	1.16	0.5	0.3
PDC-SG-Ex1	U <sub>0</sub> [V]	I <sub>0</sub> [mA]	P <sub>0</sub> [W]	C <sub>0</sub> [μF]	L <sub>0</sub> [mH]
J201	5.36	107	0.574	0.2	0.3
DIGITAL SCALE	U <sub>0</sub> [V]	I <sub>0</sub> [mA]	P <sub>0</sub> [W]	C <sub>0</sub> [μF]	L <sub>0</sub> [mH]
J2.6 / J3.3	12.6	42	0.53	*	
J2.5 / J3.6	8.7	133	1.16	**	
J2.2 / J3.2	5.36	30	0.040	0.1	0.1
J2.1 / J3.1	5.36	30	0.040	0.1	0.1
APS768x-CL/CL	U <sub>0</sub> [V]	I <sub>0</sub> [mA]	P <sub>0</sub> [mW]	C <sub>0</sub> [μF]	L <sub>0</sub> [mH]
Scale interface S1–S4	7.15	24	43	0.2	0.2
Communication interface C1–C4	7.15	107	270	0.3	0.6
RS232-IS	U <sub>0</sub> [V]	I <sub>0</sub> [mA]	P <sub>0</sub> [mW]	C <sub>0</sub> [μF]	L <sub>0</sub> [mH]
J8.3	±5.36	±18.1	24.2	0.1	0.1
J10.3	±5.36	±18.1	24.2	0.1	0.1
CL ACTIVE	U <sub>0</sub> [V]	I <sub>0</sub> [mA]	P <sub>0</sub> [mW]	C <sub>0</sub> [μF]	L <sub>0</sub> [mH]
J2	5.36	74	397	0.6	0.4
CL PASSIVE	U <sub>1</sub> [V]	I <sub>1</sub> [mA]	P <sub>1</sub> [mW]	C <sub>1</sub> [μF]	L <sub>1</sub> [mH]
J4	10	300	500	0.11	negligible

\* Depending on the power supply connected to J1-2 on the backplane and cable (length) between power supply and terminal

\*\* Depending on the power supply connected to J1-4 on the backplane and cable (length) between power supply and terminal

#### CENELEC approval

Cables in accordance with standards EN60079-25 and EN60079-14 for intrinsically safe circuits.

#### cFM<sub>US</sub> approval

USA: Installation shall be in accordance with ANSI/ISA RP 12.6.01.

Canada: Installation shall be in accordance with the Electrical Code C2.R1.

#### For all approvals

- Cable lead-in via grounding cable gland
- Cable according to Installation manual ME-22026623
- Temperature range: –10 °C ... +40 °C

- 1) Cable 4 x 2 x 0.5 mm<sup>2</sup> + 1 x 0.5 mm<sup>2</sup> shielded and paired
- 2) Cable 2 x 3 x 0.75 mm<sup>2</sup> shielded and paired
- 3) Cable 2 x 2 x 0.5 mm<sup>2</sup> shielded and paired
- 4) Connection of equipotential bonding (EB) in accordance with national regulations.  
It must be ensured that the housing of all units are at the same potential by means of EB connections.  
No compensation current may flow across the shield of the intrinsically safe cables.
- 5) APS768x power supply connection in accordance with national regulations, see model plate for line voltage and frequency. U<sub>m</sub> ≤ 253 V.

- 6) Lay cabling securely so that it does not move and effectively protect it against damage.
- 7) Via internal cables in APS768x.
- 8) The use of Option 1 (Scale 1) is mandatory, either Digital scale or PDC-SG-EX1. For a second scale, the combinations as shown on Sheets 1 to 4 are available.
- 9) Cable seal between differently rated areas, as per country specific regulations.
- 10) Internal cable for a compact scale.
- 11) FM approved for US installations and suitably certified for Canada for Canadian installations.
- 12) Also certified according to NEC505: AEx ib IIC T4; AEx em [ib] IIC T4

B	/	01.12.2015	Varga					
A	/	25.09.2013	Varga		Date	Name	Scale	Designation
Edition	Revision	Date	Name	Prep.	06.05.2013	Varga		Control Drawing ICS466x / ICS426x
				Check	06.05.2013	Lebherz		
Replaces:								Sheet 1/6
METTLER TOLEDO			Mettler-Toledo (Albstadt) GmbH D-72458 Albstadt					Code 22026630

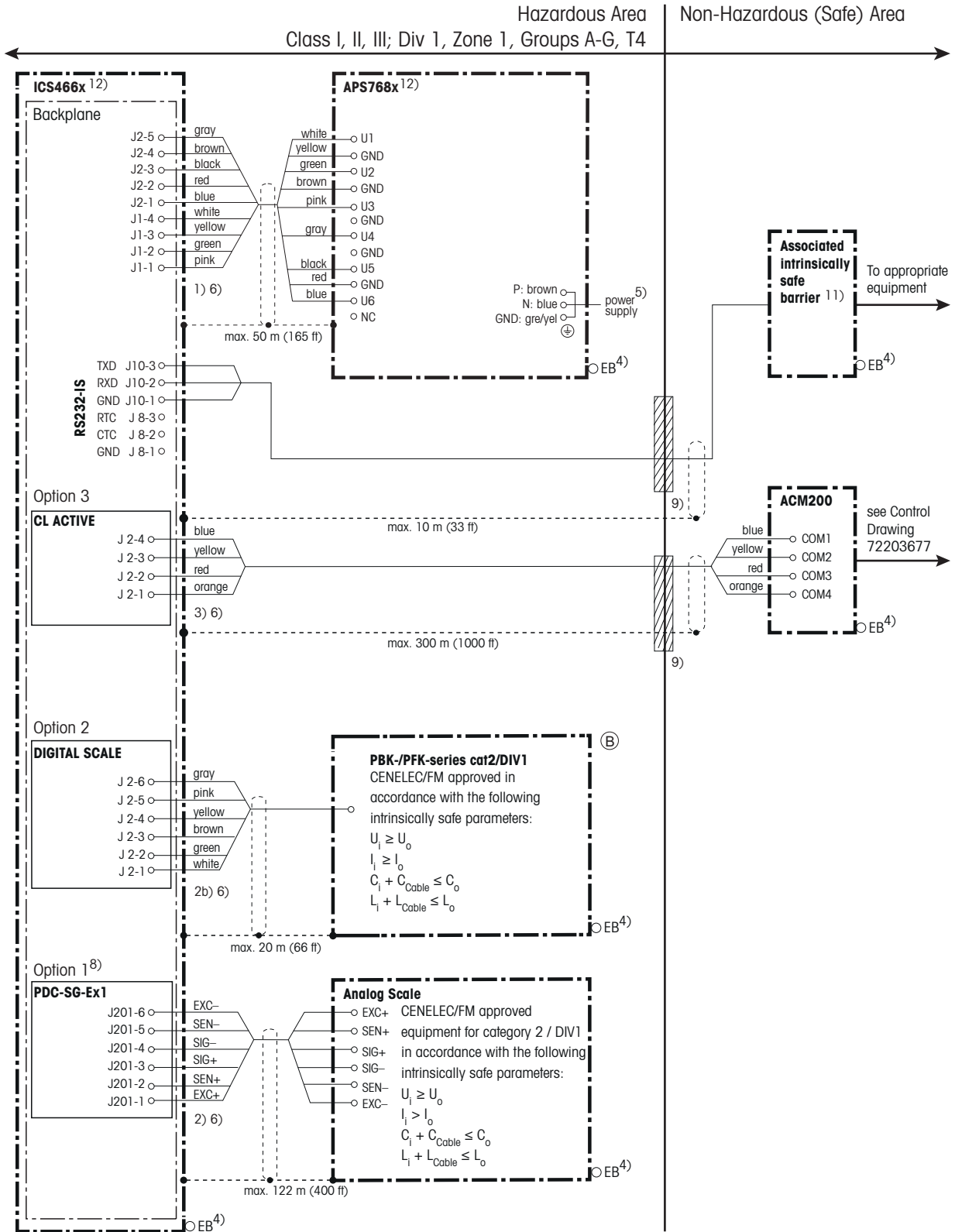

### Intrinsically safe connection values

APS768x	U <sub>0</sub> [V]	I <sub>0</sub> [mA]	P <sub>0</sub> [W]	C <sub>0</sub> [μF]	L <sub>0</sub> [mH]
U1	8.7	133	1.15	1	0.3
U2	12.6	42	0.53	0.4	1
U3	7.15	107	0.77	1	0.3
U4	10.5	74	0.78	0.6	0.3
U5	5.4	240	1.30	1	0.3
U6	12.6	92	1.16	0.5	0.3
PDC-SG-Ex1	U <sub>0</sub> [V]	I <sub>0</sub> [mA]	P <sub>0</sub> [W]	C <sub>0</sub> [μF]	L <sub>0</sub> [mH]
J201	5.36	107	0.574	0.2	0.3
DIGITAL SCALE	U <sub>0</sub> [V]	I <sub>0</sub> [mA]	P <sub>0</sub> [W]	C <sub>0</sub> [μF]	L <sub>0</sub> [mH]
J2.6 / J3.3	12.6	42	0.53	*	
J2.5 / J3.6	8.7	133	1.16	**	
J2.2 / J3.2	5.36	30	0.040	0.1	0.1
J2.1 / J3.1	5.36	30	0.040	0.1	0.1
APS768x-CL/CL	U <sub>0</sub> [V]	I <sub>0</sub> [mA]	P <sub>0</sub> [mW]	C <sub>0</sub> [μF]	L <sub>0</sub> [mH]
Scale interface S1-S4	7.15	24	43	0.2	0.2
Communication interface C1-C4	7.15	107	270	0.3	0.6
RS232-IS	U <sub>0</sub> [V]	I <sub>0</sub> [mA]	P <sub>0</sub> [mW]	C <sub>0</sub> [μF]	L <sub>0</sub> [mH]
J8.3	±5.36	±18.1	24.2	0.1	0.1
J10.3	±5.36	±18.1	24.2	0.1	0.1
CL ACTIVE	U <sub>0</sub> [V]	I <sub>0</sub> [mA]	P <sub>0</sub> [mW]	C <sub>0</sub> [μF]	L <sub>0</sub> [mH]
J2	5.36	74	397	0.6	0.4
CL PASSIVE	U <sub>1</sub> [V]	I <sub>1</sub> [mA]	P <sub>1</sub> [mW]	C <sub>1</sub> [μF]	L <sub>1</sub> [mH]
J4	10	300	500	0.11	negligible

\* Depending on the power supply connected to J1-2 on the backplane and cable (length) between power supply and terminal

\*\* Depending on the power supply connected to J1-4 on the backplane and cable (length) between power supply and terminal

#### CENELEC approval

Cables in accordance with standards EN60079-25 and EN60079-14 for intrinsically safe circuits.

#### cFM<sub>US</sub> approval

USA: Installation shall be in accordance with ANSI/ISA RP 12.6.01.

Canada: Installation shall be in accordance with the Electrical Code C2.R1.

#### For all approvals

- Cable lead-in via grounding cable gland
- Cable according to Installation manual ME-22026623
- Temperature range: -10 °C ... +40 °C

- 1) Cable 4 x 2 x 0.5 mm<sup>2</sup> + 1 x 0.5 mm<sup>2</sup> shielded and paired
- 2) Cable 2 x 3 x 0.75 mm<sup>2</sup> shielded and paired
- 2b) METTLER TOLEDO M12 Ex-i connector / open wires 2 x 2 x 0.25 mm<sup>2</sup> + 2 x 0.25 mm<sup>2</sup> shielded and paired
- 3) Cable 2 x 2 x 0.5 mm<sup>2</sup> shielded and paired
- 4) Connection of equipotential bonding (EB) in accordance with national regulations.  
It must be ensured that the housing of all units are at the same potential by means of EB connections.  
No compensation current may flow across the shield of the intrinsically safe cables.
- 5) APS768x power supply connection in accordance with national regulations, see model plate for line voltage and frequency. U<sub>m</sub> ≤ 253 V.

- 6) Lay cabling securely so that it does not move and effectively protect it against damage.
- 7) Via internal cables in APS768x.
- 8) The use of Option 1 (Scale 1) is mandatory, either Digital scale or PDC-SG-EX1. For a second scale, the combinations as shown on Sheets 1 to 4 are available.
- 9) Cable seal between differently rated areas, as per country specific regulations.
- 10) Internal cable for a compact scale.
- 11) FM approved for US installations and suitably certified for Canada for Canadian installations.
- 12) Also certified according to NEC505: AEx ib IIC T4; AEx em [ib] IIC T4

B	/	01.12.2015	Varga					
A	/	25.09.2013	Varga		Date	Name	Scale	Designation
Edition	Revision	Date	Name	Prep.	06.05.2013	Varga		Control Drawing ICS466x / ICS426x
				Check	06.05.2013	Lebherz		
Replaces:								Sheet 2/6
METTLER TOLEDO			Mettler-Toledo (Albstadt) GmbH D-72458 Albstadt					Code 22026630

7.2

ICS466x with analog and digital scale and a second ICS466x

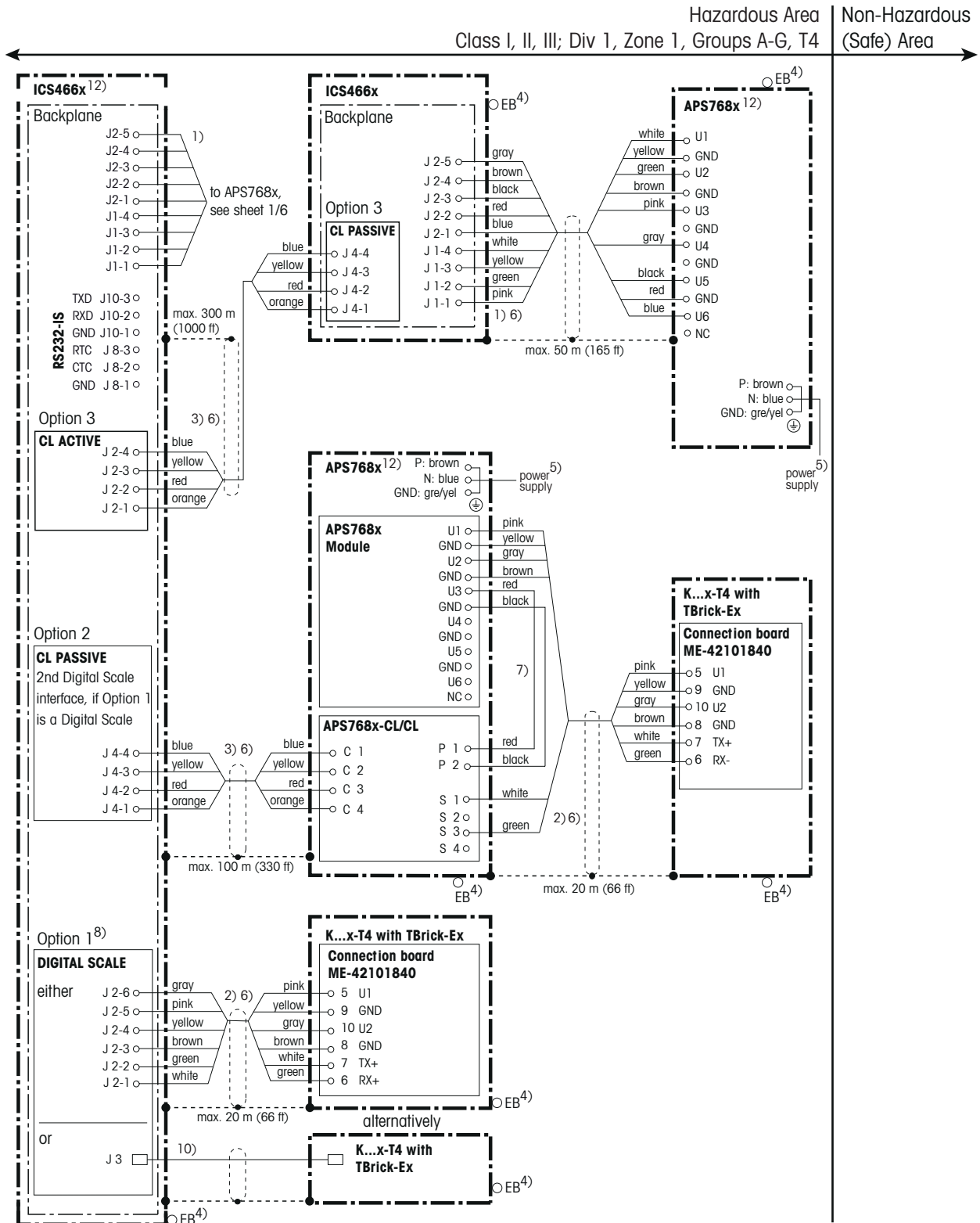

### Intrinsically safe connection values

APS768x	U <sub>0</sub> [V]	I <sub>0</sub> [mA]	P <sub>0</sub> [W]	C <sub>0</sub> [μF]	L <sub>0</sub> [mH]
<b>U1</b>	8.7	133	1.15	1	0.3
<b>U2</b>	12.6	42	0.53	0.4	1
<b>U3</b>	7.15	107	0.77	1	0.3
<b>U4</b>	10.5	74	0.78	0.6	0.3
<b>U5</b>	5.4	240	1.30	1	0.3
<b>U6</b>	12.6	92	1.16	0.5	0.3
PDC-SG-Ex1	U <sub>0</sub> [V]	I <sub>0</sub> [mA]	P <sub>0</sub> [W]	C <sub>0</sub> [μF]	L <sub>0</sub> [mH]
<b>J201</b>	5.36	107	0.574	0.2	0.3
DIGITAL SCALE	U <sub>0</sub> [V]	I <sub>0</sub> [mA]	P <sub>0</sub> [W]	C <sub>0</sub> [μF]	L <sub>0</sub> [mH]
<b>J2.6 / J3.3</b>	12.6	42	0.53	*	
<b>J2.5 / J3.6</b>	8.7	133	1.16	**	
<b>J2.2 / J3.2</b>	5.36	30	0.040	0.1	0.1
<b>J2.1 / J3.1</b>	5.36	30	0.040	0.1	0.1
APS768x-CL/CL	U <sub>0</sub> [V]	I <sub>0</sub> [mA]	P <sub>0</sub> [mW]	C <sub>0</sub> [μF]	L <sub>0</sub> [mH]
<b>Scale interface S1-S4</b>	7.15	24	43	0.2	0.2
<b>Communication interface C1-C4</b>	7.15	107	270	0.3	0.6
RS232-IS	U <sub>0</sub> [V]	I <sub>0</sub> [mA]	P <sub>0</sub> [mW]	C <sub>0</sub> [μF]	L <sub>0</sub> [mH]
<b>J8.3</b>	±5.36	±18.1	24.2	0.1	0.1
<b>J10.3</b>	±5.36	±18.1	24.2	0.1	0.1
CL ACTIVE	U <sub>0</sub> [V]	I <sub>0</sub> [mA]	P <sub>0</sub> [mW]	C <sub>0</sub> [μF]	L <sub>0</sub> [mH]
<b>J2</b>	5.36	74	397	0.6	0.4
CL PASSIVE	U <sub>1</sub> [V]	I <sub>1</sub> [mA]	P <sub>1</sub> [mW]	C <sub>1</sub> [μF]	L <sub>1</sub> [mH]
<b>J4</b>	10	300	500	0.11	negligible

\* Depending on the power supply connected to J1-2 on the backplane and cable (length) between power supply and terminal

\*\* Depending on the power supply connected to J1-4 on the backplane and cable (length) between power supply and terminal

#### CENELEC approval

Cables in accordance with standards EN60079-25 and EN60079-14 for intrinsically safe circuits.

#### cFM<sub>US</sub> approval

**USA:** Installation shall be in accordance with ANSI/ISA RP 12.6.01.

**Canada:** Installation shall be in accordance with the Electrical Code C2.R1.

#### For all approvals

- Cable lead-in via grounding cable gland
- Cable according to Installation manual ME-22026623
- Temperature range: -10 °C ... +40 °C

- 1) Cable 4 x 2 x 0.5 mm<sup>2</sup> + 1 x 0.5 mm<sup>2</sup> shielded and paired
- 2) Cable 2 x 3 x 0.75 mm<sup>2</sup> shielded and paired
- 3) Cable 2 x 2 x 0.5 mm<sup>2</sup> shielded and paired
- 4) Connection of equipotential bonding (EB) in accordance with national regulations.  
It must be ensured that the housing of all units are at the same potential by means of EB connections.  
No compensation current may flow across the shield of the intrinsically safe cables.
- 5) APS768x power supply connection in accordance with national regulations, see model plate for line voltage and frequency. U<sub>m</sub> ≤ 253 V.

- 6) Lay cabling securely so that it does not move and effectively protect it against damage.
- 7) Via internal cables in APS768x.
- 8) The use of Option 1 (Scale 1) is mandatory, either Digital scale or PDC-SG-EX1. For a second scale, the combinations as shown on Sheets 1 to 4 are available.
- 9) Cable seal between differently rated areas, as per country specific regulations.
- 10) Internal cable for a compact scale.
- 11) FM approved for US installations and suitably certified for Canada for Canadian installations.
- 12) Also certified according to NEC505: AEx ib IIC T4; AEx em [ib] IIC T4

B	/	01.12.2015	Varga						
A	/	25.09.2013	Varga		Date	Name	Scale	Designation	
Edition	Revision	Date	Name	Prep.	06.05.2013	Varga		Control Drawing ICS466x / ICS426x	
				Check	06.05.2013	Lebherz			
Replaces:								Sheet 3/6	
METTLER TOLEDO			Mettler-Toledo (Albstadt) GmbH D-72458 Albstadt				Code	22026630	

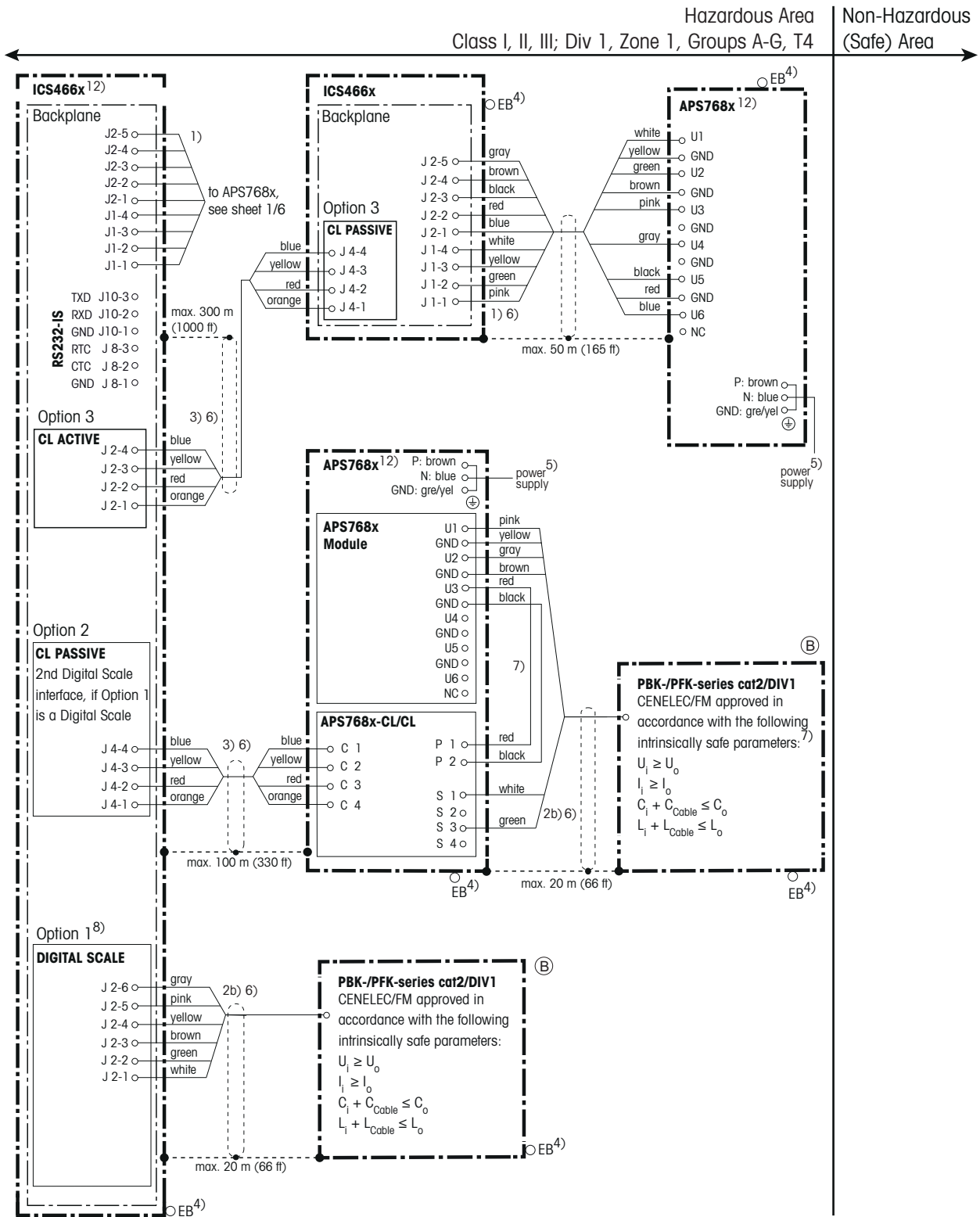



### Intrinsically safe connection values

APS768x	U <sub>0</sub> [V]	I <sub>0</sub> [mA]	P <sub>0</sub> [W]	C <sub>0</sub> [μF]	L <sub>0</sub> [mH]
<b>U1</b>	8.7	133	1.15	1	0.3
<b>U2</b>	12.6	42	0.53	0.4	1
<b>U3</b>	7.15	107	0.77	1	0.3
<b>U4</b>	10.5	74	0.78	0.6	0.3
<b>U5</b>	5.4	240	1.30	1	0.3
<b>U6</b>	12.6	92	1.16	0.5	0.3
PDC-SG-Ex1	U <sub>0</sub> [V]	I <sub>0</sub> [mA]	P <sub>0</sub> [W]	C <sub>0</sub> [μF]	L <sub>0</sub> [mH]
<b>J201</b>	5.36	107	0.574	0.2	0.3
DIGITAL SCALE	U <sub>0</sub> [V]	I <sub>0</sub> [mA]	P <sub>0</sub> [W]	C <sub>0</sub> [μF]	L <sub>0</sub> [mH]
<b>J2.6 / J3.3</b>	12.6	42	0.53	*	
<b>J2.5 / J3.6</b>	8.7	133	1.16	**	
<b>J2.2 / J3.2</b>	5.36	30	0.040	0.1	0.1
<b>J2.1 / J3.1</b>	5.36	30	0.040	0.1	0.1
APS768x-CL/CL	U <sub>0</sub> [V]	I <sub>0</sub> [mA]	P <sub>0</sub> [mW]	C <sub>0</sub> [μF]	L <sub>0</sub> [mH]
<b>Scale interface S1-S4</b>	7.15	24	43	0.2	0.2
<b>Communication interface C1-C4</b>	7.15	107	270	0.3	0.6
RS232-IS	U <sub>0</sub> [V]	I <sub>0</sub> [mA]	P <sub>0</sub> [mW]	C <sub>0</sub> [μF]	L <sub>0</sub> [mH]
<b>J8.3</b>	±5.36	±18.1	24.2	0.1	0.1
<b>J10.3</b>	±5.36	±18.1	24.2	0.1	0.1
CL ACTIVE	U <sub>0</sub> [V]	I <sub>0</sub> [mA]	P <sub>0</sub> [mW]	C <sub>0</sub> [μF]	L <sub>0</sub> [mH]
<b>J2</b>	5.36	74	397	0.6	0.4
CL PASSIVE	U <sub>1</sub> [V]	I <sub>1</sub> [mA]	P <sub>1</sub> [mW]	C <sub>1</sub> [μF]	L <sub>1</sub> [mH]
<b>J4</b>	10	300	500	0.11	negligible

\* Depending on the power supply connected to J1-2 on the backplane and cable (length) between power supply and terminal

\*\* Depending on the power supply connected to J1-4 on the backplane and cable (length) between power supply and terminal

#### CENELEC approval

Cables in accordance with standards EN60079-25 and EN60079-14 for intrinsically safe circuits.

#### cFM<sub>US</sub> approval

**USA:** Installation shall be in accordance with ANSI/ISA RP 12.6.01.

**Canada:** Installation shall be in accordance with the Electrical Code C2.R1.

#### For all approvals

- Cable lead-in via grounding cable gland
- Cable according to Installation manual ME-22026623
- Temperature range: -10 °C ... +40 °C

- 1) Cable 4 x 2 x 0.5 mm<sup>2</sup> + 1 x 0.5 mm<sup>2</sup> shielded and paired
- 2) Cable 2 x 3 x 0.75 mm<sup>2</sup> shielded and paired
- 2b) METTLER TOLEDO M12 Ex-i connector / open wires 2 x 2 x 0.25 mm<sup>2</sup> + 2 x 0.25 mm<sup>2</sup> shielded and paired
- 3) Cable 2 x 2 x 0.5 mm<sup>2</sup> shielded and paired
- 4) Connection of equipotential bonding (EB) in accordance with national regulations.  
It must be ensured that the housing of all units are at the same potential by means of EB connections.  
No compensation current may flow across the shield of the intrinsically safe cables.
- 5) APS768x power supply connection in accordance with national regulations, see model plate for line voltage and frequency. U<sub>m</sub> ≤ 253 V.

- 6) Lay cabling securely so that it does not move and effectively protect it against damage.
- 7) Via internal cables in APS768x.
- 8) The use of Option 1 (Scale 1) is mandatory, either Digital scale or PDC-SG-EX1. For a second scale, the combinations as shown on Sheets 1 to 4 are available.
- 9) Cable seal between differently rated areas, as per country specific regulations.
- 10) Internal cable for a compact scale.
- 11) FM approved for US installations and suitably certified for Canada for Canadian installations.
- 12) Also certified according to NEC505: AEx ib IIC T4; AEx em [ib] IIC T4

B	/	01.12.2015	Varga						
A	/	25.09.2013	Varga		Date	Name	Scale	Designation	
Edition	Revision	Date	Name	Prep.	06.05.2013	Varga		Control Drawing ICS466x / ICS426x	
				Check	06.05.2013	Lebherz			
Replaces:								Sheet 4/6	
METTLER TOLEDO			Mettler-Toledo (Albstadt) GmbH D-72458 Albstadt						Code 22026630

### 7.3 ICS466x with barcode reader

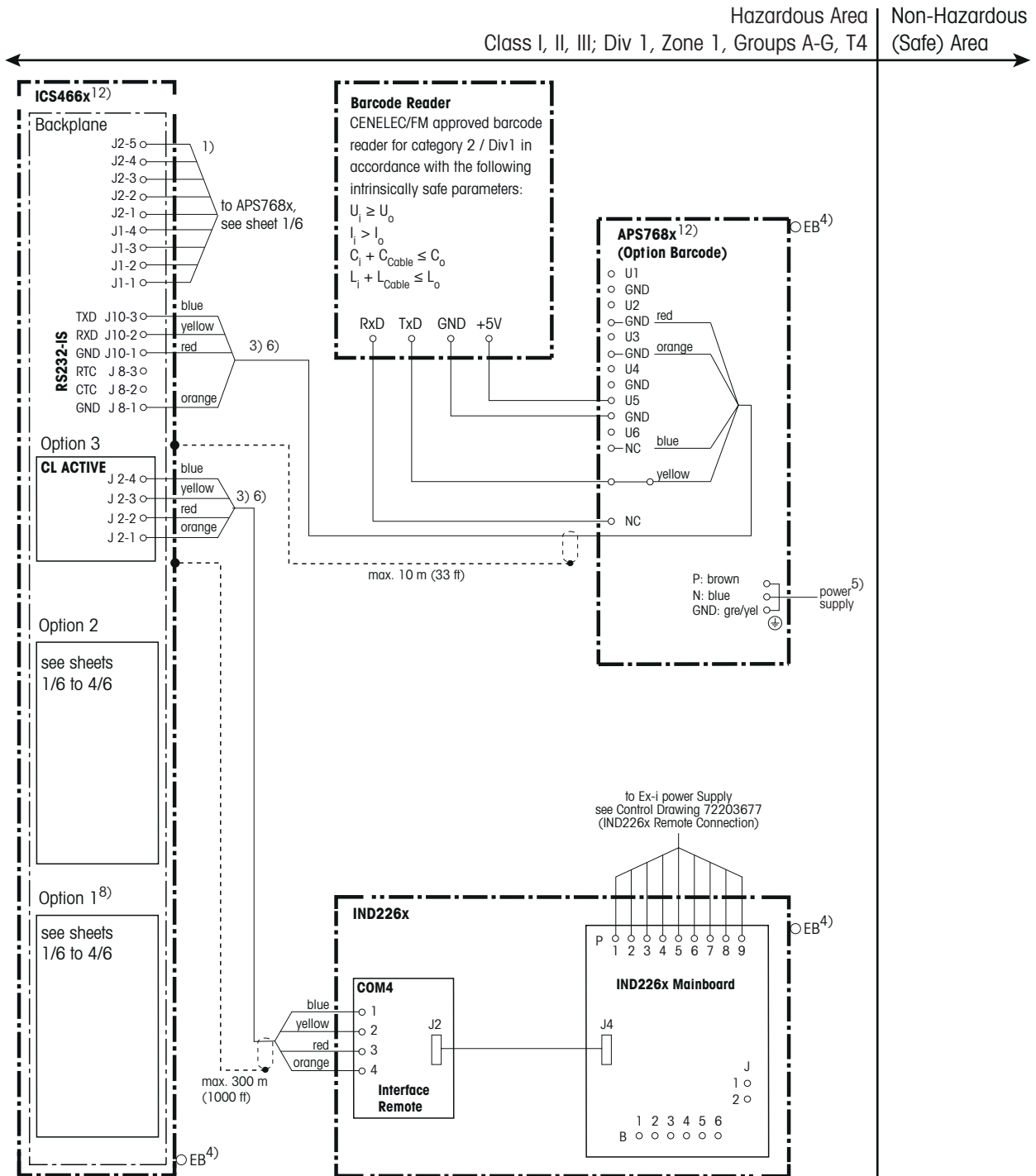

### Intrinsically safe connection values

APS768x	U <sub>0</sub> [V]	I <sub>0</sub> [mA]	P <sub>0</sub> [W]	C <sub>0</sub> [μF]	L <sub>0</sub> [mH]
<b>U1</b>	8.7	133	1.15	1	0.3
<b>U2</b>	12.6	42	0.53	0.4	1
<b>U3</b>	7.15	107	0.77	1	0.3
<b>U4</b>	10.5	74	0.78	0.6	0.3
<b>U5</b>	5.4	240	1.30	1	0.3
<b>U6</b>	12.6	92	1.16	0.5	0.3
PDC-SG-Ex1	U <sub>0</sub> [V]	I <sub>0</sub> [mA]	P <sub>0</sub> [W]	C <sub>0</sub> [μF]	L <sub>0</sub> [mH]
<b>J201</b>	5.36	107	0.574	0.2	0.3
DIGITAL SCALE	U <sub>0</sub> [V]	I <sub>0</sub> [mA]	P <sub>0</sub> [W]	C <sub>0</sub> [μF]	L <sub>0</sub> [mH]
<b>J2.6 / J3.3</b>	12.6	42	0.53	*	
<b>J2.5 / J3.6</b>	8.7	133	1.16	**	
<b>J2.2 / J3.2</b>	5.36	30	0.040	0.1	0.1
<b>J2.1 / J3.1</b>	5.36	30	0.040	0.1	0.1
APS768x-CL/CL	U <sub>0</sub> [V]	I <sub>0</sub> [mA]	P <sub>0</sub> [mW]	C <sub>0</sub> [μF]	L <sub>0</sub> [mH]
<b>Scale interface S1-S4</b>	7.15	24	43	0.2	0.2
<b>Communication interface C1-C4</b>	7.15	107	270	0.3	0.6
RS232-IS	U <sub>0</sub> [V]	I <sub>0</sub> [mA]	P <sub>0</sub> [mW]	C <sub>0</sub> [μF]	L <sub>0</sub> [mH]
<b>J8.3</b>	±5.36	±18.1	24.2	0.1	0.1
<b>J10.3</b>	±5.36	±18.1	24.2	0.1	0.1
CL ACTIVE	U <sub>0</sub> [V]	I <sub>0</sub> [mA]	P <sub>0</sub> [mW]	C <sub>0</sub> [μF]	L <sub>0</sub> [mH]
<b>J2</b>	5.36	74	397	0.6	0.4
CL PASSIVE	U <sub>1</sub> [V]	I <sub>1</sub> [mA]	P <sub>1</sub> [mW]	C <sub>1</sub> [μF]	L <sub>1</sub> [mH]
<b>J4</b>	10	300	500	0.11	negligible

\* Depending on the power supply connected to J1-2 on the backplane and cable (length) between power supply and terminal

\*\* Depending on the power supply connected to J1-4 on the backplane and cable (length) between power supply and terminal

#### CENELEC approval

Cables in accordance with standards EN60079-25 and EN60079-14 for intrinsically safe circuits.

#### cFM<sub>US</sub> approval

**USA:** Installation shall be in accordance with ANSI/ISA RP 12.6.01.

**Canada:** Installation shall be in accordance with the Electrical Code C2.R1.

#### For all approvals

- Cable lead-in via grounding cable gland
- Cable according to Installation manual ME-22026623
- Temperature range: -10 °C ... +40 °C

- 1) Cable 4 x 2 x 0.5 mm<sup>2</sup> + 1 x 0.5 mm<sup>2</sup> shielded and paired
- 2) Cable 2 x 3 x 0.75 mm<sup>2</sup> shielded and paired
- 2b) METTLER TOLEDO M12 Ex-i connector / open wires 2 x 2 x 0.25 mm<sup>2</sup> + 2 x 0.25 mm<sup>2</sup> shielded and paired
- 3) Cable 2 x 2 x 0.5 mm<sup>2</sup> shielded and paired
- 4) Connection of equipotential bonding (EB) in accordance with national regulations.  
It must be ensured that the housing of all units are at the same potential by means of EB connections.  
No compensation current may flow across the shield of the intrinsically safe cables.
- 5) APS768x power supply connection in accordance with national regulations, see model plate for line voltage and frequency. U<sub>m</sub> ≤ 253 V.
- 6) Lay cabling securely so that it does not move and effectively protect it against damage.
- 7) Via internal cables in APS768x.
- 8) The use of Option 1 (Scale 1) is mandatory, either Digital scale or PDC-SG-EX1. For a second scale, the combinations as shown on Sheets 1 to 4 are available.
- 9) Cable seal between differently rated areas, as per country specific regulations.
- 10) Internal cable for a compact scale.
- 11) FM approved for US installations and suitably certified for Canada for Canadian installations.
- 12) Also certified according to NEC505: AEx ib IIC T4; AEx em [ib] IIC T4

B	/	01.12.2015	Varga					
A	/	25.09.2013	Varga		Date	Name	Scale	Designation
Edition	Revision	Date	Name	Prep.	06.05.2013	Varga		Control Drawing ICS466x / ICS426x
				Check	06.05.2013	Lebherz		
Replaces:								Sheet 5/6
METTLER TOLEDO			Mettler-Toledo (Albstadt) GmbH D-72458 Albstadt			Code 22026630		

7.4 ICS426x

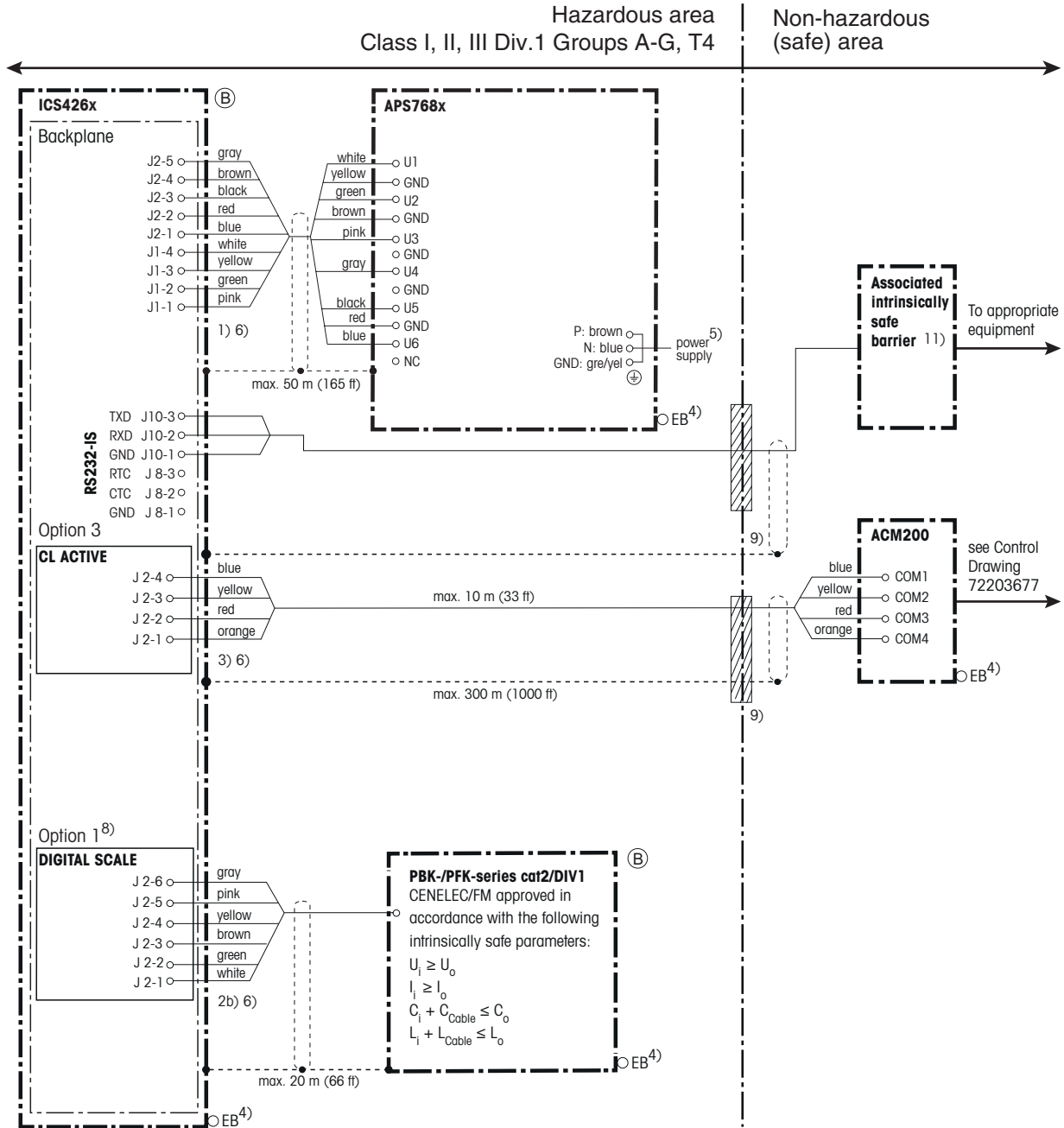

### Intrinsically safe connection values

APS768x	U <sub>0</sub> [V]	I <sub>0</sub> [mA]	P <sub>0</sub> [W]	C <sub>0</sub> [μF]	L <sub>0</sub> [mH]
<b>U1</b>	8.7	133	1.15	1	0.3
<b>U2</b>	12.6	42	0.53	0.4	1
<b>U3</b>	7.15	107	0.77	1	0.3
<b>U4</b>	10.5	74	0.78	0.6	0.3
<b>U5</b>	5.4	240	1.30	1	0.3
<b>U6</b>	12.6	92	1.16	0.5	0.3
PDC-SG-Ex1	U <sub>0</sub> [V]	I <sub>0</sub> [mA]	P <sub>0</sub> [W]	C <sub>0</sub> [μF]	L <sub>0</sub> [mH]
<b>J201</b>	5.36	107	0.574	0.2	0.3
DIGITAL SCALE	U <sub>0</sub> [V]	I <sub>0</sub> [mA]	P <sub>0</sub> [W]	C <sub>0</sub> [μF]	L <sub>0</sub> [mH]
<b>J2.6 / J3.3</b>	12.6	42	0.53		*
<b>J2.5 / J3.6</b>	8.7	133	1.16		**
<b>J2.2 / J3.2</b>	5.36	30	0.040	0.1	0.1
<b>J2.1 / J3.1</b>	5.36	30	0.040	0.1	0.1
APS768x-CL/CL	U <sub>0</sub> [V]	I <sub>0</sub> [mA]	P <sub>0</sub> [mW]	C <sub>0</sub> [μF]	L <sub>0</sub> [mH]
<b>Scale interface S1-S4</b>	7.15	24	43	0.2	0.2
<b>Communication interface C1-C4</b>	7.15	107	270	0.3	0.6
RS232-IS	U <sub>0</sub> [V]	I <sub>0</sub> [mA]	P <sub>0</sub> [mW]	C <sub>0</sub> [μF]	L <sub>0</sub> [mH]
<b>J8.3</b>	±5.36	±18.1	24.2	0.1	0.1
<b>J10.3</b>	±5.36	±18.1	24.2	0.1	0.1
CL ACTIVE	U <sub>0</sub> [V]	I <sub>0</sub> [mA]	P <sub>0</sub> [mW]	C <sub>0</sub> [μF]	L <sub>0</sub> [mH]
<b>J2</b>	5.36	74	397	0.6	0.4
CL PASSIVE	U <sub>1</sub> [V]	I <sub>1</sub> [mA]	P <sub>1</sub> [mW]	C <sub>1</sub> [μF]	L <sub>1</sub> [mH]
<b>J4</b>	10	300	500	0.11	negligible

\* Depending on the power supply connected to J1-2 on the backplane and cable (length) between power supply and terminal

\*\* Depending on the power supply connected to J1-4 on the backplane and cable (length) between power supply and terminal

#### CENELEC approval

Cables in accordance with standards EN60079-25 and EN60079-14 for intrinsically safe circuits.

#### cFM<sub>US</sub> approval

**USA:** Installation shall be in accordance with ANSI/ISA RP 12.6.01.

**Canada:** Installation shall be in accordance with the Electrical Code C2.R1.

#### For all approvals

- Cable lead-in via grounding cable gland
- Cable according to Installation manual ME-22026623
- Temperature range: -10 °C ... +40 °C

- 1) Cable 4 x 2 x 0.5 mm<sup>2</sup> + 1 x 0.5 mm<sup>2</sup> shielded and paired
- 2) Cable 2 x 3 x 0.75 mm<sup>2</sup> shielded and paired
- 2b) METTLER TOLEDO M12 Ex-i connector / open wires 2 x 2 x 0.25 mm<sup>2</sup> + 2 x 0.25 mm<sup>2</sup> shielded and paired
- 3) Cable 2 x 2 x 0.5 mm<sup>2</sup> shielded and paired
- 4) Connection of equipotential bonding (EB) in accordance with national regulations.  
It must be ensured that the housing of all units are at the same potential by means of EB connections.  
No compensation current may flow across the shield of the intrinsically safe cables.
- 5) APS768x power supply connection in accordance with national regulations, see model plate for line voltage and frequency. U<sub>m</sub> ≤ 253 V.
- 6) Lay cabling securely so that it does not move and effectively protect it against damage.
- 7) Via internal cables in APS768x.
- 8) The use of Option 1 (Scale 1) is mandatory, Digital scale.
- 9) Cable seal between differently rated areas, as per country specific regulations.
- 10) Internal cable for a compact scale.
- 11) FM approved for US installations and suitably certified for Canada for Canadian installations.
- 12) Also certified according to NEC505: AEx ib IIC T4; AEx em [ib] IIC T4

B	/	01.12.2015	Varga					
A	/	25.09.2013	Varga		Date	Name	Scale	Designation
Edition	Revision	Date	Name	Prep.	06.05.2013	Varga		Control Drawing ICS466x / ICS426x
				Check	06.05.2013	Lebherz		
Replaces:								Sheet 6/6
/								Code
METTLER TOLEDO			Mettler-Toledo (Albstadt) GmbH D-72458 Albstadt			22026630		

[www.mt.com/support](http://www.mt.com/support)

For more information

**Mettler-Toledo (Albstadt) GmbH**

D-72458 Albstadt

Tel. +49 7431-14 0

Fax +49 7431-14 232

Subject to technical changes

© 11/2016 Mettler-Toledo (Albstadt) GmbH

Printed in Germany

Order number 22026623D



\* 2 2 0 2 6 6 2 3 D \*