

ICS426x

Explosion proof weighing solution

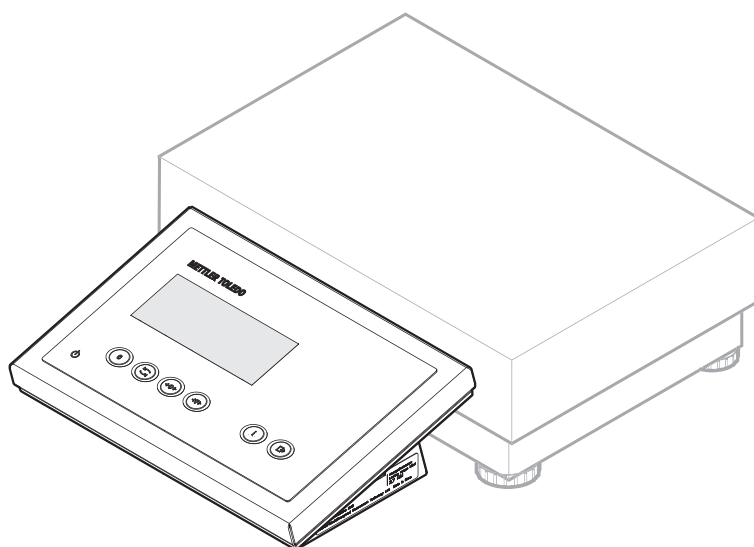

METTLER TOLEDO

METTLER TOLEDO Service

Congratulations on choosing the quality and precision of METTLER TOLEDO. Proper use of your new equipment according to this Manual and regular calibration and maintenance by our factory-trained service team ensures dependable and accurate operation, protecting your investment. Contact us about a service agreement tailored to your needs and budget. Further information is available at www.mt.com/service

There are several important ways to ensure you maximize the performance of your investment:

- 1 **Register your product:** We invite you to register your product at www.mt.com/productregistration so we can contact you about enhancements, updates and important notifications concerning your product.
- 2 **Contact METTLER TOLEDO for service:** The value of a measurement is proportional to its accuracy – an out of specification scale can diminish quality, reduce profits and increase liability. Timely service from METTLER TOLEDO will ensure accuracy and optimize uptime and equipment life.
 - ⇒ **Installation, Configuration, Integration and Training:** Our service representatives are factory-trained weighing equipment experts. We make certain that your weighing equipment is ready for production in a cost effective and timely fashion and that personnel are trained for success.
 - ⇒ **Initial Calibration Documentation:** The installation environment and application requirements are unique for every industrial scale so performance must be tested and certified. Our calibration services and certificates document accuracy to ensure production quality and provide a quality system record of performance.
 - ⇒ **Periodic Calibration Maintenance:** A Calibration Service Agreement provides on-going confidence in your weighing process and documentation of compliance with requirements. We offer a variety of service plans that are scheduled to meet your needs and designed to fit your budget.

Table of Contents

1	Introduction	3
1.1	Safety instructions.....	3
1.2	Presentation.....	4
1.3	Commissioning.....	9
2	Operation	10
2.1	Switching on/off.....	10
2.2	Straight weighing.....	10
2.3	Switching units.....	10
2.4	Zeroing / Zero point correction.....	11
2.5	Weighing with tare.....	11
2.6	Displaying information.....	13
2.7	Printing results.....	13
2.8	Average (dynamic) weighing.....	14
2.9	Working with identifications.....	14
2.10	Cleaning.....	15
2.11	Verification test.....	15
3	Settings in the menu	16
3.1	Menu overview.....	16
3.2	Operating the menu.....	16
3.3	Scale menu block.....	19
3.4	Application menu block.....	24
3.5	Terminal menu block.....	25
3.6	Communication menu block.....	29
3.7	Maintenance menu block.....	32
4	Event and error messages	34
4.1	Error conditions.....	34
4.2	Errors and warnings.....	35
4.3	Smart weighing counter / spanner icon.....	36
4.4	Service information.....	36
5	Technical data	37
6	Appendix	38
6.1	Disposal.....	38
6.2	Protocol printouts.....	38
	Index	39

1 Introduction

1.1 Safety instructions

General

The **ICS426x** weighing terminal is approved for operation in Category 2 / DIV 1 hazardous areas.

If the **ICS426x** weighing terminal is used in hazardous areas, special care must be taken. The code of practice is oriented to the "Safe Distribution" concept drawn up by METTLER TOLEDO.

Competence

- The weighing system may only be installed, maintained and repaired by authorized METTLER TOLEDO service personnel.
- The mains supply may only be installed by a specialist authorized by the owner-operator.

Ex approval

- No modifications may be made to the terminal and no repair work may be performed on the modules. Any weighing platform or system modules that are used must comply with the specifications contained in this manual. Non-compliant equipment jeopardizes the intrinsic safety of the system, cancels the "Ex" approval and renders any warranty or product liability claims null and void.
- The safety of the weighing system is only guaranteed when the weighing system is operated, installed and maintained in accordance with the respective instructions.
- Also comply with the following:
 - the instructions for the system modules,
 - the regulations and standards in the respective country,
 - the statutory requirement for electrical equipment installed in hazardous areas in the respective country,
 - all instructions related to safety issued by the owner.
- The explosion-protected weighing system must be checked to ensure compliance with the requirements for safety before being put into service for the first time, following any service work and every 3 years, at least.

Operation

- Prevent the build-up of static electricity.
 - Always wear suitable working clothes when operating or performing service work in a hazardous area.
 - Only use the weighing terminal when electrostatic processes leading to propagating brush discharges are impossible.
- Prevent the build-up of dust layers.
- Do not use protective coverings for the devices.
- Avoid damage to the system components.

1.2 Presentation

1.2.1 Overview

ICS426x features

- Approved for Category 2 / DIV 1 hazardous areas
- Compact scale

Default equipment

The weighing terminal offers the following interfaces:

- 1 serial interface IS-RS232
- 1 scale interface (SICSpro)

Optional equipment

The weighing terminal can be equipped or retrofitted with an additional interface CL20mA to be connected to the ACM200 interface converter in the safe area.

1.2.2 Display

To meet your special requirements, different display layouts are available in the menu under `Terminal -> Device -> Display -> Display layout`.

Straight weighing display – Default layout

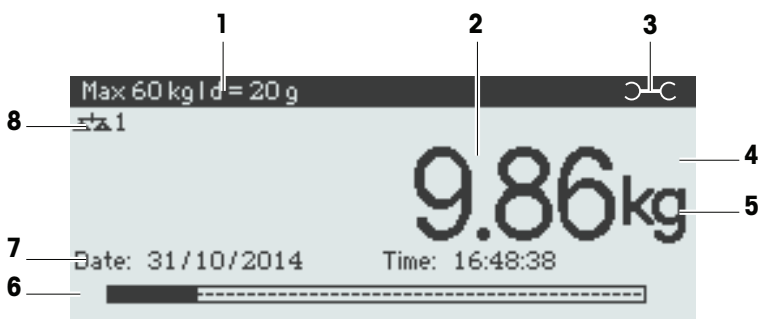

- | | | |
|---|--|--|
| 1 | Metrological data | For details see following table |
| 2 | Weight value with star, sign and stability monitor | For details see following table |
| 3 | Spanner icon: service needed | For details see Event and error messages |
| 4 | Net/Gross | |
| 5 | Unit | |
| 6 | Bargraph | |
| 7 | Auxiliary data line | The content is defined in the menu |
| 8 | Symbol and info line | For details see following table |

Straight weighing display – 3-line mode

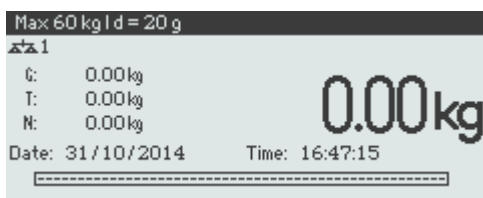

Straight weighing display – Big font mode



Straight weighing display – Bargraph

The device offers a bargraph indicating the scale capacity.



The bargraph indicates roughly which part of the scale capacity is already occupied and what capacity is still available.

In the example above, approximately 3/4 of the scale capacity is occupied, although the applied net weight isn't really high. The reason therefore could be a high tare weight.

Metrological data line

i The metrological data is stored in the weighing platform. The weighing terminal only serves as indicator.

In the metrological data line, the following information is displayed:

Symbol	Information
	Accuracy classes
W1 , W2 , W3	Weighing range information
Max , cap	Maximum capacity
Min	Minimum capacity
e =	Approved resolution
d =	Display resolution
Approved scale	Approved weighing device
-10 °C ... +40 °C	Temperature range



Weight value

The weight value can be marked with the following symbols:





Symbol	Information	Remark
*	Calculated weight value	For example for average weighing results
—	Sign	For negative weight values
○	Stability monitor	For unstable weight values
1.234₃ kg	Non-approved last digit with $e > d$	For approved scales only The example shows the weight value for a scale with $e=1g$ and $d=0.1g$. The last, smaller digit is not approved.

1.2.3 Symbols and info line

In the symbols and info line the following information can be displayed. For more symbols, refer to the User manual.

Symbol	Information	Availability
<->	Weighing range	For multi range or multi interval scales only
	Weight below minimum weight	
	Automatic taring	
	Automatic clearing of the tare weight	
>0<	Center of zero indication	Depending on local Weights and Measures regulations
Fact	Fact needs to be done	Displayed only if the function is supported by the weighing platform, e.g., PBK9-series

1.2.4 Keyboard

Key	Name	Function in the operating mode	Function in the menu
	Power	<ul style="list-style-type: none"> Switching on and off Cancelling editing 	<ul style="list-style-type: none"> Cancelling editing Exiting menu
C	Clear	<ul style="list-style-type: none"> Clearing tare Leaving info page 	<ul style="list-style-type: none"> Clearing value Clearing digit
	Switch	<ul style="list-style-type: none"> Switching over weight unit 	<ul style="list-style-type: none"> Re-editing
	Zero	<ul style="list-style-type: none"> Setting scale to zero Clearing tare 	—
	Tare	<ul style="list-style-type: none"> Taring scale Clearing previous tare 	—
i	Info	<ul style="list-style-type: none"> Activating info screen Proceeding to the next info line / info page Freezing and releasing startup screen 	—
	Transfer	<ul style="list-style-type: none"> Transferring data to a printer or computer 	<ul style="list-style-type: none"> Confirming entry/selection

1.2.5 Connections

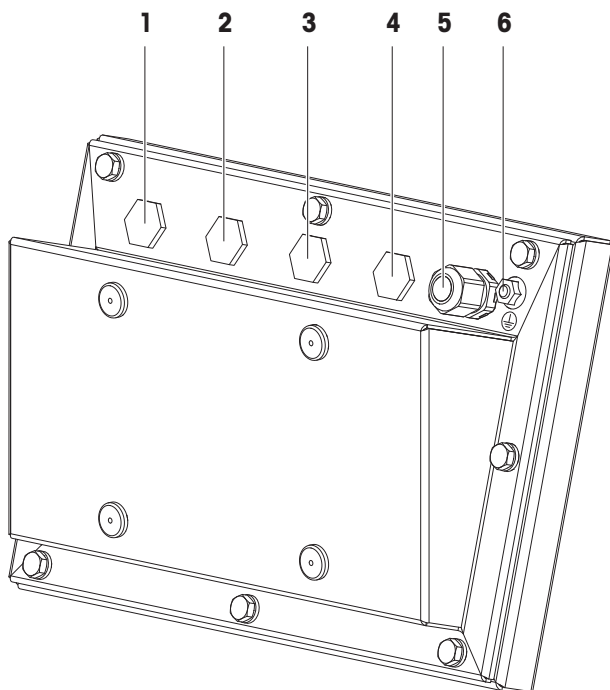

- | | | | |
|----------|---------------------------------------|----------|-------------------------------------|
| 1 | Power supply unit APS768x | 2 | Intrinsically safe RS232 interface |
| 3 | Communication interface | 4 | Blind plug |
| 5 | Weighing platform (analog or digital) | 6 | Equipotential bonding terminal (EB) |



- On connections (1) to (4) blind plugs are mounted at the factory.
- When connecting METTLER TOLEDO devices, M16x1.5 cable glands are provided with the devices.
- The cable gland on connection (5) is provided for connecting an analog weighing platform.

1.3 Commissioning

1.3.1 Selecting the location

The correct location is crucial for the accuracy of the weighing results.

- 1 Select a stable, vibration-free and, if possible, a horizontal location for the weighing platform.
 - ⇒ The ground must be able to safely bear the weight of the fully loaded weighing platform.
- 2 Observe the following environmental conditions:
 - ⇒ No direct sunlight
 - ⇒ No strong drafts
 - ⇒ No excessive temperature fluctuations

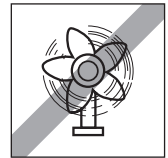
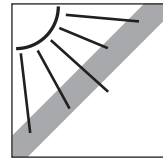
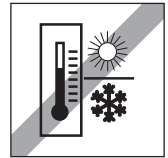
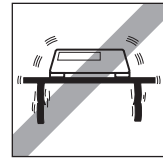

1.3.2 Leveling of weighing platforms

Only weighing platforms that have been levelled precisely horizontally, provide accurate weighing results. Weights and Measures approved weighing platforms have a level bubble to simplify levelling.

- Turn the adjustable feet of the weighing platform until the level bubble's air bubble is inside the inner circle.

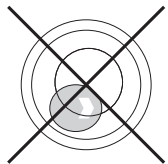
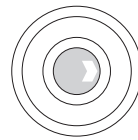

For more details refer to the weighing platform documentation.

2 Operation

2.1 Switching on/off

Switching on

- Press .

⇒ For a few seconds the device shows a start-up screen with device name, software version, serial number of the weighing terminal and the Geo Code value.



- You can freeze the start-up screen by pressing **i**.
- When you start a compact scale, the metrology line shows whether it is approved or not. If you have ordered an approved weighing system, approval has been done in the factory already (not for the US market).
- **To ensure accurate weighing results, wait 15 minutes after switching on before starting weighing operation.**

Switching off

- Press .

⇒ Before the display goes out, **-OFF-** appears briefly.

Resetting

- Press and hold  for approx. 5 seconds.

⇒ The device is switched off.

2.2 Straight weighing

- 1 Place weighing sample on the scale.
- 2 Wait until the stability monitor  disappears.
- 3 Read the weighing result.

2.3 Switching units

If an additional second weight unit is configured in the menu, it is possible to switch back and forth between the two weight units.

- Press .

⇒ The weight value is displayed in the second unit.



- Possible units are g, kg, oz, lb, lb-oz, t.
- When in the menu `Scale -> Disp. unit & res. -> Unit roll` is set to `On`, the weight value can be displayed in all available weight units by repeatedly pressing .

2.4 Zeroing / Zero point correction

Zeroing corrects the influence of slight changes on the load plate or minor deviations from the zero point.

Manual

- 1 Unload scale.
- 2 Press **→0←**.
⇒ Zero appears in the display.

Automatic

In case of non-approved scales, the automatic zero point correction can be deactivated in the menu or the zero range can be changed. Approved scales are set fixed at 0.5 d per second.



- The zero function is only available within a limited weighing range.
- After zeroing the scale, the whole weighing range is still available.

2.5 Weighing with tare

2.5.1 Taring

- Place the empty container on the scale and press **→T←**.
⇒ The zero display and the symbol **NET** appear.
⇒ The tare weight remains stored until it is cleared.

2.5.2 Clearing the tare

- Press **C**.
⇒ The symbol **NET** goes out, the gross weight appears in the display.



If the symbol  is displayed, i.e., the tare function `Auto clear tare` is activated in the `Scale` menu, the tare weight is automatically cleared as soon as the scale is unloaded.

2.5.3 Automatic clearing the tare

A tare weight is automatically cleared when the scale is unloaded.

Prerequisite

The symbol  is displayed, i.e., the tare function `Auto clear tare` is activated in the `Scale` menu.



The tare weight must be heavier than 9 scale divisions.

2.5.4 Automatic taring

If you place a weight on an empty scale, the scale tares automatically and the symbol **NET** is displayed.

Prerequisite

The symbol  is displayed, i.e., the tare function `Auto tare` is activated in the `Scale` menu.



The weight to be tared automatically, e.g., packaging material, must be heavier than 9 scale divisions.

2.5.5 Chain tare

With this function it is possible to tare several times if, e.g., cardboard is placed between individual layers in a container.

- The tare function `Chain tare` is activated in the `Scale` menu.
- 1 Place the first container or packaging material on the scale and press **→T←**.
 - ⇒ The packaging weight is automatically saved as the tare weight, the zero display and the symbol **NET** appear.
 - 2 Load the sample and read/print out the result.
 - 3 Place the second container or packaging material on the scale and press **→T←** again.
 - ⇒ The total weight on the scale is saved as the new tare weight. The zero display appears.
 - 4 Load the sample in the second container and read/print the result.
 - 5 Repeat steps 3 and 4 for other containers.

2.5.6 Tare preset

For established container weights enter the tare weight numerically or via barcode / SICS command. Thus, you do not have to tare the empty container.



The entered tare weight is valid until a new tare weight is entered or the tare weight is cleared.

Tare preset with barcode entry

- For barcode use, `Tare preset` is selected as destination for external input in the menu under `Communication -> COMx -> External input -> Destination`.
- 1 Enter the known tare weight via barcode.
 - ⇒ The weight display shows the negative tare weight and the symbol **NET** appears.
 - 2 Place the full container on the weighing platform.
 - ⇒ The net weight is displayed.

Tare preset with SICS command from a connected computer

- 1 Enter the known tare weight on the computer using the SICS command `TA_Value_Unit`.
 - ⇒ The weight display shows the negative tare weight and the symbol **NET** appears.
- 2 Place the full container on the weighing platform.
 - ⇒ The net weight is displayed.

2.6 Displaying information

Up to 5 different items can be configured in the menu for the **i** key. Depending on the configuration in the menu under `Terminal -> Device -> Keyboard -> Info key`, the following data can be assigned in any order, e.g.,

- Date & Time
- Weight values
- Identifications
- Article information
- Application parameters
- Device information
- Serial numbers and software versions

On the second and third info page, system and contact information can be displayed.

- 1 Press **i**.
⇒ The (first) info page is displayed.
- 2 Press **i** again.
⇒ The next info screen is displayed.
- 3 To leave the info screens, press **C**.

i An info screen is displayed until **i** is pressed again or until **C** is pressed.

2.7 Printing results

- i**
- The printer or computer has to be located in the safe area.
 - The data have to be transferred to the safe area via the ACM200 interface converter.

- Press .
- ⇒ The defined data is printed out or transferred to the computer.

i The printout content can be defined in the menu under `Communication -> COMx -> Define Templates`. The template has to be assigned to the printout in the `Application` menu.

Printing without pressing a key (clever print)

- In the menu `Application -> Clever print -> Activate` is set to `On`.
 - To initiate the next printout, the weight must drop below the set threshold.
- 1 Put the weighing sample on the load plate.
⇒ When a stable weight value is reached, the result is printed automatically.
 - 2 Remove the weighing sample from the load plate and load the next weighing sample.
⇒ When the weight value has dropped below the set threshold, the next stable weight value is printed automatically.

2.8 Average (dynamic) weighing

With the average weighing function, it is possible to weigh moving weighing samples such as animals. If this function is activated,  is displayed in the info line. With average weighing, the scale calculates the mean value from weighing operations within a certain time interval.

Start via hard key

- Application -> Average Weighing -> Mode -> Print key (factory setting), Info key or Switch key is selected in the menu.
- Weighing sample heavier than 9 scale divisions.
 - 1 Place the weighing sample on the scale.
 - 2 Press the key defined in the menu to start average weighing.
 - ⇒ During average weighing, stars appear in the display, and the average result will be displayed with the symbol *****.
 - 3 Unload the scale to begin a new average weighing operation.

With automatic start

- Application -> Average -> Mode -> Auto is selected in the menu.
- Weighing sample heavier than 9 scale divisions.
 - 1 Place the weighing sample on the scale.
 - ⇒ Average weighing starts automatically.
 - ⇒ During average weighing, stars appear in the display, and the average result will be displayed with the symbol *****.
 - 2 Unload the scale to start a new average weighing operation.

2.9 Working with identifications

Weighing series can be assigned with 3 identification numbers ID1, ID2 and ID3 with up to 40 numeric characters that are also printed out in the protocols. If, for example, a customer number and a batch number are assigned, it can be clearly seen in the protocol which batch was weighed for which customer.

Barcode use (for one identification only)

- ID1, ID2 or ID3 is selected as destination for external input in the menu under Communication -> COMx -> External input -> Destination.
- To display the identification in the auxiliary line, ID1, ID2 or ID3 has to be activated in the menu under Terminal -> Display -> Auxiliary line.
- Scan the ID.
 - ⇒ The ID is assigned to the following weighings until a new ID is scanned.

Using SICS command set (up to three identifications)

- To display the identification in the auxiliary line, ID1, ID2 or ID3 has to be activated in the menu under Terminal -> Display -> Auxiliary line.
- Send the ID command (I12, I13 or I14) from a PC.
 - ⇒ The ID is assigned to the following weighings until a new ID is sent.

2.10 Cleaning



WARNING

Explosion hazard

- 1 Strictly observe the instructions of the operating company.
- 2 Avoid electrostatic charging by wearing suitable working clothes when operating in hazardous areas.

Notes on cleaning

- Only use a clean damp cloth and gently wipe the keypad.
- Use water or mild, non-abrasive cleaning agents.
- Do not spray cleaner directly on the weighing terminal.
- Do not use any acids, alkalis or strong solvents.
- Do not clean the weighing terminal using high-pressure or high-temperature water.
- Observe all existing regulations on cleaning intervals and permissible cleaning agents.
- Do not use compressed air or vacuum.
- Remove dust layers.

2.11 Verification test

The weighing instrument is verified if:

- the accuracy class is displayed in the metrological line,
- the approval readability is shown with "e = readability",
- it bears an official verification mark,
- the validity is not expired.

The weighing instrument is also verified if:

- the metrological line shows "Approved scale",
- labels with the metrological data are placed near the weight display,
- the securing seal is not tampered with,
- it bears an official verification mark,
- the validity is not expired.

 The period of validity is country-specific. It is in the responsibility of the owner to renew verification in due time.

3 Settings in the menu

3.1 Menu overview

In the menu, settings can be changed and functions can be activated. This enables adaptation to individual weighing requirements.

The menu consists of the following 5 main blocks containing various submenus on several levels which are described in the following sections.



- Scale
- Application
- Terminal
- Communication
- Maintenance

3.2 Operating the menu



3.2.1 Calling up the menu and entering the password

The menu differentiates between 2 operating levels: Operator and Supervisor. The Supervisor level can be protected by a password. When the device is delivered, both levels are accessible without a password.

Operator menu

- 1 Press  and keep it pressed until **Enter code** appears.
- 2 Press  again.
 - ⇒ The menu item `Terminal` is displayed. Only parts of the submenu `Device` are accessible.

Supervisor menu

- 1 Press  and keep it pressed until **Enter code** appears.
- 2 Enter the password and confirm with .
- ⇒ The first menu item `Scale` is highlighted.



- By default, no password is set. Therefore, confirm the password inquiry with  when you call up the menu for the first time.
- As long as no supervisor password is defined, operator access will offer the complete supervisor menu.
- If a password is not entered within a few seconds, the scale returns to the weighing mode.

Emergency password for Supervisor access to the menu

If a password has been issued for Supervisor access to the menu and you have forgotten it, you can still enter the menu:

- Press **→0←** three times and confirm with .

3.2.2 Display in the menu

Menu items are displayed together with their context.

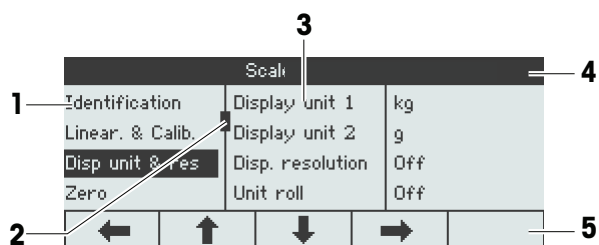

- 1 Menu items; the selected menu item is highlighted
- 2 Scroll flag, like, e.g., the scroll bar of your PC
- 3 Sub-menu items
- 4 Menu info line, i.e., menu path of the current menu item
- 5 Navigation info line: use the keys below to navigate the menu as indicated

Exiting the menu

- Press .
- ⇒ **Save settings?** is displayed.
- Press the key to save the menu changes and to return to the weighing mode.
- or
- Press the key for further menu settings.
- or
- Press the key to discard changes and return to the weighing mode.

3.2.3 Selecting and setting parameters in the menu

Example: Setting the average weighing mode to "Automatic"

- 1 In the menu start screen use to select (highlight) the `Application` menu.
The submenus are displayed in the middle column.
- 2 Press to enter the `Application` menu.
The submenus are displayed in the middle column.
- 3 Press and then press to open the `Avg. weighing` submenu.
The current setting of the highlighted menu item is displayed in the right column.
- 4 Press to enter the `Mode` submenu.
The possible settings of the selected menu item are displayed on the right side.
- 5 Press to select (highlight) `Auto` and confirm selection with .
The setting of the average weighing mode has changed.

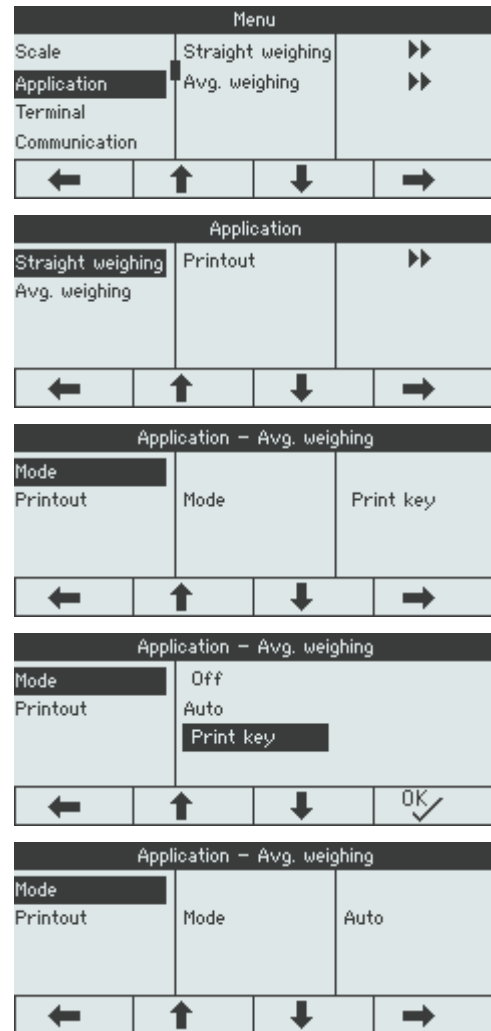

i Should the settings of a menu item not be displayed on one page (e.g., all the info items), use to proceed to the hidden items.

3.3 Scale menu block

3.3.1 Scale menu overview

The `Scale` menu depends on the connected load cell.

The **ICS426x**-series is available as a compact scale with PBK9-series weighing platforms with SICSpro scale interface.

3.3.2 Scale menu block (Analog / SICSpro)

Overview

Factory settings are printed in **bold** in the following overview.

Level 1	Level 2	Level 3	Level 4
Identification	Serial no. scale, Scale model, Scale location, Scale ID		
Linear. & Calib.	Last calibration		
	Start up FACT (for SICSpro scales only)	On , Off	
	Auto print calib.	On , Off	
	Perform calib.		
Disp. unit & res.	Display unit 1	g, kg , oz, lb, lb-oz, t	
	Display unit 2	g , kg, oz, lb, lb-oz, t	
	Disp. resolution		
	Unit roll	On, Off	
Zero	AZM	Off, 0.5d , 1d, 2d, 5d, 10d	
Tare	Auto tare	On, Off	
	Chain tare	On , Off	
	Auto clear tare	On, Off	
Restart	On, Off		
Filter	Vibration	Low, Medium , High	
	Process	Universal , Dosing, Absolute	
	Stability	Fast, Standard , Precise	
MinWeigh	MinWeigh	On, Off	
FACT (for SICSpro scales only)	Temperature	Off, 1K, 2K, 3K	
	Time	Time 1, Time 2, Time 3	
	Days	Monday ... Sunday	Off , On
Reset	Perform reset?		

Description

Identification	Displaying/setting scale identification data
Serial no. scale	Displaying the serial number of the weighing platform
Scale model	Displaying the scale type, e.g., PBK9/PFK9 weighing platforms Available for METTLER TOLEDO scales only
Scale location	Entering the scale location, e.g., floor and room
Scale ID	Entering the scale identification, e.g., inventory number
Notes	<ul style="list-style-type: none"> Scale location and Scale ID can be displayed in the auxiliary or info lines or printed out. Scale location and Scale ID can consist of up to 24 alphanumeric characters.

Linear. & Calib	Linearization and calibration
Last calibration	Shows the date of the last calibration.
Start up FACT	When set to On , an internal calibration is performed every time the scale is switched on. It is recommended not to disable this setting if the scale will be moved to other locations.
Autoprint calib.	When set to On , a protocol is printed out automatically for each calibration process.
Perform calib.	<p>Important: With PBK9/PFK9 weighing platforms make sure that the scale has been switched on at least 15 minutes before performing linearization/calibration.</p> <ol style="list-style-type: none"> Start calibration with <input type="text" value="OK"/>. ⇒ Preload is blinking. Ensure that the weighing platform is empty and confirm with <input type="text" value="OK"/>. If necessary, change the calibration weight value displayed using <input type="text" value="↓"/> / <input type="text" value="↑"/>. Put on the indicated calibration weight on the weighing platform and confirm with <input type="text" value="OK"/>. Remove the calibration weight and confirm with <input type="text" value="OK"/>. <p>⇒ Passed is displayed briefly.</p>
Notes	<ul style="list-style-type: none"> In order to achieve a particularly high precision, calibrate under full load. The calibration process can be aborted using <input type="text" value="ESC"/>. This menu item is not available for verified scales.

Disp. unit & res.	Display units and resolution
Display unit 1	Selecting weighing unit 1
Display unit 2	Selecting weighing unit 2, different from unit 1
Display resolution	Selecting readability (resolution). The possible settings depend on the connected scale. When set to <code>Off</code> , only the default resolution of the weighing platform is available.
Unit roll	When set to <code>On</code> , the weight value can be displayed in all available units with  .
Notes	<ul style="list-style-type: none"> In case of verified scales, individual sub-items of the <code>Display/Units & Resolution</code> menu item may not be available or only to a limited extent, depending on the respective country. On dual-range/dual interval scales, resolutions marked with <code>l<->l 1/2</code> are divided into 2 weighing ranges/intervals, e.g., 2 x 3000 d. On triple-range/multi interval scales, resolutions marked with <code>l<->l 1/2/3</code> are divided into 3 weighing ranges/intervals, e.g., 3 x 3000 d.

Zero	Automatic zero setting
AZM	Automatic Zero Maintenance
On/Off	Switching automatic zero maintenance on/off.
Off; 0.5 d; 1 d; 2 d; 5 d; 10 d	Selecting zeroing range in digits per second.
Note	On verified scales, this menu item does not appear.

Tare	Tare function
Auto tare	Switching on/off automatic taring <code>Auto tare = On</code> : When a load is placed on the scale and the gross weight exceeds 9 d, the weight is tared automatically.
Chain tare	Switching on/off chain tare <code>Chain tare = On</code> : It is possible to tare several times if, e.g., cardboard is placed between individual layers in a container.
Auto clear tare	Switching on/off automatic clearing of the tare weight <code>Auto clear tare = On</code> : When the load is removed and the weight drops below 9 d, the tare weight is cleared automatically.

Restart	Automatic saving of zero point and tare value
Restart	When set to <code>On</code> , the last zero point and the tare value are saved. After switching off/on or after a power interruption, the device continues to work with the saved zero point and tare value.

Filter	Filter settings
Vibration	Adaptation to ambient conditions
Low	Very steady and stable environment. The scale works very rapidly, but is very sensitive to external influences.
Medium	Normal environment. The scale operates at medium speed.
High	Unstable environment. The scale works more slowly, but is less sensitive to external influences.
Process	Adaptation to the weighing process
Universal	Universal setting for all weighing samples and normal weighing goods.
Dosing	Dispensing liquid or powdery weighing samples (only for certain weighing platforms, e.g., PBK9-series / PFK9-series).
Absolute	For solid bodies under extreme conditions, e.g., strong vibrations.
Stability	Adjusting the stability detector
	The slower the scale works, the greater the reproducibility of the weighing results.
Fast	The scale operates very fast.
Standard	The scale operates at medium speed.
Precise	The scale operates with the greatest possible reproducibility.

MinWeigh	MinWeigh function
MinWeigh	Switching MinWeigh function on/off When set to On and if the weight on the scale drops below the stored minimum weight, M will appear in the symbols and info line.
Note	Before you can use this function, the METTLER TOLEDO service technician has to determine and enter a minimum weight value.

FACT	Fully automatic calibration test
Temperature	Setting the temperature difference for automatic adjustment.
Off	Switching off automatic adjustment in case of a temperature difference.
1K, 2K, 3K	Automatic adjustment in case of the selected temperature change.
Time	Setting up to 3 times per day for automatic adjustment.
Time 1, Time 2, Time 3	Entering the times for the automatic adjustment (hours, minutes in 24 h format). To deactivate Time 2 and Time 3, set them to 00:00:00.
Days	Setting the days of the week for automatic adjustment.
Monday ... Sunday	On all days which are set to On , the automatic adjustment will be performed.
Note	FACT is executed under the following conditions: <ul style="list-style-type: none"> No key has been pressed for 3 minutes. – and – The displayed weight value is smaller than 30 d and stable.



Reset	Resetting the scale settings to factory settings
Perform reset?	<p>– Confirm with <input type="checkbox"/>OK✓ to reset the scale menu settings.</p> <p>For SICSprou scales only</p> <ol style="list-style-type: none"> 1 Press Reset for 5 seconds. <ul style="list-style-type: none"> ⇒ Reset User Calibration is displayed. 2 Confirm with <input type="checkbox"/>OK✓ to reset the user calibration.

3.4 Application menu block

3.4.1 Application → Straight weighing

Printout	Defining printer and template in the straight weighing application
COM1, COM2	Selecting the COM port for the desired printer via ACM200 E.g., COM1 for printout to a PC and the optional COM2 for printout on an office (ASCII) printer
Off	No printout on this COM port
Standard	Printout with the standard template on the selected printer
Template 1 ... Template 5	Assigning a customer template to the selected printer
Notes	<ul style="list-style-type: none"> • Templates 1 ... 5 can be defined under <code>Communication</code> → <code>Define templates</code>. • This menu item is only available if a COM port is set to Print mode. • There are 5 more templates available (Template 6 ... Template 10). Please ask your METTLER TOLEDO service technician to configure these templates or create them by yourself using the DatablCS software (www.mt.com/ind-datablcs), if desired.

3.4.2 Application → Average weighing

Mode	Selecting mode for determining the average weight for an unstable load (dynamic weighing)
Auto	Calculating average weight with automatic start of the weighing cycle
Print key Info key Switch key	Calculating average weight with manual start of the weighing cycle via the selected key: Print key  , Info key  , Switch key 
Printout	Defining printer and template in the average weighing application
	See Application → Straight weighing

3.4.3 Application → Clever print

Clever print	Settings for printing without pressing a key
Activate	When set to <code>On</code> , the result is automatically printed when the weight between two weighings has dropped below the threshold.
Threshold	Enter threshold for unloading the scale between two weighings. Possible settings: 0.0 kg ... max. capacity Factory setting: 0.0 kg

3.4.4 Application → Reset

Reset	Resetting the application settings to factory settings
Perform reset?	– Confirm resetting with <input type="checkbox"/>  .

3.5 Terminal menu block

3.5.1 Terminal menu overview

The `Terminal` menu block consists of the following main subblocks, which are described in detail in the following.

- Device
- Access
- Reset

Factory settings are printed in **bold** in the following overview.

3.5.2 Terminal → Device

Overview

Level 1	Level 2	Level 3	Level 4	Level 5	
Region	Language	English , US English, Deutsch, Français, Italiano, Español, Chinese, ...			
	Date format	MM/DD/YY, MM/DD/YYYY, MMM/DD/YYYY, DD/MM/YY, DD/MMM/YYYY, YY/MM/DD, YYYY/MMM/DD, YYYY/MM/DD, DD/MM/YYYY			
	Set date	Set year			
		Set month			
		Set day			
	Time format	24:MM, 12:MM tt, 24:MM:SS , 12:MM:SS tt			
Set time	Set hour				
	Set minutes				
Energy save	Backlight	On , 5 seconds, 10 seconds, 15 seconds, 30 seconds			
	Power off	Off , 1 minute, 3 minutes, 5 minutes, 15 minutes, 30 minutes			
Identification	Terminal loc.				
	Terminal ID				
Display	Display layout	Default , 3-lines mode, Big font mode			
	Contrast	1 ... 5 ... 10			
	Brightness	1 ... 5 ... 10			
	Weight hold	0 (s) ... 10 (s)			
	Auxiliary line	Not used, Date & Time (for battery devices incl. remaining capacity in % and in hours), Gross, Net, Tare, High resolution (not available for approved scales), ID1, ID2, ID3, Bargraph, Temperature			
Keyboard	Hard keys	Power, Clear, Switch, Info, Transfer, Numeric keys	On , Off		
		Info key	Page 1	Item 1 ... Item 5	Not used, Date & Time , Highres & net (not available for approved scales), Gross, Net, Tare, ID1, ID2, ID3, Terminal ID, Terminal loc., Terminal model, SNo. Terminal, Terminal FW, SNo. Scale, Scale FW, Temperature, MinWeigh, Consecutive number
		Page 2 & 3	Info page 2	Off, System info , Contact info	
			Info page 3	Off , System info, Contact info	
	Beeper	On , Off			

Level 1	Level 2	Level 3	Level 4	Level 5
Message time	1 s, 2 s, ... 6 s			
Battery	Charge strategy	Full, Preservation		
Timeout	Mode	Off, Rental, Rental info		
	Set date	Set year, Set month, Set day		



Description

Region	Country specific settings
Language	Selecting the language of the operator interface. We will expand the available languages continuously.
Date format	Selecting the date format.
Set date	Entering the date in the selected format.
Set month	Entering the month in the selected format.
Set day	Entering the day in the selected format.
Time format	Selecting the time format.
Set time	Entering the time in the selected format.
Set hour	Entering the hour in the selected format.
Set minutes	Entering the minutes.

Energy save (Operator access)	Setting the energy saving mode
Backlight	Settings for switching off the backlighting
On	Backlight always on
5 seconds ... 30 seconds	Selecting the time period after which the device switches off display and backlighting when not in use and gross weight is 0. Display and backlighting are switched on again by pressing a key or if the weight changes.
Power off	Settings for switching off the device
Off	No energy saving mode
1 minute ... 30 minutes	Selecting the time period after which the device switches off when not in use and gross weight is 0. After this, it must be switched on again using  .

Identification	Setting terminal identification data
Terminal location	Entering the terminal location, e.g., floor and room
Terminal ID	Entering the terminal identification, e.g., inventory number
Notes	<ul style="list-style-type: none"> Terminal location and terminal identification can be displayed in the auxiliary or info lines or printed out. Terminal location and terminal identification can consist of up to 12 characters (0 ... 9 and decimal point).

Display	Setting the display according to your specific task
Display Layout	Selecting the presentation of the weight value.
Contrast (Operator access)	Setting the contrast of the display. This menu item is accessible with Operator access rights.
Brightness (Operator access)	Setting the brightness of the display. This menu item is accessible with Operator access rights.
Weight hold	Setting how long (in seconds) the weighing result is frozen in the display after the transfer key  has been pressed or auto print was generated.
Auxiliary line	Selecting the contents of the auxiliary display line.

Keyboard	Setting the keyboard according to your specific task
Hard keys	Locking/unlocking keys Possible keys: Power (), Clear (C), Switch / Toggle (), Info (i), Transfer ()
Info key	Configuring the items to be displayed using the info key (i)
Page 1	On the first page of the info key up to 9 information items on the weighing process can be configured. 1 Select item number. 2 Assign information.
Page 2, Page 3	On pages 2 and 3 system and contact information will be displayed. In case of a problem, here you will find your contact data and the system information the service technician will ask for. System information is set by the manufacturer, contact information can be entered directly.
Beeper	When set to On, each keystroke will be confirmed by a short beep.

Message time	Setting how long a message is displayed
1, 2, 3, 4, 5, 6	Setting how long a message is displayed in seconds

Time out	Setting the behaviour when no action takes place on the terminal
Mode	Setting the time out mode.
Off	No time out setting.
Rental	The scale can only be used until a set date, e.g., when the scale is rented for a special event like a fair or a market. After the expiration date a message is displayed: Rental expired and the scale can no longer be used.
Rental info	When the set date has passed, a message is displayed: Rental expired . By pressing the key C , the message is cleared and the scale can be used as before.
Set date	Entering the expiration date.
Set year	Entering the year of the expiration date.
Set month	Entering the month of the expiration date.
Set day	Entering the day of the expiration date.

3.5.3 Terminal → Access

Supervisor	Password for Supervisor menu access
Password	Enter password for Supervisor menu access.
Retype password	Repeat the password entry.
Note	The password can consist of up to 4 characters.

3.5.4 Terminal → Reset

Reset	Resetting the terminal settings to factory settings
Perform reset?	– Confirm resetting with <input type="checkbox"/> ^{OK} <input type="checkbox"/> .

3.6 Communication menu block

3.6.1 General

-  • A printer or a computer in the safe area must be connected via the ACM200 communication module, refer to the ICS4_6x Installation manual.
- For detailed information on interface protocols and commands refer to the SICS Reference manual.

The `Communication` menu block consists of the following subblocks:

- Overview Showing the installed interfaces.
- COM1 Parameter settings for the standard IS-RS232 interface COM1.
- COM2 Parameter settings for the optional second interface COM2.
- Define templates Defining templates to be assigned to the application-specific printouts.

The interfaces identify themselves. Therefore only those menu settings appear which are relevant for the individual interface. If no optional interface is installed, the COM2 menu will not appear.



3.6.2 Overview of the communication menu blocks

RS232 / CL20mA menu block

Level 1	Level 2	Level 3	Level 4
Mode	Print, Auto print, Instant print, Dialog , Continuous (Dialog), External input, Toledo Cont.-weight, Second display, SICS scale		
	Digitol B, Digitol G	Net Gross Tare	On, Off
Printer	Type	ASCII printer , Values only	
	ASCII Format	Line format	Multiple , Single, Fixed
		Line length	1 ... 24 ... 100
		Separator (for line format Single only)	, ; - _ / \ Space
Add line feed	0 ... 9		
External input	Preamble length		
	Data length		
	Postamble length		
	Termination character	CR, LF, EOT, ...	
	Destination	Off, Tare preset, ID1, ID2, ID3	
Parameter	Baud	300, 600, ... 9600 , ... 115200 baud	
	Parity	7 none, 8 none, 7 odd, 8 odd, 7 even, 8 even	
	Handshake	Off, Xon – Xoff	
	Checksum	Off, On	
Reset RS232	Perform Reset?		

-  The CL20mA interface is only available via a communication module in the safe area.

3.6.3 Description of the communication menu blocks

Mode	Operating mode of the serial interface
Print	Manual data output of stable results to the printer with 
Auto print	Automatic output of stable results to the printer (e.g., for series weighing operations)
Instant print	Manual data output of the current weight value (either stable or not) to the printer with 
Dialog	Bi-directional communication via MT-SICS commands, control of the device via PC
Continuous (Dialog)	Ongoing output of all weight values via the interface
External input	Input other than via terminal keypad. What the input is used for is defined in the <code>Destination</code> menu block.
Toledo Cont.-weight	TOLEDO Continuous mode
Second display	On the selected interface port, a second display is connected.
Digital scale	On the selected interface port, a digital scale is connected.
Digitol B	Digitol compatible format. The gross weight is identified by "B".
Digitol G	Digitol compatible format. The gross weight is identified by "G".
Net, Gross, Tare	Selecting the weight values to be transferred.
Notes	Printing conditions for <code>Auto print</code> : <ul style="list-style-type: none"> • The weight must be heavier than 9 display increments. • A weight change of at least 9 display increments is required to initiate the next printout.

Printer	Configuring printer and formats for the protocol printout	
Type	ASCII printer	If <code>Values only</code> is selected, the transmitted data does not include the name of the variable, e.g., date, gross, ID1, but the value and, if appropriate, the unit, as a separate line. This allows the label printer to fill its template with the required data.
	Values only	
ASCII format	Line format	Selecting line format (for ASCII printers only)
	Multiple	Multiple lines
	Single	Single lines
	Fixed	Fixed (records output in single lines; every record includes the number of characters that was defined under <code>Line length</code>)
	Line length	Setting line length This item is only displayed for the line formats <code>Multiple</code> and <code>Fixed</code> .
	Separator	Selecting the separator This item is only displayed for the line format <code>Single</code> .
	Add line feed	Adding line feeds

External input	Configuring input via barcode reader
Preamble length	The barcode may contain additional data before the relevant data (preamble) and behind (postamble). – Enter the number of characters of preamble, (relevant) data and postamble.
Data length	
Postamble length	
Termination char.	Selecting the termination character which is used by the connected barcode scanner
Destination	Selecting the item to be entered via barcode scanner

Parameter	Communication parameters
Baud	Selecting baud rate
Parity	Selecting parity
Handshake	Selecting handshake
Checksum	Activating/deactivating checksum byte
STX	Activating/deactivating STX If STX is set to <i>On</i> , the STX signal (0x02) is sent at the beginning of each output string that is sent via the interface.

3.6.4 Define templates menu block

Level 1	Level 2	Level 3
Template 1	Line 1	Not used, Header *, Date, Time, Gross, Net, Tare, High resolution, ID1, ID2, ID3, Terminal ID, Terminl loc., SNo. Terminal, SNo. Scale, Star line, New line, Form feed
...	...	
Template 5	Line 30	

* The content of these items has to be entered via SICS command.

Configuring templates

- 1 Select a template.
- 2 Select a line.
- 3 Assign an item.

i There are 5 more templates available (Template 6 ... Template 10). Please ask your **METTLER TOLEDO** service technician to configure these templates or create them by yourself using the DatabICS software (www.mt.com/ind-databics), if desired.

3.7 Maintenance menu block

3.7.1 Overview

Level 1	Level 2	Level 3	Level 4
Scale test	Scale	Internal test	Perform test?
		External test	Perform test?
		Conf. ext. test	Test weight
	Weight name		
	Auto print	On, Off	Tolerance
Keyboard test	Perform test?		
Display test	Perform test?		
Serial no.	Serial no. Scale		
	Serial no. Terminal terminal		
Print setup	Print menu settings		
Tool comm.	Port		
	Baudrate		
	Start		
Reset all	Perform reset?		

3.7.2 Description

Scale test	Testing the selected scale
Internal test	Testing scales with an internal test weight
Perform test?	<ul style="list-style-type: none"> – Press <input type="checkbox"/> OK to start the test. ⇒ The deviation between test weight value and actually weighed value is displayed.
External test	Testing scales without an internal test weight
Perform test?	<ol style="list-style-type: none"> 1 Press <input type="checkbox"/> OK to start the test. ⇒ Preload is displayed. 2 If applicable, load the preload, and press <input type="checkbox"/> OK. ⇒ The test weight is blinking. 3 Load the requested test weight and press <input type="checkbox"/> OK. ⇒ The deviation between test weight value and actually weighed value is displayed.
Conf. ext. test	Configuring the external test weight
Test weight	Setting the test weight value
Weight name	Entering the test weight name
Tolerance	Setting the test tolerance
Auto print	Automatic printout When set to On , a protocol is printed for each scale test.

Keyboard test	Testing the keyboard
Perform test?	<ol style="list-style-type: none"> 1 Press <input type="checkbox"/>OK✓ to start the keyboard test. 2 Press the keys in the displayed order. <ul style="list-style-type: none"> ⇒ If the key works, the device switches to the next key. ⇒ The keyboard test is terminated by pressing .

Display test	Testing the display
Perform test?	<ol style="list-style-type: none"> 1 Press <input type="checkbox"/>OK✓ to start the display test. <ul style="list-style-type: none"> ⇒ A checkerboard pattern is displayed. 2 Press any key to invert the checkerboard pattern. 3 Press any key again. <ul style="list-style-type: none"> ⇒ Completed is displayed. 4 Press <input type="checkbox"/>OK✓ to leave the display test.
Note	The display is working properly when all fields are displayed without missing pixels.

Serial number	Displaying serial numbers
SNo. Scale	Displaying the serial number of the connected weighing platform
SNo. Terminal	Displaying the serial number of the weighing terminal

Print setup	Printout of a list of all menu settings
Print menu settings	– Press <input type="checkbox"/> OK✓ to start the printout.

Tool communication	Testing the communication
Port	Selecting the COM port to be tested
Baudrate	Setting the baudrate for testing
Start	Starting tool communication test

Reset all	Reset all settings to factory setting
Perform reset?	– Reset all settings to factory settings with <input type="checkbox"/> OK✓.

4 Event and error messages

4.1 Error conditions

Error	Cause	Remedy
Display dark	• Backlighting set too dark	– Set backlighting brighter.
	• No power supply	– Check power supply.
	• Unit switched off	– Switch on unit.
	• Power supply cable not plugged in	– Plug in power supply cable.
	• Brief fault	– Switch device off and on again.
Weight display unstable	• Unstable installation location	– Adjust vibration adapter.
	• Draft	– Avoid draft.
	• Unstable weighing sample	– Dynamic weighing.
	• Contact between weighing pan and/or weighing sample and surrounding	– Remedy contact.
	• Power supply fault	– Check power supply
Incorrect weight display	• Incorrect zeroing	– Unload scale, set to zero and repeat weighing operation.
	• Incorrect tare value	– Clear tare.
	• Contact between weighing pan and/or weighing sample and surroundings	– Remedy contact.
	• Weighing platform tilted	– Level weighing platform.
[- - - -]	• Load plate not on the scale	– Place load plate on the scale.
	• Weighing range not reached	– Set to zero.
[- - - -]	• Weighing range exceeded	– Unload scale. – Reduce preload.
- - - - -	• Result not yet stable	– If necessary, adjust vibration adapter.
Attention: Approval invalid alternating with metrological data	• Approval was tampered with	– Call METTLER TOLEDO service technician.

4.2 Errors and warnings

Error messages

Error messages contain the following information:



- 1 Error message
- 2 Remedy
- 3 Message identifier
- 4 How to clear the message

Warnings

Warnings are displayed briefly and then disappear automatically.

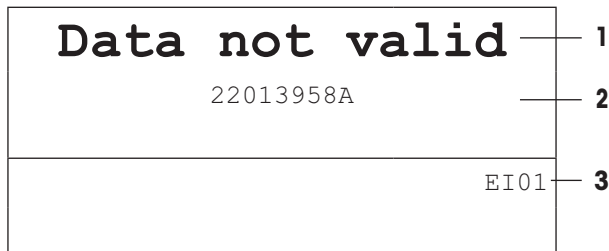

- 1 Warning
- 2 Additional information, e.g., which data is not valid
- 3 Warning identifier

4.3 Smart weighing counter / spanner icon

This weighing instrument features several control functions to monitor the condition of the device.

The **METTLER TOLEDO** service technician can setup and enable these functions.

This helps the user and the **METTLER TOLEDO** service technician to determine how the device is treated and what measures are needed to keep it in a good shape.

If the control functions triggers an alert, a message is shown.

You can confirm the message and continue to work with the weighing instrument. The spanner icon  lights up.

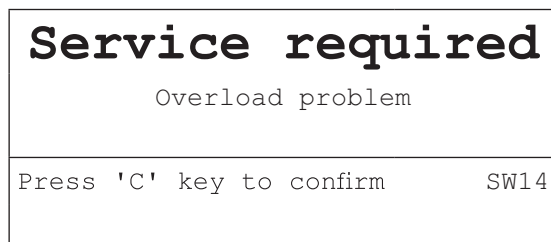

In case of an alert we strongly recommend calling the **METTLER TOLEDO** service technician

- to replace parts which are at the end of lifetime,
- to correct wrong settings,
- to educate operators about proper handling,
- to perform routine service work,
- to reset the alert.

The control functions monitor the following conditions:

- number of weighings
- number of overloads
- maximum weight
- zero commands and zero failures
- battery charging cycles
- power-on time
- date for the next service inspection

4.4 Service information

In case you need the **METTLER TOLEDO** service technician, you can read the necessary system and contact information from the device.

- 1 Press **i** twice.
⇒ System information data are displayed.
- 2 Press **i** again
⇒ Your contact data are displayed.

5 Technical data

Technical data		ICS426x
Housing		Stainless steel
Display		Monochrome LCD graphical display with backlighting
Keyboard		Tactile touch membrane keypad (PET), scratch-resistant labeling
Net weight		2.8 kg / 6.1 lb
Protection type		IP65
Mains connection		via APS768x
Ambient conditions	Application	indoor use only
	Temperature range Class III	-10 °C ... 40 °C / 14 °F ... 104 °F
	Humidity	Max. rel. humidity 85 %, for temperatures up to 40 °C / 104 °F
Ignition protection type	EN/IECEx	II 2G Ex ib IIC T4 Gb, -10 °C ... + 40 °C II 2D Ex ib IIC T60°C Db IP65
	cFM _{US}	IS Class I, II, III; Division 1 Group A, B, C, D, E, F, G; T4; Ta = 40 °C Aex ib IIC T4; IP65; Type 4
W & M approvals		OIML Class II, III, IIII NTEP Class II, III
Interfaces		1 interface RS232-IS and 1 digital scale interface integrated 1 additional optional communication interface
Applications		Straight weighing Average weighing Clever print

Dimensional drawing

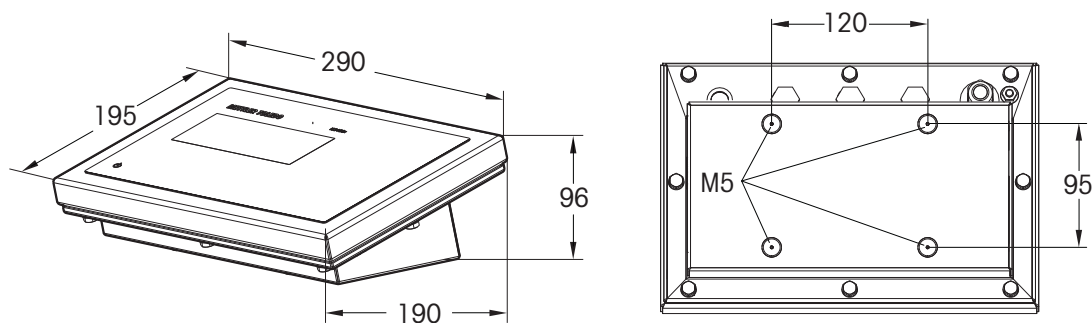

Weighing ranges and readability

i For weighing ranges and readability of the compact scales refer to the weighing platform documentation.

6 Appendix

6.1 Disposal

In accordance with the requirements of European Directive 2002/96 EC on Waste Electrical and Electronic Equipment (WEEE), this device may not be disposed of with domestic refuse. This also applies for countries outside the EU in accordance with their respective national regulations.



- Please dispose of this product in accordance with local regulations for the separate collection of waste electrical and electronic equipment.

Should you have any questions, please contact the corresponding authorities or the dealer from whom this device was purchased.

If this device is passed on (for example for further private or commercial/industrial use), this regulation is also to be passed on.

Many thanks for your contribution to the protection of the environment.

6.2 Protocol printouts

GA46 printouts, in English

Straight weighing

```

XXXXXXXXXXXXXXXXXXXXX
Gross          1.19 kg
Net            0.37 kg
Tare           0.82 kg
    
```

Average weighing

```

XXXXXXXXXXXXXXXXXXXXX
Gross          1.19 kg
NetAverage     0.37 kg
Tare           0.82 kg
    
```

Printout with header (standard printout)

```

METTLER TOLEDO
Tel. +49 7431 140
Germany
www.mt.com

Date          27/04/2015
Time          22:21:14
Net           0.37 kg
Tare          0.82 kg

Dev.Id        #4591-22.A
Dev.Loc       Building B9
    
```

Printout with header and identification data

```

METTLER TOLEDO
Tel. +49 7431 140
Germany
www.mt.com

Date          27/04/2015
Time          21:50:48
ID1           Company ABC
ID2           67195 Town
Net           0.57 kg
Tare          0.82 kg
Gross         1.39 kg
    
```

Index

A

Application	
Clever print	24
Average weighing	
Operation	14
Settings	24

C

Calibration	20
Cleaning	15
Clever print	13, 24
Connections	8

D

Dimensional drawing	37
Display	
3-line mode	5
Metrological data line	5
Serial numbers	33
Settings	27
Symbols and info line	6
Units	21
Weight value	6
Dynamic weighing	
Operation	14
Settings	24

E

Energy save	26
Error conditions	34
Error messages	35
External input	
Entry	14
Settings	31

F

FACT	
Settings	22
Symbol	6
Filter	22

G

Geo Code	
Display	10

I

Identifications	
Scale data	20
Terminal data	26
Weighing data	14
Info key	
Displaying information	13
Settings	27

K

Keyboard	
Function keys	7
Settings	27

L

Levelling	9
Linearization	20
Location	9

M

Maintenance	32
Menu	
Analog scale	19
Application	24
Communication	29
Display	17
Maintenance	32
Operation	16
Operator menu	16
Scale	19
Supervisor menu	16
Metrological data line	5
MinWeigh	
Settings	22
Symbol	6

P

Printing	13
Clever print	13
Printout configuration	24
Protocol printouts	38

R

Reset	
Application	24
Reset all	33
Scale	23
Terminal	28
Resolution	21
Restart	21

S

Safety instructions	3
Service information	36
Smart weighing counter	36
Spanner icon	4, 36
Straight weighing	10, 24
Supervisor menu access	28
Switching on/off	10
Switching units	10

T

Taring	
Automatic	11
Automatic clearing the tare	11
Chain tare	12
Clearing the tare	11
Manual	11
Settings	21
Tare preset	12
Technical data	37
Templates	
Assigning	24
Defining	31
Testing	
Communication	33
Display	33
Keyboard	33
Scale	32

V

Verification test	15
-------------------	----

W

Warning	35
---------	----

Z

Zeroing	
Automatic	11
Manual	11
Settings	21

To protect your product's future:
METTLER TOLEDO Service assures
the quality, measuring accuracy and
preservation of value of this product
for years to come.

Please request full details about our
attractive terms of service.

www.mt.com

For more information

Mettler-Toledo (Albstadt) GmbH

Unter dem Malesfelsen 34
D-72458 Albstadt, Germany
Tel. +49 7431-14 0
Fax +49 7431-14 232
www.mt.com

Subject to technical changes.
© Mettler-Toledo (Albstadt) GmbH 11/2016
30323194B en



30323194