

Pro-face

GP-2401/2501/2601 Series

User Manual
(Pro-Designer Compatible)

Preface

Thank you for purchasing the Pro-face GP-2401/2501/2601 Series programmable operator interface (hereafter referred to as the “GP unit”).

GP-2401/2501/2601 Series units allow you to use the CF Card without attaching separately sold expansion units.

Please read this manual carefully as it explains, step by step, how to use the GP correctly and safely.

Also, in this manual’s examples, the Mitsubishi MELSEC-AnA Series PLC is referred, whenever possible, as a point-to-point connection.

<Note>

- 1) It is forbidden to copy the contents of this manual, in whole or in part, except for the user’s personal use, without the express permission of Digital Electronics Corporation of Japan.
- 2) The information provided in this manual is subject to change without notice.
- 3) This manual has been written with care and attention to detail; however, should you find any errors or omissions, please contact Digital Electronics Corporation and inform them of your findings.
- 4) Please be aware that Digital Electronics Corporation shall not be held liable by the user for any damages, losses, or third party claims arising from any uses of this product.

All Company/Manufacturer names used in this manual are the registered trademarks of those companies.

© 2002 Digital Electronics Corporation

Table of Contents

Preface	1
Table of Contents	2
Essential Safety Precautions	4
General Safety Precautions	8
GP-2401/2501/2601 Series Model Names	10
Package Contents	10
UL/c-UL (CSA) Application Notes	11
CE Marking Notes	12
Revision Version	13
Documentation Conventions	13

CHAPTER 1 INTRODUCTION

1.1 System Design	1-1
1.1.1 GP-2401/2501/2601 Series System Design	1-1
1.2 Accessories	1-3

CHAPTER 2 SPECIFICATIONS

2.1 General Specifications	2-1
2.1.1 Electrical	2-1
2.1.2 Environmental	2-2
2.1.3 Structural	2-3
2.2 Functional Specifications	2-4
2.2.1 Display	2-4
2.2.2 Memory	2-4
2.2.3 Clock	2-5
2.2.4 Interfaces	2-5
2.3 Interface Specifications	2-6
2.3.1 Serial Interfaces (COM1)	2-6
2.4 Part Names and Functions	2-8
2.5 Dimensions	2-10
2.5.1 GP-2401T External Dimensions	2-10
2.5.2 GP-2501T External Dimensions	2-11
2.5.3 GP-2601T External Dimensions	2-12
2.5.4 Panel Cut Dimensions	2-13
2.5.5 Installation Fasteners	2-13

CHAPTER 3 INSTALLATION AND WIRING

3.1 Installation	3-1
3.1.1 Installation Procedures	3-1
3.2 Wiring Cautions	3-6
3.2.1 Connecting the Power Cord	3-6
3.2.2 Connecting the Power Supply	3-8
3.2.3 Grounding	3-9
3.2.4 I/O Signal Line Placement	3-9
3.3 Tool Connector	3-10
3.4 CF Card Installation and Removal	3-11
3.4.1 CF card Handling	3-13
3.5 Attaching the Screw Lock Terminal Block	3-14

CHAPTER 4 SETTINGS

4.1 Types of Settings	4-1
4.1.1 Offline	4-3
4.1.2 System	4-5

CHAPTER 5 TROUBLESHOOTING

5.1 Troubleshooting Checklists	5-1
5.1.1 No display	5-2
5.1.2 Connected devices cannot be used	5-2
5.2 SELF TEST	5-3
5.2.1 SELF TEST item list	5-3
5.2.2 SELF TEST - details	5-4

CHAPTER 6 MAINTENANCE

6.1 Regular Cleaning	6-1
6.1.1 Cleaning the Display	6-1
6.1.2 Installation Gasket Check/Replacement	6-1
6.2 Periodic Check Points	6-3
6.3 Replacing the Backlight	6-4

Essential Safety Precautions

This manual includes procedures that must be followed to operate the GP correctly and safely. Be sure to read this manual and any related materials thoroughly to understand the correct operation and functions of this unit.

Safety Icons

Throughout this manual the following icons are provided next to GP operation procedures requiring special attention, and provide essential safety information. These icons indicate the following levels of danger:



Indicates situations where severe bodily injury, death or major equipment damage can occur.



Indicates situations where slight bodily injury or machine damage can occur.

WARNINGS

System Design

- **Do not create GP touch panel switches that could possibly endanger the safety of equipment and personnel. Damage to the GP, its I/O unit(s), cable(s), and other related equipment can cause an output signal to remain continuously ON or OFF and possibly cause a major accident. Therefore, design all monitoring circuits using limit switches, etc. to detect incorrect device movement. To prevent accidents related to incorrect signal output or operation, design all switches used to control vital machine operations so they are operated via a separate control system.**
- **Please design your system so that equipment will not malfunction due to a communication fault between the GP and its host controller. This is to prevent any possibility of bodily injury or material damage.**
- **Do not use the GP unit as a warning device for critical alarms that can cause serious operator injury, machine damage or production stoppage. Critical alarm indicators and their control/activator units must be designed using stand-alone hardware and/or mechanical interlocks.**
- **The GP is not appropriate for use with aircraft control devices, aerospace equipment, central trunk data transmission (communication) devices, nuclear power control devices, or medical life support equipment, due to these devices' inherent requirements of extremely high levels of safety and reliability.**

 **WARNINGS**

- Do not create switches used to control machine safety operations, such as an emergency stop switch, or a GP touch screen icon. Be sure to install these switches as separate hardware switches, otherwise severe bodily injury or equipment damage can occur.
- When using the GP with : transportation vehicles (trains, cars and ships), disaster and crime prevention devices, various types of safety equipment, non-life support related medical devices, etc., redundant and/or failsafe system designs should be used to ensure the proper degree of reliability and safety.

Touch Panel

- After the GP's backlight burns out, the touch panel is still active. If the operator fails to notice that the backlight is burned out and touches the panel, a potentially dangerous malfunction can occur.

If your GP's backlight suddenly turns OFF, use the following steps to determine if the backlight is actually burned out.

- 1) When the backlight burnout feature is not set, and the screen has gone blank, your backlight is burned out.
- 2) When the backlight burnout feature is set, and the screen has gone blank, if touching the screen does not cause the backlight to turn ON, your backlight is burned out.

It is recommended to use the feature that disables the device operation to prevent accidental machine misoperation when a backlight burnout is detected automatically.

Wiring

- To prevent an electric shock, be sure to confirm that the GP's power cord is not connected to the main power when connecting any cords, cables or lines to the GP.
- Be sure to replace the GP's plastic terminal block cover after wiring is completed, since operating the GP without the cover may lead to an electric shock
- Do not use power beyond the GP's specified voltage range. Doing so may cause a fire or an electric shock.



WARNINGS

Battery Replacement

- The GP uses a lithium battery for backing up its internal clock data. If the battery is incorrectly replaced, the battery may explode. To prevent this, please do not replace the battery yourself. When the battery needs to be replaced, please contact your local GP distributor.

Installation/Maintenance

- High voltage runs through the GP. Except for replacing the backlight, never take apart the GP, otherwise an electrical shock can occur.
- Do not modify the GP unit. Doing so may cause a fire or an electric shock.
- Do not use the GP in an environment where flammable gasses are present, since operating the GP may cause an explosion.



CAUTIONS

Installation/Maintenance

- Be sure to securely connect all cable connectors to the GP. A loose connection may cause incorrect input or output.



CAUTIONS

Wiring

- Ground the GP's FG line separately from other units' FG lines. Putting these FG lines too close may cause an electric shock or unit malfunction. Be sure to use a grounding resistance of 100Ω or less and a 2mm^2 or thicker wire, or your country's applicable standard.
- Be sure the GP's rated voltage is within the designated range, and that the power terminal lines are correctly attached. If the voltage supplied differs from the rated voltage, or incorrect wiring or grounding is performed, it may cause a fire or unit malfunction.
- Use only the designated torque to tighten the GP's terminal block screws. If these screws are not tightened firmly, it may cause a short-circuit, fire, or GP malfunction.
- Be careful that metal filings and wiring debris do not fall inside the GP, since they can cause a fire, GP malfunction, or incorrect unit operation.

Display Device/CF Card

- The liquid crystal panel contains a powerful irritant and if for any reason the panel is damaged and this liquid contacts any part of your body, be sure to wash that area with running water for 15 minutes. If any of this liquid enters your eye, flush your eye for 15 minutes with running water and contact a physician.
- Prior to inserting or removing a CF Card, be sure the CF Card ACCESS lamp is not lit. If you do not, CF Card internal data may be damaged or lost.
- While a CF Card is being accessed, NEVER turn OFF or reset the GP, or insert or remove the CF Card. Prior to performing these operations, create and use a special GP application screen that will prevent access to the CF Card.

Unit Disposal

- When this unit is disposed of, it should be done so according to your country's regulations for similar types of industrial waste.

General Safety Precautions



- *Do not strike the touch panel with a hard or pointed object, or press on the touch panel with too much force, since it may damage the touch panel or the display.*
- *Do not install the GP where the ambient temperature can exceed the allowed range. Doing so may cause the GP to malfunction or shorten its operation life.*
- *Do not restrict or limit the GP's naturally occurring rear-face ventilation, or store or use the GP in an environment that is too hot.*
- *Do not use this unit in areas where large, sudden temperature changes can occur. These changes can cause condensation to form inside the unit., possibly causing the unit to malfunction.*
- *Do not allow water, liquids, metal or charged particles to enter inside the GP's case, since they can cause either a GP malfunction or an electrical shock.*
- *Do not use or store the GP in direct sunlight, or in excessively dusty or dirty environments.*
- *Do not store or use the unit where strong jolting or excessive vibration can occur.*
- *Do not store or use the GP where chemicals (such as organic solvents, etc.) and acids can evaporate, or where chemicals and acids are present in the air.*
 - Corrosive chemicals: Acids, alkalines, liquids containing salt*
 - Flammable chemicals: Organic Solvents*
- *Do not use paint thinner or organic solvents to clean the GP.*
- *Do not store or operate the LCD display in areas receiving direct sunlight, since the sun's UV rays may cause the LCD display's quality to deteriorate.*
- *Storing this unit in areas at a temperature lower than is recommended in this manual's specifications may cause the LCD display's liquid to congeal, which may damage the panel. Conversely, if the storage area's temperature becomes higher than the allowed level, the LCD's liquid will become isotropic, causing irreversible damage to the LCD. Therefore, be sure to store the panel only in areas where temperatures are within those specified in this manual.*
- *Do not connect or disconnect the communication cable between the GP and the host during power-ups.*
- *Due to the possibility of unexpected accidents, be sure to back up the GP's screen data regularly.*



■ About the GP's Display Panel

- *The GP's currently displayed data, its voltage^{*1} and brightness setting each affect the intensity of Contouring. (i.e, when some parts of the screen are brighter than others, creating a wavelike pattern)*
- *There are minute grid-points (dark and light) on the Display Panel's surface. This is part of the GP's design and not a defect.*
- *Extended shadows, or "Crosstalk" may appear on the sides of screen images. This is normal for an LCD display.*
- *Sometimes the display area may look as if the display colors have changed. This is a common attribute of LCD's and is not a defect.*
- *Displaying a single image for long periods can cause an afterimage to remain when the display is changed to another screen.*

To prevent this effect:

- *Do not display any single screen for a long period of time. Try to periodically change the screen display.*

**1 If the GP's voltage is at the very low end of its allowable range, it may effect the intensity of contouring.*

GP-2401/2501/2601 Series Model Names

The GP-2401/2501/2601 Series refers to the following GP model numbers:

Series	Model Name	Model Type	Comments	
GP2000 Series	GP-2401 Series	GP-2401T	GP2401-TC41-24V	UL/c-UL (CSA) Approved, CE Marked
	GP-2501 Series	GP-2501T	GP2501-TC11	*1
		GP-2501S	GP2501-SC11	
GP-2601 Series	GP-2601T	GP2601-TC11	*1	

*1 Revised models may or may not be listed as products conforming to UL/c-UL (CSA) and CE Markings, depending on the revision version.

Reference For information on how to determine the revision version, refer to section “Revision Version” (page 13).

Package Contents

The GP’s packing box contains the items listed below. Please check to confirm that all items shown below have been included.

■ **GP Unit (1)**

GP2401-TC41-24V
 GP2501-TC11
 GP2501-SC11
 GP2601-TC11

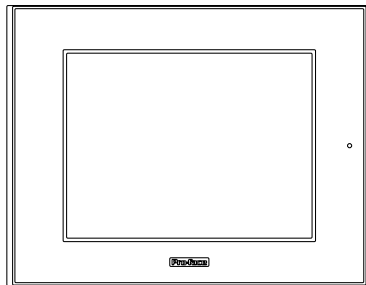

■ **Installation Gasket (1)**



■ **Installation Guide (1)**

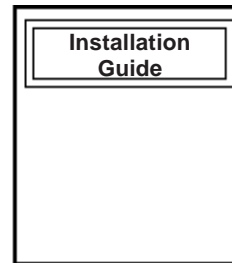

■ **Installation Fasteners (4/set) *1**

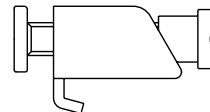

This unit has been carefully packed, with special attention to quality. However, should you find anything damaged or missing, please contact your local GP distributor immediately for prompt service.

*1 The shape of the supplied installation fastener may vary depending on the product model.

Reference 2.5.5 Installation Fasteners

However, the mounting method is the same for every fastener.

UL/c-UL (CSA) Application Notes

The GP2401-TC41-24V is UL/c-UL (CSA) listed products. (UL file No.E182139)
The GP2501-TC11*¹, GP2501-SC11*¹, GP2601-TC11*¹, are UL/c-UL (CSA) listed products. (UL file No.E231702)

This unit conforms as a product to the following standards:

Model	UL registered format	Standards					
		A	B	C	D	E	F
GP2401-TC41-24V	3180034-01	○		○	○		
GP2501-TC11* ¹	3180021-03		○	○		○	○
GP2501-SC11* ¹	3180021-04		○	○		○	○
GP2601-TC11* ¹	3180021-05		○	○		○	○

*1 The products on which Revision “3” is marked conform to the standard requirements.

Reference For more information on how to determine the revision version, refer to section “Revision Version” (page 13).

- A) **UL508** Industrial Control Equipment
- B) **UL60950** Safety Standard for Information Technology Equipment (3rd Edition, issued December 1, 2001)
- C) **UL1604** Electrical Equipment for use in Class 1 & 2 - Division 2, or Class 3 Hazardous Locations.
- D) **CAN/CSA-C22.2, Nos. 142, and 213-M1987** Safety Standard for Information Technology and Electrical Business Equipment
- E) **CAN/CSA-C22.2, No. 60950-00** Safety Standard for Information Technology Equipment (3rd Edition, issued December 1, 2001)
- F) **CAN/CSA-C22.2, No. 213-M1987** Safety Standard for Information Technology and Electrical Business Equipment

<Cautions>

- The GP must be used as a built-in component of an end-use product.
- The GP units must be used indoors only.
- This unit should be installed in the front face of a metal panel.
- If this unit is installed so as to cool itself naturally, be sure to install it in a vertical panel. Also, be sure that the GP unit is mounted at least 100 mm away from any adjacent structures or equipment. If these requirements are not met, the heat generated by the GP unit’s internal components may cause the unit to fail to meet UL/c-UL standard requirements.
- Make sure to set up a switch to turn off the power to the GP in an accessible position on the end-use product that the GP unit is built-in. Make sure to consider the current and voltage when selecting the switch.
- Make sure that the frame of the product to which the GP unit is built-in conforms to UL60950 standard requirements.

UL1604 Conditions of Acceptability and Handling Cautions:

1. Power, input and output (I/O) wiring must be in accordance with Class I, Division 2 wiring methods - Article 501- 4(b) of the National Electrical Code, NFPA 70 within the United States, and in accordance with Section 18-152 of the Canadian Electrical Code for units installed within Canada.
2. Suitable for use in Class I, Division 2, Groups A, B, C and D, Hazardous Locations.
3. **WARNING:** Explosion hazard - substitution of components may impair suitability for Class I, Division 2.
4. **WARNING:** Explosion hazard - when in hazardous locations, turn power OFF before replacing or wiring modules.
5. **WARNING:** Explosion hazard - do not disconnect equipment unless power has been switched OFF, or the area is known to be non-hazardous.

CE Marking Notes

The GP2401-TC41-24V is CE marked products that conform to EMC directives EN55011 Class A and EN61000-6-2.

The GP2501-TC11*¹, GP2501-SC11*¹ and GP2601-TC11*¹ are CE marked products that conform to EMC directives and the Low-voltage directive EN55011 Class A, EN61000-3-2, EN61000-3-3, EN61000-6-2 and EN60950.

For detailed CE marking information, please contact your local GP distributor.

**1 The products on which Revision "3" is marked conform to the standard requirements.*

Reference  For more information on how to determine the revision version, refer to section "Revision Version" (page 13).

<Cautions>

- The GP must be used as a built-in component of an end-use product.
- The GP units must be used indoors only.
- This unit should be installed in the front face of a metal panel.
- If this unit is installed so as to cool itself naturally, be sure to install it in a vertical panel. Also, be sure that the GP unit is mounted at least 100 mm away from any adjacent structures or equipment. If these requirements are not met, the heat generated by the GP unit's internal components may cause the unit to fail to meet the standard requirements.
- Make sure to set up a switch to turn off the power to the GP in an accessible position on the end-use product that the GP unit is built-in. Make sure to consider the current and voltage when selecting the switch.
- Make sure that the frame of the product to which the GP unit is built-in conforms to EN60950 standard requirements.

Revision Version

The revision version can be determined by the identification label or revision stickers that are placed on the main unit of the GP. The characters and numerals in the “REV” area that are replaced with asterisks (*), or marked with a marker indicate the revision version.

In the example below, the asterisks “*” are placed at positions “D”, “1”, and “2”, which indicates the revision version as “D, 1, 2”.

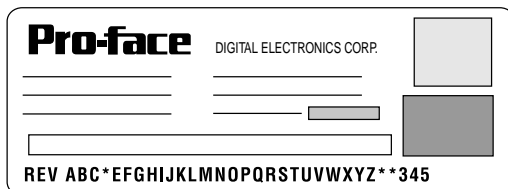

Identification Label



Revision Sticker

Documentation Conventions

The list below describes the documentation conventions used in this manual.

Symbol	Description
	Indicates important information or procedures that must be followed for correct and risk-free software/device operation.
*1	Indicates useful or important supplemental information.
1) , 2)	Indicates steps in a procedure. Be sure to perform these steps in the order given.
	Refers to useful or important supplemental information.
	Provides useful or important supplemental information.
Screen Editor	Indicates the Pro-Designer (version 4.0 or higher).
PLC	Abbreviation for Programmable Logic Controller.
n:1	Indicates a multi-link type connection is used.

Memo

Chapter 1 Introduction

- 1. System Design
- 2. Accessories

1.1 System Design

The following diagram represents the standard items connected to the GP.

1.1.1 GP-2401/2501/2601 Series System Design

■ GP RUN Mode Peripherals

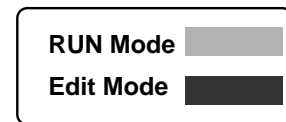

GP Unit

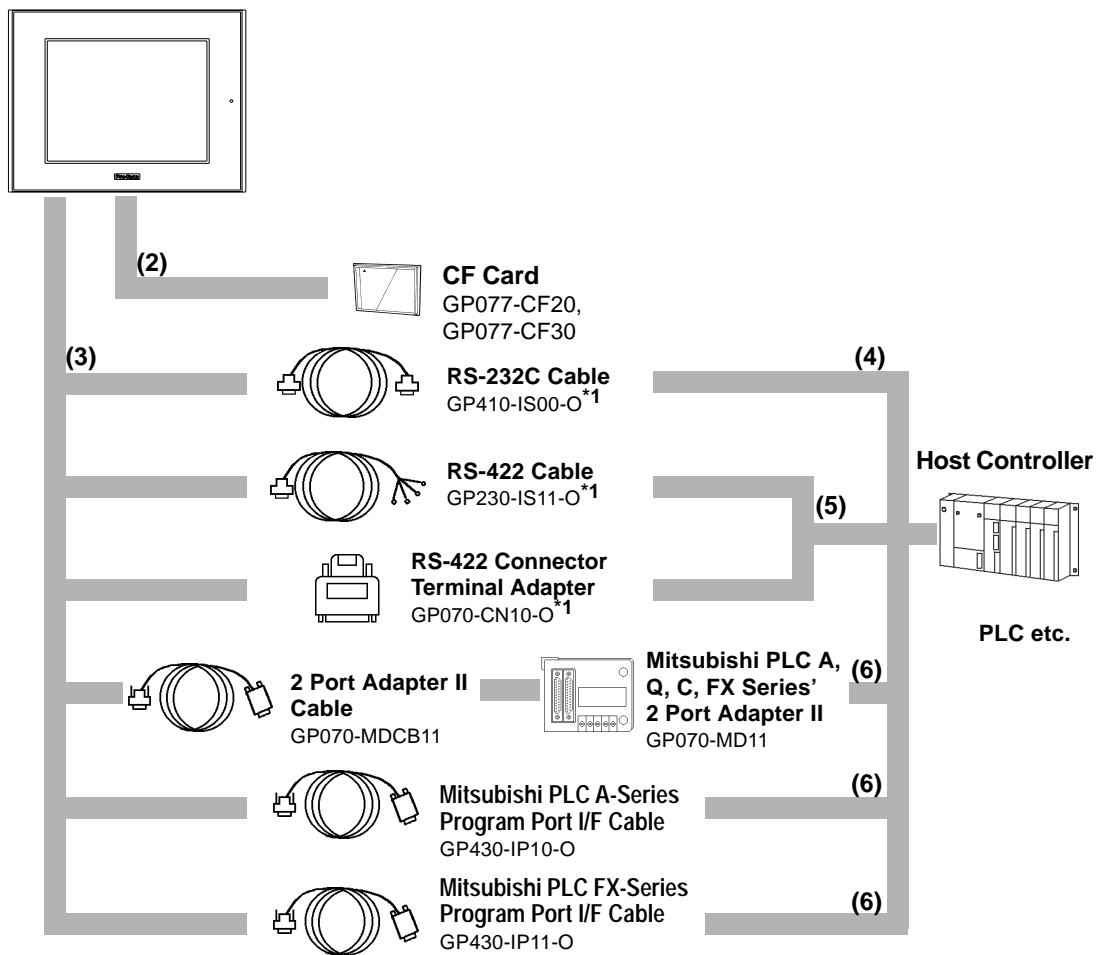

*1 Certain types and models of PLCs cannot be connected.

Reference Pro-Designer On-line Help

Chapter 1 - Introduction

■ GP Edit Mode Peripherals

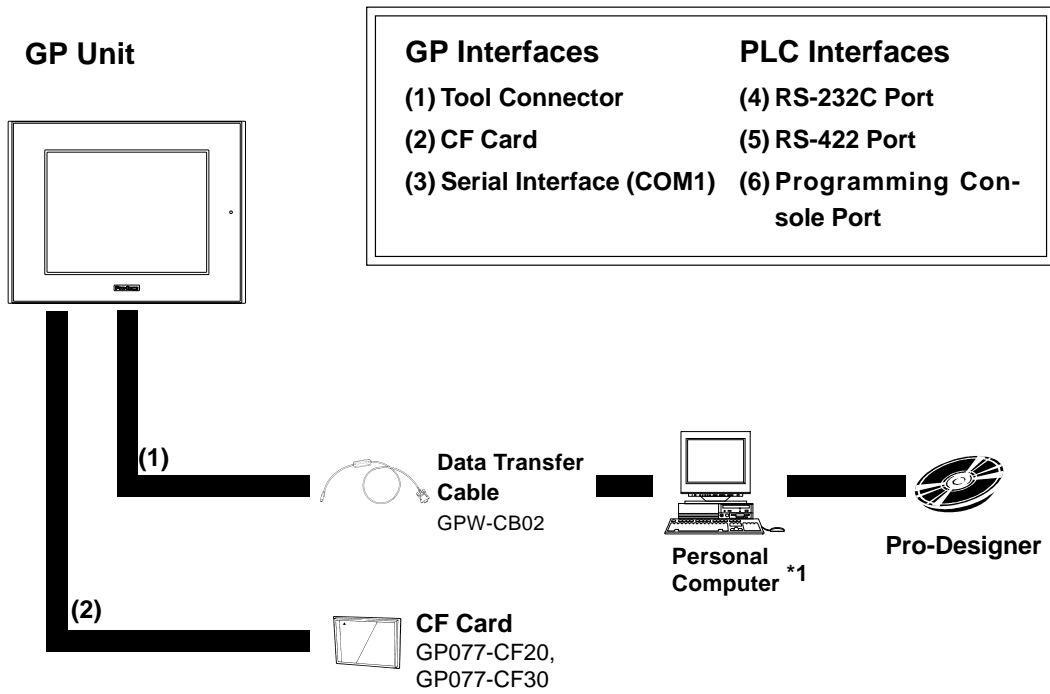

**1 Certain types and models of PCs cannot be connected.*

▼ Reference ▲ Pro-Designer On-line Help

1.2 Accessories

All optional equipment listed here is produced by Digital Electronics Corporation.

■ Available Software

Product Name	Model No.	Description
Pro-Designer Ver. 4.0 or later	PS-DWE01-V40	Software to be used to create the screen data. Installed in a personal computer.

■ Tool Connector

Product Name	Model No.	Description
Screen Data Transfer Cable	GPW-CB02	Connects the GP to a personal computer. Transfers screen data and user program(s).

■ Serial Interfaces

Product Name	Model No.	Description
RS-232C cable* ¹	GP410-IS00-O	Interface cables between the host (PLC) and the GP.
RS-422C cables* ¹	GP230-IS11-O	
RS-422 Connector Terminal Adapter* ¹	GP070-CN10-O	Conversion adapter to convert serial data to RS-422 format
2 Port Adapter II	GP070-MD11	Interface unit that allows use of both GP and Mitsubishi A, Q, C and FX series peripheral equipment.
2 Port Adapter II Cable	GP070-MDCB11	Connects the GP to 2 Port Adapter II.
Mitsubishi A Series Programming Port I/F cable	GP430-IP10-O	Connects directly to Mitsubishi's PLC Programming port. Simultaneous use of programming console, however, is not possible.
Mitsubishi FX Series Programming Port I/F cable	GP430-IP11-O	

*1 For detailed information about the range of connectable PLC manufacturers and models,

▼ **Reference** ▲ *Pro-Designer On-line Help*

Chapter 1 - Introduction

■ CF Card Items

Product Name	Model No.	Description
CF Cards	GP077-CF20	GP Series CF Card (16MB)
	GP077-CF30	GP Series CF Card (32MB)
CF Card Adaptor	GP077-CFAD10	CF Card Adapter for the PCMCIA Slot.

■ Screen Protection

Product Name	Model No.	Description
Screen Protection Sheet	PSL-DF00 (GP-2501T, GP-2501S, GP-2601T)	Disposable, dirt-resistant sheet for the GP's screen. The GP's touch panel can be operated with this cover sheet attached. (5 sheets/set)
	PS400-DF00 (GP-2401T)	

■ Maintenance Items

They are available separately as optional maintenance items.

Product Name	Model No.	Description
Backlight	PS400-BU00-MS (GP-2401T)	Replacement Backlight
	GP577RT-BL00-MS (GP-2501T)	
	PS501S-BU00 (GP-2501S)	
	PS600-BU00 (GP-2601T)	
Installation Fastener	GP070-AT01	Fasteners to attach the GP to a panel. (4 fasteners/set)
Installation Gasket	PS400-WP00-MS (GP-2401T)	Provides a moisture resistant seal when installing the GP. Same as the seal included in the GP's original equipment package.
	GP570-WP10-MS (GP-2501T/2501S/2601T)	
Connector Cover	PS-BH00	Attaches to GP rear face connectors. (3/set)

Chapter

2 Specifications

1. General Specifications
2. Functional Specifications
3. Interface Specifications
4. Part Names and Functions
5. Dimensions

2.1 General Specifications

2.1.1 Electrical

■ GP2501-TC11/GP2501-SC11/GP2601-TC11

Input Voltage	AC 100V	AC 100V to AC240V ^{*1}
Rated Voltage	AC85V to AC132V	AC85V to AC265V ^{*1}
Power Consumption	50VA or less	50VA or less (ACIN100V) ^{*1} 85VA or less (ACIN240V) ^{*1}
Allowable Voltage Drop	20ms or less	
Voltage Endurance	AC1500V 20mA for 1 minute (between charging and FG terminals)	
Insulation Resistance	10M Ω or higher at DC500V (between charging and FG terminals)	

**1 The products on which Revision "3" is marked conform to the standard requirements.*

Reference For more information on how to determine the revision version, refer to section "Revision Version" (page 13).

■ GP2401-TC41-24V

Input Voltage	DC 24V
Rated Voltage	DC19.2V to DC28.8V
Power Consumption	28W or less
Allowable Voltage Drop	10ms or less
In-rush Current	30A or less
Voltage Endurance	AC1000V 20mA for 1 minute (between charging and FG terminals)
Insulation Resistance	10M Ω or higher at DC500V (between charging and FG terminals)

Chapter 2 - Specifications

2.1.2 Environmental

	GP-2401T	GP-2501T	GP-2501S	GP-2601T
Ambient Operating Temperature	0°C to +50°C ¹			
Storage Temperature	-20°C to +60°C			
Ambient Humidity	10%RH to 90%RH (Non condensing, wet bulb temperature: 39°C or less)			
Atmospheric Endurance (GP Operation Altitude)	800hPa to 1114hPa (2000 meters or lower)			
Dust	0.1mg/m ³ or less (non-conductive levels)			
Atmosphere	Free of corrosive gasses			
Vibration Resistance	IEC61131-2 compliant			
	When vibration is NOT continuous 10Hz to 57Hz 0.075mm, 57Hz to 150Hz 9.8m/s ²			
	When vibration is continuous 10Hz to 57Hz 0.035mm, 57Hz to 150Hz 4.9m/s ² X, Y, Z directions for 10 times (80min.)			
Noise Immunity (via noise simulator)	Noise Voltage: 1000Vp-p	Noise Voltage: 1500Vp-p Pulse Duration: 1μs Rise Time: 1ns		
	Pulse Duration: 1μs Rise Time: 1ns			
Electrostatic Discharge Immunity	6kV (complies with IEC 61000-4-2 Level 3)			
Atmosphere	Free of corrosive gasses			

**1 When using GP-2601T in an environment where the temperature becomes or exceeds 40°C for an extended period of time, the screen contrast level may decrease from its original level of brightness.*

2.1.3 Structural

	GP-2401T	GP-2501T	GP-2501S	GP-2601T
Grounding	100Ω or less, or your country's applicable standard			
Ratings ^{*1} (For front panel of installed unit)	Equivalent to IP65f (JEM 1030) NEMA#250 Type4X/12			
Weight	1.7 kg (5.5lb) or less	3.5kg (7.7lb) or less		
Cooling Method	Natural air circulation			
External Dimensions	W215mm [8.46in] x H170mm [6.69in] x D60mm [2.36in]			W317mm [12.48in] x H243mm [9.57in] x D58mm [2.28in]

**1 The front face of the GP unit, installed in a solid panel, has been tested using conditions equivalent to the standards shown in the specification. Even though the GP unit's level of resistance is equivalent to these standards, oils that should have no effect on the GP can possibly harm the unit. This can occur in areas where either vaporized oils are present, or where low viscosity cutting oils are allowed to adhere to the unit for long periods of time. If the GP's front face protection sheet becomes peeled off, these conditions can lead to the ingress of oil into the GP and separate protection measures are suggested. Also, if non-approved oils are present, it may cause deformation or corrosion of the front panel's plastic cover. Therefore, prior to installing the GP be sure to confirm the type of conditions that will be present in the GP's operating environment. If the installation gasket is used for a long period of time, or if the unit and its gasket are removed from the panel, the original level of the protection cannot be guaranteed. To maintain the original protection level, you need to replace the installation gasket regularly.*

2.2 Functional Specifications

2.2.1 Display

	GP-2401T	GP-2501T	GP-2501S	GP-2601T
Type	TFT type color LCD		STN type color LCD	TFT type color LCD
Resolution	640 x 480pixels			800 x 600pixels
Effective Display Area	W149.8mm [5.90in.] x H112.3mm [4.42in.]	W211.2mm [8.34in.] x H158.4mm [6.24in.]		W246mm [9.69in.] x H184.5mm [7.26in.]
Colors	256 / No blink ^{*1} , 64 colors / 3-speed blink		64 colors / 3-speed blink	256 / No blink ^{*1} , 64 colors / 3-speed blink
Backlight	CCFL (Service life: 50,000 hrs. at 25°C and 24hr. operation)			
Brightness Control	4 levels of adjustment available via touch panel.			
Contrast Adjustment			8 levels of adjustment available via touch panel	
Language Fonts	ASCII: (Code page 850) Alphanumeric (incl. Eur. characters) Chinese: (GB2321-80 codes) simplified Chinese fonts Japanese: ANK 158, Kanji : 6962 (JIS Standards 1 & 2) Korean: (KSC5601 - 1992 codes) Hangul fonts Taiwanese: (Big 5 codes) traditional Chinese fonts			
Text Sizes	8X8, 8X16, 16X16 and 32X32 dot fonts			
Font Sizes	Both hight and width can be expanded 1, 2, 4 or 8 times.			
Text	8x8 dots	80 Char. x 60 rows		100 Char. x 75 rows
	8x16 dots	80 Char. x 30 rows		100 Char. x 37 rows
	16x16 dots	40 Char. x 30 rows		50 Char. x 37 rows
	32x32 dots	20 Char. x 15 rows		25 Char. x 18 rows

**1 Changing the “Colors” setting to “256 colors” will disable the blink feature on all of your project’s screens. If you wish to use the blink feature, do not change this setting to “256 colors”.*

2.2.2 Memory

	GP-2401T/GP-2501T/GP-2501S	GP-2601T
Application	6MB FLASH EPROM ^{*1}	8MB FLASH EPROM ^{*1}
Data Backup	128KB SRAM [uses a lithium battery] ^{*2}	

**1 Pro-Designer and GP-PRO/PBIII (C-Package02) each use application memory differently.*

**2 A Lithium battery’s lifetime is:*

10 years when the battery’s ambient temperature is 40 °C or less.

4.1 years when the battery’s ambient temperature is 50 °C or less.

1.5 years when the battery’s ambient temperature is 60 °C or less.

When used for backup:

Approximately 60 days, with a fully charged battery

Approximately 6 days, with a half-charged battery

2.2.3 Clock

	GP-2401T	GP-2501T	GP-2501S	GP-2601T
Resolution	32 x 24 keys/screen 1 or 2 point push - selectable			40 x 30 keys /screen 1 or 2 point push-selectable
Clock Accuracy	+ 65 seconds/month (at room temperature)			



Note: The GP's internal clock has a slight error. At normal operating temperatures and conditions, with the GP operating from its lithium battery, the degree of error is 65 seconds per month. Variations in operating conditions and battery life can cause this error to vary from -380 to +90 seconds per month. For systems where this degree of error will be a problem, the user should be sure to monitor this error and make adjustments when required.

2.2.4 Interfaces

Serial Interface (COM1)	Asynchronous Transmission : RS232C/RS422, Data Length: 7 or 8 bits, Stop Bit: 1 or 2 bits, Parity: None, Odd or Even, Data Transmission Speed: 2400 to 115.2kbps
Tool Connector	Asynchronous TTL level nonprocedural command I/F Used for transferring data to and from the Screen Editor and the GP.
CF Card Interface	1 slot
Printer Interface	Not available (Pro-Designer does not support this interface.)
AUX Input/Output	

2.3 Interface Specifications

2.3.1 Serial Interfaces (COM1)

This interface can be either RS-232C or RS-422. Connects GP to Host (PLC).

This interface uses a socket-type connector.

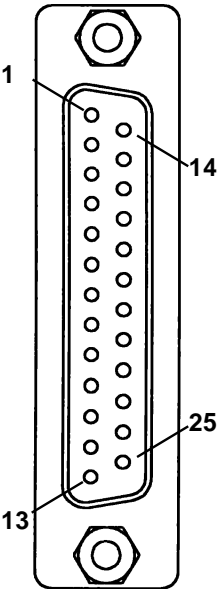
Pin Assignments	Pin #	Signal Name	Condition
(D-Sub 25pin female) SIO 	1	FG	Frame ground
	2	SD	Send data (RS-232C)
	3	RD	Receive data (RS-232C)
	4	RS	Request send (RS-232C)
	5	CS	Clear send (RS-232C)
	6	DR	Data Set Ready (RS-232C)
	7	SG	Signal ground
	8	CD	Carrier detect (RS-232C)
	9	TRMX	Termination (RS-422)
	10	RDA	Receive data A (RS-422)
	11	SDA	Send data A (RS-422)
	12	NC	No connection (Reserved)
	13	NC	No connection (Reserved)
	14	VCC	5V±5% output 0.25A
	15	SDB	Send data B (RS-422)
	16	RDB	Receive data B (RS-422)
	17	RI	Ring Indicate (RS-232C)
	18	CSB	Clear send B (RS-422)
	19	ERB	Enable receive B (RS-422)
	20	ER	Enable receive (RS-232C)
	21	CSA	Clear send A (RS-422)
	22	ERA	Enable receive A (RS-422)
	23	NC	No connection (Reserved)
	24	NC	No connection (Reserved)
	25	NC	No connection (Reserved)

Recommended Connector: Dsub25pin plug XM2A-2501<made by OMRON>

Recommended Cover: Dsub25pin cover XM2S-2511<made by OMRON>

Jack Screws: XM2Z-0071<made by OMRON>



- Use rough metric type M2.6x0.45 threads used to secure the cable's set screws.
Recommended Cable: CO-MA-VV-SB5P x 28AWG <made by HITACHI Cable Ltd.>
- To confirm your PLC's connection specifications, refer to **Reference Pro-Designer On-line Help**



When creating your own cable, follow the instructions listed below:

<With RS-422>

- The following pairs of pin numbers must be connected to each other.
 - #18 (CSB) <—> #19 (ERB)
 - #21 (CSA) <—> #22 (ERA)
- When connecting the RS-422 cable and the #9 (TRMX) and #10 (RDA) points, a termination resistance of 100Ω is added between RDA and RDB.
- When making a cable for a Memory Link system, be sure to use a 4-wire type.

<With RS-232C>

- Do not use the following pins: 9 (TRMX), 10 (RDA), 11 (SDA), 15 (SDB), 16 (RDB), 18 (CSB), 19 (ERB), 21 (CSA), 22 (ERA).
- The #1 (FG) terminal should only be connected if it is required by the device being connected to.



- *This unit's serial port is not isolated, therefore, it is important that you connect the SG (Signal Ground) terminals. If this is not done, the RS422 circuit may be damaged.*
- *Pin 14 (VCC) DC5V output is not protected. To prevent damage or unit malfunction, be sure to use only the designated level of current.*

2.4 Part Names and Functions

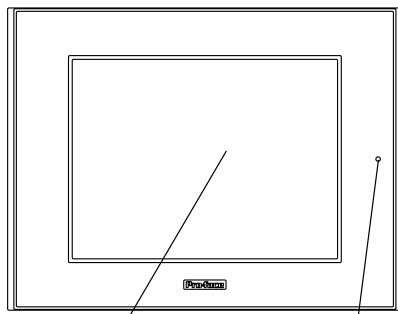

A,B C

Front

A: Display Panel

The GP monitor screen displays the screen setup and corresponding host (PLC) data.

GP-2401T	TFT type color LCD
GP-2501T	TFT type color LCD
GP-2501S	STN type color LCD
GP-2601T	TFT type color LCD

B: Touch Panel

Performs any screen change operations and sends data to the PLC.

C: Status LED

This LED reflects the GP's condition.

Color	Indicates
OFF	No power input
Green	Normal operation
Orange	Backlight is burned out

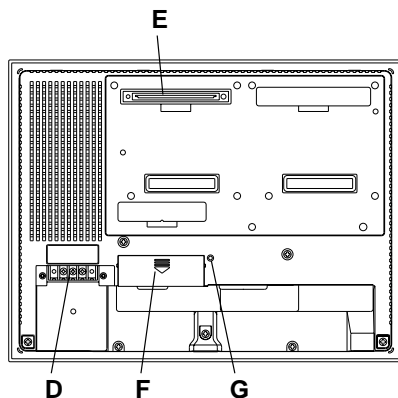

D F G

Rear

(GP-2501T/GP-2501S/GP-2601T)

D: Power Input Terminal Block

Connects the power cord.

E: Expansion Unit Interface (EXT1)

Not available (Pro-Designer does not support this interface.)

F: CF Card Cover

Open this cover to the CF Card Slot. When accessing the CF Card, this cover must be closed.

Note: The GP cannot access the CF Card if the CF Card cover is already opened.

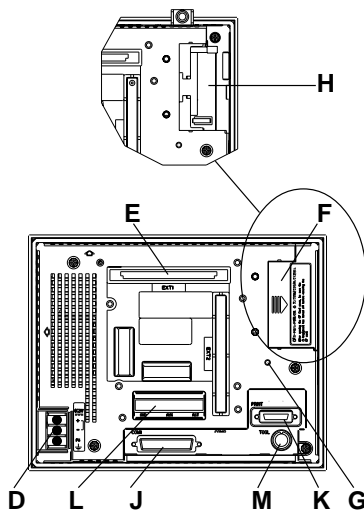

D L J M K G

Rear

(GP-2401T)

G: CF Card Access Lamp

If the CF Card Cover is closed when the CF Card is inserted, the LED lamp turns ON. The LED lamp will remain turned ON even if the CF Card Cover is opened while the GP accesses the CF Card.

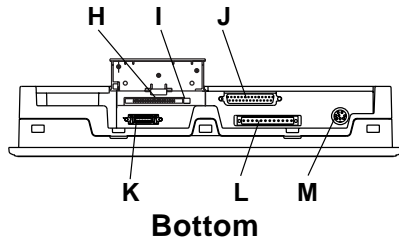

H: CF Card Slot

Insert a CF Card in this slot.

I : Dip Switches

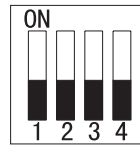

Dip Switch	Function	ON	OFF	Note
1	This Dip switch setting controls the startup from a CF Card.	Startup from CF Card is enabled.	Startup from CF Card is disabled.	CF Card with startup data required.
2	Reserved	—	—	Keep these switches OFF
3	Reserved	—	—	
4	This setting controls the forced closing of the CF Card cover.	Forced close enabled.	Forced close disabled.	Used when CF Card cover is damaged.

J : Serial Interface (COM1)

Connect the RS-232C and RS-422 cables here. Connect the other end to the Host (PLC.)

K :Printer Interface (PRINT)

Not available (Pro-Designer does not support this interface.)

L: Auxiliary Input/Output Interface (AUX Reset)

Not available (Pro-Designer does not support this interface.)

M:Tool Connector (TOOL)

The Data Transfer cable can be connected here.

2.5 Dimensions

2.5.1 GP-2401T External Dimensions

Unit: mm [in.]

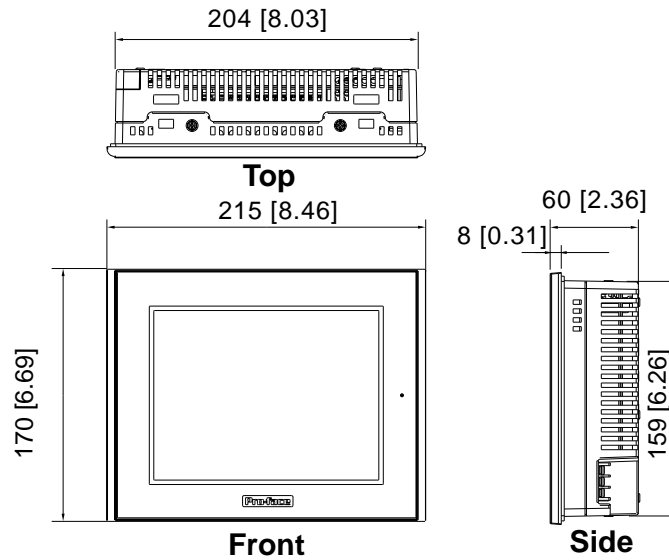

The following drawing shows the GP-2401T Series unit with installation fasteners.

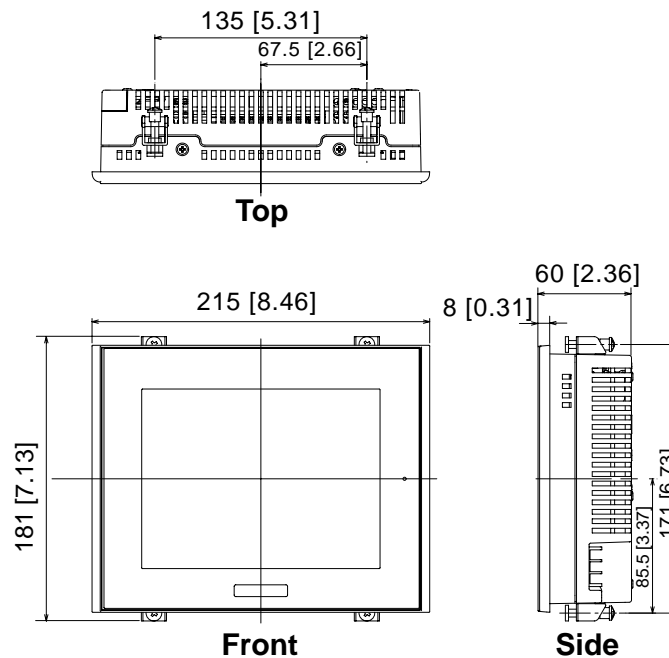

2.5.2 GP-2501T External Dimensions

Unit: mm [in.]

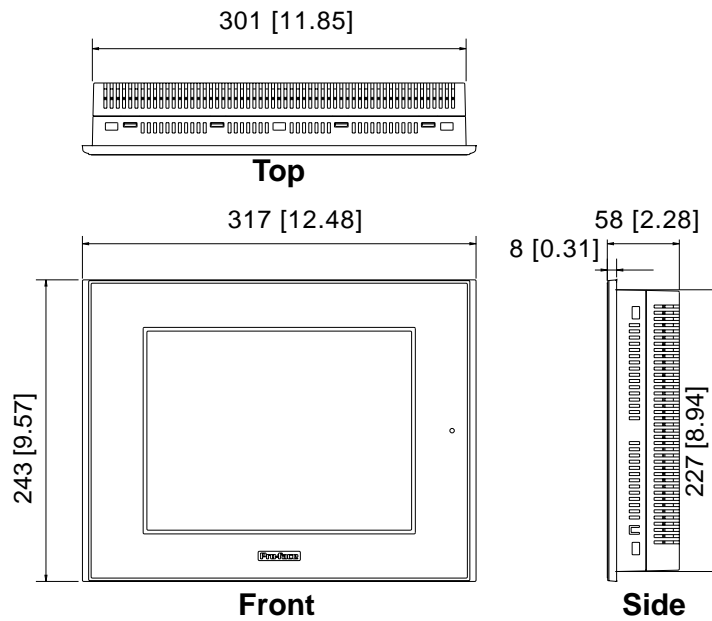

The following drawing shows the GP-2501T/2501S Series unit with installation fasteners.

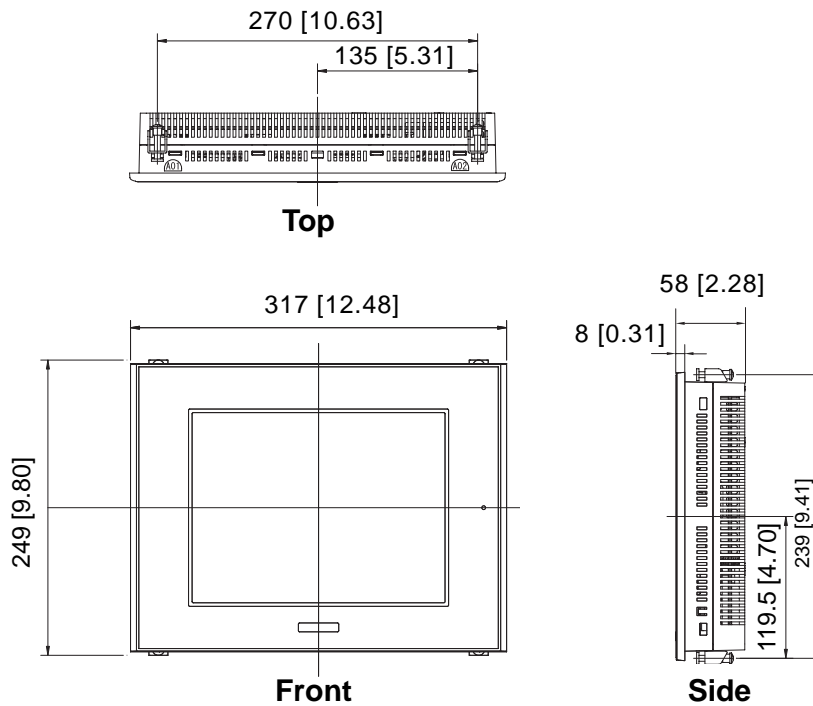

Chapter 2 - Specifications

2.5.3 GP-2601T External Dimensions

Unit: mm [in.]

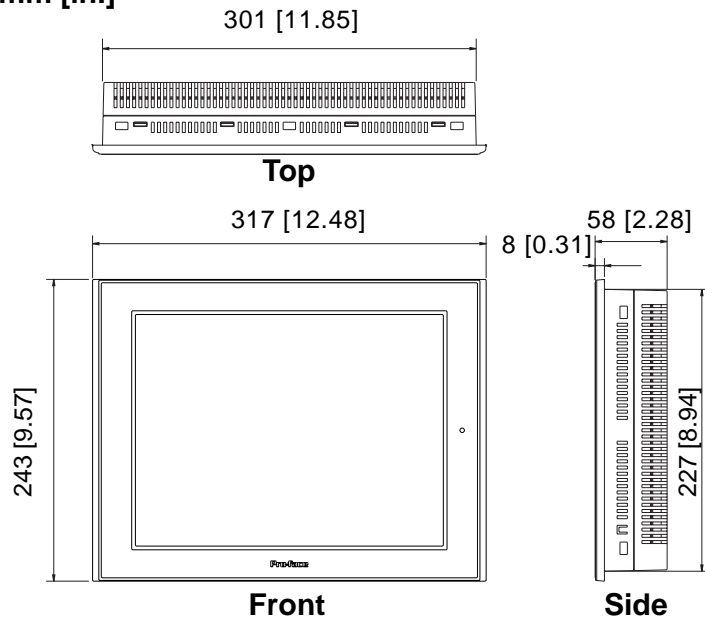

The following drawing shows the GP-2601T Series unit with installation fasteners.

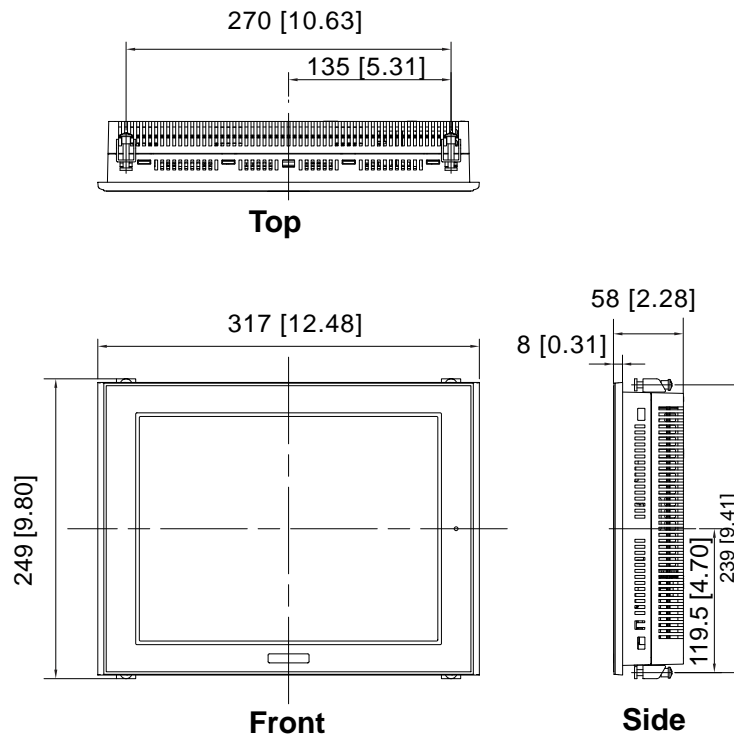

2.5.4 Panel Cut Dimensions

■ GP-2401T

Unit: mm [in.]

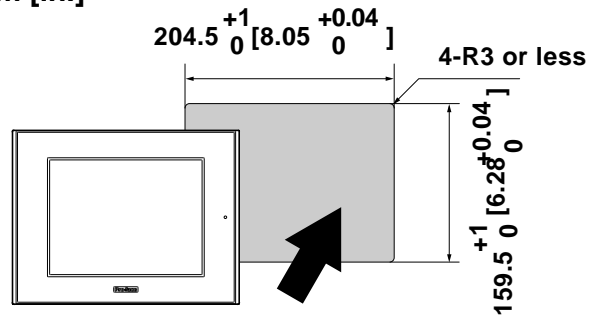

■ GP-2501T/2501S/2601T

Unit: mm [in.]

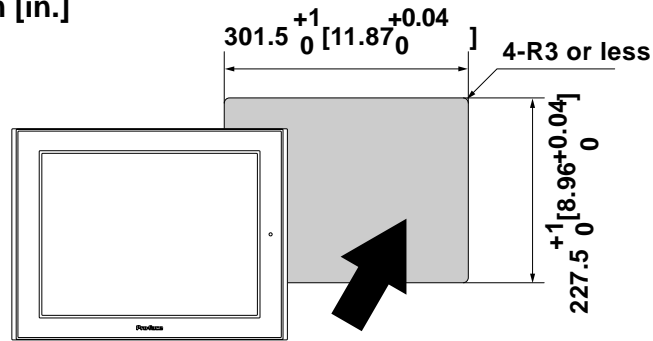

2.5.5 Installation Fasteners

Unit: mm [in.]

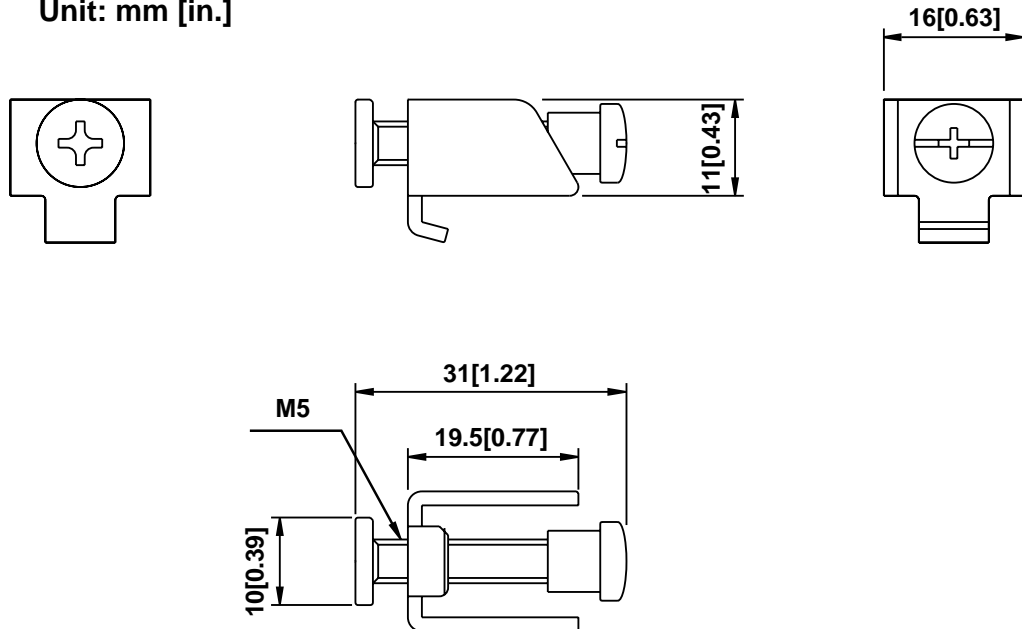

Memo

Chapter

3 Installation and Wiring

1. Installation
2. Wiring Cautions
3. Tool Connector
4. CF Card Installation and Removal
5. Attaching the Screw Lock Terminal Block

3.1 Installation

3.1.1 Installation Procedures

Follow the steps given below when installing the GP.

■ Check the Installation Gasket's Seating

It is strongly recommended that you use the installation gasket, since it absorbs vibration in addition to repelling water.

Place the GP on a level surface with the display panel facing downward. Check that the GP's installation gasket is seated securely into the gasket's groove, which runs around the perimeter of the panel's frame.

For details about installing the gasket, refer to

▼ **Reference** 6.1.2 *Installation Gasket Check/Replacement*



- **Before installing the GP into a cabinet or panel, check that the installation gasket is securely attached to the unit.**
- **A gasket which has been used for a long period of time may have scratches or dirt on it, and could have lost much of its dust and drip resistance. Be sure to change the gasket periodically, or when scratches or dirt become visible.**
- **Be sure to use gasket model PS400-WP00-MS (GP-2401T)/GP570-WP10-MS (GP-2501T/2501S/2601T).**
- **Be sure the gasket's seam is not inserted into any of the unit's corners, only in the straight sections of the groove. Inserting it into a corner may lead to its eventually tearing.**

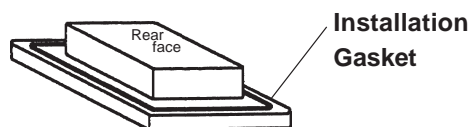

Chapter 3 - Installation and Wiring

■ Creating a Panel Cut

Create the correct sized opening required to install the GP, using the installation dimensions given.

▼ **Reference** ▲ 2.5.4 GP Panel Cut Dimensions

The installation gasket, installation brackets and attachment screws are all required when installing the GP.

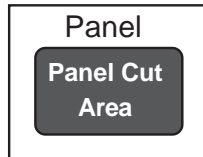

Note: Check that the installation panel or cabinet's surface is flat, in good condition and has no jagged edges. Also, if desired, metal reinforcing strips can be attached to the inside of the panel, near the Panel Cut, to increase the panel's strength.



Panel thickness should be from 1.6mm [0.06in.] to 10mm [0.4in.]. Decide the panel's thickness based on the level of panel strength required.

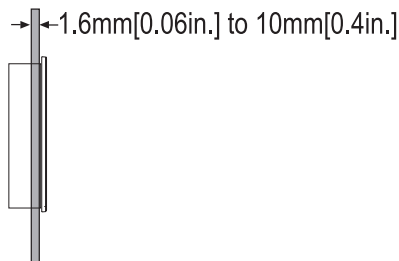

For easier maintenance, operation, and improved ventilation, be sure to install the GP at least 100 mm [3.94 in.] away from adjacent structures and other equipment.

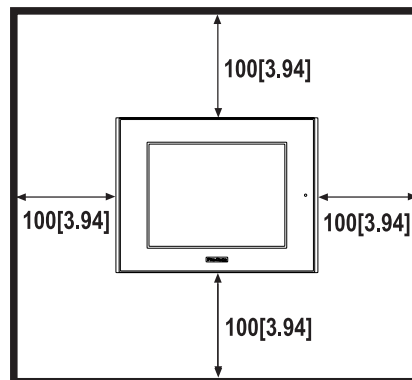
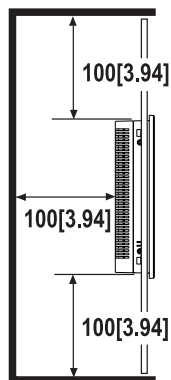

Chapter 3 - Installation and Wiring



- **Be sure that the ambient operation temperature and the ambient humidity are within their designated ranges. (When installing the GP in a cabinet or enclosure, the term “ambient operation temperature” indicates the cabinet or enclosure’s internal temperature.**

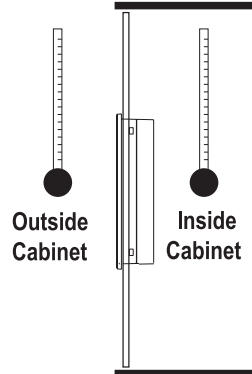

- **Be sure that heat from surrounding equipment does not cause the GP to exceed its standard operating temperature.**
- **When installing the GP in a slanted panel, the panel face should not incline more than 30°.**

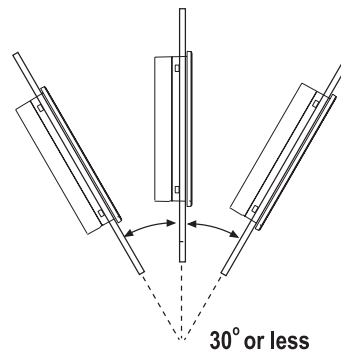

- **When installing the GP in a slanted panel, and the panel face inclines more than 30°, the ambient temperature must not exceed 40 °C. You may need to use forced air cooling (fan, A/C) to ensure the ambient operating temperature is 40 °C or below.**
- **When installing the GP vertically, position the unit so that the Power Input Terminal Block is also vertical.**

Chapter 3 - Installation and Wiring

■ Installing the GP

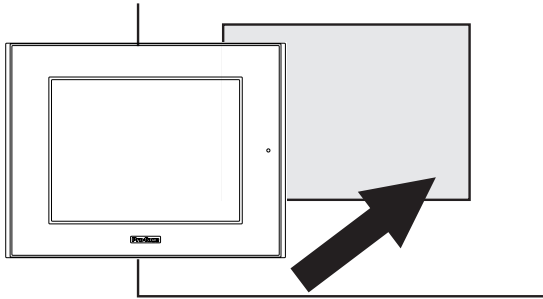

- 1) Insert the GP into the panel cut out, as shown here.

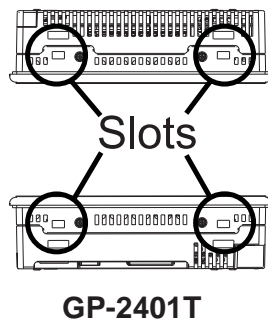

- 2) Insert the installation fasteners into the GP's insertion slots, at the top and bottom of the unit.
(total: 4 slots)



Do not use the attachment holes in the middle of side panels.

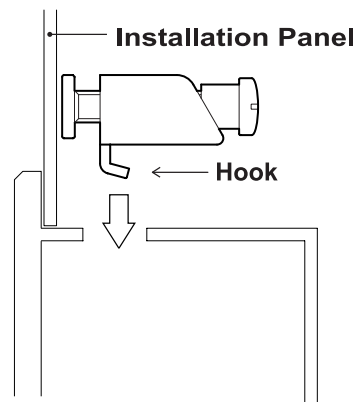
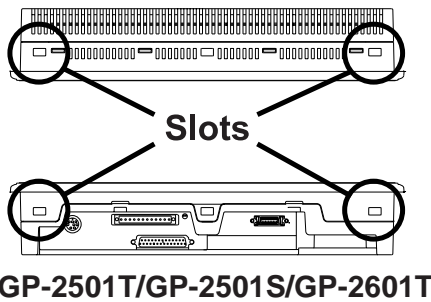

Chapter 3 - Installation and Wiring

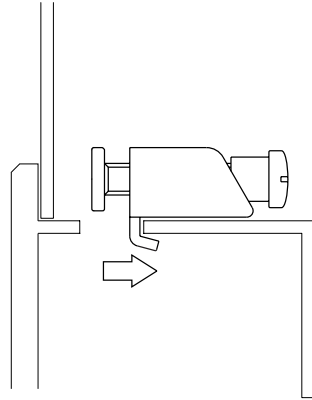

- 3) Insert each of the fasteners shown below. Be sure to pull the fastener back until it is flush with the rear of the attachment hole.

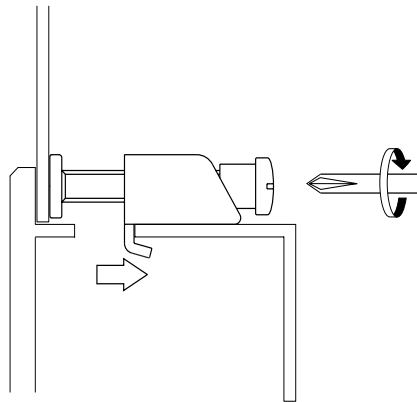

- 4) Use a Phillips screwdriver to tighten each fastener screw and secure the GP in place.



A torque of only 0.5 N•m is sufficient to tighten these screws. Do not use too much force, since it may damage the GP unit.



Note: Depending on the panel condition, you can improve moisture resistant effect by increasing the number of installation fasteners. However, since GP-2401T has only four installation holes, you cannot increase it in this case.

3.2 Wiring Cautions

3.2.1 Connecting the Power Cord



WARNINGS

- To avoid an electric shock, be sure the power cord is unplugged from the power outlet when connecting the power terminals to the GP unit.
- GP2401-TC41-24V is designed to use only with 24 VDC power. Using any other level of power can damage both the power supply and the GP unit.
- For models GP2501-TC11, GP2501-SC11 and GP2600-TC11, products on which REV “3” is not marked are designed to use only with 100 VAC power. Using any other level of power can damage both the power supply and the GP unit.
- Since the GP is not equipped with the power switch, be sure to connect a breaker type power switch to the GP’s power cord.
- Be sure to ground the GP’s FG terminal. Failure to do so can lead to an electrical shock or GP malfunction.



- *When the FG terminal is connected, be sure the wire is grounded. Not grounding the GP unit will result in excessive noise. Use your country’s applicable standard for grounding.*
- *To prevent the Ring Terminals from causing a short when the terminal block attachment screws are loosened, be sure to use sleeve-type Ring Terminals.*

Reference 3.2.3 Grounding

- *The SG and FG terminals are connected internally in the GP unit.*
- *When connecting the SG line to another device, be sure that the design of the system/connection does not produce a shorting loop.*



- Wherever possible, use thick wires (max 2mm²) for power terminals, and twist the exposed wire ends when connecting the Ring Terminals.
- Please use the following size crimp-on type Ring Terminals.

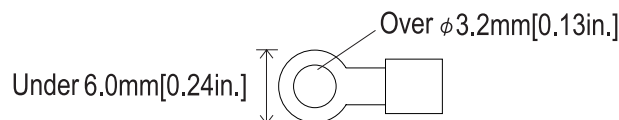

- *To prevent the Ring Terminals from causing a short when the terminal block attachment screws are loosened, be sure to use sleeve-type Ring Terminals.*

■ Connecting the Power Supply Terminals

◆ GP2501-TC11, GP2501-SC11, GP2601-TC11

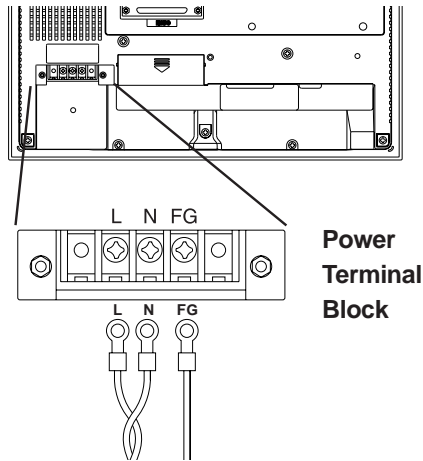

L	AC Input Live Line
N	AC Input Neutral Line
FG	Grounding Terminal connected to the GP chassis.

◆ GP2401-TC41-24V

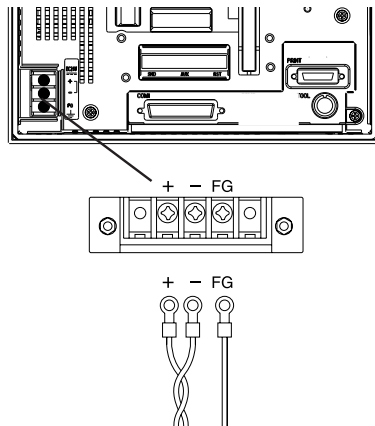

+	Positive electrode
-	Negative electrode
FG	Grounding Terminal connected to the GP chassis.

- 1) Be sure that the GP's power cord is not plugged in to the power supply.
- 2) Remove the Terminal Strip's clear plastic cover.
- 3) Remove the screws from the three (3) middle terminals, position the Ring Terminals as shown above and reattach the screws. (Check each wire to make sure the connections are correct)
- 4) Reattach the Terminal Strip's clear plastic cover.



A torque of only 0.5 to 0.6 N•m is required to tighten an attachment screw.

3.2.2 Connecting the Power Supply

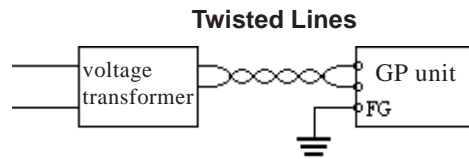

- If the supplied voltage exceeds the GP unit's range, connect a voltage transformer.

Reference Chapter 2 Specifications for the allowable voltage range.

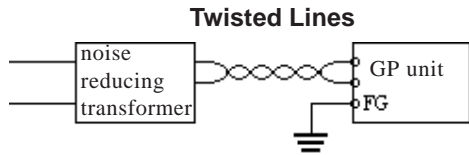

- For between the line and ground, select a power supply that is low in noise. If there is an excess amount of noise, connect a noise reducing transformer.

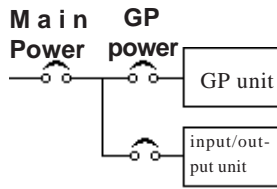

Use Voltage and Noise Reducing transformers with capacities exceeding 100VA.

- When supplying power to the GP unit, please separate the input/output and operation unit lines, as shown.

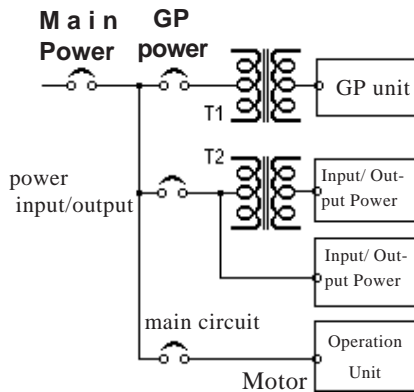

- To increase the noise resistance quality of the power cable, simply twist each power wire before attaching the Ring Terminal.
- The power supply cable must not be bundled or positioned close to main circuit lines (high voltage, high current), or input/output signal lines.

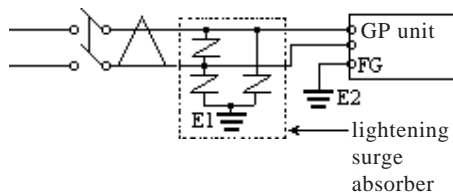

- Connect a lightning surge absorber, as shown in the diagram, to deal with power surges.
- To avoid excess noise, make the power cable as short as possible.



Be sure to ground the surge absorber (E1) separately from the GP unit (E2).

- **Select a surge absorber that has a maximum circuit voltage greater than that of the peak voltage of the power supply.**

3.2.3 Grounding



CAUTION

Do not use common grounding, since it can lead to an accident or machine breakdown.

(a) Exclusive Grounding (BEST) *1

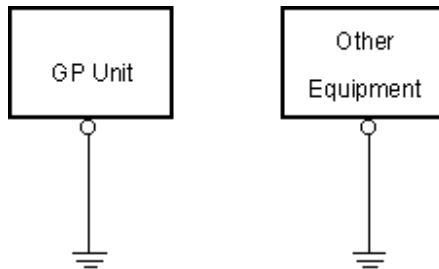

Connect the FG terminal found at the back of the GP to an exclusive ground. [diagram (a)].

- **Check that the grounding resistance is less than 100Ω.**
- **The SG and FG terminals are connected internally in the GP unit.**
- **When connecting the SG line to another device, be sure that the design of the system/connection does not produce a shorting loop.**
- **The grounding wire should have a cross sectional area greater than 2mm². Create the connection point as close to the GP unit as possible, and make the wire as short, as possible. When using a long grounding wire, replace the thin wire with a thicker wire, and place it in a duct.**

(b) Common Grounding (OK)*1

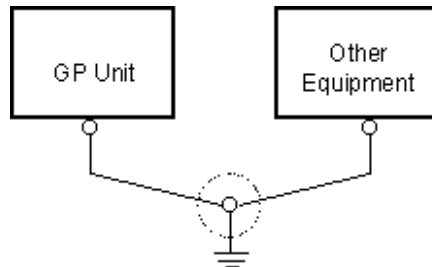

(c) Common Grounding (Not OK)

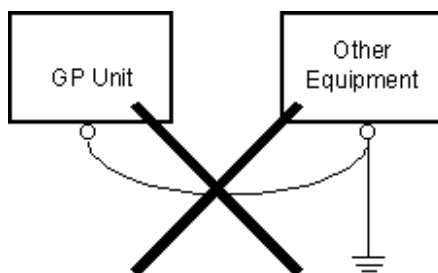

If exclusive grounding is not possible, use a common connection point. [diagram (b)]



Note: If the equipment does not function properly when grounded, disconnect the ground wire from the FG terminal.

3.2.4 I/O Signal Line Placement

- Input and output signal lines must be separated from the power control cables for operating circuits.
- If this is not possible, use a shielded cable and connect the shield to the GP's frame.

*1 Use a grounding resistance of less than 100W and a 2mm² or greater thickness wire, or your country's applicable standard. For details, contact your local GP distributor.

3.3 Tool Connector

The GP's Data Transfer Cable can be attached to the GP unit's Tool Connector.



WARNING

To prevent an electric shock, unplug the GP unit's power cord from the main power supply prior to attaching or detaching any connector(s) to or from the GP.

Bottom Face
GP-2501T/GP-2501S/ GP-2601T

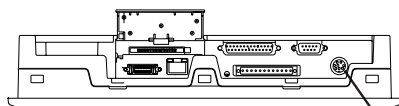

Rear Face
GP-2401T

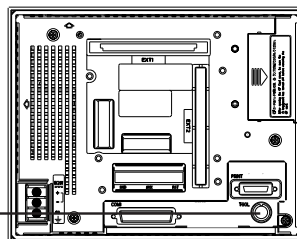

Tool Connector

3.4 CF Card Installation and Removal



CAUTIONS

When using the GP Unit and a CF Card, follow the precautions below:

- Prior to inserting or removing a CF Card, be sure to turn the GP unit's CF Card ACCESS switch OFF and to confirm that the ACCESS lamp is not lit. If you do not, CF Card internal data may be damaged or lost.
- While a CF Card is being accessed, NEVER turn OFF or reset the GP, or insert or remove the CF Card. Prior to performing these operations, create and use a special GP application screen that will prevent access to the CF Card.

Reference *Pro-Designer On-line Help*

- Prior to inserting a CF Card, familiarize yourself with the CF Card's front and rear face orientation, as well as the CF Card connector's position. If the CF Card is not correctly positioned when it is inserted into the Mulit Unit, the CF Card's internal data and the GP unit may be damaged or broken.
- Be sure to use only CF Cards manufactured by the Digital Electronics Corporation. GP unit performance cannot be guaranteed when using another manufacturer's CF Card.
- Once GP data is lost, it cannot be recovered. Since accidental data loss can occur at any time, be sure to back up all GP screen and CF Card data regularly.
- Be sure to follow the instructions given below to prevent the CF Card's internal data from being destroyed or a CF Card malfunction from occurring:
 - DO NOT bend the CF Card.
 - DO NOT drop or strike the CF Card against another object.
 - Keep the CF Card dry.
 - DO NOT touch the CF Card connectors.
 - DO NOT disassemble or modify the CF Card.

Chapter 3 - Installation and Wiring

■ Inserting the CF Card

Use the following steps to insert the CF Card in the GP.

(The illustrations below show the procedures for the GP-2501T/GP-2501S/GP-2601T models. However, these procedures are also the same for the GP-2401T.)

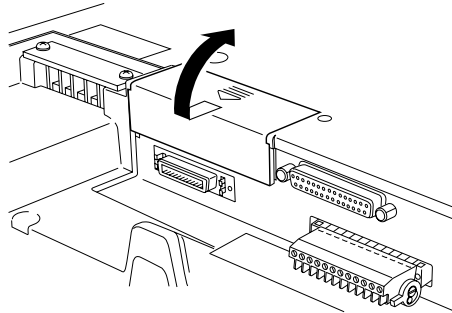

- 1) Slide the CF Card Cover in the direction shown here, then upwards to open the cover.

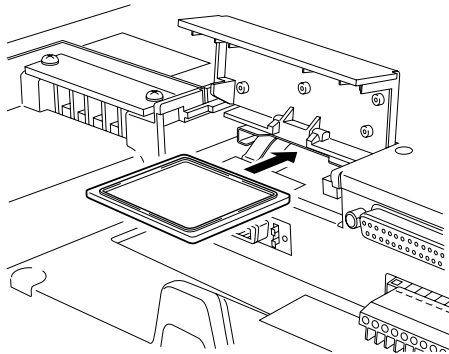

- 2) Insert the CF Card in the CF Card Slot, until the ejector button is pushed forward.

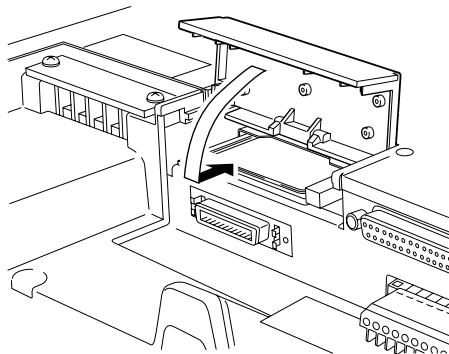

- 3) Close the cover. (As shown.)
- 4) Confirm that the CF Card Access LED turns ON.



Note: The GP cannot access the CF Card if the CF Card cover is already opened. If however, the CF Card Cover is opened while the GP is accessing the CF Card, access will not be interrupted.

■ Removing the CF Card

Simply reverse the steps shown in the previous “Inserting CF Card” explanation. Prior to removing the CF Card, confirm that the CF Card Access LED is turned OFF.

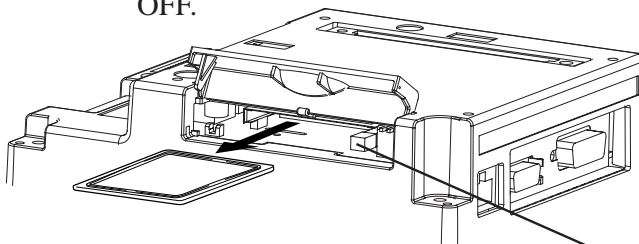

Eject Button

3.4.1 CF card Handling

The CF Card has a data overwrite limit of approximately 100,000 times. Therefore, be sure to back up all CF Card data regularly to another storage media.

(100,000 times assumes the overwriting of 500KB of data in DOS format)

Two methods are available for backing up data. After using either method 1) or method 2), use your PC to save your data to the CF Card.

(1) If your PC is equipped with a PC Card Slot

To view CF Card data on a personal computer, first, insert the CF Card into a CF Card Adapter.

(2) If your PC is NOT equipped with a PC Card slot

Use a commercially available PC Card Reader, or a CF Card Reader.

<Recommended CF Card Reader>

Manufacture Name	Model	Connection Type
I-O DATA DEVICE, INC.	CardDock-CF/P	Parallel port



- Depending on the setup of your PC, it is possible that the Card Reader may not operate correctly.
- All of Pro-face's CF Card operation testing has been performed using the following equipment. The connection between a personal computer and the CF Card reader has been tested using a Windows® compatible machine. This does not mean, however, that all Windows® compatible machines can be used. Please contact your PC or CF Card reader manufacturer directly for details.

3.5 Attaching the Screw Lock Terminal Block

Using the AUX Input/Output I/F requires the separately sold Screw Lock Terminal Block. Use the procedures shown below to attach the Screw Lock Terminal Block to your GP unit's AUX I/O I/F.

(The illustrations below show the procedures for the GP-2501T/GP-2501S/GP-2601T models. However, these procedures are also the same for the GP-2401T.)

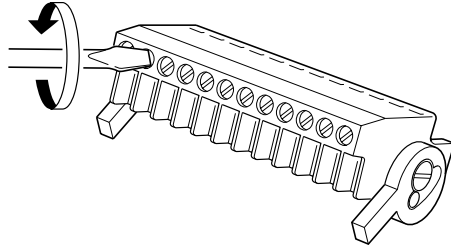

- 1) Loosen the set screws of each desired Screw Lock Terminal Block pin.

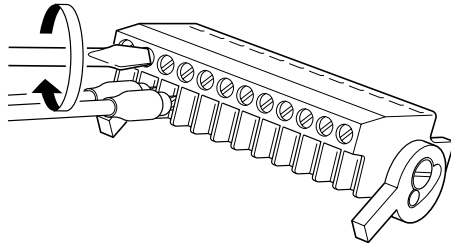

- 2) Insert each wire end into its pin and tighten the set screw.

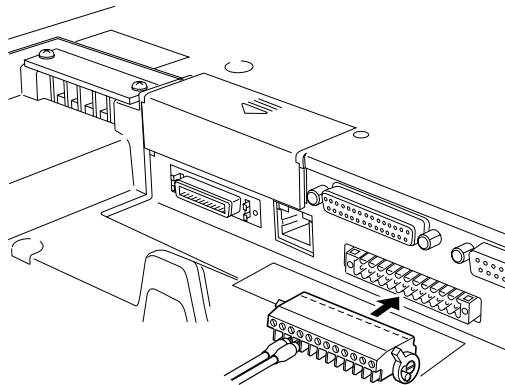

- 3) Re-insert the Terminal Block into the AUX I/O I/F.

- 4) Raise both of the Terminal Block's right and left side clamp levers to secure the Terminal Block to the AUX I/O I/F.

Chapter 4 Settings

1. Types of Settings

4.1 Types of Settings

The settings required for the GP unit, when starting Runtime or when in RUN mode, are found in the Settings Menu.

To call up this menu:

1. Connect the GP unit's power supply.



Note: Pro-Designer Runtime must be installed. For installation instructions, refer to Pro-Designer Ver. 4.0 or later software's On-line Help.

2. After the GP starts up, touch the upper left corner of the screen within 10 seconds to call up the menu. You can also enter Setting mode at any time by simultaneously touching the upper right corner, bottom right corner, and bottom left corner of the screen. Pro-Designer Runtime will restart and the [Settings Menu] will appear.
3. In this mode, the two tabs, [Offline] and [System] are available. Simply touch the desired tab to bring up those settings.

The following screen shows the [Offline] area's selections.

Chapter 4 - Settings

■ Offline

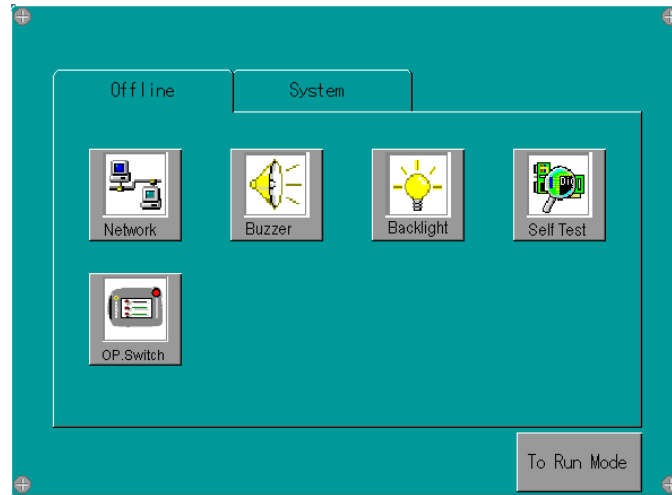

- Network
- Buzzer
- Backlight
- Self Test
- OP. Switch

■ System

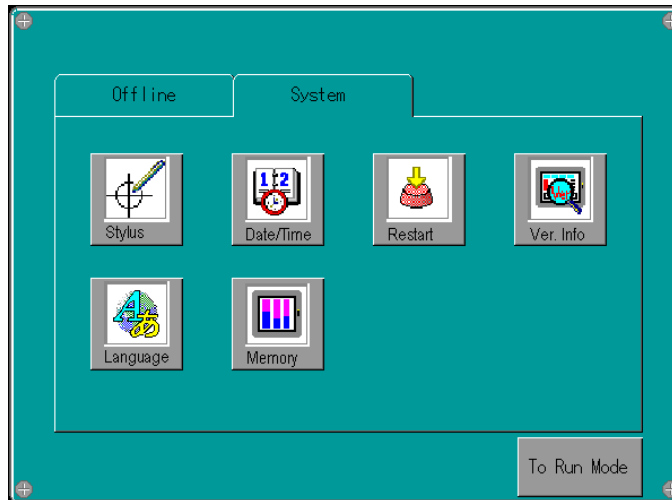

- Stylus
- Date/Time
- Restart
- Ver. Info.
- Language
- Memory

4.1.1 Offline

■ Network

This cannot be set with GP-2401/2501/2601 Series units.

■ Touch Buzzer

The following buzzer sound settings are available.

The factory setting is [Press Touch Object].

- [None] Selecting this will turn the buzzer off.
- [Press Touch Object] The buzzer will only sound when a Touch Object is touched.
- [Press Anyway On Panel] You cannot use this option with the GP units.

◆ Setting Procedure

1. In the [Settings] menu, touch the [Offline] tab.
2. Touch the [Buzzer] icon.
3. Touch/select the desired buzzer mode.

Chapter 4 - Settings

■ Backlight Control

Here, three selections (modes) are available.

- Wait
To preserve the GP unit's screen display elements and extend the life of the backlight, the backlight can be set to automatically turn off after a designated period of inactivity (idle time) elapses. The factory setting for this item is [OFF].
- Enable Touch if Backlight is OFF
This setting designates if the touch panel is enabled or disabled when a backlight burnout is detected. When this feature is set to OFF, touch panel touch input is ignored, thereby preventing touch panel operation errors. The factory setting is [OFF]. (Checkbox is not set.)



Note: Backlight burnout detection is performed via monitoring of the backlight's current consumption. Therefore, certain types of backlight failures cannot be detected.

- Brightness
Four levels of brightness are available.

◆ Setting Procedure

1. In the [Settings] menu, touch the [Offline] tab.
2. Touch the [Backlight] icon.
3. Touch/select the desired backlight brightness.
4. To automatically turn the backlight off after a specified period of time, touch the [Wait] selection and set the "idle time" period.

■ Self Test

Performs the GP unit's self test. For details, see 5.2 Self Test.

■ OP. Switch

This setting item is for GP2000H Series units only.

4.1.2 System

■ Stylus

This setting is not required for GP series units.

■ Date/Time

Sets the GP unit's date and time.

◆ Setting Procedure

1. In the [Settings] menu, touch the [System] tab.
2. Touch the [Date/time] icon.
3. Touch/select the Date or Time field to call up a data entry keypad. Use this keypad to enter all time settings.

■ Restart System

Restarts the GP.

◆ Setting Procedure

1. In the [Settings] menu, touch the [System] tab.
2. Touch the [Restart] icon.
3. Touch/select the [Restart] button to restart the GP unit.

■ Version Information

Calls up the Pro-Designer runtime version, and the version and build numbers for the current project.

◆ Setting Procedure

1. In the [Settings] menu, touch the [System] tab.
2. Touch the [Ver. Info] icon.

■ Language Selection

Designates the language used with System screens and User Applications.

◆ Setting Procedure

1. In the [Settings] menu, touch the [System] tab.
2. Touch the [Language] icon.
3. Touch/select the desired language for the [System] and [User Application] items.

Chapter 4 - Settings

■ Memory

Displays the total amount of memory, and the amount of memory currently being used.

◆ Setting Procedure

1. In the [Settings] menu, touch the [System] tab.
2. Touch the [Memory] icon.

Chapter

5 Troubleshooting

1. Troubleshooting Checklists

2. SELF TEST

This section explains how to find and resolve GP unit problems.

The GP unit can be connected to a wide range of devices, including a host (PLC), however, this manual will not discuss every possible device, or problem. For problems not directly related to the GP unit, refer to that device's manual.

The main problems that occur during use of the GP unit are:

- 1) The panel display is blank.
- 2) Connected devices cannot be used.

5.1 Troubleshooting Checklists

When a problem occurs, be sure to first read each checklist item and follow the instructions given.

If this does not solve the problem, please contact your local GP distributor.

■ When a problem cannot be solved

For hardware and software problems, contact the distributor where you bought the GP unit.

Chapter 5 - Troubleshooting

5.1.1 No display

No.	Check Item/Operation	Y/N	Countermeasure
1	Are all Pro-Designer screens sent to the GP unit?		If not, send to the GP.
2	Is the [Initial Panel ID] set up correctly in Pro-Designer?		If not, enter the [Initial Panel ID] and re-send the screen data.
3	Is the GP unit's status LED lit?		If the LED is orange, the backlight is burned out. Please change the backlight. See "6.3 Replacing the Backlight"
4	Is the voltage level within the designated range?		See "2.1.1 Electrical"
5	Turn the power supply OFF.		
6	Are the power cable terminals correctly connected?		If not, connect the terminals correctly. See "3.2 Wiring Cautions"
7	Turn the power supply ON.		
8	Is the power lamp lit?		If not lit -> Hardware problem
9	Is the backlight lit?		If the backlight is burned out, please change the backlight. See "6.3 Replacing the Backlight"
	Did the above procedure correct the problem?		If not, -> Hardware problem

5.1.2 Connected devices cannot be used

No.	Check Item/Operation	Y/N	Countermeasure
1	Turn the power supply OFF.		
2	Are the power cable terminals correctly connected?		If not, connect the terminals correctly. See "3.2 Wiring Cautions"
3	Is the correct Device/PLC protocol and driver information set up in Pro-Designer?		If not, enter the correct protocol and driver information.
4	Is the Device/PLC connection cable correctly connected?		Refer to the Device/PLC's manual and correctly connect the cable. See "3.2 Wiring Cautions"
	Did the above procedure correct the problem?		If not, -> Hardware problem

5.2 SELF TEST

The GP unit is equipped with a number of self diagnosis features used to check its System and Interfaces for any problems.

5.2.1 SELF TEST item list

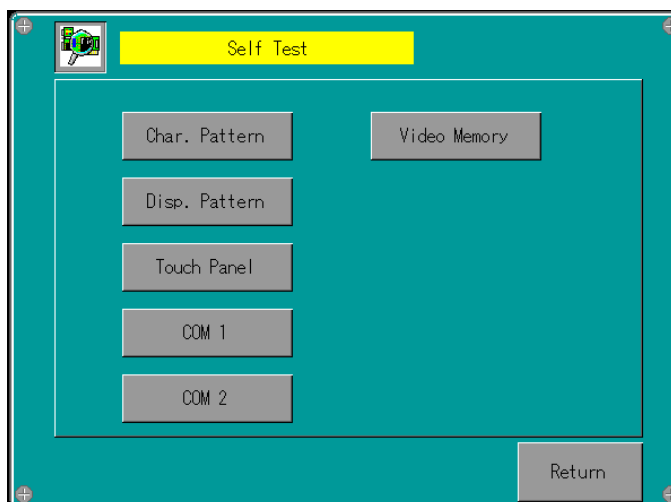
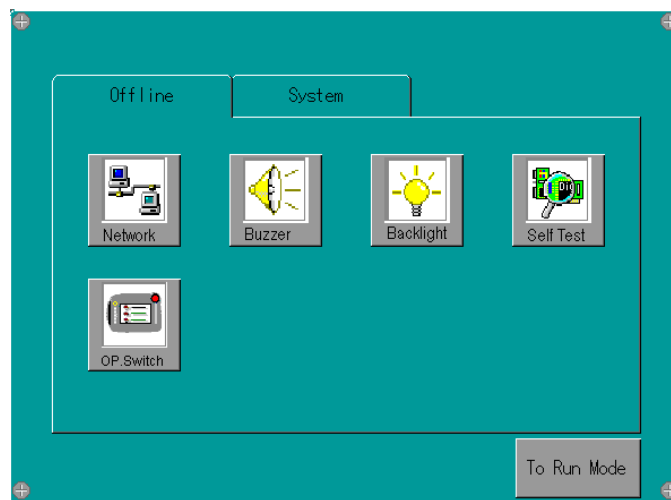

- Char. Pattern
- Disp Pattern
- Touch Panel
- COM 1*1
- COM 2*1*2
- Video Memory

*1 This item must be prepared by the user (cable, connector, etc.).

*2 Cannot be used with GP-2401/2501/2601 Series units.

Chapter 5 - Troubleshooting

5.2.2 SELF TEST - details

This section explains the contents of SELF TEST.

■ Char.Pattern

Checks each font's pattern and kanji-characters'ROM. Used when kanji-characters do not display. If there is no error, the message [OK] will appear, if there is an error, the message [NG] will appear.

■ Disp Pattern

Used when the device contents will not display correctly to check the drawing function.

■ Touch Panel

Touch Panel check. Checks if each touch cell highlights when pressed.

■ COM 1, COM 2*1

Checks the RS-232C and RS-422 SIO lines for areas where communication problems develop. To run the check, connecting the SIO cable is necessary. If all is normal, OK displays; if there is a problem, an error message appears.

The SIO cable wiring is as shown below.

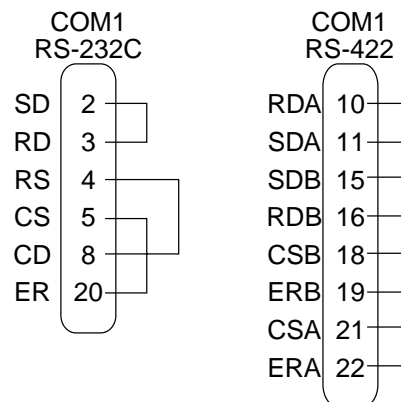

■ Video Memory

This item is used to check video memory (memory used for screen display). Use this feature when your screen display is not correct. This result of this test will be either [OK] (no problem) or [NG](problem).

*1 Cannot be used with GP-2401/2501/2601 Series units.

Chapter 6 Maintenance

1. Regular Cleaning
2. Periodic Check Points
3. Replacing the Backlight

6.1 Regular Cleaning

6.1.1 Cleaning the Display

When the surface or the frame of the display gets dirty, soak a soft cloth in water with a neutral detergent, wring the cloth tightly, and wipe the display.



- Do not use paint thinner, organic solvents, or a strong acid compound to clean the unit.
- Do not use hard or pointed objects to operate the touch-screen panel, since it can damage the panel surface.

6.1.2 Installation Gasket Check/Replacement

The installation gasket protects the GP and improves its water resistance. For instructions on installing the GP's gasket, refer to

Reference *Chapter 3 "Installation and Wiring"*



A gasket which has been used for a long period of time may have scratches or dirt on it, and could have lost much of its water resistance. Be sure to change the gasket at least once a year, or when scratches or dirt become visible.

■ Installation Gasket Attachment Procedure

(The illustrations below show the procedures for the GP-2501T/GP-2501S/GP-2601T models. However, these procedures are also the same for the GP-2401T.)

- 1) Place the GP on a flat, level surface facing the display face downwards.

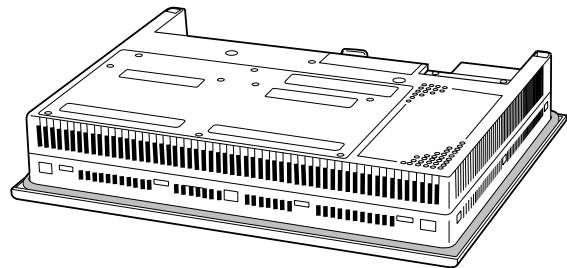

- 2) Remove the gasket from the GP.

Chapter 6 - Maintenance

- 3) Attach the new gasket to the GP.
Be sure to insert the gasket into the GP's groove so that the gasket's groove sides are vertical.

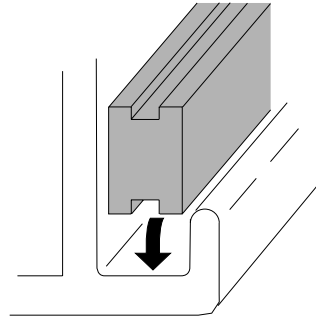

- 4) Check if the gasket is attached to the GP correctly.



- **The gasket must be inserted correctly into the groove for the GP's moisture resistance to be equivalent to IP65f.**
- **Be sure the gasket's seam is not inserted into any of the unit's corners, only in the straight sections of the groove. Inserting it into a corner may lead to its eventually tearing.**
- **The upper surface of the gasket should protrude approximately 2mm out from the groove. Be sure to check that the gasket is correctly inserted before installing the GP into a panel.**

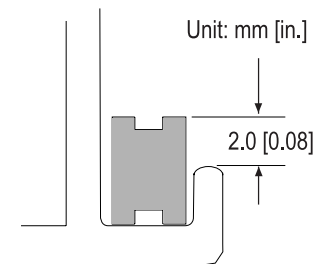
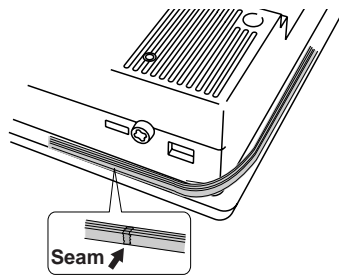

6.2 Periodic Check Points

To keep your GP unit in its best condition, please inspect the following points periodically.

GP Operation Environment

- Is the operating temperature within the allowable range (0°C to 50°C)?
- Is the operating humidity within the specified range (10%RH to 90%RH, dry bulb temperature of 39°C or less)?
- Is the operating atmosphere free of corrosive gasses?

Electrical Specifications

- Is the input voltage appropriate?

GP2501-TC11, GP2501-SC11, GP2601-TC11: AC85V to AC132V or AC85 to AC265V *1

GP2401-TC41-24V : DC19.2V to DC28.8V

Related Items

- Are all power cords and cables connected properly? Have any become loose?
- Are all mounting brackets holding the unit securely?
- Are there many scratches or traces of dirt on the installation gasket?

**1 The products on which Revision "3" is marked conform to the standard requirements.*

▼Reference▲ For more information on how to determine the revision version, refer to section "Revision Version" (page 13).

6.3 Replacing the Backlight

When the unit's backlight burns out, the unit's status LED will turn orange. If the OFFLINE menu's "USE TOUCHPANEL AFTER BACKLIGHT BURNS OUT" feature is set to "NO", the GP's touch panel will be disabled. *1

GP2000 Series units use a CFL, long-life type backlight. The actual life of the backlight however, will vary depending on the GP's operating conditions, and replacement may be required. A GP2000 Series backlight has a life of 50,000 hours (approx. 5.7 years, at 25°C and 24 hour operation), when the backlight is lit continuously (time required for brightness to fall to half its normal level.)



WARNINGS

- **To prevent an electric shock, be sure the GP's power cord is unplugged from the power outlet prior to replacing the backlight.**
- **When the power has just been turned OFF, the unit and backlight are still very hot. Be sure to use gloves to prevent burns.**
- **The backlight is very fragile. Do not touch the glass tube directly or try to remove its power cord. If the glass tube breaks you may be injured.**



Note: Use the following table to check that you have ordered the correct backlight.

GP Model	Backlight Model
GP2401-TC41-24V	PS400-BU00-MS
GP2501-TC11	GP577RT-BL00-MS
GP2501-SC11	PS501S-BU00
GP2601-TC11	PS600-BU00

For backlight replacement details, refer to the replacement backlight unit's installation guide.

**1 If "NO" has been selected for the OFFLINE menu's "FORCE RESET" feature, Touch-Panel operation is disabled.*