

**Panasonic®**

# OPERATING INSTRUCTIONS

## Personal Computer

Model No. **CF-29 Series**



**TOUGHBOOK**

**XP**

**[Additional Manual]**

**Reference Manual**

This manual can be accessed on your computer.  
Refer to page 21 on how to access the Reference Manual.

## Contents

### Getting Started

Read Me First .....	3
Names and Functions of Parts .....	9
First-time Operation .....	11

**Reference Manual**

- Read Me First
- Key Combinations
- LED Indicators

### Operation

Starting Up/Shutting Down .....	17
Touch Pad (Basic Operation) .....	20
Reference Manual .....	21
Useful Information .....	22

**Reference Manual**

- Touch Pad
- Touchscreen
- Panasonic Hand Writing
- Standby/Hibernation Functions
- Security Measures
- Computing on the Road
- Battery Power
- Multimedia Pocket
- PC Cards
- SD Memory Card
- SD Memory Card Security Function
- RAM Module
- Port Replicator
- External Display
- Printer
- USB Devices
- Modem
- LAN
- Wireless LAN
- Hard Disk Drive
- Setup Utility
- Icon Enlarger
- Loupe Utility

### Troubleshooting

List of Error Codes .....	27
Dealing with Problems (Summary) .....	28
Reinstalling Software .....	33

**Reference Manual**

- Technical Information
- DMI Viewer
- List of Error Codes
- Dealing with Problems (Advanced)

### Appendix

LIMITED USE LICENSE AGREEMENT .....	35
Hard Disk Backup Function .....	37
Hard Disk Data Erase Utility .....	41
Specifications .....	43

Getting Started

Operation

Troubleshooting

Appendix

## Customer's Record



Model No.* _____	Dealer's Name _____
Serial No. _____	_____
or	
Code No. _____	Dealer's Address _____
Date of Purchase _____	

\* For the Model No., insert the 12 digit number (for example, CF-29LTQGZBE) located on the bottom of the computer.

## Introduction

Thank you for purchasing the Panasonic computer. Read the operating instructions thoroughly for proper operation of your new computer.

## Illustrations and Terminology in this Manual

- NOTE:** **NOTE** provides a useful fact or helpful information.
- CAUTION:** **CAUTION** indicates a condition that may result in minor or moderate injury.
- Enter** : This illustration means to press the [Enter] key.
- Fn** + **F5** : This illustration means to press and hold the [Fn] key, then press the [F5] key.
- [start] - [Run]: This illustration means to click [start], then to click [Run]. For some applications, you may need to double-click.
- : Where to go for referred information.
-  Reference Manual : This illustration means to refer to the Reference Manual, which is available on your computer. Refer to page 21 on how to access this manual.
- Some of the illustrations in this manual may differ slightly in shape from the actual items in order to make the explanation easier to understand.
  - If the user has logged on without the administrator authority, some functions may not be executable, and some screens may not be displayed as shown in this manual. If this happens, log on with the administrator authority to enable these functions.
  - In this manual, “Microsoft® Windows® XP Professional Service Pack 2 with Advanced Security Technologies” is indicated as “Windows” or “Windows XP”.
  - Confirm the latest information on optional products in catalogs, etc.
  - The “CD/DVD drive” is a description about drives, such as CD-ROM, DVD-ROM & CD-R/RW and DVD MULTI drives.

## Copyright

This manual is copyrighted by Matsushita Electric Industrial Co., Ltd. with all rights reserved. No part of this manual may be reproduced in any form without the prior written permission of Matsushita Electric Industrial Co., Ltd.  
No patent liability is assumed with respect to the use of the information contained herein.

© 2005 Matsushita Electric Industrial Co., Ltd. All Rights Reserved.

## Disclaimer

Computer specifications and manuals are subject to change without notice. Matsushita Electric Industrial Co., Ltd. assumes no liability for damage incurred directly or indirectly from errors, omissions or discrepancies between the computer and the manuals.

## Trademarks

Microsoft, Windows, the Windows logo and IntelliMouse are registered trademarks of Microsoft Corporation of the United States and/or other countries.

Intel, Pentium and PROSet are either registered trademarks or trademarks of Intel Corporation.

SD Logo is a trademark. 

Adobe, the Adobe logo and Adobe Reader are either registered trademarks or trademarks of Adobe Systems Incorporated in the United States and/or other countries.

Panasonic is a registered trademark of Matsushita Electric Industrial Co., Ltd.

Names of products, brands, etc., appearing in this manual are trademarks or registered trademarks of their respective owner companies.

# Read Me First

## For Europe



### Declaration of Conformity (DoC)

“Hereby, we declare that this Personal Computer is in compliance with the essential requirements and other relevant provisions of the Directive 1999/5/EC.”

Hint:

If you want to get a copy of the original DoC of our products which relates to the R&TTE, please contact to our web address: <http://www.doc.panasonic.de>

Contact:

Panasonic Services Europe  
A Division of Panasonic Marketing Europe GmbH  
Panasonic Testing Centre

Network connection.

The terminal equipment is intended for connection to the following public network;

In all the countries of European Economical Area;

- Public Switched Telephony Networks

Technical Features.

The terminal equipment includes the following features;

- DTMF dialing
- Maximum bitrate receiving mode: 56 kbit/s
- Maximum bitrate sending mode: 33.6 kbit/s

This product is designed to interwork with the Public Switched Telecommunication Networks in UK, Ireland, Netherlands, Sweden, Denmark, Finland, Switzerland, Luxembourg, Belgium, France, Germany, Spain, Portugal, Iceland, Greece, Italy, Norway and Austria.

### Declaration of Conformity (DoC)



“Hereby, we declare that this Personal Computer is in compliance with the essential requirements and other relevant provisions of the Directive 1999/5/EC.”

Hint:

If you want to get a copy of the original DoC of our products which relates to the R&TTE, please contact to our web address: <http://www.doc.panasonic.de>

Contact:

Panasonic Services Europe  
A Division of Panasonic Marketing Europe GmbH  
Panasonic Testing Centre

---

### Compliance Notice - CE Mark

This equipment is in conformance with the requirements of the European Council Directive listed below:

73/23/EEC Low Voltage Directive with amendment 93/68/EEC  
89/336/EEC EMC Directive with amendments 92/31/EEC and 93/68/EEC  
1999/5/EC R&TTE

---

# Read Me First

## For U.K.

### Warning

#### **This apparatus must be earthed for your safety.**

To ensure safe operation the three-pin plug must be inserted only into a standard three-pin power point which is effectively earthed through the normal household wiring.

Extension cords used with the equipment must be three-core and be correctly wired to provide connection to earth. Wrongly wired extension cords are a major cause of fatalities.

The fact that the equipment operates satisfactorily does not imply that the power point is earthed and that the installation is completely safe.



For your safety, if you have any doubt about the effective earthing of the power point, consult a qualified electrician.

### **FOR YOUR SAFETY PLEASE READ THE FOLLOWING TEXT CAREFULLY**

This appliance is supplied with a moulded three pin mains plug for your safety and convenience.

A 3 amp fuse is fitted in this plug.

Should the fuse need to be replaced please ensure that the replacement fuse has a rating of 3 amps and that it is approved by ASTA or BSI to BS 1362.

Check for the ASTA mark  or the BSI mark  on the body of the fuse.

If the plug contains a removable fuse cover you must ensure that it is refitted when the fuse is replaced.

If you lose the fuse cover the plug must not be used until a replacement cover is obtained.

A replacement fuse cover can be purchased from your local Panasonic Dealer.

**IF THE FITTED MOULDED PLUG IS UNSUITABLE FOR THE SOCKET OUTLET IN YOUR HOME THEN THE FUSE SHOULD BE REMOVED AND THE PLUG CUT OFF AND DISPOSED OF SAFELY.**

**THERE IS A DANGER OF SEVERE ELECTRICAL SHOCK IF THE CUT OFF PLUG IS INSERTED INTO ANY 13 AMP SOCKET.**

If a new plug is to be fitted please observe the wiring code as shown below.

If in any doubt please consult a qualified electrician.

**Warning: THIS APPLIANCE MUST BE EARTHED.**

### Important

The wires in this mains lead are coloured in accordance with the following code:

Green-and-yellow: Earth  
Blue: Neutral  
Brown: Live

As the colours of the wires in the mains lead of this apparatus may not correspond with the coloured markings identifying the terminals in your plug, proceed as follows:

The wire which is coloured GREEN-and-YELLOW must be connected to the terminal in the plug which is marked by the letter E or by the safety earth symbol  coloured GREEN or GREEN-and-YELLOW.

The wire which is coloured Blue must be connected to the terminal which is marked with the letter N or coloured BLACK. The wire which is coloured Brown must be connected to the terminal which is marked with the letter L or coloured RED.

The mains plug on this equipment must be used to disconnect the mains power.

Please ensure that a socket outlet is available near the equipment and shall be easily accessible.

### How to replace the fuse

Open the fuse compartment with a screwdriver and replace the fuse.

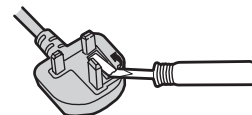

### Warnings

- This equipment is not designed for connection to an IT power system.  
(An IT system is a system having no direct connections between live parts and Earth; the exposed-conductive-parts of the electrical installation are earthed.  
An IT system is not permitted where the computer is directly connected to public supply systems in the U.K.)
- Disconnect the mains plug from the supply socket when the computer is not in use.

This equipment is produced to BS800/1983.

## Pour la France

Bande de fréquences restreinte: Lors de l'utilisation de cet appareil sur le territoire français, vous ne pouvez le faire qu'en utilisant les bandes de fréquences 10 et 11 (respectivement 2.457 MHz et 2.462 MHz). L'utilisation de cet appareil sur une autre bande prise en charge par celui-ci est interdite. Une utilisation à l'extérieur n'est pas autorisée.

## Per l'Italia

Per l'uso negli interni è necessaria una licenza. L'uso con le installazioni esterne non è permesso.

## Important Safety Instructions / Importantes Mesures De Sécurité

When using your telephone equipment, basic safety precautions should always be followed to reduce the risk of fire, electric shock and injury to persons, including the following:

1. Do not use this product near water, for example, near a bath tub, washbowl, kitchen sink or laundry tub, in a wet basement or near a swimming pool.
2. Avoid using a telephone (other than a cordless type) during an electrical storm. There may be a remote risk of electric shock from lightning.
3. Do not use the telephone to report a gas leak in the vicinity of the leak.
4. Use only the power cord and batteries indicated in this manual. Do not dispose of batteries in a fire. They may explode. Check with local codes for possible special disposal instructions.

SAVE THESE INSTRUCTIONS

Certaines mesures de sécurité doivent être prises pendant l'utilisation de matériel téléphonique afin de réduire les risques d'incendie, de choc électrique et de blessures. En voici quelquesunes:

1. Ne pas utiliser l'appareil près de l'eau, p.ex., près d'une baignoire, d'un lavabo, d'un évier de cuisine, d'un bac à laver, dans un sous-sol humide ou près d'une piscine.
2. Éviter d'utiliser le téléphone (sauf s'il s'agit d'un appareil sans fil) pendant un orage électrique. Ceci peut présenter un risque de choc électrique causé par la foudre.
3. Ne pas utiliser l'appareil téléphonique pour signaler une fuite de gaz s'il est situé près de la fuite.
4. Utiliser seulement le cordon d'alimentation et le type de piles indiqués dans ce manuel. Ne pas jeter les piles dans le feu: elles peuvent exploser. Se conformer aux règlements pertinents quant à l'élimination des piles.

CONSERVER CES INSTRUCTIONS

## Information to the User

<Only for models with wireless LAN>

### This product and your Health

This product, like other radio devices, emits radio frequency electromagnetic energy. The level of energy emitted by this product however is far much less than the electromagnetic energy emitted by wireless devices like for example mobile phones.

Because this product operates within the guidelines found in radio frequency safety standards and recommendations, we believe this product is safe for use by consumers. These standards and recommendations reflect the consensus of the scientific community and result from deliberations of panels and committees of scientists who continually review and interpret the extensive research literature.

In some situations or environments, the use of this product may be restricted by the proprietor of the building or responsible representatives of the organization. These situations may for example include:

- Using this product on board of airplanes, or
- In any other environment where the risk of interference to other devices or services is perceived or identified as harmful.

If you are uncertain of the policy that applies on the use of wireless devices in a specific organization or environment (e.g. airports), you are encouraged to ask for authorization to use this product prior to turning on the product.

### Regulatory Information

We are not responsible for any radio or television interference caused by unauthorized modification of this product. The correction of interference caused by such unauthorized modification will be the responsibility of the user. We and its authorized resellers or distributors are not liable for damage or violation of government regulations that may arise from failing to comply with these guidelines.

## Lithium Battery

### Lithium Battery!

This computer contains a lithium battery to enable the date, time, and other data to be stored. The battery should only be exchanged by authorized service personnel.

Warning! A risk of explosion from incorrect installation or misapplication may possibly occur.

### Pile au lithium!

Le micro-ordinateur renferme une pile au lithium qui permet de sauvegarder certaines données comme la date et l'heure notamment. Elle ne devra être remplacée que par un technicien qualifié.

Avertissement! Risque d'explosion en cas de non respect de cette mise en garde!

# Read Me First

## Precautions

THIS PRODUCT IS NOT INTENDED FOR USE AS, OR AS PART OF, NUCLEAR EQUIPMENT/SYSTEMS, AIR TRAFFIC CONTROL EQUIPMENT/SYSTEMS, OR AIRCRAFT COCKPIT EQUIPMENT/SYSTEMS\*<sup>1</sup>. PANASONIC WILL NOT BE RESPONSIBLE FOR ANY LIABILITY RESULTING FROM THE USE OF THIS PRODUCT ARISING OUT OF THE FOREGOING USES.

\*<sup>1</sup> AIRCRAFT COCKPIT EQUIPMENT/SYSTEMS include Class2 Electrical Flight Bag (EFB) Systems and Class1 EFB Systems when used during critical phases of flight (e.g., during take-off and landing) and/or mounted on to the aircraft. Class1 EFB Systems and 2 EFB Systems are defined by FAA: AC (Advisory Circular) 120-76A or JAA: JAA TGL (Temporary Guidance Leaflets) No.36.

Panasonic cannot guarantee any specifications, technologies, reliability, safety (e.g. Flammability/Smoke/Toxicity/Radio Frequency Emission, etc) requirements related to aviation standards that exceed the specifications of our COTS (Commercial-Off-The-Shelf) products.

This computer is not intended for use in medical equipment including life-support systems, air traffic control systems, or other equipment, devices or systems that are involved with ensuring human life or safety. Panasonic cannot be held responsible in any way for any damages or loss resulting from the use of this computer in these types of equipment, devices or systems, etc.

The CF-29 was developed based on thorough research into the real-world portable computing environments. Exhaustive pursuit of usability and reliability under harsh conditions led to innovations such as the magnesium alloy exterior, vibration damped hard disk drive and floppy disk drive, flexible internal connections. The CF-29's outstanding engineering has been tested using the strict MIL-STD- 810F (for vibration and shock) and IP (for dust and water) based procedures.

As with any portable computer device precautions should be taken to avoid any damage. The following usage and handling procedures are recommended.

Before putting the computer away, be sure to wipe off any moisture.

### If a Malfunction Occurs, Immediately Unplug the AC Cord and the Battery Pack

- Computer is damaged
- Foreign object inside computer
- Smoke emitted
- Unusual smell emitted
- Unusually hot

Continuing to use the computer while any of the above conditions are present may result in fire or electric shock.

- If a malfunction occurs, immediately turn the power off and unplug the AC cord, and then remove the battery pack.

### Do Not Touch the Computer and Cable When It Starts Thundering

Electric shock may result.

### Do Not Connect the AC Adaptor to a Power Source Other Than a Standard Household AC Outlet

Otherwise, a fire due to overheating may result. Connecting to a DC/AC converter (inverter) may damage the AC adaptor. On an airplane, only connect the AC adaptor/charger to an AC outlet specifically approved for such use.

### Do Not Do Anything That May Damage the AC Cord, the DC Plug, or the AC Adaptor

Do not damage or modify the cord, place it near hot tools, bend, twist, or pull it forcefully, place heavy objects on it, or bundle it tightly.

Continuing to use a damaged cord may result in fire, short circuit, or electric shock.

### Do Not Pull or Insert the DC Plug If Your Hands Are Wet

Electric shock may result.

### Clean the DC Plug of Dust and Other Debris Regularly

If dust or other debris accumulates on the plug, humidity, etc. may cause a defect in the insulation, which may result in a fire.

- Pull the plug, and wipe it with a dry cloth.
- Pull the plug if the computer is not being used for a long period of time.

### Insert the AC Plug Completely

If the plug is not inserted completely, fire due to overheating or electric shock may result.

- Do not use a damaged plug or loose AC outlet.

### Close the Connector Cover Tightly When Using the Computer Where Is a Lot of Water, Moisture, Steam, Dust, Oily Vapors, etc.

The entry of foreign matter may cause a fire or electric shocks.

- If foreign matter has found its way inside, immediately turn the power off and unplug the AC cord, and then remove the battery pack. Then contact your technical support office.

### Do Not Disassemble the Computer

There are high-voltage areas inside which may give you an electric shock if you should touch them. Do not touch the pins and circuit boards inside, and do not allow foreign matter to enter inside.

Also, remodeling or disassembly may cause a fire.

### Keep SD Memory Cards Away from Infants and Small Children

Accidental swallowing will result in bodily injury.

In the event of accidental swallowing, see a doctor immediately.

### Do Not Place the Computer on Unstable Surfaces

If balance is lost, the computer may fall over or drop, resulting in an injury.

### Avoid Stacking

If balance is lost, the computer may fall over or drop, resulting in an injury.

### Do Not Leave the Computer in High Temperature Environment Such as in a Sun-Heated Car, for a Long Period of Time

Leaving the computer where it will be exposed to extremely high temperatures such as in a sun-heated car or in direct sunlight may deform the cabinet and/or cause trouble in the internal parts. Continued use in such a resulting condition may lead to short-circuiting or insulation defects, etc. which may in turn lead to a fire or electric shocks.

### Hold the Plug When Unplugging the AC Cord

Pulling on the cord may damage the cord, resulting in a fire or electric shock.

### Do Not Move the Computer While the DC Plug Is Connected

The AC cord may be damaged, resulting in fire or electric shock.

- If the AC cord is damaged, unplug the DC plug immediately.

### Use Only the Specified AC Adaptor With Your Computer

Using an AC adaptor other than the one supplied (attached to your computer or supplied by Panasonic) may result in a fire.

### Do Not Subject the AC Adaptor to Any Strong Impact

Using the AC adaptor after a strong impact such as being dropped may result in electric shock, short circuit, or fire.

### Take a Break of 10-15 Minutes Every Hour

Using the computer for long periods of time may have detrimental health effects on the eyes or hands.

**Do Not Turn the Volume Up to Loud When Using Headphones**  
Listening at high volumes that overstimulate the ear for long periods of time may result in loss of hearing.

**Use the Modem with a Regular Telephone Line**

Connection to an internal phone line (on-premise switches) of a company or business office, etc. or to a digital public phone or use in a country or area not supported by the computer may result in a fire or electric shocks.

**Do Not Connect a Telephone Line, or a Network Cable Other Than the One Specified, into the LAN Port**

If the LAN port is connected to a network such as the ones listed below, a fire or electric shock may result.

- Networks other than 1000BASE-TX, 100BASE-TX or 10BASE-T
- Phone lines (Telephone lines, internal phone lines (on-premise switches), digital public phones, etc.)

**Do Not Use with Exposing the Skin to the Computer for a Long Period of Time**

Using the computer with exposing the skin to the heat source of the computer or AC adaptor for a long period of time can cause a low-temperature burn.

- Do not place the computer near a television or radio receiver.
- Keep the computer away from magnets. Data stored on the hard disk may be lost.

● **Interface Cable**

Use of an interface cable longer than 3 m (9.84 feet) is not recommended.

## Precautions (Battery Pack)

**Do Not Use with Any Other Computer**

The battery pack is rechargeable and was intended for the specified computer or charger. If it is used with a computer other than the one for which it was designed, electrolyte leakage, generation of heat, ignition or rupture may result.

**Do Not Charge the Battery Using the Methods Other Than Indicated in This Manual**

If the battery pack is not charged using one of the methods indicated in this manual, electrolyte leakage, generation of heat, ignition or rupture may result.

**Do Not Throw the Battery Pack into a Fire or Expose It to Excessive heat**

Generation of heat, ignition or rupture may result.

**Avoid Extreme Heat (Near the Fire, in Direct Sunlight, for Example)**

Electrolyte leakage, generation of heat, ignition or rupture may result.

**Do Not Insert Sharp Objects into the Battery Pack, Expose It to Bumps or Shocks, Disassemble, or Modify It**

Electrolyte leakage, generation of heat, ignition or rupture may result.

**Do Not Short the Positive (+) and Negative (-) Contacts**

Generation of heat, ignition or rupture may result. Do not place the battery pack together with articles such as necklaces or hairpins when carrying or storing.

**Do Not Use This Computer with a Battery Pack Other Than the One Specified**

Use only the specified battery pack (CF-VZSU29A) with your CF-29. Use of battery packs other than those manufactured and supplied by Panasonic may present a safety hazard (generation of heat, ignition or rupture).

- Do not touch the terminals on the battery pack. The battery pack may no longer function properly if the contacts are dirty or damaged.
- Do not expose the battery pack to water, or allow it to become wet.
- If the battery pack will not be used for a long period of time (a month or more), charge or discharge (use) the battery pack until the remaining battery level becomes 30% to 40% and store it in a cool, dry place.
- This computer prevents overcharging of the battery by recharging only when the remaining power is less than approx. 95% of capacity.
- The battery pack is not charged when the computer is first purchased. Be sure to charge it before using it for the first time. When the AC adaptor is connected to the computer, charging begins automatically.
- Should the battery leak and the fluid get into your eyes, do not rub your eyes. Immediately flush your eyes with clear water and see a doctor for medical treatment as soon as possible.

### NOTE

- The battery pack may become warm during recharging or normal use. This is completely normal.
- Recharging will not commence if internal temperature of the battery pack is outside of the allowable temperature range (0 °C to 50 °C {32°F to 122 °F}). (☞ Reference Manual “Battery Power”) Once the allowable range requirement is satisfied, charging begins automatically. Note that the recharging time varies based on the usage conditions. (Recharging takes longer than usual when the temperature is 10 °C {50 °F} or below.)
- If the temperature is low, the operating time is shortened. Only use the computer within the allowable temperature range.
- This computer has a high temperature mode function that prevents the degradation of the battery in high temperature environments. (☞ Reference Manual “Battery Power”) A level corresponding to a 100% charge for high temperature mode is approximately equivalent to an 80% charge level for normal temperature mode.
- The battery pack is a consumable item. If the amount of time the computer can be run by using a particular battery pack becomes dramatically shorter and repeated recharging does not restore its performance, the battery pack should be replaced with a new one.
- When transporting a spare battery inside a package, briefcase, etc., it is recommended that it be placed in a plastic bag so that its contacts are protected.
- Always power off the computer when it is not in use. Leaving the computer on when the AC adaptor is not connected will exhaust the remaining battery capacity.

## For Used in Motor Vehicle

Warning: Check the following Commission Recommendation to determine proper installation and usage of this product while operating within a motor vehicle.

“Commission Recommendation on safe and efficient in-vehicle information and communication systems: A European statement of principles on human machine interface.”

Commission Recommendation is available from Official Journal of the European Communities.

# Read Me First

## 802.11a Wireless LAN channel

Use the following channels for the 802.11a Wireless LAN.

- U.K., Italy, Sweden, Germany, Finland, Norway  
Channels 36, 40, 44, 48, 52, 56, 60, 64 (available indoors only)  
Channels 100, 104, 108, 112, 116, 120, 124, 128, 132, 136, 140
- Netherlands, Spain, Switzerland  
Channels 36, 40, 44, 48, 52, 56, 60, 64  
Channels 100, 104, 108, 112, 116, 120, 124, 128, 132, 136, 140
- Austria  
Channels 36, 40, 44, 48 (available indoors only)
- France, Belgium  
Channels 36, 40, 44, 48, 52, 56, 60, 64 (available indoors only)

## Information on Disposal for Users of Waste Electrical & Electronic Equipment (private households)



This symbol on the products and/or accompanying documents means that used electrical and electronic products should not be mixed with general household waste.

For proper treatment, recovery and recycling, please take these products to designated collection points, where they will be accepted on a free of charge basis. Alternatively, in some countries you may be able to return your products to your local retailer upon the purchase of an equivalent new product. Disposing of this product correctly will help to save valuable resources and prevent any potential negative effects on human health and the environment which could otherwise arise from inappropriate waste handling. Please contact your local authority for further details of your nearest designated collection point. Penalties may be applicable for incorrect disposal of this waste, in accordance with national legislation.

### For business users in the European Union

If you wish to discard electrical and electronic equipment, please contact your dealer or supplier for further information.

### Information on Disposal in other Countries outside the European Union

This symbol is only valid in the European Union.

If you wish to discard this product, please contact your local authorities or dealer and ask for the correct method of disposal.



# Names and Functions of Parts

The illustrations shown may differ from the actual physical appearances.

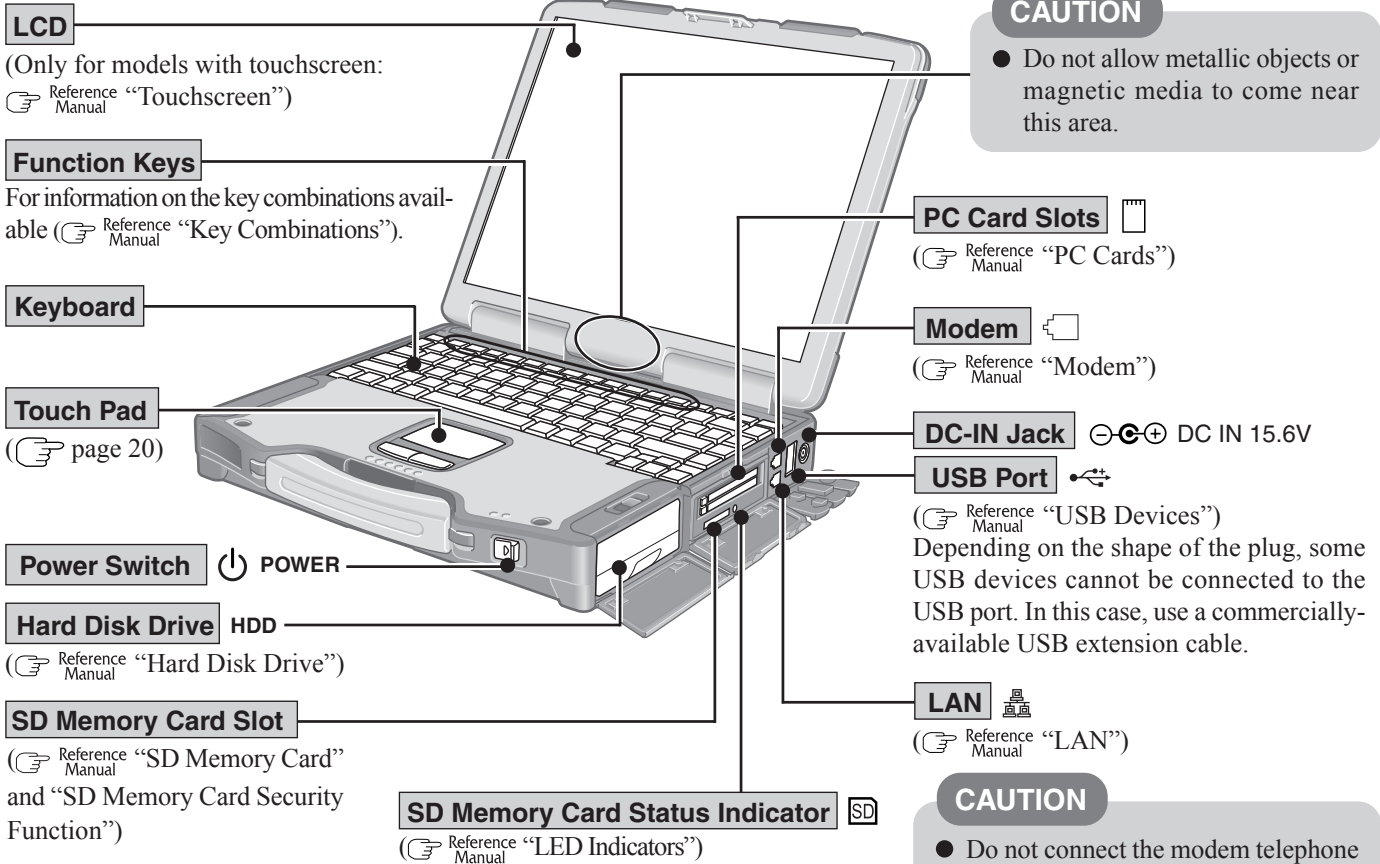

<Only for models with wireless LAN>

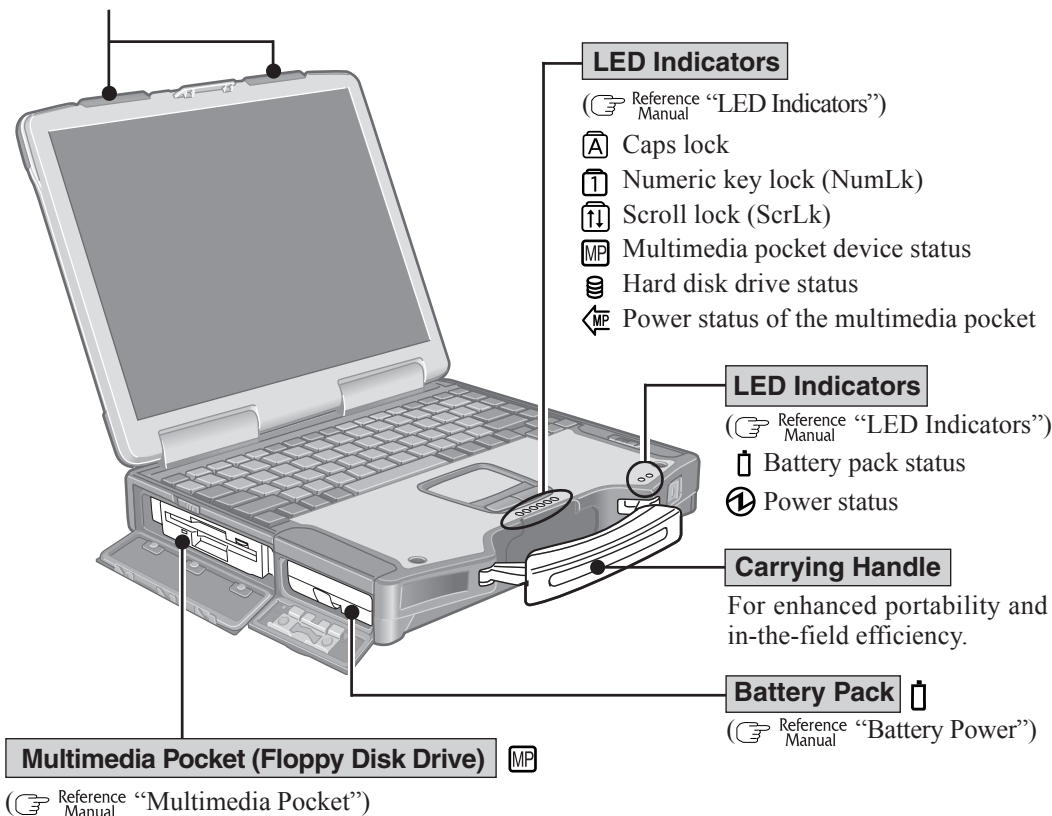

Getting Started

# Names and Functions of Parts

Getting Started

## Headphone Jack

Use this jack to connect headphones or amplifier-equipped speakers. Audio output from the internal speaker is disabled when headphones or external speakers are connected.

## USB Port

 Reference Manual “USB Devices”

Depending on the shape of the plug, some USB devices cannot be connected to the USB port. In this case, use a commercially-available USB extension cable.

## Security Lock LOCK

A Kensington cable can be connected. For more information, read the manual that comes with the cable.

## External Display Port

 Reference Manual “External Display”

## Parallel Port

 Reference Manual “Printer”

## Serial Port

## Expansion Bus Connector

 Reference Manual “Port Replicator”

## Microphone Jack

Use only a monaural condenser microphone (miniature jack). Using an input source other than a monaural condenser microphone may not allow audio to be input or may damage the equipment.

### NOTE

- When using an external microphone, do not remove the check mark for “Mute” under “Microphone Balance” of the Volume Control dialog box and do not increase the playback volume. Howling may result. Howling may occur in the same way when disconnecting an external microphone. (The microphone of “Volume Control” is in the state of mute at the time of factory shipment. This is not shown at the time of factory shipment.)

## RAM Module Slot

 Reference Manual “RAM Module”

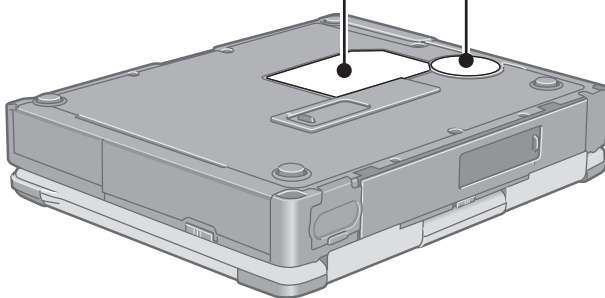

## Speaker

- To adjust the volume: **Fn** + **F5** / **Fn** + **F6**
- Speaker on/off: **Fn** + **F4**

### CAUTION

- Do not allow metallic objects or magnetic media to come near the speaker on the bottom surface of the computer.
  - Because the speaker contains a magnet, metal objects may become attached to the bottom surface of the computer. This may cause the computer to be unstable, or may mark the surface of the desk on which it is sitting.
  - If floppy disks, magnetic memory cards, or other magnetic media approach the speaker, there is a risk that data will be destroyed.

### CAUTION

- Do not cover the computer with a thick cloth, such as a blanket.



# First-time Operation

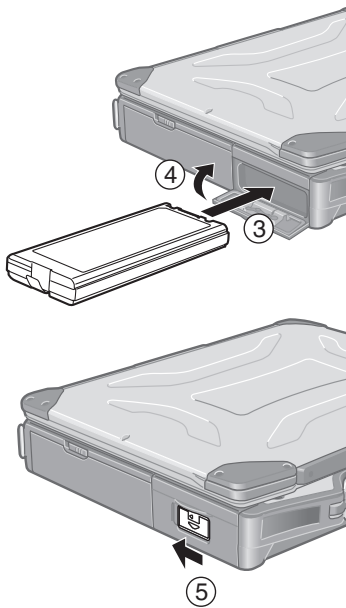

- Slide the battery pack inward until it is firmly in place.

### CAUTION

- Do not touch the terminals on the battery pack and the computer. The battery pack may no longer function properly if the contacts are dirty or damaged. Also, the computer may not operate properly.
- Be sure to insert the battery pack as illustrated.

- Close the cover until it clicks into place.
- Lock the cover by sliding the latch to the left.

### CAUTION

- Confirm that the latch lock is correctly in place. If you carry your computer without the latch lock in place, the battery pack may fall out.
- Before using the battery pack, carefully read “Precautions (Battery Pack)” (page 6-7).

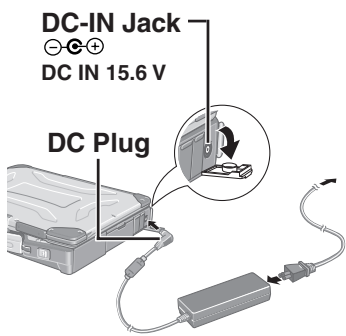

## 4 Connect your computer to a power outlet.

### CAUTION

- Be sure the AC adaptor is connected until completing the first-time use operation.
- When using the computer for the first time, do not connect any peripheral device except the battery pack and AC adaptor to the computer.

#### Handling the AC adaptor

- Do not twist or pull the AC power cord forcefully. Doing so may damage the connections.
- Use only the specified AC adaptor with your computer. Using an AC adaptor other than the one supplied might damage the battery and/or the computer.
- When the DC plug is not connected to the computer, disconnect the AC cord from your AC wall outlet.
- Problems such as sudden voltage drops may arise during periods of thunder and lightning. Since this could adversely affect your computer, an uninterruptible power source (UPS) is highly recommended unless running from the battery pack alone.

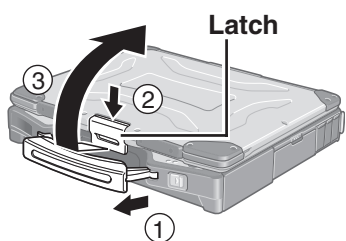

## 5 Open the display.

- Pull the carrying handle forward.
- Press the latch as illustrated.
- Lift up the latch and open the display.

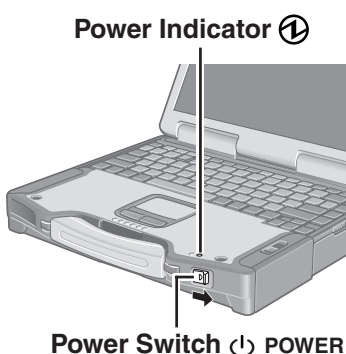

## 6 Turn your computer on.

Slide the power switch and hold it for approximately one second until the power indicator turns on before releasing it.

### CAUTION

- Do not slide the power switch and hold it for more than four seconds; this will cause the power to be turned off forcibly.
- Do not slide the power switch repeatedly.
- Once the computer is powered off, you must wait at least ten seconds before powering it on again.

## 7 Setup Windows.

Moving the cursor  or clicking buttons can be performed with the touch pad. ( page 20)

### NOTE

- The touchscreen does not work properly during the Windows setup.



### CAUTION

- Do not press any keys or touch the touch pad until [Windows XP Professional Setup] is displayed.  
<For MUI OS model>
- Use the touch pad to make selections (e.g., “License Agreement”). Do not use the keyboard during the Windows setup because accidental selections may be made.
- The keyboard will operate as a US keyboard during the Windows setup. Because of this, alphabets that are input may differ from the keyboard display. When inputting numbers, press the NumLock key, and enter numbers in the ten-key mode.

- ① At [Welcome to the Windows XP Setup Wizard], select [Next].
- ② After reading the agreement, select [I accept this agreement] or [I don't accept this agreement], then select [Next].

### NOTE

- If [I don't accept this agreement] is selected, the Windows setup will be aborted.

- ③ Select settings for your region, then select [Next].  
<For MUI OS model>
  - Do not change the settings in [To change system or these settings, click Customize] of [Regional and Language Options] when setting up Windows. The settings will not be properly established.  
Set the language(s) after Windows is set up. ( page 15)
  - To match the keyboard layout with the language, select [Details] in [To view or change your current configuration, click Details] of [Regional and Language Options], and make the setting. ( page 15)  
(This setting is reflected after the completion of Windows Setup.)
- ④ Enter your name and organization and then select [Next].
- ⑤ Enter your computer name and select [Next].

### NOTE

- If you cannot input the character you want because of the difference in keyboard layout, change it after restarting the computer.

- ⑥ Enter the correct date, time and time zone, then select [Next].

### NOTE

- It may take some time before the computer restarts and the screen of step ⑦ is displayed. Wait, and do not press any keys, or touch the touch pad, etc.
- If “An unexpected error has occurred...” (or a similar message) is displayed, select [OK]. This is not a malfunction.

The computer will restart.

Wait until the hard disk drive indicator  has turned off.

# First-time Operation

- ⑦ Select [start] - [Control Panel] - [User Accounts].
- ⑧ Create a password by following the on-screen instructions.

## CAUTION

- Remember this password! If the password is forgotten, Windows cannot be operated.

## NOTE

- When Windows setup is completed, the following message will be displayed at the bottom right of the screen: “Your computer might be at risk.” Continue to the next step.  
The message is generated by the [Security Center] function in [Control Panel], and does not indicate an error or malfunction. For more information about [Security Center]:  page 23.

## 8 <For MUI OS model> Install the Adobe Reader

### NOTE

- Adobe Reader is necessary to read the Important Tips and the Reference Manual, which explains detailed operational procedures concerning your computer.

In [start] - [Run], input the following and select [OK].

English: [c:\util\reader\m\AdbRdr70\_enu\_full.exe]

French: [c:\util\reader\f\AdbRdr70\_fra\_full.exe]

German: [c:\util\reader\g\AdbRdr70\_deu\_full.exe]

Italian: [c:\util\reader\t\AdbRdr70\_ita\_full.exe]

Spanish: [c:\util\reader\p\AdbRdr70\_esp\_full.exe]

Swedish: [c:\util\reader\s\AdbRdr70\_sve\_full.exe]

Dutch: [c:\util\reader\nl\AdbRdr70\_nld\_full.exe]

Finnish: [c:\util\reader\fi\AdbRdr70\_suo\_full.exe]

Norwegian: [c:\util\reader\no\AdbRdr70\_nor\_full.exe]

Install Adobe Reader by following the instructions on the screen.

## 9 Create a new account.

- ① Select [start] - [Control Panel] - [User Accounts] - [Create a new account].
- ② Enter a name for the new account, then select [Next].
- ③ Select [Computer administrator], then select [Create Account].
- ④ <When you want to create a password for the new account>  
Select the new account you have created and select [Create a password].  
Follow the instructions on the screen to create a password.
- ⑤ Select [start] - [Turn Off Computer] - [Restart] to restart the computer.

- Remember this password! If the password is forgotten, Windows cannot be operated. You can create a password reset disk beforehand ( page 16).

### ● When creating a new user account:

- If you make mail settings, create password reset disks ( page 16), or conduct other related operations before creating the user account, you will be unable to use any previous mail history or settings.
- When you create the first new account, you can only select [Computer administrator]. Once a “Computer Administrator” account has been created, you can create additional limited user accounts.  
Note also that only the added user account will be displayed in the Welcome screen. The account for the administrator created during Windows setup will not be displayed.

**NOTE**

- <Only for models with touchscreen>  
If the cursor cannot be pointed correctly with the stylus, calibrate the touchscreen following the procedure below.
  - ① Select [start] - [Control Panel] - [Printers and Other Hardware] - [Mouse] - [TouchScreen] - [Calibration].
  - ② Touch the “+” mark on the calibration screen with the stylus (included) for about one second.
  - ③ After the calibration procedure is executed (e.g., after the nine “+” marks are touched), the procedure ends when **Enter** is pressed.
  - ④ Select [OK].
- About the Icon Enlarger:
  - If the characters or icons on the screen are too small and difficult to see, after completing step **9**, select [start] - [All Programs] - [Panasonic] - [Icon Enlarger]. This will allow you to magnify the display of characters and icons on the screen.
  - The [Icon Enlarger] can be set separately for each account.
- You can also use [Loupe Utility], which enlarges a part of the screen.  Reference Manual “Loupe Utility”
- <Only for models with wireless LAN>  
If you use the wireless LAN, be sure to refer to the Reference Manual’s “Wireless LAN”.

**This concludes the first-time use operation guidelines.**

## Setting Languages <For MUI OS model>

<Languages installed in this computer>

·English    ·French    ·German    ·Italian    ·Spanish    ·Swedish  
·Dutch    ·Finnish    ·Russian    ·Turkish    ·Norwegian

Change the language settings in the following menu.

[Start] - [Control Panel] - [Date, Time, Language, and Regional Options] - [Regional and Language Options]

**[Regional Options] - [Standards and Formats]:**

The currency, weights and measures, and so on, will be displayed according to the locale.

**[Languages] - [Language used in menus and dialogs]:**

The menus and help files of Windows will be displayed in individual languages.

**[Advanced] - [Language for non-unicode Programs]:**

If you will be running non-Unicode programs on the MUI (Multilingual User Interface) system, you should set this menu to match the language of the non-Unicode programs. Since this is a system wide setting, only one language is supported concurrently on the system.

Note that only a user with the administrator authority can change this setting.

# First-time Operation

## NOTE

- When you use MUI OS and localized OS versions together on the same network, use English computer names on localized versions of Windows.
- Some UI (User Interface) strings remain in English even if the user's UI is set to another language. This is because certain strings in some component areas do not work with MUI yet (i.e. remain in English) due to the complexity of the technologies (The main areas include: all 16-bit programs, registry keys and values, and strings in INF files.) This affects about 3% of the User Interface - most of the areas affect administrative tools. Localized systems have all these strings translated.
- If you decide to uninstall a UI language in use by the current user, you must reboot the computer to ensure the language is completely removed or set the UI language back to English first and then uninstall the UI language.
- When saving an MMC (Microsoft Management Console) file, use Latin characters only. Using characters outside the system code page will cause the help file not to display.
- The following components do not switch User Interface language:
  - Welcome screen (The screen that appears when logging on to Windows )
  - MSN Explorer
  - NetMeeting
  - Portions of Internet Connection Wizard
  - HyperTerminal
  - Narrator(not all components listed here)  
For more information, refer to "c:\windows\mui\relnotes.txt".
- If changing the language in [Languages] - [Language used in menus and dialogs], the desktop color will be changed when logging on to Windows next time.  
The desktop color can be changed by following the procedure below.  
Select [start] - [Control Panel] - [Appearance and Themes] - [Display] - [Desktop] and select a color from [Color], then select [OK].

## Information for Windows XP

- Depending on the Windows settings, installed applications, and drivers, menus and other displays may differ, or some functions (such as use of the password reset disk) may be inoperable. Check with your system administrator for details.
- You can select Classic view for the Control Panel or select the Classic Start menu. You can also change the way a user logs on or off.  
The procedure in this manual uses the method or view of the Windows XP default setting (not Classic view or Classic Start menu etc.).
- **Resetting the password**  
Windows XP has a function to reset a forgotten password.  
To use this function, you need to create a password reset disk beforehand following the steps below.
  - 1 Select [start] - [Control Panel] - [User Accounts].
  - 2 Select the account you used to log on and select [Prevent a forgotten password] from [Related Tasks] menu.  
Create a password reset disk following the on-screen instructions.  
Store the password reset disk in a safe place.
    - Only the logon password for each account can be reset.  
The password set in the Setup Utility (  Reference Manual "Setup Utility") cannot be reset.



# Starting Up/Shutting Down

## Starting Up

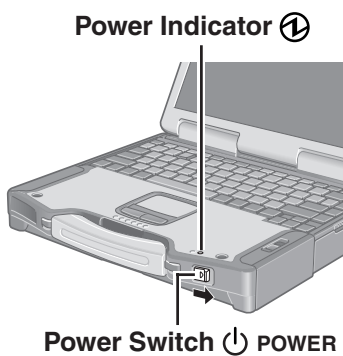
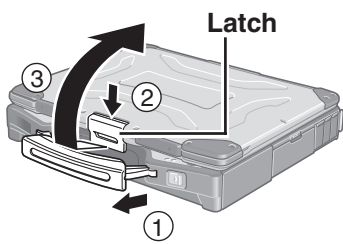

### 1 Open the display.

- ① Pull the carrying handle forward.
- ② Press the latch as illustrated.
- ③ Lift up the latch and open the display.

### 2 Turn your computer on.

Slide the power switch and hold it for approximately one second until the power indicator turns on before releasing it.



#### CAUTION

- When the AC adaptor is not connected, the power will not go on if the display is closed.
- While booting, avoid the following until the hard disk drive indicator  has turned off.
  - Connecting or disconnecting the AC adaptor.
  - Touching the power switch.
  - Performing any keyboard, touch pad, touchscreen (only for models with touchscreen), or external mouse operations.
  - Closing the display.
- Once the computer is powered off, you must wait at least ten seconds before powering it on again.
- When the CPU temperature rises, the computer may not power on to prevent the CPU from overheating. Should this happen, allow the computer to cool down then switch the power on again.  
If the computer still does not power on, contact Panasonic Technical Support.

#### NOTE

- When the power is turned on in a low-temperature environment, sometimes the message “Warming up the system. Please wait...” is displayed (up to 20 minutes) or the battery indicator alternately blinks green and orange. This function is designed to prevent hard disk drive malfunctions that may occur at low temperatures. Wait for the computer to start up.

### 3 Log on to Windows.

After confirming that the hard disk drive indicator  has turned off, select the user and input the password, then select . Until the correct password is entered, the computer will not operate.

### 4 Select your application.

You are able to start working on your computer.

# Starting Up/Shutting Down

## NOTE

- The power saving function is factory set, so if there is no input from a key, the touch pad, the touchscreen (only for models with touchscreen) or an external mouse (when one is connected) for a certain interval of time, the power to the LCD and hard disk may be turned off. The LCD will resume operation when the touch pad, the touchscreen (only for models with touchscreen) or an external mouse (when one is connected) is used or a key is pressed.

The power to the LCD may be turned off even when an application software is being installed. In this case, because it is conceivable that a selection dialog box will be shown, do not press **Space** or **Enter** to attempt to resume from this condition as doing so may trigger a selection, but instead, press a key unrelated to the direct triggering of a selection, like **Ctrl**.

In addition, when the computer is left alone, it automatically enters the standby or hibernation mode. The computer will resume by sliding the power switch. (Reference Manual “Standby/Hibernation Functions”)

## ● If [Enter Password] is displayed

Enter your password\*1 and press **Enter**. (Reference Manual “Security Measures”)

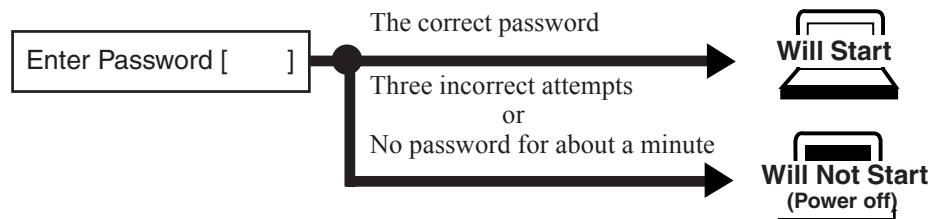

\*1 Supervisor Password or User Password set in the Setup Utility (not the Windows password).

## Shutting Down (power off your computer)

**1** Save important data and close each application.



**2** Select [start] - [Turn Off Computer].

**3** Select [Turn Off].

Your computer will power off automatically.

- Restarting your computer (without shutting down):  
Select [Restart].



● **To shut down using the keyboard;**

Press , , and select [Turn Off] with .

### CAUTION

- Do not do the following during the shutdown/restart procedure.
  - Connecting or disconnecting the AC adaptor.
  - Touching the power switch.
  - Performing any keyboard, touch pad, touchscreen (only for models with touchscreen), or external mouse operations.
  - Closing the display.

### NOTE

- **Note that the computer consumes electricity even when the computer power is off.**  
If the battery pack is fully charged, the battery will fully discharge in Approx. 3 weeks.  
(When second battery pack is attached: Approx. 4 weeks)
- **To quickly resume computer operation after shutting down,**  
The standby or hibernation function is available ( Reference Manual “Standby/Hibernation Functions”).
- **When you leave the computer or interrupt your work...**  
If you use the “Standby” or “Hibernation” function, then when you turn on the power next time, the application software and files you were using before will be displayed, and you can restart the same operations immediately ( Reference Manual “Standby/Hibernation Functions”).

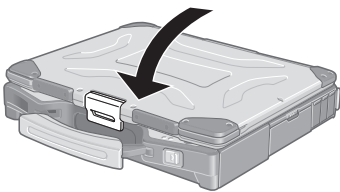



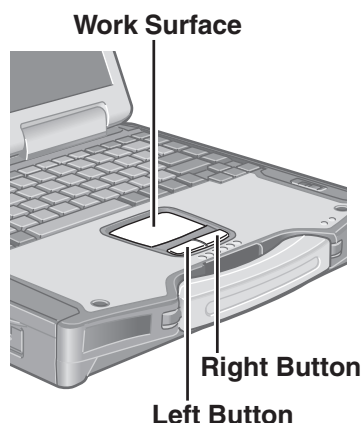

**4** Close the display until the latch clicks into place.

# Touch Pad (Basic Operation)

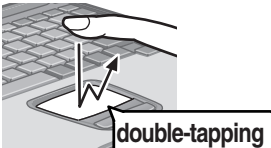
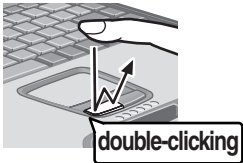

Use the touch pad to move the cursor on the screen and perform computer operations. For more details, refer to <sup>Reference Manual</sup> "Touch Pad".

Function	Touch Pad Operation	
<b>Moving the Cursor</b>	 Move the tip of your finger lightly over the work surface.	
<b>Tapping/Clicking</b>	 tapping	or  clicking
<b>Double-Tapping/Double-Clicking</b>	 double-tapping	or  double-clicking
<b>Dragging</b>	 Two quick taps, but on the second tap leaving your finger down (applying pressure) and moving it on the work surface.	or  While holding down the button, moving your finger on the work surface.

## Handling the Touch Pad

- By design the touch pad is to be used with a finger tip only. Do not place any object on the work surface or press down forcefully with sharp-pointed objects (e.g., nails) or hard objects that can leave marks (e.g., pencils and ball point pens).
- Try to avoid having any harmful substances such as oil, come in contact with the touch pad. The cursor may not work properly in such cases.
- **When the touch pad becomes dirty:**  
Wipe to remove dirt by using a dry soft cloth such as gauze or a soft cloth first applied with detergent diluted with water and then thoroughly wrung.  
Do not use benzene, thinner, or rubbing alcohol. Doing so may adversely affect the surface, e.g., discoloration. In addition, do not use commercially-available household cleaners and cosmetics, as they may contain components harmful to the surface.

# Reference Manual

## Reference Manual / Important Tips

The Reference Manual and the Important Tips can be accessed on your computer. When a printer is connected, these manuals can also be printed.

### ● Reference Manual

The Reference Manual explains functions for you to make greater use of the computer, such as how to add peripheral devices, how the Setup Utility works, and other useful information. (Refer to the cover of this manual for a list of the main contents included.)

### ● How to access the Reference Manual

Select [Reference Manual] in [start].

### ● Important Tips

Important Tips provides information on how to maximize use of the battery pack, which is necessary for computing away from your home or office.

<Only for models with touchscreen>

It also offers helpful explanations on how to use the touchscreen more effectively.

### ● How to access the Important Tips

Select  on the desktop.

Important Tips can also be accessed from [start] - [All Programs] - [Panasonic] - [On-Line Manuals] - [Important Tips].

When the Reference Manual or Important Tips is accessed for the first time, the License Agreement of the Adobe Reader may be displayed. If it is displayed, after reading the agreement, select [Accept] to access the Reference Manual or Important Tips.

Refer to Adobe Reader Help to use the Adobe Reader.

### NOTE

- Illustrations may be difficult to view depending on the magnification. If the illustration is too small, magnify the display.
- If a printer is connected, we recommend printing the pages required. Depending on the printer, the illustrations and display samples may not be printed with a high quality.

# Useful Information

## Usage Environment

### ● Environment

- Operation: Temperature: 5 °C to 35 °C {41 °F to 95 °F}  
Humidity : 30% to 80% RH (No condensation)
- Storage: Temperature: -20 °C to 60 °C {-4 °F to 140 °F}  
Humidity : 30% to 90% RH (No condensation)

Even within the temperature and humidity ranges noted above, using the computer for long periods of time in an environment with exceptionally low or high temperatures or high humidity may result in deterioration of the product, which can lead to a reduction in product life.

#### NOTE

- Only use the computer within the allowable temperature range.  
When the computer is left powered on in a low temperature environment, set [Turn off hard disks] to [Never] in the following menu to avoid damage to the hard disk drive.  
[start] - [Control Panel] - [Performance and Maintenance] - [Power Options] - [Power Schemes]

### ● Places not to use your computer

- Such areas may result in damage to the computer.

#### Areas with electronic equipment

These areas may interfere with your display or cause your computer to produce strange sounds.

#### Areas with extremely high/low temperatures

- Do not leave things near the computer that are sensitive to heat. During operation, the computer may become warm.
- Before putting the computer away, be sure to wipe off any moisture.

## Handling

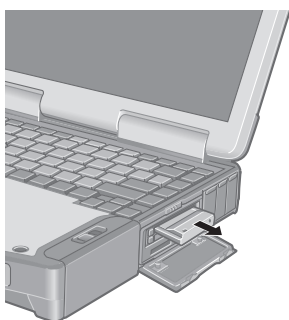

This computer has been designed so as to minimize shock to the LCD and hard disk drive, the leakage of liquid (e.g., water) on to the keyboard, etc., but no warranty is provided against such trouble. Therefore, as a precision instrument, be extremely careful when handling.

#### When carrying the computer, be sure to keep to the following:

- Turn off the computer.
- Remove all external devices, cables, PC Cards protruding from the computer (see figure on the left) and SD Memory Cards before transporting the computer.
- Do not drop or hit your computer against solid objects.
- Do not place the computer upright or allow it to tip over. When the computer receives extremely strong shock after falling, the hard disk or floppy disk drive, etc., may become inoperable.
- Do not carry the computer while the display is open, or carry it by gripping the display.
- Do not put anything (e.g., a piece of paper) between the display and keyboard.
- When taking an airplane, always carry your computer with you. Never check it in with luggage. Before using the computer inside an airplane, we recommend asking the airlines regarding their policy on this issue.
- Do not leave a disk in the drive while transporting your computer.
- When transporting a spare battery pack inside a package, briefcase, etc., it is recommended that it be placed in a plastic bag in order to protect its contacts.

#### We recommend the following:

- Preparing a fully charged battery pack (and optional charger, if possible).
- Making backup copies on discs and carrying them with you.

## Maintenance

### Display (LCD)

#### <Models with touchscreen>

Use the Soft Cloth included with the computer. (For more information, refer to “Suggestions About Cleaning the LCD Surface” that come with the Soft Cloth.)

If the Protective Film becomes damaged, it may be time to replace your Protective Film. The Protective Film is a disposable item. To find out the model number of your Protective Film, contact Panasonic Technical Support. (For more information, refer to the “Operating Instructions” that come with the Protective Film.)

#### CAUTION

- Do not touch or use a touchscreen before you re-attach a Protective Film, as you may leave a mark or a scratch on the touchscreen.

#### <Models without touchscreen>

Avoid using water when cleaning the panel. Ingredients included in water may leave scratches and reduce readability of the screen.

#### <When cleaning dust/dirt>

Avoid rubbing off dust/dirt with cloth since it may leave scratch on the screen.

Sweep dust/dirt with fine brush, then wipe it with a dry soft cloth used for cleaning glasses.

#### <When cleaning oily surface>

Apply camera lens cleaner on a soft gauze and clean it with gentle force. Then, wipe with a dry soft cloth used for cleaning glasses.

### Areas excluding the display

Wipe these areas with a soft cloth, after applying water or detergent diluted with water to the soft cloth and firmly wringing out excess water.

#### CAUTION

- Do not use benzene, thinner, or rubbing alcohol. Doing so may adversely affect the surface, e.g., discoloration. In addition, do not use commercially-available household cleaners and cosmetics, as they may contain components harmful to the surface.
- Do not directly add or spray water or detergent. If liquid enters the inside of the computer, it may cause it to work improperly or be damaged.

## Security Center/Antivirus Protection

Use the Windows Security Center function to protect Windows from damage by computer viruses, etc.

### Windows Security Center

#### ● What is Windows Security Center?

The Windows Security Center allows centralized management of Windows security information, and monitors antivirus measures and other Windows security settings to ensure optimum safety.

Use the Windows Security Center function to protect your computer from damage by viruses, etc.

Select [start] - [Control Panel] - [Security Center] to display the current settings for the following security functions.

#### • Windows Firewall

A security system for protecting the computer from unauthorized access via the Internet or other external networks.

The firewall regulates the data exchanged between the computer and the external network, so that only approved data can pass through.

At the time of purchase, the Windows Firewall is set to be enabled.

# Useful Information

- Automatic Updates

If your computer is connected to the Internet, this function regularly checks whether security updates and other important updates have been made available, and automatically installs these updates in their latest conditions.



- Virus Protection

This function regularly checks whether antivirus software has been installed in the computer, and whether the version of that software is the latest version available.

### NOTE

- Some network-related software and some online network games do not operate normally if the Windows Firewall is enabled. Ask the software manufacturer about the Windows Firewall in the case of using such software.
- For further details on the Windows Firewall, see the help displayed by the following methods:
  - ① Select [start] - [Help and Support].
  - ② Input [Windows Firewall] into [Search] and select .
  - ③ Select [Windows Firewall overview].

## If the message “Your computer might be at risk” is displayed

Read the message, select  (red icon) on the taskbar, and make the appropriate settings. This message, which the Windows Security Center ( page 23) displays to confirm the security-related settings regularly, will be displayed until the settings are made more properly.

### NOTE

- This message does not indicate an error. You can use the computer while the message is displayed. However, in order to operate the computer more safely, we recommend making the appropriate measures to reduce damage from virus and other attacks, thus avoiding the appearance of this message.

## The Pop-up Blocker

In Windows XP, security functions have been strengthened with regard to Web contents. One of these is the “Pop-up Blocker,” which may prevent some Web pages from being displayed.

## Computer Viruses

**Users are advised to purchase the latest versions of virus protection software and use them regularly.**

We recommend you run the software:

- When booting your computer.
- After receiving data.

We recommend that you check data received on disks or from external sources, such as data downloaded from the Internet, e-mail, etc. (For compressed files, uncompress them before running a check).

For Data Execution Prevention (DEP), you can make one of the settings in the following menu. [start] - [Control Panel] - [Performance and Maintenance] - [System] - [Advanced] - [Settings] (in [Performance]) - [Data Execution Prevention].

For more information, refer to Windows help.

## Windows Update



You can use the latest patches and service packs for Windows with the following menus.

**Do not apply “Driver Updates” even if a message to update a driver appears. If a driver update is required, contact to Panasonic Technical Support.**

[start] - [All programs] - [Windows Update]



## Saving Data on the Hard Disk

- **Do not expose your computer to shock.**  
Use care when handling your computer, shock may damage your hard disk or make your software applications and data unusable.
- **Do not power off your computer while software applications are running or hard disk drive indicator  is on.**  
Properly shut Windows down to avoid problems.
- **Save all valuable data to disks.**  
Backing up data to disks will limit damage should trouble occur to your computer or should you inadvertently change or erase data.
- **Use the security function for all important data.** ( Reference Manual “Security Measures” and “SD Memory Card Security Function”)

### Hard Disk Lock

When the Hard Disk Lock is set to [Enable], it is impossible to read/write data from/to the hard disk when the hard disk is installed in a different computer. When the hard disk is returned to the original computer, you can read/write data as before. In this case, however, make the settings in the Setup Utility exactly the same as they were before the hard disk was removed. (Note that this Hard Disk Lock does not guarantee the complete protection of data.) ( Reference Manual “Security Measures”)

## Saving Data on Floppy Disks

- **Do not power off your computer or press the floppy disk drive eject button while the multimedia pocket device indicator  is on.**  
Doing so may damage the data on the floppy disk and render the floppy disk useless.
- **Use care when handling floppy disks.**  
To protect the data on your floppy disks or to prevent a floppy disk from becoming stuck in your computer, avoid the following:
  - Sliding the shutter on the floppy disk manually.
  - Exposing the floppy disk to a magnetic field.
  - Storing the floppy disk in locations prone to high temperatures, low pitched noise, dampness, or dust.
  - Applying more than one label on the floppy disk.
- **Confirm the contents of a floppy disk before formatting it.**  
Confirm that no important data is on the floppy disk, because all data on the floppy disk will be erased.
- **Use the write-protect tab.**  
This is a must for preserving important data. This prevents your data from being erased or overwritten.

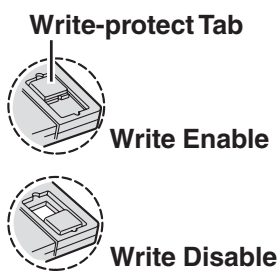

## When Using Peripheral Devices

- Pay strict attention to the following points to avoid damage to the computer, peripheral devices, cables, etc. Also, in addition to following this manual and the Reference Manual, carefully read the instruction manuals for the peripheral devices being used.
- Use only peripheral devices that conform to the computer’s specifications.
  - Connect the devices properly, paying close attention to the condition and position of the connectors.
  - If a connection cannot be made easily, do not apply undue force; check once more to confirm the condition and position of the connector (alignment of pins, etc.) .
  - If the connector has holding screws, fasten the screws firmly.
  - Do not carry the computer with cables attached, and do not pull on the cables forcefully.

# Useful Information

## When Changing Hard Disk Partitions

When using the hard disk backup function, divide the hard disk into partitions when a backup area is created. (☞ page 37) If you divide the hard disk into partitions before creating the backup area, the backup area cannot be created.

## When Disposing of or Transferring Ownership of This Device

When disposing of or transferring ownership of this device, erase all data on the hard disk in order to prevent the theft of hard disk data. Even if you delete data or initialize the hard disk through normal Windows commands, data can still be read using special software. In order to erase all data, either have the data erased by a specialist (at a charge) or use the hard disk data erase utility (included) (☞ page 41). (Note that this hard disk data erase utility does not guarantee that data will be completely erased.)

**Also, note that if you transfer ownership of this device without deleting commercial software that you have installed to the hard disk, you may be in violation of the licensing agreement for that software.**

## Wireless LAN (only for models with wireless LAN)

- **To prevent theft of data or unauthorized access to the hard disk via a wireless LAN**

If you plan to use wireless LAN functions, we recommend that you do so only after making the appropriate security settings, such as for data encryption.

# List of Error Codes

When turning on the computer, if one of the following error codes or messages is displayed, follow the instructions shown below. If the problem persists, or if the error code or message displayed is not shown here, contact Panasonic Technical Support.

Error Code/Message	Action
<b>0211: Keyboard error</b>	<ul style="list-style-type: none"> <li>● If an external keyboard or mouse is connected, disconnect these devices.</li> </ul>
<b>0251: System CMOS checksum bad - Default configuration used</b>	<p>An error has occurred in the memory that stores the Setup Utility settings. This error occurs when the memory content is changed through some inadvertent operation by a program or other function.</p> <ul style="list-style-type: none"> <li>● Run the Setup Utility and load the default values, then change the settings to the appropriate values as needed.</li> <li>● If the problem persists, the internal clock battery may need to be replaced. Contact Panasonic Technical Support.</li> </ul>
<b>0271: Check date and time settings</b>	<p>The date and time setting are incorrect.</p> <ul style="list-style-type: none"> <li>● Run the Setup Utility and set the date and time correctly.</li> <li>● If the problem persists, the internal clock battery may need to be replaced. Contact Panasonic Technical Support.</li> </ul>
<b>0280: Previous boot incomplete - Default configuration used</b>	<p>Startup has failed repeatedly, so the Setup Utility settings have been returned to their default values, and the computer has been booted.</p> <ul style="list-style-type: none"> <li>● Run the Setup Utility and load the default values, then change the settings to the appropriate values as needed.</li> </ul>
<b>02B0: Diskette drive A error</b>	<ul style="list-style-type: none"> <li>● Disconnect the floppy disk drive and reconnect it. Make sure the drive is secured correctly.</li> </ul>
<b>0613: Serial Port*<sup>1</sup> configuration changed</b> <b>0614: Serial Port*<sup>1</sup> config. error - device disabled</b> <sup>*1</sup> The port name, such as A or B, is displayed, indicating the conflicting ports.	<p>I/O address and IRQ settings are in conflict.</p> <ul style="list-style-type: none"> <li>● Run the Setup Utility and change the settings in [Advanced] menu so there is no port conflicts.</li> </ul>
<b>Press &lt;F2&gt; to Setup</b>	<ul style="list-style-type: none"> <li>● Write down the error details and press <b>(F2)</b> to run the Setup Utility. Confirm the settings, and change the settings to the appropriate values as needed.</li> </ul>
<b>Operating System not found</b>	<p>The OS is not properly installed on the floppy disk or the hard disk that you are trying to boot from.</p> <ul style="list-style-type: none"> <li>● If the computer cannot be booted from the floppy disk, check the floppy disk drive to ensure that the disk is in fact bootable, and use another bootable disk if not.</li> <li>● If the computer cannot be booted from the hard disk, confirm whether the hard disk is properly recognized in [Information] menu of the Setup Utility.             <ul style="list-style-type: none"> <li>• If the hard disk is recognized, perform the reinstallation procedure.</li> <li>• If not, contact Panasonic Technical Support.</li> </ul> </li> <li>● If a device is connected to the USB port, disconnect the device, or run the Setup Utility and set [Legacy USB Support] in [Advanced] menu to [Disable].</li> </ul>
<b>Extended RAM Module Failed</b>	<ul style="list-style-type: none"> <li>● If the extended RAM module has not been inserted properly, or if an extended RAM module other than one matching the specifications has been inserted, a beep will sound and the message “Extended RAM Module Failed” will be displayed when turning the power on. In this case, turn the power off, confirm that the extended RAM module meets the specifications, and reinsert it.</li> </ul>

## ● To run the Setup Utility

- 1 Restart the computer.
- 2 Press **(F2)** while [Panasonic] boot screen is displayed soon after the computer begins the startup procedure.

# Dealing with Problems (Summary)

When a problem occurs, refer to this page. The “Reference Manual” also contains detailed information. If a problem appears to be related to a software application, read the software related manual. If you still cannot troubleshoot the problem, contact Panasonic Technical Support. You can use the PC Information Viewer to check the computer’s usage status. (☞ Reference Manual “Dealing with Problems (Advanced)”)

## ● Starting Up

<p><b>The power indicator is not lit</b></p>	<ul style="list-style-type: none"> <li>● Check the cable connection for the AC adaptor.</li> <li>● Check to see if a charged battery pack is properly installed.</li> <li>● Remove the battery pack and disconnect the AC adaptor, then connect them again.</li> </ul>
<p><b>The computer does not operate when a USB device is connected</b></p>	<ul style="list-style-type: none"> <li>● The computer may not operate when certain USB devices are connected. Disconnect the USB device, or set [Legacy USB Support] to [Disable] in [Advanced] menu of the Setup Utility.</li> </ul>
<p><b>[Enter Password] is displayed</b></p>	<ul style="list-style-type: none"> <li>● Input your Supervisor Password or User Password. If you have forgotten it, contact Panasonic Technical Support.</li> </ul>
<p><b>POST Startup Error(s) is displayed</b></p>	<p>☞ page 27</p>
<p><b>Windows startup, or an operation is extremely slow</b></p>	<ul style="list-style-type: none"> <li>● Press <b>(F9)</b> in the Setup Utility (☞ <small>Reference Manual</small> “Setup Utility”). This will restore the Setup Utility’s settings to their default values (except the password settings). Then, the Setup Utility must be run once again for you to input the appropriate operating environment settings. (The processing speed depends on the application software used, so this operation may not cause the processing speed to increase.)</li> <li>● If you install resident software after purchasing this computer, disable the resident software.</li> <li>● When Indexing Service is enabled, Windows operation becomes slower. Disable Indexing Service in the following menu. [start] - [Search] - [Change preferences] - [Without Indexing Service]</li> </ul>
<p><b>The date and time are incorrect</b></p>	<ul style="list-style-type: none"> <li>● You can set the date and time using the following menu. [start] - [Control Panel] - [Date, Time, Language, and Regional Options] - [Date and Time]</li> <li>● When the computer is connected to a LAN, confirm the date and time of the server.</li> <li>● If you continue to experience problems, the internal battery maintaining the clock may need to be replaced. Contact Panasonic Technical Support.</li> <li>● This computer will not correctly recognize the date and time starting from the year 2100 A.D.</li> </ul>
<p><b>When resuming from the standby or hibernation mode, [Enter Password] does not appear even if a password has been set in the Setup Utility</b></p>	<ul style="list-style-type: none"> <li>● Even when a password has been set in [Security] menu of the Setup Utility, [Enter Password] does not appear when the computer resumes from the standby or hibernation mode. If you want to use the security function when using the standby or hibernation mode, use the Windows password as follows:             <ol style="list-style-type: none"> <li>1 Select [start] - [Control Panel] - [User Accounts], and select the account for which the password will be set.</li> <li>2 Select [Create a password], input the password, and then [Create Password].</li> <li>3 Add the check mark for [Prompt for password when computer resumes from standby] in [Control Panel] - [Performance and Maintenance] - [Power Options] - [Advanced].</li> </ol> </li> </ul>
<p><b>When the administrator password is forgotten</b></p>	<ul style="list-style-type: none"> <li>● If you have created a password reset disk (☞ page 16), a message is displayed when you fail to correctly enter the password. Follow the message’s instructions and set the password again by using the password reset disk. If you have not created a password reset disk, after reinstalling, setup Windows and then set the password again.</li> </ul>
<p><b>When “Remove disks or other media. Press any key to restart” (or a similar message) is displayed</b></p>	<ul style="list-style-type: none"> <li>● This means a floppy disk that does not contain system startup information has been left in the floppy disk drive. Remove the floppy disk, and press any key.</li> <li>● This message may appear when certain USB devices are connected. Remove the USB device, or set [Legacy USB Support] in [Advanced] menu of the Setup Utility to [Disable].</li> <li>● If the message still appears even after trying the above two measures, this may be an indication that some type of hard disk failure has occurred. Contact Panasonic Technical Support.</li> </ul>
<p><b>[Executing Battery Recalibration] screen is displayed</b></p>	<ul style="list-style-type: none"> <li>● When Windows is shut down during the Battery Recalibration procedure, if you select [Cancel] in the [End Program] screen, Windows shutdown is aborted. In this case, Battery Recalibration will begin the next time the computer is started. To start up Windows, turn off the computer by sliding the power switch, and then turn it back on again.</li> </ul>

## Starting Up (continued)

When the previous item is not the cause	<ul style="list-style-type: none"> <li>● Press <b>(F9)</b> in the Setup Utility (☞ <small>Reference Manual</small> “Setup Utility”). This will restore the Setup Utility’s settings to their default values (except the password settings).</li> <li>● Try removing all peripheral devices.</li> <li>● Check a disk error using the following procedure.             <ol style="list-style-type: none"> <li>1 Select [start] - [My Computer], right-click [Local Disk(C:)], and then select [Properties].</li> <li>2 Select [Tools] - [Check Now].</li> <li>3 Select [Start] after selecting required items in [Check disk options].</li> </ol> </li> <li>● At startup, hold down <b>(F8)</b> when [Panasonic] boot screen disappears*<sup>1</sup>, and release your finger when the Windows Advanced Options Menu is displayed. Start the computer in Safe Mode, and confirm the details of the error.             <p>*<sup>1</sup> When [Password on boot] is set to [Enable], [Enter Password] appears after the [Panasonic] boot screen disappears. Hold down <b>(F8)</b> soon after inputting the password and pressing <b>(Enter)</b>.</p> </li> </ul>
---	--

## Entering Password

On the [Enter Password] screen, a beep sounds and the password cannot be entered	<ul style="list-style-type: none"> <li>● The computer may be in ten-key mode. If the NumLk indicator <b>(NumLk)</b> lights, press <b>(NumLk)</b> to disable the ten-key mode, and then input.</li> </ul>
Even after entering the password, [Type your password] is displayed again	<ul style="list-style-type: none"> <li>● The computer may be in ten-key mode. If the NumLk indicator <b>(NumLk)</b> lights, press <b>(NumLk)</b> to disable the ten-key mode, and then input.</li> <li>● The computer may be in Caps Lock mode. If the Caps Lock indicator <b>(Caps Lock)</b> lights, press <b>(Caps Lock)</b> to disable the Caps Lock mode, and then input.</li> </ul>

## Display

No display after powering on	<ul style="list-style-type: none"> <li>● When there is no display to an external display,             <ul style="list-style-type: none"> <li>• Check your cable connection to the external display.</li> <li>• Confirm your display is powered on.</li> <li>• Check the settings for your external display.</li> </ul> </li> <li>● The display destination may be set to the external display. Try changing the display destination by pressing <b>(Fn) + (F3)</b>. If you want to switch the display destination repeatedly by pressing <b>(Fn) + (F3)</b>, make sure that the display destination has switched completely each time before pressing <b>(Fn) + (F3)</b> again.</li> <li>● Press <b>(Fn) + (F2)</b> and adjust the LCD brightness.</li> </ul>
The power has not been turned off, but after a certain period of time, there is no display	<ul style="list-style-type: none"> <li>● Has the computer been set to the power-saving mode? To resume operation of your computer from the condition the power of the display is off (for energy conservation purposes), press any key unrelated to the direct triggering of a selection, like <b>(Ctrl)</b>.</li> <li>● To save power, your computer may have automatically entered the standby mode (power indicator blinks green) or hibernation mode (power indicator turns off). In such cases, slide the power switch.</li> </ul>
When the battery pack is used, the screen is darker than when the AC adaptor is connected	<ul style="list-style-type: none"> <li>● Press <b>(Fn) + (F2)</b> and adjust the LCD brightness. Note, however, that when the LCD brightness is increased, the battery running time will become shorter. The LCD brightness can be set to separate levels for when the AC adaptor is connected and when it is disconnected.</li> </ul>
The LCD brightness changes a number of times when the AC adaptor is disconnected	<ul style="list-style-type: none"> <li>● Intel(R) Display Power Saving Technology (☞ <small>Reference Manual</small> “Computing on the Road”) is active and automatically changes the LCD brightness.</li> </ul>
Image colors are not reproduced as expected when displaying photographs or other images	<ul style="list-style-type: none"> <li>● We recommend removing the check mark from [Intel(R) Display Power Saving Technology]. (☞ <small>Reference Manual</small> “Computing on the Road”)</li> </ul>

# Dealing with Problems (Summary)

## ● Display (continued)

An afterimage appears (e.g., green, red, and blue dots remain on the display) or there are dots not displaying the correct colors	<ul style="list-style-type: none"> <li>● If an image is displayed for a prolonged period of time, an afterimage may appear. This is not a malfunction. The afterimage will disappear when a different screen is displayed.</li> <li>● High-precision and advanced technologies are necessary in the production of color liquid crystal displays (color LCDs). Therefore, if 0.002% or less of the picture elements either fail to light or remain constantly lit (that is, more than 99.998% of elements are functioning properly), no defect is considered to exist.</li> </ul>
The screen becomes disordered	<ul style="list-style-type: none"> <li>● The screen display may become distorted if the resolution or number of colors is changed, or if an external display is connected or disconnected while the computer is operating. Restart the computer.</li> </ul>
The external display no longer displays properly	<ul style="list-style-type: none"> <li>● When an external display not compatible with the power saving mode is used with the computer, the display may not function correctly when the computer enters the power saving mode. In such cases, turn off the power to the external display.</li> </ul>
When you want to display the fonts or icons at a larger size	<ul style="list-style-type: none"> <li>● Change the size of the icons, etc. using “Icon Enlarger” (☞ <small>Reference Manual</small> “Icon Enlarger”).</li> <li>● To enlarge a part of the screen, use Loupe Utility (☞ <small>Reference Manual</small> “Loupe Utility”).</li> </ul>
During simultaneous display, one of the screens becomes disordered	<ul style="list-style-type: none"> <li>● Try changing the display by pressing <b>(Fn) + (F3)</b>.</li> <li>● If you continue to experience problems, try changing the display destination in the following menu. [start] - [Control Panel] - [Other Control Panel Options] - [Intel(R) GMA Driver for Mobile] - [Devices]</li> <li>● When the [Command Prompt] is set to “Full Screen” by pressing <b>(Alt) + (Enter)</b>, the picture is displayed on one of the screens only. When the window display is restored by pressing <b>(Alt) + (Enter)</b>, the picture is displayed on both screens.</li> </ul>
When a video such as an MPEG file is being played with Media Player, the display destination cannot be switched using <b>(Fn) + (F3)</b>	<ul style="list-style-type: none"> <li>● The display destination cannot be switched while a video such as an MPEG file is playing. Stop playing the moving picture before switching the display destination.</li> </ul>
When the screen saver is set, an error occurs during a resume operation	<ul style="list-style-type: none"> <li>● When the computer automatically enters the standby or hibernation mode while the screen saver is running, an error may occur during a resume operation. In such cases, turn off the screen saver or try changing the pattern of the screensaver.</li> </ul>

## ● Shutting Down

Windows cannot be shut down or restarted	<ul style="list-style-type: none"> <li>● If a USB device is connected, try removing it.</li> <li>● It may take one or two minutes to shut down.</li> </ul>
--	--





## ● Battery Indicator

The red indicator lights	<ul style="list-style-type: none"> <li>● The battery level is very low (the charge is approx. 9% or less). Connect the AC adaptor. You can use the computer when the battery indicator light is orange. If you do not have an AC adaptor, save your data and power off your computer. After replacing the battery pack with a fully charged one, turn your computer on.</li> </ul>
The red indicator blinks	<ul style="list-style-type: none"> <li>● Quickly save your data and power off your computer. Remove the battery pack and disconnect the AC adaptor, then connect them again. If the problem persists, contact Panasonic Technical Support. The battery pack or charging circuit may be defective.</li> </ul>
The green indicator blinks <sup>*1</sup>	<ul style="list-style-type: none"> <li>● In high temperature mode, the battery is discharging to the level that corresponds to an 80%<sup>*2</sup> charge for normal temperature mode. (☞ <small>Reference Manual</small> “Battery Power”) Do not remove the battery pack while the battery indicator is blinking green. If you remove it, the power will be turned off forcibly.</li> </ul> <p><sup>*1</sup> Only for the main battery pack. <sup>*2</sup> In high temperature mode, the level that corresponds to an 80% charge for normal temperature mode is displayed as [100%].</p>

## ● Battery Indicator (continued)

The battery indicator blinks green and orange alternately	<ul style="list-style-type: none"> <li>● Warming up the system to prevent hard disk drive malfunctions at low temperature. Leave your computer as is. Once the allowable temperature range requirement is satisfied, your computer will start automatically.</li> </ul>
The orange indicator blinks	<ul style="list-style-type: none"> <li>● Battery cannot be recharged temporarily because the internal temperature of the battery pack is outside of the acceptable temperature range for recharging. Once the allowable range requirement is satisfied, charging begins automatically. Your computer can be used normally in this state.</li> </ul>

## ● Touch Pad / Touchscreen (only for models with touchscreen)

The cursor cannot be controlled properly	<ul style="list-style-type: none"> <li>● If you are using an external mouse, ensure that the external mouse has been connected correctly.</li> <li>● Restart the computer by using the keyboard (Press , , and select [Restart] with ).</li> <li>● If the computer does not respond to keyboard commands, read “No response” ( page 32).</li> </ul>
Unable to input using the touch pad	<ul style="list-style-type: none"> <li>● Has the Setup Utility been used to set [Touch Pad] to [Enable]?</li> <li>● When external mouse drivers are installed (e.g., Intellimouse), the touch pad may not be used.</li> <li>● Has the touch pad driver been properly installed?</li> </ul>
Unable to point correctly with the stylus included with the computer	<ul style="list-style-type: none"> <li>● As a result of the physical characteristics of the touchscreen, sometimes the position of the stylus does not match the position of the cursor on the screen. This is not a malfunction. Perform [Calibration] ( page 15).</li> </ul>
Unable to input by touching the display	<ul style="list-style-type: none"> <li>● Has the Setup Utility been used to set [Touchscreen] to [Enable]?</li> <li>● When mouse drivers are installed (i.e. IntelliMouse), the touchscreen is unable to be used. Reinstall the touchscreen driver.</li> <li>● Has the touchscreen driver been properly installed?</li> </ul>

## ● SD Memory Card

Cannot log on with the SD Memory Card	<ul style="list-style-type: none"> <li>● Windows logon user name and password are not set in the SD Memory Card correctly. Enter the Windows user name and password without using the SD Memory Card. After logging on, set the same user name and the password on the SD Memory Card and Windows, using the following operation. <ul style="list-style-type: none"> <li>• Change the setting of the SD Memory Card by [SD Card Setup]. ( Reference Manual “SD Memory Card Security Function”)</li> </ul> </li> </ul>
---------------------------------------	--

## ● Fast User Switching function

Some applications may not work properly	<ul style="list-style-type: none"> <li>● When switching to a different user with the Fast User Switching function, the following problems may occur. <ul style="list-style-type: none"> <li>• Some applications may not work properly.</li> <li>• Key combinations with  may not work.</li> <li>• It may not be possible to set the settings of the display.</li> <li>• A serial mouse may not work.</li> <li>• &lt;Only for models with wireless LAN&gt; Wireless LAN may not work.</li> </ul> </li> </ul> <p>In this case, log off all users without using Fast User Switching function, and try the operation once more. If the problem persists, restart the computer.</p>
---	---

# Dealing with Problems (Summary)

## ● Reference Manual

<p><b>The Reference Manual is not displayed</b></p>	<ul style="list-style-type: none"> <li>● Is Adobe Reader installed? &lt;For localized OS model&gt; If you have uninstalled Adobe Reader, install using the following procedures. Select [start] - [Run], input [c:\util\reader\AdbeRdr70_enu_full_.exe], then select [OK]. Install Adobe Reader by following the instructions on the screen.</li> <li>&lt;For MUI OS model&gt; If Adobe Reader is not installed, install using the following procedures. When installing the program, do not change the installation destination folder. If the destination folder is changed, the Reference Manual cannot be opened from the [start] menu. Select [start] - [Run], input the following, then select [OK]. English: [c:\util\reader\m\AdbeRdr70_enu_full.exe] French: [c:\util\reader\f\AdbeRdr70_fra_full.exe] German: [c:\util\reader\g\AdbeRdr70_deu_full.exe] Italian: [c:\util\reader\t\AdbeRdr70_ita_full.exe] Spanish: [c:\util\reader\p\AdbeRdr70_esp_full.exe] Swedish: [c:\util\reader\s\AdbeRdr70_sve_full.exe] Dutch: [c:\util\reader\nl\AdbeRdr70_nld_full.exe] Finnish: [c:\util\reader\fi\AdbeRdr70_suo_full.exe] Norwegian: [c:\util\reader\no\AdbeRdr70_nor_full.exe] Install Adobe Reader by following the instructions on the screen.</li> </ul>
---	---

## ● Others

<p><b>No response</b></p>	<ul style="list-style-type: none"> <li>● Press <b>Ctrl</b> + <b>Shift</b> + <b>Esc</b> to open Task Manager and close the software application which is not responding.</li> <li>● Is there an input screen hidden behind another window? Use <b>Alt</b> + <b>Tab</b> to check for other windows being displayed.</li> <li>● After shutting down by sliding the power switch for more than four seconds, slide the power switch to power on and open the application again. If the program no longer works normally, delete the program using the following menu. Then reinstall the program. [start] - [Control Panel] - [Add or Remove Programs]</li> </ul>
<p><b>Unable to input password</b></p>	<ul style="list-style-type: none"> <li>● Some keyboards have unusable keys (e.g. the “M” key on French keyboards). When you push the key and the alarm sounds, use the other key.</li> </ul>



# Reinstalling Software

When reinstallation procedure is performed, the contents of the hard disk will be erased. Be sure to back up any critical data on your hard disk to another media or to an external hard disk before running the reinstallation procedure.

The reinstallation procedure will return the computer to its original condition.

Even if a hard disk backup area has been created, this backup area will be erased, and all the backed up data will be lost.

(This is not the case when Windows is reinstalled in the first partition.)

- If you have created partitions for data, the data may be erased or become corrupt as a result of the reinstallation procedure.

## Before Reinstallation

### ● Preparing

- Product Recovery CD-ROM (included)
- Panasonic CD/DVD drive for the multimedia pocket (optional: Confirm the latest information on optional products in catalogs, etc.)

### ● Important

- Before the reinstallation procedure, remove all peripherals (except for the CD/DVD drive).
- Be sure the AC adaptor is connected until the reinstallation procedure is completed.

## Reinstalling

### CAUTION

- When inputting numbers, press the NumLock key, and enter numbers in the ten-key mode.

- 1 Turn off the computer and insert the CD/DVD drive into the multimedia pocket. (☞ Reference “Multimedia Pocket”)
- 2 Turn on the computer, and press **(F2)** while [Panasonic] boot screen is displayed.  
The Setup Utility will start up.  
If the password has been set, enter the Supervisor Password.
- 3 Write down all of the contents of the Setup Utility and then press **(F9)**.  
At the confirmation message, select [Yes] and press **(Enter)**.
- 4 Select [Boot] menu, then select [IDE MP: xxxxxxxxxx] and press **(F6)** until [IDE MP: xxxxxxxxxx] is at the top of the [Boot] menu.
- 5 Place the disc number one of the recovery CDs into the CD/DVD drive.
- 6 Press **(F10)**.  
At the confirmation message, select [Yes] and press **(Enter)**.  
The computer will restart, and this screen should appear.

```
-----
Select a number
-----
1. [ Recovery ] Reinstall Windows.
2. [ Erase HDD ] Erase the whole data on HDD for security.
3. [ Backup   ] Enable the Backup function.*1
-----
0. [ Cancel   ] Cancel.
-----
```

\*1 This is not displayed when the hard disk backup function has been enabled.

<When the hard disk backup function has been enabled>  
When the following message appears, press **(Y)**.

```
-----
Reinstalling : Windows(R) XP Professional
-----
The Backup function has been enabled.
If [ Recovery ] or [ Erase HDD] is executed, the Backup function will be
disabled, and your Backup data will be lost.
(If Windows is reinstalled to the first partition, Backup data will not be
lost.)
Will you continue?
-----
```

- 7 Press **(1)** to execute [1.[Recovery]].  
(You can cancel this operation by pressing **(0)**.)  
The License Agreement screen should appear.
- 8 Press **(1)** to select [1. Yes, I agree to the provisions above and wish to continue!].  
This screen should appear.

```
-----
Select a number
-----
Reinstalling : Windows(R) XP Professional
-----
1. Reinstall Windows to the whole HDD to factory default.
2. Make two partitions, for the operating system and data. And reinstall
   Windows to the operating system partition.
   (All existing partitions on HDD will be lost.)
3. Reinstall Windows to the first partition.
-----
0. Cancel
-----
```

- 9 Make a selection from the menu.

### NOTE

- When [2] is selected, the hard disk backup function cannot be enabled. When using the hard disk backup function, select [1] to reinstall Windows to the hard disk, and then divide the hard disk into partitions when a backup area is created (☞ page 37).

# Reinstalling Software

- When selecting [2], enter the basic partition size for the operating system installation and press **Enter**.  
(The data partition size is the remainder after subtracting the basic partition size.)
- To select [3], the initial partition size must be 6 GB or more of the hard disk size. Reinstallation cannot be performed with a small partition size.

<When the hard disk backup function has been enabled>  
If you select [1] or [2], the following message appears. In this case, press **Y**.

-----  
The Backup function has been enabled.  
If [Recovery] is executed, the Backup function will be disabled, and your Backup data will be lost.  
Will you continue?  
-----

If the following message appears, press **R**.

-----  
Computer must be rebooted in order to execute [Recovery].  
Please reboot with Product Recovery CD-ROM set in the appropriate drive.  
After rebooting, execute [Recovery] following the on screen instructions.  
-----

- 10** At the confirmation message, press **Y**.  
The operation of reinstallation for the hard disk starts automatically. (The operations take about 20 minutes.)

## CAUTION

- Do not interrupt the reinstallation procedure before completion, for example by turning off the computer or pressing **Ctrl** + **Alt** + **Del**, as this may prevent Windows from starting up, or may cause data to be lost so that the reinstallation procedure cannot be executed.
- When a message appears instructing you to insert the next CD, insert the recovery CD showing the next number in the sequence, and then select [OK]. If the message [The media does not contain the correct file] appears, select [OK]. A message will appear instructing you to insert the next CD. Confirm that the proper recovery CD has been inserted, then select [OK].

After the reinstallation procedure completes, this screen should appear.

-----  
[Recovery] is complete.  
Windows(R) XP Professional install wizard will start after reboot.  
Please remove the Product Recovery CD-ROM, and turn off the computer.  
If the reinstall process is interrupted before completion, please execute [Recovery] again.  
-----

- 11** Remove the recovery CD, and then press any key.  
The computer will be shut down.
- 12** Remove the CD/DVD Drive.
- 13** Turn on the computer, and press **F2** while [Panasonic] boot screen is displayed.  
The Setup Utility will start up.  
If the password has been set, enter the Supervisor Password.

- 14** Press **F9**.

At the confirmation message, select [Yes] and press **Enter**. (The Setup Utility settings will return to their default values. Even the security settings with the exception of the password(s) will return to their default values.)

- 15** Select [Exit] and then select [Save Current Values], then press **Enter**.  
At the confirmation message, select [Yes] and press **Enter**.

- 16** Turn the computer off by sliding the power switch.

## NOTE

- If additional instructions are included with the computer, be sure to read them. It may be necessary to perform additional operations during the following procedures.

- 17** Perform the first-time use operation (☞ page 12 step 6 - page 14 step 9).

- 18** Run the Setup Utility and change the settings where necessary.

## <Changing the drive letter>

You can change the drive letter for the CD/DVD drive or hard disk drive by the following steps.

- Drive letters can only be changed when two or more partitions have been created on the hard disk drive. The drive letter of the C drive cannot be changed.
  - We recommend that you make these changes before installing applications.
- 1** Select [start] - [Control Panel] - [Performance and Maintenance] - [Administrative Tools] - [Computer Management].
  - 2** Select [Disk Management] from [Storage].
  - 3** Right click on the partition of the hard disk or the name of the CD/DVD drive and select [Change Drive Letter and Paths...].
  - 4** Select [Change].
  - 5** Select [Assign the following drive letter] and select the new drive letter, and then select [OK].
  - 6** At the confirmation message, select [Yes].

# LIMITED USE LICENSE AGREEMENT

THE SOFTWARE PROGRAM(S) (“PROGRAMS”) FURNISHED WITH THIS PANASONIC® PRODUCT (“PRODUCT”) ARE LICENSED ONLY TO THE END-USER (“YOU”), AND MAY BE USED BY YOU ONLY IN ACCORDANCE WITH THE LICENSE TERMS DESCRIBED BELOW. YOUR USE OF THE PROGRAMS SHALL BE CONCLUSIVELY DEEMED TO CONSTITUTE YOUR ACCEPTANCE OF THE TERMS OF THIS LICENSE.

Matsushita Electric Industrial Co., Ltd. (“MEI”) has developed or otherwise obtained the Programs and hereby licenses their use to you. You assume sole responsibility for the selection of the Product (including the associated Programs) to achieve your intended results, and for the installation, use and results obtained therefrom.

## LICENSE

- A. MEI hereby grants you a personal, non-transferable and non-exclusive right and license to use the Programs in accordance with the terms and conditions stated in this Agreement. You acknowledge that you are receiving only a LIMITED LICENSE TO USE the Programs and related documentation and that you shall obtain no title, ownership nor any other rights in or to the Programs and related documentation nor in or to the algorithms, concepts, designs and ideas represented by or incorporated in the Programs and related documentation, all of which title, ownership and rights shall remain with MEI or its suppliers.
- B. You may use the Programs only on the single Product which was accompanied by the Programs.
- C. You and your employees and agents are required to protect the confidentiality of the Programs. You may not distribute or otherwise make the Programs or related documentation available to any third party, by time-sharing or otherwise, without the prior written consent of MEI.
- D. You may not copy or reproduce, or permit to be copied or reproduced, the Programs or related documentation for any purpose, except that you may make one (1) copy of the Programs for backup purposes only in support of your use of the Programs on the single Product which was accompanied by the Programs. You shall not modify, or attempt to modify, the Programs.
- E. You may transfer the Programs and license them to another party only in connection with your transfer of the single Product which was accompanied by the Programs to such other party. At the time of such a transfer, you must also transfer all copies, whether in printed or machine readable form, of every Program, and the related documentation, to the same party or destroy any such copies not so transferred.
- F. You may not remove any copyright, trademark or other notice or product identification from the Programs and you must reproduce and include any such notice or product identification on any copy of any Program.

YOU MAY NOT REVERSE ASSEMBLE, REVERSE COMPILE, OR MECHANICALLY OR ELECTRONICALLY TRACE THE PROGRAMS, OR ANY COPY THEREOF, IN WHOLE OR IN PART.

YOU MAY NOT USE, COPY, MODIFY, ALTER, OR TRANSFER THE PROGRAMS OR ANY COPY THEREOF, IN WHOLE OR IN PART, EXCEPT AS EXPRESSLY PROVIDED IN THE LICENSE.

IF YOU TRANSFER POSSESSION OF ANY COPY OF ANY PROGRAM TO ANOTHER PARTY, EXCEPT AS PERMITTED IN PARAGRAPH E ABOVE, YOUR LICENSE IS AUTOMATICALLY TERMINATED.

## TERM

This license is effective only for so long as you own or lease the Product, unless earlier terminated. You may terminate this license at any time by destroying, at your expense, the Programs and related documentation together with all copies thereof in any form. This license will also terminate effective immediately upon occurrence of the conditions therefor set forth elsewhere in this Agreement, or if you fail to comply with any term or condition contained herein. Upon any such termination, you agree to destroy, at your expense, the Programs and related documentation together with all copies thereof in any form.

YOU ACKNOWLEDGE THAT YOU HAVE READ THIS AGREEMENT, UNDERSTAND IT AND AGREE TO BE BOUND BY ITS TERMS AND CONDITIONS. YOU FURTHER AGREE THAT IT IS THE COMPLETE AND EXCLUSIVE STATEMENT OF THE AGREEMENT BETWEEN US, WHICH SUPERSEDES ANY PROPOSAL OR PRIOR AGREEMENT, ORAL OR WRITTEN, AND ANY OTHER COMMUNICATIONS BETWEEN US, RELATING TO THE SUBJECT MATTER OF THIS AGREEMENT.

# Contrat de licence d'usage limité

Le(s) logiciel(s) (les "Logiciels") fournis avec ce produit Panasonic® (le "Produit") sont exclusivement concédés en licence à l'utilisateur ultime ("vous"), et ils ne peuvent être utilisés que conformément aux clauses contractuelles ci-dessous. En utilisant les logiciels, vous vous engagez de manière définitive à respecter les termes, clauses et conditions des présentes.

Matsushita Electric Industrial Co., Ltd. ("MEI") a mis au point ou obtenu les Logiciels et vous en concède l'utilisation par les présentes. Vous assumez l'entière responsabilité du choix de ce Produit (y compris des Logiciels associés) pour obtenir les résultats escomptés, ainsi que de l'installation, de l'utilisation et des résultats obtenus.

## Licence

- A. MEI vous octroie par les présentes le droit et la licence personnels, non cessibles et non exclusifs d'utiliser les Logiciels conformément aux termes, clauses et conditions de ce contrat. Vous reconnaissez ne recevoir qu'un droit limité d'utiliser les Logiciels et la documentation les accompagnant et vous vous engagez à n'obtenir aucun droit de titre, propriété ni aucun autre droit vis-à-vis des Logiciels et de la documentation les accompagnant ni vis-à-vis des algorithmes, concepts, dessins, configurations et idées représentés par ou incorporés dans les Logiciels et la documentation les accompagnant, dont les titres, la propriété et les droits resteront tous à MEI ou à leurs propriétaires.
- B. Vous ne pouvez utiliser les Logiciels que sur le Produit unique qui est accompagné par les Logiciels.
- C. Vous et vos employés ou agents êtes requis de protéger la confidentialité des Logiciels. Vous ne pouvez ni distribuer ni mettre les Logiciels et la documentation les accompagnant à la disposition d'un tiers, par partage de temps ou de quelque autre manière que ce soit, sans l'autorisation écrite préalable de MEI.
- D. Vous ne pouvez ni copier ni reproduire ni permettre la copie ni la reproduction des Logiciels ni de la documentation les accompagnant pour quelque fin que ce soit, à l'exception d'une (1) copie des Logiciels à des fins de sauvegarde uniquement pour soutenir votre utilisation des Logiciels sur le Produit unique qui est accompagné par les Logiciels. Vous ne pouvez ni modifier ni tenter de modifier les Logiciels.
- E. Vous ne pouvez céder les Logiciels et en octroyer la licence à une autre partie qu'en rapport avec votre cession du Produit unique qui est accompagné par les Logiciels à cette autre partie. Au moment de cette cession, vous devez céder également toutes les copies, que ce soit sous forme imprimée ou lisible par la machine, de tous les Logiciels ainsi que de la documentation les accompagnant, à la même partie ou détruire les copies non cédées.
- F. Vous ne pouvez retirer aucune marque de droits d'auteur, marque de commerce ou autre ni aucune identification de produit des Logiciels et vous devez reproduire et inclure toutes ces notices ou identifications de produit sur toutes les copies des Logiciels.

Vous ne pouvez assembler en sens inverse, compiler en sens inverse ni retracer les Logiciels ni aucune de leurs copies, de façon électronique ou mécanique, en tout ou en partie.

Vous ne pouvez utiliser, copier, modifier, altérer ni céder les Logiciels ni aucune de leurs copies, en tout ou en partie, à l'exception de ce qui est expressément stipulé dans ce contrat.

Si vous cédez la possession de toute copie ou de tout Logiciel à une autre partie, à l'exception de ce qui est autorisé au paragraphe E ci-dessus, votre licence est automatiquement résiliée.

## Termes, clauses et conditions

Cette licence n'est effective que pour la durée de possession ou de crédit-bail du Produit, à moins d'une résiliation antérieure. Vous pouvez résilier cette licence à tout moment en détruisant, à vos frais, les Logiciels et la documentation les accompagnant avec toutes leurs copies, sous quelque forme que ce soit. Cette licence sera également résiliée, avec application immédiate, si les conditions de résiliation définies ailleurs dans ce contrat se sont réalisées ou si vous ne respectez pas les termes, clauses et conditions qui y sont contenues. Au moment de la résiliation, vous acceptez de détruire, à vos frais, les Logiciels et la documentation les accompagnant avec toutes leurs copies, sous quelque forme que ce soit.

Vous reconnaissez avoir lu ce contrat, en avoir compris toute la substance et avoir accepté de respecter ses termes, clauses et conditions. Vous reconnaissez en outre qu'ils sont la description complète et exclusive du contrat conclu entre nous, contrat qui remplace et annule toute proposition ou contrat précédent, écrit ou oral, et toute autre communication entre nous, relativement à l'objet du présent contrat.

# Hard Disk Backup Function

The hard disk backup function creates a backup area (storage area) on the hard disk. This area is to back up (store) hard disk contents or restore backed up contents to their original locations.

By backing up the data on your hard disk to a backup area, you can protect your data from loss or damage resulting from operational errors or other factors. Also, you can back up or restore hard disk contents using this computer alone, without having to use other media or peripheral devices.

At the time of purchase, the hard disk backup function is disabled. If you follow the procedure below to create a backup area, the hard disk backup function will be enabled, and you will be able to back up your data. Note, that once the backup function has been enabled, you will have to perform the reinstallation procedure to disable it again (☞ page 33).

The hard disk backup function cannot back up or restore data properly if there is a problem with the hard disk when the data is backed up or restored. Note that if an error occurs while data is being restored, whether as a result of an unexpected malfunction, incorrect operation, or other reason, the data in the hard disk (data before restoration) may be lost.

Matsushita Electric Industrial Co., Ltd. will bear no responsibility for any damages suffered by the user (including loss of data) as a result of the use of this function.

## Preparing

- Product Recovery CD-ROM (included)
- Panasonic CD/DVD drive for the multimedia pocket (optional: Confirm the latest information on optional products in catalogs, etc.)

## Before Using a Hard Disk Backup Function

- Disconnect or remove all peripheral devices (except for the CD/DVD drive) and SD Memory Cards, as the backup area may not be created properly while these devices are connected.
- Be sure the AC adaptor is connected to the computer.
- A backup area cannot be created if the hard disk is already divided into several partitions. Return the computer to its condition at the time of purchase (one partition only), and create the backup area.
- To divide the partition, make the selection when the backup area is created (☞ page 38 step 8).
- If the partition configuration is changed (partitions created, size changed, etc.) after the backup area has been created, it will no longer be possible to execute the backup function. To change the configuration, it is necessary to return the computer to its condition at the time of purchase, and then create the backup area again.
- The hard disk backup function will only work for the internal hard disk. This function does not work with an external hard disk.
- Backup and restore functions will not operate if the hard disk has been damaged.
- Do not use the NTFS file system compression function, as this may result in insufficient capacity of the backup area.
- If the hard disk malfunctions, it will be impossible to read the data stored on it. We recommend that you also back up important data to a location other than the hard disk (an external hard disk or other media).
- Execute a disk error check using the following procedure.
  - 1 Select [start] - [My Computer], right-click [Local Disk(C:)], and then select [Properties].
  - 2 Select [Check Now] from [Tools].
  - 3 In [Check Disk], select [Start] without adding a check mark beside any of the items.  
If a message is displayed indicating that there is an error in the disk, display [Check Disk], and add a check mark for [Automatically fix file system errors] and [Scan for and attempt recovery of bad sectors], select [Start], and check for disk errors again.
- The hard disk backup function does not accommodate dynamic disks. Do not convert the hard disk to a dynamic disk.

# Hard Disk Backup Function

## NOTE

- Regarding backup area
  - Requires availability of at least half of the entire hard disk. Without sufficient space available, the backup area cannot be created.
  - When the backup area is created, the usable hard disk capacity will be reduced to less than half.
  - The backup area cannot be accessed from Windows. For this reason, backed up data cannot be copied to CD-R or other removable disk media.
  - When the hard disk backup function is executed, data in the backup area will be overwritten. If newly created or edited data is backed up later, data stored previously in the backup area will be lost.

## Create a Backup Area

### CAUTION

- When inputting numbers, press the NumLock key, and enter numbers in the ten-key mode.

- 1 Turn off the computer and insert the CD/DVD drive into the multimedia pocket. (☞ Reference Manual “Multimedia Pocket”)
- 2 Turn on the computer, and press **(F2)** while [Panasonic] boot screen is displayed. The Setup Utility will start up. If a password has been set, enter the Supervisor Password. You cannot register [Boot] menu with a User Password.
- 3 Select [Boot] menu, then select [IDE MP: xxxxxxxxxx] and press **(F6)** until [IDE MP: xxxxxxxxxx] is at the top of the [Boot] menu.
- 4 Place the disk number one of the recovery CDs into the CD/DVD drive.
- 5 Press **(F10)**. At the confirmation message, select [Yes] and press **(Enter)**. The computer will restart. If [Enter Password] is displayed during the following procedures, input the Supervisor Password or the User Password. This screen should appear.

```
-----  
Select a number  
-----  
1. [ Recovery ] Reinstall Windows.  
2. [ Erase HDD ] Erase the whole data on HDD for security.  
3. [ Backup   ] Enable the Backup function.  
-----  
0. [ Cancel   ] Cancel.  
-----
```

- 6 Press **(3)** to execute [3.Backup].

### CAUTION

- When dividing the hard disk into partitions  
Do not execute [1. Recovery] to divide the hard disk into partitions. The hard disk backup function cannot be enabled after the hard disk has been partitioned. Use procedure 8 to divide the hard disk.

- 7 At the confirmation message, press **(Y)**.
- 8 Select how to divide the hard disk from the menu.  
<To create a backup area and enable the backup function without dividing the hard disk>  
Select [1].

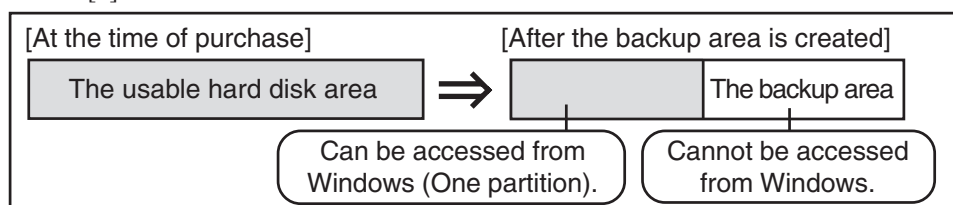

<To create a backup area and divide hard disk into two partitions, for OS and data>  
Select [2], enter the partition size (GB), and press **Enter**.

- You can cancel this operation by pressing **0**.
- The data partition size will be the maximum settable size less the number entered above. The maximum settable size will differ depending on models.

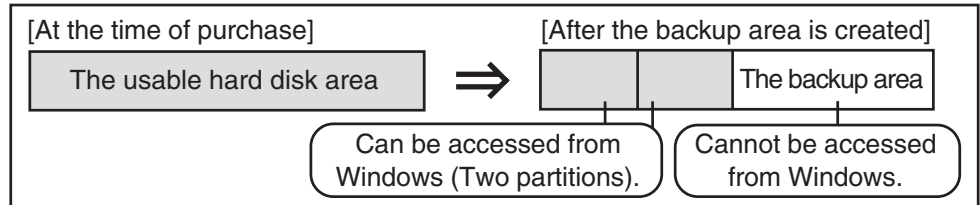

- 9 At the confirmation message, press **Y**.  
The backup area is then created.
- 10 When the message [You must reboot in order to enable the Backup function] appears, remove the recovery CD, and press any key to restart the computer. The computer is restarted, then the backup process will begin.
- 11 When the message [[Backup] is complete] appears, press **Ctrl** + **Alt** + **Del** to restart the computer.

#### CAUTION

- Do not press **Ctrl** + **Alt** + **Del** until the message is displayed.

- 12 After logging on to Windows, a message will appear advising that a new device has been installed and that the computer must be restarted to enable the settings. Select [Yes] to restart the computer.

#### NOTE

- The [Boot] menu in the Setup Utility is set to start up from the CD/DVD drive. Change this setting if necessary.
- The next time the backup or restore functions are executed, follow the procedure for “Backing Up and Restoring Data” (☞ below).

## Backing Up and Restoring Data

#### CAUTION

- Before executing the backup function, execute a disk error check (☞ page 37).
- Do not interrupt the backup or restore functions before completion, for example by turning off the power or pressing **Ctrl** + **Alt** + **Del**, as this may prevent Windows from starting up, or may cause data to be lost so that the backup and restore functions cannot be executed.

- 1 Turn the computer on, and press **F2** while [Panasonic] boot screen is displayed. The Setup Utility will start up.  
If a password has been set, enter the Supervisor Password or the User Password.
- 2 Select [Exit] menu, then select [Hard Disk Backup / Restore] and press **Enter**.  
At the confirmation message, select [Yes] and press **Enter**.

# Hard Disk Backup Function

- 3 Select the operation to be executed from the menu.  
<To back up hard disk contents to the backup area>
  - ① Press **(1)** to execute [1. [Backup]].  
(When dividing the hard disk into two partitions, select the backup method at next screen.)
  - ② At the confirmation message, press **(Y)**.  
The backup process will begin.<To restore backed up contents to the hard disk>
  - ① Press **(2)** to execute [2. [Restore]].  
(When data is backed up in two partitions, select the restore method at next screen.)
  - ② At the confirmation message, press **(Y)**.  
The restore process will begin.

## NOTE

- The time required to complete the backup or restore process differs depending on the data volume.

- 4 When the message [[Backup] is complete] or [[Restore] is complete] is displayed, press **(Ctrl) + (Alt) + (Del)** to restart the computer.
  - If the backup or restore process was interrupted before completion, for example if the power was turned off, execute the process again.
  - After logging on to Windows, when a new device is installed and a message appears advising that the computer must be restarted to enable the settings, select [Yes] to restart the computer.

## CAUTION

- When the hard disk backup function has been enabled, the backed up data will not be erased even if a commercial data erasing utility or similar software is used to erase all data from user-accessible area. To erase all data on the hard disk, including backed up data, use a commercial data erasing utility after disabling the hard disk backup function following the procedure below, or use the hard disk data erase utility included in this computer (☞ page 41).
  - Occasionally, the message [#1805 cannot write image file] will be displayed, and the backup function will be interrupted. If this error occurs, execute the backup function again. After this, if the backup function is completed properly, then there is no problem in the hard disk.
- **To disable the hard disk backup function**  
Perform the reinstallation procedure. All data in the backup area and the hard disk will be erased.  
Conduct steps **1-8** for “Reinstalling Software” (☞ page 33). Select [1] or [2] to execute the reinstallation at the screen for executing the reinstallation.
    - When [1] is selected, the hard disk backup function will be disabled.
    - When [2] is selected, the hard disk backup function will be disabled, but in this case, because the hard disk has been divided into partitions, the hard disk backup function cannot be re-enabled (☞ page 26).



# Hard Disk Data Erase Utility

This computer is equipped with a utility for erasing hard disk data.

When disposing of or transferring ownership of this device, erase all data on the hard disk in order to prevent the theft of hard disk data by following the steps below.

The hard disk data erase utility erases data using an “overwriting” method, but there is a possibility that due to malfunctions or other operational errors, data may not be completely erased. There are also specialized devices that may be able to read data that has been erased using this method. If you need to erase highly confidential data, we recommend that you contact a company that specializes in this process. Matsushita Electric Industrial Co., Ltd. will bear no responsibility for losses or damages suffered as a result of the use of this utility.

## Preparing

- Product Recovery CD-ROM (included)
- Panasonic CD/DVD drive for the multimedia pocket (optional: Confirm the latest information on optional products in catalogs, etc.)

### NOTE

- Be sure the AC adaptor is connected until the procedure is completed.
- This utility can only be used for internal hard disk. It cannot be used to erase data from external hard disks.
- This utility cannot erase data from damaged disk.
- This utility cannot erase data for specific partitions.
- After executing this utility, the computer cannot be booted from the hard disk.
- The backup area and the data in the backup area will be erased.

## Procedure

### CAUTION

- When inputting numbers, press the NumLock key, and enter numbers in the ten-key mode.

- 1 Turn off the computer.
- 2 Insert the CD/DVD drive into the multimedia pocket.  
(☞ Reference “Multimedia Pocket” Manual)
- 3 Turn on the computer, and press **(F2)** while [Panasonic] boot screen is displayed.  
The Setup Utility will start up.  
If the password has been set, enter the Supervisor Password.
- 4 Select [Boot] menu, then select [IDE MP: xxxxxxxxxx] and press **(F6)** until [IDE MP: xxxxxxxxxx] is at the top of the [Boot] menu.
- 5 Place the disc number one of the recovery CDs into the CD/DVD drive.
- 6 Press **(F10)** .  
At the confirmation message, select [Yes] and press **(Enter)** .  
The computer will restart, and this screen should appear.

```
-----  
Select a number  
-----  
1. [ Recovery ] Reinstall Windows.  
2. [ Erase HDD ] Erase the whole data on HDD for security.  
3. [ Backup ] Enable the Backup function.*1  
-----  
0. [ Cancel ] Cancel.  
-----
```

\*1 This is not displayed when the hard disk backup function has been enabled.

<When the hard disk backup function has been enabled>  
When the following message appears, press **(Y)** .

```
-----  
Reinstalling : Windows(R) XP Professional  
-----  
The Backup function has been enabled.  
If [Recovery ] or [Erase HDD] is executed, the Backup function will be  
disabled, and your Backup data will be lost.  
(If Windows is reinstalled to the first partition, Backup data will not be  
lost.)  
Will you continue?  
-----
```

- 7 Press **(2)** to execute [2. [Erase HDD]].  
(You can cancel this operation by pressing **(0)** .)  
<When the hard disk backup function has been enabled>  
When the following message appears, press **(Y)** .

```
-----  
The Backup function has been enabled.  
If [Erase HDD] is executed, the Backup function will be disabled, and your  
Backup data will be lost.  
Will you continue?  
-----
```

When the following message appears, press **(R)** .

```
-----  
Computer must be rebooted in order to execute [Erase HDD].  
Please reboot with Product Recovery CD-ROM set in the appropriate drive.  
After rebooting, execute [Erase HDD] following the on screen instructions.  
-----
```

- 8 At the confirmation message, press **(Y)** .
- 9 When [ <<<<Start Menu>>>> ] is displayed, press **(Enter)** .
- 10 The approximate time required for erasing data will be displayed.  
Press **(Space)** .

# Hard Disk Data Erase Utility

- 11** At the confirmation message, press **Enter** . The operation of erasing the hard disk will start.  
(If necessary, the “hard disk data erase” operation can be cancelled after it has begun by pressing **Ctrl** + **C** . If the operation is cancelled before being completed, a part of data will not be erased.)
- 12** After the operation is complete:  
Under normal conditions, the message [Hard disk data has been deleted.] will be displayed.  
If a problem occurred during the operation, an error message will be displayed.
- 13** Remove the recovery CD, and then press any key to turn off the computer.

# Specifications

This page provides the specifications for the basic model CF-29LTQGZBE/CF-29LTQGZL2/CF-29L3QGZBE/CF-29L3QGZL2. The model number will change depending on the configuration of the unit, such as, CPU speed, memory size, HDD size, Operating System, LCD type, and whether a wireless LAN is built in or not.

- To check the model number:

Check the bottom of the computer or the box the computer came in at the time of purchase.

- To check CPU speed, memory size and the hard disk drive (HDD) size:

Run the Setup Utility (☞ Reference Manual "Setup Utility").

Confirm the required information by checking the following items.

- [Information] menu  
CPU speed: [CPU Speed]      Memory size: [System Memory]      Hard disk drive size: [Primary Master]
- [Advanced] menu  
Wireless LAN: [Wireless LAN] is displayed only if a wireless LAN is built in.

## ● Main Specifications

<b>Model No.</b>		CF-29LTQGZBE/CF-29LTQGZL2	CF-29L3QGZBE/CF-29L3QGZL2
<b>CPU</b>		Intel® Pentium® M Processor Low Voltage 778 (1.60 GHz, 2 MB*1 L2 cache, 400 MHz FSB)	
<b>Memory</b>		512 MB*1 (1536 MB*1 Max.)	
<b>Video Memory</b>		UMA (128 MB*1 Max.)*2	
<b>LCD</b>	<b>Type</b>	13.3 XGA type (TFT) with Touchscreen	13.3 XGA type (TFT)
	<b>Displayed Colors*3</b>	65,536/16,777,216 colors (800 x 600 dots/1024 x 768 dots)	
<b>External Display</b>		65,536/16,777,216 colors (800 x 600 dots/1024 x 768 dots/1280 x 1024 dots/1600 x 1200 dots)*4	
<b>Hard Disk Drive</b>		80 GB*5	
<b>Keyboard</b>		88 keys	
<b>Floppy Disk Drive</b>		720 KB/1.44 MB (two-mode)	
<b>PC Card Slot</b>		Two Type I or Type II, or one Type III	
	<b>Allowable current (total for two slots)</b>	3.3 V: 400 mA 5 V: 400 mA	
<b>RAM Module Slot*6</b>		200 pin, 1.8 V, SO-DIMM, DDR2 SDRAM, PC2-3200 Compliant	
<b>SD Memory Card Slot*7</b>		SD Memory Card	
<b>Interface</b>	<b>Parallel Port</b>	Dsub 25-pin female	
	<b>External Display Port</b>	Mini Dsub 15-pin female	
	<b>Serial Port</b>	Dsub 9-pin male	
	<b>Microphone Jack*8</b>	Miniature jack, 3.5 DIA	
	<b>Headphone Jack</b>	Miniature jack, 3.5 DIA, Impedance 32 Ω, Output Power 4 mW x 2	
	<b>Expansion Bus Connector</b>	Dedicated 80-pin female	
	<b>USB Port</b>	4-pin x 2, USB 2.0	
	<b>Modem</b>	RJ-11 jack, Data: 56 kbps (V.92 & K56flex*9) FAX: 14.4 kbps	
	<b>LAN</b>	RJ-45 jack, IEEE 802.3 10Base-T, IEEE 802.3u 100Base-TX, IEEE 802.3ab 1000Base-T	
	<b>Wireless LAN</b>	Built-in Intel® PRO/Wireless 2915 ABG (☞ page 44)	
	<b>External Antenna Connector</b>	Dedicated 50 Ω coaxial connector	
<b>Pointing Device</b>		Touch Pad Touchscreen (Anti-Reflection, Stylus (included) touch capable)	Touch Pad
<b>Sound</b>		WAVE and MIDI playback, Monaural Speaker (built in)	

\*1 1 MB = 1,048,576 bytes

\*2 A segment of the main memory is allotted automatically depending on the computer's operating status. The size of the Video Memory cannot be set by the user.

\*3 A 16,777,216 color display is achieved by using the dithering function.

\*4 Maximum resolution depends on the specifications of the external display.

\*5 1GB = 1,000,000,000 bytes. Your operating system or some application software will report as fewer GB.

\*6 Only a RAM module designed for PC2-3200 can be added.

\*7 This slot does not support the MultiMedia card.

Operation has been confirmed for Panasonic SD Memory Cards with up to 1 GB capacity.

\*8 Use only a monaural condenser microphone.

\*9 The settings for the K56flex modem need to be changed according to the AT command.

# Specifications

## Main Specifications

<b>Model No.</b>		CF-29LTQGZBE/CF-29LTQGZL2	CF-29L3QGZBE/CF-29L3QGZL2
<b>Battery Pack</b>		Li-ion 11.1 V, 7.65 Ah	
	<b>Operating Time<sup>*10</sup></b>		Main battery: Approx. 5 hours - 8 hours <sup>*11</sup> (Approx. 7 hours <sup>*12</sup> ) Main battery + Second battery: Approx. 8 hours - 13.5 hours <sup>*11</sup> (Approx. 10.5 hours <sup>*12</sup> )
	<b>Charging Time<sup>*10</sup></b>	<b>Power On</b>	Main battery: Approx. 8 hours Main battery + Second battery: Approx. 12 hours
		<b>Power Off</b>	Main battery: Approx. 4.5 hours Main battery + Second battery: Approx. 7 hours
<b>Clock Battery</b>		Coin type lithium battery 3.0 V	
<b>AC Adaptor<sup>*13</sup></b>	<b>Input</b>	100 V - 240 V AC, 50 Hz/60 Hz	
	<b>Output</b>	15.6 V DC, 5.0 A	
<b>Power Consumption<sup>*14</sup></b>		Approx. 35 W <sup>*15</sup> / Approx. 60 W (maximum when recharging in the ON state)	
<b>Environment</b>	<b>Operation</b>	<b>Temperature</b>	5 °C to 35°C {41 °F to 95 °F}
		<b>Humidity</b>	30% to 80% RH (No condensation)
	<b>Storage</b>	<b>Temperature</b>	-20 °C to 60 °C {-4 °F to 140 °F}
		<b>Humidity</b>	30% to 90% RH (No condensation)
<b>Physical Dimensions (W x H x D)</b>		302 mm x 64.3 mm x 273 mm (excluding protrusion) {11.9 " x 2.6 " x 10.7 "}	
<b>Weight (including the carrying handle)</b>		Approx. 3.69 kg {Approx. 8.14 lb.}	Approx. 3.56 kg {Approx. 7.85 lb.}

<sup>\*10</sup> Varies depending on the usage conditions, CPU speed, etc.

<sup>\*11</sup> Measured using BatteryMark™ Version 4.0.1 (LCD brightness: Maximum - Minimum)

<sup>\*12</sup> Measured using MobileMark™ 2002 (LCD brightness: 60 cd/m<sup>2</sup>)

<sup>\*13</sup> <Only for North America>

The AC adaptor is compatible with power sources up to 240 V AC adaptor. The computer is supplied with a 125 V AC compatible AC cord.

<sup>\*14</sup> Approx. 0.9 W when the battery pack is fully charged (or not being charged) and the computer is off.

Approx. 1.5 W when the Wake up from LAN function has been enabled.

<sup>\*15</sup> Rated power consumption

## Wireless LAN

<b>Data Transfer Rates<sup>*16</sup></b>	IEEE802.11a: 54/48/36/24/18/12/9/6 Mbps (automatically switched)
	IEEE802.11b: 11/5.5/2/1 Mbps (automatically switched)
	IEEE802.11g: 54/48/36/24/18/12/9/6 Mbps (automatically switched)
<b>Standards Supported</b>	IEEE802.11a/IEEE802.11b/IEEE802.11g
<b>Transmission Method</b>	OFDM system, DS-SS system
<b>Wireless Channels Used</b>	IEEE802.11a: Channels 36 to 64, 100 to 140
	IEEE802.11b/IEEE802.11g: Channels 1 to 13
<b>RF Frequency Band</b>	IEEE802.11a: 5.18~5.32 GHz, 5.50~5.70 GHz
	IEEE802.11b/IEEE802.11g: 2412~2472 MHz

<sup>\*16</sup> These are speeds specified in IEEE802.11a+b+g standards. Actual speeds may differ.

## Software

<b>Operating System</b>	Microsoft® Windows® XP Professional Service Pack 2 with Advanced Security Technologies	
<b>Utility Programs</b>	Setup Utility	Hard Disk Data Erase Utility <sup>*18</sup>
	DMI Viewer	SD Utility
	Microsoft® Windows® Media Player 10	Icon Enlarger
	Adobe Reader	Loupe Utility
	Intel® PROSet/Wireless Software <sup>*17</sup>	Hotkey Settings
	Panasonic Hand Writing	Battery Recalibration Utility
	PC Information Viewer	Wireless LAN Switch
	Hard Disk Backup Utility <sup>*18</sup>	Wireless Switch Utility

<sup>\*17</sup> Only for models with wireless LAN

<sup>\*18</sup> The Product Recovery CD-ROM is required.

# Memo

# Memo





As an ENERGY STAR® Partner, Matsushita Electric Industrial Co., Ltd. has determined that this product meets the ENERGY STAR® guidelines for energy efficiency.

**Outline of the International ENERGY STAR® Office Equipment Program**

The international ENERGY STAR® Office Equipment Program is an international program that promotes energy saving through the use of computers and other office equipment. The program backs the development and dissemination of products with functions that effectively reduce energy consumption. It is an open system in which business proprietors can participate voluntarily. The targeted products are office equipment such as computers, displays, printers, facsimiles, and copiers. Their standards and logos are uniform among participating nations.

