

HGT 835

Handheld Control Panel

Operating Manual

Publisher: SIGMATEK GmbH & Co KG
A-5112 Lamprechtshausen
Tel.: +43/6274/4321
Fax: +43/6274/4321-18
Email: office@sigmatek.at
WWW.SIGMATEK-AUTOMATION.COM

Copyright © 2014
SIGMATEK GmbH & Co KG

Translation from German

All rights reserved. No part of this work may be reproduced, edited using an electronic system, duplicated or distributed in any form (print, photocopy, microfilm or in any other process) without the express permission.

We reserve the right to make changes in the content without notice. The SIGMATEK GmbH & Co KG is not responsible for technical or printing errors in the handbook and assumes no responsibility for damages that occur through use of this handbook.

8.4" Handheld Control Panel

HGT 835

The HGT 835 Control Panel is an intelligent handheld control panel used for programming and visualization of automated processes. Process diagnosis, operating and monitoring functions are thereby simplified.

A touch screen serves as the input medium for process data and parameters. The output is shown on an 8.4" SVGA TFT color display.

With the LSE mask editor, graphics can be created on the PC, then stored and displayed on the handheld control panel.

The available interfaces can be used to exchange process data or configure the handheld control panel. On the Flash card, the operating system, application and application data are stored.



Contents

1	Essential Components	4
2	Basic Safety Guidelines	5
2.1	Symbols Used	5
2.2	General Safety Guidelines	7
2.3	Designated Use	8
2.4	Residual Risks	11
2.5	Safety of the Machine or Equipment	12
2.6	Conformity with EU Standards	12
2.8	Safety-relevant Parameters	13
3	Technical Data	14
3.1	Performance Data	14
3.2	Electrical Requirements	15
3.3	Terminal	16
3.4	Environmental Conditions	16
3.5	Display	17
3.6	Terminal Requirements	17
3.7	Miscellaneous	17
4	Mechanical Dimensions	18
4.1	Wall Mounting	18
5	Interfaces	19
5.1	Rear Connectors	19

5.2	Key Switch	21
5.3	Confirmation Switch	22
5.4	Emergency Stop.....	23
6	Storage Media.....	24
7	Wiring Guidelines.....	24
7.1	ESD Protection.....	24
8	USB Interface Connections	24
9	Accessory Wall-Mount.....	25
10	Cleaning the Touch Screen	26
11	Recommended Cable Shielding.....	27
11.1	Connection from the Control Cabinet to the HGT	27

1 Essential Components

- 8.4" SVGA TFT color display with background lighting
- 8.4" Touch screen
- Confirmation switch (mounted on the rear side), 2-channel configuration
- Key switch (mounted top-center), two channel wiring.
- Emergency Stop switch (mounted top center), 2-channel
- USB socket with cover
- M16 connector with special cable (swivels 90°)
- Applicable Safety controls:
 - SCP XXX

2 Basic Safety Guidelines

2.1 Symbols Used

For warning, danger messages and informational notes, the following symbols are used in the operator documentation:

DANGER



DANGER

Identifies an immediate danger with high risk, which can lead to immediate death or serious injury if not avoided.

Indique un danger direct à haut risque d'un décès immédiat ou des blessures graves si les consignes de sécurité ne sont pas respectées.

WARNING



WARNING

Identifies a possible danger with a mid-level risk, which **can** lead to death or (serious) injury if not avoided.

Indique un danger possible d'un risque moyen de décès ou de (graves) blessures si les consignes de sécurité ne sont pas respectées.

CAUTION



CAUTION

Identifies a low risk danger, which can lead to injury or property damage if not avoided.

Indique un danger avec un niveau de risque faible des blessures légères ou des dommages matériels si les consignes de sécurité ne sont pas respectées.



Danger for ESD-sensitive components

Les signes de danger pour les composants sensibles aux décharges électrostatiques



This symbol identifies important or additional information regarding the operation of the safety modules.

Ce symbole indique des informations importantes ou supplémentaires concernant le fonctionnement des modules de sécurité particuliers.



INFORMATION

Provides user tips, informs of special features and identifies especially important information in the text.

2.2 General Safety Guidelines

According to the EU guideline 2006/42/EG, the operating instructions are a component of a product.

This handbook must therefore be accessible in the vicinity of the machine, since it contains important instructions.

The technical documentation should be included in the sale, rental or transfer of the product.



Please read the corresponding data sheets and operating instructions thoroughly before handling Safety modules. SIGMATEK is not liable for damages caused through non-compliance with these instructions or respective regulations.

The general and special safety instructions described in the following sections, as well as technical regulations, must therefore be observed.

Subject to technical changes, which improve the performance of the devices. The following documentation represents a series of product descriptions and does not serve to guarantee properties under the warranty.

In regard to the requirements for Safety and health connected to the use of machines, the manufacturer must perform a risk assessment in accordance with machine guidelines 2006/42/EG before bringing a machine to the market.

2.3 Designated Use

The Safety functions implemented in the Safety modules are designed for use with safety-related applications in a PLC control and meet the required conditions for safe operation in SIL 3 or SIL CL 3 according to EN 62061 and in compliance with PL e. Cat. 4 in accordance with EN ISO 13849-1.

A minimum safety-related system can, for example, be implemented with a CSCP 011/012 module. To operate CSDI and/or CSTO modules however, a CSCP module is required.



The instructions contained in this document must be followed.

Safety functions can only be powered by supplies that meet the requirements for PELV in compliance with EN60204.

For error-free operation, proper transport and storage are essential.

Installation, mounting, programming, initial start-up, operation, maintenance and discarding of the Safety module can only be performed **by qualified personnel**.

Qualified personnel in this context are people who have completed training or have trained under supervision of qualified personnel and have been authorized to operate and maintain safety-related equipment, systems and facilities in compliance with the strict guidelines and standards of safety technology. The applicable environmental conditions must be maintained.

Les instructions de cette documentation doivent être respectées.

Les composants de sécurité ne doivent être alimentés que par des alimentations conformes aux exigences PELV selon la norme EN60204.

Un transport et un stockage approprié sont essentiels au bon fonctionnement.

L'installation, le montage, la programmation, la mise en service, l'exploitation, la maintenance et la mise hors service des modules de sécurité **ne doivent être effectués que par du personnel qualifié**.

En ce sens, les personnes qualifiées sont des personnes ayant acquis la formation respective ou étant formées par un spécialiste pour superviser des dispositifs, systèmes et systèmes de sécurité conformément aux directives et normes de sécurité applicables. Les conditions environnementales applicables doivent être respectées.

For your own safety and the safety of others, the safety modules should be used for their designated purpose only.

Correct EMC installation is also included under designated use.

Utilisez les modules de sécurité pour votre sécurité et celle des autres uniquement d'une façon appropriée.

Une utilisation appropriée inclut également une installation conforme à la compatibilité électromagnétique.

Non-designated use consists of

Any changes made to the Safety modules or the use of damaged modules.

The use of the Safety modules outside of technical margins described in these operating instructions.

The use of the Safety modules outside of the technical data described in these operating instructions (see the "Technical data" sections of the respective product documentation).

Sont considérés comme inappropriés

Toute modification de quelque nature que ce soit faite aux modules de sécurité ou l'utilisation de modules de sécurité endommagés.

L'utilisation de modules de sécurité en dehors du cadre technique décrit dans ce manuel

L'utilisation des modules de sécurité en dehors des données techniques décrites dans ce mode d'emploi (voir également les sections « Caractéristiques techniques » dans la documentation correspondante).



In addition, the Safety Guidelines in the other sections of these instructions must be observed. These instructions are visibly emphasized by symbols.

Veillez à bien respecter les consignes de sécurité dans les autres sections de ce manuel. Ces notes sont visuellement mises en évidence par des symboles.

Regarding electrical safety, the requirements of the EN 61131-2 standard apply. For the machine and the entire installation, further norms and guidelines apply. For example, the EN 60204-1

For your own safety and that of others, compliance with the environmental conditions is essential.

The control cabinet and the module carrier must be connected to earth correctly.

For maintenance and repairs, disconnect the system from the power supply.

En ce qui concerne la sécurité électrique, les exigences de la norme EN 61131-2 pour l'unité de commande portative s'appliquent. La machine et l'ensemble de l'installation peuvent être soumises à d'autres normes et réglementations, telles que la norme EN 60204-1.

Pour votre propre sécurité et pour la sécurité des autres, assurez-vous du respect des conditions environnementales.

L'armoire de commande et le support de modules doivent avoir un contact de mise à la terre correct.

Débranchez toujours le système du secteur lors de l'entretien et des réparations.

2.4 Residual Risks



In the risk assessment defined by the 2006/42/EG guideline (machine guideline), the machine manufacturer must include the possible residual risks posed by Safety modules. These include:

Unwanted movements of driven machine components

Unwanted temperatures, emissions of gas, particles, smell and light.

Dangerous contact voltages

The effects of electrical, magnetic and electromagnetic fields produced during operation (for example, on pacemakers and implants)

Possible effects of information technology devices (cell/smart phones etc.)

Release of non-environmentally compatible substances and emissions

Dans l'évaluation des risques définis par la Directive Machines 2006/42/CE le fabricant de la machine doit inclure les éventuels risques résiduels posés par les modules Safety. Ceux-ci comprennent:

Mouvements involontaires des pièces entraînées de la machine.

Températures non désirées, les émissions de gaz, les particules, l'odeur et la lumière.

Tensions de contact dangereuses

Les effets des champs électriques, magnétiques et électromagnétiques produites pendant le fonctionnement (par exemple, sur les stimulateurs cardiaques et les implants).

Les effets possibles sur les dispositifs de technologie de l'information (téléphones cellulaires / téléphones intelligents, etc.)

Dégagement de substances et d'émissions non respectueux de l'environnement.

2.5 Safety of the Machine or Equipment

Strict compliance with the safety guidelines is required, otherwise all warranties and claims are invalid:



Observe all on-site rules and regulations for accident prevention and occupational safety.

2.6 Conformity with EU Standards

The components were constructed in compliance with the following European Union guidelines:

2006/42/EG	Machine guideline
2014/35/EU	Low-voltage guideline
2014/30/EU	EMV guideline
2011/65/EU	RoHS guideline

2.7 Functional Safety Standards

Emergency stop switch und confirmation switch:

- EN 62061 SIL 3 or SIL CL 3
- EN ISO 13849-1/-2 PL e / CAT 4

2.8 Safety-relevant Parameters

The use of the specified parameters requires a risk analysis of the end application.

Input module	Safety parameters (*)
HGT 835 included Safe CPU (SCP XXX)	$PFH_D = 1.07E-11$ (1/h) $MTTF_D = 306$ years $DC = 99.9\%$
Confirmation switch	$B_{10D} = 100,000$
Key switch	$B_{10D} = 10,000$
Emergency stop switch	$B_{10D} = 325,000$

(*) Depending on the application, the probability of failure must be determined for the included electromechanical components based on the B_{10D} values listed here and included in the calculation for the entire system.

3 Technical Data

3.1 Performance Data

Processor	EDGE2 Technology
Processor core	2
Internal cache	32-kbyte L1 Instruction Cache 32-kbyte L1 Data Cache 512-kbyte L2 Cache
Internal program and data memory (DDR3 RAM)	256-Mbyte
Internal remnant data memory	128-kbyte MRAM
Internal storage device	1024-Mbyte microSD card
Internal I/O	no
Interfaces	1x Ethernet 1x USB 2.0 Type A 1x Safety Interface ⁽¹⁾ 1x VARAN
Internal interface connections and devices	1x TFT LCD color display 1x touch
Control panel	touch screen (analog resistive, 4-wire) confirmation switch (2 normally open, 3-stage) key switch (2 normally open) emergency stop switch (2 normally closed)
Display Resolution	8.4" TFT color display 800 x 600 Pixel
Signal generator	no
Real-time clock	yes (buffering approximately 10 days)
Cooling	passive (fanless)

(1) The Safety Interface must be used exclusively with the SIGMATEK SCP XXX! The status of the safety-related inputs (confirmation switch, key switch, emergency stop switch) is sent to the SCP XXX.

(1) L'interface de sécurité doit uniquement être utilisée avec le SIGMATEK SCP XXX! L'état des entrées de sécurité (interrupteur de validation, interrupteur à clé, interrupteur d'arrêt d'urgence) est transmis au SCP XXX.

The function of the key switch, confirmation switch and emergency stop switch must be tested at least once per month.

L'interrupteur à clé, l'interrupteur de confirmation et de l'interrupteur d'arrêt d'urgence doivent être vérifiés au moins une fois par mois!

3.2 Electrical Requirements

Supply voltage	typically +24 V DC (PELV)	
	minimum +24 V DC (PELV)	maximum +30 V DC (PELV)
Supply voltage (UL)	+24-30 V DC (NEC Class 2 or LVLC)	
Protection class	3	
Current consumption Power supply +24 V	typically 0.35 A (without externally connected devices)	typically 0.45 A (with external devices connected)
Inrush current	maximum 10 A for < 50 μ s	
USB current load	maximum 0.5 A	

For USA and Canada:

The supply must be limited to:

- a) max. 5 A at voltages from 0-20 V (0-28.3 Vp) or
- b) 100 VA at voltages from 20-30 V (28.3-42.4 Vp)

The limiting component (e.g. transformer, power supply or fuse) must be certified by an NRTL (Nationally Recognized Testing Laboratory).

Pour les États-Unis et le Canada:

L'alimentation doit être limitée à :

- a) max. 5 A pour des tensions de 0-20 V (0-28,3 Vp), ou
- b) 100 VA pour des tensions de 20-30 V (28,3-42,4 Vp)

Le composant imposant la limite (par exemple, transformateur, alimentation électrique ou fusible) doit être certifié par un NRTL (National Recognized Testing Laboratory, par exemple, UL).

3.3 Terminal

Dimensions	217.4 x 187.7 X 72 mm (W x H x D) (without Emergency Stop switch / key switch)
Material	housing: PC/ASA color: RAL7024
Weight	typically, circa 0.95 kg without connector cable

3.4 Environmental Conditions

Storage temperature	-10 ... +60 °C	
Environmental temperature	0 ... +50 °C	
Operating conditions	pollution degree 2 altitude up to 2000 m	
Humidity	10-90 %, non-condensing	
EMC stability	EN 61000-6-2 (industrial area) (increased requirements according to IEC/EN 62061)	
Shock resistance	EN 60068-2-27	150 m/s ²
Vibration tolerance	10 m/s ²	
Protection Type	EN 60529	IP54 (only with all protective caps fitted)
Free fall (without packaging)	DIN EN 60068-2-32	500 mm

3.5 Display

Type	8.4" TFT LCD color display
Resolution	SVGA 800 x 600 Pixel
Color depth	18-bit RGB (262K colors)
LCD mode	TN / normal white
LCD Polarizer	transmissive
Pixel size	0.213 x 0.213 mm
Active surface	170.40 x 127.80 mm
Backlighting	LED
Contrast	typically 600: 1
Brightness	typically 250 cd/m ²
Angle CR ≥ 10	left and right 75, above 70° and below 60°

3.6 Terminal Requirements

Connection technology	M16 plug (see X2 on page 20)
	special connector cable
	minimum bend radius: 147 mm

3.7 Miscellaneous

Article number	01-245-835
Hardware version	1.x
Connector cable	optionally available (see documentation for connection cables for operating devices)
Standard	UL 508 (E247993)
Approvals	CE, TÜV EC type tested, „ULus

4 Mechanical Dimensions

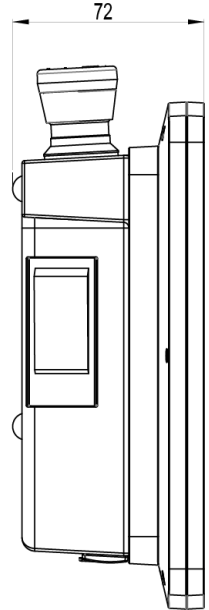
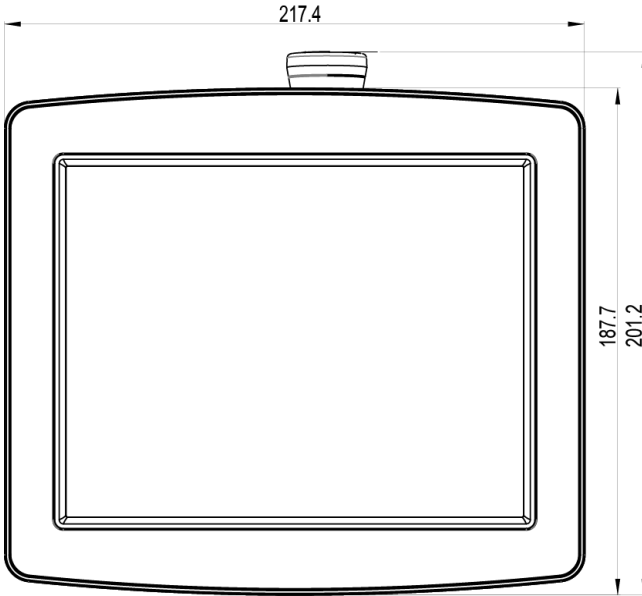

4.1 Wall Mounting

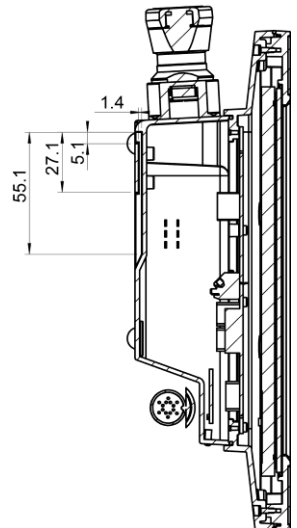
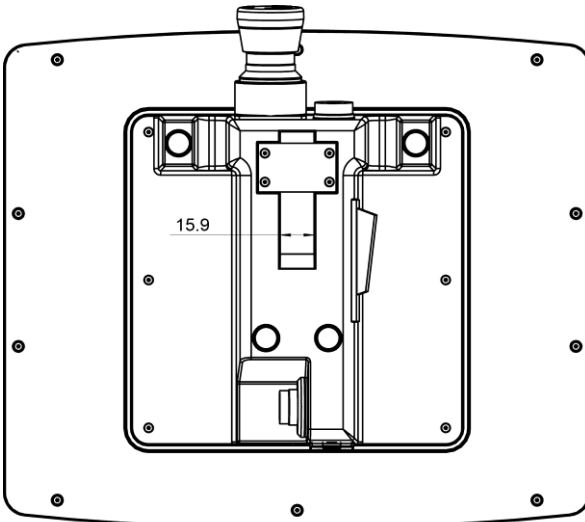

5 Interfaces

5.1 Rear Connectors



X1: USB Interface 2.0 Type A

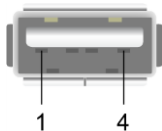

Pin	Function
1	+5 V
2	D-
3	D+
4	GND

It should be noted that many of the USB devices on the market do not comply with USB specifications; this can lead to device malfunctions. It is also possible that these devices will not be detected at the USB port or function correctly. Therefore, it is recommended that every USB stick be tested before actual use.

X2: M16 Cable Connector

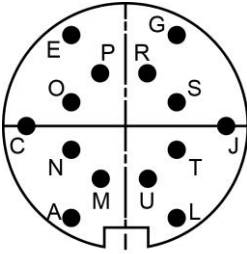

Pin	Wire color	Function
L	Yellow	Safety Interface-H
J	Green	Safety Interface-L
G	Black	Safety Interface shield
E	Red	+24 V DC
C	Black	GND
A	Shield	ETH shield
U	White	ETH_TX+
T	Red	VAR_RX+
S	Blue	VAR_RX-
R	Pink	VAR_TX+
P	Gray	VAR_TX-
O	Yellow	ETH_RX-
N	Green	ETH_RX+
M	Brown	ETH_TX-

**The appropriate connector cables are optionally available.
See documentation for connection cables operating devices.**



The handheld control panel can only be operated with the SCP XXX Safety module!

As required by EN ISO 13850, section 4.1 and EN 60204-1, section 10.7.1, it must be impossible to confuse a functioning handheld control panel with a non-functioning one.

Note on the Emergency Stop function: A non-connected HGT 835 does not have to be visibly sealed!

LED

LED status	Meaning
LED lights green	DC OK

5.2 Key Switch

The key switch is two-stage and read via the SCP XXX connected to the Safety Interface. In the SCP XXX the "HBG0811_K" module is used; inputs 5 and 6 are assigned to the key switch.



5.3 Confirmation Switch

The confirmation switch is three-stage. If the switch is not pressed or pressed only partially, it is inactive. The switch is active when simply pressed (middle stage). In the SCP XXX the "HBG0811_K" module is used; inputs 1 and 2 are assigned to the confirmation switch.

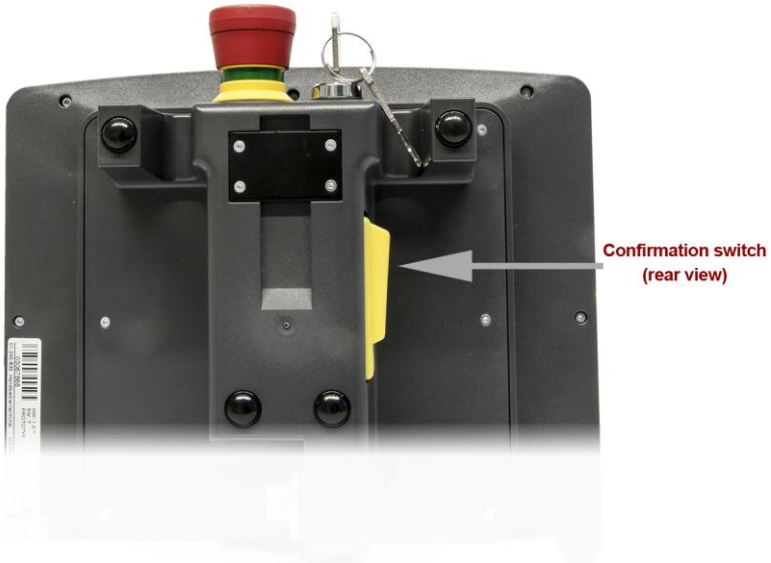

With the "HGT0835" hardware class, it is possible among other things, to evaluate the Safety number of the connected SCP XXX.

5.4 Emergency Stop

The Emergency Stop is two-stage. In the SCP XXX the "HBG0811_K" module is with the inputs 3 and 4.

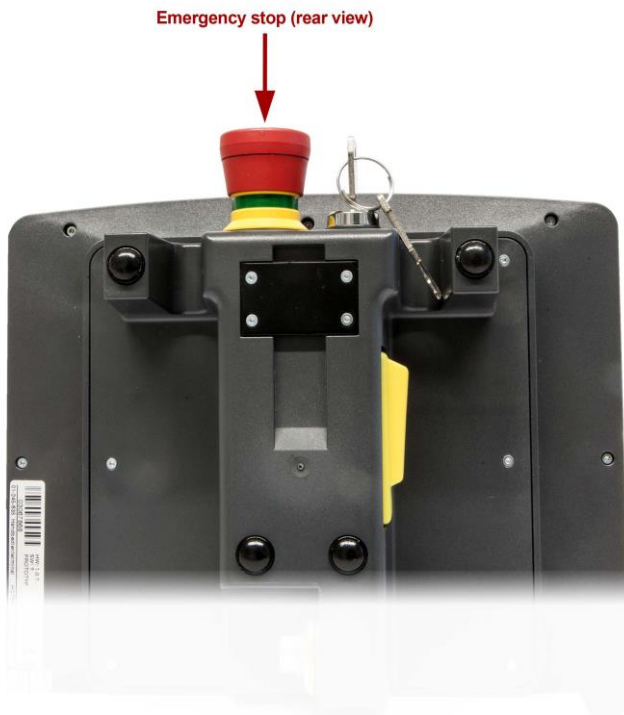

6 Storage Media

It is recommended that only storage media provided by SIGMATEK (CompactFlash cards, microSD cards etc.) be used. The number of read and write actions have a significant influence on the lifespan of the storage media.

The microSD card is not meant to be used as a removable media and thus only should be removed from the card holder for maintenance purposes.

7 Wiring Guidelines

7.1 ESD Protection

Typically, USB devices (keyboard, mouse...) are not equipped with shielded cables. These devices are disrupted by ESD and in some instances, no longer function.

Before any device is connected to, or disconnected from the handheld control panel, the potential should be equalized (by touching the control cabinet or earth terminal). This will allow the dissipation of electrostatic loads (caused by clothing/shoes).

8 USB Interface Connections

The handheld control panel has a USB interface. The terminal has a USB interface connection that can be used to connect various USB devices (keyboard, mouse, storage media, hubs, etc.).

9 Accessory Wall-Mount



The corresponding wall-mount is available from SIGMATEK under the article number 01-245-835-Z5.

10 Cleaning the Touch Screen

CAUTION!

Before cleaning the touch screen, the HGT must be turned off in order to prevent triggering functions or commands unintentionally!

The HGT touch screen can only be cleaned using a soft damp cloth. To dampen the cloth, a screen cleaning solution such as antistatic foam cleaner, water with detergent or alcohol is recommended. To avoid fluids/cleaning solutions from getting into the housing, the HGT should not be sprayed directly. For cleaning, no erosive cleaning solutions, chemicals, abrasive cleansers or hard objects that can scratch or damage the touch screen may be used.

If the HBT is contaminated with toxic or erosive chemicals, it must be carefully cleaned as quickly as possible to prevent acid burns!

To ensure the optimal function of the HGT, the touch screen should be cleaned in regular intervals!

To avoid damaging the touch screen, using either the fingers or a stylus to operate the panel is recommended.

11 Recommended Cable Shielding

For applications in which the bus is operated outside the control cabinet, the correct shielding is required. Especially when for structural reasons, the bus line must be placed next to sources of strong electromagnetic interference. It is recommended that wiring the connector cable in parallel with power cables be avoided whenever possible.

11.1 Connection from the Control Cabinet to the HGT

It is recommended that the shielding be mounted at the entry point of the control cabinet housing. Noise can then be deflected from the electronic components before reaching the module.

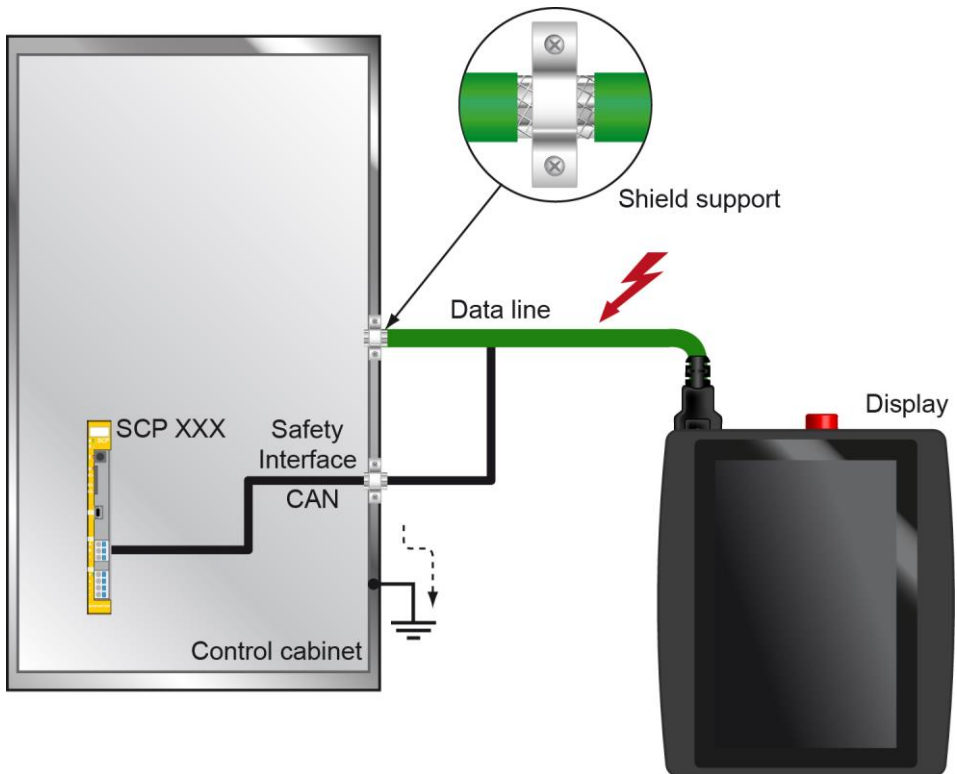

Documentation Changes

Change date	Affected page(s)	Chapter	Note
29.09.2014	12 14	3.2 Electrical Requirements 3.7 Miscellaneous	Added Supply Voltage (UL) and notice in grey box Added Standard
29.12.2014	15	4.1 Wall Mounting	Added Wall Mounting
09.03.2015	23	9 Accessory Wall-Mount	Added Accessory Wall-Mount
12.03.2015	12 5	3.2 Electrical Requirements 2.1 Symbols Used	Changed Supply voltage (UL) Safety Guidelines format
24.03.2015	19-20 15 15	5.2 Connector Cable Layout 3.6 Terminal Requirements 3.7 Miscellaneous	Added Connector Cable Layout Added special connector cable Added connector cable
07.09.2015			Changed SCP to general SCP
29.09.2015	13	3.2 Electrical Requirements	Added LVLC at Supply voltage (UL) line of the table
05.10.2015	15	3.7 Miscellaneous	UL, cUL, CE added
19.04.2016	1	3.1 Performance Data	Table updated
27.06.2016			CAN -> Safety Interface
15.09.2016	24	6 Storage Media	Note microSD added
08.02.2017	19	5.2 Connector Cable Layout	Graphic article number
26.09.2017	15 19	3.5 Terminal Requirements 3.6 Miscellaneous 5.2 Connector Cable Layout	Added cable specifications Added article numbers Length detail removed, replaced picture
08.03.2018	11 15	Document 2.8 Safety-relevant Parameters 3.6 Terminal Requirements 3.7 Miscellaneous 5.2 Connector Cable Layout	Changes due to safety recertification Emergency Stop switch changed Connection technology Connector cable deleted
16.08.2018	14	3.1 Performance Data	Note corrected
17.12.2019		11.1 Connection from the Control Cabinet	Graphics extended

08.09.2020	15	3.2 Electrical Requirements	Protection class added
	16	3.4 Environmental Conditions	Added for Protection Type (only with all protective caps fitted)
30.09.2020	25	9 Accessory Wall-Mount	Article number changed