

ETT 312

Build-In Touch Terminal

Publisher: SIGMATEK GmbH & Co KG
A-5112 Lamprechtshausen
Tel.: 06274/4321
Fax: 06274/4321-18
Email: office@sigmatek.at
WWW.SIGMATEK-AUTOMATION.COM

Copyright © 2016
SIGMATEK GmbH & Co KG

Translation from German

All rights reserved. No part of this work may be reproduced, edited using an electronic system, duplicated or distributed in any form (print, photocopy, microfilm or in any other process) without the express permission.

We reserve the right to make changes in the content without notice. The SIGMATEK GmbH & Co KG is not responsible for technical or printing errors in the handbook and assumes no responsibility for damages that occur through use of this handbook.

Build-In Touch Terminal**ETT 312**

- 3.5" color display with resistive touch
- CAN bus and +24 V supply
- Metal front with 1 color front foil



Contents

1	Technical Data	4
1.1	Performance Data	4
1.2	Electrical Requirements	4
1.3	Controller	4
1.4	Display	5
1.5	Terminal	5
1.6	Environmental Conditions	6
1.7	Miscellaneous	6
2	Mechanical Dimensions	7
3	Connector Layout	8
3.1	Ground connection	9
3.2	Applicable Connectors	9
4	Mounting Instructions	10
4.1	Vertical Mounting Position	10
5	CAN Bus Protocol	11
6	CAN Bus Setup	11
6.1	CAN Bus Station Number	11
6.2	CAN Bus Data Transfer Rate	11
7	CAN Bus Termination	12

8 Cleaning the Touch Screen 13

1 Technical Data

1.1 Performance Data

Interfaces	1x CAN bus Data rate max. 1 Mbits/s
------------	--

1.2 Electrical Requirements

Supply voltage	typically +24 V DC (+18-30 V DC)	
Current consumption of power supply at +24 V	typically 60 mA	maximum 100 mA
Inrush current	typically 0.9 A for 10 ms	maximum 1.2 A for 20 ms
UL standard	for UL ⁽¹⁾ : must be supplied with SELV / PELV and Limited Energy Digital output also is SELV / Limited Energy.	

⁽¹⁾ In US according to Class 2 UL 1310 or UL 61010-1, 3rd edition, chapter 9.4 or LPS (limited power supply) UL 60950-1 or Limited Energy UL 1585

1.3 Controller

Controller	Cortex-M3
Internal data memory for visualization (SDRAM)	8-Mbyte
Internal data memory for visualization (flash)	8-Mbyte

1.4 Display

Type	3.5" LC graphic display
Resolution	320(RGB) x 240
Pixel size	0.219 x 0.219 mm
Number of pixels	320*3 (RGB) x 240 pixels
Active surface	70.08 x 52.56 mm
Color depth	24-bit
Backlighting	6x LED, white, regulatable
Contrast	400:1
TOUCH	resistive
Brightness	typically 350 cd/m ²
Visible field	left, right, below 70°, above 60°

1.5 Terminal

Operating unit dimensions	103.6 x 99.6 x 38.1 mm (W x H x D) with opposing connector 111.8 x 107.8 x 38.1 mm (W x H x D) with opposing connector and fastening clips
Control cabinet cutout	minimum 92.2 x 88.2 mm (W x H) maximum 93.5 x 89.5 mm (W x H)
Material	front plate: 3 mm anodized aluminum
Weight	ca. 250 g

1.6 Environmental Conditions

Storage temperature	-10 ... +70 °C	
Environmental temperature	0 ... +55 °C	
Humidity	10-90 %, non-condensing	
Operating conditions	Pollution degree 2 Indoor use Altitude up to 2000 m	
EMC resistance	according to EN 61000-6-2 (industrial area)	
EMC noise generation	according to EN 61000-6-4 (industrial area)	
Vibration resistance	EN60068-2-6	3.5 mm from 5-8.4 Hz 1 g from 8.4-150 Hz
Shock resistance	EN 60068-2-27	15 g
Protection type	EN 60529	front: IP65 (no UL-rating) cover: IP20 (no UL-rating)

1.7 Miscellaneous

Article number	01-230-312	
Hardware version	1.x	
Standard	UL 61010-2-201	
Approbations	UL, cUL, CE	

2 Mechanical Dimensions

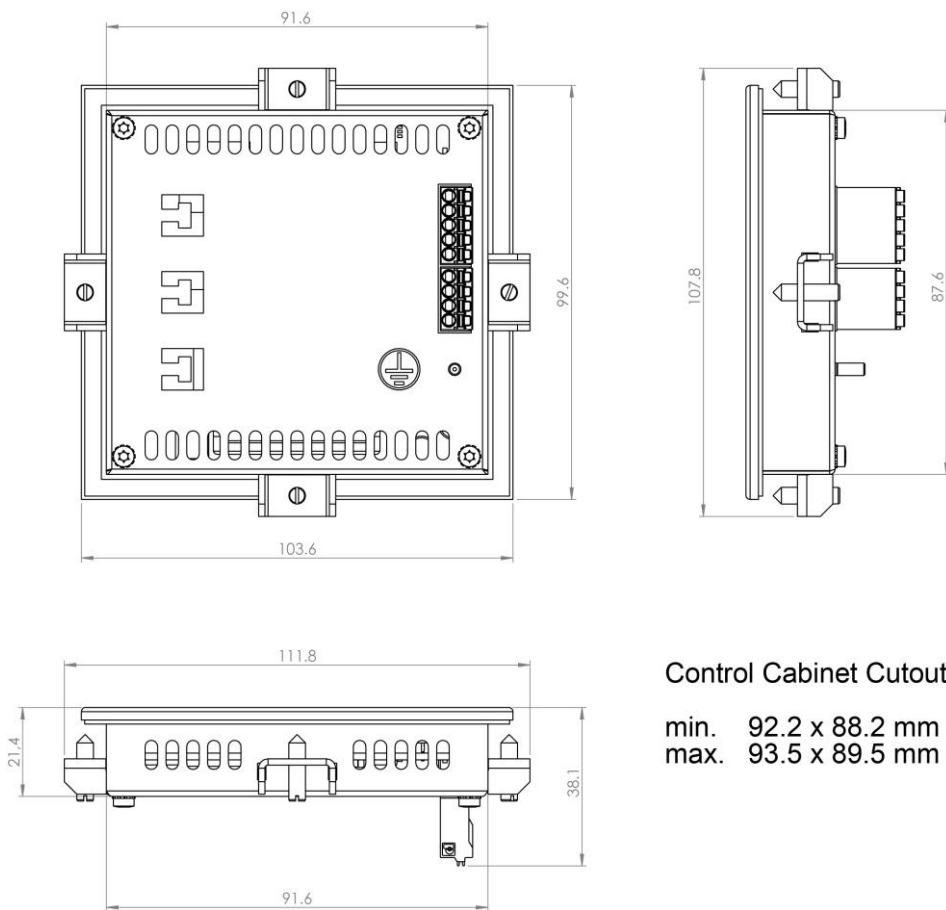

Control Cabinet Cutout:

min. 92.2 x 88.2 mm
 max. 93.5 x 89.5 mm

3 Connector Layout

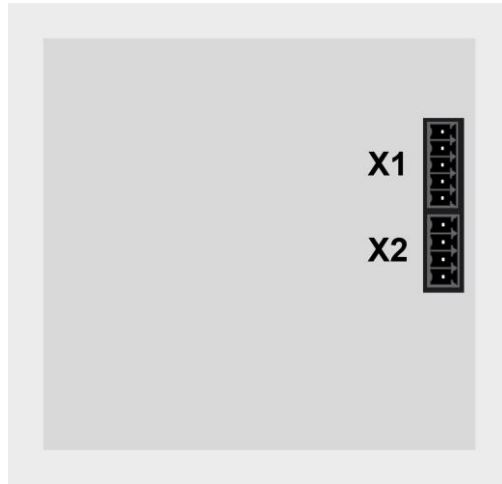

X1: CAN Bus (5-pin Phoenix RM 3.5)

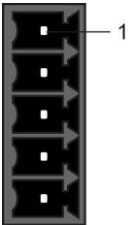

Pin	Signal	Function
1	CAN A	CAN LOW IN
2	CAN B	CAN HIGH IN
3	CAN A	CAN LOW OUT
4	CAN B	CAN HIGH OUT
5	GND	GND

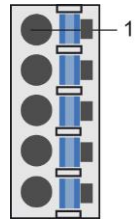

X2: Supply (4-pin Phoenix RM 3.5)

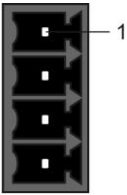

Pin	Signal	Function
1	+24 V	Supply voltage
2	+24 V	Supply voltage
3	GND	GND
4	GND	GND

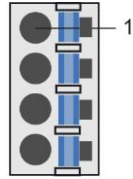

3.1 Ground Connection

M3 Threaded Bolt



Grounding is realized with a M3 threaded bolt including a latch plate. A low-Ohm connection to ground has to be established.

3.2 Applicable Connectors

Connectors:

X1-X2: Connectors with spring terminals (included in delivery)

Connections:

- Stripping length: 10 mm
- Mating direction: parallel to the conductor axis or circuit board
- Conductor cross section rigid: 0.2-1.5 mm²
- Conductor cross section flexible: 0.2-1.5 mm²
- Conductor cross section AWG/kcmil: 24-16
- Conductor cross section flexible with ferrule: 0.25-1.5 mm²
- Ferrule without with plastic sleeve:
- Conductor cross section flexible with ferrule: 0.25-0.75 mm² (reason for reduction d2 of the ferrule)
- Ferrule with plastic sleeve:

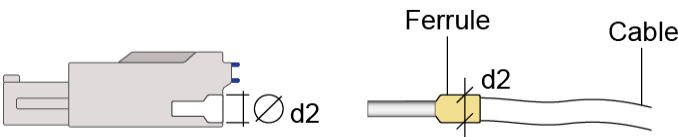

d2 = max. 2.8 mm

4 Mounting Instructions

The build-in terminal is provided for mounting in a control cabinet wall. For mounting in the control cabinet wall 4 angle clamps with threaded pins are provided. So the front is pressed against the outer control cabinet wall. The angles are fixed with a flat head screwdriver with 0.2 Nm and thus guarantee the necessary IP protection level of the front.

The modules must be mounted vertically with sufficient clearance between the ventilation slots of the build-in terminals and nearby components and/or the control cabinet back wall. This is necessary for optimal cooling and air circulation, so that proper function up to the maximum operating temperature is ensured.

4.1 Vertical Mounting Position

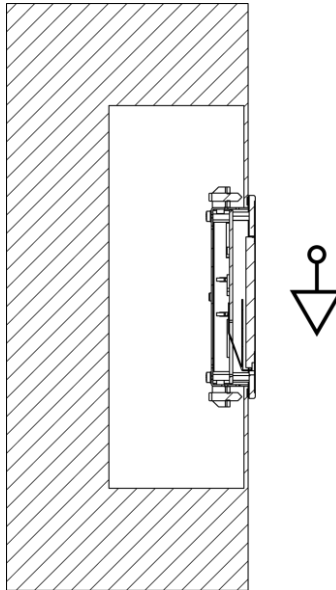

5 CAN Bus Protocol

Display communication CAN object number:

CAN bus object for receiving data: 0x200 + CAN bus station (0x00 – 0x1F)

CAN bus object for sending data: 0x040 + CAN bus station (0x00 – 0x1F)

6 CAN Bus Setup

This section explains how to correctly configure the CAN bus. The following parameters must first be set: Station number and data transfer rate.

During start up the parameters can be set on the setup screen of the terminal.

6.1 CAN Bus Station Number

Each CAN bus station is assigned its own station number. With this station number, data can be exchanged with other stations connected to the bus. Up to 31 stations can be installed in a CAN bus system. In a CAN bus system however, each station number can only be assigned once!

6.2 CAN Bus Data Transfer Rate

Various data transfer rates (baud rates) can be set on the CAN bus. The longer the bus line is, the lower the data transfer rate that must be selected.

Value	Baud Rate	Maximum Length
1	500 kBits/s	80 m
2	250 kBits/s	160 m
3	125 kBits/s	320 m
4	100 kBits/s	400 m
5	50 kbits/s	800 m
6	20 kbits/s	1200 m
7	1 Mbits/s	30 m

These values apply to the following cable: 120 Ω , Twisted Pair.

7 CAN Bus Termination

In a CAN bus system, both end modules must be terminated. This is necessary to avoid transmission errors caused by reflections in the line. For the CAN bus a shielded connector cable must be used. The shield of the cable must have a low-Ohm connection to the ground.

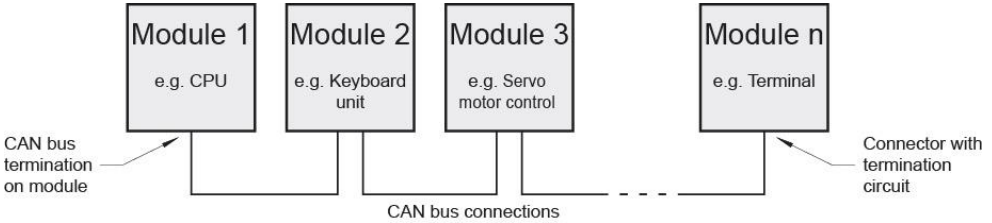

The line termination is provided by a 120 Ω resistor on the opposing connector between PIN 3 and PIN 4.

8 Cleaning the Touch Screen

CAUTION!

Before cleaning the touch screen, the terminal must first be turned off to avoid unintentionally triggering functions or commands!

The terminal's touch screen can only be cleaned with a soft, damp cloth. A screen cleaning solution such as an anti-static foam, water with a mild detergent or alcohol should be used to dampen the cloth. The cleaning solution should be sprayed onto the cloth and not directly on the terminal. The cleaning solution should not be allowed to reach the terminal electronics, for example, through the ventilation slots.

No erosive cleaning solutions, chemicals, abrasive cleansers or hard objects that can scratch or damage the touch screen may be used.

If the terminal comes in contact with toxic or erosive chemicals, carefully clean the terminal immediately to prevent corrosion!

To ensure the optimal function of the terminal, the touch screen should be cleaned at regular intervals!

To extend the lifespan of the touch screen as much as possible, using the fingers to operate the terminal is recommended.

Documentation Changes

Change date	Affected page(s)	Chapter	Note
01.03.2016	9	3.1 Ground Connection	Latch plate added
25.03.2016	5	1.4 Display	Table updated
23.01.2017	4 6	1.2 Electrical requirements 1.6 Environmental Conditions 1.7 Miscellaneous	Table content changed (UL)
07.02.2019	11	6.2 CAN-Bus Data Transfer Rate	Value 0 - Baudrate 615 kBit/s deleted