



S1A1094201

⚠️ DANGER

HAZARD OF ELECTRIC SHOCK, EXPLOSION, OR ARC FLASH

- Read and understand this quick start guide before performing any procedure with this drive.
 - The user is responsible for compliance with all international and national electrical code requirements with respect to grounding of all equipment.
 - Many parts of this drive, including the printed circuit boards, operate at the line voltage. **DO NOT TOUCH.** Use only electrically insulated tools.
 - **DO NOT** touch unshielded components or terminal strip screw connections with voltage present.
 - **DO NOT** short across terminals PA/+ and PC/- or across the DC bus capacitors.
 - Before servicing the drive:
 - Disconnect all power, including external control power that may be present.
 - Place a "DO NOT TURN ON" label on all power disconnects.
 - Lock all power disconnects in the open position.
 - **WAIT 15 MINUTES** to allow the DC bus capacitors to discharge.
 - Measure the voltage of the DC bus between the PA/+ and PC/- terminals to ensure that the voltage is less than 42 Vdc.
 - If the DC bus capacitors do not discharge completely, contact your local Schneider Electric representative. Do not repair or operate the drive
 - Install and close all covers before applying power or starting and stopping the drive.
- Failure to follow these instructions will result in death or serious injury.**

Electrical equipment should be installed, operated, serviced, and maintained only by qualified personnel. No responsibility is assumed by Schneider Electric for any consequences arising out of the use of this product.

Information below is designed to use **single drive** connected to **single motor with a motor cable length less than 50 meters (164 ft)**. In any other case, consult the ATV312 installation and programming manual on www.schneider-electric.com. Check your cables before connecting the drive with motor (length, power, shielded or unshielded). Motor cable length is _____ (<50 meters, 164 ft)

1 Check the delivery of the drive

- Remove ATV312 from the packaging and check that it has not been damaged.

⚠️ WARNING

DAMAGED DRIVE EQUIPMENT

Do not operate or install any drive or drive accessory that appears damaged.
Failure to follow these instructions can result in death, serious injury, or equipment damage.

- Check that the drive reference printed on the label is the same as that on the delivery note corresponding to the purchase order.

Write the drive Model Reference: _____ and Serial Number: _____

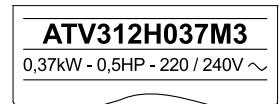

2 Check the line voltage compatibility

- Check that the **line voltage** is compatible with the supply range of the drive.
 Line voltage _____ Volts / Drive voltage range _____ Volts
 Drive range: ATV312•••••M2 = 200 ... 240 V single phase / ATV312•••••M3=200 ... 240 V three-phase
 ATV312•••••N4 = 380 ... 500 V three-phase / ATV312•••••S6 = 525 ... 600 V three-phase

3 Mount the drive vertically

For a surrounding air temperature up to 50 °C (122 °F)

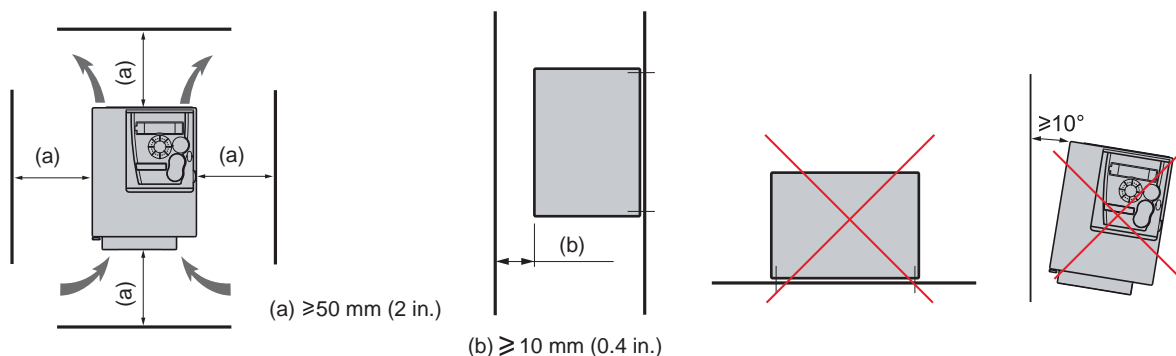

See installation manual on www.schneider-electric.com for other thermal conditions.

4 Connect the drive: Power

- Wire the drive to the ground.
- Check circuit breaker rating or fuse rating (see recommended branch circuit protection page 4).
- Check that the motor voltage is compatible with the drive voltage.
Motor voltage _____Volts.
- Wire the drive to the motor.
- Wire the drive to the line supply.

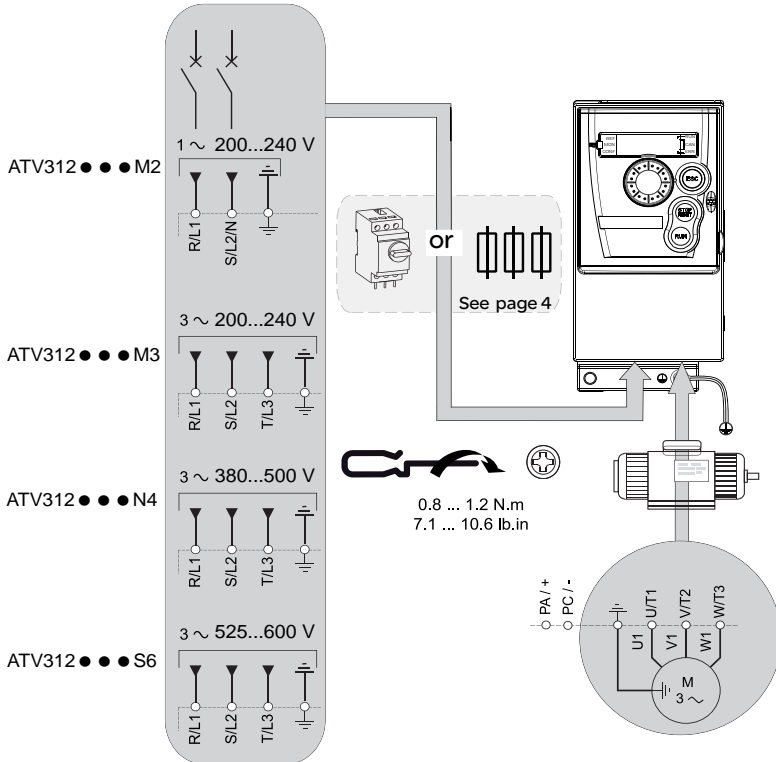

5 Connect the drive: Control choice

51 [REMOTE configuration] (Control by external reference)

- Wire the speed reference:

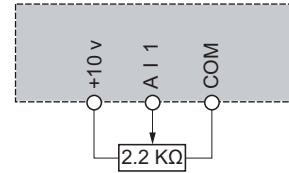

Do: 6+7+8+91

- Wire the command:
Control command 2-wire:
Parameter **CC** = **2C**

L11: forward
L12: reverse

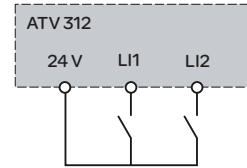

Do: 6+7+8+91

- Control uses 3-wire:
Parameter **CC** = **3C**

L11: stop
L12: forward
L1x: reverse

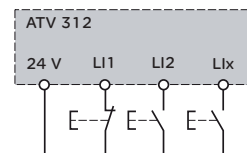

Do: 6+7+8+91

- Check SW1 = "SOURCE"



52 [LOCAL configuration] (control by internal reference).

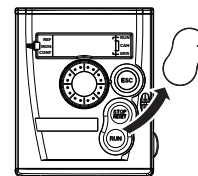

Do: 6+7+8+92

6 Apply power to the drive

- Check that used Logic Inputs are not active (see Li1, Li2, Lix).
- Apply power to the drive.
- At first power up, drive displays **n5k** (3-wire control) or **rdy** (2-wire control), after pushed drive displays **bFr**.
- On next start-ups, drive displays **n5k** or **rdy**.

7 Set motor parameters

- See on the motor Nameplate to set the following parameters in **drc** menu.

Menu	Code	Description	Factory setting	Customer setting
drc - [MOTOR CONTROL]	bFr	[Standard mot. freq]: Standard motor frequency (Hz)	50.0	
	Un5	[Rated motor volt.]: Nominal motor voltage on motor nameplate (V)	drive rating	
	Frs	[Rated motor freq.]: Nominal motor frequency on motor nameplate (Hz)	50.0	
	nCr	[Rated motor freq.]: Nominal motor current on motor nameplate (A)	drive rating	
	nSp	[Rated motorspeed]: Nominal motor speed on motor nameplate (rpm)	drive rating	
	CD5	[Motor 1 Cosinus Phi.]: Nominal motor cos φ on motor nameplate	drive rating	

7 Set motor parameters (continued)

- Set **tUn** parameter to **YES**.

Menu	Code	Description	Factory setting	Customer setting
drC - [MOTOR CONTROL]	tUn	[Auto Tuning]: Auto-Tuning for UnS, FrS, nCr, nSP, nPr and COS	nD	

⚠ ⚠ DANGER

HAZARD OF ELECTRIC SHOCK OR ARC FLASH

- During auto-tuning, the motor operates at rated current.
- Do not service the motor during auto-tuning.

Failure to follow these instructions will result in death or serious injury.

⚠ DANGER

UNINTENDED EQUIPMENT OPERATION

- The Nominal Motor Parameters **UnS, FrS, nCr, nSP, nPr** and **COS** must be correctly configured before starting auto-tuning.
- If one or more of these parameters is modified after auto-tuning has been performed, **tUn** will return to **nD** and the procedure must be repeated.

Failure to follow these instructions will result in death or serious injury.

8 Set basic parameters

Menu	Code	Description	Factory setting	Customer setting
SEt - [SETTINGS]	ACC	[Acceleration]: Acceleration time (s)	3.0	
	DEC	[Deceleration]: Deceleration time (s)	3.0	
	LSP	[Low speed]: Motor frequency at minimum reference (Hz)	0.0	
	HSP	[High speed]: Motor frequency at maximum reference (Hz)	50.0	
	IEH	[Mot. therm. current]: Nominal current indicated on the motor's rating plate (A)	drive rating	
I-D - [INPUTS / OUTPUTS CFG]	rrS	[Reverse assign.]: Reverse assignment	L12	
Fun -> PSS - [PRESET SPEEDS]	P52	[2 preset speeds]: Preset speeds	L13	
	P54	[4 preset speeds]: Preset speeds	L14	
Fun -> SA1 - [SUMMING INPUTS]	SA2	[Summing ref. 2] Analog input	A12	

9 Set control choice

Menu	Code	Description	5.1 [REMOTE configuration]	5.2 [LOCAL configuration]	Customer Setting
CtL - [COMMAND]	Fr1	[Ref.1 channel]: Reference control	A11, A12, A13	A1U1	
I-D - [INPUTS / OUTPUTS CFG]	tCC	[2/3 wire control]: Command control	2C : 2-wire 3C : 3-wire	L0C	

91 [REMOTE configuration] (Configuration factory setting)

Parameters factory settings:

Fr1 = A11
tCC = 2C

92 [LOCAL configuration]

Parameters factory settings:

Fr1 = A1U1
tCC = L0C
rrS = L12
P52 = L13
P54 = L14

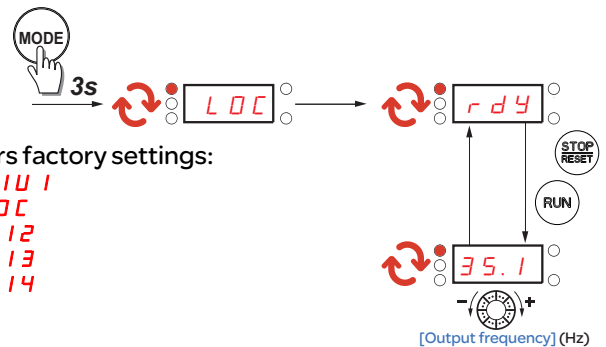

10 Start the motor

Menus structure

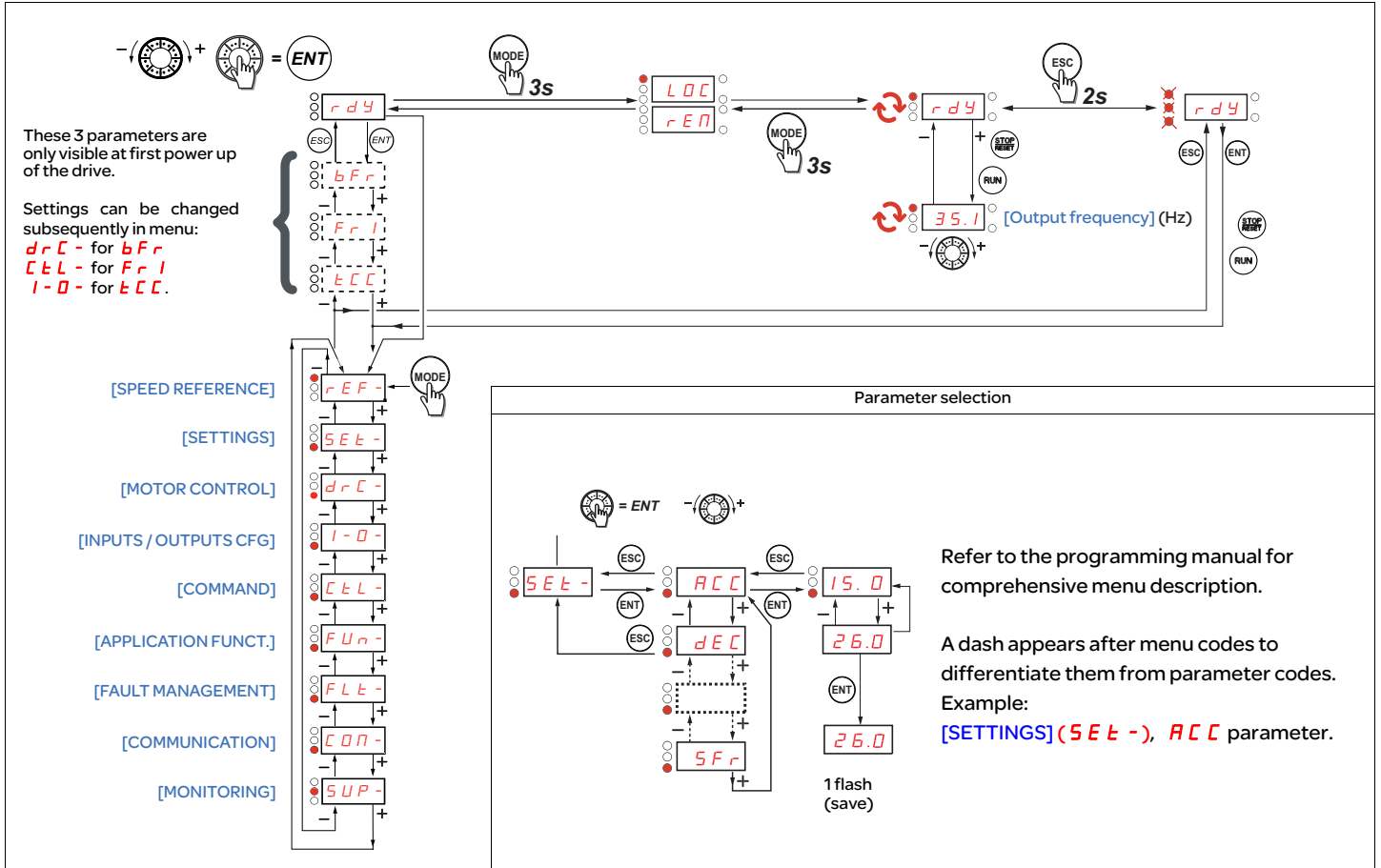

Short-circuit rating and branch circuit protection.

Reference	Voltage (V)	Input withstand rating (1)	Output interrupt rating (X)(2)	Enclosure Containment rating (3) (Type 1)	Branch Circuit protection (Z1)	Rating (Z2)
	V	KA	KA	KA		A
ATV312H018M2	200-240	1	22	/	Class J Fuse	6
ATV312H037M2	200-240	1	22	/	Class J Fuse	10
ATV312H055M2	200-240	1	22	/	Class J Fuse	10
ATV312H075M2	200-240	1	22	/	Class J Fuse	15
ATV312HU11M2	200-240	1	22	/	Class J Fuse	20
ATV312HU15M2	200-240	1	22	/	Class J Fuse	20
ATV312HU22M2	200-240	1	22	/	Class J Fuse	30
ATV312H018M3	200-240	5	22	22	Class J Fuse	3
ATV312H037M3	200-240	5	22	22	Class J Fuse	6
ATV312H055M3	200-240	5	22	22	Class J Fuse	10
ATV312H075M3	200-240	5	22	22	Class J Fuse	10
ATV312HU11M3	200-240	5	22	22	Class J Fuse	15
ATV312HU15M3	200-240	5	22	22	Class J Fuse	15
ATV312HU22M3	200-240	5	22	22	Class J Fuse	20
ATV312HU30M3	200-240	5	22	22	Class J Fuse	25
ATV312HU40M3	200-240	5	22	22	Class J Fuse	35
ATV312HU55M3	200-240	22	22	22	Class J Fuse	50
ATV312HU75M3	200-240	22	22	22	Class J Fuse	60
ATV312HD11M3	200-240	22	22	22	Class J Fuse	80
ATV312HD15M3	200-240	22	22	22	Class J Fuse	110
ATV312H037N4	380-500	5	22	100	Class J Fuse	3
ATV312H055N4	380-500	5	22	100	Class J Fuse	6
ATV312H075N4	380-500	5	22	100	Class J Fuse	6
ATV312HU11N4	380-500	5	22	100	Class J Fuse	10
ATV312HU15N4	380-500	5	22	100	Class J Fuse	10
ATV312HU22N4	380-500	5	22	100	Class J Fuse	15
ATV312HU30N4	380-500	5	22	100	Class J Fuse	15
ATV312HU40N4	380-500	5	22	100	Class J Fuse	20
ATV312HU55N4	380-500	22	22	100	Class J Fuse	30
ATV312HU75N4	380-500	22	22	100	Class J Fuse	35
ATV312HD11N4	380-500	22	22	100	Class J Fuse	50
ATV312HD15N4	380-500	22	22	100	Class J Fuse	70
ATV312H075S6	525-600	5	22	22	Class J Fuse	6
ATV312HU15S6	525-600	5	22	22	Class J Fuse	6
ATV312HU22S6	525-600	5	22	22	Class J Fuse	10
ATV312HU40S6	525-600	5	22	22	Class J Fuse	15
ATV312HU55S6	525-600	22	22	22	Class J Fuse	20
ATV312HU75S6	525-600	22	22	22	Class J Fuse	25
ATV312HD11S6	525-600	22	22	22	Class J Fuse	35
ATV312HD15S6	525-600	22	22	22	Class J Fuse	45

Recommended fuse ratings for UL and CSA requirements. Components for use together in accordance with standard UL508

Suitable For Use On A Circuit Capable Of Delivering Not More Than ___X___ rms Symmetrical Amperes, ___Y___ Volts Maximum, When Protected by ___Z___ with a Maximum rating of ___Z2___.

(1) Input withstand rating is that for which the product has been designed thermally. Installation on a supply greater than this level will require additional inductance to satisfy this level.

(2) Output interrupt rating relies on Integral solid state short circuit protection. This does not provide branch circuit protection. Branch circuit protection must be provided in accordance with the National Electrical Code and any additional local codes. This is dependant on the type of installation.

(3) Enclosure Containment Rating is the maximum input short-circuit current at the drive input terminals with the specific branch Circuit Protection present for which any internal component breakdown, will not create a shock, flame, fire or expulsion hazard