

Control Panel

ETV 0555

The control panel is an intelligent terminal for programming and visualization of automated processes. Process diagnosis as well as operating and monitoring automated procedures is simplified using this terminal.

A touch-screen serves as the input medium for process data and parameters; the output is shown on a 5.7" VGA TFT color display.

With the LSE mask editor, graphics can be created on the PC, then stored and displayed on the terminal.

The available interface connections can be used to exchange process data or configure the terminal. A micro SD card serves as the storage medium for the operating system, application and application data.

With the integrated VARAN manager, the ETV 0555 offers the possibility to construct a high-performance VARAN system to operate for example, decentralized I/O modules, drive systems or communication modules.



Contents

Technical Data	3
Mechanical Dimensions	7
Connector Layout	8
Front.....	8
Connections on Rear and Bottom	9
Buffer Battery	14
Exchanging the Battery	15
BIOS	18
Cooling	18
Mounting Instructions	18
Wiring Guidelines	19
Earth Connection	19
Shielding	19
ESD Protection.....	19
USB Interface Connections	19
CAN Bus Setup	20
CAN Bus Termination	21
Process Diagram	22
Status and Error Messages	23
Application exceptions	31
Note on SRAM Behavior	32
Recommended Shielding for VARAN	33
1. Wiring from the Control Cabinet to an External VARAN Component.....	34
2. Wiring Outside of the Control Cabinet	35
3. Shielding for Wiring Within the Control Cabinet.....	36
4. Connecting Noise-Generating Components	37
5. Shielding Between Two Control Cabinets	38
Cleaning the Touch Screen	39

Technical Data

Performance Data

Processor	EDGE-Technology X86 compatible
Internal cache	32-kbyte L1 Cache 256-kbyte L2 Cache
BIOS	AMI
Internal program and data memory (DDR2 RAM)	64 Mbytes
Internal remnant data memory	512 Kbytes ⁽¹⁾
Internal storage device (IDE)	512 MByte microSD or 1 GByte microSD
Internal I/O	Yes
Interface connections	2 x USB 2.0, Type A (Full speed 12 Mbit/s) 1 x USB 1.1, Type Mini B 1 x Ethernet 1 x VARAN-Out (Manager) (max. length: 100 m) 1 x CAN-Bus
Internal interface connections and devices	1 x TFT-LCD color display 1 x Touch
Display	5.7" TFT color display
Resolution	640 x 480 Pixel
Control panel	4-wire touch screen (analog resistive)
Data buffer	Yes
Signal generator	No
Status leds	No
Real-time clock	Yes (buffering via battery)
Cooling	Passive (fanless)

⁽¹⁾ See chapter "Note on SRAM Behavior"

Electrical Requirements

Supply voltage	Typically +24 V DC	
	Minimum +18 V DC	Maximum +30 V DC
Current consumption of the +24 V supply	Typically 335 mA (with no external devices connected)	Maximum 610 mA (with external devices connected)
Starting current	Maximum 28 A for 20 μ s	

The device shall be supplied from an isolating transformer having a secondary listed fuse rated either:

- a) max. 5 amps for voltages 0~20 V (0~28.3 Vp), or
- b) 100 VA/Vp for voltages of 20~30 V (28.3~42.4 Vp).

Le module doit être alimenté par un transformateur d'isolement avec un fusible sur la sortie de l'enroulement secondaire dont les spécifications sont:

- a) max. 5 A pour des tensions 0 ~ 20 V (0 ~ 28,3 Vp), ou
- b) 100 VA/Vp pour des tensions de 20 ~ 30 V (28,3 ~ 42,4 Vp).

Terminal

Dimensions	180 mm / 135 mm / 40.4 mm (W x H x D)
Material	Front plate: 3.5 mm anodized aluminum
Weight	650 g

Environmental Conditions

Storage temperature	-10 – +85 °C	
Operating temperature	0 – 50 °C	
Humidity	10 - 90 %, uncondensed	
EMV stability	EN 61000-6-2: noise resistance EN 61000-6-4: noise emission	
Vibration tolerance	EN 60068-2-6	2 – 9 Hz: Amplitude 3.5 mm 9 – 200 Hz: 1 g (10 m/s ²)
Shock resistance	EN 60068-2-27	150 m/s ²
Protection Type	EN 60529 protection through housing	Front: IP54 Cover: IP20

5.7" VGA Display

Type	5.7" LCD color display
Resolution	VGA 640 x 480 Pixel
Color depth	18-bit RGB (262K colors)
LCD mode	TN / normal white
LCD Polarizer	Transmissive
Pixel size	0.18 mm x 0.18 mm
Active surface	115.2 mm x 86.4 mm
Background lighting	LED
Contrast	600 : 1
Brightness	Typically 350 cd/m ²
Visible field CR _{>=} 10	Left, right, below 75°, above 60°

Control Unit

Touch panel	Analog resistive glass touch panel
Resolution	12-Bit (4096 x 4096)
Connection technology	4-wire

Digital Outputs

Number of ...	8
Short-circuit proof	Yes
Maximum continuous current load allowed per channel	2 A
Maximum total current (all 8-channels)	6 A (100 % of on-time)
Voltage drop over power supply (output active)	≤ 1 V
Residual output current (inactive)	≤ 12 μ A
Turn-on delay	< 400 μ s
Turn-off delay	< 400 μ s
Max. Max. braking energy of inductive loads	1 channel 0.12 [Joules]

Digital Inputs

Number of ...	8	
Input voltage	Typically +24 V	Maximum +30 V
Signal level	low: $< +4.5$ V	High : $> +14$ V
Switching threshold	Typically +11 V	
Input current	Typically 5 mA at + 24 V	
Input delay	Typically 5 ms	

Miscellaneous

Article number	12-230-0555 (512 MB microSD Card) 12-230-0555-1 (1 GB microSD Card)
Hardware version	2.x – 3.x
Standardization	UL 508 (E247993)

Mechanical Dimensions

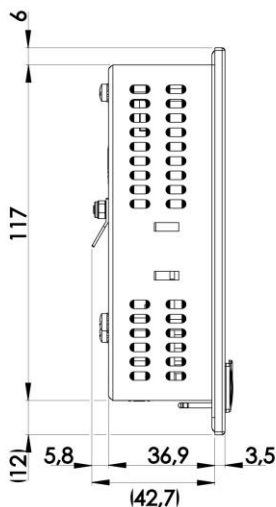
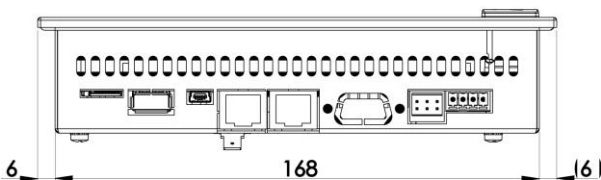
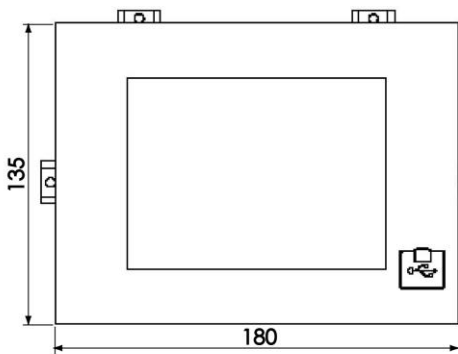

Connector Layout

Front



USB 2.0 (Typ A, Full Speed 12 Mbit/s)

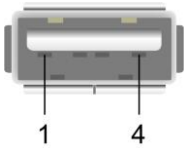

Pin	Function
1	+5 V_USB
2	D-
3	D+
4	GND

Connections on Rear and Bottom

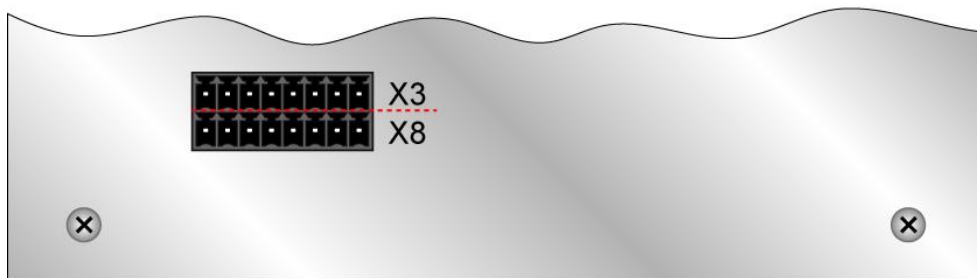
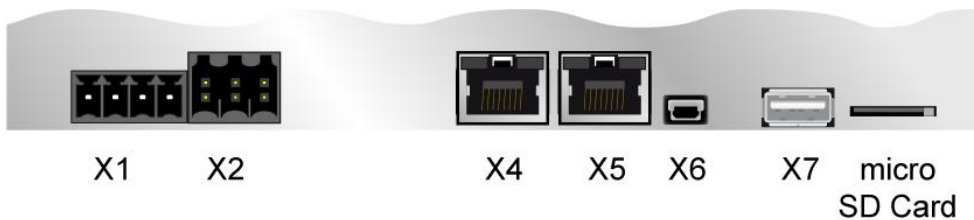

X1: Power plug

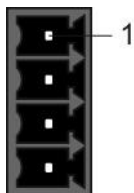

Pin	Function
1	+24 V DC DIG IOs
2	+24 V DC
3	GND
4	GND

X2: CAN

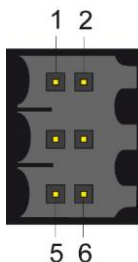

Pin	Function
1	CAN A (CAN LOW)
2	CAN B (High)
3	CAN A (CAN LOW)
4	CAN B (High)
5	GND
6	n.c.

n.c. = do not use

X3 and X8: 8 digital inputs, 8 digital outputs

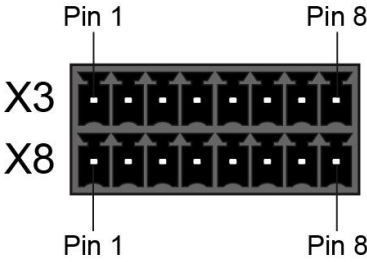

X3: Pin assignment

Pin	Function
1	Output 1
2	Output 2
3	Output 3
4	Output 4
5	Input 1
6	Input 2
7	Input 3
8	Input 4

X8: Pin assignment

Pin	Function
1	Output 5
2	Output 6
3	Output 7
4	Output 8
5	Input 5
6	Input 6
7	Input 7
8	Input 8

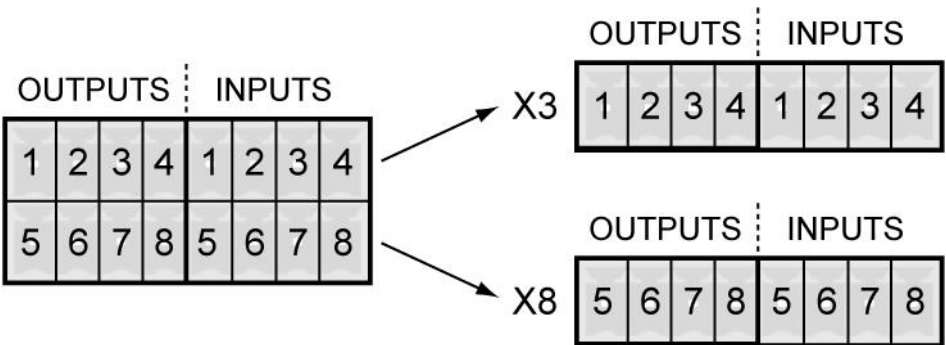

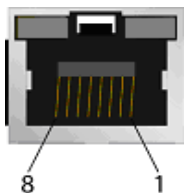
X4: Ethernet

Pin	Function
1	RX +
2	RX -
3	TX +
4	n.c.
5	n.c.
6	TX -
7	n.c.
8	n.c.

n.c. = do not use

Problems can arise if a control is connected to an IP network, which contains modules that are not running with a SIGMATEK operating system. With such devices, Ethernet packets could be sent to the control with such a high frequency (i.e. broadcasts), that the high interrupt load could cause a real-time runtime error or runtime error. By configuring the packet filter (Firewall or Router) accordingly however, it is possible to connect a network with SIGMATEK hardware to a third party network without triggering the error mentioned above.

Des problèmes peuvent survenir si un automate est connecté à un réseau IP contenant des modules qui ne fonctionnent pas sous un système d'exploitation SIGMATEK. Avec de tels dispositifs, les paquets Ethernet peuvent être envoyés à l'automate avec une fréquence tellement élevée (càd. diffusion), que les interruptions ainsi générées peuvent provoquer une erreur d'exécution. En configurant d'une façon appropriée le filtre de paquets (pare-feu ou un routeur) il est toutefois possible de connecter un réseau avec le matériel SIGMATEK à un réseau tiers sans déclencher l'erreur mentionnée ci-dessus.

For use in local networks only, not telecommunication circuits.

Pour une utilisation dans les réseaux locaux uniquement, et non pas dans de circuits de télécommunications.

X5: VARAN-Out

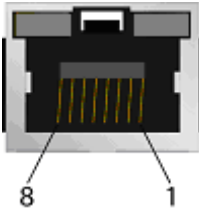

Pin	Function
1	TX+ / RX+
2	TX- / RX-
3	RX+ / TX+
4	n.c.
5	n.c.
6	RX- / TX-
7	n.c.
8	n.c.

More information on the VARAN bus can be found in the VARAN bus specifications!

X6: USB 1.1 (Type Mini B)

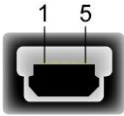

Pin	Function
1	+5 V
2	D-
3	D+
4	n.c.
5	GND

X7: USB 2.0 (Type A, Full Speed 12 Mbit/s)

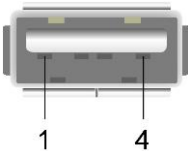

Pin	Function
1	+5 V_USB
2	D-
3	D+
4	GND

It should be noted that many of the USB devices on the market do not comply with USB specifications; this can lead to device malfunctions. It is also possible that these devices will not be detected at the USB port or function correctly. Therefore, it is recommended that every USB stick be tested before actual use.

Il faut souligner que la plupart des périphériques USB sur le marché ne sont pas conformes aux spécifications USB, ce qui peut entraîner des dysfonctionnements de l'appareil. Il est également possible que ces dispositifs ne seront pas détectés par le port USB ou qu'ils ne fonctionnent pas correctement. Par conséquent, il est recommandé que chaque clé USB soit testée avant l'utilisation sur l'automate.

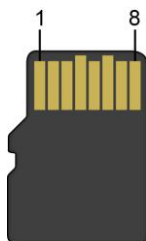
X6: microSD Card

Pin	Function
1	DAT2
2	CD/DAT3
3	CMD
4	+3V3
5	CIK
6	GND
7	DAT0
8	DAT1

It is recommended that only storage media provided by SIGMATEK (CompactFlash cards, microSD cards etc.) be used.

Order number for the 512-Mbyte EDGE microSD card: 12-630-051

Order number for the 1-Gbyte EDGE microSD card: 12-630-101

The number of read and write actions have a significant influence on the lifespan of the storage media.

Il est recommandé de n'utiliser que les supports de stockage approuvés par SIGMATEK (compact flash, microSD, etc.).

Numéro de commande pour la carte microSD 512 Mo Edge est le: 12-630-051

Numéro de commande pour la carte microSD 1 Go Edge est le: 12-630-101

Le nombre de cycles de lecture et d'écriture a l'influence notable sur la durée de vie des supports de stockage.

Applicable connectors

CAN-Bus: 6-pin Weidmüller plug, B2L3,5/6

USB: 4-pin, type A (downstream connector)

Ethernet: 8-pin RJ45

VARAN: 8-pin RJ45

Power supply: 4-pin Phoenix plug with screw terminal technology MC 1,5/ 4-ST-3.5

4-pin Phoenix plug with spring terminal FK-MCP 1,5/ 4-ST-3.5

Digitale IO's: 2 x 8-pin Phoenix plug with spring terminal FMC 1,5/ 8-ST-3.5

The complete CKL 213 connector set is available from SIGMATEK under the article number 12-600-213.

Buffer Battery

The exchangeable buffer battery ensures that the clock time (RTC) is preserved in the absence of a supply voltage. A lithium battery is installed at the manufacturer.

The battery has enough capacity to preserve data in the absence of a supply voltage for up to 7 years.

Battery order number: 01-690-055

	MANUFACTURER	DATA
Lithium battery	RENATA	3.0 V / 235 mAh

Use batteries from RENATA with the number CR2032 only!
WARNING! Battery may explode if mistreated! Do not recharge, disassemble or dispose of in fire!

Remplacer la pile avec RENATA, modèle n° CR2032 uniquement! Utilisation d'une autre pile peut présenter un risque d'incendie ou d'explosion!

Exchanging the Battery

1. Disconnect the power to the ETV.
2. Open the locking screws on the back of the terminal with a PH-1 screwdriver:



3. Lift rear panel of the terminal:

For HW version 1.x:

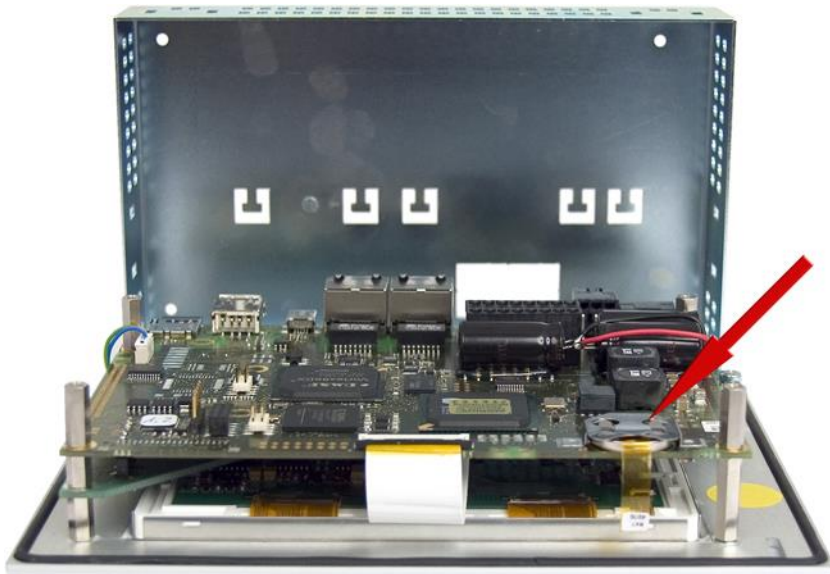

4. Using the strap, remove the battery the holder (see arrow).

5. Place the new battery in the holder with the correct polarity and replace the cover.
(+ Pole toward the backside)

From HW version 2.x:

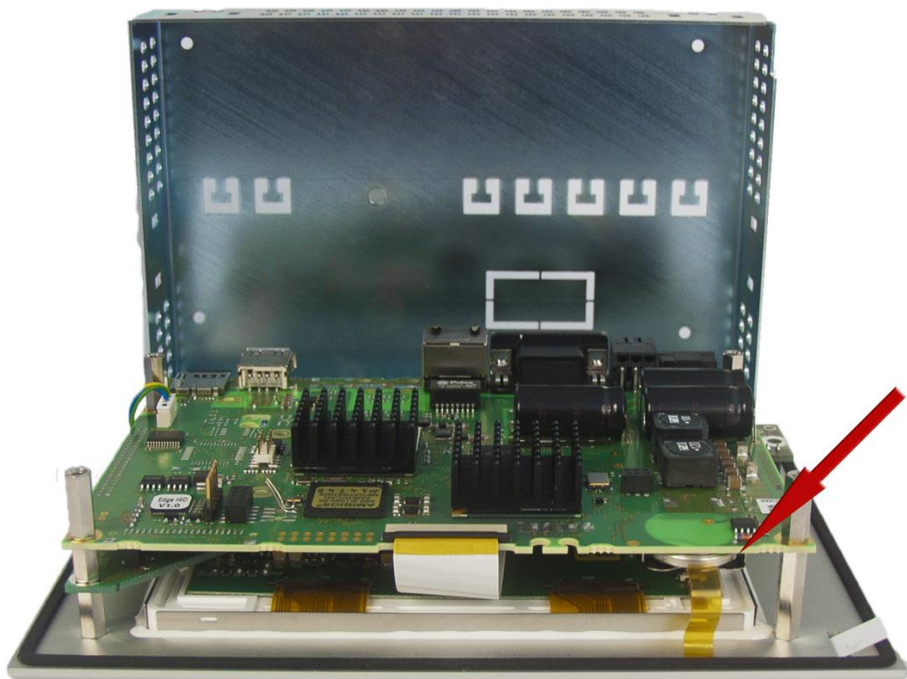

4. Using the strap, remove the battery from the holder (see arrow).
5. Place the new battery in the holder with the correct polarity (+ Pole toward the frontside) and replace the cover.

BIOS

The BIOS is configured so that the LASAL operating system is booted from the SD card.

Cooling

The terminal's power loss can reach up to 10 Watts. To ensure the necessary air circulation for cooling, the following mounting instructions must be followed!

Mounting Instructions

The following clearance is required for the cover:

- Rear side, left and right 5 cm
- Above and below 10 cm

The mounting angle must also be between 60° and 120°.

Wiring Guidelines

Earth Connection

The terminal must be connected to earth through the mounting on control cabinet or over the terminal provided. It is important to create a low-ohm earth connection, only then can error-free operation be guaranteed. The earth connection should have the maximum cross section and the largest electrical surface possible.

Shielding

With Ethernet, CAT5 cables with shielded RJ45 connectors are required. The shielding in the CAT5 cable is connected to earth through the RJ45 connector. Noise signals can therefore be prohibited from reaching the electronics and affecting the function.

ESD Protection

Typically, USB devices (keyboard, mouse) are not equipped with shielded cables. These devices are disrupted by ESD and in some instances, no longer function.

Before any device is connected to or disconnected from the terminal, the potential should be equalized (by touching control cabinet or earth terminal). Static electricity (from clothing, footwear) can therefore be reduced.

USB Interface Connections

The terminal has a USB interface connection that can be used to connect various USB devices (keyboard, mouse, storage media, hubs, etc.) in LASAL. Several USB devices, which are fully functional in LASAL, can be connected using a hub.

CAN Bus Setup

This section explains how to configure a CAN bus correctly. The following parameters must first be set: Station number and data transfer rate.

CAN bus station number

Each CAN bus station is assigned its own station number. With this station number, data can be exchanged with other stations connected to the bus. Up to 31 stations can be installed in a CAN bus system. However, each station number can only be assigned once.

CAN bus data transfer rate

The data transfer rate (baud rate) for the CAN bus can be set. However, the longer the length of the bus, the smaller the transfer rate that must be selected.

Value	Baud rate	Maximum length
0	615 kBit/s	60 m
1	500 kBit/s	80 m
2	250 kBit/s	160 m
3	125 kBit/s	320 m
4	100 kBit/s	400 m
5	50 kBit/s	800 m
6	20 kBit/s	1200 m
7	1 Mbit / s	30 m

These values are valid for the following cable: 120 Ω , Twisted Pair.

NOTE: the following is valid for the CAN bus protocol: 1 kBit/s = 1 kBaud.

CAN Bus Termination

In a CAN bus system, both end modules must be terminated. This is necessary to avoid transmission errors caused by reflections in the line.

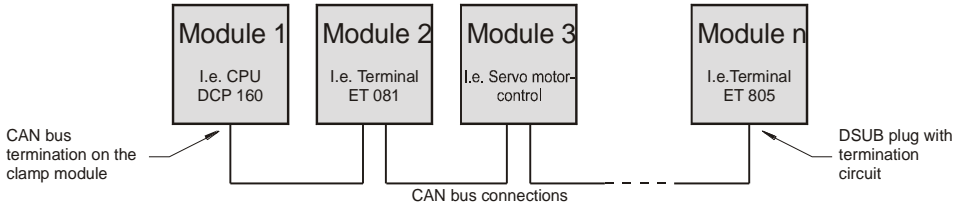

If the terminal is an end module, it can be terminated by placing a 150-Ohm resistor between CAN-A (Low) and CAN-B (High).



Process Diagram

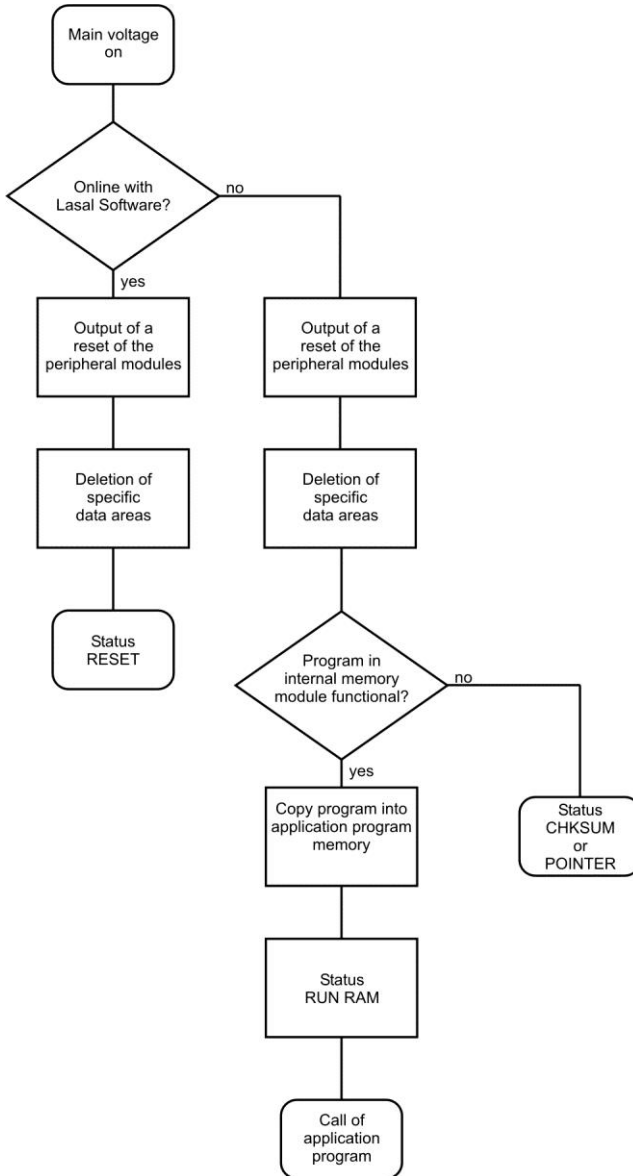

Status and Error Messages

Status and error messages are shown in the status test of the Lasal Class software. POINTER or CHKSUM messages are shown on the terminal screen.

Number	Message	Definition	Cause/solution
00	RUN RAM	The user program is currently running in RAM. The display is not affected.	Info
01	RUN ROM	The user program in the program memory module was loaded into the RAM and is currently being run. The display is not affected.	Info
02	RUNTIME	The total duration of all cyclic objects exceeds the maximum time; the time can be configured using 2 system variables: - Runtime: time remaining - SWRuntime: pre-selected value for the runtime counter	Optimize the application's cyclic task. Use higher capacity CPU Configure preset value
03	POINTER	Incorrect program pointers were detected before running the user program	Possible Causes: - The program memory module is missing, not programmed or defect. - The program in the user program memory (RAM) is not executable. - The buffering battery has failed. - The user program has overwritten a software error. Solution: - Reprogram the memory module, if the error reoccurs exchange the module. - Exchange the buffering battery - Correct programming error
04	CHKSUM	An invalid checksum was detected before running the user program.	Cause/solution: s. POINTER

05	Watchdog	The program was interrupted through the watchdog logic.	<p>Possible Causes:</p> <ul style="list-style-type: none"> - User program interrupts blocked over a longer period of time (STI command forgotten) - Programming error in a hardware interrupt. - INB, OUTB, INW, OUTW instructions used incorrectly. - The processor is defect. <p>Solution:</p> <ul style="list-style-type: none"> - Correct programming error. - Exchange CPU.
06	GENERAL ERROR	<p>General error</p> <p>An error has occurred while stopping the application over the online interface.</p>	The error occurs only during the development of the operating system.
07	PROM DEFECT	An error has occurred while programming the memory module.	<p>Cause:</p> <ul style="list-style-type: none"> - The program memory module is defect. - The user program is too large. - The program memory module is missing. <p>Solution:</p> <ul style="list-style-type: none"> - Exchange the program memory module
08	Reset	<p>The CPU has received the reset signal and is waiting for further instructions.</p> <p>The user program is not processed.</p>	Info
09	WD DEFECT	<p>The hardware monitoring circuit (watchdog logic) is defect.</p> <p>After power-up, the CPU checks the watchdog logic function. If an error occurs during this test, the CPU deliberately enters an infinite loop from which no further instructions are accepted.</p>	Solution: Exchange CPU.
10	STOP	The program was stopped by the programming system.	
11	PROG BUSY	Reserved	
12	PROGRAM LENGTH	Reserved	

13	PROG END	The memory module was successfully completed.	Info
14	PROG MEMO	The CPU is currently programming the memory module.	Info
15	STOP BRKPT	The CPU was stopped by a breakpoint in the program.	Info
16	CPU STOP	The CPU was stopped by the programming software.	Info
17	INT ERROR	The CPU has triggered a false interrupt and stopped the user program or has encountered an unknown instruction while running the program.	Cause: - A nonexistent operating system was used. - Stack error (uneven number of PUSH and POP instructions). - The user program was interrupted by a software error. Solution: - Correct programming error.
18	SINGLE STEP	The CPU is in single step mode and is waiting for further instructions.	Info
19	Ready	A module or project has been sent to the CPU and it is ready to run the program.	Info
20	LOAD	The program has stopped and is receiving a module or project.	Info
21	UNZUL. Modul	The CPU has received a module, which does not belong to the project.	Solution: - Recompile and download the entire project
22	MEMORY FULL	The operating system memory /Heap) is too small. No more memory could be reserved, when an internal or interface function was called from the application.	Cause: - Memory is only allocated but not released. Solution: Clear memory
23	NOT LINKED	When starting the CPU, a missing module or a module that does not belong to the project was detected.	Solution: - Recompile and download the entire project

24	DIV BY 0	A division error has occurred.	<p>Possible Causes:</p> <ul style="list-style-type: none"> - Division by 0. - The result of a division does not fit in the result register. <p>Solution:</p> <ul style="list-style-type: none"> - Correct programming error.
25	DIAS ERROR	An error has occurred while accessing a DIAS module.	Hardware problem
26	WAIT	The CPU is busy.	Info
27	OP PROG	The operating system is currently being reprogrammed.	Info
28	OP INSTALLED	The operating system has been reinstalled.	Info
29	OS TOO LONG	The operating system cannot be loaded; too little memory.	Restart; report error to Sigmatek.
30	NO OPERATING SYSTEM	Boot loader message. No operating system found in RAM.	Restart; report error to Sigmatek.
31	SEARCH FOR OS	The boot loader is searching for the operating system in RAM.	Restart; report error to Sigmatek.
32	NO DEVICE	Reserved	
33	UNUSED CODE	Reserved	
34	MEM ERROR	The operating system loaded does not match the hardware configuration.	- Use the correct operating system version
35	MAX IO	Reserved	
36	MODULE LOAD ERROR	The LASAL Module or project cannot be loaded.	<p>Solution:</p> <ul style="list-style-type: none"> - Recompile and download the entire project
37	BOOTIMAGE FAILURE	A general error has occurred while loading the operating system.	Contact SIGMATEK
38	APPLMEM ERROR	An error has occurred in the application memory (user heap).	<p>Solution:</p> <ul style="list-style-type: none"> - Correct allocated memory access error
39	OFFLINE	This error does not occur in the control.	This error code is used in the programming system to show that there is no connection to the control.
40	APPL LOAD	Reserved	

41	APPL SAVE	Reserved	
44	VARAN MANAGER ERROR	An error number was entered in the VARAN manager and stopped the program.	Solution: - Read logfile
45	VARAN ERROR	A required VARAN client was disconnected or there was a communications error with a VARAN client.	Solution: - Read logfile - Error Tree
46	APPL-LOAD-ERROR	An error has occurred while loading the application.	Cause: - Application was deleted. Solution: - Reload the application into the control.
47	APPL-SAVE-ERROR	An error has occurred while attempting to save the application.	
50	ACCESS-EXCEPTION-ERROR	Read or write access of a restricted memory area. (i.e. writing to the NULL pointer).	Solution: - Correct application errors
51	BOUND EXCEEDED	An exception error has occurred when accessing arrays. The memory area was overwritten through accessing an invalid element.	Solution: - Correct application errors
52	PRIVILEGED INSTRUCTION	An invalid instruction for the CPU level, i.e. setting the segment register.	Cause: - The application has overwritten the application program code. Solution: - Correct application errors
53	FLOATING POINT ERROR	An error has occurred during a floating-point operation.	
60	DIAS-RISC-ERROR	Error from the Intelligent DIASMaster.	Restart; report error to Sigmatek.
64	INTERNAL ERROR	An internal error has occurred, all applications are stopped.	Restart; report error to Sigmatek.
65	FILE ERROR	An error has occurred during a file operation.	
66	DEBUG ASSERTION FAILED	Internal error.	Restart; report error to Sigmatek.

67	REALTIME RUNTIME	The total duration of all real-time objects exceeds the maximum time; the time cannot be configured. 2 ms for 386 CPUs 1 ms for all other CPUs	Solution: - Optimize the application's realtime task (RtWork). - Reduce the clock time for the realtime task of all objects. - Correct application errors - CPU is overloaded in realtime => use a higher capacity CPU.
68	BACKGROUND RUNTIME	The total duration of all background objects exceeds the maximum time; the time can be configured using 2 system variables: -BTRuntime: time remaining -SWBTRuntime: pre-selected value for the runtime counter	Solution: - Optimize the application's background task (background) - Use higher capacity CPU - Set SWBTRuntime correctly.
70	C-DIAS ERROR	An error occurred in connection with a C-DIAS module.	Cause: - The reason for this error is documented in the log file Solution: - Depends on the cause
72	S-DIAS ERROR	A connection error with a S-DIAS module has occurred.	Possible causes: - real network does not match the project - S-DIAS client is defective Solution: - analyze logfile
75	SRAM ERROR	Only EDGE CPUs An error occurred while initializing, reading or writing SRAM data.	Possible causes: - - SRAM configured incorrectly - - SD card formatted incorrectly - - SD card removed Solution: - - evaluate log file (Event00.log) - - check configuration - - format SD card as EDGE medium with Lasal Class 2 - - check SD card
95	USER DEFINED 0	User-definable code.	
96	USER DEFINED 1	User-definable code.	
97	USER DEFINED 2	User-definable code.	
98	USER DEFINED 3	User-definable code.	

99	USER_DEFINED_4	User-definable code.	
100	C_INIT	Initialization start; the configuration is run.	
101	C_RUNRAM	The LASAL project was successfully started from RAM.	
102	C_RUNROM	The LASAL project was successfully started from ROM.	
103	C_RUNTIME		
104	C_READY	The CPU is ready for operation.	
105	C_OK	The CPU is ready for operation.	
106	C_UNKNOWN_CID	An unknown class from a stand-alone or embedded object: unknown base class.	
107	C_UNKNOWN_CONSTR	The operating system class cannot be created; the operating system is probably wrong.	
108	C_UNKNOWN_OBJECT	Reference to an unknown object in an interpreter program, creation of more than one DCC080 object.	
109	C_UNKNOWN_CHNL	The hardware module number is greater than 60.	
110	C_WRONG_CONNECT	No connection to the required channels.	
111	C_WRONG_ATTR	Wrong server attribute.	
112	C_SYNTAX_ERROR	No specific error, recompile all and reload project components.	
113	C_NO_FILE_OPEN	An attempt was made to open an unknown table.	
114	C_OUTOF_NEAR	Memory allocation error	
115	C_OUT_OF_FAR	Memory allocation error	
116	C_INCOMAPTIBLE	An object with the same name exists but has another class.	
117	C_COMPATIBLE	An object with the same name and class exists but must be updated.	
224	LINKING	The application is currently linking.	
225	LINKING ERROR	An error has occurred while linking. An error message is generated in the LASAL status window.	
226	LINKING DONE	Linking is complete.	

230	OP BURN	The operating system is currently being burned into the Flash memory.	
231	OP BURN FAIL	An error has occurred while burning the operating system.	
232	OP INSTALL	The operating system is currently being installed.	
240	USV-WAIT	The power supply was disconnected; the UPS is active. The system is shutdown.	
241	Reboot	The operating system is restarted.	
242	LSL SAVE		
243	LSL LOAD		
252	CONTINUE		
253	PRERUN	The application is started.	
254	PRERESET	The application is ended.	
255	CONNECTION BREAK		

Application exceptions

SRAM and IRQ routines

Writing remnant data during interrupt routines is not allowed and leads to a system crash.

SRAM and consistency of changed data

If more than 32 different sectors are changed (512 bytes each) shortly before shutting down the voltage supply while the user program is writing to the Micro SD card, this can sometimes lead to partial loss of remnant data.

The file system does not support safe writing through SRAM

If files are stored, modified or written on the Micro SD card from the user program, these files must always be stored with a fixed maximum size. Since changes in size and the simultaneous shutdown of the voltage supply can corrupt the file system, a later change in the file size is not allowed.

Data Breakpoint

This CPU does not support the data breakpoint is a feature.

Note on SRAM Behavior

Because the SRAM (remnant memory) is emulated via the microSD card, there are two different mechanisms for saving SRAM data to the microSD card:

1. Cyclic writing when data is changed (default)
2. Writing only in the event of PowerFail with a backup time buffered through the hardware (starting with version 01.02.195)

The advantage of cyclic writing is that in the event of a severe system crash, it's possible to reference an image of the SRAM data that with the standard settings, is a maximum of 1 minute older than the last change. With extensive use, the amount and frequency of SRAM data changes from the user program can have a massive effect on the microSD card lifespan.

Detailed information regarding the SRAM behavior and the corresponding settings can be found in the LASAL OS documentation, in the chapter "SRAM".

In the LASAL CLASS project, seldom changed value settings in retentive servers as well as RamEx and StringRam objects, can be converted to file storage. Should existing objects be converted from SRAM to File, the loader version 02.02.140 or higher and the RamEx and StringRam classes of the Tools library version 01.02.033 or higher must be used.

If the user program runs cyclic writing processes in files, the tool "Flash Media Lifetime Calculation" included in LASAL CLASS can be used to determine the effects of the operations mentioned above on the flash media. This allows the lifespan of the media to be calculated for different, configurable writing scenarios.

Recommended Shielding for VARAN

The real-time VARAN Ethernet bus system exhibits very robust characteristics in industrial environments. Through the use of IEEE 802.3 standard Ethernet physics, the potentials between an Ethernet line and sending/receiving components are separated. Messages to a bus participant are immediately repeated by the VARAN Manager in the event of an error. The shielding described below is principally recommended.

For applications in which the bus is run outside the control cabinet, the correct shielding is required. Especially when for structural reasons, the bus line must be placed next to strong electromagnetic interference. It is recommended to avoid placing VARAN bus lines parallel to power cables whenever possible.

SIGMATEK recommends the use of **CAT5e** industrial Ethernet bus cables.

For the shielding, an **S-FTP cable** should be used.

An S-FTP bus is a symmetric, multi-wire cable with unshielded pairs. For the total shielding, a combination of foil and braiding is used. A non-laminated variant is recommended.

The VARAN cable must be secured at a distance of 20 cm from the connector for protection against vibration!

1. Wiring from the Control Cabinet to an External VARAN Component

If the Ethernet lines are connected from a VARAN component to a VARAN node located outside the control cabinet, the shielding should be placed at the entry point to the control cabinet housing. All noise can then be dissipated before reaching the electronic components.

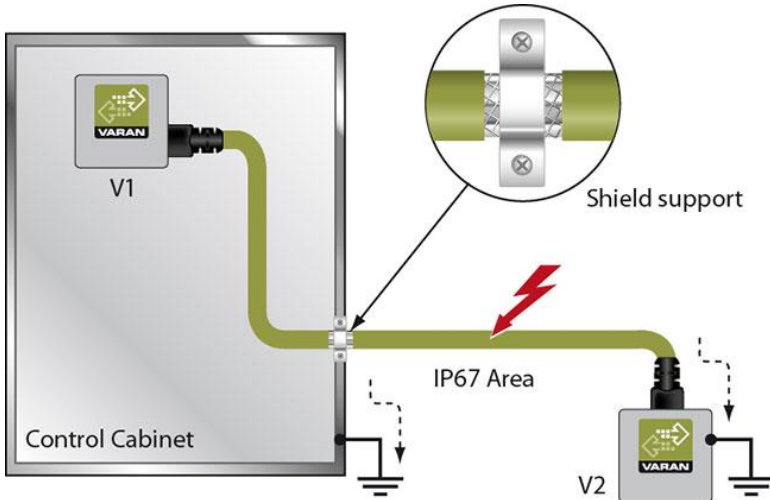

2. Wiring Outside of the Control Cabinet

If a VARAN bus cable must be placed outside of the control cabinet only, no additional shield connection is required. This requires that only IP67 modules and connectors be used. These components are very robust and noise resistant. The shielding for all sockets in IP67 modules are internally connected to common bus or electrically connected to the housing, whereby the deflection of voltage spikes does not flow through the electronics.

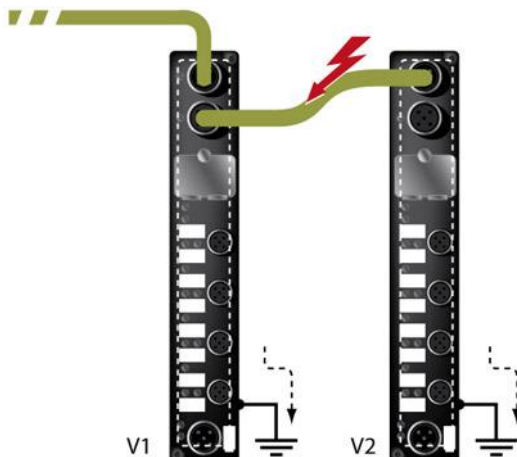

3. Shielding for Wiring Within the Control Cabinet

Sources of strong electromagnetic noise located within the control cabinet (drives, Transformers, etc.) can induce interference in a VARAN bus line. Voltage spikes are dissipated over the metallic housing of a RJ45 connector. Noise is conducted over the control cabinet without additional measures needed on the circuit board of electronic components. To avoid error sources with data exchange, it is recommended that shielding be placed before any electronic components in the control cabinet.

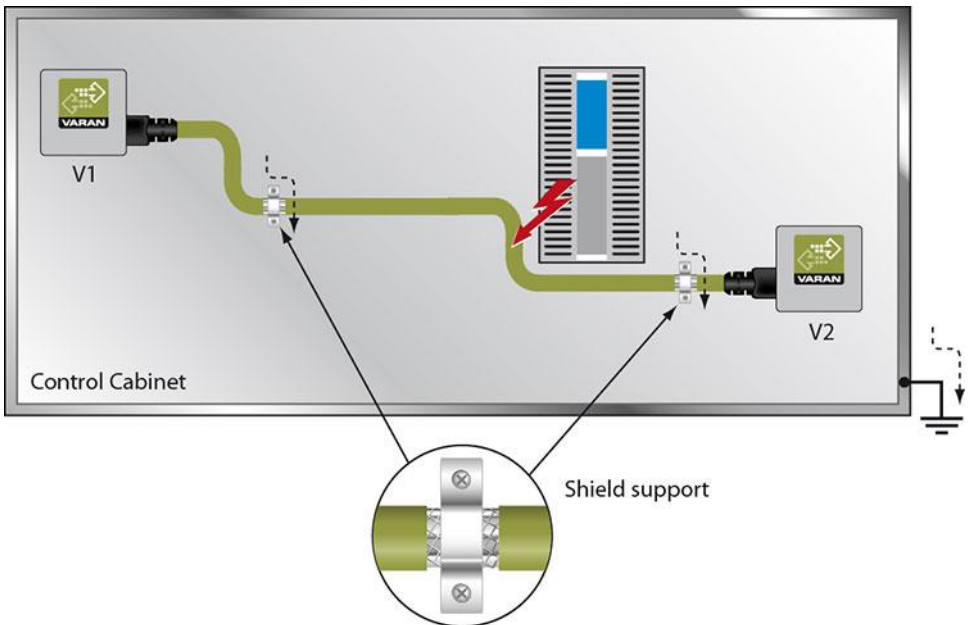

4. Connecting Noise-Generating Components

When connecting power lines to the bus that generate strong electromagnetic noise, the correct shielding is also important. The shielding should be placed before a power element (or group of power elements).

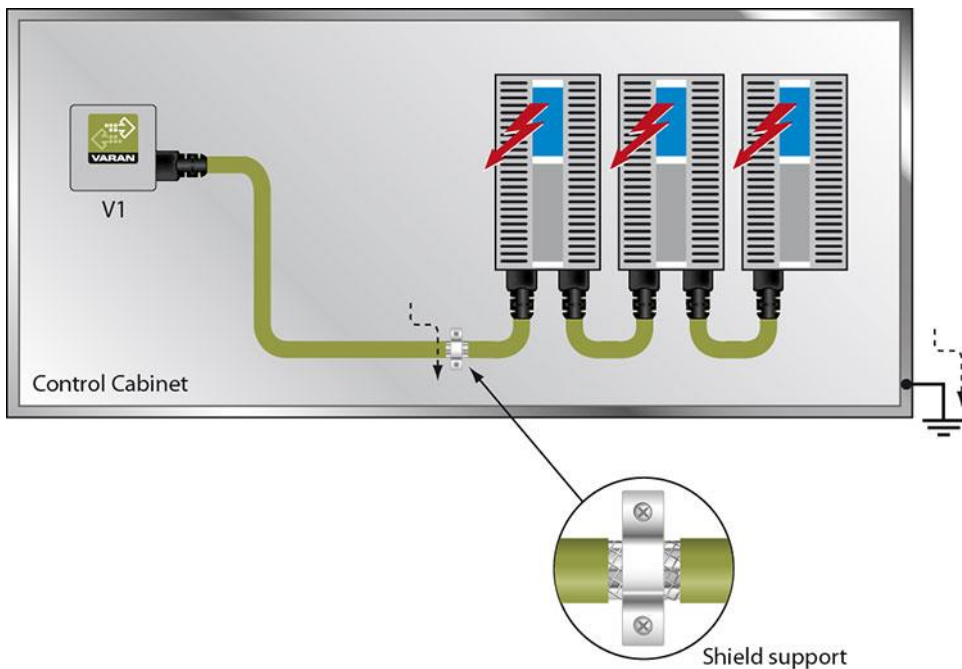

5. Shielding Between Two Control Cabinets

If two control cabinets must be connected over a VARAN bus, it is recommended that the shielding be located at the entry points of each cabinet. Noise is therefore prevented from reaching the electronic components in both cabinets.

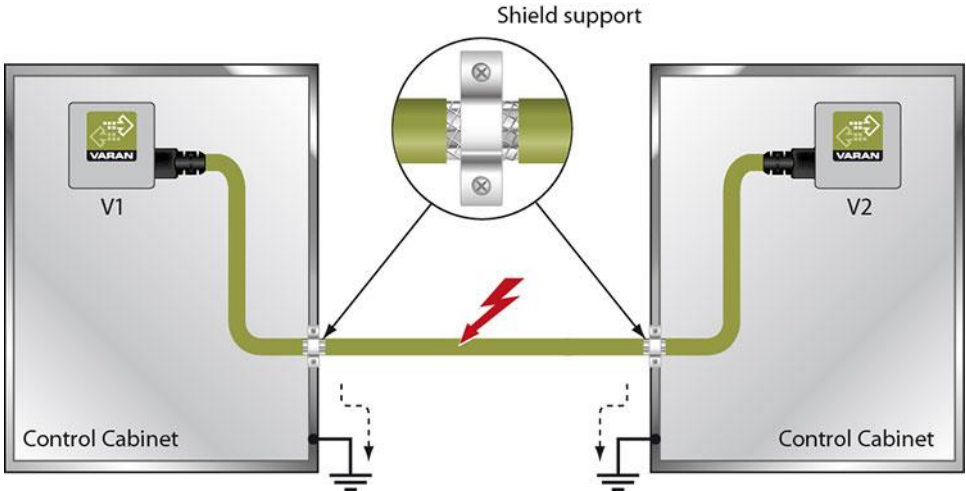

Cleaning the Touch Screen

CAUTION!

Before cleaning the touch screen, the terminal must first be turned off to avoid unintentionally triggering commands or functions!

ATTENTION!

Avant de nettoyer l'écran tactile, le terminal doit d'abord être éteint afin d'éviter un déclenchement involontaire des commandes!

The terminal's touch screen can only be cleaned with a soft, damp cloth. To dampen the cloth, a screen-cleaning solution such as an antistatic foam, water with detergent or alcohol should be used. First spray the cleaning fluid on the cloth and not directly on the terminal. The cleaning solution should not be allowed to reach the terminal electronics, for example, through the ventilation slots.

No erosive cleaning solutions, chemicals, abrasive cleansers or hard objects that can scratch or damage the touch screen may be used.

If the terminal comes in contact with toxic or erosive chemicals, clean the terminal immediately and with caution to prevent acid damage.

To ensure the optimal function of the terminal, the terminal should be cleaned regularly!

To extend the lifespan of the touch screen as much as possible, using the fingers to operate the terminal is recommended.

Pour garantir le fonctionnement optimal du terminal, le terminal doit être nettoyé régulièrement!

Pour prolonger la durée de vie de l'écran tactile on recommande d'utiliser les doigts pour l'opérer.

