

# PWS500S Installation Guide

## F-1 Introduction

The PWS500 is equipped with a 3.0" sized (160Hx80V) flat panel display and analog resistive touch screen. The IP 65 (NEMA 4) rated front panel seal and INDUSTRIAL GRADE touch screen make the product rugged and durable.

Pws-500S is a low cost yet powerful operator panel. It is an ideal choice for those PLC applications that have limited budget but still require an advanced and easy-to-operate man-machine interface. Thank to the use of solid state backlight, wide temperature LCD, durable mechanical switches, and anti-noise components in the 500S, you won't be surprised that the durability of the 500S will further reinforce your cost control. Functionally speaking, the 500S is as powerful as its sister, the PWS-700. Therefore, if you are already our precious customers, you would be happy that your other projects and machines with tight budgets can also enjoy the benefit of PWS Series products now.

This chapter describes how to install your Workstation in a panel, set its DIP switches, and make cables for its communications and printer ports.

## F-2 General Specification of PWS500S/520S

Item	PWS500S-LED	PWS520S-LED
Display Type	Monochrome STN LCD	
Display Color	Blue ; 4 gray levels	
Display Size	3.0" (diagonal); display area is 65x35mm	
Number of Pixels	160Hx80V; Number of 8x8 characters displayable is 20x10.	
Display Adjustment	Contrast adjustable by VR on the back	
Back Light	LED; Life time is approx. 100,000 hours	
Keypad	16 mechanical switches; Life of each switch is over 1 million activations; Membrane overlay is resistant to most solvents and chemicals.	
Input Power	24VDC±8% (22.5V-26V); Under 12W	
Export Digital IO	X	8 Input and 8 output points; 24VDC Source
Output Power	5VDC±5%; under 100mA	
Flash Memory	640K byte	
RAM	32K byte	
CPU	16-bit embedded controller	
Battery Backed Memory	X	
Communication Ports	RS232/RS422/RS485	
Front Panel Seal	IP65 / NEMA 4	
Operating Temperature	0~50°C	
Storage Temperature	-20~70°C	
Ambient Humidity	20-90% RH (non-condensing)	
Vibration Endurance	0.5mm displacement, 10-55Hz, 2 hours per X, Y, and Z-axis directions	
Shock Endurance	10G, 11ms three times in each direction of X, Y, and Z axes	
RF Emissions	CISPR 22, Class A	
Electrostatic Discharge	EN61000-4-2/1995	
RF Susceptibility	ENV50140/1993	
High Frequency Transients	EN61000-4-4/1995	
Weight	0.65 Kg; 173x105.5x51.79mm (WxHxT)	
Cooling	Natural cooling	

### F-3. Dimensions of PWS500S/520S

This section illustrates the dimensions of the Workstations themselves as well as the cutout dimensions(160.8x93.3mm). The unit of dimensions is millimeter. You should allow 10 cm (4") of clearance behind the workstation for cable connectors and 5 cm (2") above and below for airflow.

• Dimensions (unit:mm)

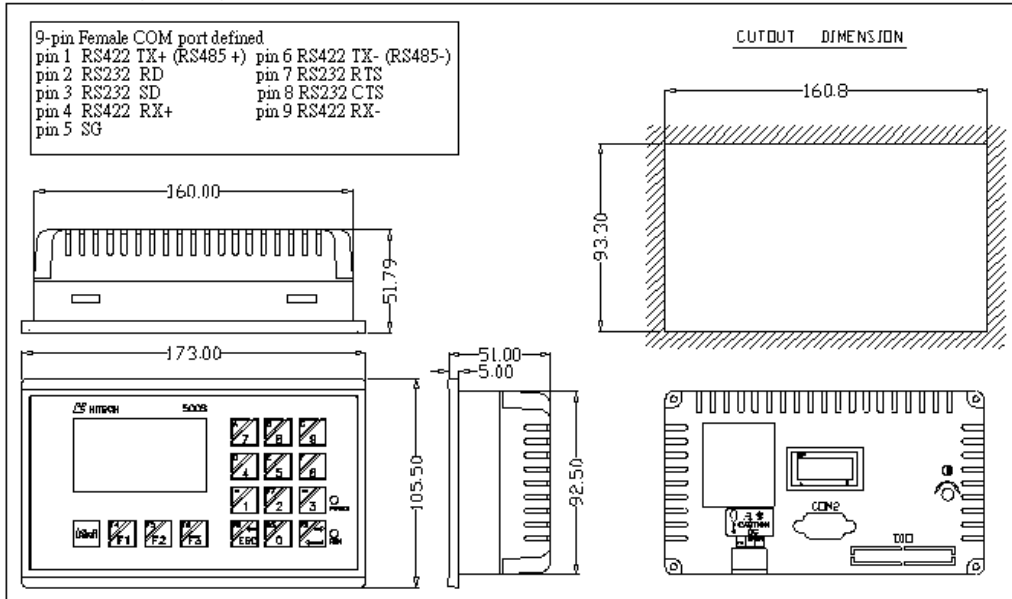

Everything for your HMI running



Touch.Keypad.Display  
 ✉ sales@vicpas.com  
 ☎ +86-15876525394

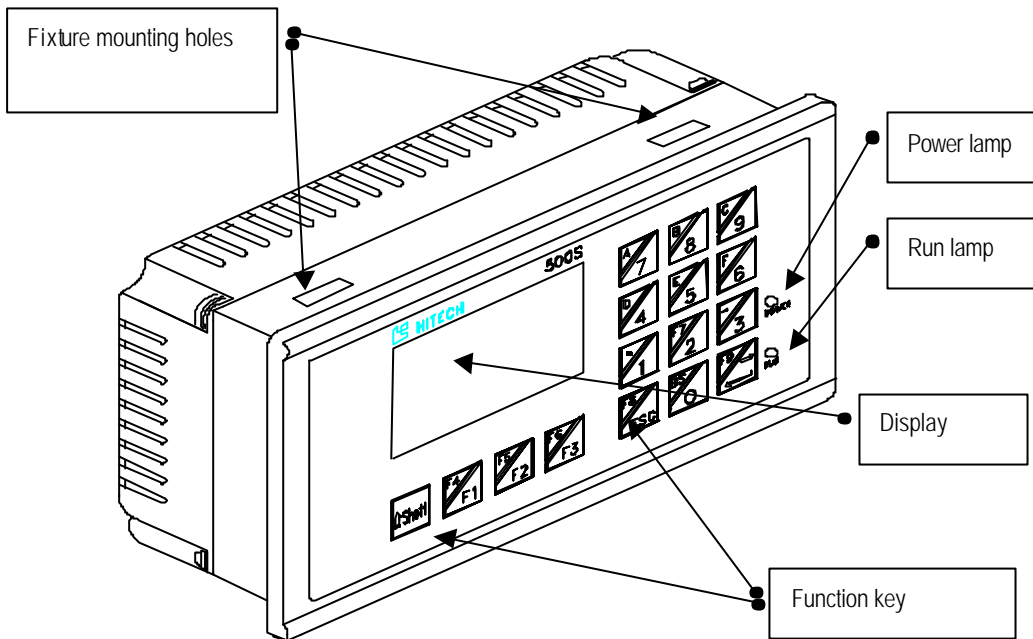

### Rear view

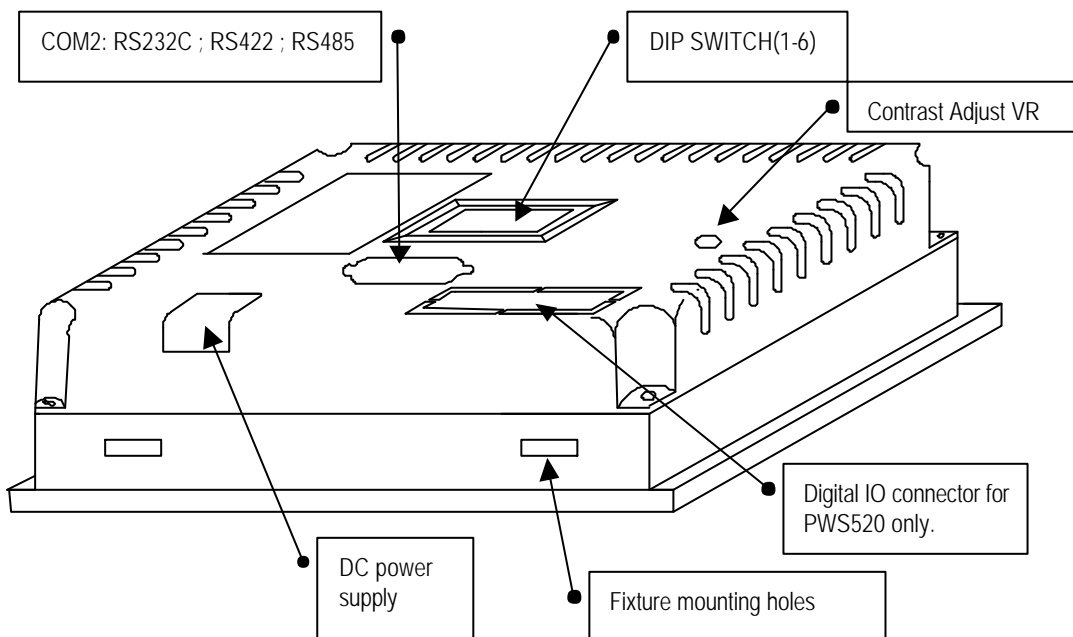

Everything for your HMI running



Touch.Keypad.Display  
 ✉ sales@vicpas.com  
 ☎ +86-15876525394

Cut out the mounting hole to match the dimensions shown below. Method of installation: Mount the PWS to the preserved hole from the front side. Attach the mounting brackets from behind, and fasten the screw of the brackets with a screwdriver.

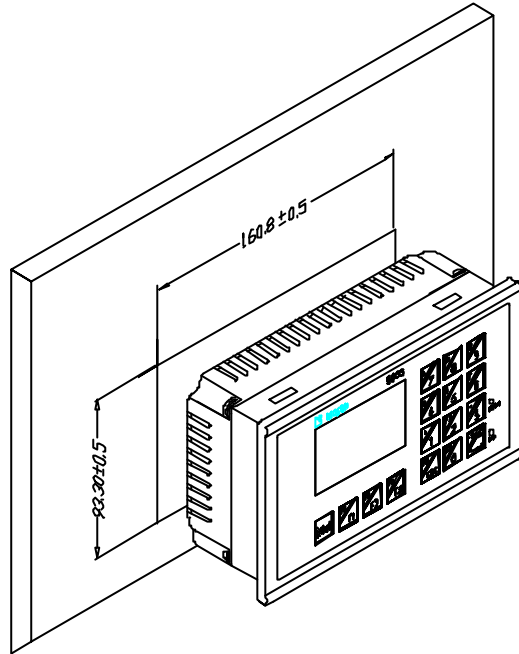

Everything for your HMI running



Touch.Keypad.Display  
✉ sales@vicpas.com  
☎ +86-15876525394

Insert the fixtures into mounting holes on the unit. Don't tighten the screws with too much force or it may cause a damage of the panel.

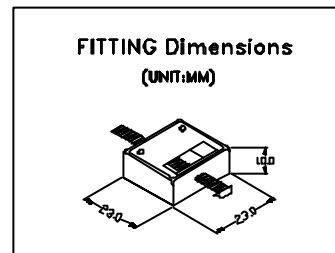
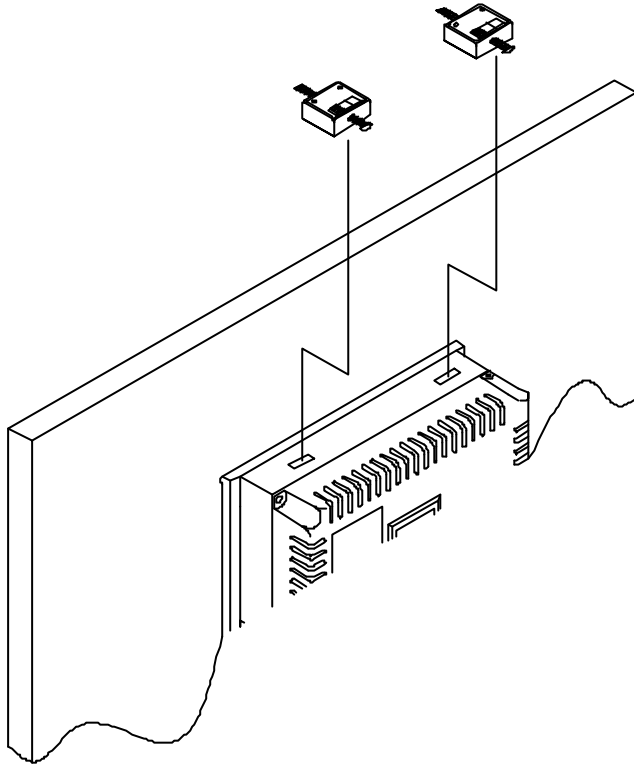

The unit shall be installed within the angle of 0 to 135 degrees as shown below.

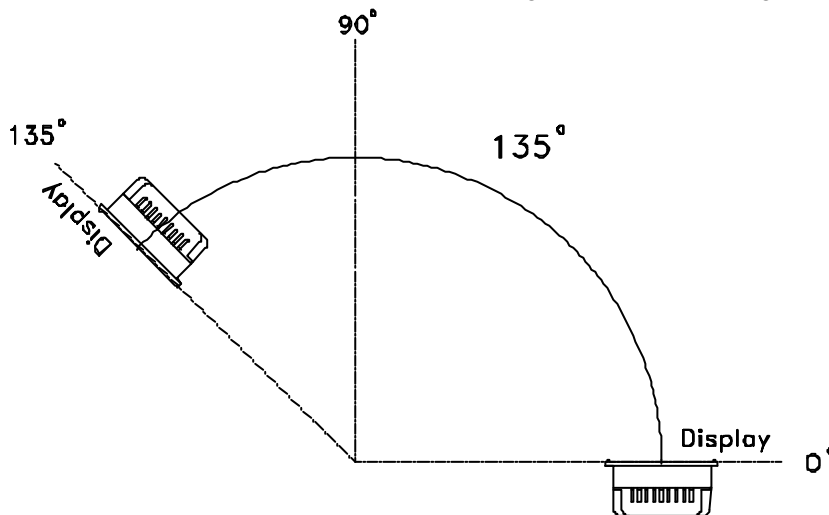

Everything for your HMI running



Touch.Keypad.Display  
✉ sales@vicpas.com  
☎ +86-15876525394

### F-3.1 Torque Specifications

After placing the Workstation in the cutout, you should tighten each nut to 0.07 newton-meters (10 inch/pounds) of torque. If you don't have a torque wrench, then try to tighten the nuts to compress the gasket to about 50% of its original thickness.

### F-4. Power Connector

The three-position power connector accepts 24VDC only. The unit's power consumption is shown in the following:

Item / Model	500S-LED	520S-LED
Power Consumption	24VDC±10% 12W	24VDC±10% 12W
Fuse Rating	0.5A	0.5A

Be sure to use all three terminals when connecting power. To make a connection, strip about 0.64 cm (1/4") of insulation, turn the screw counter-clockwise until the gap is wide open, insert the wire all the way in, and turn the screw clockwise until it's tight.

### F-4.1 Electrical Grounding

You must make sure that your Workstation is properly connected to earth ground, to prevent it from radiating radio frequency noise. You should also ensure that the Workstation is on the same ground as any other equipment connected to its communications ports.

If you connect a communications cable to your unit after static electricity has built up or when the Workstation and the other device are on different grounds, the resulting discharge could damage the electronics in either device.

Everything for your HMI running



Touch.Keypad.Display  
✉ sales@vicpas.com  
☎ +86-15876525394

## F-5. Calibrating membrane function switch

To calibrate the membrane function switch, Set DIP switches SW3 and SW4 of the PWS500S to off. After power on, the PWS displays the following pattern.  
Figure 1

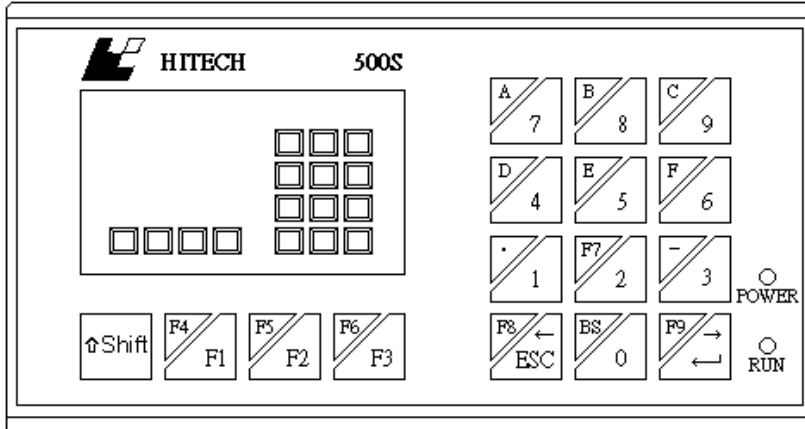

### F-5.1 Common Keys, Auxiliary Keys, and External Keys

There are three kinds of keys you can configure for the 500S with the ADP3:

- 1) **Common Keys** - A common key is used to activate a designated function no matter what the current screen is. For example, you can press the key K1 to return to the screen 1 whenever you want if the key is configured as a common key that goes to screen 1. To configure common keys for your application, select Common Keys on the Application sub-menu of the ADP3 as shown in the Figure 2.

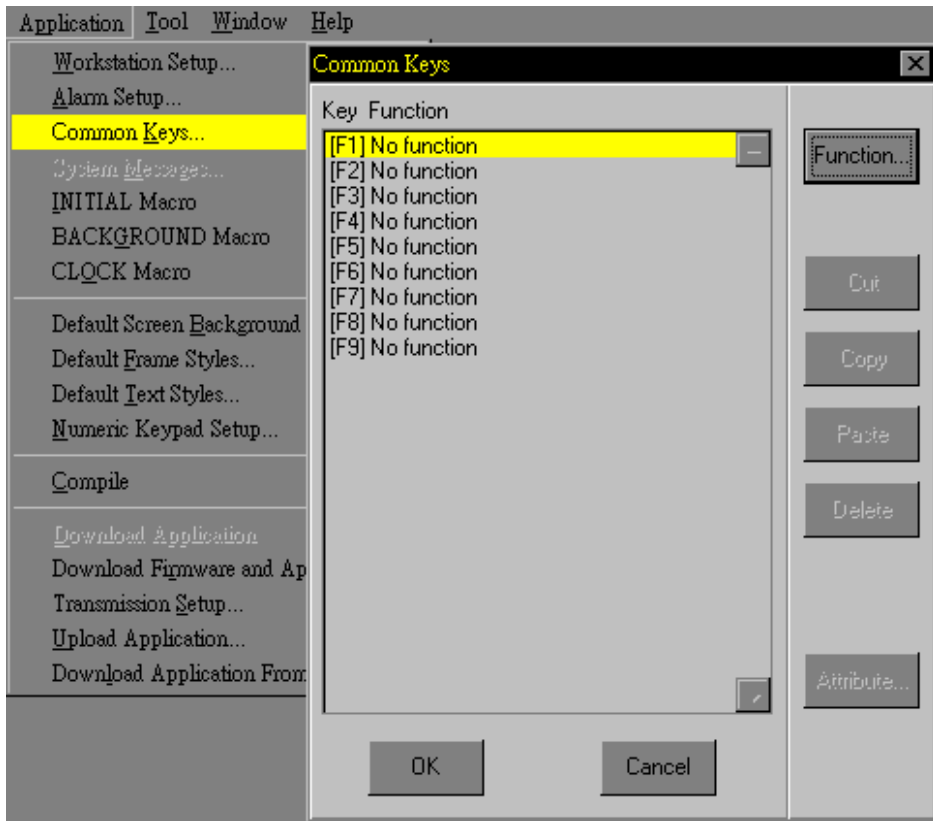

Figure 2

- 2) **Auxiliary Keys** - A screen can have a number of auxiliary keys. The auxiliary keys of a screen are available for use only when that screen is the current screen. To configure auxiliary keys for a screen, select that screen first and then select Auxiliary Keys on the Screen sub-menu.
  
- 3) **External Keys** – For a screen object requiring a real key to activate its function, you need to assign an external key switch as its external key when you configure that object. However, it is optional to assign an external key for a Numeric Entry, because a Numeric Entry can also be selected by reserved arrow keys.



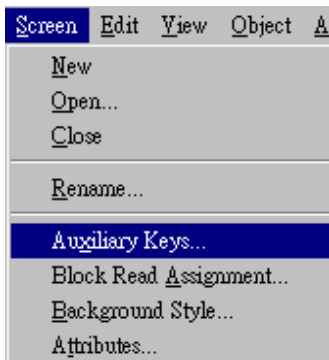

Figure 3

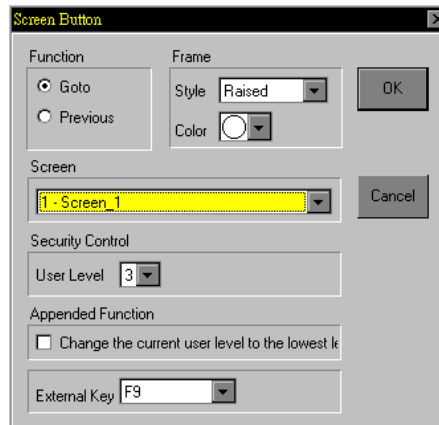

Figure 4

## F-6 Setting of DIP Switches

There are ten DIP switches that you can access through the back cover. The purposes of these switches are stated in the following:

SW1	System Menu
ON	The Workstation displays System Menu after it gets a legal password or after power-on self-test if SW6 is off.
OFF	The Workstation doesnot display System Menu.

SW2	Default User Level
ON	The default user level is one if the Workstation requires no password to start its operation.
OFF	The default user level is three if the Workstation requires no password to start its operation.

SW4	SW3	Running Mode
ON	ON	Runs user application.
ON	OFF	Off-line display screen did not link with PLC
OFF	ON	Runs bench test program.
OFF	OFF	Runs burn-in test program.

SW5	COM2 Port
ON	Enable RS485 circuitry of the COM2.
OFF	Enable RS422 circuitry of the COM2.

SW6	Password
ON	The Workstation asks the operator to enter a password after power-on self-test.
OFF	No password is required to start the Workstation.

## F-7 Self Test

After power is applied, the Workstation runs a self-test that checks its hardware. After each test, the Workstation displays the result as shown in the following example. The version number of ROM BIOS refers to the EPROM chips, which will likely never change.

PLC Workstation BIOS Version 1.1 Hitech ELEC CORP.	
Type = Mono STN LCD	
SYS RAM Size	..... 32KB
Video RAM Size	..... 32KB
F/W Size	..... 128KB
User Mem Size	..... 640KB

PLC Workstation BIOS Version 1.1 Hitech ELEC CORP.	
Working RAM Test	..... P
BIOS ROM CheckSum	..... P
F/W CheckSum	..... P
A/P CheckSum	..... P

PLC Workstation BIOS Version 1.1 Hitech ELEC CORP.	
Com. Port Test	..... P
SW(6.1) = 0X1111	

If you have never configured your Workstation, the self-test may report a failure of the real time clock. If this happens, configure as described in section 10. If you have never downloaded an application to the Workstation, the self-test may report a problem in the flash chips. You can ignore these errors. If you have interrupted a download to the Workstation by switching off the power, disconnect the communication cable, or click cancel button in the ADP3 while a download is in progress, the self-test may report a problem in the Firmware Checksum or Application Checksum. You can ignore these errors and try to download again.

If there are any items of the self-test the Workstation doesn't pass, the message **'System error is detected! Press screen to continue.'** appears. The Workstation continues its operation after you press **screen**

## F-8. System Menu

After the user level is determined by a password or by the default, the Workstation displays System Menu if the DIP switch No.1 is on; If DIP switch 7 is off, the Workstation starts running your application immediately.

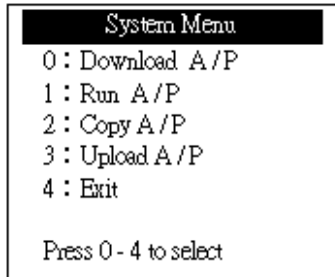

The buttons on the System Menu are summarized in the following:

Button	Function	User Level
<b>0:Download A/P</b>	Allows you to download an application to the Workstation from a PC or another Workstation.	1
<b>1:Run A/P</b>	Starts running your application.	1-3
<b>2:Copy A/P</b>	Allows you to copy the application in the Workstation to another Workstation.	1
<b>3:Upload A/P</b>	Allows you to upload the application in the Workstation to a PC.	1
<b>4:Exit</b>	Starts from the self-test again.	1-3

## F-9. Downloading Application

To make the Workstation ready for receiving downloaded application, press the Download Application button on System Menu. The Workstation displays the message "Waiting for downloading..." when it is ready. After downloading, the System Menu is active again.

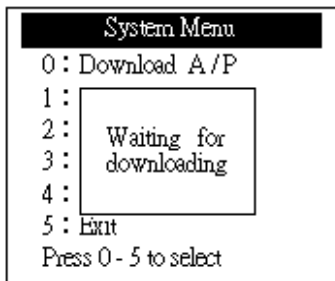

You should have a cable with the following connection for the download.

PWS to PC's 9-pin connector

HMI-COM port		PC-port RS232C	
9-pin male	CABLE	9-pin female	
RXD 2	_____	3	TXD
TXD 3	_____	2	RXD
GND 5	_____	5	GND
RTS 7	_____	8	CTS
CTS 8	_____	7	RTS



Warning: To avoid electric shock, be sure to switch off the power when connecting the communication/download cable to the PWS unit.

## F-10. Setting Operating Parameters

You can use Communication Parameter dialog box of ADP3 to set the parameters for the communications between your PWS500S and PLC. The parameters set in ADP3 is transmitted to the Workstation along with all other data when you download an application. The Workstation uses these parameters for PLC communications, if the DIP switch No.3 and No.4 are on.

To get Communication Parameters dialog box, click Communications button in Workstation Setup dialog box. The Communication Parameter dialog box appears figure 5 with the following options:

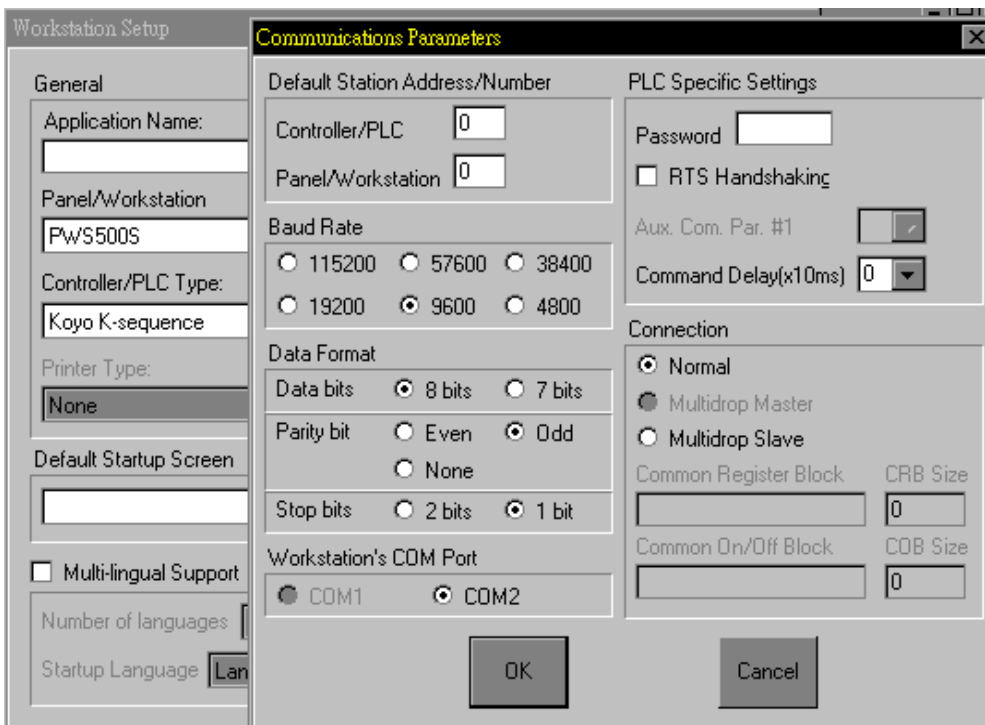

Figure 5

## F-11. Serial Communication Port2 (COM2 9pin female)

COM 2 is a serial port that supports RS-232, RS-422, and RS-485 operation. The pin assignments of the port are listed in the following table:

Pin	Function
1	RS-422 TX+ (RS485+)
2	RS-232 RXD
3	RS-232 TXD
4	RS-422 RX+
5	Signal ground
6	RS-422 TX- (RS485-)
7	RS-232 RTS
8*	RS-232 CTS
9	RS-422 RX-

## F-12. Password and User Level

The 500S stores passwords in its Flash EPROM. A password has eight numeric characters. When you register a password, you must specify the user level associative with that password. The user level of a password determines the privilege of the user who enters that password to start the operation of the 500S. When a user wants to use the function of the System Menu, change to another screen, or make change to a PLC location, the 500S checks the user's user level. There are three user levels: level 1, level 2, and level 3. Level 1 users have the highest privilege and Level 3 users have the lowest privilege.

### F-12.1 Registering Passwords

You can register up to six passwords for your application in ADP3. To register passwords and their associated user level, click Password button on the Workstation Setup dialog box. The ADP3 displays the Password Table as shown in the following figure. You can enter passwords as well as select the user level for them. The password data are part of the application data.

#	Password	User Level
1	22183600	1
2	12345678	2
3	12131415	3
4	00000000	3
5	00000000	3
6	00000000	3

Therefore, remember to compile your application and download it to the 500S when you make any changes to the password table. The default passwords are 00000000, 00000000, 00000000, 00000000, 00000000, and 00000000. The default user level is level 1.

### F-12.2 Setting the Lowest User Level

You are able to set the current user level of the 500S to level 3 by pressing an Action button that is assigned the function of “Set Lowest User Level.”

### F-12.3 Displaying Passwords

To display the passwords of your application on the 500S, you have to create an Action button on a screen and assign the function "Display Password Table" to that button. The 500S displays the password table as the example shown below, when a level 1 user presses and releases an Action button that is assigned the function of "Display Password Table."

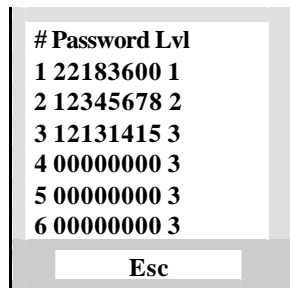

#	Password	Lvl
1	22183600	1
2	12345678	2
3	12131415	3
4	00000000	3
5	00000000	3
6	00000000	3

Esc

### F-12.4 Reentering a Password

When the 500S is running the user application, you can enter a password to change the current user level by pressing an Action button that is assigned the function of “Reenter Password.” To cancel the input of a new password, press [Esc].



Figure 4 Entering a password

Note that the default user level is 1 after the power-on self-test if the DIP switch SW2 is set to on; the default user level is 3 if the SW2 is set to off.

When a screen object requiring a certain user level is activated and the current user level is higher than the specified user level with that screen object, the 500S automatically displays a box to let you enter a new password. This is a chance to change the current user level. The screen object proceeds to performs its function if a valid password with qualified user level is entered; otherwise, the 500S keeps on asking for a password or cancel the operation

### F-12.5 Entering Password

After the self-test, if the DIP switch No.6 is on, the Workstation displays a keypad to prompt you to enter a password. If DIP switch No.6 is off, the Workstation doesn't ask you to enter a password and the default user level is 1 after the power-on self-test if the DIP switch SW2 is set to on; the default user level is 3 if the SW2 is set to off.

If a password is required, the Workstation doesn't continue its operation until a legal password is entered.

### F-13. Adjusting Display Contrast

You can adjust the contrast of the STN LCD at any time the Workstation is running your application. The user can adjust the LCD contrast by screw the VR from rear cover.

### F-14. PWS520S-LED digital input and output specification

Input specification		DC input
Nominal voltage		24 V DC
Input voltage		20 V DC~28 V DC
Input current		5mA (when input and common terminals are short circuited)
Operational Specification	ON	Resistance 300 . or less
	OFF	Resistance 200k . or more
Input delay Time	ON . OFF	20 .s or less
	OFF . ON	20 .s or less
No. of input points		8 input
Isolation method		Photocoupler
Current consumption (average)		50 mA

Output specification		DC output
Nominal voltage		24 V DC
Output voltage		12 V DC~28 V DC
No. of output points		8 points
Max. load Current		0.8A
Max. output delay Time	ON . OFF	50 .s
	OFF . ON	50 .s
Min. load current		10mA (24 V DC)
Max. rush current		0.3A(20ms)
Isolation method		Photocoupler

PWS520S-LED Digital IO with 20pin latch/ejector header pin assignment

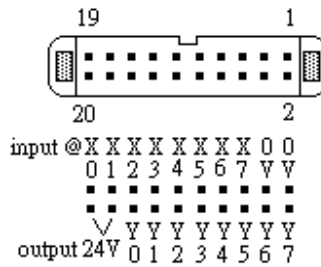
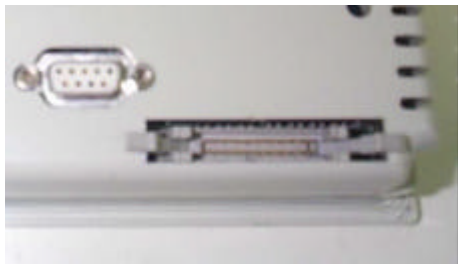

Circuit diagram: Input

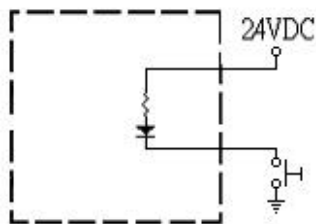

Circuit diagram: Output

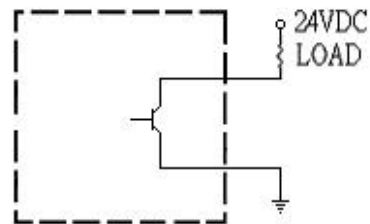

**Cautions**

If this product is used in a home, radio-wave interference may occur with other devices. In the case that it does occur, the user is requested to try a variety of remedies to solve the problem.

**Package Contents**

The following items are included in the package. Before using, please ensure everything is there.

? **PWS unit x1**

PWS500S-LED



PWS520S-LED



? **Installation screw nuts x4**

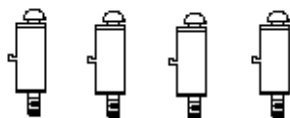

Everything for your HMI running



Touch. Keypad. Display  
 sales@vicpas.com  
 +86-15876525394