

---

**EXTER T100sr**

Installation Manual

English

MAEN965, 2008-11

Everything for your HMI running



Touch.Keypad.Display  
✉ sales@vicpas.com  
☎ +86-15876525394

## Installation manual for the EXTER series operator panels

# Foreword

The EXTER sun-readable operator panel is particularly suitable for round-the-clock use where reliable, robust and user-friendly HMI solutions are needed to maintain operations at all hours and throughout diverse light conditions. EXTER sun-readable provides clear and accurate information even in conditions of bright daylight glare.

All operator panels in the EXTER series are developed to satisfy the demands of human-machine communication. Built-in functions such as displaying and controlling text, dynamic indication, time channels, alarm and recipe handling are included.

The operator panel works primarily in an object-oriented way, making it easy to understand and use. Configuration is carried out on a PC using Information Designer configuration tool. The project can then be transferred and stored in the operator panel itself.

Various types of automation equipment such PLCs, servos or drives can be connected to the EXTER sun-readable operator panel. In this manual, the term “the controller” refers to the connected equipment.

This manual explains how to install the operator panel. Please refer to the reference manual for further information.

© Beijer Electronics AB, MAEN965, 2008-11

The information in this document is subject to change without notice and is provided as available at the time of printing. Beijer Electronics AB reserves the right to change any information without updating this publication. Beijer Electronics AB assumes no responsibility for any errors that may appear in this document. Read the entire installation manual prior to installing and using this equipment.

Only qualified personnel may install, operate or repair this equipment. Beijer Electronics AB is not responsible for modified, altered or renovated equipment.

Because the equipment has a wide range of applications, users must acquire the appropriate knowledge to use the equipment properly in their specific applications.

Persons responsible for the application and the equipment must themselves ensure that each application is in compliance with all relevant requirements, standards and legislation in respect to configuration and safety.

Only parts and accessories manufactured according to specifications set by Beijer Electronics AB may be used. BEIJER ELECTRONICS AB SHALL NOT BE LIABLE TO ANYONE FOR ANY DIRECT, INDIRECT, SPECIAL, INCIDENTAL OR CONSEQUENTIAL DAMAGES RESULTING FROM THE INSTALLATION, USE OR REPAIR OF THIS EQUIPMENT, WHETHER ARISING IN TORT, CONTRACT, OR OTHERWISE. BUYER'S SOLE REMEDY SHALL BE THE REPAIR, REPLACEMENT, OR REFUND OF PURCHASE PRICE, AND THE CHOICE OF THE APPLICABLE REMEDY SHALL BE AT THE SOLE DISCRETION OF BEIJER ELECTRONICS AB.

Everything for your HMI running

Beijer Electronics, MAEN965



Touch. Keypad. Display

✉ sales@vicpas.com

☎ +86-15876525394

# Table of Contents

<b>1 Safety Precautions</b> .....	<b>5</b>
1.1 UL and cUL Installation .....	5
1.2 General .....	6
1.3 During Installation.....	6
1.4 During Use .....	7
1.5 Service and Maintenance.....	7
1.6 Dismantling and Scrapping.....	7
<b>2 Installation</b> .....	<b>9</b>
2.1 Space Requirements .....	9
2.2 Installation Process.....	9
2.2.1 Mode Switches .....	11
2.2.2 Connections to the Controller .....	11
2.2.3 Other Connections and Peripherals .....	11
<b>3 Technical Data</b> .....	<b>13</b>
<b>4 Chemical Resistance</b> .....	<b>15</b>
4.1 Metal Casing.....	15
4.2 Touch Screen and Overlay .....	16
4.2.1 Autotex XE.....	16
4.2.2 Touch Screen Surface .....	16
<b>5 Operator Panel Drawings</b> .....	<b>17</b>
5.1 Communication Ports.....	17
5.2 EXTER T100 Outline .....	18
<b>6 Additional Installation Tips</b> .....	<b>19</b>
6.1 Grounding the Operator Panel .....	19
6.2 Ethernet Connection in the Panel .....	20
6.3 To Achieve Better EMC Protection .....	21
6.4 Ambient Temperature.....	22
6.5 Safety .....	23
6.6 Galvanic Isolation .....	24
6.7 Cable and Bus Termination RS485.....	25

Everything for your HMI running



Beijer Electronics, MAEN965

Touch.Keypad.Display

✉ sales@vicpas.com

☎ +86-15876525394

# 1 Safety Precautions

Both the installer and the owner and/or operator of the operator panel must read and understand this installation manual.

## 1.1 UL and cUL Installation

- This equipment is suitable for use in Class I, Division 2, Groups A, B, C and D OR non-hazardous locations only. [Combinations of equipment in your system are subject to investigation by the local Authority Having Jurisdiction at the time of installation.]
- Maximum ambient temperature 40 °C when mounted horizontal or 50 °C when mounted vertical.
- WARNING – EXPLOSION HAZARD – Do not disconnect equipment unless power has been removed or the area is known to be non-hazardous.
- For Canada also AVERTISSEMENT – RISQUE D’EXPLOSION – AVANT DE DECONNECTER L’EQUIPEMENT, COUPER LE COURANT OU S’ASSURER QUE L’EMPLACEMENT EST DESIGNE NON DANGEREUX.
- WARNING – EXPLOSION HAZARD - Substitution of components may impair suitability for Class I, Division 2.
- For Canada also AVERTISSEMENT – RISQUE D’EXPLOSION – LA SUBSTITUTION DE COMPOSANTS PEUT RENDRE CE MATERIEL INACCEPTABLE POUR LES EMBLEMES DE CLASSE I, DIVISION 2.
- WARNING – EXPLOSION HAZARD – only UL and cUL approved expansion units are allowed to be connected to the port designated “EXPANSION”. At the moment there are no such units evaluated or allowed.
- WARNING – EXPLOSION HAZARD - Do not replace expansion unit unless power has been switched off or the area is known to be non-hazardous.
- This product contains battery, this must only be changed in an area known to be non-hazardous. Permitted types are shown in the section [Technical Data](#).
- For use on a flat surface of a type 4X enclosure indoor use only.
- To make wiring connections to the power supply connector, use an AWG 28-12 cable and a tightening torque of min. 0.5 Nm.

## 1.2 General

- Read the safety precautions carefully.
- Check the delivery for transportation damage. If damage is found, notify the supplier as soon as possible.
- Do not use the operator panel in an environment with high explosive hazards.
- The supplier is not responsible for modified, altered or reconstructed equipment.
- Use only parts and accessories manufactured according to specifications of the supplier.
- Read the installation and operating instructions carefully before installing, using or repairing the operator panel.
- Never allow fluids, metal filings or wiring debris to enter any openings in the operator panel. This may cause fire or electrical shock.
- Only qualified personnel may operate the operator panel.
- Storing the operator panel where the temperature is lower/higher than recommended in this manual can cause the LCD display liquid to congeal/become isotopic.
- The LCD display liquid contains a powerful irritant. In case of skin contact, wash immediately with plenty of water. In case of eye contact, hold the eye open, flush with plenty of water and get medical attention.
- The figures in this manual serves an illustrative purpose. Because of the many variables associated with any particular installation, the supplier cannot assume responsibility for actual use based on the figures.
- The supplier neither guarantees that the operator panel is suitable for your particular application, nor assumes responsibility for your product design, installation or operation.

## 1.3 During Installation

- The operator panel is designed for stationary installation on a plane surface, where the following conditions are fulfilled:
  - no high explosive risks
  - no strong magnetic fields
  - no direct sunlight
  - no large, sudden temperature changes
- Install the product according to the accompanying installation instructions.
- Ground the product according to the accompanying installation instructions.
- Only qualified personnel may install the operator panel.
- Separate the high voltage, signal and supply cables.
- Make sure that the voltage and polarity of the power source is correct before connecting the product to the power outlet.
- Peripheral equipment must be appropriate for the application and location.

## 1.4 During Use

- Keep the operator panel clean.
- Emergency stop and other safety functions may not be controlled from the operator panel.
- Do not use too much force or sharp objects when touching the keys, touch screen etc.

## 1.5 Service and Maintenance

- Only qualified personnel should carry out repairs.
- The agreed warranty applies.
- Before carrying out any cleaning or maintenance operations, disconnect the equipment from the electrical supply.
- Clean the display and surrounding front cover with a soft cloth and mild detergent.
- Replacing the battery incorrectly may result in explosion. Only use batteries recommended by the supplier.

## 1.6 Dismantling and Scrapping

- The operator panel or parts thereof shall be recycled according to local regulations.
- The following components contain substances that might be hazardous to health and the environment: lithium battery, electrolytic capacitor and display.

Everything for your HMI running



## 2 Installation

### 2.1 Space Requirements

- Installation plate thickness: 1.5 - 9.0 mm (0.06 - 0.35 inch)
- Space requirements when installing the operator panel:

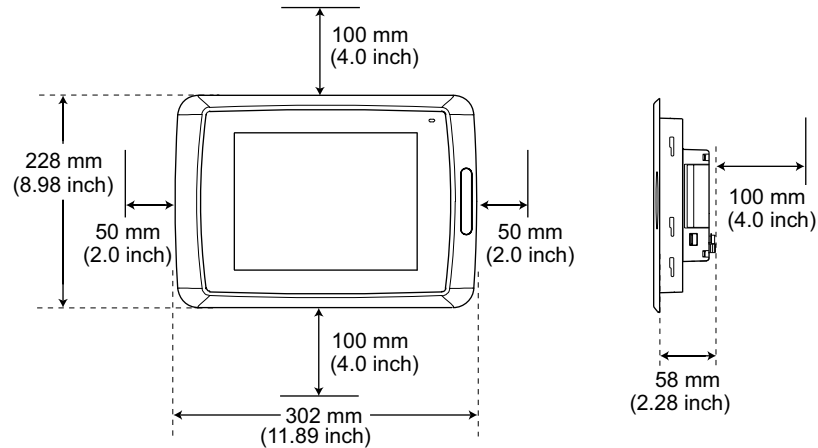

#### Caution

The openings on the enclosure are for air convection. Do not cover these openings.

### 2.2 Installation Process

1. Unpack and check the delivery. If damage is found, notify the supplier.

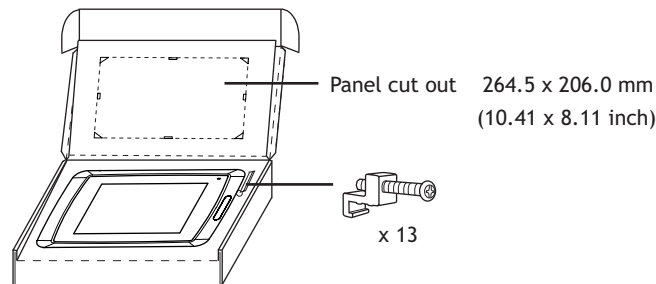

#### Note:

Place the operator panel on a stable surface during installation. Dropping it or letting it fall may cause damage.

2. Place the panel cut out where the operator panel is to be situated, draw along the outer sides of the holes and cut according to the markings.

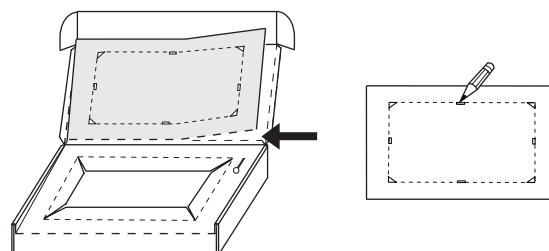

Everything for your HMI running

- Secure the operator panel in position, using all the fastening holes and the provided brackets and screws:

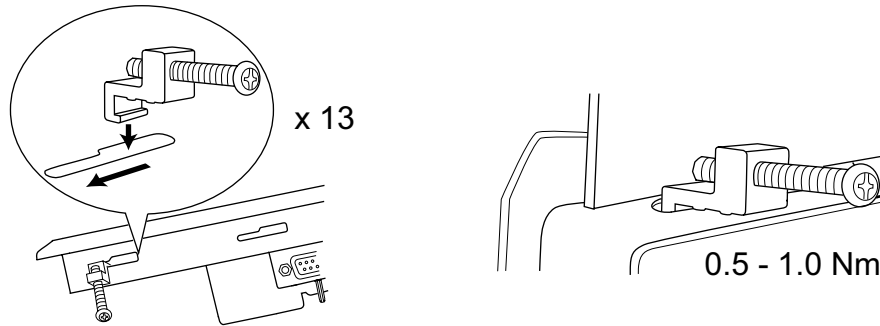

- Connect the cables in the specified order.

- Caution**

Ensure that the operator panel and the controller system have the same electrical grounding (reference voltage level), otherwise errors in communication may occur.
- Use an M5 screw and a grounding conductor (as short as possible) with a cross-section of minimum  $2.5 \text{ mm}^2$ .
- Caution**

  - Use only shielded communication cables.
  - Separate high voltage cables from signal and supply cables.
- Caution**

  - The operator panel must be brought to ambient temperature before it is started up. If condensation forms, ensure that the operator panel is dry before connecting it to the power outlet.
  - Ensure that the voltage and polarity of the power source is correct.

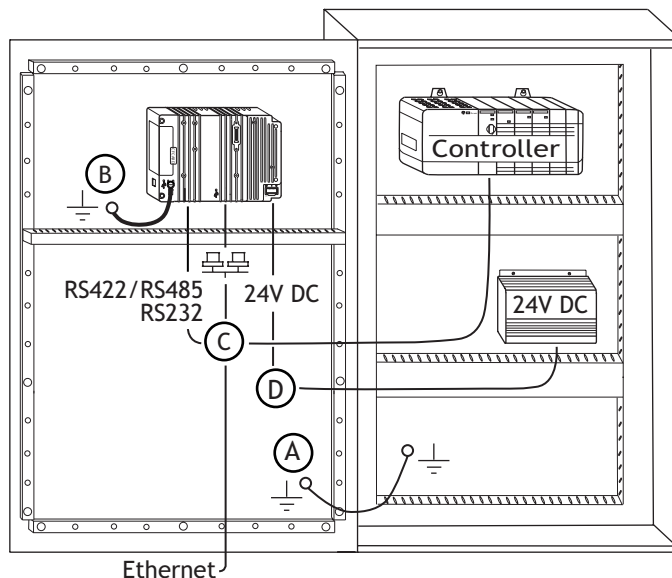

- Carefully remove the laminated film, if applicable, over the operator panel display, to avoid static electricity that could damage the panel.

## 2.2.1 Mode Switches

All mode switches must be in OFF position during operator panel use.

The mode switches should not be touched unless by qualified personell.

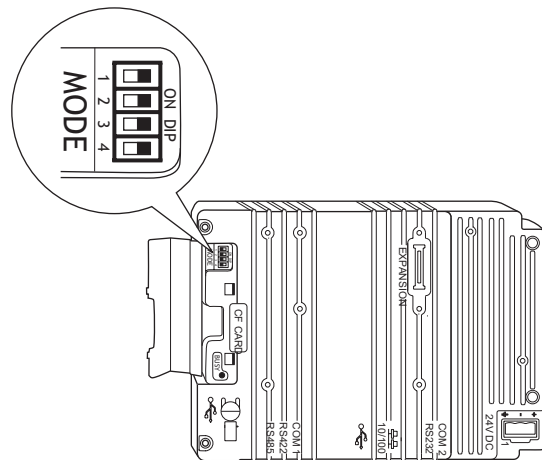

## 2.2.2 Connections to the Controller

For information about the cables to be used when connecting the operator panel to the controller, please refer to the help file for the driver in question.

## 2.2.3 Other Connections and Peripherals

- Cables, peripheral equipment and accessories must be suitable for the application and its environment. For further details or recommendations, please refer to the supplier.



### Caution

When using a compact flash card, do not remove the card when the busy indicator is illuminated.

Everything for your HMI running

### 3 Technical Data

Parameter	EXTER T100sr
Front panel, W x H x D	302 x 228 x 6 mm
Mounting depth	58 mm (158 mm including clearance)
Front panel seal	IP 66
Rear panel seal	IP 20
Keyboard material/ Front panel	Touch screen: Polyester on glass, 2 million finger touch operations. Overlay: Autotex XE *.
Reverse side material	Powder-coated aluminum
Weight	2.1 kg
Serial port RS422/ RS485	25-pin D-sub contact, chassis-mounted female with standard locking screws 4-40 UNC.
Serial port RS232C	9-pin D-sub contact, male with standard locking screws 4-40 UNC.
Ethernet	Shielded RJ 45
USB	Host type A (USB 1.1), max output current 500mA Device type B (USB 1.1)
CF-slot	Compact flash, type I and II
Flash memory for application	12 MB (incl. fonts)
Real time clock	±20 PPM + error because of ambient temperature and supply voltage. Total maximum error: 1 min/month at 25 °C Temperature coefficient: 0.004 ppm/°C <sup>2</sup>
Real time clock battery	CR2450 (UL and cUL: Sanyo or Panasonic) Minimum lifetime: 3 years
Power consumption at rated voltage	Normal: 0.5 A Maximum: 1.0 A
Display	TFT-LCD. 800 x 600 pixels, 64K color. CCFL backlight lifetime at the ambient temperature of +25 °C: >50,000 h.
Active area of display, W x H	211.2 x 158.4 mm
Fuse	Internal DC fuse, 3.15 AT, 5 x 20 mm
Power supply	+24V DC (20 - 30V DC). Power supply connector. CE: The power supply must conform with the requirements according to IEC 60950 and IEC 61558-2-4. UL and cUL: The power supply must conform with the requirements for class II power supplies.
Ambient temperature	Vertical installation: 0 ° to +50 °C Horizontal installation: 0 ° to +40 °C
Storage temperature	-20 ° to +70 °C
Relative humidity	5 - 85 % non-condensed
Approvals	Please refer to <a href="http://www.beijerelectronics.com">www.beijerelectronics.com</a> for information.

\* See section [Chemical Resistance](#) for more information.

Everything for your HMI running

## 4 Chemical Resistance

### 4.1 Metal Casing

The frame and casing material is powder-coated aluminum. This powder paint withstands exposure to the following chemicals without visible change:

Acetic acid 10%	Phosphoric acid 4%
Citric acid 10%	Phosphoric acid 10%
Diesel	Sea water
Distilled water	Sodium chloride 2%
Edible oil	Sodium chloride 20%
Fuel oil	Sulphuric acid 20%
Hydrogen peroxide 3%	Tap water

The powder paint shows limited resistance to the following chemicals at room temperature:

Butanol	Nitric acid 3%
Hydrochloric acid 5%	Nitric acid 10%
Isopropyl alcohol	Phosphoric acid 43%
Na-hypochlorite 10%	Turpentine

**Note:**

If exposure to any of the above chemicals is demanded, it is recommended to first test the chemical on an "invisible" spot of the metal casing.

The powder paint shows little or no resistance to the following chemicals at room temperature:

Acetic acid, conc.	Methyl-ethyl ketone	Toluene
Acetone	Nitric acid 30%	Trichlorethylene
Ammonia 5%	Phenol	Xylene
Ammonia, conc.	Sodium hydroxide 5%	97 octan unleaded petrol
Ethyl acetate	Sodium hydroxide 30%	98 octan leaded petrol

## 4.2 Touch Screen and Overlay

### 4.2.1 Autotex XE

Autotex XE covers the overlay surrounding the touch screen. Autotex XE has been developed to endure high or widely fluctuation temperatures, excessive humidity and strong levels of ultraviolet light.

#### Solvent Resistance

With continuous contact, some chemicals will begin to remove the UV absorber, reducing its UV resistance. Autotex XE withstands exposure of 5 hours duration under DIN 42 115 Part 2 to the following chemicals without significant visible change or loss of UV resistance:

Acetic acid (10%)	Glycerine	Pure Turpentine
Ajax / Vim in solution	Gumption <sup>1</sup>	SBP 60/95 <sup>1</sup>
Ammonia (2%) <sup>1</sup>	Hydrochloric acid (10%)	Sodium carbonate solution <sup>1</sup>
Ariel powder in solution <sup>1</sup>	Linseed oil	Sulfuric acid (10%)
Bleach <sup>1</sup>	Nitric acid (10%)	Tomato ketchup
Castor oil	Paraffin oil	Water
Caustic soda (2%) <sup>1</sup>	Persil powder in solution <sup>1</sup>	White Spirit
Cutting oil	Petroleum spirit <sup>1</sup>	Windex <sup>1</sup>
Diesel	Potassium carbonate solution <sup>1</sup>	Wisk
Downey / Lenor <sup>1</sup>	Potassium ferricyanide	

<sup>1</sup> Extremely faint glossing of the texture was noted.

Exposure to the following chemicals under the above conditions causes slight glossing of the texture and a reduction in the UV resistance of the product. Occasional splashing with the chemicals will not affect the texture or reduce UV resistance.

Cyclohexanol <sup>1</sup>	Glycol	Isopropanol
Formaldehyde solution	Industrial Methylated Spirits	Methanol
Formic acid (50%)		

<sup>1</sup> A white stain was noted.

Exposure to the following chemicals under the above conditions will cause blistering to the texture. However occasional splashing will not affect texture or reduce UV resistance.

Acetone	Methyl Ethyl Ketone	Toulene
---------	---------------------	---------

Autotex XE is not resistant to the following:

Benzyl alcohol	Concentrated mineral acids	Methylene chloride
Concentrated caustic solution	High pressure steam at over 100°	

### 4.2.2 Touch Screen Surface

The touch screen surface on the panel withstands exposure of more than 24 hours duration to the following chemicals without visible change:

Acetone	Methyl ethyl ketone	Sulfuric acid (40%)
Ammonia (5%)	n-Hexane	Toluene
Ethanol	Nitric acid (70%)	Xylene
Hydrochloric acid (6%)	Salt solution (5%)	

Everything for your HMI running



## 5 Operator Panel Drawings

### 5.1 Communication Ports

#### RS-232

Pin no	Signal	Signal Name	Signal direction
1	DCD	Data Carrier Detect	Input
2	RD	Receive Data	Input
3	TD	Transmit Data	Output
4	DTR	Data Terminal Ready	Output
5	SG	Signal Ground	-
6	DSR	Data Set Ready	Input
7	RTS	Request To Send	Output
8	CTS	Clear To Send	Input
9	RI	Ring Indicator	Input

#### RS-422/485

Pin no	RS-422		RS-485	
	Signal	Signal direction	Signal	Signal direction
2	TxD+	Output	Tx/Rx+	In/Output
15	TxD-	Output	Tx/Rx-	In/Output
3	RxD+	Input		
16	RxD-	Input		
4	RTS+	Output		
17	RTS-	Output		
5	CTS+	Input		
18	CTS-	Input		
20	1)			
21	1)			
6	Do not use		2) Bus termination	4) Connect to pin no.19 for bus-termination.
19	Do not use		3) Bus termination	See above
7,8	0V		0V	
14	+5V <100mA	Output	+5V <100mA	Output

- 1) Pin no 20 connected to pin no 21 internal in the terminal  
 2) Directly connected internally to pin no. 2 (Tx/Rx+).  
 3) Connected to pin no. 15 (Tx/Rx-) internally via a 120ohm 1/4W resistor.  
 4) NOTE! Only the first and the last unit on the bus should be terminated.

#### USB

Pin no	Signal	Signal direction
1	VBUS	-
2	D-	In/Output
3	D+	In/Output
4	GND	-

Frame connected to chassis.

#### Ethernet

Pin no	Signal	Signal direction
1	Tx+	Output
2	Tx-	Output
3	Rx+	Input
6	Rx-	Input
4,5,7,8	GND	

Drawing No. S-5005, Date 2004-10-27

Everything for your HMI running

## 5.2 EXTER T100 Outline

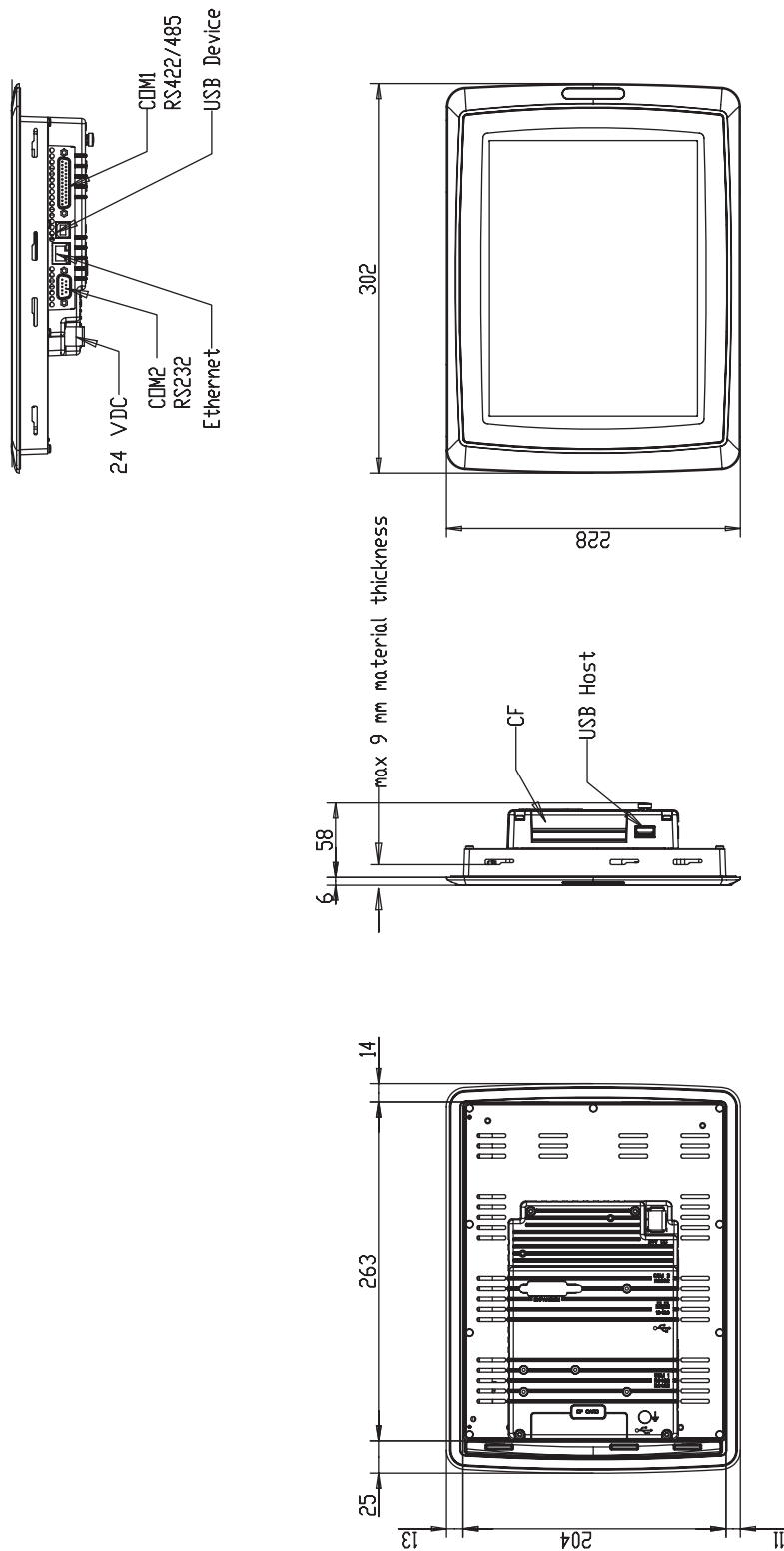

Drawing No. S-5113, Date 2004-10-26

## 6 Additional Installation Tips

When experiencing communication problems in for example noisy environments or when operating close to temperature limits, the following recommendations are to be noticed.

### 6.1 Grounding the Operator Panel

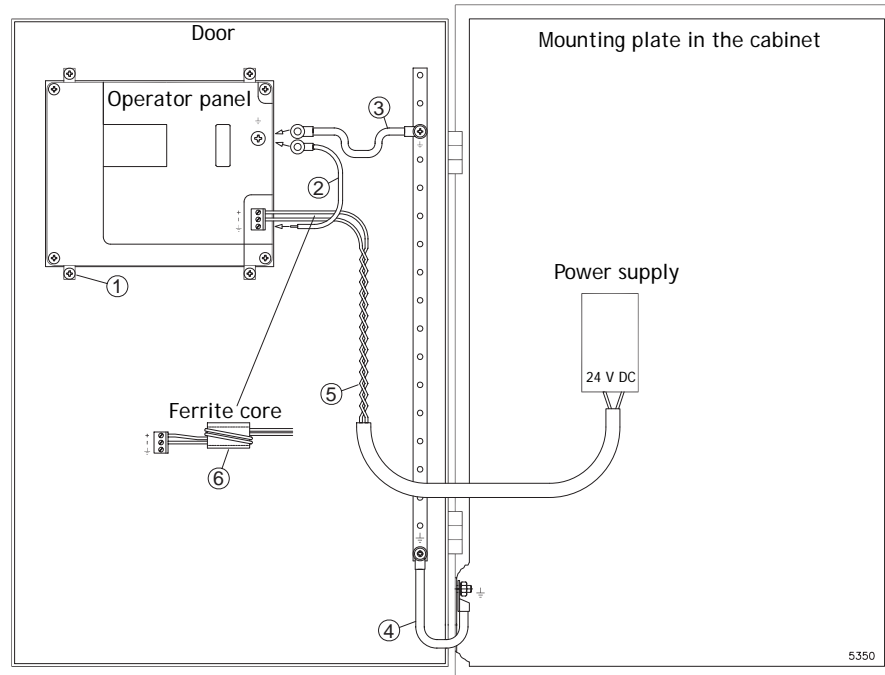

1. The operator panel's mounting clamps do not provide a secure grounding connection between the panel and the device cabinet.
2. Connect a 2.5 mm<sup>2</sup> wire between the operator panel's quick-connect plinth and the panel chassis.
3. Connect a 6 or 4 mm<sup>2</sup> wire or grounding braid between the panel's chassis and the closest grounding point on the door.
4. Connect a strong but short grounding braid between the door and the device cabinet.
5. Twist the cables onto the 24 V DC feed.
6. A ferrite core suppresses disturbances to the 24 V feed.
  - 2 turns around the ferrite core provide 4 times the suppression of 1 turn.
  - 3 turns around the ferrite core provide 9 times the suppression of 1 turn.

---

#### Remember:

The grounding wires should be short and the conductor should have a large area. A long, thin grounding wire has a very high impedance (resistance) at high frequencies and will not guide disturbances to the ground. Multi-wire conductors are better than single wire conductors with the same area. A braided conductor wire with the same area is even better. The best is a short, thick grounding braid.

---

## 6.2 Ethernet Connection in the Panel

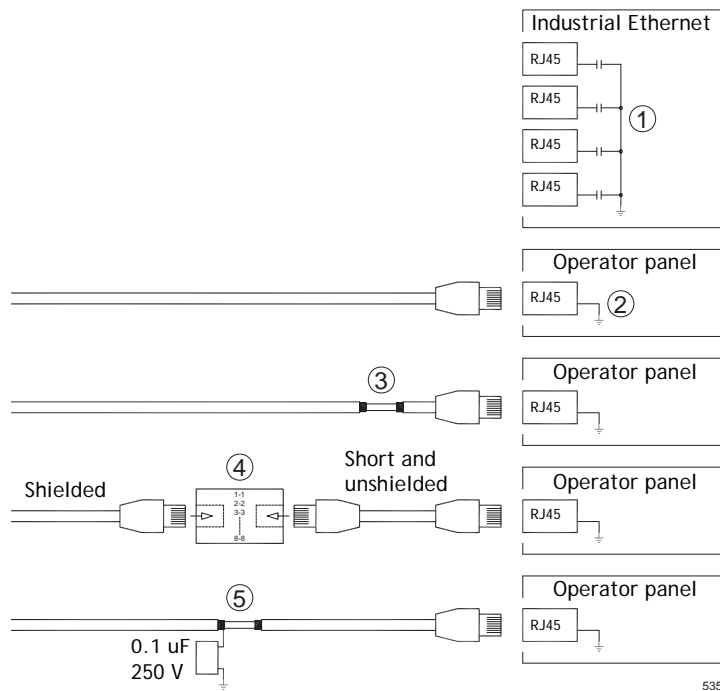

1. In some industrial units for Ethernet, the RJ45 contact's shield is connected to the chassis via a capacitor.
2. The operator panel's Ethernet shield is directly connected to the chassis.

Check whether the other Ethernet unit has its shield directly grounded or grounded via a capacitor.

In many cases, connecting the shielded Ethernet cabling to the chassis at both ends is inappropriate. Hum or grounding loops can occur. Unshielded cabling may even result in fewer communication errors.

A good solution may be to use a shielded Ethernet cable, but to connect the shield at one end only.

3. One option is to break the shield.
4. A more elegant method is to expand the shielded Ethernet cabling with a piece of unshielded Ethernet cable.
5. You can ground the shield via an external 0.1 uF/250 V plastic capacitor. This will connect the HF transients to the ground.

## 6.3 To Achieve Better EMC Protection

- Initially, use the original cabling from Beijer Electronics primarily.
- Use shielded cables for RS232 communication.
- Use twisted pair and shielded cabling for RS422 and RS485.
- Use the cabling intended for the bus type; Ethernet, Profibus, CC-Link, CAN, Device Net etc.
- Install and connect according to applicable specifications for the relevant bus standard.
- Use shielded cabling for Ethernet, preferably with foil + braided shield.
- D-sub covers should be shielded, and the shield should be connected to the cover 360 ° where the cable comes in.
- Connect the shield at both ends.

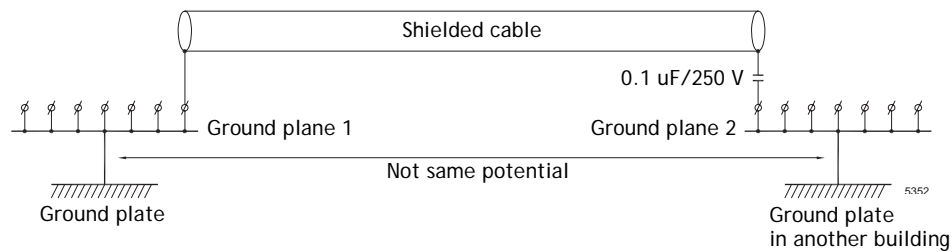

With longer distances, there is a risk that the ground potential may be different. In that case, the shield should only be connected at one end. A good alternative is to connect the other end of the shield to the ground via a 0.1 uF/250 V plastic capacitor. Both ends are then connected to the ground in terms of HF, but only connected to the ground at one end in terms of LF, thus avoiding the 50 Hz grounding loops.

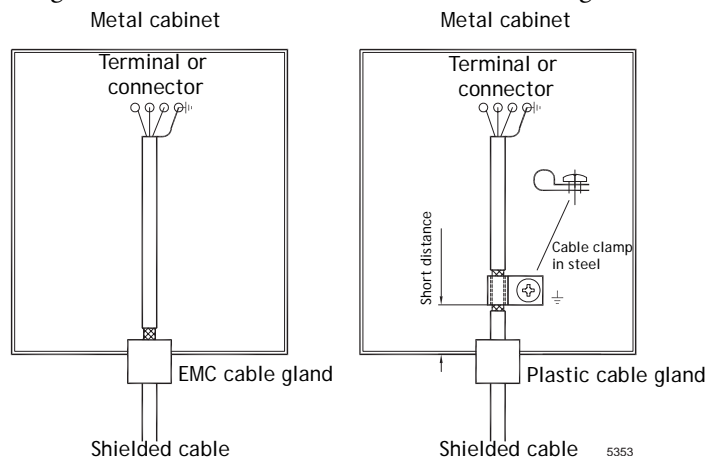

- Use an EMC cable gland or regular plastic cable gland, remove the outer jacket and connect the shield to the installation plate with a 360 ° metal cable clamp.
- Place the 24 V DC and communications cabling in one cable trunk/cable duct and 230/380 V AC in another. If the cables need to be crossed, cross them at 90 ° only. Avoid combining the cabling for stronger 24 V DC outputs with the communication cabling.
- Ferrite cores that are snapped onto the shielded cabling may remove minor disturbances. Large ferrite pieces that are snapped onto unshielded cabling and where the wires go 2-4 times around the cores are approximately 5-25 times more efficient.

## 6.4 Ambient Temperature

The maximum ambient temperature for the operator panel is provided in the specifications. The ambient temperature refers to the temperature in the device cabinet which cools the panel's electronics.

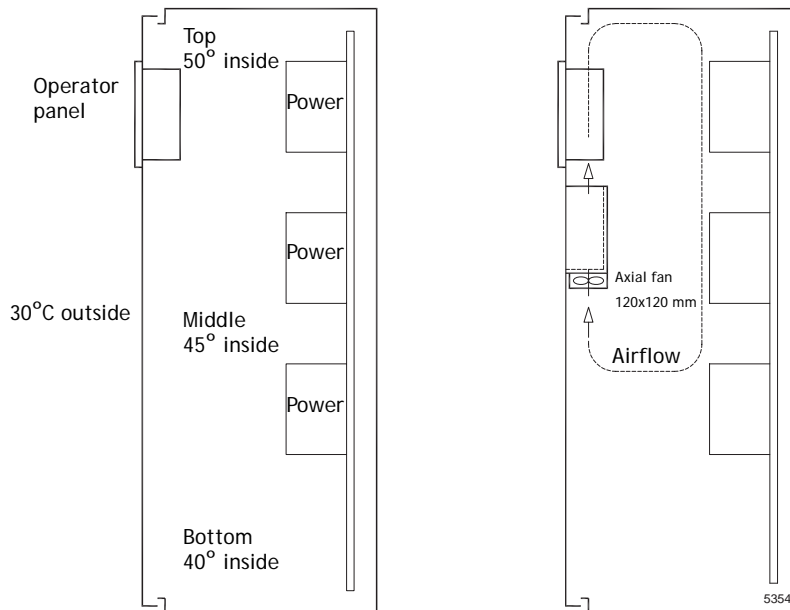

In most cases, the ambient temperature for the operator panel is significantly higher than the device cabinet's ambient temperature.

If the cabinet is tall and there are a number of heat-generating devices, the temperature at the top of the cabinet will be considerably higher than the theoretical temperature increase that would be expected. All electronics are sensitive to heat. The lifespan of an electrolytic capacitor is cut in half with an 8-10 ° increase in temperature. A 15-20 ° temperature increase results in a quarter of the lifespan etc.

Rittal has a good program for estimating the anticipated average temperature in the cabinet as well as a large program for controlling the temperature in the device cabinet.

An enamel-coated steel cabinet has a radiant heat value of 5.5 W/m<sup>2</sup> and degrees C.

Installing a fan inside the cabinet will even out the temperature, while moving air provides considerably better cooling than still air. A suitable fan is a 120 x 120 mm axial fan, available in 24 V DC, 115 and 230 V AC.

Install the fan so that it sits in the cooler area and will blow cold air against the operator panel. If the fan is mounted at the top and sucks air upwards, the fan's ambient temperature will be higher = shorter lifespan.

A good fan with a ball-bearing mounting has an expected lifespan of at least 40,000 hours (not a guaranteed lifespan) at 40 °C. This corresponds to at least 4 years of continuous use. If a thermostat is installed, the fan only needs to come on when needed.

Large graphic terminals draw only one fifth of the current when the background lighting is off. The loss effect drops from e.g. 25 W to only 5 W.

The operator panel's loss effect = supply voltage x current. Virtually no power goes to external users and no loss effects due to inputs.

## 6.5 Safety

Most of the operator panels are fed with 24 V DC.

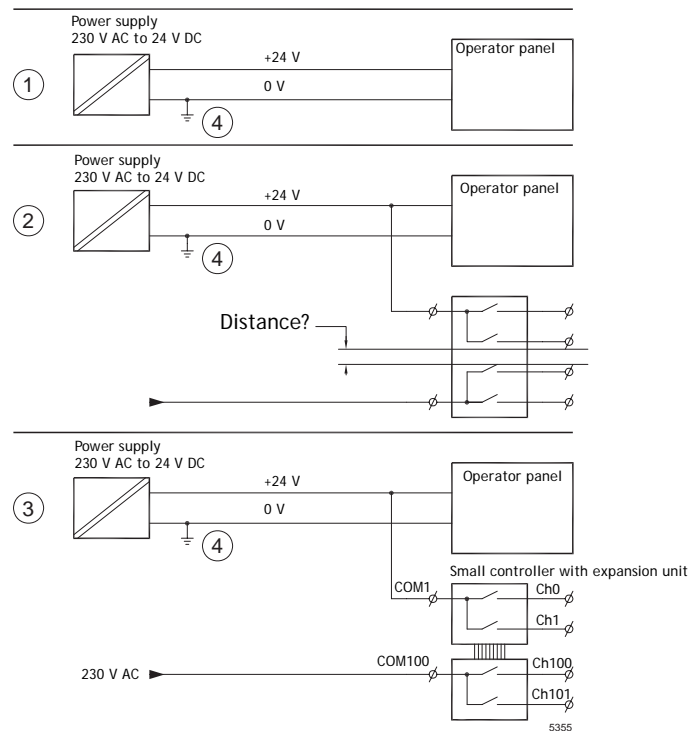

1. If you use a power supply that meets safety standards and only feeds the operator panel, there is no problem.
2. However, if you have a 24 V unit that also feeds other units, there is reason to be cautious.

The operator panel does not have insulation that meets safety requirements in the event of a potential short circuit between 230 V AC and 24 V DC. It is assumed that the 24 V feed is secure, for example, SELV according to EN 60950 (protection against electric shock) and UL 950.

### Example:

Here is an example that explains why a secure 24 V DC feed can be ruined by mixing 24 V relay contacts with 230 V AC relay contacts in a smaller controller. Check that the "clearances and creepage distances between 24 V DC and 230 V AC fulfill EN 60950 or UL 950". If not, input a separate 24 V unit into the operator panel.

3. If there is a substantial distance between the relay contacts for 24 V DC and 230 V AC, it is OK to use the same 24 V devices for all feeds.
4. Connect 0 V on the 24 V feed to the ground. This offers three advantages:
  - Safety is increased. The 24 V feed will not be live in the event of a faulty connection or short circuit between 0 V (24 V) and 230 V phase.
  - Transients on the 24 V feed are connected to the ground.
  - No risk that the 24 V feed is at a high level in relationship to the ground. This is not unusual since there is high static electricity.

## 6.6 Galvanic Isolation

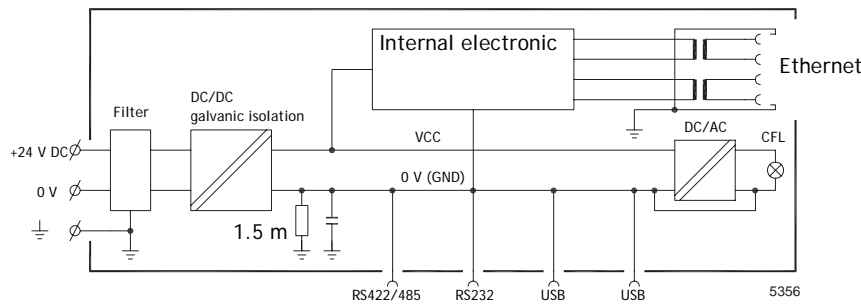

The operator panel has galvanic isolation against the 24 V DC feed but no galvanic isolation between the communication ports for RS232, RS422/485 and USB. Only the Ethernet connection has galvanic isolation.

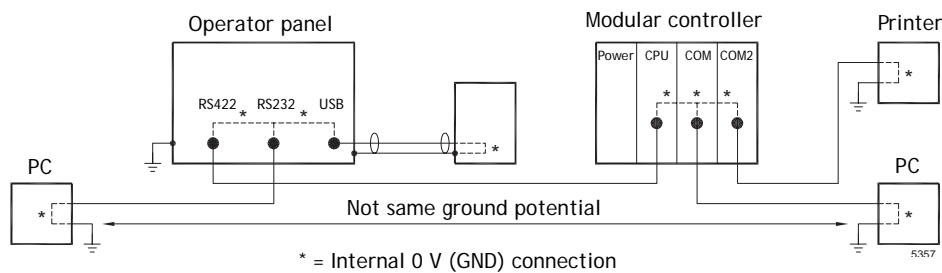

When a PC is connected to the panel, the panel's internal 0 V (GND) will be connected to the protective ground via the PC.

A number of USB devices can have the shield connected together with the protective ground. Here, the panel's 0 V (GND) is connected to the protective ground when, for example, a USB memory stick, keyboard or similar device is plugged in.

If a number of units are connected that have a 0 V and a ground connection, and these are connected to various grounding points, there is a substantial risk of problems. Grounding currents go through communication cables, the rear plate of the controller, and internally in the operator panel, and can cause errors.

Use external units to improve communication and achieve galvanic isolation. Westermo has good industry-standard insulators that are also insulated from the 24 V DC feed.

### Note:

It is very important to make sure that the 24 V feed in the external insulation unit is not connected to one of the communication outlets. If it does not have 100% insulation against the 24 V feed, disturbances and grounding currents from the 0 V on the 24 V side will disrupt communication.

Using this type of unit solves one problem but creates a larger problem!

A substandard installation may work now, but problems may arise when other devices are connected.



## 6.7 Cable and Bus Termination RS485

- Use shielded and twisted pair cable.  
The pair capacitance may not exceed 52.5 pF/m and area at least 0.25 mm<sup>2</sup> (AWG 24), if you want to use the maximum transfer distance and maximum transfer speed.
- 0 V, the reference voltage for communication should be included in the cabling. With two-way communication use two pairs; one pair for communication and one pair for 0 V.
- The shield must be grounded at one end. The other end is usually grounded, but with longer distances or when there is a difference in the ground potential, the shield should be connected to the ground via 0.1 uF/250 V plastic capacitor to prevent ground current in the braided shield.

A number of manufacturers recommend that the shield be grounded at each node. Various manufacturers have different systems for bus termination. The RS485 standard does not describe how the “Fail Safe” function would be carried out, just that the system should be able to handle the error.

Depending on the recipients’ design, the bus wires may be on the same level or require pull-up or pull-down to ensure that no faulty signals are detected when the bus is in resting mode (all transmitters are disconnected).

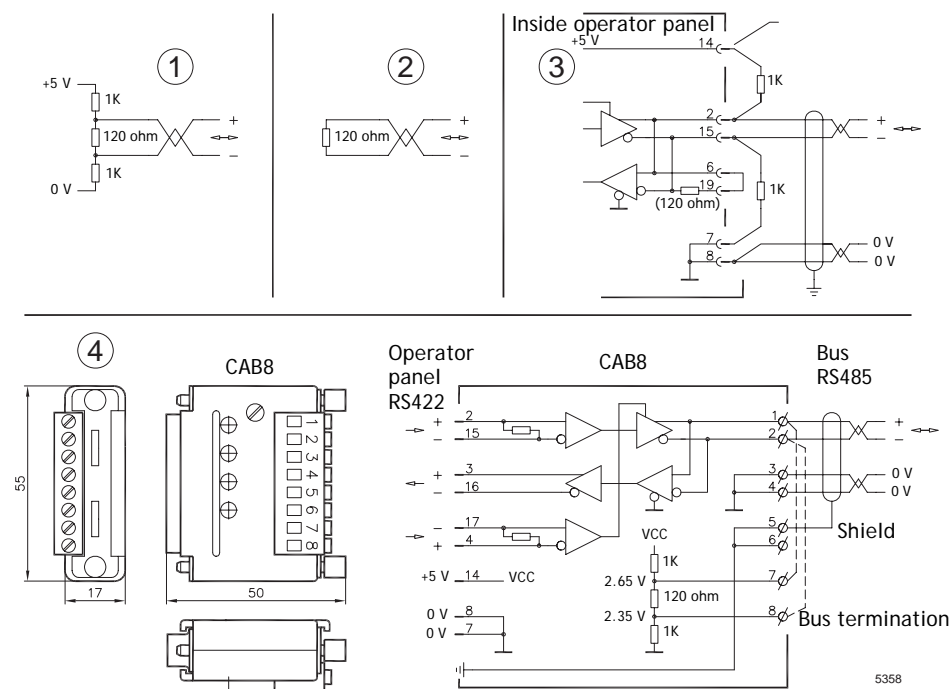

1. Some (older) operator panels had pull-up and pull-down resistance except for the actual bus termination at 120 ohm, similar to Westermo and Profibus.
2. Newer panels have another type of recipient, so-called built-in “Fail Safe”, where simple bus termination resistance is sufficient.

If other nodes on the RS485 network require pull-up and pull-down and the operator panel is at one end of the loop, one of the following procedures can be carried out:

3. Connect two 1k/0.25 W resistors in the 25-pole D-sub contact. Set jumper pins 6-19.
4. Use CAB8. It offers the option of bus termination with pull-up/-down. It is also easy to connect the bus cable via the screw terminal block.

Everything for your HMI running

# Beijer

ELECTRONICS

---

## HEAD OFFICE

### SWEDEN

Beijer Electronics Products AB  
Box 426  
SE-201 24 Malmö, Sweden  
Tel: +46 40 35 86 00  
Fax: +46 40 93 23 01  
info@beijerelectronics.com

## SUBSIDIARIES

### GERMANY

Elektronik-Systeme Lauer GmbH & Co. KG  
Kelterstraße 59  
72669 Unterensingen, GERMANY  
Tel: +49 7022 9660 0  
Fax: +49 7022 9660 103  
info@lauer-hmi.com

### TAIWAN

Hitech Electronics Corp.  
7 & 8 F, No. 108 Min-Quan Road  
Shin-Tien, Taipei Shien, TAIWAN, R.O.C. 231  
Tel: +886-2-2218-3600  
Fax: +886-2-2218-9547  
info.hmi@hitech-lcd.com.tw

### USA

Beijer Electronics Inc.  
939 N. Plum Grove Road, Suite F  
Schaumburg, IL 601 73, USA  
Tel: +1 847 619 6068  
Fax: +1 847 619 6674  
info.usa@beijerelectronics.com

### CHINA

Beijer Electronics Co. Ltd  
Room 201, Building B, No. 1618,  
Yishan Road, Shanghai 201103, CHINA  
Tel: +86 21 6145 0400  
Fax: +86 21 6145 0499  
info@beijerelectronics.cn

Everything for your HMI running



Touch.Keypad.Display  
✉ sales@vicpas.com  
☎ +86-15876525394