

The dedicated industrial touch screen is a solid choice for industrial operator stations due to its reliability, maintainability, and ease-of-programming. However, the need for network connectivity, programming flexibility, and local data storage drove the demand for panel-PCs. PCs meet the needs of the application at the expense of reliability and maintainability, while introducing significant programming complexity.



Omron's NS-Series Advanced HMI incorporates the features sought by users of panel-PCs into the proven, easy-to-use platform of the dedicated industrial touch screen. It is truly a hybrid platform, providing the best of both worlds.

- 100% new hardware and software architectures designed and manufactured by Omron.
- 256-color displays in 7" STN, 10" TFT, and 12" TFT clearly display information to the operator.
- Network connections include optional built-in ethernet and an optional Controller Link module, allowing access to PLC data three network layers away.
- The NS can participate in a data link exchange with other Controller Link nodes on the Controller Link network.
- The NS-Series can simultaneously access serial port A, serial port B, ethernet, and Controller Link ports, allowing one NS unit to service multiple PLCs.
- Compact Flash memory cards can be used to transfer and store screen project, OS, and firmware data. The cards can also store recipe data, alarm history, screen history, and logged data in TXT, RTF, or CSV format. All files stored on the card can be accessed using serial, ethernet, or Controller Link networks.
- Macro functions, triggered by screen, object, or PLC events, add a new dimension of control possibilities.
- Optional 4-channel video input board allows the NS-Series to be the touch screen and video monitor (10" and 12" models only). This is perfect for monitoring vision systems, security cameras, or remote parts of a machine. Video image displays 65,535 colors in 800 x 600, 640 x 480, or 320 x 240 resolution. User can select to make a *.BMP record of a displayed image that is then stored on the local compact flash card.
- Pop-up windows, reusable menu windows, tabbed "dialog box" style windows, and object visibility control allow for very efficient use of screen real estate, and reduce programming effort.
- Memory is expandable from 4 MB to 20 MB (for 10" and 12" models - 7" model is fixed at 6 MB)
- NS-Designer, the Windows®-based development software, is designed to dramatically reduce screen development time and offers features to simplify debugging.
- Multiple languages can be programmed into each project. The desired language text can be selected at the touch of a button.
- Ultra-thin profile of 1.65" minimizes intrusion of the NS unit into the panel, freeing up space for other control components.
- NEMA 4 Compliant, UL
- Conforms to cULus **Class I Division 2**, for installation into hazardous locations.





Functional Objects List

Fixed Objects

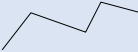









Name	Shape
Rectangle	
Circle/Oval	

Name	Shape
Straight line	
Polyline	

Name	Shape
Polygon	
Sector	

Name	Shape
Arc	

Functional Objects

Name/Icon	Contents	Description	Name/Icon	Contents	Description
ON/OFF button 	Changes the ON/OFF status of the specified bit address. Four kinds of button operation are possible	The write address and display addresses 1 and 2 can be specified separately; Four colors can be displayed with the four different combinations of the bits in display addresses 1 and 2; The display color can be specified indirectly; Labels can be switched according to the contents of the write address or another address; A write confirmation dialog box can be displayed; A password can be set; The button shape can be selected from a list	Thumbwheel switch 	Displays the word data in the specified address as numeral value; The value can be increased or decreased by pressing the + and - buttons	The + and - buttons can be positioned at the top or bottom; A write confirmation dialog box can be displayed; A password can be set
Word button 	Writes numeral data to the specified word address	An increment/decrement value can be set so that the specified word will be incremented/decremented by that amount each time the button is pressed; A list of numeral values (two or more values) can be displayed in a pop-up menu so that the specified word will be set to the selected numeral value; The display color can be specified indirectly; A write confirmation dialog box can be displayed; A password can be set	Analog meter 	Displays the specified word address data in a 3-color analog meter; The meter can be a full circle, semi-circle, or quarter-circle	The colors of the borders and ranges can be set; The range colors and background color can be specified indirectly
Command button 	Used to execute special functions such as switching screens, controlling pop-up screens, and transmitting a character string to the highlighted input field (key button function)	When switching screens, the screen number can be specified indirectly; When using the key button function, the data in and after a specified address can be treated as character string code, converted to a character string, and transmitted; The display color can be specified indirectly; A write confirmation dialog box can be displayed	Level meter 	Displays the specified word address data in a 3-color level meter	The colors of the borders and ranges can be set; The range colors and background color can be specified indirectly; Scale lines can be displayed
Bit lamp 	The ON/OFF status of the lamp changes according to the ON/OFF status of the specified bit address	The display color can be specified indirectly; The lamp shape can be selected from a list	Broken-line graph 	Displays the word data in the specified word addresses as a broken line graph	Maximum/minimum limits can be set and different colors can be displayed for lines within the range and outside of the range; Marker displays can be specified; Scale lines can be displayed
Word lamp 	The lamp color or pattern changes according to the status (0 to 9) of the specified word address	The 10 display colors/patterns can be specified indirectly; The lamp shape can be selected from a list	Bitmap 	Displays a bitmap (BMP or JPEG)	The bitmap file can be specified indirectly through a text file
Text 	Displays a registered character string. It is possible to reference a text file and display a specific line in that file	Windows font faces and sizes can be used	Alarm/event display 	Displays the current alarms and events in order of their importance	Multiple messages can be displayed with flowing text
Numeral display & input 	Displays the numeric value stored at the specified word address and allows data to be input to the address from a ten keypad	The ten keypad is a standard system element; Data can also be input from a user-defined command button; Values can be converted and displayed at a specified scale or displayed with units; Maximum and minimum input limits can be set; Maximum and minimum limits can be monitored; A write confirmation dialog box can be displayed; A password can be set	Alarm/event summary & history 	Displays a summary or history of the alarms and events that have occurred	It is possible to display the time that the alarm occurred and the time that it was cleared
String display & input 	Displays the character string data stored at specified addresses and allows data to be input from the keyboard	The virtual keyboard is a standard system element. Data can also be input from a user-defined command button; Japanese Kanji inputs can be displayed; Korean, Chinese, and Taiwanese can also be displayed with Unicode; A write confirmation dialog box can be displayed; A password can be set	Date 	Displays and sets the date	Displays the day of the week
List selection 	Displays registered character strings as a list for selection	Character string data can be stored in specified consecutive addresses or text files; A password can be set	Time 	Displays and sets the time	
Data block tables 	Displays a data block table object	Preset recipe data such as manufacturing information can be written to the PLC or read from the PLC	Data log graph 	Displays the word data in the specified word addresses as a trend graph	Logging data can be saved in the Memory Card in CSV format; Maximum/minimum limits can be set and different colors can be displayed for lines within the range and outside of the range; Marker displays can be specified; Scale lines can be displayed
			Video display 	Displays a video display object	Video inputs can be received from up to 4 video cameras at the same time; The 65,535-color display provides excellent visibility; Can be selected from three display sizes

Slim, Durable, and Prepared for the Long Haul

- With a miniscule 1.65" mounting depth, these thin-profiled touchscreens can be incorporated easily into new and existing panels or machines.
- A built-in Expansion Interface for today's Video and Controller Link modules, and future expandability.
- The NS-Series touchscreens have backlights with the longest life expectancy in the industry. At room temperature, the average life expectancy is 50,000 hours minimum for the NS12 and NS10, and 40,000 hours minimum for the NS7.

NS12, NS10

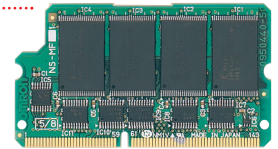
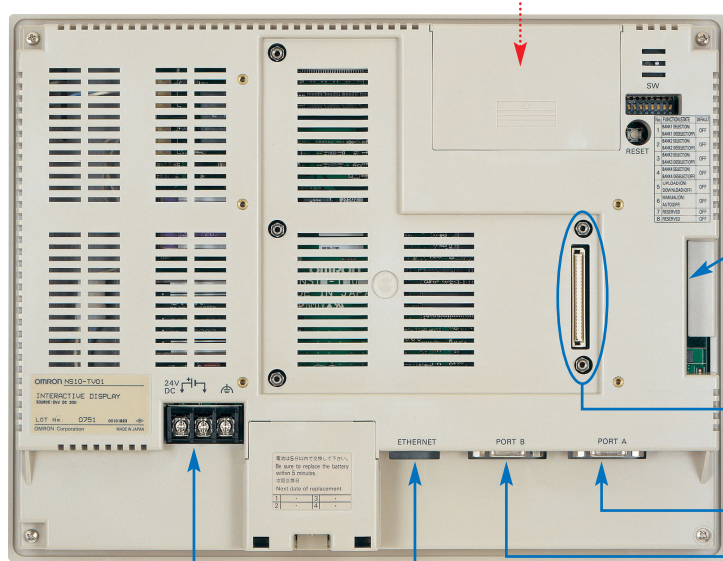

Expansion Memory Board
 In the NS12 and NS10 touchscreens, memory capacity can be increased to 20 Mbytes max. by adding optional 8 MB or 16 MB Expansion Memory Cards.

Memory Card interface



Memory Card

Expansion interface

RS-232C serial port A

RS-232C serial port B

A bar code reader can be connected to the serial port.
 Recommended bar code reader: V520-RH21-6

Ethernet (10 Base-T)

Power Supply (24 VDC)

Battery

NS7

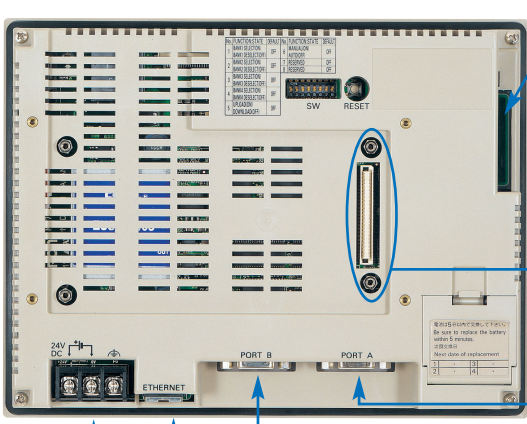

Memory Card interface



Memory Card

Expansion interface

Battery

RS-232C serial port A

RS-232C serial port B

Ethernet (10 Base-T)

Power Supply (24 VDC)

A bar code reader can be connected to the serial port.
 Recommended bar code reader: V520-RH21-6

Accessories

<p>Video Input Unit</p>	<p>Expansion Memory Board (Compatible with NS 10/12 only)</p>	<p>Memory Card Adapter</p>	<p>Communication Cable</p>
<p>Controller Link Interface Unit</p>	<p>Memory Card</p>	<p>RS-232/RS-422A Adapter</p>	<p>Protective Cover/Anti-reflection Sheet for NS-Series</p>

Dimensions

■ NS12/10 Operator Interface Terminal Units: mm (inches)

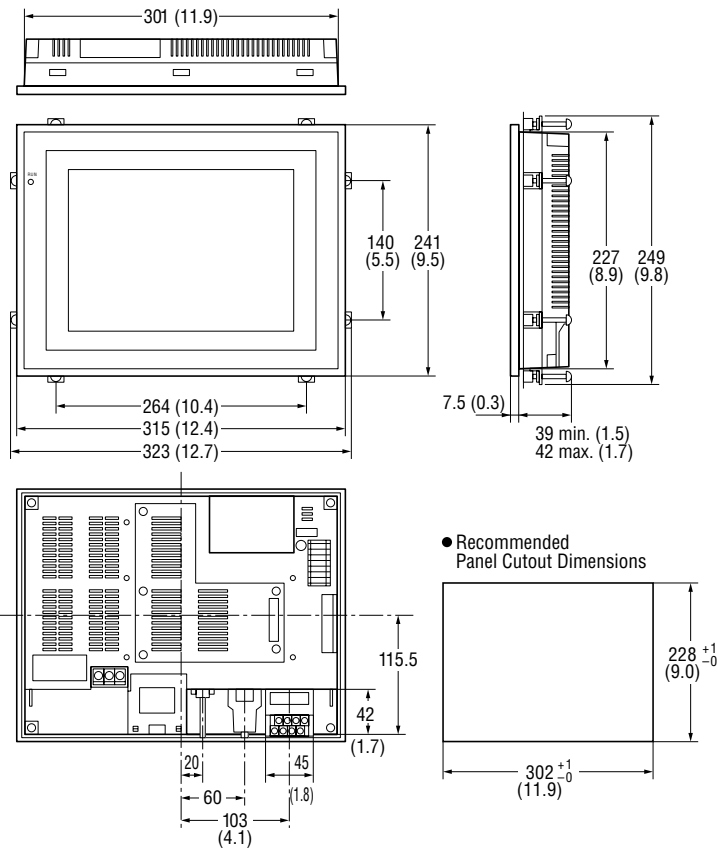

■ NS-CA001 Video Input Unit Units: mm (inches)

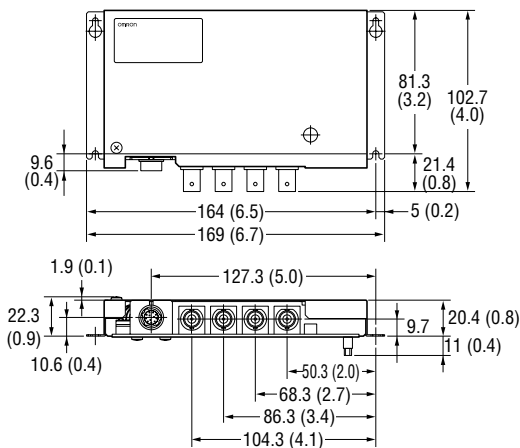

Superior environmental resistance meets IP65F standards.

Flush surface construction is used for superior environmental resistance and the enclosure rating for the front of the NS units are IP65F compliant.

IP — International Protection

6 — Dust and dirt will not enter interior.
(Enclosure protects against foreign objects.)

5 — There are no adverse effects from a water stream from any direction.
(Enclosure protects against water intrusion.)

F — There are no harmful effects from oil droplets or spray from any direction.
(Enclosure protects against oil intrusion.)

Note: May not be applicable in environments with long-term exposure to water or oil.

■ NS7 Operator Interface Terminal Units: mm (inches)

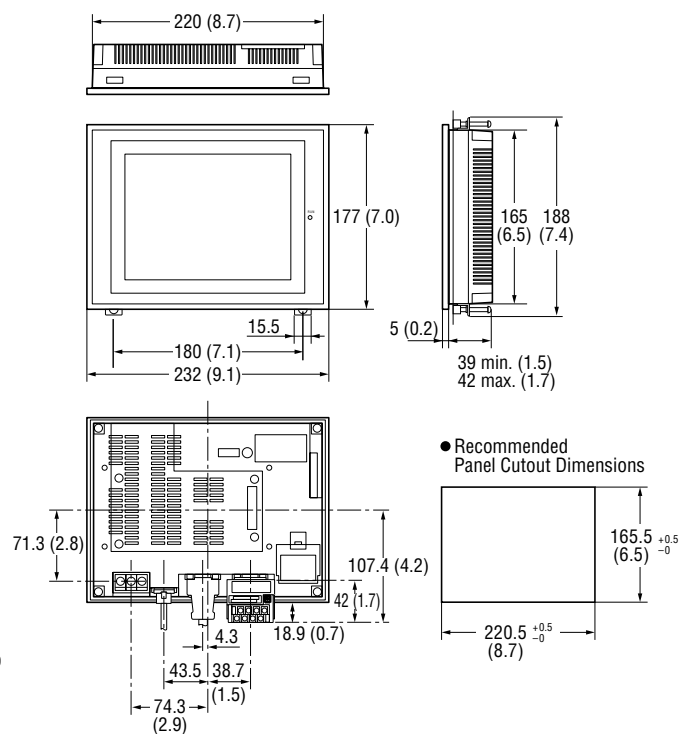

■ NS-CLK21 Controller Link Interface Unit Units: mm (inches)

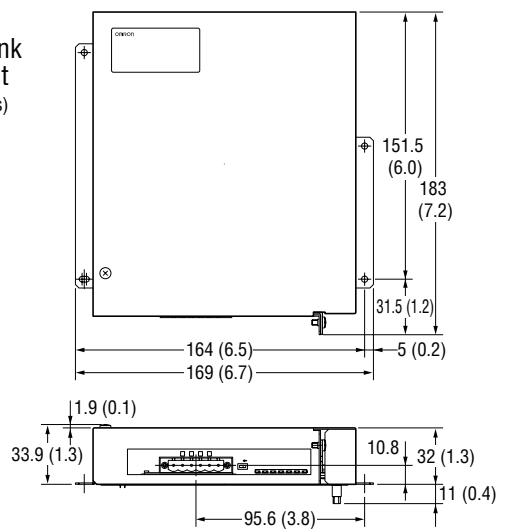

Meets International Standards and Exports are Not Restricted

The NS units conform to UL standards (cULus), CSA standards, and EC Directives.

In addition, there are no export restrictions on the NS units.



*The Controller Link Interface Unit has not been approved for conformity to EC Directives at this time (approval pending).

Performance/Specifications

General Specifications

Item	Specifications
Rated power supply voltage	24 VDC
Allowable voltage range	20.4 to 27.6 VDC (24 VDC ±15%)
Power consumption	20 W max.
Ambient operating temperature	0 to 50°C (See notes 1 and 2)
Storage temperature	-20 to 60°C (See note 2)
Ambient operating humidity	35% to 85% (0 to 40°C) with no condensation 35% to 60% (40 to 50°C) with no condensation
Operating environment	No corrosive gases
Noise immunity	Conforms to IEC61000-4-4, 2 kV (power lines)
Vibration resistance (during operation)	Conforms to JIS C0040; 10 to 57 Hz, 0.075 mm amplitude, 57 to 150 Hz; 9.8 m/s ² 30 min each in X, Y, and Z directions
Shock resistance (during operation)	Conforms to JIS C0041; 147 m/s ² 3 times each in direction of X, Y, and Z
Weight	2.5 kg max.
Enclosure rating	Front operating panel: IP65F and NEMA4 compliant (See note 3)
Battery life	5 years (at 25°C); Replace battery within 5 days after the battery runs low (indicator lights orange)
Applicable standards	Conforms to cULus Class1 Division2 and EC Directives

Note 1: The operating temperature is subject to the following restrictions according to the mounting angle. Mounting angle of 0 to 30°C to the horizontal: Operating temperature range of 0 to 45°C Mounting angle of 30 to 90°C to the horizontal: Operating temperature range of 0 to 50°C

Note 2: Operate the PT within the temperature and humidity ranges shown in the following diagram.

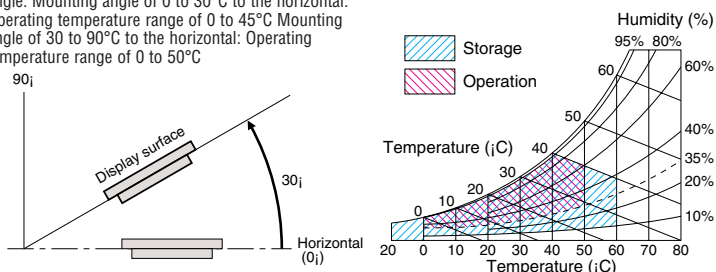

Note 3: May not be applicable in locations with long-term exposure to oil.

Characteristics

Display Specifications

Item	NS12	NS10	NS7
Display panel			
Display device	High-definition TFT color LCD	High-definition TFT color LCD	High-definition STN color LCD
Number of dots	800 dot H x 600 dot V	640 dot H x 480 dot V	640 dot H x 480 dot V
Display color	256 colors	256 colors	256 colors
Effective display area mm (in)	246.0 W x 184.5 H (12.1)	215.2 W x 162.4 H (10.4)	160.42 W x 121.1 H (7.7)
Field of vision	Left/right ±60°, Top 45°, bottom 55°	Left/right ±60°, Top 35°, bottom 65°	Left/right ±50°, Top 40°, bottom 30°
Backlight (See note 4)			
Service life	50,000 hours min. (See note 1)	50,000 hours min. (See note 1)	40,000 hours min. (See note 1)
Brightness adjustment	There are 3 levels that can be set with the touch panel. (See note 2)		
Backlight error detection	Error is detected automatically, and the RUN indicator flashes green as notification. (See note 3)		

Note 1: This is the estimated time before brightness is reduced by half at room temperature and humidity. It is not a guaranteed value. The service life will be drastically shortened if PT is used at low temperatures. For example, using the PT at temperatures of 0°C will reduce the service life to approximately 10,000 hours (reference value).

Note 2: The brightness cannot be adjusted much.

Note 3: This function does not indicate that the service life has been reached. It detects when the backlight is not lit due to a disconnection or other errors. Backlight error detection indicates that all backlights (2) are OFF.

Note 4: Contact your nearest OMRON representative to replace the backlight.

Touch Panel (Matrix type) Operating Specifications

Item	Specification
Method	Resistive membrane
Number of switches	
NS12	1,900 (50 horizontal x 38 vertical) 16 x 16 dots for each switch
NS10	1,200 (40 horizontal x 30 vertical) 16 x 16 dots for each switch
NS7	768 (32 horizontal x 24 vertical) 20 x 20 dots for each switch
Input	Pressure-sensitive
Service life	1,000,000 touch operations

Operating Specifications

Item	NS12	NS10	NS7
Standard screen data capacity	4MB	4MB	6MB
Screen data capacity when Expansion Memory is used	20MB (4MB+16MB)	20MB (4MB+16MB)	—

External Interface Specifications

Item	NS10/12	NS7
Expansion memory interface (See note)	One slot for expanding screen data capacity; 8-Mbyte or 16-Mbyte expansion	None
Memory card interface	One ATA-Compact Flash interface slot; Used to transfer and store screen data and to store history data	
Expansion interface	For Expansion Interface Units; Used to install various Interface Units	

Note: This interface is for NS-series Units only. Units not specified in this manual cannot be installed.

Communications Specifications

Serial Communications

Item	Specification
Port A	Conforms to EIA RS-232C; D-Sub female 9-pin connector; 5-V output (250 mA max.) through pin 6 (See note)
Port B	Conforms to EIA RS-232C; D-Sub female 9-pin connector; 5-V output (250 mA max.) through pin 6 (See note)

Note: The 5-V outputs of serial ports A and B cannot be used at the same time.

Controller Link (Wired-type) Specifications

Item	Specification
Baud rate	2M/1M/500K
Transmission path	Shielded twisted-pair cable (special cable)

Ethernet Specifications (NS12-TS01(B), NS10-TS01(B), and NS7-TS01(B) Only)

Item	Specification
Conformance standards	Conforms to IEEE 802.3/Ethernet (10Base-T)

Video Input Specifications

Item	Specification
Resolution	320 x 240, 640 x 480, or 800 x 600 dots
Input signal	NTSC composite video or PAL
Cameras	Number of cameras: 4 max.

Display Element Specifications

Item	Specification				
Display text	Raster font	Displayable characters	Base size		
	Font name	Rough	Alphanumeric characters or Japanese katakana, kanji	8 x 8	1 x 1, 1 x 2, 2 x 1, 2 x 2, 3 x 3, 4 x 4, 8 x 8
		Standard	Alphanumeric characters or Japanese katakana, kanji	8 x 16, 16 x 16	
		Fine	Alphanumeric characters or Japanese katakana, kanji	16 x 32, 32 x 32	
Text attributes	Vector font (text objects only)	Can be specified in NS-Designer; Font, style, and size can be specified			
	Color	256 colors			
	Font style (only when vector font is specified)	Bold or italic			
	Vertical alignment	Top, center, or bottom			
Flicker	Horizontal alignment	Left-justified, centered, or right-justified			
	Objects that can flicker	Functional objects	Up to 10 types can be registered; The flicker speed and flicker range can be set		
	Fixed objects	Select from 3 types; The flicker speed and flicker range are fixed			
Numeral units and scale settings	1,000 max.				
Alarm/event settings	500 max.				
Display colors	256 colors max.				

NS-Designer Operating Environment

Recommended CPU	Intel Celeron 400 MHz min.
Recommended memory	32 Mbytes min.
Hard disk free space	200 Mbytes are required at setup
CD-ROM drive	Required for installation
Display	A minimum resolution of 1024 x 768 pixels is recommended
Compatible OS	Microsoft® Windows 95®, Windows 98®, Windows NT 4.0® (service pack 3 or higher), Windows Me®, or Windows 2000®

NEC PC98-series computers are not supported except for the NEC PC98NX Series computers, which can be used like a PC at compatible computer.

Compatible Omron PLCs

■CPU Units (1:1 NT Link Connection)

Model number	Specifications	PLC model name
CQM1-CPU41-V1/CPU42-V1/CPU43-V1/CPU44-V1	With RS-232C connector (9-pin type)	C-Series CQM1
CQM1H-CPU21/CPU51/CPU61		C-Series CQM1H
CPM1-10/20CDR-□+CPM1-CIF01	Connect to peripheral port	C-Series CPM1
CPM1A-10/20/30/40CD□-□+CPM1-CIF01		C-Series CPM1A
CPM2A-30/40/60CD□□-□+CPM1-CIF01	Connect to RS-232C or peripheral port	C-Series CPM2A
CPM2C-10/20□□□□□□-□(See note 1)		C-Series CPM2C
C200HS-CPU21/CPU23/CPU31/CPU33	With RS-232C connector (9-pin type)	C-Series C200HS
C200HE-CPU32(-Z) (See note 2) /CPU42(-Z)		C-Series C200HE (-Z)
C200HG-CPU33(-Z) (See note 2) /CPU43(-Z) / CPU53(-Z) (See note 2) /CPU63(-Z)		C-Series C200HG (-Z)
C200HX-CPU34(-Z) (See note 2) /CPU44(-Z) / CPU54(-Z) (See note 2) /CPU64(-Z) /CPU65-Z/CPU85-Z		C-Series C200HX (-Z)
CV500/1000/2000-CPU01-V1 CVM1-CPU01-V2/CPU11-V2/CPU21-V2	With RS-232C connector (switching/9-pin type)	CVM1/CV-Series CVM1 or CV500/ CV1000/CV2000

Note 1: Use an Adapter Cable (CPM2C-CN111 or CS1W-CN114/118), CPM1-CIF01 RS-232C Adapter, or CPM1-CIF11 RS-422A Adapter to connect.

Note 2: A C200HW-COM02(-V1), C200HW-COM04(-V1), C200HW-COM05(-V1), or C200HW-COM06(-V1) Communications Board is required.

■CPU Units (1:N NT Link Connection)

Model number	Specifications	PLC model name
CS1G-CPU42H/CPU43H/CPU44H/CPU45H	With RS-232C connector (9-pin type)	CS-Series CS1G
CS1H-CPU63H/CPU64H/CPU65H/CPU66H/CPU67H		CS-Series CS1H
CJ1G-CPU42H/CPU43H/CPU44H/CPU45H (See note 1)		CJ-Series CJ1G
CJ1H-CPU65H/CPU66H (See note 1)		CJ-Series CJ1H
CQM1H-CPU61/51 with a CQM1H-SCB41 Serial Communications Board		C-Series CQM1H
C200HE-CPU32(-Z) (See note 2) /CPU42(-Z)		C-Series C200HE(-Z)
C200HG-CPU33(-Z) (See note 2) /CPU43(-Z) /CPU53(-Z) (See note 2) /CPU63(-Z)		C-Series C200HG(-Z)
C200HX-CPU34(-Z) (See note 2) /CPU44(-Z) /CPU54(-Z) (See note 2) / CPU64(-Z) /CPU65-Z/CPU85-Z		C-Series C200HX(-Z)

Note 1: The CJ1W-SCU41 Serial Communications Unit can also be connected.

Note 2: A C200HW-COM02/COM04/COM05/COM06(-V1) Communications Board is required.

Standard Models

Description		Part number	Description		Part number
NS12 Display	12" TFT, 800 x 600 dots, Ivory	NS12-TS00	Accessories	Video Input Unit, 4 channels, NTSC/PAL Signal Type	NS-CA001
	12" TFT, 800 x 600 dots, Black	NS12-TS00B		2 m Special Cable for the Console	F150-VKP (2 m)
	12" TFT, 800 x 600 dots, Ivory, Ethernet	NS12-TS01		5 m Special Cable for the Console	F150-VKP (5 m)
	12" TFT, 800 x 600 dots, Black, Ethernet	NS12-TS01B		Controller Link Interface Unit	NS-CLK21
NS10 Display	10" TFT, 640 x 480 dots, Ivory	NS10-TV00		8 MB Expansion Memory Board	NS-MF081
	10" TFT, 640 x 480 dots, Black	NS10-TV00B		16 MB Expansion Memory Board	NS-MF161
	10" TFT, 640 x 480 dots, Ivory, Ethernet	NS10-TV01		RS-232C/RS-422A Adapter	NS-AL002
	10" TFT, 640 x 480 dots, Black, Ethernet	NS10-TV01B		NS12/10 Anti-reflection Sheets (5 qty.)	NS12-KBA04
NS7 Display	7" STN, 640 x 480 dots, Ivory	NS7-SV00		NS7 Anti-reflection Sheets (5 qty.)	NS7-KBA04
	7" STN, 640 x 480 dots, Black	NS7-SV00B		NS12/10 Protective Covers (5 pack)	NS12-KBA05
	7" STN, 640 x 480 dots, Ivory, Ethernet	NS7-SV01		NS7 Protective Covers (5 pack)	NS7-KBA05
	7" STN, 640 x 480 dots, Black, Ethernet	NS7-SV01B		8 MB Memory Card	HMC-EF861
NS-Designer Software	Windows English Version on CD-ROM	NS-NSDC1-EV2		15 MB Memory Card	HMC-EF171
NS Communication Cables	Programming Cable 9-9 pin	C200H-CN229-EU		30 MB Memory Card	HMC-EF371
	50 cm 9-9 pin Cable, NS to Omron PLC	C200H-CN510-EU	48 MB Memory Card	HMC-EF571	
	3 m 9-9 pin Cable, NS to Omron PLC	C200H-CN320-EU	Memory Card Adapter for PCMCIA	HMC-AP001	
	5 m 9-9 pin Cable, NS to Omron PLC	C200H-CN520-EU	NS12/10 Battery	3G2A9-BAT08	
	NS connection: 2 m 9 pins - CS1, CJ1, CQM1H, CPM2C, Peripheral port	XW2Z-200T-2	NS7 Battery	CPM2A-BAT01	
	PLC connection: 5 m 9 pins - CS1, CJ1, CQM1H, CPM2C, Peripheral port	XW2Z-500T-2	Bar Code Reader (Refer to the Catalog for details)	V520-RH21-6	



OMRON ELECTRONICS LLC

One East Commerce Drive
Schaumburg, IL 60173

1-800-55-OMRON

DSP25FAD1

07/02

OMRON ON-LINE

Global - <http://www.omron.com>
USA - <http://www.omron.com/oei>
Canada - <http://www.omron.com/oci>

Specifications subject to change without notice

OMRON CANADA, INC.

885 Milner Avenue
Toronto, Ontario M1B 5V8

416-286-6465

Printed in USA