

iPendant™

Basic Description

The ergonomically-designed *iPendant* is the next generation in user interface technology from FANUC Robotics America. The Internet-ready *iPendant* allows users to browse the information available on the Internet/Intranet. Users can also customize robot information displayed on the *iPendant*.

The intuitive multi-window color graphic interface on the *iPendant* makes FANUC robots easier to use than ever before. It provides integrated help and diagnostics functions as well as enhanced robot and process data allowing instant access to critical information right on the teach pendant.

Key Features

- Ergonomically-designed color pendant
- Intuitive multi-window display and fly-out menus
- Multiple program editing
- Integrated help and diagnostics
- PMC ladder logic monitoring and editing (optional)
- User-customizable interface
- Internet-enabled embedded web browser (optional)
- Touch screen support (optional)

Features/Benefits

- *iPendant* button layout, menus and screens are similar in look and feel, making it interchangeable with previous generation teach pendants.



- The *iPendant* uses color highlighting, fly-out menus and a split-screen display to make important information easier to find. This virtually eliminates any additional training time required for users familiar with other FANUC Robotics products.
- A simple-to-use navigation system provides all the choices on a single screen for fast menu navigation.
- Integrated help and diagnostics provide instant help to recover from production interruptions.
- Online help menus are available for every *iPendant* function. These are an optimized version of the information that is available in the standard robot documentation set.
- Online cause and remedy information is available for each robot alarm. Users can simply press the DIAG key when an alarm is active and the cause and remedy information for the alarm is displayed, providing instant information on what caused the alarm and how to correct it.
- With touch screen support for *iPendant* (optional), the user will be able to select items on any of the system menus and custom screens simply by touching the screen.
- The optional *iPendant* version of the DRC (Diagnostic Resource Center) provides advanced troubleshooting information as well as subsystem schematics, connector pinouts and machine parameter definitions.

FANUC
Robotics

- *i*Pendant provides quick access to Internet/Intranet. Users can browse information that is available anywhere on the network.
- Users can develop process or application specific status pages and “Operator Panels” for the *i*Pendant in HTML using commercially available web development tools such as Microsoft’s FrontPage® or even online on the *i*Pendant itself. These pages can be used to display production status and statistics, charts and graphs, customized menus and site-specific help or diagnostics.

Hardware Features

- 6.4" color TFT backlit LCD display
- 640H x 480V x 256 colors
- Plug compatible with the standard robot controller monochrome teach pendant
- Lightweight - 1.25 kg
- Size approximately 300 mm H x 250 mm W x 80 mm D
- IP54 rated
- RIA 15.06/1999 compliant
- CE Mark available

Software Features and Requirements

- Requires robot controller software version 6.20 or later
- Supports HTML 3.2 and Javascript 1.1 for customization

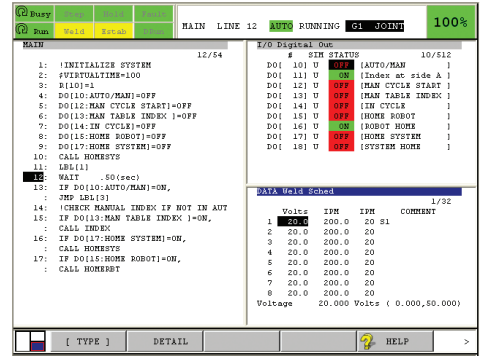

Multi-Window Display

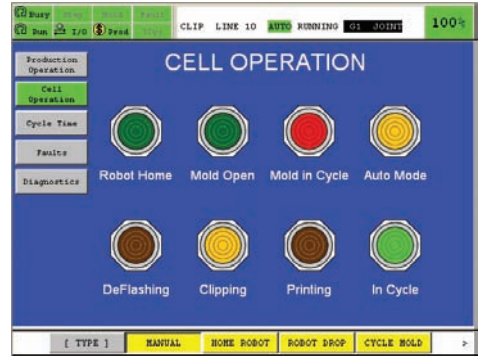

Custom Status Display

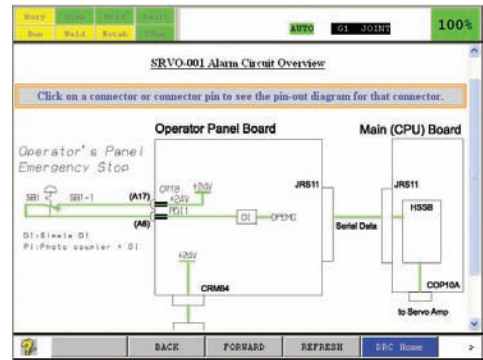

Troubleshooting Schematic Display

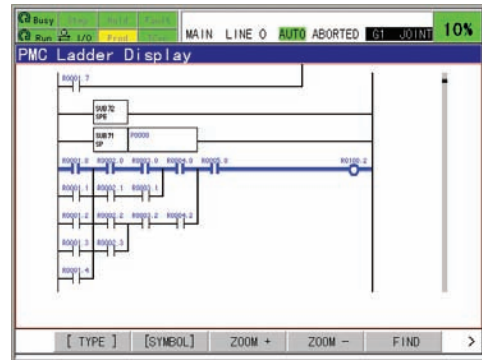

PMC Monitor Display

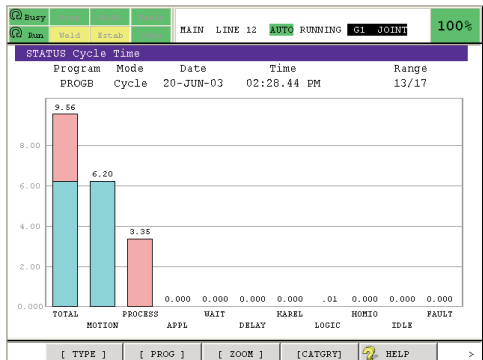

Cycle Time Analysis Display



Intelligent Robot Solutions



FANUC Robotics America, Inc.
 3900 W. Hamlin Road
 Rochester Hills, MI 48309-3253
 (248) 377-7000
 Fax (248) 377-7362

Charlotte, NC
 (704) 596-5121

Toronto, Canada
 (905) 812-2300

Chicago, IL
 (847) 898-6000

Montréal, Canada
 (450) 492-9001

For sales or technical information, call:
 1-800-iQ-ROBOT • 1-800-47-ROBOT

Cincinnati, OH
 (513) 754-2400

Aguascalientes, Mexico
 52 (449) 922-8000

Los Angeles, CA
 (949) 595-2700

Sao Paulo, Brazil
 (55) (11) 3619-0599

marketing@fanucrobotics.com
 fanucrobotics.com

Toledo, OH
 (419) 866-0788