

Motoman[®] NX100 Controller

ArcWorld[®]-1200 DRC System Manual

Part Number: 150312-2
Revision 1

MOTOMAN
YASKAWA company

600 Liberty Lane

West Carrollton, OH 45449

TEL: 937.847.6200

FAX: 937.847.6277

24-Hour Support: 937.847.3200



Everything for your HMI running

✉ sales@vicpas.com

☎ +86-15876525394

www.motoman.com
info@motoman.com

The information contained within this document is the proprietary property of Motoman, Inc., and may not be copied, reproduced or transmitted to other parties without the expressed written authorization of Motoman, Inc.

©2005 by MOTOMAN®
All Rights Reserved

Because we are constantly improving our products, we reserve the right to change specifications without notice.

MOTOMAN® is a registered trademark of YASKAWA Electric Manufacturing.



Everything for your HMI running

✉ sales@vicpas.com

☎ +86-15876525394

Table of Contents

Chapter 1	
Introduction	1
1.1 About This Document	1
1.2 System Overview	2
1.2.1 System Layout	3
1.2.2 Major Components	3
1.2.3 Optional Equipment	3
1.3 Reference Documentation	4
1.4 Customer Support Information	4
Chapter 2	
Safety	5
2.1 Introduction	5
2.2 Standard Conventions	6
2.3 General Safeguarding Tips	6
2.4 Mechanical Safety Devices	6
2.5 Installation Safety	7
2.6 Programming, Operation, and Maintenance Safety	7
Chapter 3	
Equipment Description	9
3.1 Robot Description	9
3.2 NX100-DRC Controller	9
3.3 Programming Pendant	10
3.4 Operator Station	12
3.4.1 Operator Station Function – Cycle Start/Cycle Latched	12
3.4.2 Operator Station Function – Emergency Stop (E-Stop)	13
3.4.3 Operator Station Function – Robot Hold	13
3.4.4 Operator Station Function – Alarm	13
3.4.5 Operator Station Function – Positioner Auto / Manual	13
3.4.6 Operator Station Function – Start	13
3.4.7 Operator Station Function – Reset	13
3.4.8 Operator Station Function – Servo ON	13
3.5 MR-300 Positioner	14
3.6 Welding Equipment	15
3.6.1 Welding Power Sources	15
3.6.2 Wire Feeder	15
3.6.3 GMAW Torch	15



3.7 Safety Features	15
3.7.1 Welding Arc Protection	16
3.7.2 Safety Fencing	16
3.7.3 Safety Light Curtains	16
3.7.4 Emergency Stop (E-Stop)	16
3.7.5 Programming Pendant ENABLE Switch	17
3.7.6 Emergency Braking System	17
3.7.7 Interlocked Work Cell Doors	17
Chapter 4	
Installation	19
4.1 Required Materials	19
4.1.1 Customer-Supplied Items	19
4.1.2 Recommended List of Hand Tools and Equipment	20
4.2 Site Preparation	20
4.3 Installing and Levelling the Robot / Positioner Common Base	21
4.4 Installing the NX100-DRC / Welding Power Source Common Base	23
4.5 Installing the Operator Station Pedestal	24
4.6 Installing the Light Curtains	25
4.6.1 Installation	25
4.6.2 Light Curtain Alignment	25
4.6.3 Anchoring Light Curtain Fence Panels	25
4.7 Removing the Robot Shipping Bracket	26
4.8 Cable Connections	27
4.8.1 Connection to Earth Ground	27
4.8.2 Connection to Local Electrical Service	28
4.9 Safety / Operation Check	29
4.10 Installation of Tooling and Fixtures	30
Chapter 5	
Operation	31
5.1 Programming	31
5.2 Sweeping the Positioner	31
5.3 Daily Operation	32
5.3.1 Start-Up	32
5.3.2 Move Robots to HOME Position	33
5.3.3 Select Master Job	33
5.3.4 Operation Cycle	34
5.3.5 Standard Shutdown	34
5.4 System Recovery	34
5.4.1 Alarms and Errors	35
5.4.1.1 Error Mes	35



5.4.1.2 Minor Alarms	35
5.4.1.3 Major Alarms	35
5.4.2 E-Stop Recovery	36
5.4.3 Shock Sensor Recovery	36
5.4.4 Brake Release	37
Chapter 6	
Maintenance	39
Appendix A	
Anchoring	41
Index	43



NOTES



Everything for your HMI running

✉ sales@vicpas.com

☎ +86-15876525394

Chapter 1

Introduction

1.1 About This Document

This System Manual is delivered with the ArcWorld®-1200 DRC system to provide a “first look” and overview of the complete Motoman ArcWorld®-1200 DRC robotic arc welding system. You should read and understand this System Manual before moving on to the more detailed documentation that is included with your ArcWorld®-1200 DRC system. Although basic in content, the System Manual is intended for personnel who have received operator training from Motoman, and who are familiar with the operation of this particular Motoman system. For more detailed information on any specific component or peripheral of the ArcWorld®-1200 DRC system, please review the full documentation package that is included with your ArcWorld®-1200 DRC system (refer to Section 1.3).

This System Manual contains the following chapters:

CHAPTER 1 – INTRODUCTION

This chapter provides general information about the ArcWorld®-1200 DRC and its components, a list of reference documents, and customer service contact information.

CHAPTER 2 – SAFETY

This chapter provides general information regarding the safe installation, maintenance, and operation of the ArcWorld®-1200 DRC system.

CHAPTER 3 – DESCRIPTION OF EQUIPMENT

This chapter provides a description of the major components of the ArcWorld®-1200 DRC system.

CHAPTER 4 – INSTALLATION

This chapter provides instructions for installation of the ArcWorld®-1200 DRC system.

CHAPTER 5 – OPERATION

This chapter provides an overview of ArcWorld®-1200 DRC system operation, including start-up, loading, normal operations, fault recovery, and system shutdown.

CHAPTER 6 – MAINTENANCE

This chapter provides a listing of preventive maintenance requirements for certain components of the ArcWorld®-1200 DRC system.

APPENDIX A – ANCHOR REQUIREMENTS

Appendix A gives recommended anchoring hardware specifications and foundation requirements for all of the equipment that is part of the ArcWorld®-1200 DRC system.



1.2 System Overview

The ArcWorld[®]-1200 DRC system provides a complete arc welding solution in a standardized configuration (see Figure 1). The system is designed around two Motoman EA1400N robots, an NX100-DRC controller package, two welding power sources, and an MR-300 rotary positioner. The rotary positioner allows an operator to prepare and set-up parts on one side of the positioner, while the robots weld on the other side of the positioner.

Refer to Section 3.2 for a more detailed description of the features and advantages of the DRC configuration.

The ArcWorld[®]-1200 DRC system features a total safety environment that meets or exceeds the requirements of the ANSI/RIA R15.06 standard, and is designed to safeguard both personnel and equipment. Heavy-gauge wire mesh safety fencing prevents unintended entry of personnel into the work cell while it is in operation. Arc curtains cover the wire mesh fencing to attenuate the amount of arc radiation that escapes the work cell during the welding operations. Dual-interlocked access doors, one on each side of the work cell, provide convenient access to equipment while providing a safety interlock to disable all equipment should either of the doors be opened while the robots are active. A dual-channel, safety light curtain system provides a “sensing field” in front of the rotary positioner to protect the operator. Rotary positioner motion is prevented whenever an operator is in a position to disrupt the sensing field of the light curtain system. In addition, maximum robot travel is physically limited by an S-axis “hard stop” at the base of each robot.

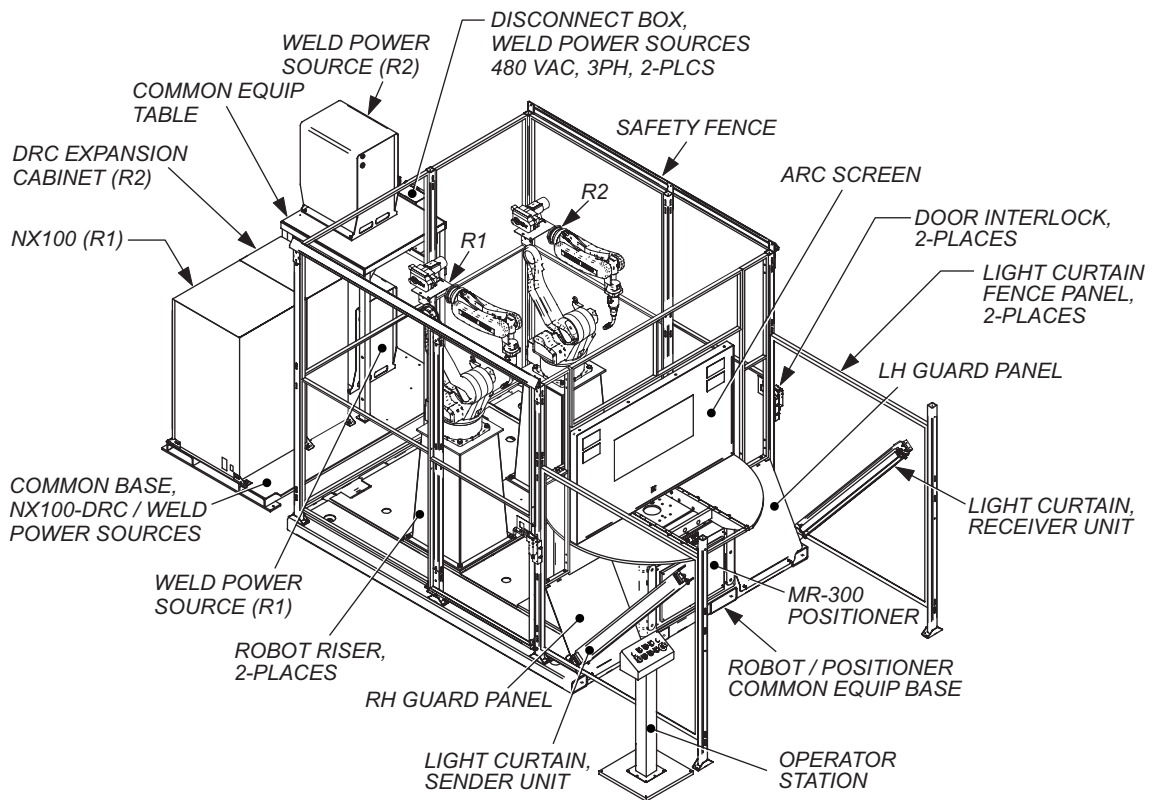

Figure 1 System Layout – ArcWo



1.2.1 System Layout

Two EA1400N manipulators (robots), an MR-300 180° rotary positioner, and heavy-gauge wire mesh safety fencing all share a common steel base for ease of installation and assurance of proper alignment between the robots and rotary positioner. The wire mesh safety fencing completely surrounds the ArcWorld®-1200 DRC work cell. The NX100-DRC robot controller shares a common platform with the welding power sources. This equipment platform is located outside of, and to the rear of, the work cell. This arrangement allows most of the component wiring interconnects to be pre-wired at the factory, thus reducing the amount of point-to-point wiring required of the customer. All operator controls, including those on the Programming Pendant, NX100-DRC controller, welding power supplies, and Operator Station pedestal are accessible from outside the ArcWorld®-1200 DRC work cell.

1.2.2 Major Components

The ArcWorld®-1200 DRC system includes the following major components:

- Two Motoman EA1400N manipulators (robots)
- One NX100-DRC robot controller assembly
- One MR-300 180° rotary positioner
- One Programming Pendant (located on the NX100-DRC controller)
- Operator Station pedestal
- Welding equipment (for each robot):
 - Welding power supply
 - Welding torch (air-cooled)
 - Wire feeder
 - Applicable welding interface
 - Torch mount
- Safety equipment:
 - Heavy gauge, wire-mesh safety fencing
 - Arc curtains (cover the safety fencing)
 - Dual-channel, interlocked safety light curtain system
 - Dual-channel, interlocked work cell entry doors
 - Steel arc screen on the MR-300 rotary positioner

1.2.3 Optional Equipment

The following optional equipment is available for use with the ArcWorld®-1200 DRC system:

- Torch cleaner
- Wire cutter
- Water-cooled torch (with water circulator)
- TouchSense (starting point detection)
- ComArc (seam tracking)



1.3 Reference Documentation

For additional information on individual components of the ArcWorld®-1200 DRC system, refer to the following documentation that is included with your delivered system:

- Motoman *EA1400N Manipulator Manual* (P/N 149208-1)
- Motoman *NX100 Operator's Manual for General Purpose* (P/N 150077-1)
- Motoman *NX100 Controller Manual* (P/N 149201-1)
- Motoman *NX100 Maintenance Manual* (P/N 150133-1)
- Motoman *NX100 Operator's Manual for Arc Welding* (P/N 149235-1)
- Motoman *NX100 Concurrent I/O Manual* (P/N 149230-1)
- Motoman *MR-300 Cast Base Positioner Manual* (P/N 147585-1)
- Motoman *NX100 Independent/Coordinated Control Function Manual* (P/N 149648-1)
- Motoman *INFORM User's Manual* (P/N 150078-1)
- Vendor manuals for system components not manufactured by Motoman

1.4 Customer Support Information

If you need assistance with any aspect of your ArcWorld®-1200 DRC system, please contact Motoman Customer Support at the following 24-hour telephone number –

(937) 847-3200

For routine technical inquiries, you can also contact Motoman Customer Support at the following e-mail address –

techsupport@motoman.com

When using e-mail to contact Motoman Customer Support, please provide a detailed description of your issue, along with complete contact information. Please allow approximately 24 to 36 hours for a response to your inquiry.



Note: Please use e-mail for routine inquiries, only. If you have an urgent or emergency need for service, replacement parts, or information, you must contact Motoman Customer Support at the telephone number shown above.

Please have the following information ready before you call –

- Robot Type EA1400N
- System ArcWorld®-1200 DRC
- Primary Application Arc Welding
- Controller Type NX100-DRC
- Software Version Access this information on the Programming Pendant LCD display screen by accessing MAIN MENU ➔ SYSTEM INFO ➔ VERSION
- Robot Serial Number Located on robot data plate
- Robot Sales Order Number NX100 controller (R1) data plate



Chapter 2

Safety

2.1 Introduction

It is the purchaser's responsibility to ensure that all local, county, state, and national codes, regulations, rules, or laws relating to safety and safe operating conditions for each installation are met and followed.

We suggest that you review a copy of the ANSI/RIA National Safety Standard for Industrial Robots and Robot Systems. This information can be obtained from the Robotic Industries Association (RIA) by requesting document *ANSI/RIA R15.06-1999*. The address is as follows –

RoboticIndustriesAssociation
900VictorsWay
P.O.Box3724
AnnArbor,Michigan48106
734.994.6088 (VOICE)
734.994.3338 (FAX)
www.roboticsonline.com

Ultimately, the best safeguard is trained personnel. The user is responsible for providing personnel who are adequately trained to operate, program, and maintain the robot cell. **The robot must not be operated by personnel who have not been trained!**

We recommend that all personnel who intend to operate, program, repair, or use the robot system be trained in an approved Motoman training course and become familiar with the proper operation of the system.

This safety chapter addresses the following –

- Standard Conventions (Section 2.2)
- General Safeguarding Tips (Section 2.3)
- Mechanical Safety Devices (Section 2.4)
- Installation Safety (Section 2.5)
- Programming, Operation, and Maintenance Safety (Section 2.6)

2.2 Standard Conventions

This manual includes the following alerts – in descending order of severity – that are essential to the safety of personnel and equipment. As you read this manual, pay close attention to these alerts to insure safety when installing, operating, programming, and maintaining this equipment.



DANGER!

Information appearing in a **DANGER** concerns the protection of personnel from the immediate and imminent hazards that, if not avoided, will result in immediate, serious personal injury or loss of life in addition to equipment damage.



WARNING!

Information appearing in a **WARNING** concerns the protection of personnel and equipment from potential hazards that can result in personal injury or loss of life in addition to equipment damage.



CAUTION!

Information appearing in a **CAUTION** concerns the protection of personnel and equipment, software, and data from hazards that can result in minor personal injury or equipment damage.



Note: Information appearing in a Note provides additional information which is helpful in understanding the item being explained.

2.3 General Safeguarding Tips

All operators, programmers, plant and tooling engineers, maintenance personnel, supervisors, and anyone working near the robot must become familiar with the operation of this equipment. All personnel involved with the operation of the equipment must understand potential dangers of operation. General safeguarding tips are as follows –

- Improper operation can result in personal injury and/or damage to the equipment. Only trained personnel familiar with the operation of this robot, the operator's manuals, the system equipment, and options and accessories should be permitted to operate this robot system.
- Do not enter the robot cell while it is in automatic operation. Programmers must have the teach pendant when they enter the robot cell.
- Improper connections can damage the robot. All connections must be made within the standard voltage and current ratings of the robot I/O (Inputs and Outputs).
- The robot must be placed in Emergency Stop (E-Stop) mode whenever it is not in use.
- In accordance with ANSI/RIA R15.06-1999, section 4.2.5, Sources of Energy, use lockout/tagout procedures during equipment maintenance. Refer also to Section 1910.147 (29CFR, Part 1910), Occupational Safety and Health Standards for General Industry (OSHA).

2.4 Mechanical Safety Devices

The safe operation of the robot, positioner, auxiliary equipment, and system is ultimately the user's responsibility. The conditions under which the equipment will be operated safely should be reviewed by the user. The user must be aware of applicable international codes, ANSI/RIA R15.06-1999 safety

standards, and other local codes that may pertain to the installation and use of industrial equipment. Additional safety measures for personnel and equipment may be required depending on system installation, operation, and/or location. The following safety equipment is provided as standard –

- Safety fences and barriers
- Light curtains and/or safety mats
- Door interlocks
- Emergency stop (E-Stop) palm buttons located on Operator Station, robot controller, and Programming Pendant

Check all safety equipment frequently for proper operation. Immediately repair or replace any non-functioning safety equipment.

2.5 Installation Safety

Safe installation is essential for protection of people and equipment. The following suggestions are intended to supplement, but not replace, existing federal, local, and state laws and regulations. Additional safety measures for personnel and equipment may be required depending on system installation, operation, and/or location. Installation tips are as follows –

- Be sure that only qualified personnel familiar with national codes, local codes, and ANSI/RIA R15.06-1999 safety standards are permitted to install the equipment.
- Identify the work envelope of each robot with floor markings, signs, and barriers.
- Position all controllers outside the robot work envelope.
- Whenever possible, install safety fences to protect against unauthorized entry into the work envelope.
- Eliminate areas where personnel might get trapped between a moving robot and other equipment (pinch points).
- Provide sufficient room inside the work cell to permit safe teaching and maintenance procedures.

2.6 Programming, Operation, and Maintenance Safety

All operators, programmers, plant and tooling engineers, maintenance personnel, supervisors, and anyone working near the robot must become familiar with the operation of this equipment. Improper operation can result in personal injury and/or damage to the equipment. Only trained personnel familiar with the operation, manuals, electrical design, and equipment interconnections of this robot should be permitted to program, operate, and maintain the system. All personnel involved with the operation of the equipment must understand potential dangers of operation.

- Inspect the robot and work envelope to be sure no potentially hazardous conditions exist. Be sure the area is clean and free of water, oil, debris, etc.
- Be sure that all safeguards are in place. Check all safety equipment for proper operation. Repair or replace any non-functioning safety equipment immediately.
- Do not enter the robot work envelope during automatic operation. Be sure that only the person holding the Programming Pendant is in the cell.

- Check the E-Stop button on the Programming Pendant for proper operation before programming. The robot must be placed in Emergency Stop (E-Stop) mode whenever it is not in use.
- Back up all programs and jobs onto suitable media before program changes are made. To avoid loss of information, programs, or jobs, a backup must always be made before any service procedures are done and before any changes are made to options, accessories, or equipment.
- Any modifications to PART 1, System Section, of the robot controller concurrent I/O program can cause severe personal injury or death, as well as damage to the robot! Do not make any modifications to PART 1, System Section. Making changes without the written permission of Motoman will VOID YOUR WARRANTY!
- Some operations require standard passwords and some require special passwords. Special passwords are for Motoman use only. YOUR WARRANTY WILL BE VOID if you use these special passwords.
- The robot controller allows modifications of PART 2, User Section, of the concurrent I/O program and modifications to controller parameters for maximum robot performance. Great care must be taken when making these modifications. All modifications made to the controller will change the way the robot operates and can cause severe personal injury or death, as well as damage the robot and other parts of the system. Double-check all modifications under every mode of robot operation to ensure that you have not created hazards or dangerous situations.
- Check and test any new or modified program at low speed for at least one full cycle.
- This equipment has multiple sources of electrical supply. Electrical interconnections are made between the controller and other equipment. Disconnect and lockout/tagout all electrical circuits before making any modifications or connections.
- Do not perform any maintenance procedures before reading and understanding the proper procedures in the appropriate manual.
- Use proper replacement parts.
- Improper connections can damage the robot. All connections must be made within the standard voltage and current ratings of the robot I/O (Inputs and Outputs).



Everything for your HMI running

✉ sales@vicpas.com
☎ +86-15876525394

MOTOMAN
a YASKAWA company

Chapter 3

Equipment Description

3.1 Robot Description

The ArcWorld®-1200 DRC system uses two Motoman EA1400N six-axis robots. Each EA1400N robot is specifically designed for arc welding applications. Each robot has a payload capability of 3 kg (6.6 lbs.) and features a horizontal reach of 1388-mm (54.6 inches). Each robot features a relative positioning accuracy of ± 0.08 mm (± 0.003 inch). The EA1400N robot has an internal cabling design that provides high flexibility and streamlines the robot profile, thus allowing access into confined spaces. The robot's B-axis (Pitch/Yaw) features an expanded range of motion that improves circumferential welding on cylindrical work pieces. The T-axis (Twist) can rotate the welding torch ± 360 degrees without cable interference.

For additional information on the Motoman EA1400N robots, please refer to the *EA1400N Manipulator Manual* that is included with your ArcWorld®-1200 DRC system (refer to Section 1.3).

3.2 NX100-DRC Controller

The ArcWorld®-1200 DRC system features one NX100-DRC controller that consists of one NX100 controller mated to an expansion cabinet (see Figure 2). This combination provides the same functionality of two full-size controllers, while reducing the overall width by 250 mm (9.8 in) when compared to two, full-size NX100 controllers. This configuration also reduces the cost to the operator by eliminating certain redundant components.

Through specific cable interconnections (internal to the NX100-DRC), the NX100-DRC is configured as controller R1 and controller R2 (see Figure 2). This configuration allows the two robots to operate as a dual system that takes advantage of all the unique functions available only in a dual system configuration. With the ArcWorld®-1200 DRC system, the full-size NX100 controller cabinet is designated R1, while the smaller, expansion cabinet is designated R2.

In addition to controlling the movement of the two robots, the NX100-DRC also controls the two welding power sources, the MR-300 rotary positioner, and provides the signals necessary to operate the two welding systems.



The NX100-DRC controller features an embedded real-time operating system (RTOS) and is programmed with the Motoman INFORM programming language.

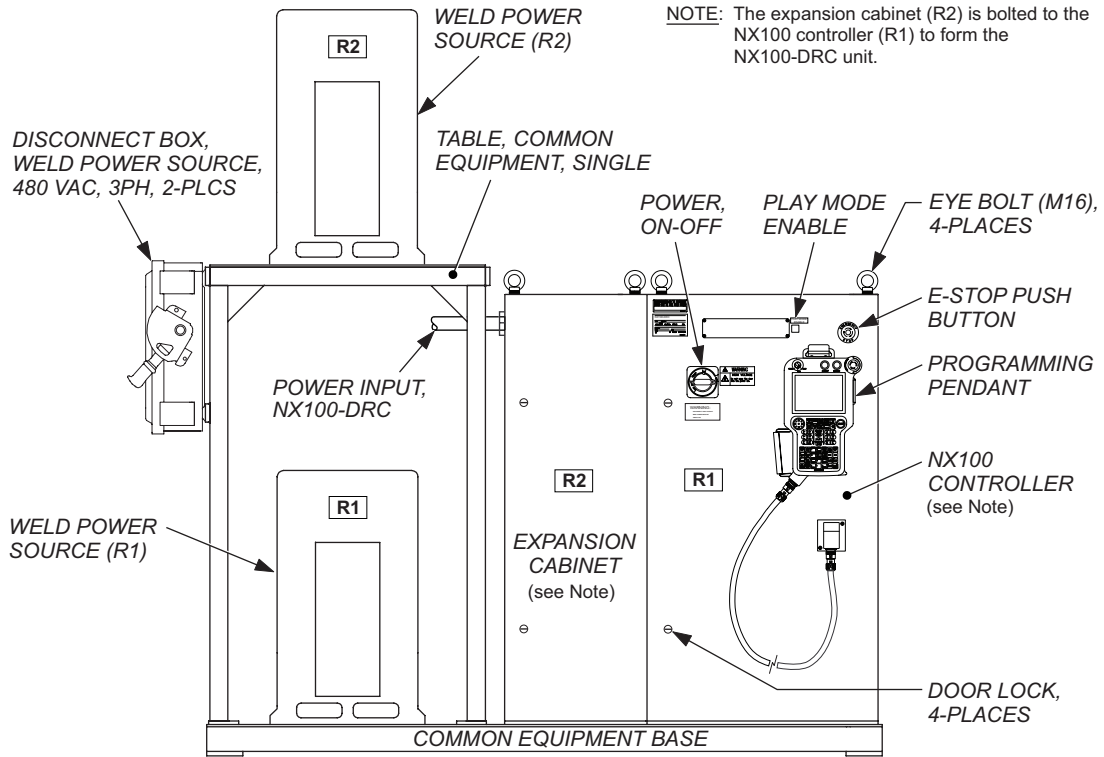
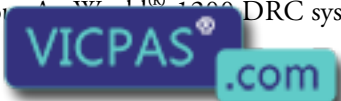

Figure 2 NX100-DRC Controller

3.3 Programming Pendant

The Programming Pendant (see Figure 3) provides the primary means of programmer/operator interaction with the ArcWorld®-1200 DRC system. The pendant features the Windows® CE operating system and displays information on a 6½ -inch, color LCD, touch-screen display (640 X 480 VGA). The pendant also incorporates a CompactFlash® card slot for program backups. An optional on-line troubleshooting guide for expert system maintenance is also available on the pendant display. The Programming Pendant provides icon-driven system programming. It also features a menu-driven interface to simplify operator interaction with the robots. Most operator controls are located on the Programming Pendant. This allows remote installation of the NX100-DRC controller. By using the Programming Pendant, the operator can teach robot motion; perform programming, editing, maintenance, and diagnostic functions; and enable / disable Operator Station control of the ArcWorld®-1200 DRC system. For detailed information on the pendant programming keys, programming functions, and display functions, please refer to the *NX100 Operator's Manual for Arc Welding* that is included with your ArcWorld®-1200 DRC system (refer to Section 1.3).



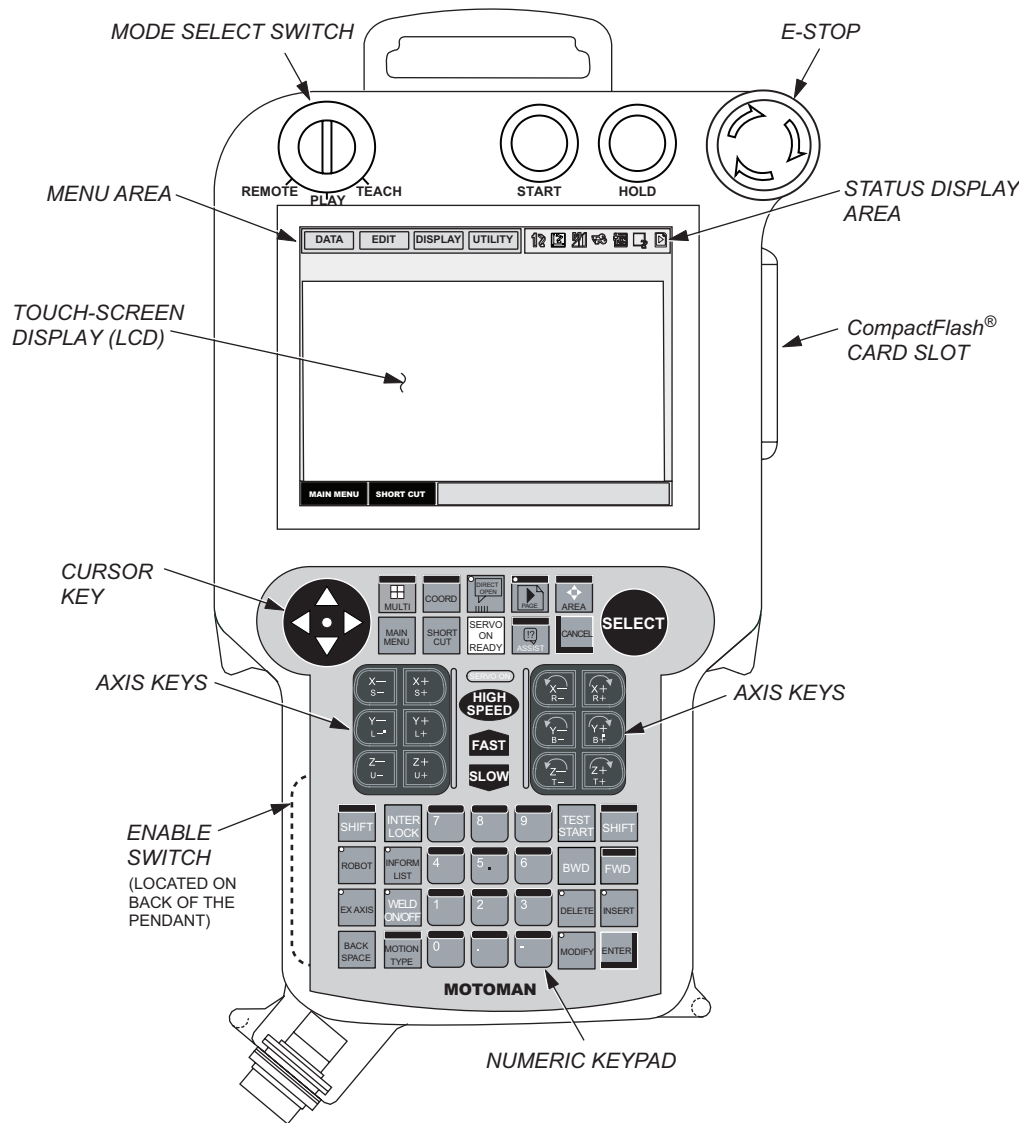



Figure 3 NX100-DRC Programming Pendant

 *Note: The Programming Pendant LCD display goes dark after a few minutes of inactivity. Press any key to restore screen.*

 *Note: Operator Station ENABLE/DISABLE is accomplished with the Programming Pendant MODE SELECT SWITCH. To transfer control of the ArcWorld®-1200 DRC system to the Operator Station, set the Programming Pendant MODE SELECT SWITCH to REMOTE. The Operator Station ENABLE/DISABLE function cannot be selected at the Operator Station.*



3.4 Operator Station

The Operator Station (see Figure 4) includes a NEMA enclosure on a stand-alone pedestal. See Figure 1 for location of the Operator Station Pedestal in relation to other components of the ArcWorld®-1200 DRC system.

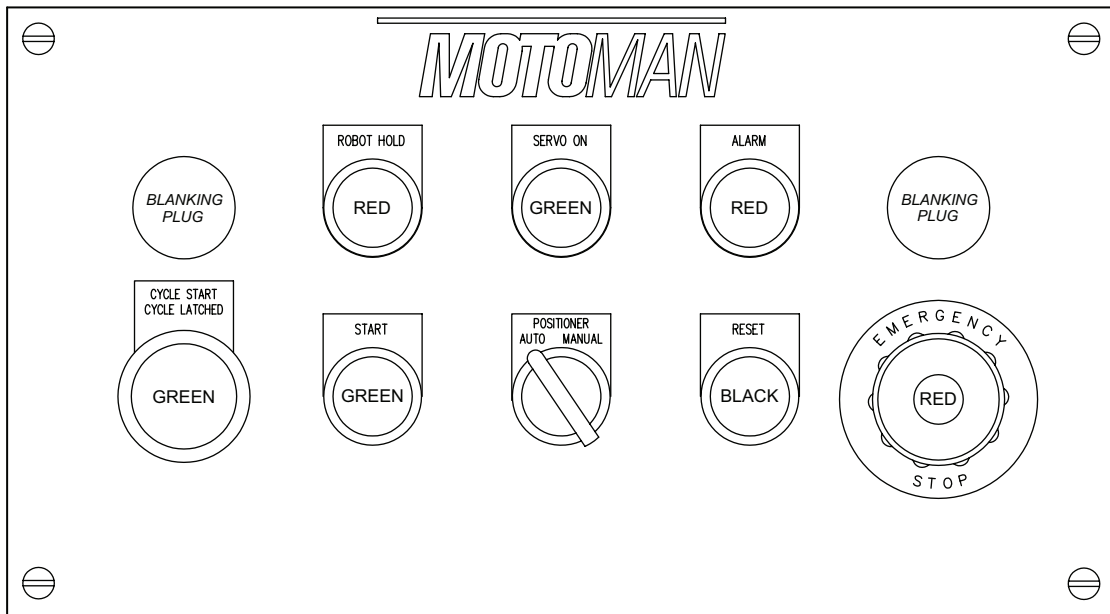

Figure 4 Operator Station Controls

3.4.1 Operator Station Function – Cycle Start/Cycle Latched



WARNING!

The operation of the **CYCLE START** button is dependent on the structure of the Master Job. Any alteration of the Master Job could result in injury to personnel or damage to equipment.

Pushing the green **CYCLE START/CYCLE LATCHED** push button, located on the Operator Station, initiates a positioner sweep cycle if the robot is in the HOME (Safe) position. If the **CYCLE START/CYCLE LATCHED** push button is pressed while the robot is still welding, or otherwise not in the HOME (Safe) position, the **CYCLE START** command is “latched” into (stored in) the NX100-DRC controller circuitry. When the robot returns to the HOME (Safe) position, the “latched” **CYCLE START** command is executed and the positioner sweeps. Circuitry in the NX100-DRC controller prevents the positioner from continuously cycling, should the operator depress and hold the **CYCLE START/CYCLE LATCHED** push button.



3.4.2 Operator Station Function – Emergency Stop (E-Stop)

Pressing the Operator Station E-Stop push button initiates an emergency stop (E-Stop). Refer to Section 3.7.4 for a discussion of the E-Stop function, and procedures for recovering the ArcWorld®-1200 DRC system from the emergency stop (E-Stop) condition.

3.4.3 Operator Station Function – Robot Hold

Pressing the red ROBOT HOLD button stops robot operation and interrupts the job until the operator presses the green START button to resume operation. Operation resumes at the point in the program where the ROBOT HOLD state was initiated.

3.4.4 Operator Station Function – Alarm

A red ALARM lamp illuminates to indicate that the NX100-DRC controller has encountered an alarm condition.

3.4.5 Operator Station Function – Positioner Auto / Manual

The POSITIONER AUTO/MANUAL switch is used to select AUTO or MANUAL mode for the MR-300 rotary positioner. With the switch set to the AUTO position, the robot welds the parts immediately after the positioner sweeps. With the switch set to the MANUAL position, the robot does not immediately start to weld after the positioner sweeps. The robots remains in the HOME position.



Note: The POSITIONER AUTO / MANUAL signal depends upon the structure of the Master job.

3.4.6 Operator Station Function – Start

Pressing the green START button starts the current, active job. The Operator Station must be enabled and servo power must be ON for the START button to function.

3.4.7 Operator Station Function – Reset

The black RESET button is used to clear a minor alarm or error condition.

3.4.8 Operator Station Function – Servo ON

The green SERVO-ON push button turns servo power ON when the robot is in PLAY mode and the Operator Station is enabled.



3.5 MR-300 Positioner

The MR-300 positioner is part of the ArcWorld[®]-1200 DRC system (Figure 1 and Figure 5). It is mounted on the same common equipment base as the EA1400N robots and the wire mesh safety fencing. The MR-300 is a high-speed rotary positioner that features controlled rotary motion and a 300 kg (661 lb) payload capacity per side. The standard configuration utilizes a brushless AC drive motor plus gear reducer, a 1525 mm (60-inch) circular table top, and a housing. A steel arc screen divides the table top, providing two semicircular work areas (Side A and Side B). The steel arc screen creates a barrier that safeguards the operator from arc radiation and sparks produced during the welding operation. The MR-300 uses a rotary motion to sweep each side of the circular turntable 180° from the operator's loading zone, into the robot's work zone, and back to the operator again. The positioner can accept optional external axis control for coordinated motion between the positioner and the robots.



WARNING!

Do not operate the MR-300 positioner unless the arc screen is in place. Operation of the positioner without the arc screen in place can result in burns or serious eye damage for the operator.

For detailed positioner information, including illustrated parts lists, load capabilities, and dimensions, refer to the *MR-300 Cast Base Positioner Manual* that is included with your ArcWorld[®]-1200 DRC system (Refer to Section 1.3).



Note: The customer shall supply all tooling and fixtures for the MR-300 positioner.



Note: Motoman recommends application of a corrosion/rust preventive compound to tooling and fixtures located in a high-humidity environment.

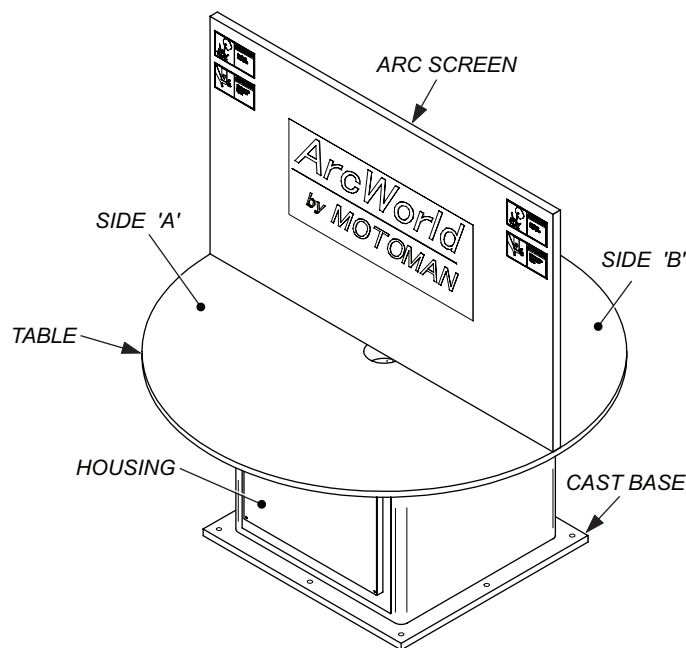

Figure 5 MR-300 Positioner



3.6 Welding Equipment

In its standard configuration, the ArcWorld®-1200 DRC system includes a welding power source, wire feeder, torch, and torch mount for each of the two EA1400N robots. Optional equipment – water-cooled torch, water circulators, ComArc seam tracking units, and torch tenders – may also be included with your ArcWorld®-1200 DRC system.

3.6.1 Welding Power Sources

Motoman offers various brands and types of welding power sources. The actual brand and type of welding power source supplied with the ArcWorld®-1200 DRC system depends on the customer's specific application and preference. For specific information on the welding power sources supplied with your ArcWorld®-1200 DRC system, refer to the welding power source vendor manual that is included with your system (refer to Section 1.3.).

3.6.2 Wire Feeder

A welding wire feeder is mounted on the upper arm (U-Axis) of each EA1400N robot. The wire feeder is the “4-roll” type and provides reliable wire feeding at rates up to 750 inches per minute (ipm). An integral gas valve provides fast shielding gas response time. Interchangeable feed rolls are used to accommodate different wire gauges and wire types. For additional information on how the wire feeder is mounted to the robot upper arm, including allowable load and installation position, refer to the wire feeder documentation that is included with your ArcWorld®-1200 DRC system (refer to Section 1.3).

3.6.3 GMAW Torch

The ArcWorld®-1200 DRC system uses either an air-cooled or a water-cooled robotic/automatic GMAW torch for each robot. These are heavy-duty torches designed for quick replacement and minimum robot reprogramming. The GMAW torch is installed at the end of the robot wrist flange. For applications that use the optional water-cooled torch, the ArcWorld®-1200 DRC system includes a water circulator kit for each robot. For additional information on the torches that are supplied with your system, refer to the documentation that is included with your ArcWorld®-1200 DRC system (refer to Section 1.3).

3.7 Safety Features

The ArcWorld®-1200 DRC system includes a total safety environment. If you comply with all standard safety precautions, the safety equipment helps to ensure safe operation of the robot work cell.



Note: The customer is responsible for determining that the safeguards provided with the ArcWorld®-1200 DRC system are adequate for their plant conditions. The customer must also ensure that all safeguards are maintained in working order.



3.7.1 Welding Arc Protection

Two forms of welding arc protection are part of the ArcWorld®-1200 DRC system –

- a steel arc screen on the MR-300 rotary positioner
- arc curtains that are attached to the steel mesh safety fencing

The steel arc screen on the MR-300 rotary positioner protects the operator from arc radiation and sparks that result from the welding operation (see Figure 1 and Figure 5).



WARNING!

Although safety fence arc curtains block dangerous arc radiation, never look directly at the arc without protective eye wear.

Arc curtains cover the steel mesh safety fencing that surrounds the entire work cell. The curtains provide protection from arc flash and reduce the amount of ultra-violet radiation that escapes from the work cell during welding operations.

3.7.2 Safety Fencing

The heavy-gauge steel mesh safety fencing that is provided with the ArcWorld®-1200 DRC system attaches to the robot/positioner common base and encloses the entire work cell. It forms a physical barrier that prevents personnel from entering the work cell during automatic operation.

3.7.3 Safety Light Curtains

The safety light curtain system consist of two units (a SEND unit and a RECEIVE unit) that emit and receive infrared light to create an invisible protective field in front of the MR-300 positioner (see Figure 1). If an object or person penetrates the protective field while the positioner is sweeping, the light curtain system creates an E-Stop condition (refer to Section 3.7.4). The safety light curtain system incorporates a dual-channel safety feature that provides redundant circuitry to ensure fail-safe operation and a continuous field of coverage for the protected area in front of the positioner.

For additional information on the safety light curtain system, refer to the vendor documentation that is included with your ArcWorld®-1200 DRC system (refer to Section 1.3).

3.7.4 Emergency Stop (E-Stop)

E-Stop is a primary safety feature of the ArcWorld®-1200 DRC system. Work cell access door interlocks, a safety light curtain system, robot welding torch impact (collision) detection circuitry (refer to Section 3.6.3), and E-Stop push buttons can all trigger an E-Stop condition. An E-Stop condition immediately de-energizes the control system and activates the robot braking system (refer to Section 3.7.6). The E-Stop push buttons are used for an intentional shutdown of the ArcWorld®-1200 DRC system, and are installed at the following locations –

- Programming Pendant
- NX100 controller (R1)
- Operator Station



To resume operation after an E-Stop system shutdown, the operator must clear and reset the action that caused the E-Stop condition (refer to Section 5.4.2).

3.7.5 Programming Pendant ENABLE Switch

The ENABLE switch is part of the Programming Pendant, and provides a safety feature that controls servo power while the system is in TEACH mode (see Figure 6). When pressed in, this switch allows the operator to turn servo power ON. However, should the operator release the switch or grasp it too tightly, servo power is immediately removed, thus preventing further robot movement. For detailed information about the operation of the ENABLE switch, refer to the *NX100 Operator's Manual for Arc Welding* that is included with your ArcWorld®-1200 DRC system (refer to Section 1.3).

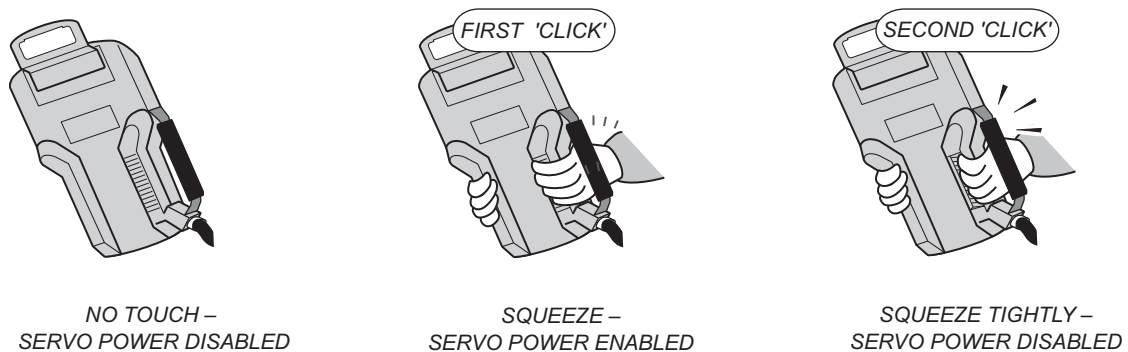

Figure 6 Programming Pendant ENABLE Switch – Location and Operation

3.7.6 Emergency Braking System

The robot incorporates a braking system that protects personnel from injury and prevents equipment damage if servo power is removed. Upon loss of servo power, the brake system activates to hold all robot axes in place. The brake system incorporates a feature that allows the operator to release the brake of a specific robot axis when drive power has been removed from the system. Brake release is accomplished with the Programming Pendant (refer to Section 5.4.4).

3.7.7 Interlocked Work Cell Doors

A redundant circuit safety interlock is installed on each of the two sliding work cell access doors (see Figure 1). Opening a work cell door while the robots are in PLAY mode triggers an E-Stop condition (refer to Section 3.7.4).



NOTES



Everything for your HMI running

✉ sales@vicpas.com

📞 +86-15876525394

Chapter 4

Installation



CAUTION!

The ArcWorld®-1200 DRC system should be installed by qualified personnel who are familiar with the installation and set-up of a robotic system.



CAUTION!

The ArcWorld®-1200 DRC system is not extremely fragile. It is, however, a sophisticated robotic system that can be damaged by rough handling. Be sure to handle all system components with care.

Two to three qualified technicians can install the ArcWorld®-1200 DRC system in a reasonable amount of time. Always comply with established safety procedures throughout the installation process (refer to Chapter 2).

4.1 Required Materials

All system components and most hardware required for installation of the ArcWorld®-1200 DRC system are included with your shipment. There are, however, some required items that the customer must supply (hand tools, special anchor bolts, etc.). These are not included with your shipment.

4.1.1 Customer-Supplied Items

- Welding gas supply
- Local electrical service
- Earth ground wires for EA1400N robots, NX100-DRC controller, and peripheral equipment.
- Earth ground rods and/or buried copper sheeting (quantity as required to achieve specified resistance-to-ground reading of 100 ohms or less)
- Chemical (optional) to increase conductivity of soil in the vicinity of the earth ground system.
- Welding wire
- Clean, dry air supply (15 scfm @ 90 psig) for torch tender or wire cutter options
- Forklift and/or overhead crane



4.1.2 Recommended List of Hand Tools and Equipment

- Safety glasses
- Face shield
- Gloves (heavy-duty leather recommended)
- Level (short and long)
- Ratchet handle (with 3/4-inch hex socket)
- Adjustable wrench (small and large)
- Hammer drill with appropriate concrete bits
- Phillips and flat-blade screwdrivers
- Hammer (dead-blow and steel)
- Hammer (non-marring)
- Socket set (SAE and Metric)
- Air-impact gun (with 3/4-inch hex socket)
- Open-end wrench set (SAE and Metric)
- Allen wrench set (SAE and metric)

4.2 Site Preparation



WARNING!

Be sure to allow for sufficient room for maintenance on the robots, NX100-DRC controller, and other peripheral equipment. Failure to observe this precaution could result in injury to personnel during system maintenance.

Procedure –

1. Clear floor space needed for the ArcWorld[®]-1200 DRC system (see Figure 7). Allow an additional 1.2 - 1.5 m (4 to 5 ft) on all sides of the work cell to facilitate installation.
2. Gather all customer-supplied items and required tools (refer to Section 4.1).

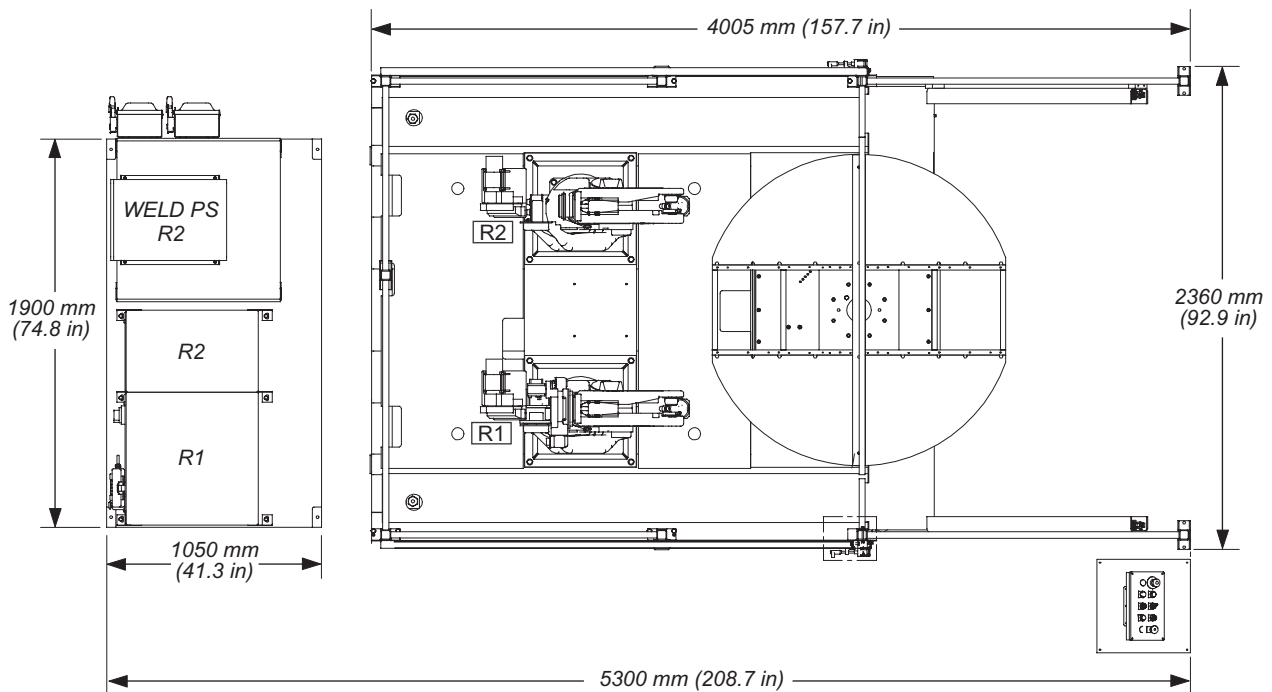

Figure 7 Plan View – Installation of the ArcWorld[®]-1200 DRC System



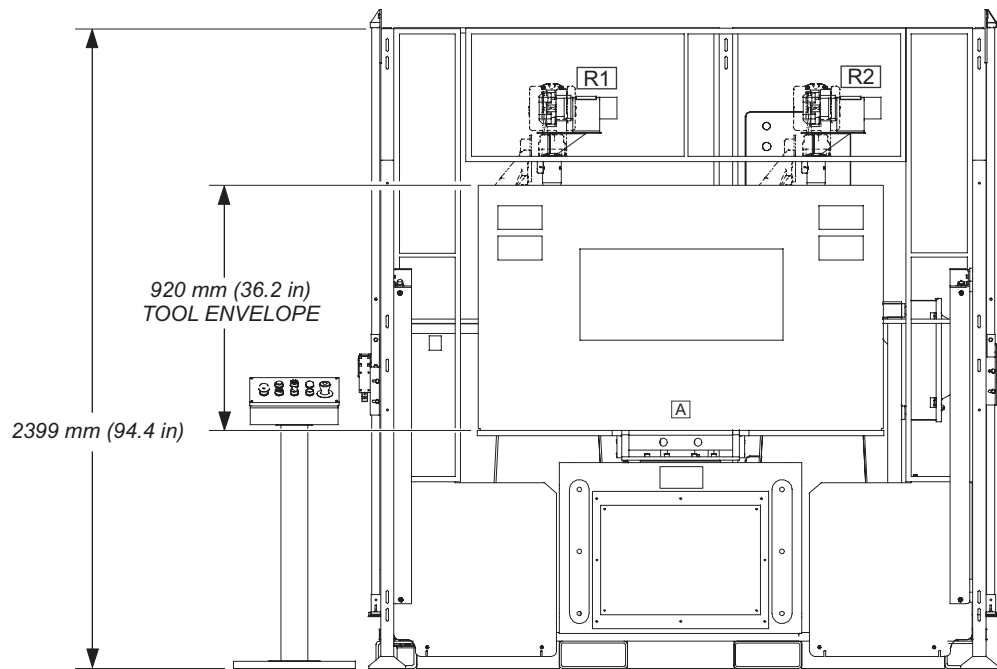

Figure 8 Elevation View – Installation Dimensions for the ArcWorld®-1200 DRC System

4.3 Installing and Levelling the Robot / Positioner Common Base

The robot/positioner common base and Operator Station are shipped on a wooden shipping skid. To install the robot/positioner common base, proceed as follows:



CAUTION!

Handle system components carefully. Some components can be damaged if dropped or otherwise handled roughly.

1. Unbolt the robot/positioner common base from the wooden shipping skid. The bolts that secure the common base to the wooden shipping skid go down through the hollow levelling screws and are threaded into the wooden shipping skid (see Figure 9). It may be necessary to hold the levelling screws in place with a suitable open-end wrench, while removing the shipping bolts.
2. Locate the Operator Station pedestal and set it aside in a secure location for later installation (refer to Section 4.5).



WARNING!

As shipped, the robot / positioner common base (with equipment) weighs approximately 2250 kg (4960 lbs). Make sure that your lifting devices (overhead crane, forklifts, etc) are rated to safely handle this load.



- Using an overhead crane, lift the common base from wooden shipping skid. Discard or recycle the wooden shipping skid.

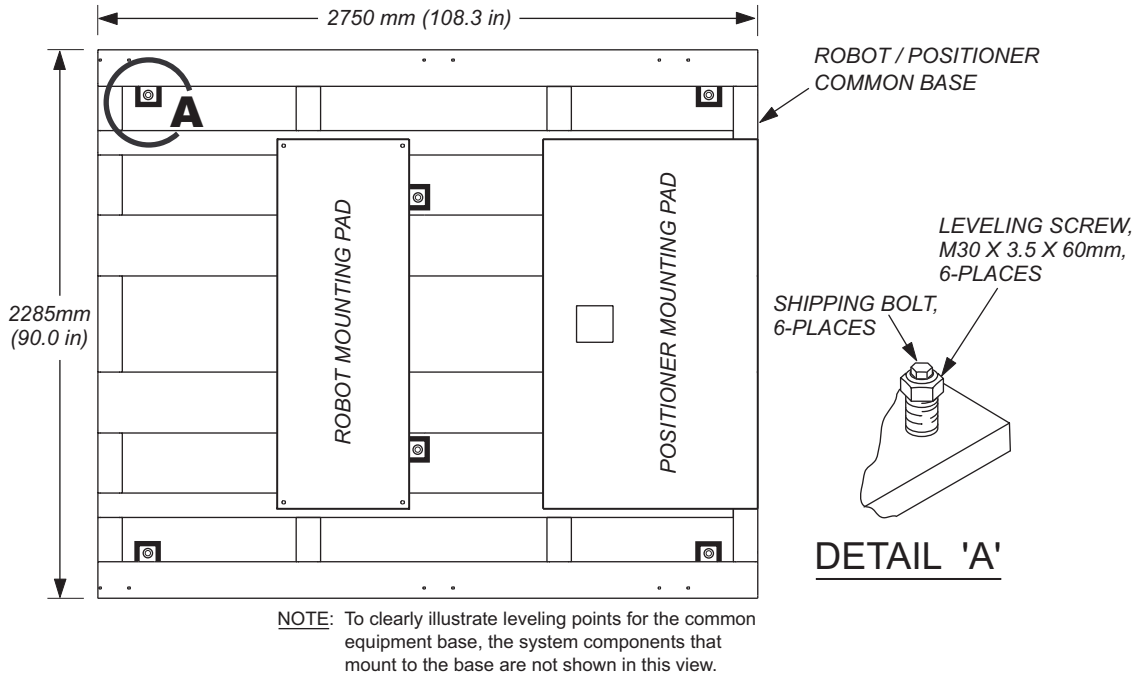

Figure 9 Stabilizing and Lag Points (Robot / Positioner Common Equipment Base)

- Place robot/positioner common base in position (see Figure 7).



Note: Make sure there is adequate room on all sides of the robot/positioner common base for the Operator Station, the light curtains, and the NX100-DRC/weld power source common base (see Figure 7).

- Carefully remove protective plastic wrapping from the robots, torches, and the positioner.
- Inspect the robots, torches, and positioner for shipping damage.



Note: If you notice any equipment damage, notify your shipping contractor as soon as possible.

- Use an M36 socket to loosen or tighten each levelling bolt to level the robot/positioner common base (see Figure 9).



CAUTION!

Be absolutely certain of the correct location for the robot/positioner common base before securing the base with anchor (lag) bolts.

- Secure the robot/positioner common base to the floor. Use a suitable concrete drill bit and special anchor (lag) bolts (refer to Appendix A for the correct drill bit and anchor bolt). Be sure to remove all concrete dust from the drilled hole before driving each anchor bolt.

4.4 Installing the NX100-DRC / Welding Power Source Common Base

The NX100-DRC controller, two welding power sources, two electrical service disconnect boxes (one for each welding power source), and a common equipment table for the welding power sources are mounted on a common base (see Figure 2 and Figure 10). As delivered to the customer, the common base is attached to wooden shipping blocks by four shipping bolts.

Procedure –

1. Separate the wooden shipping blocks from the common base by removing all four shipping bolts (see Figure 10).



WARNING!

As shipped, the NX100-DRC / Welding Power Sources common base (with equipment) weighs approximately 2000 kg (4409 lbs). Make sure that your lifting devices (overhead crane, forklifts, etc) are rated to safely handle this load.

2. After you remove the shipping bolts, use an overhead crane or forklift to lift the common base just enough to allow the wooden shipping blocks to be pushed out from under the common base. Discard or recycle the shipping blocks.
3. Place the common base in position behind the ArcWorld®-1200 DRC work cell (see Figure 7).
4. Remove protective plastic wrapping, cardboard, and other protective shipping material from the common base, and the ArcWorld®-1200 DRC components mounted to the common base.
5. Inspect the common base and all attached components for shipping damage.



Note: Notify your shipping contractor as soon as possible, if you notice any shipping damage.



CAUTION!

Be absolutely certain of the correct location for the NX100-DRC / Welding Power Sources common base before securing the base with anchor (lag) bolts.

6. Secure the common base to the floor. Use a suitable concrete drill bit and special anchor (lag) bolts (refer to Appendix A for correct drill bit and anchor bolt). Be sure to remove all concrete dust from the drilled hole before driving each anchor bolt.



Note: The lag bolts use the same holes in the common base as did the previously removed shipping bolts.

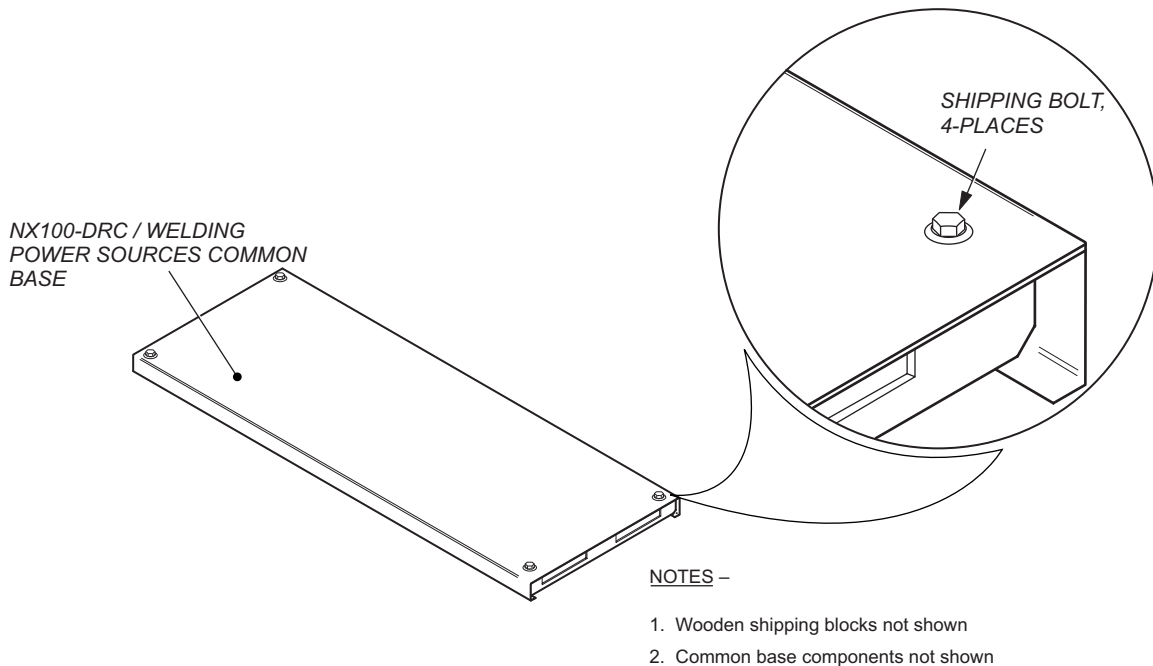

Figure 10 NX100-DRC / Weld Power Sources Common Base

4.5 Installing the Operator Station Pedestal

Procedure –

1. Locate Operator Station pedestal (previously put aside in secure location).
2. Carefully remove protective plastic wrapping from Operator Station pedestal.
3. Inspect the Operator Station pedestal for shipping damage.



Note: If you notice any equipment damage, notify your shipping contractor as soon as possible.

4. Place the Operator Station pedestal outside light curtain fence panels (see Figure 7 and Figure 8 for recommended location).



CAUTION!

Be absolutely certain of the correct location for the Operator Station pedestal before securing the pedestal with anchor (lag) bolts.

5. Secure the Operator Station pedestal to the floor. Use a suitable concrete drill bit and special anchor (lag) bolts (refer to Appendix A for correct drill bit and anchor bolt). Be sure to remove all concrete dust from the drilled hole before driving each anchor bolt.

4.6 Installing the Light Curtains

4.6.1 Installation

The light curtain components – the sender unit, the receiver unit, and the two fence panels to which the light curtain units are attached – are pre-assembled and secured inside the work cell for shipping. Refer to Figure 11 and install the light curtain assemblies to the work cell safety fencing as follows:

1. Remove both light curtain fence panels from their shipping position.
2. Install the light curtain fence panels to the wire mesh safety fencing. Use the three bolt holes located on the safety fence posts to mount the light curtain fence panels to the safety fencing (see Figure 11).



Note: The light curtains are oriented properly when the light curtain status indicator lamps (on each light curtain unit) are located closest to the floor.

3. The light curtain signal cables are secured and stowed under the base of the MR-300 rotary positioner prior to shipping. Locate those cables and attach them to the light curtain sender unit and receiver unit.

4.6.2 Light Curtain Alignment

The light curtain sender unit and receiver unit must be accurately positioned, relative to each other, to ensure correct operation. Complete alignment procedures are included in the light curtain documentation that is included with your ArcWorld®-1200 DRC system (refer to Section 1.3).

4.6.3 Anchoring Light Curtain Fence Panels

When the light curtain fence panels are correctly attached to the wire mesh safety fencing, perform the following steps to complete the installation of the light curtain fence panels –

1. Check alignment of light curtain fence panels. Each light curtain fence panel should be parallel to the safety fence panel to which it is attached. Adjust as required (see Figure 7).
2. Secure the safety light curtain fence panel posts to the floor (see Figure 7 and Figure 11). Use a suitable concrete drill bit and special anchor (lag) bolts (refer to Appendix A for correct drill bit and anchor bolt). Be sure to remove all concrete dust from the drilled hole before driving each anchor bolt.
3. After installing the anchor (lag) bolts, check the alignment of the light curtain sender unit and receiver unit, and adjust as necessary for correct operation. If necessary, refer to the safety light curtain documentation that is included with your ArcWorld®-1200 DRC system (refer to Section 1.3).



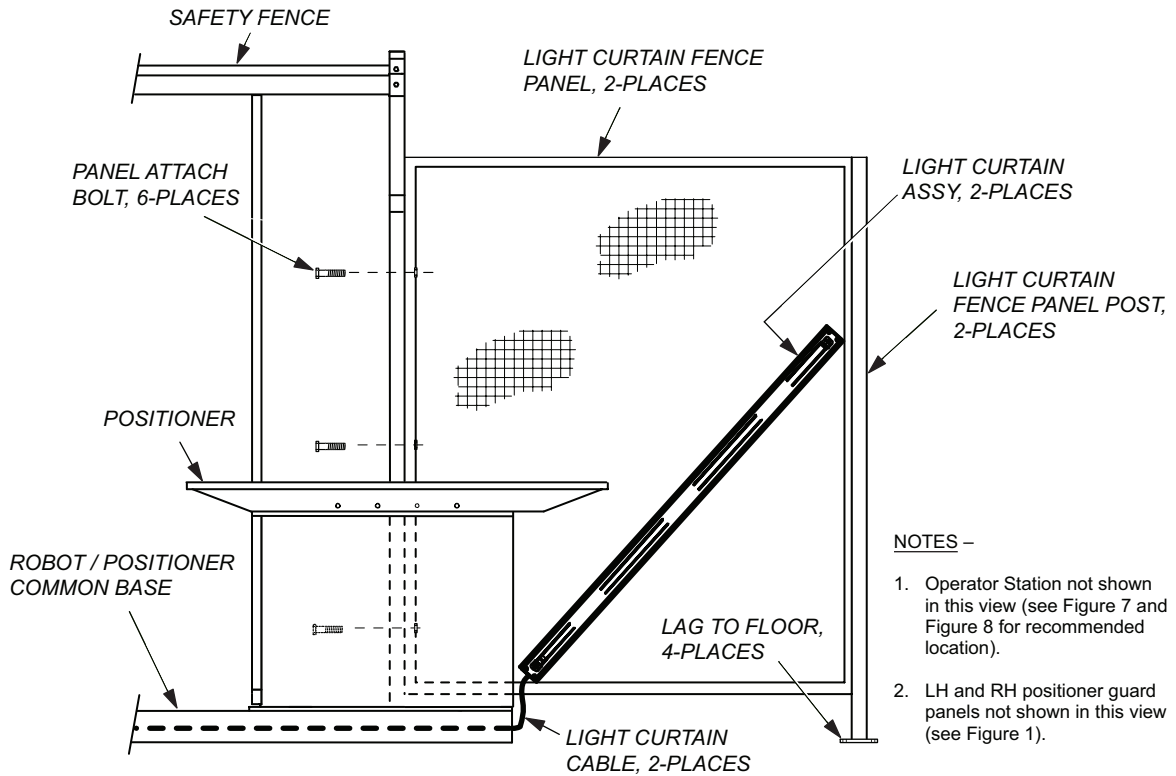

Figure 11 Light Curtain Installation

4.7 Removing the Robot Shipping Bracket



CAUTION!

Be sure to remove the shipping bracket from each EA1400N robot prior to power-up or operation. Operation of a robot, without first removing the shipping bracket, can damage the robot drive components.

A bracket is installed on each robot at the factory to prevent undesired movement during shipping (see Figure 12). The bracket is painted a bright yellow color for easy location and identification. The bracket secures the lower arm (L-axis) of the robot to the S-axis housing. In addition, the bracket provides the correct hoisting points should either of the robots need to be removed from the ArcWorld®-1200 DRC work cell. Upon bracket removal, be sure to keep both brackets and attaching hardware in a safe location, should they be needed in the future.



Note: Refer to special lifting procedures in the EA1400N Manipulator Manual should the robot need to be lifted and moved from the robot/positioner common base. Incorrect lifting technique can damage the robot.



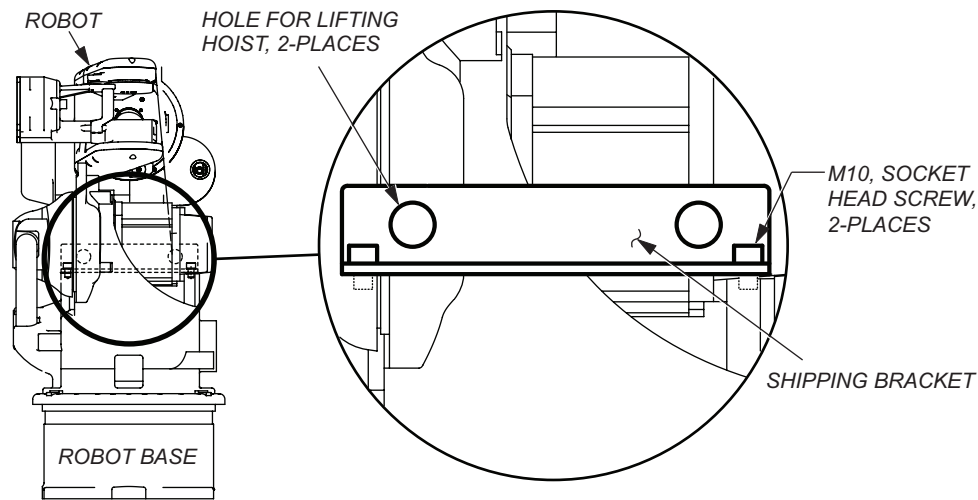

Figure 12 Robot Shipping Bracket

4.8 Cable Connections



CAUTION!

Route cables away from hazardous work areas. It is important to keep cables covered / hidden as much as possible to avoid cable damage and possible interruption of work cell operation.

After the ArcWorld®-1200 DRC components and peripherals are secured in their correct locations, unwrap the cables from around the equipment and route them according to the cable diagrams included in the documentation supplied with your ArcWorld®-1200 DRC system. All cables are labelled to match the labels at the connection points.



Note: A small gap exists between the bottom of the work cell safety fence and the robot/positioner common base. This gap provides a passage for cables that must run between components that are outside the work cell and those that are inside the work cell.

4.8.1 Connection to Earth Ground



WARNING!

Do not use the ArcWorld®-1200 DRC system unless specified components are connected to a low-resistance earth ground. Do not connect the earth ground wire with the wires for the electric power source, welder, etc. The low-resistance earth ground must be a “dedicated” ground that is a direct connection between the component and the earth ground point. Operator injury or death, as well as equipment damage, can result from an inadequate or defective earth ground system.

Each robot and the NX100-DRC must be connected to an earth ground. If a ground stake is used, it should be driven at least 2m into the soil. The soil surrounding the driven ground

stake should be treated with a chemical that increases the soil conductivity in the vicinity of the driven ground stake. This is often referred to as a “low-resistance earth ground” and may require quite a bit more than a single driven ground rod, depending on soil conditions. Often, multiple ground stakes (bonded together) or even a bonded network of buried copper sheeting (plus conduction-enhancing chemicals) may be required, depending on local soil condition. In any event, the “low-resistance earth ground” must indicate a resistance of **100 ohms or less** (when measured directly between grounded equipment and the earth ground system). Be advised that specialized measuring equipment is usually required to get an accurate “resistance-to-ground” reading. Consult a specialist in this field, if required.



Note: The customer must supply all wires associated with the earth ground. The customer is responsible for establishing and maintaining an adequate earth ground (must maintain resistance of 100 ohms or less).

Connect both robots and the NX100-DRC controller to the earth ground as follows:

1. Connect one end of an earth ground wire to the lug marked EARTH GROUND on the connector panel of EA1400N robot (R1). Connect the other end of the earth ground wire to the low-resistance earth ground.
2. Connect one end of an earth ground wire to the lug marked EARTH GROUND on the connector panel of EA1400N robot (R2). Connect the other end of the earth ground wire to the low-resistance earth ground.
3. Connect one end of an earth ground wire to the COMMON GROUND BUS BAR located inside the NX100-DRC controller (R1). Connect the other end of the earth ground wire to the low-resistance earth ground.

4.8.2 Connection to Local Electrical Service



WARNING!

Connection of the ArcWorld[®]-1200 DRC system to local electrical service must be performed by a qualified, licensed electrician. Electrical and grounding connections must comply with the National Electrical Code (NEC) as well as local electrical codes.

After installation and interconnection of ArcWorld[®]-1200 DRC system components, connect local electrical service at the following locations –

- Two disconnect boxes (one for each welding power source). These are located on the NX100-DRC / Welding Power Sources common base (see Figure 1 and Figure 2)
- Power input to the NX100-DRC controller (see Figure 2).



Note: The ArcWorld[®]-1200 DRC is configured for 3-phase 460/480V AC primary power. For additional information, please refer to the electrical drawings and schematics that are included with your ArcWorld[®]-1200 DRC system.



4.9 Safety / Operation Check

Before installing the tooling and fixtures for your application, take a few minutes to perform the following safety/operation check –

1. Ensure that the shipping bracket is removed from each EA1400N robot (refer to Section 4.7).
2. Ensure a clearance of at least 2.5 cm (1 in.) exists on either side of the MR-300 rotary positioner.
3. Ensure correct alignment and operation of the safety light curtain sender and receiver units.
4. Ensure that both work cell access doors are closed and door interlocks engaged.
5. Check the torque and security of all cable connections.
6. Ensure the correct setting of the welding power sources (refer to the welding power source documentation that is included with your ArcWorld®-1200 DRC system).
7. Verify that local electrical service is correctly wired into the NX100-DRC controller (refer to Section 4.8.2).
8. Verify that local electrical service is correctly wired into each welding power source disconnect box (located on NX100-DRC / Welding Power Sources common base (refer to Section 4.8.2).
9. Verify that the local electrical service line voltage and phase comply with the voltage and phase requirements for your ArcWorld®-1200 DRC system.



CAUTION!

The ArcWorld®-1200 DRC system is now ready for power-up. Ensure that qualified, trained operators, who are familiar with the ArcWorld®-1200 DRC system, perform this power-up sequence.

10. Set POWER ON-OFF switch on the NX100-DRC controller (R1) to ON (see Figure 2).
11. Switch ON the electrical service disconnect box for each welding power source. These are located on the NX100-DRC / Welding Power Sources common base (see Figure 2).



WARNING!

Before operating the robots, check each E-Stop push button to verify that servo power can be disabled by activation of the E-Stop. Injury to personnel or equipment damage can result from an E-Stop circuit defect. The E-Stop push buttons must be able to positively stop robot and positioner movement during an emergency situation.

12. Check system E-Stop push buttons
13. Check system HOLD buttons.
14. Ensure correct action of safety interlocks on both work cell access doors.
15. Remove power from the ArcWorld®-1200 DRC system after completion of the safety / operation check.



4.10 Installation of Tooling and Fixtures

Your ArcWorld®-1200 DRC system is now ready for installation of tooling and fixtures for your particular application. Personnel who are familiar with the operation of the ArcWorld®-1200 DRC system should do the installation. After the installation, test the MR-300 positioner for correct operation.



Note: All tooling and fixtures for the MR-300 rotary positioner shall be supplied by the customer.



Everything for your HMI running

✉ sales@vicpas.com

☎ +86-15876525394

Chapter 5

Operation

The ArcWorld®-1200 DRC system is a fully integrated robotic GMAW welding cell. Two Motoman EA1400N robots weld on one side of the MR-300 rotary positioner while the operator loads the opposite side with a part to be welded. When the robots complete a welding cycle, they return to a HOME (Safe) position. The operator then enables the positioner sweep, allowing the robots to start welding on the next part. This section provides operation instructions for the ArcWorld®-1200 DRC system.

5.1 Programming

The operation of this system is programming dependent. The following operating instructions are based on one possible configuration of this system. Your system configuration and job structure may differ slightly from that presented here; however, basic operation will be the same. For additional programming procedures and information, refer to the NX100-DRC controller documentation that is included with your ArcWorld®-1200 DRC system (refer to Section 1.3).

Any changes made to your system configuration and/or job structure will alter the operation of the system. Motoman recommends that you **DO NOT** modify the original jobs and system configuration of your ArcWorld®-1200 DRC system. If you do modify the original jobs and system configuration, make those modifications to a copy of the original. Keep the original as a backup. Do not modify the original. Modifications must be performed by trained and experienced personnel, who are familiar with the operation of the ArcWorld®-1200 DRC system. If you have questions concerning the configuration of your ArcWorld®-1200 DRC system, please contact Motoman 24 hour Customer Support (refer to Section 1.4).

5.2 Sweeping the Positioner



Note: Ensure that both robots are in the HOME (Safe) position before sweeping the positioner.

MANUAL mode allows you to sweep the MR-300 positioner without activating the robots. Parts can be loaded onto the fixture to achieve the most efficient configuration and then swept into the welding

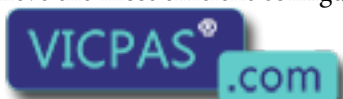

zone, before teaching the robots a series of moves. To sweep Side A or Side B of the positioner into the robot's welding zone, proceed as follows –

1. Move both robots to HOME position (refer to Section 5.3.2).
2. Make sure that the Operator Station is enabled (Programming Pendant MODE SELECT SWITCH set to REMOTE).
3. Set the Operator Station POSITIONER switch to MANUAL mode and start Master Control job (see Section 5.3.3). Normally, robots will not move out of HOME position when the POSITIONER switch is in MANUAL. (This depends on job structure.)



Note: Cycle Start latching is not operational in MANUAL mode.

4. Press the CYCLE START button on Operator Station (the MR-300 positioner sweeps each time the CYCLE START button is pressed).

5.3 Daily Operation

The procedures below represent the typical operating sequence from power up to shutdown. Your basic operating procedures may vary depending on your situation.

- Perform start-up procedures (refer to Section 5.3.1).
- Move robots to HOME position (refer to Section 5.3.2).
- Select master job (refer to Section 5.3.3).
- Perform operation cycle (refer to Section 5.3.4)
- Perform standard shutdown procedures (refer to Section 5.3.5)

5.3.1 Start-Up

Procedure –

1. Set POWER ON-OFF switch on NX100-DRC controller (R1) to ON (see Figure 2).
2. Switch both welding power source electrical service disconnect boxes to ON (see Figure 2).
3. Set POWER ON-OFF switch on each welding power source to ON (ON-OFF indicator lamp on each welding power source will illuminate).
4. Open regulator valve on welding gas supply.
5. Make sure that both work cell doors are closed and door safety interlocks engaged.
6. Make sure all E-Stop buttons are released. E-Stop buttons are installed at the following locations:
 - Programming pendant
 - Door of the NX100-DRC controller (R1)
 - Operator Station pedestal
7. Select TEACH mode on the Programming Pendant.
8. Move robots to HOME position (refer to Section 5.3.2).

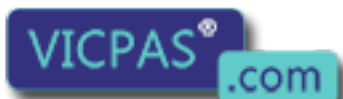

5.3.2 Move Robots to HOME Position

Procedure –

1. Select TEACH mode on the Programming Pendant.
2. Select MAIN MENU on Programming Pendant touch screen.
3. Select JOB on Programming Pendant touch screen.
4. Select SELECT JOB on Programming Pendant touch screen (a job list appears on the screen).
5. Use the navigation cursor key to move the cursor to R1 SAFE job and press SELECT (the job appears on the display screen).
6. Turn servo power ON by pressing SERVO ON and holding in the ENABLE switch.
7. Use the FWD button on Programming Pendant to jog robot (R1) to HOME position.
8. Use the navigation cursor key to move the cursor to R2 SAFE job and press SELECT (the job appears on the display screen).
9. Turn servo power ON by pressing SERVO ON and holding in the ENABLE switch.
10. Use the FWD button on Programming Pendant to jog robot (R2) to HOME position.

5.3.3 Select Master Job

Procedure –

1. Select JOB on Programming Pendant touch screen.
2. Select CTRL MASTER on Programming Pendant touch screen. Press SELECT twice to activate the Master job.
3. Select PLAY mode on Programming Pendant and press the PLAY ENABLE button on the NX100-DRC controller (R1) door (job playback operation is enabled).
4. Press SERVO ON button on the Programming Pendant.
5. Press START button on Programming Pendant (the Master job cycles, waiting for a CYCLE START input from Operator Station).
6. Transfer control to the Operator Station by selecting REMOTE on the Programming Pendant MODE SELECT SWITCH.

The ArcWorld®-1200 DRC work cell is now ready for operation.

5.3.4 Operation Cycle

The following is the typical sequence of operation for the ArcWorld[®]-1200 DRC work cell after start-up –

1. Operator loads the fixture (on operator side of positioner) with part to be welded.
2. Operator steps out of safety zone created by the safety light curtain system, and moves to front of Operator Station pedestal.
3. Operator presses the green CYCLE START button on Operator Station pedestal. The MR-300 positioner sweeps 180°, thus placing part to be welded into the robot work area. The robots then begin to weld the part (if the Operator Station POSITIONER AUTO/MANUAL switch is set to AUTO).
4. While the robots are welding, the operator loads operator side of the positioner with the next part to be welded.
5. The operator again moves to the Operator Station pedestal and presses the green CYCLE START button (CYCLE LATCHED light illuminates). When the robots are finished welding, they return to HOME position. The MR-300 positioner then sweeps 180° to return the completed, welded part to the operator position, while moving the next part into the robot work area.
6. Operator moves back to the operator side of the MR-300 positioner and unloads completed, welded part.

5.3.5 Standard Shutdown

Procedure –

1. Verify that both robots are in the HOME position.
2. Turn off system servo power by pressing the E-Stop button on Operator Station pedestal or Programming Pendant.
3. Select TEACH mode on the Programming Pendant.
4. Set NX100-DRC controller (R1) POWER ON-OFF switch to OFF position.
5. Set both welding power source POWER ON-OFF switches to OFF position.
6. Close regulator valve on welding gas supply.
7. Switch all electrical service disconnect boxes to OFF

The ArcWorld[®]-1200 DRC system is now shut down.

5.4 System Recovery

When a system error or alarm occurs, you must clear the error or alarm to return the system to normal operation. The paragraphs below describe the different types of alarms and errors you may encounter, and how to clear them.



5.4.1 Alarms and Errors

Alarms and errors will stop the program. There are three levels:

- Error Messages
- Minor Alarms
- Major Alarms.

For more detailed information on alarm and error recovery, refer to the NX100-DRC controller and EA1400N robot documentation that is included with your ArcWorld®-1200 DRC system (refer to Section 1.3).

5.4.1.1 Error Messages

Error messages are usually the result of simple, easily-cleared operation errors. An example could include:

- Pressing the START button when the robots are not in PLAY mode

Clear errors of this type by pressing the CANCEL button on the Programming Pendant.

5.4.1.2 Minor Alarms

Minor alarms usually involve programming errors. Clear alarms of this type by pressing the CANCEL button on the Programming Pendant.

5.4.1.3 Major Alarms

Major alarms usually involve hardware failures. Examples could include:

- An overload condition
- An abnormal speed

Clear alarms of this type by cycling the NX100-DRC controller (R1). Cycling involves setting the POWER ON-OFF switch to OFF for 5 to 8 seconds, then back to ON.



5.4.2 E-Stop Recovery

An E-Stop (emergency stop) will occur under any of the following conditions –

- An E-Stop switch is pushed in (activated)
- Either work cell access door is opened while the robots are not in TEACH mode
- The safety light curtain system is triggered while the positioner is sweeping
- A collision triggers a shock sensor output

After an E-Stop condition, restart the ArcWorld®-1200 DRC system as follows –

1. To clear the E-Stop condition, perform any of the following actions that apply –
 - Release the activated E-Stop push button
 - Close work cell access door(s)
 - Clear the area in front of the positioner that is protected by the safety light curtain system
 - Clear shock sensor condition (refer to Section 5.4.3).



CAUTION!

If an E-Stop condition occurs while the positioner is sweeping, the positioner will continue the sweep when the ArcWorld®-1200 DRC system is restarted.

2. Press the SERVO ON button on the Programming Pendant.
3. Select REMOTE mode on the Programming Pendant MODE SELECT SWITCH to transfer control of the system to the Operator Station.
4. Press the green CYCLE START/CYCLE LATCHED push button on the Operator Station.

The ArcWorld®-1200 DRC system is now ready to continue operation.

5.4.3 Shock Sensor Recovery

Each EA1400N robot includes a Motoman gun mount. This mount is designed to protect the torch from damage in case of a crash. A slight deflection of the torch activates a SHOCK SENSOR signal that triggers an E-Stop condition. To clear the E-Stop condition, you must override the shock sensor and move the affected robot clear of the impact. To override the shock sensor, proceed as follows:

1. Select MAIN MENU on Programming Pendant touch screen.
2. Select ROBOT on Programming Pendant touch screen.
3. Select OVERRUN-S.SENSOR on Programming Pendant touch screen.
4. Select RELEASE to release shock sensor.
5. Turn servo power ON (press in on the pendant ENABLE switch while pressing SERVO ON READY).
6. Move the affected robot clear of the impact position.

The ArcWorld®-1200 DRC system is now ready to continue operation.

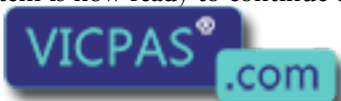

5.4.4 Brake Release

The robot braking system is designed to protect the robots and other system components from damage in the event of a system/robot failure or loss of drive power. If a system or robot failure occurs, you must release the brakes on the affected robot in order to move it.

Procedure –



WARNING!

Always support the robot axis to be released BEFORE you release it. Without adequate robot axis support, brake release could cause personal injury or machine damage.

1. On the Programming Pendant, select TEACH mode and turn servo power OFF.
2. Select ROBOT on the Programming Pendant touch screen display.
3. Select the BRAKE RELEASE option.
4. Use the CURSOR key to select desired robot axis for release.
5. While pressing in on the pendant ENABLE switch, hold down the INTERLOCK key plus the SELECT key.
6. The brake for the selected axis will release.



NOTES



Everything for your HMI running
✉ sales@vicpas.com
☎ +86-15876525394

MOTOMAN
a YASKAWA company

Chapter 6

Maintenance

Maintenance of the ArcWorld®-1200 DRC system and components must be performed by authorized personnel who are familiar with the ArcWorld®-1200 DRC system. Perform the procedures given in this chapter only as needed (on condition). Be sure to read and understand the documentation for a particular component before doing repair maintenance or preventive maintenance on that component. Be sure that you understand the maintenance procedures, have the proper tools at hand, and comply with safety precautions given in Chapter 2.

Be advised that the maintenance intervals given in this chapter are recommendations, only. Adjust the frequency and level of repair maintenance and preventive maintenance to suit your specific equipment schedules and shop environment.

For periodic maintenance procedures and schedules for the individual components of your ArcWorld®-1200 DRC system, refer to the documentation that is included with your ArcWorld®-1200 DRC system (refer to Section 1.3).



CAUTION!

If your system uses water-cooled torches, use only Motoman-specified antifreeze in the water circulators. Typical automotive antifreeze contains additives that can clog the small cooling ports in the torches, and can damage sealing gaskets in the water circulator pumps.

Table 1 Periodic Maintenance

FREQUENCY	COMPONENT	PROCEDURE
Daily (or on condition)	Water Circulators (water-cooled torch application, only)	Add a mixture of Motoman antifreeze (P/N 131224-1) and distilled water, as required. Mix antifreeze and distilled water in proportions shown on the anti-freeze container.
	All safeguard items – work cell door interlocks, E-Stop push buttons, safety light curtains, arc curtains, etc.	Check physical condition of safeguard item and ensure that the safeguard item is working correctly
Monthly (or on condition)	ArcWorld®-1200 DRC work cell	Remove accumulated dirt, grease, and debris from inside and outside the work cell.



NOTES



Everything for your HMI running
✉ sales@vicpas.com
☎ +86-15876525394

MOTOMAN
a YASKAWA company

Appendix A

Anchoring

The customer must determine all anchoring and foundation requirements, and supply the appropriate anchoring hardware and foundation for a particular system installation. Table A.1 gives anchoring and foundation suggestions.

Table A.1 Suggested Anchor, Floor Plate, and Foundation Specifications

SYSTEM EQUIPMENT	MINIMUM HILTI® ANCHOR ROD DIAMETER AND TYPE	MINIMUM FLOOR PLATE	MINIMUM FOUNDATION
ROBOTS UP6, UP20 UP20-6 EA1400N EA1900N	5/8" HVA Chemical Anchor (Note 3) (Note 5) (Note 6)	600 mm (24 in) Length 600 mm (24 in) Width 38.1 mm (1.5 in) Thick	762 mm (30 in) Length 762 mm (30 in) Width 178 mm (7 in) Thick 4000 psi Reinforced Concrete
ROBOTS UP20M, UP50 SP80 (Note 2)	7/8" HVA Chemical Anchor (Note 3) (Note 5) (Note 6)	900 mm (35 in) Length 900 mm (35 in) Width 50.8 mm (2 in) Thick	1524 mm (60 in) Length 1524 mm (60 in) Width 229 mm (9 in) Thick 4000 psi Reinforced Concrete
ROBOTS UP120,UP130 UP165,SP100 SP160,SP250 SP400 (Note 2)	7/8" HVA Chemical Anchor (Note 3) (Note 5) (Note 6)	1200 mm (47 in) Length 1200 mm (47 in) Width 50.8 mm (2 in) Thick	1828 mm (72 in) Length 1828 mm (72 in) Width 229 mm (9 in) Thick 4000 psi Reinforced Concrete
ROBOTS UP200	7/8" HVA Chemical Anchor (Note 3) (Note 5) (Note 6)	1200 mm (47 in) Length 1200 mm (47 in) Width 50.8 mm (2 in) Thick	1828 mm (72 in) Length 1828 mm (72 in) Width 229 mm (9 in) Thick 4000 psi Reinforced Concrete
ROBOTS UP350, UP500, SK300X	7/8" HVA Chemical Anchor (Note 3) (Note 5) (Note 6)	1500 mm (59 in) Length 1500 mm (59 in) Width 50.8 mm (2 in) Thick	1828 mm (72 in) Length 1828 mm (72 in) Width 229 mm (9 in) Thick 4000 psi Reinforced Concrete



Table A.1 Suggested Anchor, Floor Plate, and Foundation Specifications

SYSTEM EQUIPMENT	MINIMUM HILTI® ANCHOR ROD DIAMETER AND TYPE	MINIMUM FLOOR PLATE	MINIMUM FOUNDATION
<u>POSITIONER</u> Table type (360° rotary or 180° recip.)	5/8" HVA Chemical Anchor (Note 3) (Note 6)	Not Applicable	Refer to Applicable Positioner Manual
<u>POSITIONER</u> Ferris wheel type (HS/TS)	7/8" HVA Chemical Anchor (Note 3) (Note 6)	Not Applicable	Refer to Applicable Positioner Manual
<u>PERIPHERAL EQUIPMENT</u>	1/2" Kwik Bolt II Expansion Anchor (Note 4) (Note 6)	Not Applicable	3" min thickness or 1.3 Embedment Depth (whichever is larger), 4000 psi Reinforced Concrete
<u>WORK CELL FENCE POSTS</u>	3/8" Kwik Bolt II Expansion Anchor (Note 4) (Note 6)	Not Applicable	3" min thickness or 1.3 Embedment Depth (whichever is larger), 4000 psi Reinforced Concrete
<p><u>NOTES</u> –</p> <p>(1) Minimum robot lagging requirements are based on <u>maximum repulsion forces</u> and <i>Hilti® Anchor Design Program</i> (v3.3b).</p> <p>(2) SP series robots require base plates and/or risers to be level to $\pm 2^\circ$. Grout if necessary.</p> <p>(3) Reference source: <i>Hilti® Product Technical Guide</i> (section 4.2.1) for hardware specifications or equivalent.</p> <p>(4) Reference source: <i>Hilti® Product Technical Guide</i> (section 4.3.3) for hardware specifications or equivalent.</p> <p>(5) Cast-in anchors are specified in some robot manuals. The Hilti® HVA Chemical Anchors listed in this table can be substituted for the cast-in anchors.</p> <p>(6) Refer to <i>Hilti® Product Technical Guide</i> for suggestions on the correct size and type of <u>drill bit</u> to use with each anchor type.</p> <p> Contact Information –</p> <p>1-800-879-8000 (USA) http://us.hilti.com</p> <p>1-800-363-4458 (CAN) http://ca.hilti.com</p>			



Index

A

about this document, 1
alarms and errors, 35
anchoring suggestions, 41
ANSI / RIA, 5, 7
antifreeze (for optional water circulators), 39
ArcWorld®-1200 DRC
 common equipment bases, 3
 layout, 3
 major components, 3
 optional equipment, 3
 operation, 31
 overview, 2
 preventive maintenance, 39
 reference documentation, 4

B

back-ups (*see* programming, back-up)
brake release (*see* system, brake release)

C

cable connections
 cautions, 27
 earth ground requirement (*see* earth ground)
 and routing, 27
 to local electrical service, 28
controller (*see* NX100-DRC controller)
customer support (how to contact), 4

D

daily operation (*see* operation, daily)
documentation (*see* ArcWorld®-1200 DRC,
 reference documentation).
doors (work cell access), 17

E

earth ground
 description, 27– 28
 procedure, 28
 warning about importance of, 27

E (cont.)

E-Stop
 activation of, 16
 description, 16
 location of push buttons, 16
 recovery from, 17, 36

H

HOME position (robots), 33

I

installation
 operator station, 24
 and leveling robot / positioner common base, 21
 and leveling the NX100-DRC / weld power
 source common base, 23
 required materials, 19
 customer-supplied items, 19
 recommended hand tools and equip, 20
 and qualified personnel, 19
 safety (*see* safety overview, installation)
 safety light curtains, 25
 safety light curtain fence panels, 25
 tooling and fixtures, 30
introduction, 1

L

low-resistance earth ground (*see* earth ground)

M

maintenance, 39
MASTER job (*see* operation, daily)
MR-300 positioner (*see* positioner)

N

NX100-DRC controller
 description, 9
 DRC configuration, 9
 and expansion cabinet, 9
 operating system, 10
 and programming pendant, 10

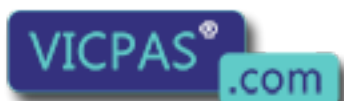

O

- operation
 - programming, 31
 - sweeping the positioner, 31
 - daily, 32
- operator station
 - controls, 12
 - functions, 12 – 13
 - installation, 24
- optional equipment list, 3

P

- passwords
 - special, 8
 - standard, 8
- positioner
 - arc screen, 14
 - corrosion prevention, 14
 - description, 14
 - fixtures (customer supplied), 14
 - type, 14
- programming
 - back-up, 31
 - language, 10
 - pendant, 10-11
 - technique, 31
- preventive maintenance (*see* maintenance)

R

- recommended hand tools and equipment, 20
- replacement parts (*see* customer support)
- robot
 - hard stops (S-axis), 2
 - HOME position, 33
 - payload, 9
 - positioning accuracy, 9
 - reach, 9
 - shipping bracket, 26
 - type, 9
- Robotic Industries Association (RIA), 5

S

- safeguarding
 - responsibility for, 15
 - tips, 6
 - safety
 - arc protection, 16
 - E-Stop, 16 – 17
 - emergency braking system, 17
 - enable switch (programming pendant), 17
 - equipment, 3
 - features, 15 – 17
 - fencing, 16
 - light curtains, 16
 - safety / operation check, 29
 - work cell door interlocks, 17
 - safety overview
 - introduction, 5
 - standard conventions, 6
 - installation, 7
 - programming, operation, and maintenance, 7
 - shock sensor
 - description, 36
 - recovery, 36
 - site preparation (prior to installation), 20
 - system
 - alarms and errors, 35
 - brake release, 37
 - equipment description, 9
 - E-Stop recovery, 36
 - layout, 3
 - overview, 2
 - shock sense recovery, 36
 - shutdown, 34
 - start-up, 32
- ## W
- water circulators (optional), 3, 39
 - welding equipment
 - GMAW torch, 15
 - power sources, 15
 - supplied with your system, 15
 - wire feeder, 15
 - Windows® CE operating system, 10

