

eTOP-MON1500T Tech-Note

15" 4:3 LCD display eTOP-MON1500T is based on a 5-wire resistive touch screen. It has 400 nits brightness and can support resolutions up to 1024 x 768. eTOP-MON1500T is ideal for space-critical environments where systems and displays are kept apart. In addition, eTOP-MON1500T adopts a flush panel design and has IP65 front panel. eTOP-MON1500T provides prevailing video interfaces: VGA and DVI, supporting both digital and analog signals; touch screen can be connected with RS-232 or USB ports. Moreover, eTOP-MON1500T supports 12~24VDC power input and offers panel mount and VESA mount, allowing users to choose the mounting method that meets their situation. eTOP-MON1500T is the best solution for eCC fanless computer and EPC panel PC when a second display is required.



- IP65 compliant plastic front bezel with flush panel by 5-wire touchscreen
- Dual display input interface: analog VGA and DVI-D
- Shares identical appearance with EPC series
- Dual touch screen interface: RS232 and USB
- Ultra slim in depth
- OSD multilanguage function

Specifications

Panel

- LCD size: 15", 4:3
- Resolution: XGA 1024 x 768
- Luminance: 450cd/m2
- Contrast ratio: 800
- LCD color: 16.2M
- Viewing angle: 70 (U), 80 (D), 80 (L), 80 (R)
- Backlight: LED

Touch Screen

- 5-wire resistive (flush panel type)
- Light transmission: 81%
- Interface: USB and RS232

Rear I/O

- Touch screen interface port: RS-232 (1 x DB9)/USB type A
- Video port: VGA (1 x DB15)/DVI-D (1 x DVI-I connector)
- DC power input connector: 3-pin Phoenix terminal blocks

OSD Function

- OSD keypad
- Multilanguage OSD

Mechanical & Environment

- Color: Pantone black
- IP protection: IP65 front
- Mounting: panel/wall/stand/VESA 100mm x 100mm
- Power input: 12V~24VDC
- Power adapter: optional AC to DC power adapter (+12V, 60W)
- Vibration: IEC 68 2-64 2Grms @ sine, 5~500Hz, 1hr/axis (operating) 2.2Grms @ random condition, 5~500Hz, 0.5hr/axis (non-operating)
- Shock: IEC 68 2-27 20G@wall mount, half sine, 11ms Operating temperature: -5°C to 50°C Storage temperature: -20°C to 75°C
- Operating humidity: 10%~90% relative humidity, non-condensing
- Dimension: 384.37 x 309.95 x 51.2mm
- Weight: 3.98Kg



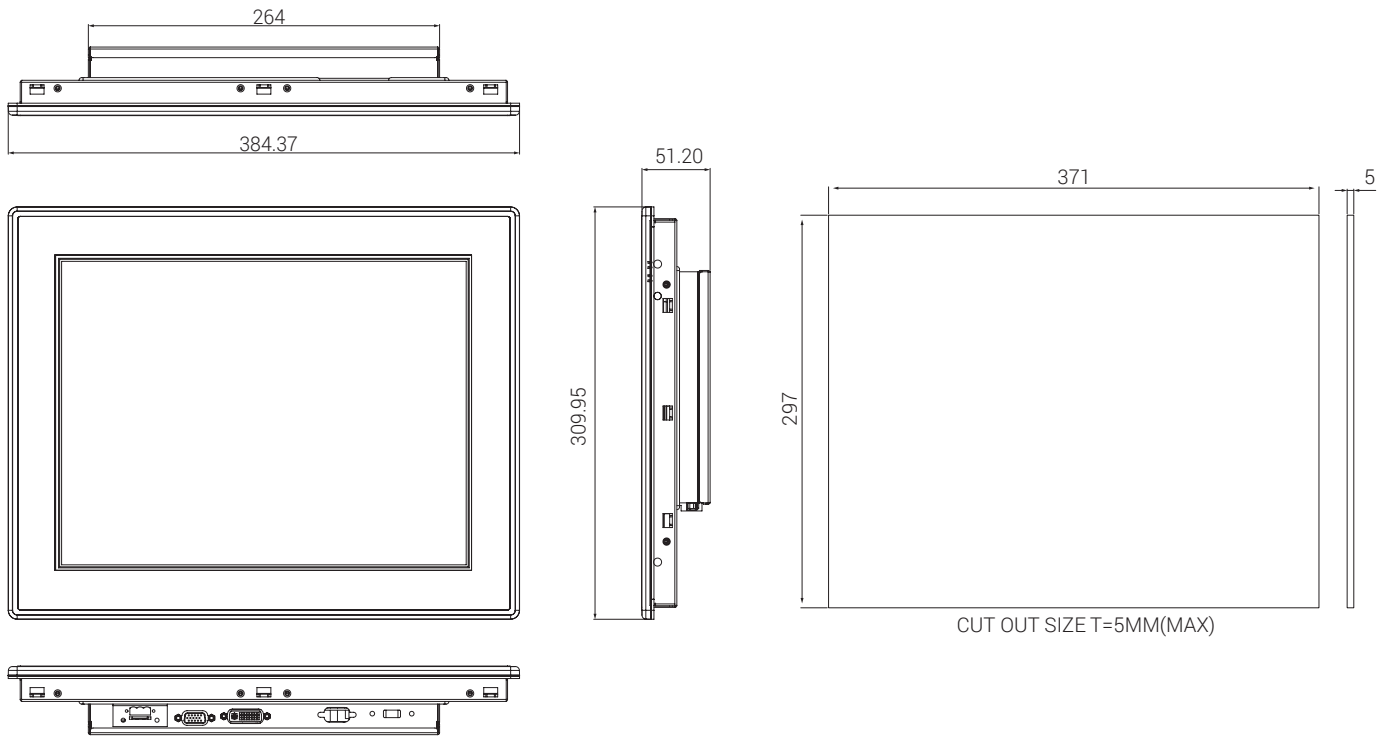

Ordering Information

Model	Part Number	Description
eTOP-MON1500T	+73MON1500T	15" VGA Industrial 4.3 LED Backlight Fish touch monitor



Everything for your fish farming

✉ sales@vicpas.com

📞 +86-15876525394