

eTOP-EPC1230T/1231T



Main Features

- 4:3 12.1" SVGA Fanless LED Panel Computer
- Intel® Atom™ D2550, Dual Core, Low Consumption CPU
- Flush Panel by 5-wire Touch Screen
- Dual GbE/ 2nd display-VGA/ Line-in/ Line-out/ MIC-in/ PS2 KB/MS
- USB x4/ 2x Mini-PCIe sockets/ 1x CFast/ 2x RS232/ 422/ 485
- Optional 3.5G/ Wi-Fi Module / 2.5" HDD/ 2x COMs / GPIO / DIO
- DDR3 2GB/ 2.5" HDD Bracket
- IP65 Compliant Front Panel
- Mounting Support: Panel/ Wall/ Stand/ VESA 100mm x 100mm
- Wide Range Power Input 12V~30V DC

Product Overview

The 12.1" fanless panel PC eTOP-EPC230T/1231T incorporating an industrial motherboard is intended for versatile industrial applications. eTOP-EPC1230T/1231T has a touch screen LED backlight LCD panel with 800x600 (SVGA) resolution and 450-nit brightness. The front panel which adopts flush design and complies with IP65 standard makes it the perfect fit in industrial applications.

This APCC series supports WWAN/WLAN expansion and others via dual Gigabit Ethernet connectors, two Mini-PCIe slots and one SIM card holder. With support for wide power input of 12V~30V, this eTOP-EPC series can gain a strong foothold in industrial field and machine devices. In addition, this eTOP-EPC series can hook 2nd display via a VGA port for dual independent display. eTOP-EPC1231T has two isolated RS232/422/485 ports, two RS232 ports supporting 5V and 12V power feed, four isolated channels of DI and DO, and two channels of GPI and GPO.

Specifications

Panel

- LED Size: 12.1", 4:3
- Resolution: SVGA 800x600
- Luminance: 450cd/m²
- Contrast ratio: 700
- LCD color: 16.2M
- Viewing Angle: 65(U), 75(D), 80(L), 80(R)
- Backlight: LED

Touch Screen

- 5-wire resistive (flush panel type)
- Light transmission: 80%
- Interface: USB

System

- CPU: On-board Intel® Atom™ Dual Core processor D2550, 1.86GHz, 1M L2 Cache
- BIOS: AMI BIOS
- System chipset: Intel® NM10 Express chipset
- System memory: 2x 204-pin DDR3 SO-DIMM socket (Default), Support up to 4GB DDR3-800/1066, Non-buffered
- Storage Device:

- 1x external locked CFast socket
- 1x hard drive bay: optional 1x 2.5" SATA HDD or 1x SATA DOM
- Watchdog timer: Watchdog timeout can be programmable by software from 1 second to 255 seconds and from 1 minute to 255 minutes (Tolerance 15% under room temperature 25°C)
- H/W status monitor: Monitoring system temperature, and voltage
- Expansion: 2x Mini-PCIe sockets (support optional Wi-Fi or 3.5G module)
- Panel backlight control button: Increase brightness / decrease brightness / Backlight On/Off (For eTOP-EPC1231T only)

Rear I/O

- Ethernet: 2x RJ45
- 2nd display VGA port: 1x DB15
- Audio port: 1x Line out; 1x Line in; 1x MIC-in
- USB: 4x USB 2.0
- PS2 keyboard/ mouse
- Power switch / Reset button
- COM #1: RS232/422/485 w/RI or 5V selection
- COM #2: RS232/422/485 w/RI or 12V selection
- DI/DO: 4x isolated
- GPI/GPO: 2x isolated



Everything for your HMI running

sales@vicpas.com
+86-15876525394



Dimension Drawing

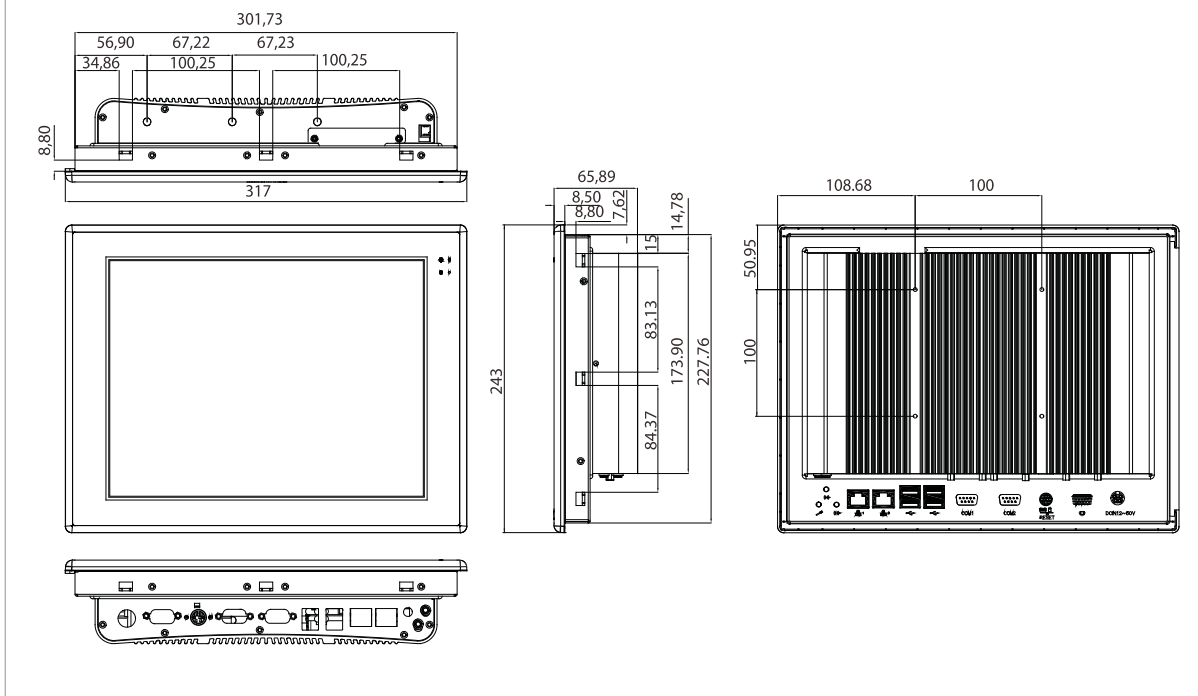

- 4x Digital Input (Source type)
 - Input Voltage (Dry Contact): Logic 0: Close to GND
 - Logic 1: Open
 - Input Voltage: Logic 0: 3V max
 - Logic 1: +5V ~ +30V
- 4x Digital Output (Sink type)
 - Output Voltage: 3.6V ~ 5V
 - Sink current: 200 mA max. per channel
- GPIO: 2x digital in / 2x digital out
- COM #1: RS232/422/485 w/ 2.5kv isolated
- COM #2: RS232/422/485 w/ 2.5kv isolated
- COM #3: RS232 w/ RI or 5V selection
- COM #4: RS232 w/ RI or 12V selection
- Vibration:
 - IEC 68 2-64 (w/ HDD)
 - 1Grms @ sine, 5~500Hz, 1hr/axis (HDD Operating)
 - 2Grms @ sine, 5~500Hz, 1hr/axis (CFast Operating)
 - 2.2Grms @ random condition, 5~500Hz, 0.5hr/axis (Non-operating)
- Shock:
 - IEC 68 2-27
 - HDD: 20G@wall mount, half sine, 11ms
- Operating temperature: -5°C to 60°C
- Storage temperature: -20°C to 75°C
- Operating humidity: 10%~90% relative humidity, non-condensing
 - Limits to be at 90% RH at max 50°C
- Dimension: 317 x 243 x 65.89mm (Cutout: 304.5 x 230mm)
- Weight: 3.9 Kg

Audio

- AC97 codec: Realtek ALC886-GR
- Audio interface: Line out/Line in/MIC-in Audio Jack

Ethernet

- LAN chip: dual Intel® 82574L Gigabit LAN
- Ethernet interface: 10/100/1000 Based-Tx Ethernet compatible

Mechanical & Environment

- Color: pantone blackRAL 15 00 front bezel w/ Pantone 400C\RAL 090 80 10 metal style membrane
- IP protection: IP65 front
- Mounting: panel/ wall/ stand/ VESA 100mm x 100mm
- Power input: 12V~ 30VDC
- Power adapter: Optional AC to DC power adaptor (+12V, 60W)

Certifications

- CE approval

Ordering Information

- eTOP-EPC1230T (P/N: 71EPC1230T)**
12.1" SVGA LED Backlight Touch Panel PC, Intel® Atom™ D2550 1.86 GHz, touch screen, 1GB DDR3, 2x RS232/422/485
- eTOP-EPC1231T (P/N: 71EPC1231T)**
12.1" SVGA LED Backlight Touch Panel PC, Intel® Atom™ D2550 1.86 GHz, touch screen, 1GB DDR3, 2x RS232/422/485 and 4x4 DI/O with isolated protection, 2x RS232, 2x2 GPIO, Brightness adjustment buttons

Copyright 2014 Exor International S.p.A. – Verona, Italy
Subject to change without notice

The information contained in this document is provided for informational purposes only. While efforts were made to verify the accuracy of the information contained in this documentation, it is provided as is. For more information, please contact us at www.exorint.net



Everything for your HMI running

sales@vicpas.com
+86-15876525394

