



Hydraulic Torque Wrench and Tools

HYDRAULIC TORQUE WRENCH AND TOOLS

LOW Series

Product Description

- Low series is the professional hydraulic torque wrench which vigorously extends in international market. Compare with the square drive hydraulic torque wrench, this series work directly on the nuts and its body suits well in the narrow space. Low series covers the nuts from M19-M175 to fulfill all different working situations. The user can just replace the hexagon cassette or add the reducer.



Specifications

- 700 bar maximum working pressure, Repeat Accuracy $\pm 3\%$
- 5 different model from 232~44593 N.m
- $360^\circ \times 185^\circ$ swivel & $360^\circ \times 360^\circ$ swivel allow the wrench easy to operation and with no space limitation.
- More accuracy and easier operate on the nuts.
- Compact design with longer arm fully advances the reliability.
- High resistance with Aluminum-Titanium Alloy and light body.

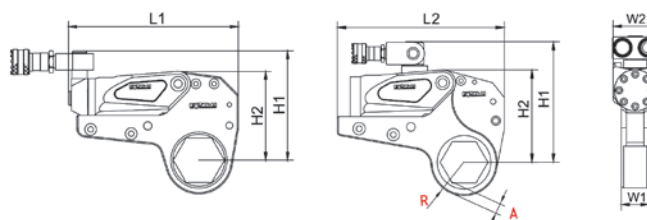

Optional

Reaction Pad	
Extending Reaction Arm	

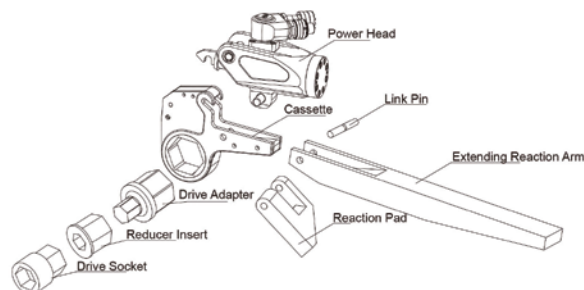

Ordering Information

Model No.	Torque (N. m)	Nut size(mm)	Power head N.W (kg)	Work head N.W (kg)	L1(mm)	L2(mm)	H1(mm)	H2(mm)	W1 (mm)	W2 (mm)
2LOW	232-2328	19-55	1	1.6	196.4	196.4	125.9	102.3	32	51
	241-2414	60	1	1.7	196.4	196.4	128.5	105	32	51
4LOW	585-2510	34-36	2	4.4	245	246	177	135.7	42	66
	585-5021	41	2	4.4	245	246	177	135.7	42	66
	585-5858	46-65	2	4.6	245	246	187	145.7	42	66
	647-6474	70-80	2	4.6	245	246	187	145.7	42	66
8LOW	1049-10491	41-95	3.3	8	300	301	207	169	53	83
	1177-11774	100-105	3.3	8.4	300	301	216	178	53	83
14LOW	1852-18521	50-117	5.5	11.6	361	361	239	204	64	99
30LOW	4188-41882	110-155	11.4	29	430	441	303	272	85	131
	4459-44593	160-175	11.4	30	430	441	315	285	85	131

HYDRAULIC TORQUE WRENCH AND TOOLS

Series Hexagon Cassette Selection Chart

2LOW				4LOW				8LOW			
Type	R(mm)	A(mm)	Max Torque (N.m)	Type	R(mm)	A(mm)	Max Torque (N.m)	Type	R(mm)	A(mm)	Max Torque (N.m)
2LOW-19	27	16	2328	4LOW-34	36	16	2510	8LOW-41	46	22	10941
2LOW-22	27	14	2328	4LOW-36	36	15	2510	8LOW-46	46	19	10941
2LOW-27	27	11	2328	4LOW-41	39	15	5021	8LOW-50	46	17	10941
2LOW-30	29	12	2328	4LOW-46	42	15	5858	8LOW-55	50	18	10941
2LOW-32	29	11	2328	4LOW-50	44	15	5858	8LOW-60	52	17	10941
2LOW-34	31	11	2328	4LOW-55	46	14	5858	8LOW-65	55	17	10941
2LOW-36	31	10	2328	4LOW-60	50	15	5858	8LOW-70	58	17	10941
2LOW-41	34	10	2328	4LOW-65	53	15	5858	8LOW-75	60	17	10941
2LOW-46	37	10	2328	4LOW-70	56	15	6474	8LOW-80	63	16	10941
2LOW-50	40	11	2328	4LOW-75	59	15	6474	8LOW-85	66	16	10941
2LOW-55	43	11	2328	4LOW-80	61	15	6474	8LOW-90	69	17	10941
2LOW-60	46	11	2414					8LOW-95	71	16	10941
								8LOW-100	75	17	11774
								8LOW-105	78	17	11774

14LOW				30LOW			
Type	R(mm)	A(mm)	Max Torque(N.m)	Type	R(mm)	A(mm)	Max Torque(N.m)
14LOW-50	60	31	18521	30LOW-85	78	28	41882
14LOW-55	60	28	18521	30LOW-90	78	27	41882
14LOW-60	60	25	18521	30LOW-95	83	28	41882
14LOW-65	60	22	18521	30LOW-100	83	25	41882
14LOW-70	60	19	18521	30LOW-105	89	28	41882
14LOW-75	63	19	18521	30LOW-110	89	25	41882
14LOW-80	66	19	18521	30LOW-115	95	28	41882
14LOW-85	69	19	18521	30LOW-117	95	27	41882
14LOW-90	72	20	18521	30LOW-120	95	25	41882
14LOW-95	74	19	18521	30LOW-125	101	29	41882
14LOW-100	77	19	18521	30LOW-130	101	26	41882
14LOW-105	80	19	18521	30LOW-135	104	26	41882
14LOW-110	83	19	18521	30LOW-140	110	29	41882
14LOW-115	87	20	18521	30LOW-145	110	26	41882
14LOW-117	87	19	18521	30LOW-150	116	29	41882
				30LOW-155	116	26	41882
				30LOW-160	128	36	44593
				30LOW-165	128	33	44593
				30LOW-170	128	30	44593
				30LOW-175	128	27	44593

HYDRAULIC TORQUE WRENCH AND TOOLS

H Series

Product Description

- H series is the professional hydraulic torque wrench which vigorously extends in international market. H low profile torque wrenches designed for accessing limited areas and serves good solutions with numbers of replaceable cassettes and adaptors.
- Drivers can be replaced easily and fast without using any tools.
- Saves time by means of easy replacement of attachments.
- Light weight Aluminum-Titanium Alloy design allows easy operation even in rough conditions.



Specifications

- 700 bar maximum working pressure, Repeat Accuracy $\pm 3\%$
- 5 different model from 2625~48481 N.m.
- Fitted with $360^{\circ} \times 360^{\circ}$ Uni-Swivel quick release couplings.
- Low profile design to accessing limited areas.
- Drivers and adapters can be replaced easily.

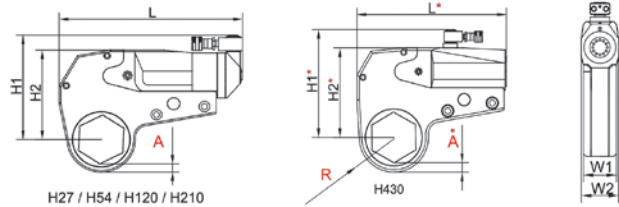

Optional

Reaction Pad	
Extending Reaction Arm	

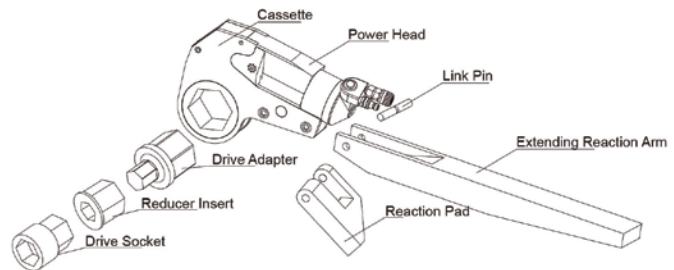

Ordering Information

Model No.	Torque (N.m)	Screw sizes(mm)	Weight N.W (kg)	L(mm)	H1(mm)	H2(mm)	W1(mm)	W2(mm)	A(mm)
H27	262-2625	19-46	1.8	193	125	97	32	51	10-15
	306-3068	50-60	1.8	193	136	108	32	51	10-11
H54	537-5372	27-65	3.8	250	158	125	41	64	11-19
	603-6037	70-80	3.8	250	169	136	41	64	11.7-12
H120	1173-11737	50-80	6.8	310	189	157	52	78	15-15.2
	1434-14349	85-105	6.8	310	214	182	52	78	16-22
H210	2121-21216	70-100	11.8	378	223	191	64	97	8-21
	2312-23124	105-115	11.8	378	236	204	64	97	18-24
H430	4379-43792	80-117	32.2	405	291	242	83	93	25-31
	4848-48481	120-175	32.2	425	309	260	83	93	25-34

HYDRAULIC TORQUE WRENCH AND TOOLS

Series Hexagon Cassette Selection Chart

H27				H54				H120			
Type	R(mm)	A(mm)	Max Torque (N.m)	Type	R(mm)	A(mm)	Max Torque (N.m)	Type	R(mm)	A(mm)	Max Torque (N.m)
H27-19	26	15	2625	H54-27	36	19	5372	H120-50	44	15	11737
H27-22	26	14	2625	H54-30	35	17	5372	H120-55	47	15	11737
H27-27	26	11	2625	H54-32	35	16	5372	H120-60	50	15	11737
H27-30	28	11	2625	H54-34	35	15	5372	H120-65	53	15	11737
H27-32	28	10	2625	H54-36	35	14	5372	H120-70	56	15	11737
H27-34	31	11	2328	H54-41	35	11	5372	H120-75	58	15	11737
H27-36	31	10	2625	H54-46	37	11	5858	H120-80	61	15	11737
H27-41	34	10	2625	H54-50	41	12	5372	H120-85	66	16	14349
H27-46	37	10	2625	H54-55	44	13	5372	H120-90	69	16	14349
H27-50	40	11	3068	H54-60	47	12	5372	H120-95	71	16	14349
H27-55	42	11	3068	H54-65	50	12	5372	H120-100	77	19	14349
H27-60	45	10	3068	H54-70	52	12	6037	H120-105	77	16	14349
				H54-75	56	12	6037				
				H54-80	58	12	6037				

H210				H430			
Type	R(mm)	A(mm)	Max Torque(N.m)	Type	R(mm)	A(mm)	Max Torque(N.m)
H210-70	59	18	21216	H430-80	72	25	43792
H210-75	62	18	21216	H430-85	78	28	43792
H210-80	65	18	21216	H430-90	78	25	43792
H210-85	68	18	21216	H430-95	84	28	43792
H210-90	71	18	21216	H430-100	84	26	43792
H210-95	74	18	21216	H430-105	90	28	43792
H210-100	77	18	21216	H430-110	90	26	43792
H210-105	79	18	23214	H430-115	94	28	43792
H210-110	82	18	23124	H430-117	94	28	43792
H210-115	87	21	23124	H430-120	101	31	48481
				H430-125	101	28	48481
				H430-130	101	25	48481
				H430-135	105	26	48481
				H430-140	110	29	48481
				H430-145	110	26	48481
				H430-150	115	29	48481
				H430-155	115	26	48481
				H430-160	121	29	48481
				H430-165	121	26	48481
				H430-170	128	30	48481
				H430-175	128	27	48481

HYDRAULIC TORQUE WRENCH AND TOOLS

IBT Series

Product Description

- IBT series is the professional hydraulic torque wrench which vigorously extends in international market.
- It's raw material is Aluminum-Titanium Alloy which makes the wrench light and high intense.
- IBT series has 10 models with the range from 112N. m to 72000N. m, covers the most of bolts size, and be the most comprehensive available in the market.



Specifications

- 700 bar maximum working pressure, Repeat Accuracy $\pm 3\%$
- The $360^{\circ} \times 185^{\circ}$ swivel is free to operation with no space limitation.
- The square drive operate with the high intense socket and suitable with large range of bolts.
- 360° adjustable reaction arm allows placing in any support point.
- Compact design with the raw material of advanced Aluminum-Titanium Alloy, high intense.
- The new locking coupler ensures smooth oil flow.

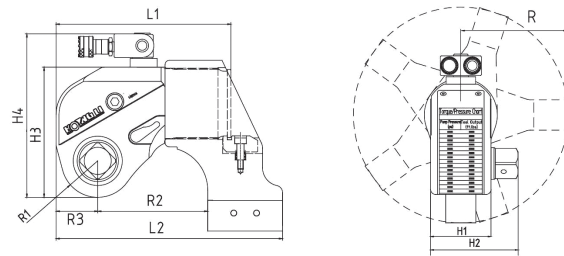

Special Reaction for Optional

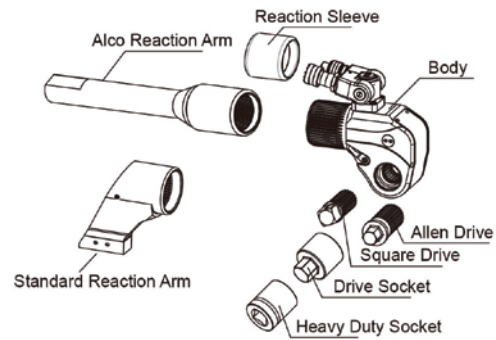

Ordering Information

Model No.	07IBT	1IBT	3IBT	5IBT	8IBT	10IBT	20IBT	25IBT	35IBT	50IBT
Torque (N. M)	112-1120	183-1837	451-4512	752-7528	1078-10780	1551-15516	2666-26664	3472-34725	4866-48666	7200-72000
Bolt Size(mm)	14-30	16-36	22-48	27-56	30-64	36-72	42-90	48-100	64-120	72-125
N.W(kg)	1.8	2.5	5	8	11	15	26.5	35	50	87
L1	110.8	144.5	178	210.5	222	245.5	307.5	323	372.5	400
L2	139.3	173.5	229	270.5	293	317.5	383.5	401	496.5	516
H1	42	50	68	80	90	100	120	137	153	160
H2	65.8	72	95	123	134	142	183	200	216	223
H3	76.2	96	127	149	167	182	220	247	282	291
H4	108.1	131	176.5	199	217	232	270	297	332	341
R	75	91.5	123.5	140	165	178	213	228	243.5	258
R1	20.5	26	34	39	47	51	59	66	77	81
R2	68.3	85	114	137	153	154	186	199	241	259
R3	25	29	40	46.5	47	58.5	71	66	79	97.5
Square drive	3/4"	3/4"	1"	1-1/2"	1-1/2"	1-1/2"	2-1/2"	2-1/2"	2-1/2"	2-1/2"

S Series

Product Description

- S series hydraulic torque wrench configured with high technology, with Aluminum-Titanium Alloy, ideal for long-term usage. With calibration service and support, S series hydraulic torque wrench can accomplish big missions efficiently.
- Almost every tightening & loosening problems can be accomplished with this series with MAX torque capacity up to 36992 N.m.
- A wide range of accessory for S series is available with us.



Specifications

- 700 bar maximum working pressure, Repeat Accuracy $\pm 3\%$
- 5 different models from 1727~36992N. m.
- 360° multi-positional swivel quick release couplings.
- Working with the high resistance sockets, suitable for Vari-ons sizes.
- 360° Adjustable reaction arm with safety lock, can be used without reaction arm.
- High resistance with light Aluminum-Titanium Alloy and light body.
- Replaceable square drive adapters.

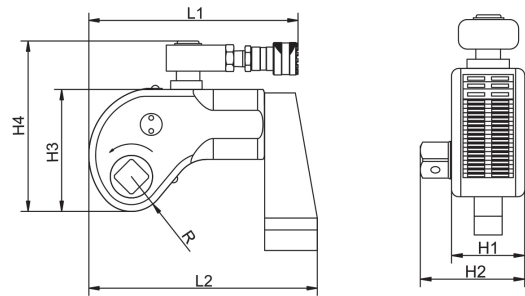

Ordering Information

Model No.	Torque (N.m)	Bolt size(mm)	Square Drive Inches	N.W(kg)	L1(mm)	L2(mm)	H1(mm)	H2(mm)	H3(mm)	H4(mm)	R(mm)
S17	172-1727	16~36	3/4"	2	129	167	51	73	90	131	25
S45	452-4529	22~48	1"	4.6	167	218	68	98	121	170	34
S100	1006-10064	30~64	1 1/2"	10	223	293	92	135	163	211	46
S150	1497-14974	36~72	1 1/2"	14.8	264	323	100	141	177	225	50
S370	3699-36992	48~100	2 1/2"	32.5	329	432	137	104	240	288	66

LOW/H Reducer Insert



Imperial and non-standard Reducer Inserts are available

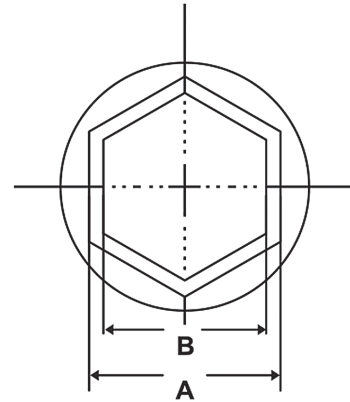

Ordering Information

Wrench Model	Cassette	Nut Size(S)	Reducer type						The locking ring type
			Type	A/B(mm)	Type	A/B(mm)	Type	A/B(mm)	
2LOW	2LOW-50	50	2G5041	50/41	2G5036	50/36	2G5032	50/32	H-50
	2LOW-46	46	2G4636	46/36	2G4632	46/32	2G4630	46/30	H-46
	2LOW-41	41	2G4132	41/32	2G4130	41/30	2G4127	41/27	H-41
	2LOW-36	36	2G3630	36/30	2G3627	36/27			H-36
	2LOW-32	32	2G3227	32/27					H-32
	2LOW-30	30							
	2LOW-27	27							
4LOW	4LOW-65	65	4G6555	65/55	4G6550	65/50	4G6546	65/46	H-56
	4LOW-60	60	4G6050	60/50	4G6046	60/46	4G6041	60/41	H-60
	4LOW-55	55	4G5546	55/46	4G5541	55/41	4G5536	55/36	H-55
	4LOW-50	50	4G5041	50/41	4G5036	50/36	4G5032	50/32	H-50
	4LOW-46	46	4G4636	46/36	4G4632	46/32	4G4630	46/30	H-46
	4LOW-41	41	4G4132	41/32	4G4130	41/30	4G4127	41/27	H-41
	4LOW-36	36	4G3630	36/30	4G3627	36/27			H-36
	4LOW-32	32	4G3227	32/27					H-32
	4LOW-30	30							
	4LOW-27	27							

HYDRAULIC TORQUE WRENCH AND TOOLS

Ordering Information

Wrench Model	Cassette	Nut Size(S)	Reducer type						The locking ring type
			Type	A/B(mm)	Type	A/B(mm)	Type	A/B(mm)	
8LOW	8LOW-90	90	8G9080	90/80	8G9075	90/75	8G9070	90/70	H-90
	8LOW-85	85	8G8575	85/75	8G8570	85/70	8G8565	85/65	H-85
	8LOW-80	80	8G8070	80/70	8G8065	80/65	8G8060	80/60	H-80
	8LOW-75	75	8G7565	75/65	8G7560	75/60	8G7555	75/55	H-75
	8LOW-70	70	8G7060	70/60	8G7055	70/55	8G7050	70/50	H-70
	8LOW-65	65	8G6555	65/55	8G6550	65/50	8G6545	65/45	H-65
	8LOW-60	60	8G6050	60/50	8G6046	60/46			H-60
	8LOW-55	55	8G5546	55/46	8G5541	55/41			H-55
	8LOW-50	50							
14LOW	14LOW-115	115	14G115105	115/105	14G115100	115/100	14G11595	115/95	H-115
	14LOW-110	110	14G110100	110/100	14G11095	110/95	14G11090	110/90	H-110
	14LOW-105	105	14G10595	105/95	14G10590	105/90	14G10585	105/85	H-105
	14LOW-100	100	14G10090	100/90	14G10085	100/85	14G10080	100/80	H-100
	14LOW-95	95	14G9585	95/85	14G9580	95/80	14G9575	95/75	H-95
	14LOW-90	90	14G9080	90/80	14G9075	90/75	14G9070	90/70	H-90
	14LOW-85	85	14G8575	85/75	14G8570	85/70	14G8565	85/65	H-85
	14LOW-80	80	14G8070	80/70	14G8065	80/65			H-80
	14LOW-75	75	14G7565	75/65					H-75
	14LOW-70	70							
	14LOW-65	65							
30LOW	30LOW-155	155	30G155145	155/145	30G155130	155/130	30G155120	155/120	H-155
	30LOW-145	145	30G145130	145/130	30G145120	145/120	30G145115	145/115	H-145
	30LOW-130	130	30G130120	130/120	30G130115	130/115	30G130110	130/110	H-130
	30LOW-120	120	30G120110	120/110	30G120105	120/105	30G120100	120/100	H-120
	30LOW-115	115	30G115105	115/105	30G115100	115/100	30G11595	115/95	H-115
	30LOW-110	110	30G110100	110/100	30G11095	110/95	30G11090	110/90	H-110
	30LOW-105	105	30G10595	105/95	30G10590	105/90	30G10590	105/90	H-105
	30LOW-100	100	30G10090	100/90	30G10085	100/85	30G10080	100/80	H-100
	30LOW-95	95	30G9585	95/85	30G95080	95/80			H-95
	30LOW-90	90	30G9080	90/80					H-90
	30LOW-85	85							
	30LOW-80	80							

HYDRAULIC TORQUE WRENCH AND TOOLS

IBT/S Series Sockets

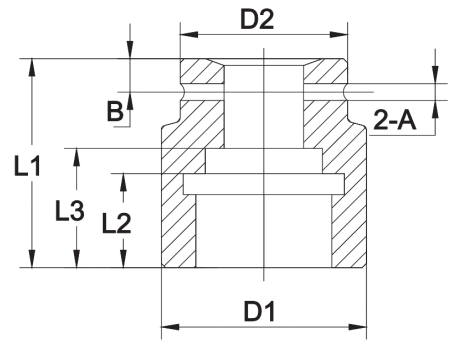

British and non-standard sockets can be customized

(mm)

Ordering Information

Bolt Type	3/4" 07IBT/11BT							1" 31BT							1-1/2" 5, 8, 10IBT							2-1/2" 20, 25, 35, 50IBT									
	D	N	A	B	L1	L2	L3	D1	D2	A	B	L1	L2	L3	D1	D2	A	B	L1	L2	L3	D1	D2	A	B	L1	L2	L3	D1	D2	
M16	24		6.3	10	54	32	32	40	40																						
M18	27		6.3	10	54	32	32	42	42																						
M20	30		6.3	10	54	33	33	46	44	8	14	59	32	32	54	54															
M22	34		6.3	10	54	33	33	52	44	8	14	59	32	32	58	58															
M24	36		6.3	10	57	33	33	54	44	8	14	62	32	32	59	59	8	16	85	44	44	74	74								
M27	41		6.3	10	58	33	33	60	44	8	14	65	38	38	67	54	8	16	85	44	44	74	74								
M30	46		6.3	10	63	38	38	66	44	8	14	65	38	38	74	54	8	16	85	44	44	74	74								
M33	50		6.3	10	65	40	40	71	44	8	14	70	43	43	79	60	8	16	90	45	45	79	79								
M36	55		6.3	10	70	45	45	77	54	8	14	80	42	52	84	60	8	16	90	45	45	84	84	8	18	100	57	57	86	114	
M39	60									8	14	85	45	57	89	60	8	16	100	45	57	94	75	8	18	100	52	52	119	119	
M42	65									8	14	85	45	57	98	70	8	16	100	45	57	98	80	8	18	100	52	52	119	119	
M45	70									8	14	90	50	62	104	70	8	16	105	50	62	104	80	8	18	120	67	67	128	128	
M48	75									8	14	95	50	65	108	70	8	16	110	50	65	118	90	8	18	120	67	67	128	128	
M52	80																8	16	115	55	72	118	90	8	18	130	71	71	128	128	
M56	85																8	16	125	60	77	128	90	8	18	130	71	71	129	129	
M60	90																8	16	125	60	77	139	90	8	18	140	61	73	139	139	
M64	95																8	16	130	65	82	139	90	8	18	140	66	73	139	139	
M68	100																8	16	135	70	87	144	90	8	18	140	71	81	148	130	
M72	105																8	16	135	70	87	149	90	8	18	150	77	89	156	130	
M76	110																8	16	135	70	87	158	90	8	18	150	72	90	158	130	
M80	115																8	16	135	70	87	159	95	8	18	150	82	98	168	130	
M85	120																8	16	135	70	87	168	95	8	18	150	82	98	178	130	
M90	130																8	16	155	93	105	189	95	8	18	170	93	114	189	130	
M95	135																								8	18	170	93	114	198	130
M100	145																								8	18	170	98	122	210	152
M105	150																								8	18	190	100	140	216	152
M110	155																								8	18	190	100	140	229	152
M115	165																								8	18	190	100	140	241	152

The Choosing Of Hydraulic Torque Wrench

Strength Grade		4.8		6.8		8.8		10.9		12.9	
Min Breaking Strength		392Mpa		588Mpa		784Mpa		941Mpa		1176Mpa	
Material		Q325(SS41)		35(S35C)		35CrMo(SCM3)		42CrMo(SCM4)		40GrNiMoA(SNCM)	
Bolt	Diameter	Torque		Torque		Torque		Torque		Torque	
M (mm)	S(mm)	KGM	N. m	KGM	N. m	KGM	N. m	KGM	N. m	KGM	N. m
14	22	7	69	10	98	14	137	17	165	23	225
16	24	10	98	14	137	21	206	25	247	36	363
18	27	14	137	21	206	39	284	35	341	49	480
20	30	18	176	28	296	41	402	58	569	69	680
22	32	23	225	34	333	55	539	78	765	93	911
24	36	32	314	48	470	70	686	100	981	120	1176
27	41	45	441	65	637	105	1029	150	1472	180	1764
30	46	60	588	90	882	125	1225	200	1962	240	2352
33	50	75	735	115	1127	150	1470	210	2060	250	2450
36	55	100	980	150	1470	180	1764	250	2453	300	2940
39	60	120	1176	180	1764	220	2156	300	2943	370	3626
42	65	155	1519	240	2352	280	2744	390	3826	470	4606
45	70	180	1764	280	2744	320	3136	450	4415	550	5390
48	75	230	2254	350	3430	400	3920	570	5592	680	6664
52	80	280	2744	420	4116	480	4704	670	6573	850	8330
56	85	360	3528	530	5149	610	5978	860	8437	1050	10290
60	90	410	4018	610	5978	790	7742	1100	10791	1350	13230
64	95	510	4998	760	7448	900	8820				
68	100	580	5684	870	8526	1100	10780				
72	105	660	6468	1000	9800	1290	12642				
76	110	750	7350	1100	10780	1500	14701				
80	115	830	8143	1250	12250	18580	18130				
85	120	900	8820	1400	13720	2250	22050				
90	130	1080	10584	1650	16170	2500	24500				
100	145	1400	13720	2050	20090						
110	155	1670	16366	2550	24990						
120	175	2030	19894	3050	29890						

- This is Germany standard(DIN) above, the figure in the form is the max torque of the bolt, and the recommended torque is 80% of chart figure.
- The recommended tightening torque equals the figure in the form×(80~90%). For instance:M52, strength grade is 8.8 , the torque is 4704×90%=4233.6N. m
- It is recommended that loosening torque equals about 150% of tightening. For instance, the tightening torque is 4233.6×(1.5~2)=6350.4~8467.2N. m

The Space

Because of the Space restriction, please notice the location, For example:

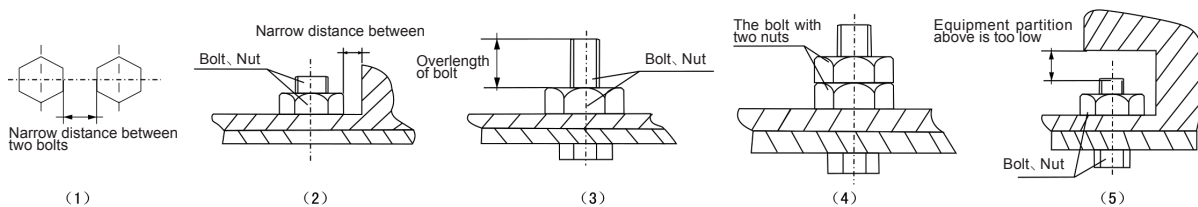

The conditions above, please use Low Profile Wrench instead of square drive type.

HYDRAULIC TORQUE WRENCH AND TOOLS

Torque Wrench Pump

LP3

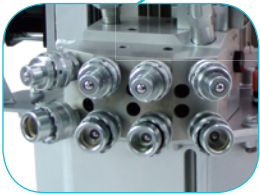
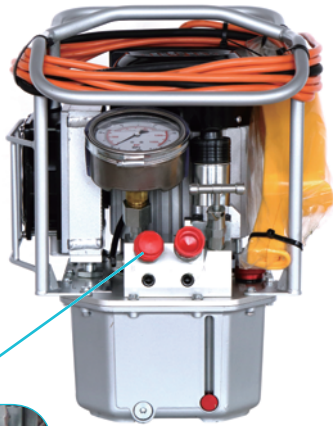

Optional

Product Description

- Compact automatic three stage flow, max efficiency.
- Applicable on both one or two wrenches simultaneously.
- Aluminum oil tank with oil gauge and thermometer.
- $\Phi 100$ high pressure gauge.
- Working pressure: 40~700 bar
- With efficient radiator, the pump can work 24 hours continuously.
- The motor can be changed according to the different voltage.
- You can use manifold to operate 4 wrenches simultaneously.

Specifications

Model	LP3-2	LP3-4
Operating Wrench	2	4
Tank Capacity	5.5L	5.5L
Flow(Low-Mid-High)	7-1.6-0.8L/min	7-1.6-0.8L/min
Output Pressure	70~700bar	70~700bar
Voltage	220V/50HZ	220V/50HZ
Power	1.1KW	1.1KW
Weight	25kgs	27kgs
Volume	30.5×44.5×42.6cm	30.5×44.5×42.6cm

LP3-N

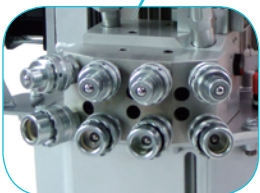
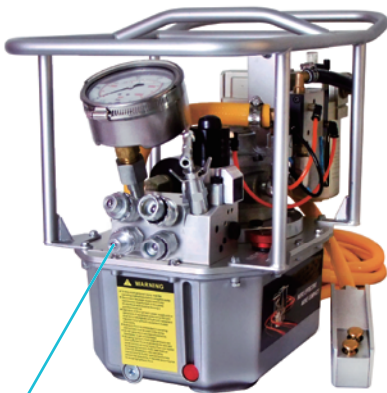

Optional

Product Description

- Compact three-stage pump.
- The Single valve block can be replaced by component FP4, there by allowing 2or 4 Tools to be driven simultaneously.
- Three stage with air drive.
- Supporting continuous operation with steel frame.
- 4" diameter gauge, aluminium oil tank with oil level indicator.
- Variable pressure adjustment between 70~700 bar.
- Designed for continuous operation.

Specifications

Model	LP3-N2	LP3-N4
Operating Wrench	2	4
Air Pressure(Input)	4~8 bar	4~8 bar
Tank Capacity	5.5L	5.5L
Flow(Low-Mid-High)	8.6.6-2.2-1.1L/min	8.6.6-2.2-1.1L/min
Output Pressure	70~700bar	70~700bar
Voltage	220V/50HZ	220V/50HZ
Power	3KW	3KW
Oil outputs	4×1/4" NPT	8×1/4" NPT
Weight	22kgs	24kgs
Volume	44.2×28.2×37.7cm	46×28.2×37.7cm

Torque Wrench Pump

KLW4010

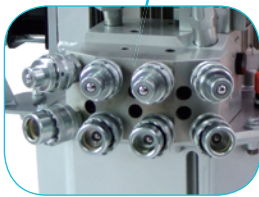

Optional

Product Description

- Compact automatic three stage design.
- Applicable on one or two wrenches simultaneously.
- Aluminum oil tank with gauge.
- $\Phi 100$ high pressure gauge.
- Infinitely variable pressure adjustment between 70~700 bar.
- With the high efficiency radiator the pump can work 24 hours continuously.
- Can change the motor to fit the different voltage.
- Optional components, can operate four wrenches at the same time.

Specifications

Model	KLW4010-2	KLW4010-4
Operating Wrench	2	4
Tank Capacity	8L	8L
Flow(Low-Mid-High)	7-1.6-0.8 L/min	7-1.6-0.8 L/min
Output Pressure	70~700bar	70~700bar
Voltage	220V/50HZ	220V/50HZ
Power	1.1KW	1.1KW
Weight	27.7kgs	29.9kgs
Volume	40.7×30.7×45cm	40.7×30.7×47cm



Torque Wrench Pump

KLW4010N

Product Description

- Input air(4~8 bar).
- Compact automatic three stage flow, can start in high pressure
- Applicable on one or two wrenches simultaneously
- Aluminum oil tank with oil gauge. Total weight only 21.5 kg
- Have $\Phi 100$ high pressure gauge
- Infinitely variable pressure adjustment between 70~700 bar
- With the high efficiency cooling system makes the pump suitable in extreme environment
- Optional components(FP4), can operate four wrenches at the same time

Specifications

Model	KLW4010N-2	KLW4010N-4
Operating Wrench	2	4
Tank Capacity	8L	8L
Flow(Low-Mid-High)	8.6-2.2-1.1 L/min	8.6-2.2-1.1 L/min
Output Pressure	70~700bar	70~700bar
Air in	4~8 bar	4~8 bar
Power	3KW	3KW
Weight	21.5kgs	23.5kgs
Volume	28.9×40.7×45cm	28.9×40.7×47cm

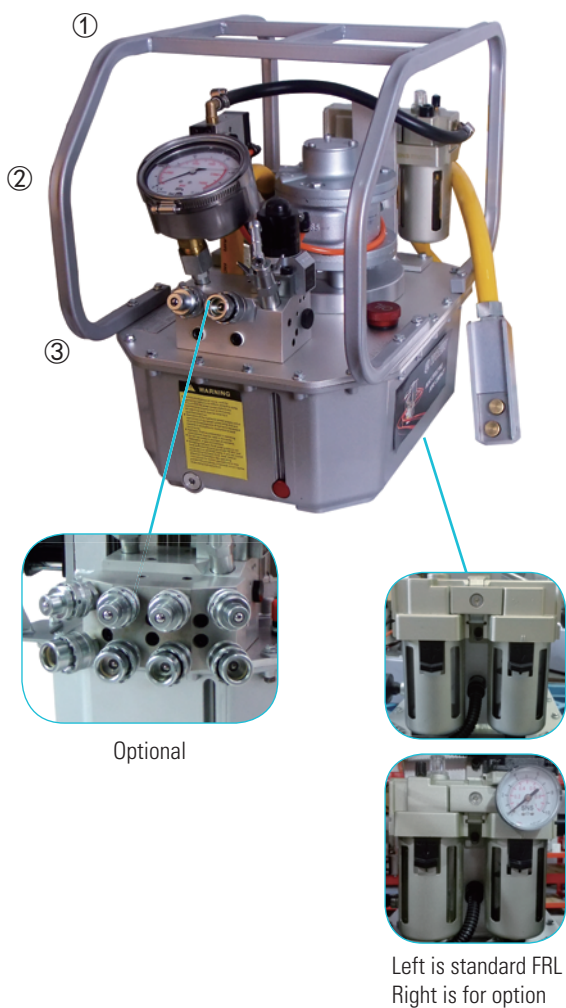

① Pressure Relief Button, it can release the pressure in system in the case of Pump stopped.

② Air Relief Port, make sure Air Driven Pump can be operated in cold and hot condition.

③ Pressure Adjustor, Pressure Relief valve (inside the tank)

Semi-automatic Electric Pump

KLW4120



Product Description

• KLW4120 Series Automatic Electrical Pump shared a same design with KLW4000 series standard Electrical Pump, added a set of control system (import from Germany) on the basic of KLW4010 standard Pump, it inherited all the characteristics of KLW4010, some other characteristics of this Pump are as below:

• Simple Operation:

Operate with one Button, the operator just need to press down the button one time to achieve the operation of tightening and loosening.

• High Efficiency:

Compare with the general Pump, KLW4120 Automatic Pump has compact operation process to reduce some needless action and increase approximate 50% of working efficiency.

• Manual / Automatic

Besides of the automatic operation, the Pump also has the function of manual operation, for some special operation, KLW4120 also can work well.

Additionally the KLW4120 can work 24 hours without stop with radiator, We can also make the Pump with other kinds of motors according customers' requirement.

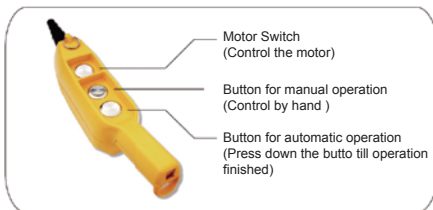

Specifications

Model	KLW4120-2	KLW4120-4
Operating wrench	2	4
Tank capacity	8L	8L
Flow(low-mid-High)	7-1.6-0.8 L/min	7-1.6-0.8 L/min
Out put pressure	70~700bar	70~700bar
Voltage	220V/50HZ	220V/50HZ
Power	1.1KW	1.1KW
Weight	27.7KG	29.7KG
Volume	29.9×44.5×44.6cm	29.9×46.5×44.6cm

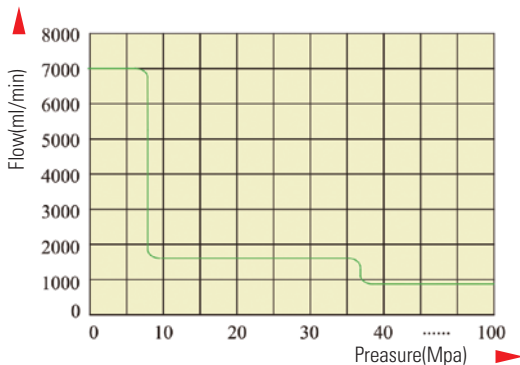

Drawing of Flow Description for KLW4120

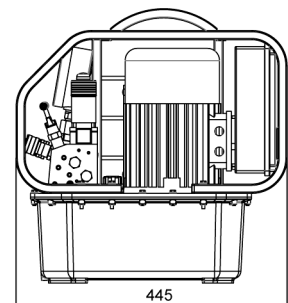
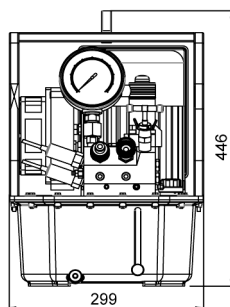

Electric Torque Wrench-WED Series



Product Description

- High performance bolting tool with automatic digital torque
- Digital set point
- Password protection
- Torque control during loosening
- Life time cycle counter for maintenance
- Repeatability $\pm 3.5\%$
- Custom programming



"M" Function Key: Preset, Maint. Count, Life Count, Information, Password, Back.

Torque Setting

- The torque can be set with the membrane key control
- To select the torque push the middle button "M"
- With the arrow buttons one can change the torque value
- Push the button "M" to confirm the set torque value. Torque setting is completed now. Hereupon the angle of rotation can be set, in case this option is available.
- The angle value is selected. Please follow steps 3 and 4 to change the angle value.



Torque Setting

Specifications

Type	Square Drive	Torque (ft.lbs)		RPM (min-1)	Weight (lbs)	Dimensions (inch)			
						A	B	C	D
WED14	3/4"	140	1400	9	3.8	310	63	72.9	210
WED21	1"	214	2149	5	6.7	445	76	73	210
WED34	1"	339	3398	4.5	7	457	76	73	210
WED80	1 1/2"	800	8000	4	11.8	500	102	73	210

Operation:



Tightening

Loosing

