



D&R INDUSTRIES

D&R INDUSTRIES CO.,LTD

Tel: 86-574-83080933 87830056

Fax:86-574-87839559

Email: danielge20@gmail.com

busi@dr-machinery.com

Web-Site:www.dr-machinery.com

D&R Industries With Many Years Experience In Confectionery Line And High Technology Team , Giving The Whole Project Solution And Consulting For Candies, Gummy, Chocolate And Its Packing.

D&R Always Giving The Economic Machine, Better Quality, Better Service After Sales For All Of The Customer.



D&R INDUSTRIES

PACKING MACHINE



KEEP DEVELOPING & RESEARCHING FOR CONFECTIONERY MACHINE

SPECIFICATION

Display	10.4 Inch touch screen
Weigh head nos	14
Weigh volume	0.5L
Hopper material	304 Stainless steel
Single weighing range	10-500g
Max.weigh	1000g
Weighing accuracy	±0.3~1.5g
Max width of roll film	400mm
Bag width	60~190mm
Bag length	50~230mm

Packaging film material	Complex film
Film drive power	Servo motor
End seal power	Servo motor
Air consumption	0.2m ³ /min,0.6Mpa
Max.packing speed	100 bags/min
Power	5KW
Voltage/frequency	220V 50/60Hz (alternative)
NW./GW.	540kg/740kg
Package size(mm)	1556*1366*2078

PURPOSE AND CHARACTERISTIC

Main performance and functional characteristics :

- 1.Equipped with safety protection, conform to firm's safety management requires.
- 2.Use intelligent temperature controlling machine to have accurate temperature control; ensure the artistic and neat seal.
- 3.Use PLC control servo electrical double-pull or single pull membrane structure, super touch screen structure drives the control center; maximize the whole machine's control precision, reliability and intelligentized level.

- 4.This machine completes the whole packing procedure of measuring, loading materials, bagging, date printing, charging (exhausting)and products transporting automatically as well as counting.
- 5.Have error indicating system, helping handle the trouble immediately.
- 6.Make block bags and hanging bags according to customers' different requires.

Selected installations:
 Measuring cup equipment
 Screw measuring equipment
 Electronic automated measuring steelyard
 Mixed steelyard

Usage:
 Suit for automatic packing of popped food, fruit, candy, biscuit, deep-frozen food, melon seeds, roasted nuts, pips and other granule materials.

SPECIFICATION

Model	DRRL420	DRRL422	DRRL530
Bag size	L 80-300mm W 80-200mm	L 80-300mm W 80-200mm	L100-350mmW100-250mm
Packing speed	25-80bags/min	2×80bags/min=160 bags/min	25-70 bags/min
Electrical source and power	AC220V, 50-60Hz, 3.0KW	AC220V, 50Hz-60Hz, 6.0KW	AC220V, 50-60Hz, 5KW
Air pressure and gas cost	6-8kg/m ² ,0.15m ³ /min	6-8kg/m ² ,0.3.m ³ /min	6-8kg/m ² , 0.25m ³ /min
Weight	500kg	950kg	700kg
Outer dimension	L1650×W1300×H1700mm	L1800×W2020×H1550mm	L1600×W1150×1800mm

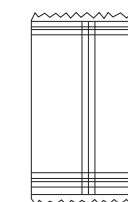
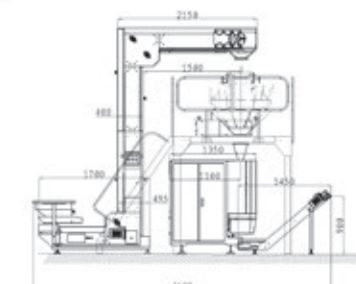
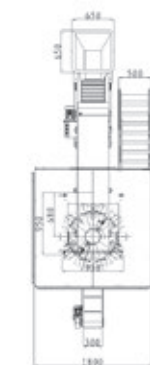
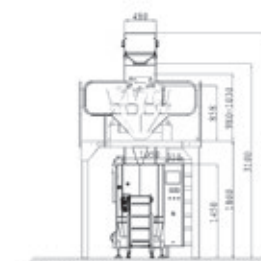
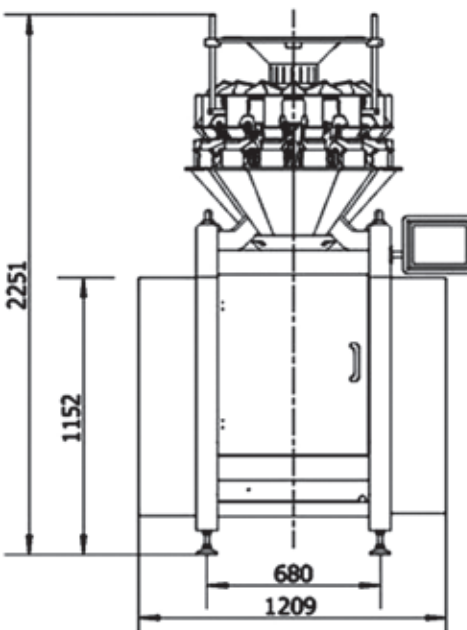
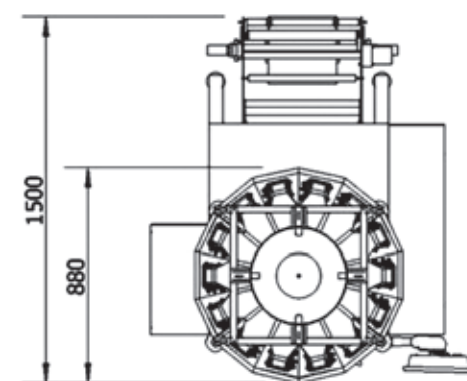

DRBF STAND-UP QUAD-SEAL PACKING MACHINE

OPTIONAL DEVICES

- Nitrogen gas flushing
- Hole punch device
- Safety device
- Static eliminator
- Bag support
- Film tracking device

SPECIFICATION

Model	DRBF-320	DRBF-430	DRBF-520
Film width	260-320mm	260-430mm	280-520mm
Bag length	Max 230mm	Max 300mm	Max 350mm
Packing speed	Max 50bags/min	Max 50bags/min	Max 50bags/min
Electrical source and power	220V, 50-60HZ, 3KW	220V, 50-60HZ, 4.5KW	220V, 50-60HZ, 5KW
Compressed air	0.3m ³ /min, 0.6MPa	0.3m ³ /min, 0.6MPa	0.3m ³ /min, 0.6MPa
Outer dimension	1300X960X1500mm	1550X1160X1880mm	1260X1600X2080mm



LOLLIPOP BUNCH WRAPPING MACHINE

SPECIFICATION

Model	DRLP-150
Wrapping material	OPP, PVC, OPP/OPP, PT/PE etc.
Film size	Maximum 125x125mm
Lollipop size	Dia22-dia30mm
Packing speed	2000kgs/day (based on dia25 lollipop)
Total power:	2.2kw
Machine size	2500x920x1520mm
Machine weight	1200kgs

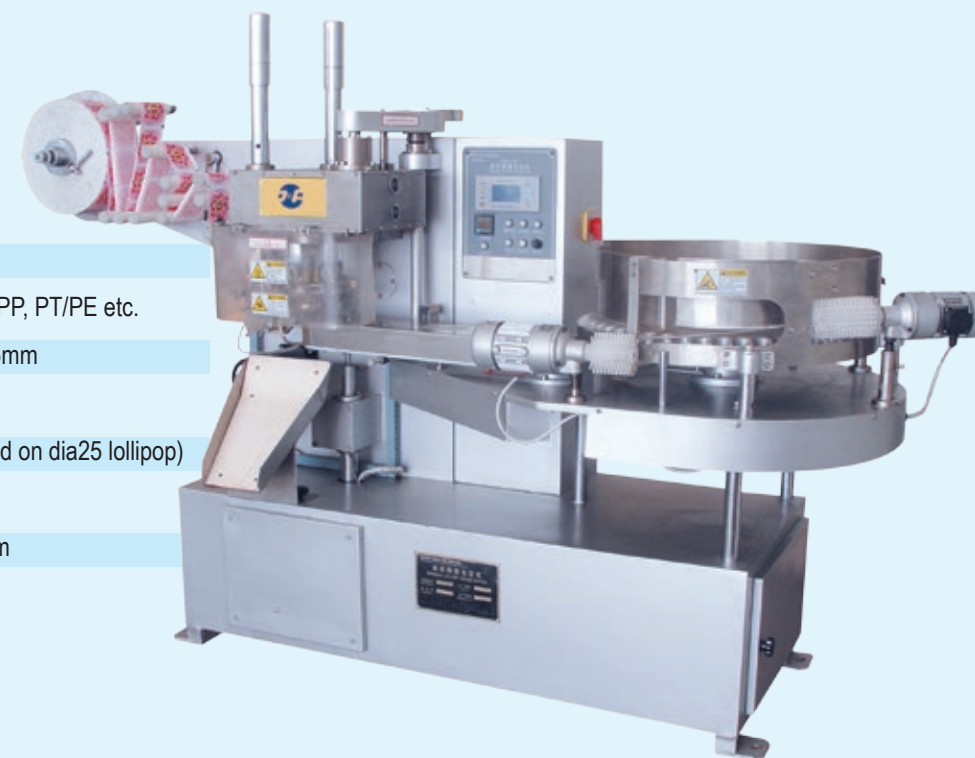

SPECIFICATION

Model	DRLP-400
Wrapping material	OPP, PVC, OPP/OPP, PT/PE etc.
Film size	Maximum 125x125mm
Lollipop size	Dia22-dia30mm
Packing speed	300-350pcs/minute
Total power	5kw
Machine size	2395x1665x1900mm
Machine weight:	2000kgs



FEATURES

- Speed controlled by inverter
- Inspection of autocontrol photocell scan
- Automatic multifunction alert system: showing the breakdown information , cause and automatic stopping machine
- Auto material feeding system: vibrating supplying and feeding material
- The servo driven paper feeding system
- Automatically code printing system
- Multilayer double multi-purpose packing



SPECIFICATION

Packing figure	Column
Product size	Diameter: $\Phi 17 \sim \Phi 24$ mm
	Thickness: 6~12mm
	length: 30~130mm
packing speed	1000~ 2000pcs/min
power supply	380V 50Hz
power	3kw
size of machine	(L)5900mmX(W)1650mmx(H)1750mm
weight of machine	1800kg



HIGH-SPEED AUTOMATIC FLOW WRAPPING MACHINE

SPECIFICATION

Model	DZB-898C
Application	Oblong, quadrate, round, oval and shaped candies
Packing speed(per minute)	≤600pcs
Film length	45-80mm
Power	3.5kw
Machine size	3000X1350X1450mm



SPECIFICATION

Model	DZB-1000
Application	Oblong, quadrate, round, oval and shaped candies
Packing speed(per minute)	≤1200pcs
Film length	45-80mm
Power	3.5kw
Machine size	3500X1350X1800mm



SPECIFICATION

Model	DZB-280
Application	Biscuit, chocolate, moon cake, bread, popsicle, yolk pie, soap, card and etc.
Packing speed(per minute)	≤280pcs
Film length	70-150mm, 140-260mm
Power	3kw
Machine size	4000X950X1450mm



NYS-800

DOUBLE-TWIST CANDY WRAPPING MACHINE

PURPOSE AND CHARACTERISTIC

This machine with feeding disk for candies wrapped in double twist with one or two papers. 100percent of packing, no empty package. The color code of computer photoelectric automatic track. Speed adjusting offrequency conversion

SPECIFICATION

Packing speed(per minute)	≤500pcs
Wrapping material	Cellophane, PVC, Polypropylene, waxed paper, complex material, etc
Product size	length 12-34mm, width 12-34mm, thickness 6-20mm
Power	2.2kw
Machine size	1800x950x1650mm

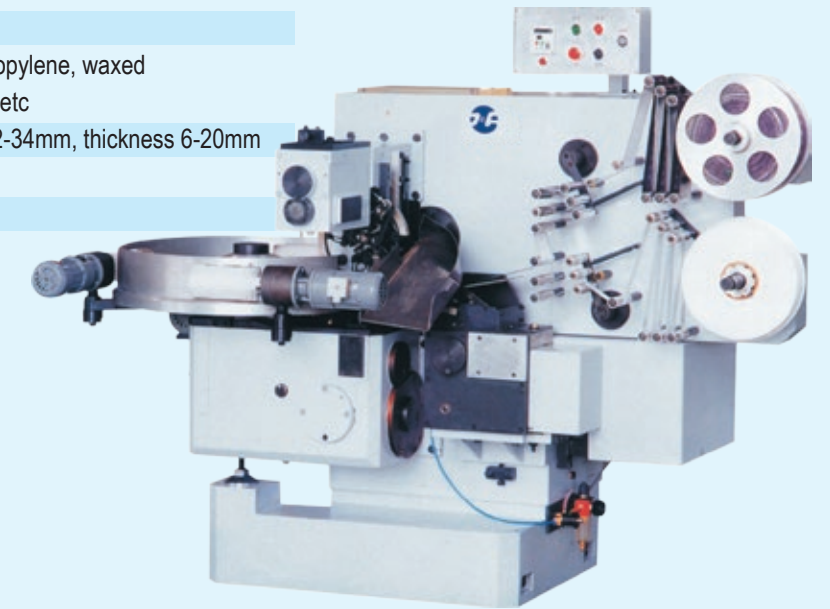

NYS-D800

SINGLE-TWIST CANDY WRAPPING MACHINE

PURPOSE AND CHARACTERISTIC

This machine with feeding disk for candies, wrapped in single twist package with one or two layers of paper. PLC control. 100 percent of packing, no empty package. The color code photo-electric automatic track. Speed adjusting by frequency conversion.

SPECIFICATION

Packing speed(per minute)	≤350pcs
Product size	length 12-32mm width 12-26mm, thickness 6-20mm
Power	2.5kw
Machine size	2030x1250x1810mm



PURPOSE AND CHARACTERISTIC

The wrapper is designed and improved using the advanced structures of similar machines introduced from foreign countries for reference. With functions of both sheet-cutting and wrapping,the machine can carry out the primary, secondary and overall wrapping for chewing gum in order,and track the whole process automatically.the machine has many advanced features,such as higher speed,lower noise,easier operation,and pleasant final-product appearance.



PACKING SIZE AND SPECIFICATION

Item	parameter	
Pack size	uncovered sheet:	72x19x1.8mm
	Single sheet:	74x20.5x2.2mm
	Five sheet pack:	75.5x21x11.4mm
	Seven sheet pack:	75.5x21x15.8mm
Wrapping material size	primary wrapping:	49µm micron(thick)
	Overall wrapping:	49µm micron(thick)
	Secondary wrapping:	70µm micron(thick)
	Tear tape:	60µm micron(thick)
Wrapping speed	600sheet/min	
Power	2.85kw(motor:2.5kw,wax sealing:2.0kw,control system:0.1kw)	
Overall dimension	length x width x height:3500 x 1500 x 2000mm	
Machine weight	1800kg	

PURPOSE AND CHARACTERISTIC

Adopt micro-computer control technique,track color mark all to matically,accurate and reliable. Compact structure, reliable function. Temperature controlled independently,sealing is beautiful and firm.

SPECIFICATION

Capacity	60 strip/min
Drive power	1.25kw
Heating power	0.6kw
Overall dimension	1396x1550x2000mm

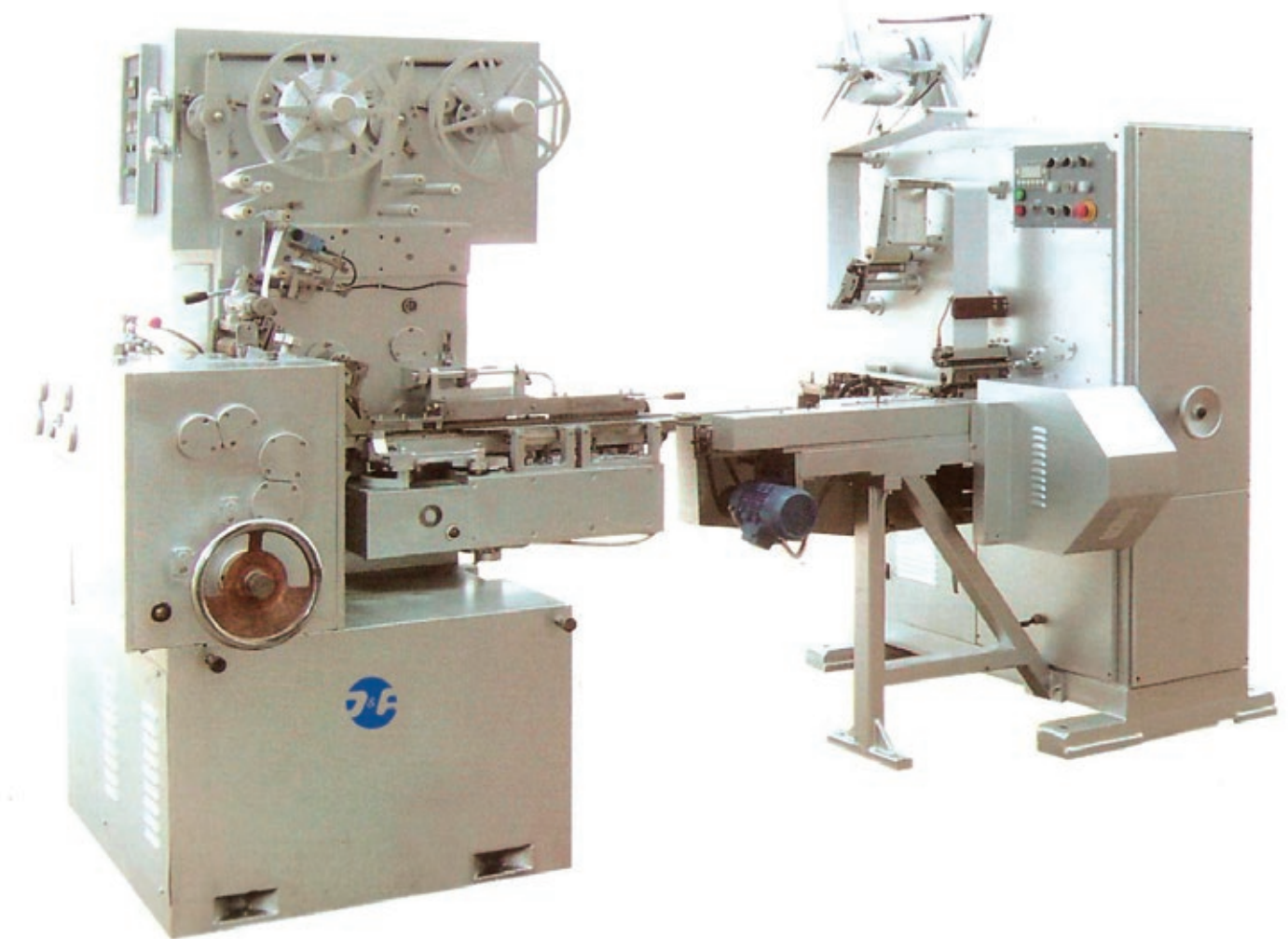

USE

suit for packing chocolate,hard candy

PURPOSE AND CHARACTERISTIC

Monolayer double multi-purpose packing

we use hot gluing or hot sealing for the packaging

Speed controlled by inverter

Automatic fault alarm system,show the position of fault,alarm in time,and automatic stop the machine

Photocell scanner system,making cutting position correctly.no candy no film feeding

it can be connected to the moulding machine of chocolate,for the automatic packaging



SPECIFICATION

Packing figure	Oblong	Square
Product size	Length: 40-90mm Width: 40-110mm	
packing speed	150~ 200pcs/min	
voltage	380V/Hz	
power	4.07kw	
size of machine	5360x2100x2100 cm	
weight of machine	1500kg	

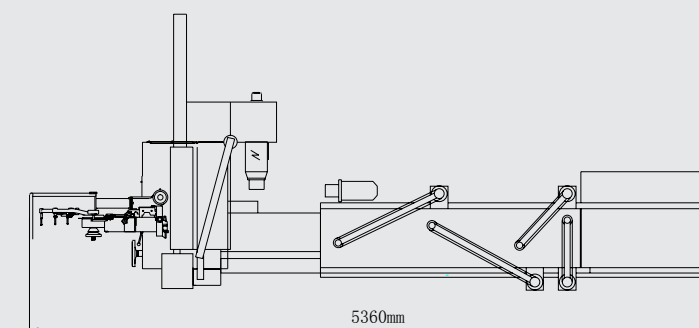
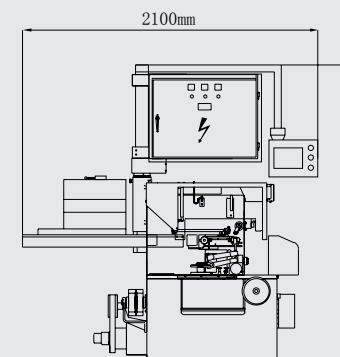
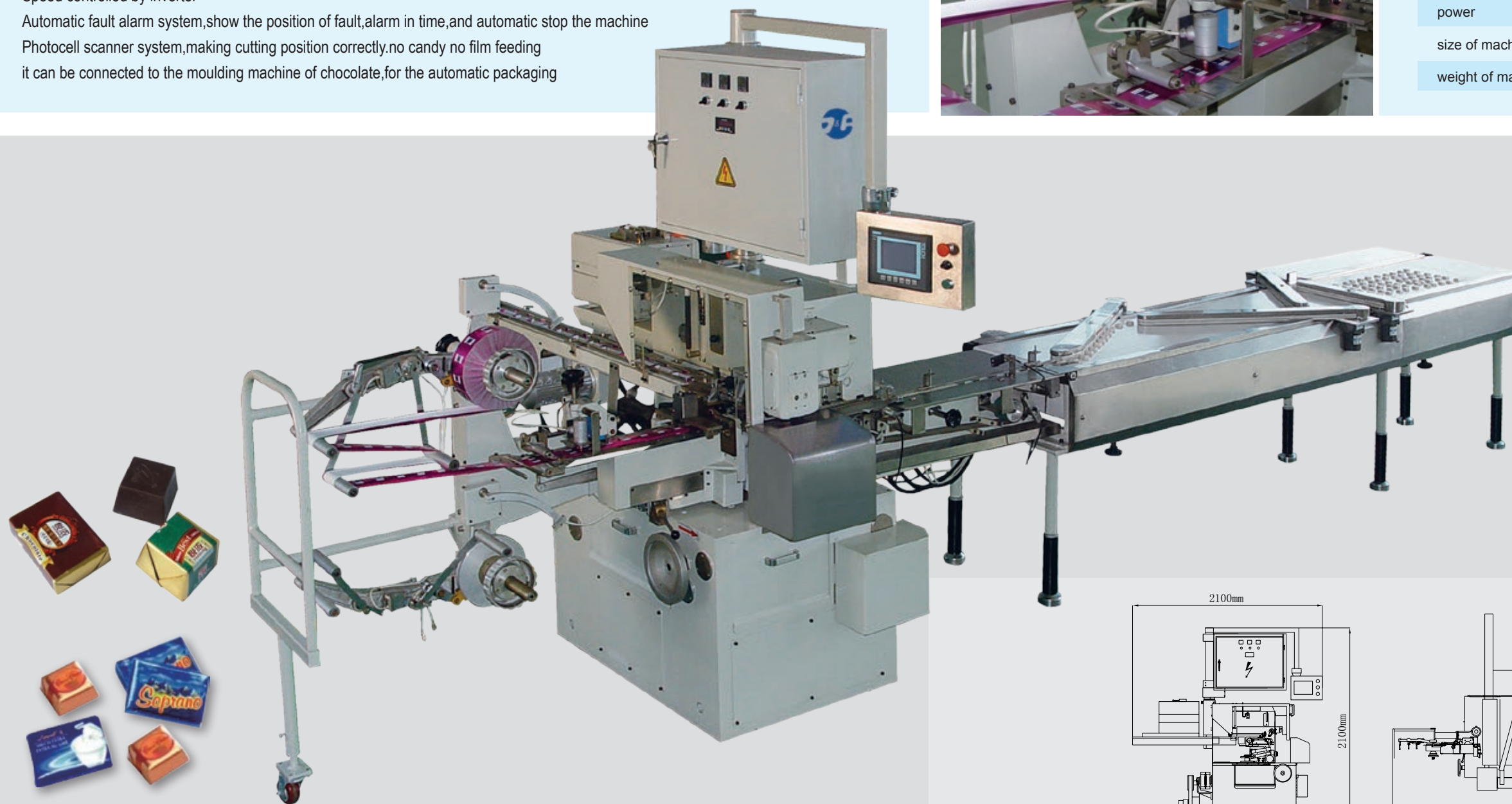

PURPOSE AND CHARACTERISTIC

This machine built accordated technology according to a logical,linear path,cutting and wrapping.The cam movement with gear transmission is powered by a three phase asynchronous motor activated by an inverter,Automatic lubrication with shower distribution: the oil is kept in a removable tray.

All operations of the machines are controlled by PLC.Size change and production start-up are very ropid,because the parts to be replaced are always housed in a precise position,with no need for adaptation or adjustments,Recels are fast and easy to change.All parts in contact with the products are made from non-toxie materials suitable for use with foodstuffs.

SPECIFICATION

Item	Parameter
Wrapping speed	Variable from 350-500 pieces per minute based on the wrapping material used.
Power supply	380V 50Hz ± 10%
Total absorbed power	3.55kw
Dimensions	1450x1200x1750mm
Weight	1400kg
Wrapping materials	external: paper ,cellophane, aluminium

PURPOSE AND CHARACTERISTIC

The wrapper can be used to pack bubble gum and cream candy in pillow-type.The machine is a combination of guillotine cutter and pillow-type wrapper,i.e, it can cut suger rope and mold into required shape,and then put candy into the wrapping machine,Therefore,the efficiency of the machine is very high and it is quite easy to keep the sanitary condition. The wrapper offers an deal choice for confectionary manufacturers.

SPECIFICATION

Item	Parameter
Main motor	2.2kw 380V
Wrapping speed	300 pcs/min
Longitudinal sealing heater	400W x 2 220V
Transverse sealing heater	150W x 8 220V
Overall dimension	2120 x 1020 x 1700mm
Machine weight	1000kg

