



# Lab Powder Coating Booth Operation Manual



## CAUTION

Read rules for safe operation and instructions carefully!



高压!

维修前切断电源! High voltage! Cut of the power before repair!

Hangzhou Color Powder Coating Equipment Co.,Ltd  
Phone: (86) 8819 4898 - Fax: (86) 85335616

[www.colourspray.com](http://www.colourspray.com) - [www.hi-colo.com](http://www.hi-colo.com)

<b>1. Product introduction.....</b>	<b>- 1 -</b>
1.1 Application.....	- 1 -
1.2 Product composition and schematic drawing.....	- 1 -
1.3 Main technical data.....	- 2 -
1.4 Operational principle and schematic drawing.....	- 2 -
<b>2. Installation and notice.....</b>	<b>- 3 -</b>
2.1 Installation site requirement.....	- 3 -
2.2 Installation interval requirement.....	3
2.3 Installation and testing.....	3
2.4 Installation notice.....	3
<b>3. Operation and notice.....</b>	<b>4</b>
3.1 Operation procedure.....	4
3.2 Powder change.....	4
3.3 Operation notice.....	4
<b>4. Daily maintenance and protection.....</b>	<b>5</b>
<b>5. Common troubleshooting.....</b>	<b>5</b>



**Advice:** This operation manual includes the detail descriptions of how to use , repair and maintain the equipment. In order to ensure your personal and property safety, please read all the details of this operation manual before installation and initial startup!

## 1. Product Introduction

### 1.1 Application

Small spray booth is mainly used for powder recovery process in the production of workpiece spraying. While powder spray, powder can not be completely adhesive on the workpiece, through the filter can recycle it again. Small spray booth is suitable for spraying the small workpiece, put the workpiece which already finished the pretreatment in the spray booth, switch on power, and then start to spray.

### 1.2 Product composition and schematic drawing

Lab spray booth mainly consist of the spray chamber、 filter、 fan motor etc. By Utilizing the wind speed which generated by fan motor can help the filter more better to adhesive the powders, also be able to help the workpiece more better to adhesive the powders. Filter is detachable, can be changed at will, can be more convenient to change color.

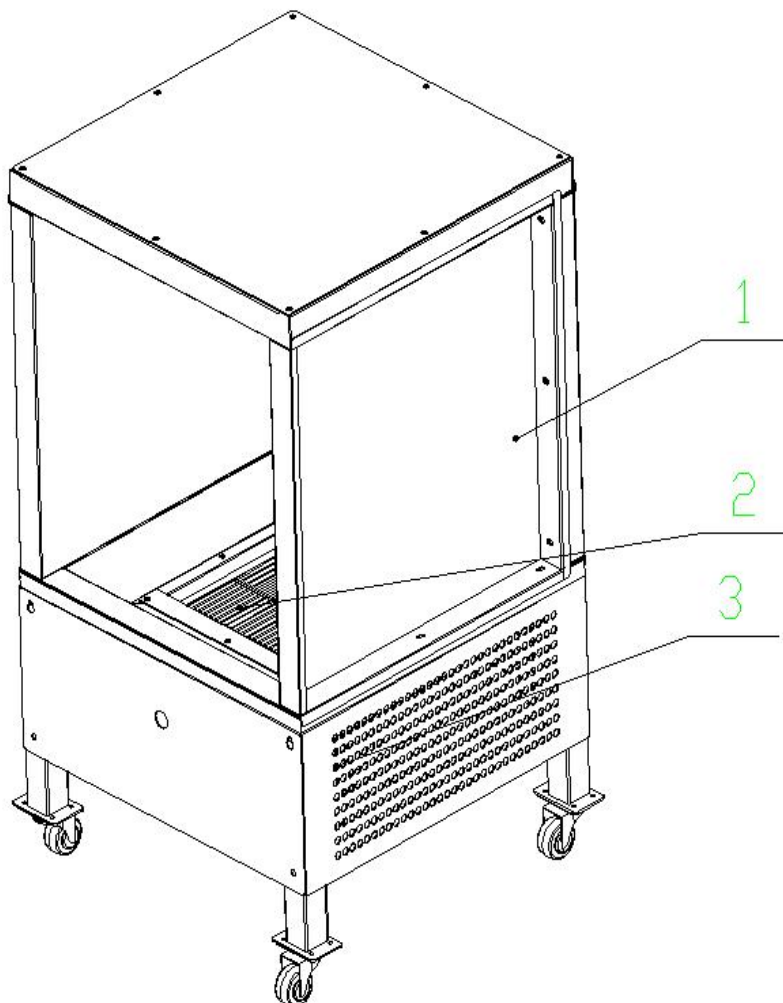

Project	Description	Quantity
1	Spray booth chamber	1
2	filter	1
3	fan motor	1

## 1.3 Main technical data

- a) : 440×500×480mm (W×H×D)  
Effective inner size of spray booth:
- b)  
Working temperature: -10~40℃
- c) Fan motor: 75w

## 1.4 Operational principle and schematic drawing

Small spray booth is forming a closed spray space by sheet metal, operator put the workpiece on the hanger and use the spray gun to do powder coating, utilize the air flow that generated by fan motor on the bottom of spray booth, make the excess powder adhesive on the filter. Small spray booth can spray small workpiece, need less space, can easy operation and more convenient for color change.

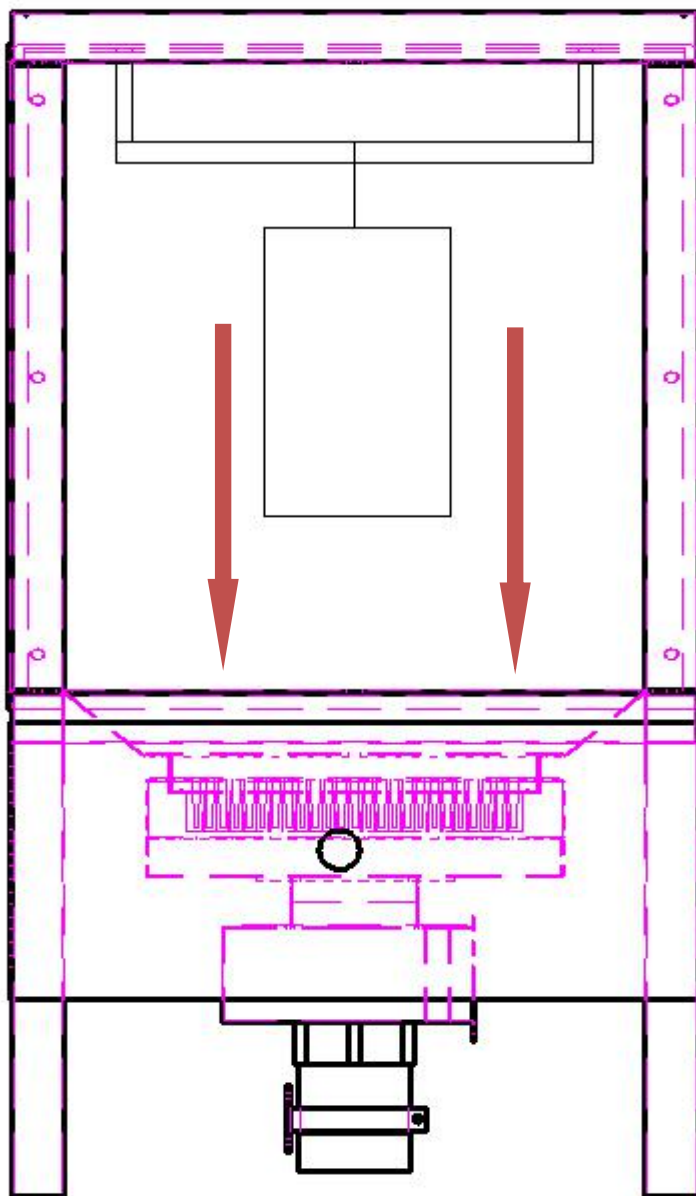

## 2. Installation and notice

**Advice:Familiar with related operation manual before installation and initial start-up!**

### 2.1 Installation site requirement

- a) The ground must be flat.
- b) Good ventilation and less dust place.
- c) Do not install in the wet place.
- d) Do not install in flammable or corrosive gases.

- e) Ambient temperature can not be too high, preferably between 0--40.

## 2.2 Installation interval requirement

- a) The booth should keep a distance of 10cm to the wall, in order to facilitate the normal operation of the machine.
- b) Keep a foot distance between machines, in order to facilitate the air circulation, personal maintenance.
- c) : 520×520×940mm (L×W×H)  
Outside dimension of spray booth: 520×520×940mm (L×W×H)

## 2.3 Installation and debugging

- a) Install and fasten the small spray booth well by following the requirements of 2.1 and 2.2 to
- b) Switch on the power by follow the operation procedure .
- c) Check inside filter and fan motor whether both can work properly

## 2.4 Installation notice

- a) Please follow the specification for electrical equipment (3 phase voltage) to supply the voltage. (380V)。
- b) The voltage change rate must be controlled at the rated value of + 10V
- c) Check 3 phase whether loss of phase, machine can not be operated in broken phase condition.
- d) Do not connect the grounding wire to the gas pipe or water pipe.
- e) Do not connect the electric leakage circuit breaker electric furnace to earth line with these device.



**Warning: The user must maintain the proper grounding of all system components.**

## 3. Operation and notice

### 3.1 Operation procedure

Please follow the requirements of

“2.Installation and notes”in this manual to plug-in the power phase number and position,install power well, after ensure the right condition of power installation can star up the machine.

- 1) Put the pretreatment workpiece on the hanger.
- 2) press the start switch, at this time, the power light is on,the fan motor is working.
- 3) Operator can start to do powder coating job.
- 4) After finishing the powder coating,operator can take out the workpiece directly and change the new one.
- 5) When emergency appeared in powder coating ,the power can be cut off directly,after troubleshooting can switch on the power again.

### 3.2 Change color

Color changing operating procedure:

1. Take off the filter cartridge and use the compressed air flow to clean the inside of spray booth.
2. Clean and blow out the whole spray booth.
3. Clean up the extra powder in the booth and wipe.
4. Take off filter cartridge,clean up the rest of powder in spray booth,use the duster cloth to wipe and clean.
5. Clean-up the whole spray booth thoroughly.(vacuum cleaner and duster cloth)
6. Connecting the new filter cartridge.
7. Finally,clean and check over the spray booth.
8. In the whole process of powder color changing,keep the ventilation.

### 3.3 Operation notice

- 1) First use of this machine,must check the filter cartridge and fan motor whether work properly.
- 2) Keep good ventilation in the operating area.

- 3) Make sure the machine is grounded well..
- 4) Do not operating with electric while maintenance,must cut of the general power ,and then allow to maintain.

#### 4.Daily maintenance and protection

Project	Contain	Time
Spray booth chamber	keep the booth clean	Any time
Filter	Keep ventilation gate clear	Any time
Fan motor	Keep grounding state	Any time

#### 5. Common troubleshooting



**Waring:Do not operating with electric while maintenance,must cut of the general power ,and then allow to repair.**

Troubles`	Reason analysis	Troubleshooting
Can not star up after connecting the power	2.1.Power does not meet the requirements of the specification 2.Maybe earth line is not connected	1.Connected the right specification power 2.Connected the earth line
Weak suction	Fan motor is getting old	Change fan motor
Powder escape from the exhaust gate	Filter cartridge damaged	Change filter cartridge